



- ⚠ WARNING:** Although the logic box includes a water resistant coating it is important to keep water out of the control and logic boxes. Prolonged exposure to water will cause damage.
- ⚠ WARNING:** When the cover of the control or logic box is removed check that the O-ring under the cover is intact and free of dirt and debris.
- ⚠ WARNING:** The Electric Gemini uses current limiting for both the monitor and nozzle stops. Use only appropriate Akron Brass nozzles.
- ⚠ WARNING:** Do not use the electric controls when the override cranks are being used or are in position for use.
- ⚠ WARNING:** Make the connection of the vehicle and auxiliary battery the final step.
- ⚠ WARNING:** If any tags or bands are worn or damaged and cannot be easily read, they should be replaced.
- ⚠ WARNING:** Disconnect power and disable flow before maintenance.
- ⚠ WARNING:** The Electric Gemini is not designed for auto oscillation.
- ⚠ WARNING:** Keep all personnel out of the Danger Zone (Figure 4), in front of the outlet of the monitor when the water source is attached. Dangerous flow velocities can cause serious injury.
- ⚠ WARNING:** The Electric Gemini monitor contains moving parts. Keep hand, finger and objects away from pinch points.
- ⚠ WARNING:** Not designed for explosive environments.
- ⚠ WARNING:** Exceeding the maximum pressure and flow of the monitor or nozzle may cause damage.



## GENERAL INSTRUCTIONS

- Review the instructions, wiring diagram, component layout and rotational stops diagram before installing this unit. This unit operates on 12 volt DC or 24 volt DC depending on the unit chosen. All electrical current flows through the wires. The monitor does not act as a ground. The wires from the control boxes can be cut to the length for the application plus 10 inches (See STEP 2). Do not extend the wires from the logic box to the monitor.

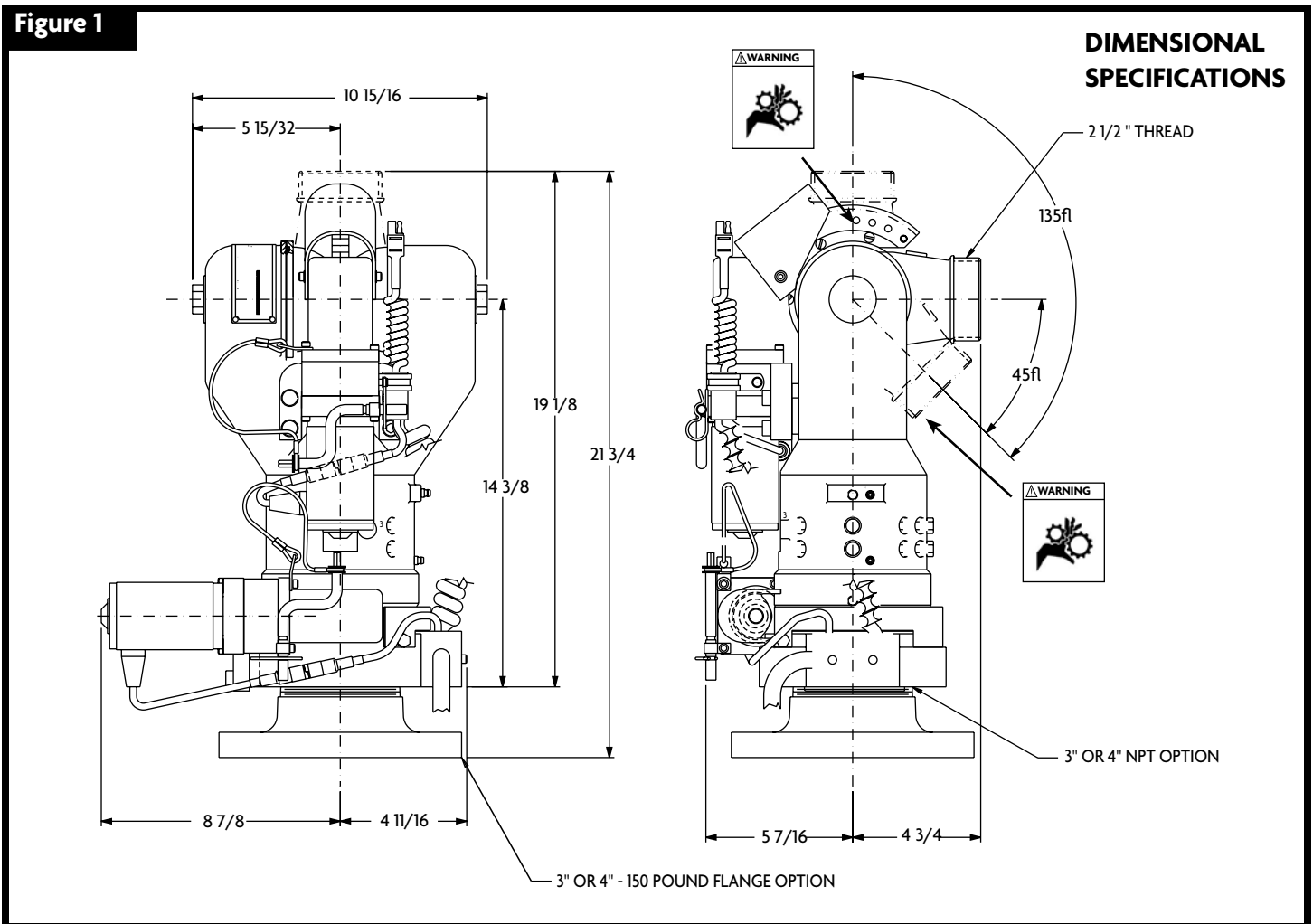

- The optional auxiliary battery is used for power failures and to ensure that the proper voltage and current are maintained at the logic box when using a smaller gauge wire for the vehicle battery wires. If the optional auxiliary battery is used, do not extend the auxiliary battery wires. This will ensure that the proper voltage and current are maintained at the monitor for it to operate properly. The optional battery is automatically recharged by the truck electrical system through the positive (auxiliary battery) and ground connections on the circuit board (Figure 2). The vehicle battery connections must have power turned on whenever the truck is running so that the battery can be recharged properly. If possible, connect the positive (vehicle battery) wire directly to the main vehicle battery or main master switch. A diode in the logic box will prevent the optional battery from feeding current back into the main truck system.
- Not recommended for use in salt water applications.
- For firefighting by trained firefighters only.
- For use with water or standard fire fighting foams only. After use with foam, flush with fresh water.
- Do not use the Electric Gemini nozzle as a forcible entry tool.
- Drain the Electric Gemini monitor and nozzle after use to prevent “freeze damage”.
- Ensure that the thread in the nozzle swivel matches the thread on the Electric Gemini outlet. Do not overtighten the nozzle onto the Electric Gemini.
- The Electric Gemini monitor, nozzle, logic box, control boxes, optional battery, and field adjustable rotation stops are made for optimal performance, Do not alter in any manner.
- Do not install shutoffs on the outlet of the Electric Gemini.
- Mount the logic box, control boxes and optional battery out of Danger Zone (Figure 4).

## ELECTRICAL INSTALLATION INSTRUCTIONS

These electrical instructions are for a Universal I logic box. Use style 6032 Universal II logic box installation and operating instructions for a UII logic box. (Sheet #122552)

### A. CONTROL BOXES AND JOYSTICKS WIRING AND ATTACHMENT

The Electric Gemini upper and lower controls use the same control box. The following steps will prepare either one or both control boxes and joystick for attachment to the logic box.

- STEP 1** If the control box includes an attached cable skip to STEP 5.
- STEP 2** Determine the length of #20-7 cable needed, add 10 inches, then cut. For example, if a five foot length of cable is needed, add 10 inches and cut the cable 5 foot 10 inches long.
- STEP 3** Remove the cable grip nut and washer from the control box and put it on the cable with the threads facing the box. On the same end of the cable remove 4 inches of the outer casing of the cable and strip back  $\frac{3}{8}$  inch from each of the 7 wires.
- STEP 4** Remove the four control box cover screws and set the control box cover aside. Thread the 7 wires through the cable grip attached to the control box and attach them to the proper terminals. Reattach control box cover and secure with the four screws. Tighten the cable grip nut and washer on the cable to the cable grip on the control box to secure the cable.
- STEP 5** Remove the cable grip nut from the plastic bag and put it on the other end of the cable with the threads facing out. Remove 6 inches of the outer cover and strip back  $\frac{3}{8}$  inch from each of the 7 wires.
- STEP 6** Remove the 6 logic box cover screws and set the logic box cover aside. Thread the 7 wires through the upper or lower control hole in the logic box (see component layout, Figure 3). Thread the cable grip washer and cable grip nut with the threads facing the box on the cable. Pull enough cable through the cable grip to ensure a good fit. Tighten the cable grip nut and attach the individual wires to the proper terminals (see wiring schematic Figure 2 & 2A). Reattach the logic box cover and secure with the 6 screws.

*NOTE: The lower control and upper control wires must be attached to the correct terminals for the lower control to override the upper control. None of the functions can be controlled from the upper control box when any of the switches on the lower control box are activated.*

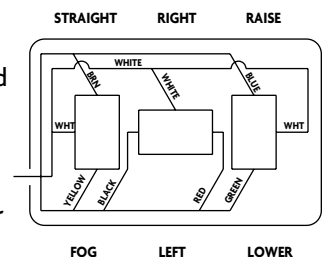

### B. MONITOR WIRING HARNESS ATTACHMENT

These instructions are to attach the monitor wiring harness to the logic box.

- STEP 7** Remove the cable grip nut from the logic box for the wiring harness cable. **DO NOT REMOVE THE CABLE GRIP.** Put the cable grip nut on the wiring harness (#16-6) cable with the threads facing out. Put the cable through the correct logic box cable grip (see component layout, Figure 3) so the cable grip nut will grab the outer cover of the cable. Tighten the cable grip nut and attach the individual wires to the proper terminals (see wiring schematic Figure 2).

### C. BATTERY ATTACHMENT

The battery connections should be the last connection made.

**STEP 8** AUXILIARY BATTERY - Remove the logic box cable grip nut for the auxiliary battery and place it on the battery (#16-3) cable with the threads facing out. Thread the cable through the cable grip nut until the cable grip will grab the cable. Tighten the cable grip and attach the individual wires to the proper terminals(see wiring schematic Figure 2).

NOTE: Auxiliary Battery is not intended to operate the monitor.

**STEP 9** VEHICLE BATTERY - Remove the logic box cable grip nut for the vehicle battery and thread on to the battery (#10-2 or #12-2 depending on length) cable with the threads facing out. Thread the cable through the cable grip until the cable grip nut will grab the cable. Tighten the cable grip nut and attach the individual wires to the proper terminals (see wiring schematic Figure 2). Reattach the logic box cover and secure with the 6 screws.

**NOTE: To supply enough current to operate the monitor properly, adequate wire size is critical.**

### D. MECHANICAL MONITOR ATTACHMENT

The Monitor is to be mounted on the waterway with  $\frac{5}{8}$  inch bolts and nuts of grade five minimum and suitable washers with a minimum of six threads engagement. The front of the monitor in Figure 4 is considered to be point 4 and is above the identification tag. The bolts must be tightened in a criss cross pattern progressively increasing tightening torque to a maximum of 100 pound feet dry.

NOTE: Not recommended to mount on a raised flange or have a butterfly valve between the flanges. This may cause damage to the monitor's flange when tightening the bolts.

THE ROTATIONAL AND ELEVATION STOPS SET THE BOUNDARIES FOR THE AREA IN WHICH THE MONITOR IS ALLOWED TO TRAVEL AND MEETS THE REQUIREMENTS OF THE NFPA. The upper row controls the right travel, and the lower row controls the left travel. The angles for the rotational stops are with respect to the "reference direction" illustrated in Figure 4. The monitor is shipped with the upper row stop at point 5 which stops the monitor at 90° right, clockwise and the lower row stop at point 3 which stops the monitor at 90° left, counterclockwise. All other positions are achieved by switching the factory set stop and the plug in the desired stop location. Both the stops and the plugs have a 1/2 inch hex head. Refer to Figure 4 to determine which stop location is needed for the desired right, clockwise or left, counterclockwise rotation. The elevation stop sets the upper limit of the elevation. The monitor is shipped with elevation stops at 45° above horizontal and 90° below horizontal to meet NFPA. All other vertical positions are achieved by moving the roll pin to the desired locations as indicated in Figure 5.

## OPERATING INSTRUCTIONS

### A. UPPER AND LOWER CONTROL OPERATION

The upper and lower control boxes are used to control the monitor and nozzle. To change the nozzle pattern toward the "straight stream" or "fog" position press the proper toggle switch toward "STRAIGHT" or "FOG" respectively. To change the horizontal monitor position toward the "RIGHT" or "LEFT" press the proper toggle switch toward "RIGHT" or "LEFT" respectively. To change the vertical monitor position upward or downward press the proper toggle switch toward "RAISE" or "LOWER" respectively.

THE LOWER CONTROL BOX FUNCTIONS WILL OVERRIDE THE UPPER CONTROL BOX FUNCTIONS IN COMPLIANCE WITH THE REQUIREMENTS OF THE NFPA STANDARD. NOTE: THE LOWER CONTROL AND UPPER CONTROL WIRES MUST BE ATTACHED TO THE CORRECT TERMINALS FOR THE LOWER CONTROL TO OVERRIDE THE UPPER CONTROL. NONE OF THE FUNCTIONS CAN BE CONTROLLED FROM THE UPPER CONTROL BOX WHEN ANY OF THE SWITCHES ON THE LOWER CONTROL BOX ARE ACTIVATED.

### B. MANUAL OVERRIDE CONTROLS

THE MANUAL OVERRIDE CONTROL IS TO BE USED WHEN THE POWER TO THE MONITOR IS OFF. Two override cranks are attached, one of the horizontal control and one for the vertical control. Both of them are  $\frac{1}{4}$  inch in size. A  $\frac{1}{4}$  inch Allen wrench will also actuate the overrides. To use the manual override pull the key pin which holds the override crank in place and insert the hex head end of the override crank in the hexagon shaped hole beside the crank storage bracket. Then rotate or spin the override crank either clockwise or counterclockwise to aim the monitor in the desired direction.

WHEN THE OVERRIDE CRANKS ARE NO LONGER IN USE PUT THEM BACK IN THE STORAGE POSITION. DO NOT USE THE ELECTRIC CONTROLS WHEN THE OVERRIDE CRANKS ARE BEING USED OR ARE IN POSITION FOR USE.

Figure 2

WIRING SCHEMATIC

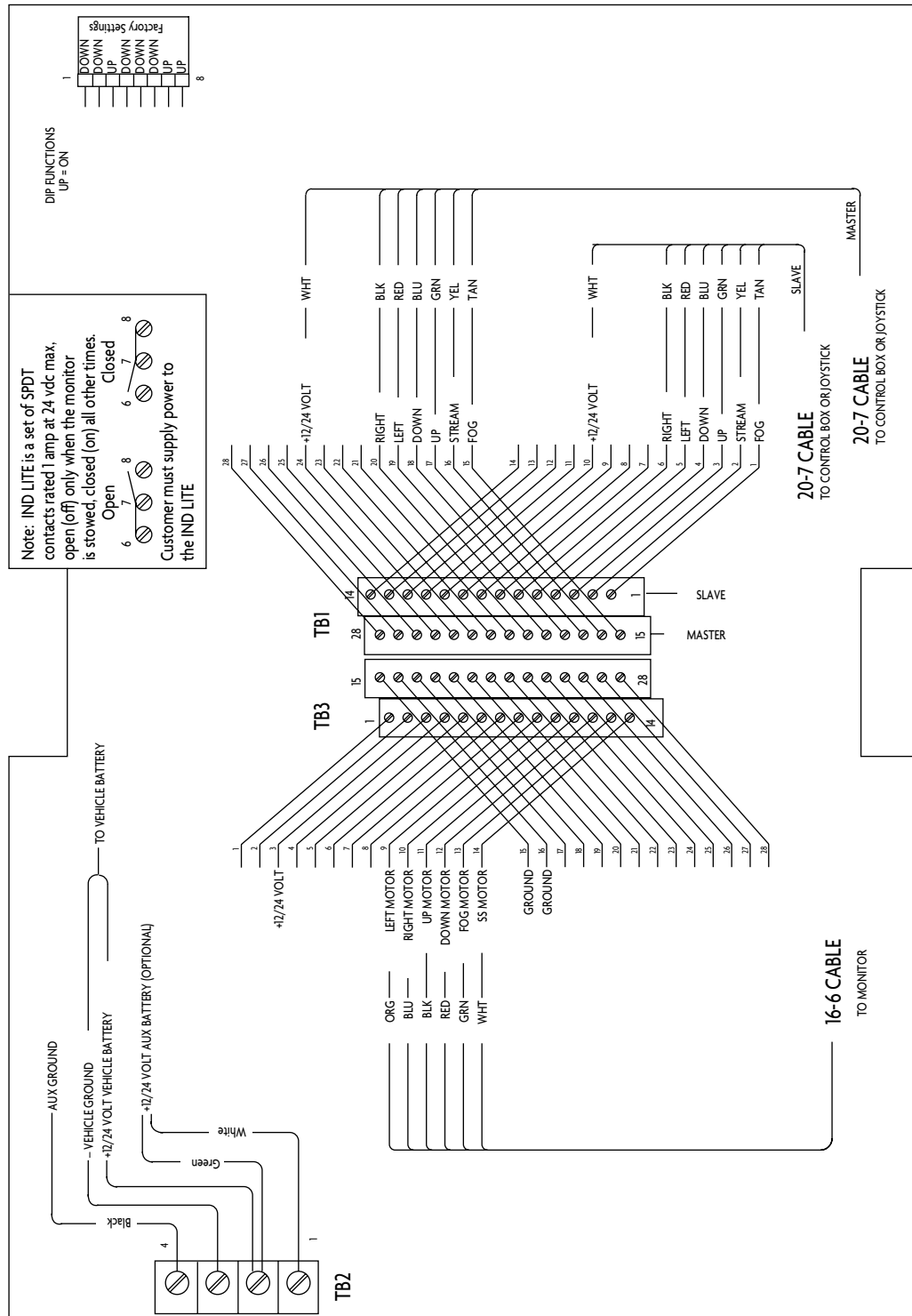
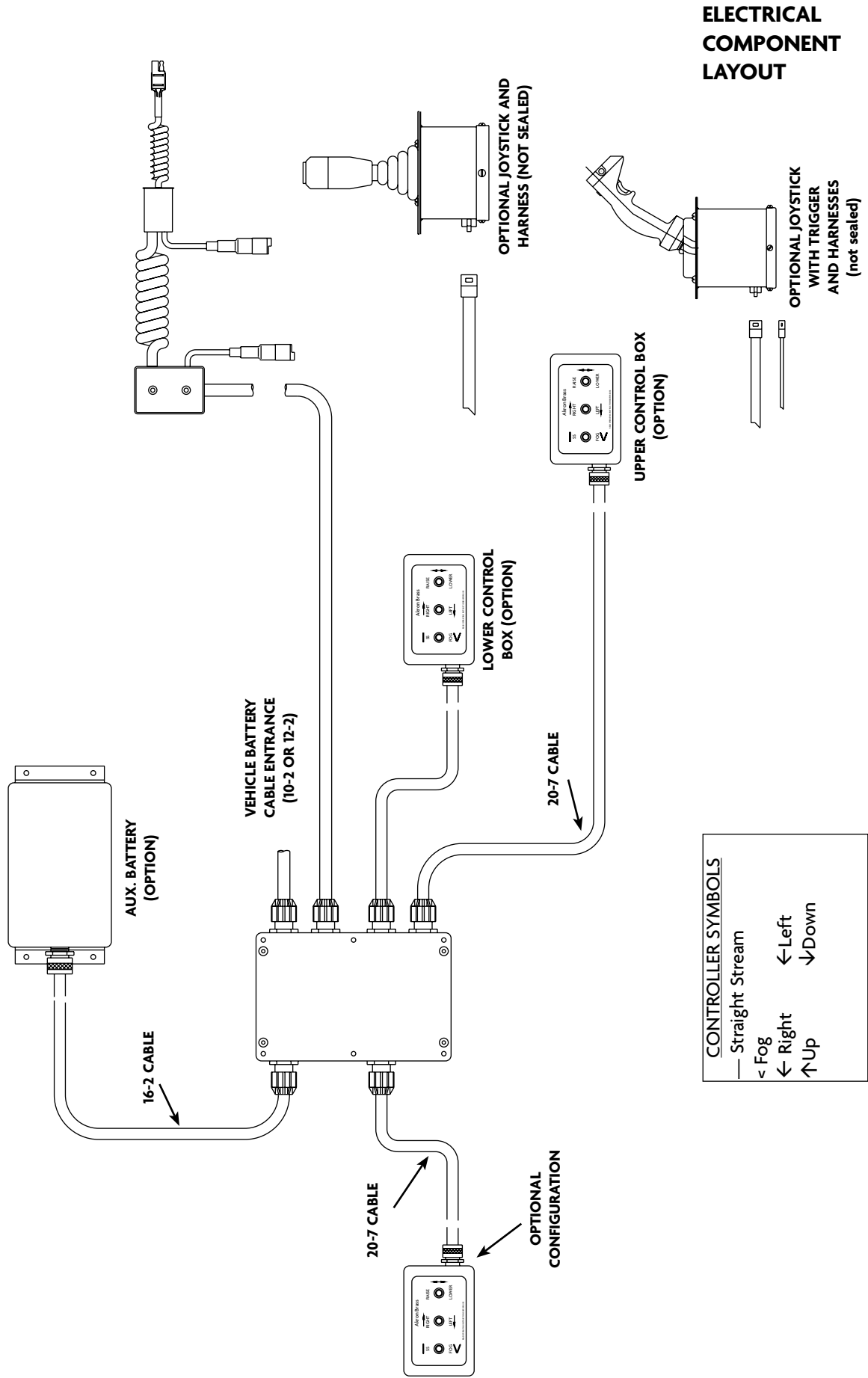
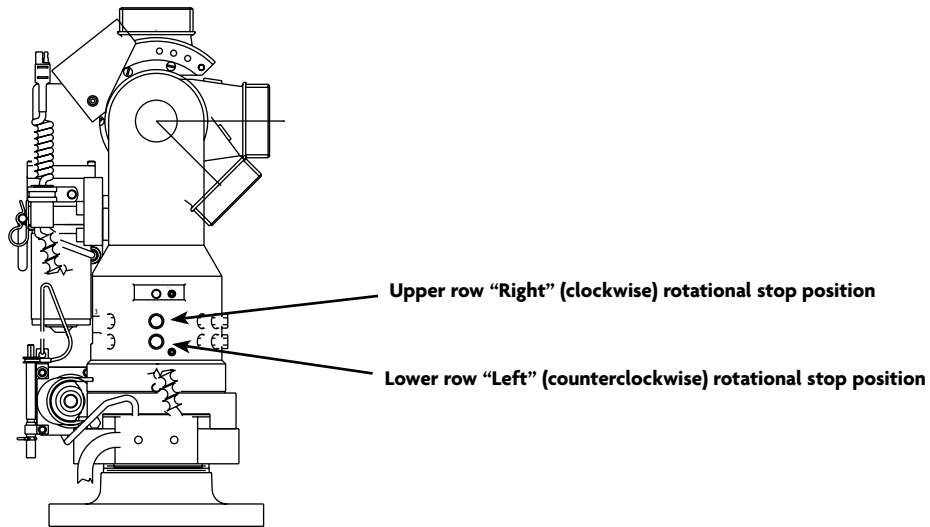
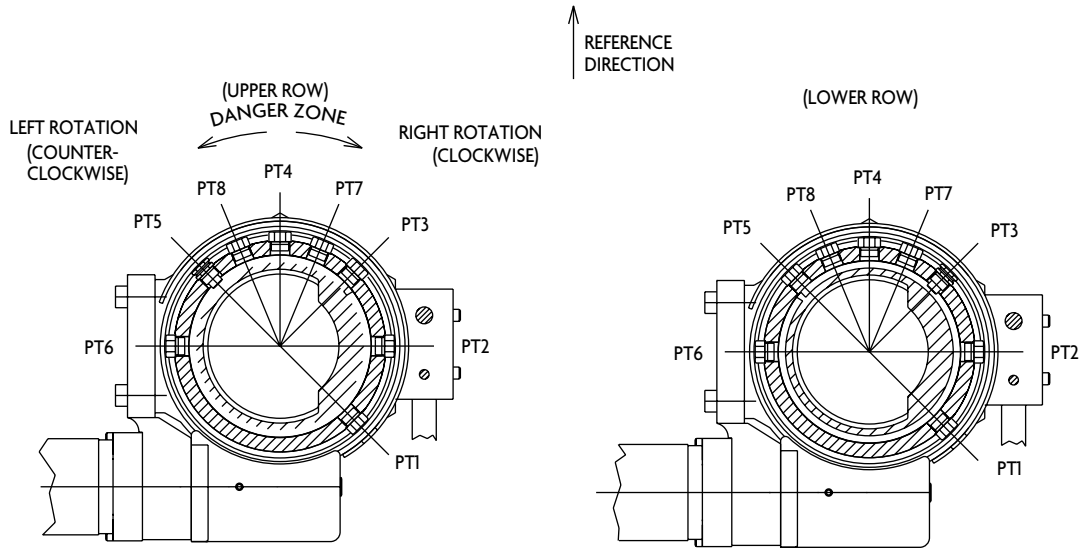

Figure 3



**Figure 4**



**ELECTRIC GEMINI  
ROTATION FOR EACH STOP COMBINATION**

**Lower Row**

Upper Row	CCW / CW	1	2	3	4	5	6	7	8	NO STOP
	1	78 / 168	78 / 213	78 / 258	45 / 270	0 / 270	78 / 33	67.5 / 270	22.5 / 270	78 / 270
	2	33 / 168	33 / 213	33 / 258	33 / 303	0 / 315	33 / 33	33 / 280.5	22.5 / 315	33 / 315
	3	180 / 0	135 / 0	90 / 0	45 / 0	0 / 0	315 / 0	67.5 / 0	22.5 / 0	348 / 0
	4	180 / 45	135 / 45	90 / 45	45 / 45	0 / 45	303 / 33	67.5 / 45	22.5 / 45	303 / 45
	5	180 / 90	135 / 90	90 / 90	45 / 90	0 / 90	258 / 33	67.5 / 90	22.5 / 90	258 / 90
	6	180 / 135	135 / 135	90 / 135	45 / 135	0 / 135	213 / 33	67.5 / 135	22.5 / 135	213 / 135
	7	180 / 22.5	135 / 22.5	90 / 22.5	45 / 22.5	0 / 22.5	315 / 22.5	67.5 / 22.5	22.5 / 22.5	325.5 / 22.5
	8	180 / 67.5	135 / 67.5	90 / 67.5	45 / 67.5	0 / 67.5	280.5 / 33	67.5 / 67.5	22.5 / 67.5	280.5 / 67.5
	NO STOP	180 / 168	135 / 213	90 / 258	45 / 303	0 / 348	315 / 33	67.5 / 280.5	22.5 / 325.5	N/A

**Factory Set Stops**

Each possible combination is listed and a maximum of 348 degrees can be achieved for total rotation. The factory will set the stops at Lower Row point 3 and Upper Row point 5. This will give a rotation of 90 degrees clockwise (CW) and 90 degrees counterclockwise (CCW) for a total rotation of 180 degrees.

**Figure 5**

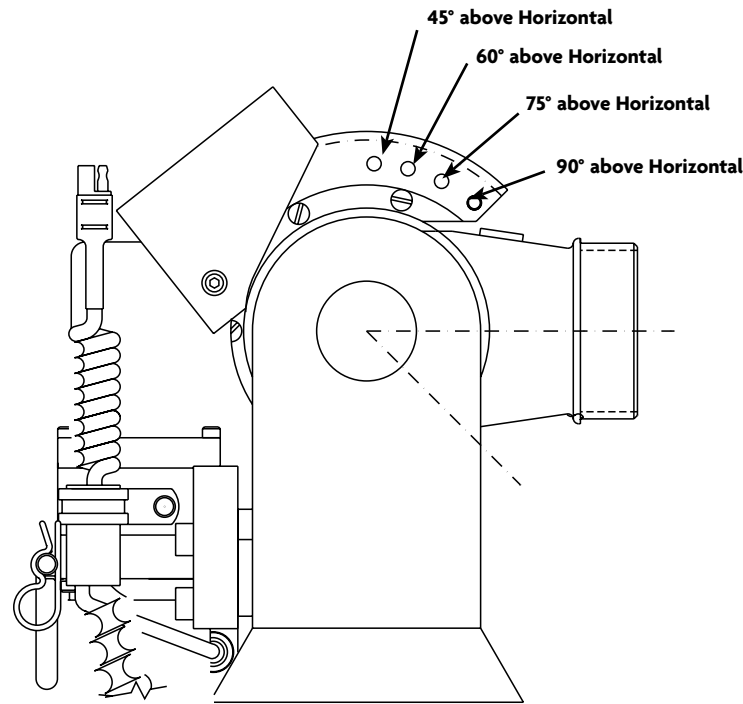

**ELEVATION  
STOPS**

**MAINTENANCE INSTRUCTIONS**

Your Electric Gemini monitor and nozzle should be inspected prior to and after each use, to ensure it is in good operating condition. Periodically, an unanticipated incident occurs where the Electric Gemini is misused in a manner that is inconsistent with standard operating practices and those listed in IFSTA. A partial list of potential misuse includes:

- Operating above maximum rated pressure and flow.
- Not draining, and allowing water to freeze inside.
- Prolonged exposure to temperatures above 130°F, or below -25°F.
- Operating in a corrosive environment.
- Having the Electric Gemini nozzle hit a fixed object during operating or transportation.
- Other misuse that might be unique to your specific environment.

Also there are many “tell tale” signs that indicate repair is in order, such as:

- Controls that are either inoperable or difficult to operate.
- Excessive wear.
- Poor discharge performance.
- Water leaks.

If any of the above situations are encountered, the Electric Gemini should be taken out of service, repaired, and tested by a qualified technician before placing it back in service.

**MOTOR REPLACEMENT**

To replace either the horizontal or vertical rotational motors:

1. Disconnect Power from the unit.
2. Loosen and remove the four socket screws (Item 54 on the Parts List) from the gearbox housing.
3. Slowly remove the motor assembly (25) and gearbox housing (6) from the unit.

**IMPORTANT: Make sure the internal gear, (Item 20 on the Parts List), remains in place, (hold with a screwdriver), to avoid gear alignment problems.**



4. Loosen and remove the four socket head capscrews (48) from the inside of the gearbox housing that hold the housing and the motor assembly together.
5. Remove gearbox housing (6) from the motor assembly (25).
6. Replace both o-ring seals (27 & 21) on the gearbox housing (6).
7. Attach the new motor assembly (25) to the gearbox housing (6) making sure all four screws (48) are tight.
8. Install the motor and gearbox housing assembly to the unit making sure all four socket screws (54) are tight. It may be necessary to rotate the motor slightly to get the motor gear to line up with the gears inside the gearbox.
9. Restore power to the unit.
10. Test the operation of the unit.

Call Akron Brass Customer Service Department if any problems are encountered.



PHONE: 330.264.5678 or 800.228.1161 | FAX: 330.264.2944 or 800.531.7335 | [akronbrass.com](http://akronbrass.com)

REVISED: 9/16

WARRANTY AND DISCLAIMER: We warrant Akron Brass products for a period of five (5) years after purchase against defects in materials or workmanship. Akron Brass will repair or replace product which fails to satisfy this warranty. Repair or replacement shall be at the discretion of Akron Brass. Products must be promptly returned to Akron Brass for warranty service.

We will not be responsible for: wear and tear; any improper installation, use, maintenance or storage; negligence of the owner or user; repair or modification after delivery; damage; failure to follow our instructions or recommendations; or anything else beyond our control. WE MAKE NO WARRANTIES, EXPRESS OR IMPLIED, OTHER THAN THOSE INCLUDED IN THIS WARRANTY STATEMENT, AND WE DISCLAIM ANY IMPLIED WARRANTY OF MERCHANTABILITY OR FITNESS FOR ANY PARTICULAR PURPOSE. Further, we will not be responsible for any consequential, incidental or indirect damages (including, but not limited to, any loss of profits) from any cause whatsoever. No person has authority to change this warranty.

© Akron Brass Company. 2011 All rights reserved. No portion of this can be reproduced without the express written consent of Akron Brass Company.