



CONTENTS

Scope of This Manual	5
Unpacking and Inspection	5
Safety	5
Terminology and Symbols	5
Quick-Start Operating Overview	6
Transducer Location	6
Pipe Preparation and Transducer Mounting	6
Transducer Connections	7
Startup	7
Introduction	8
General	8
Application Versatility	8
User Safety	9
Data Integrity	9
Product Identification	9
Transducer Installation	10
Unpacking and Inspection	10
Mounting Locations	10
Pipe Preparation	12
DT9 Clamp-On Transducer Mounting	12
DP7 Probe Transducer Mounting	13
Transmitter Installation	18
Unpacking and Inspection	18
Mounting Location	18
Dimensions	19
Transducer Wiring Connections	20
Power Supply Wiring Connections	21
AC Power Supply Connections	22
DC Power Supply Connections	22
Multiple Meter Installations	23
ISO Modules	24
4...20 mA Output Module	25
Internal Power Configuration	25
External Power Configuration	26

Control Relay Output Module	27
Rate Pulse Output Module	28
Instrument Programming	29
General	29
Keypad Operation	29
Totalizer Reset.	29
Menu Structure.	30
Hierarchy.	30
Menu Maps	31
Parameters	33
Setup Parameters	33
Module Configuration Parameters.	35
Advanced Configuration Parameters	36
Startup and Troubleshooting	38
Startup	38
Troubleshooting	39
Specifications.	40
North American Pipe Schedules	41
Part Number Construction.	46

SCOPE OF THIS MANUAL

This manual is divided into two main sections:

- “Quick-Start Operating Overview” on page 6 is intended to help you get the DFX flow meter up and running quickly. Refer to the detailed instructions if you require additional information.
- The remaining chapters provide a detailed description of all software settings and hardware installation guidance.

IMPORTANT

Read this manual carefully before attempting any installation or operation. Keep the manual accessible for future reference.

UNPACKING AND INSPECTION

Upon opening the shipping container, visually inspect the product and applicable accessories for any physical damage such as scratches, loose or broken parts, or any other sign of damage that may have occurred during shipment.

NOTE: If damage is found, request an inspection by the carrier’s agent within 48 hours of delivery and file a claim with the carrier. A claim for equipment damage in transit is the sole responsibility of the purchaser.

SAFETY

Terminology and Symbols



Indicates a hazardous situation, which, if not avoided, is estimated to be capable of causing death or serious personal injury.



Indicates a hazardous situation, which, if not avoided, could result in severe personal injury or death.



Indicates a hazardous situation, which, if not avoided, is estimated to be capable of causing minor or moderate personal injury or damage to property.

QUICK-START OPERATING OVERVIEW

This manual contains detailed operating instructions for all aspects of the DFX flow instrument. The following condensed instructions are provided to help you get the instrument up and running as quickly as possible. This pertains to basic operation of the clamp-on transducer only. If specific instrument features, a hazardous area installation or an alternate transducer style are to be used—or if you are unfamiliar with this type of instrument—see the appropriate section in the manual for complete details.

Transducer Location

Determine the appropriate mounting location for the transducers. (See *Figure 1.*) Pipe must be filled with liquid for proper operation.

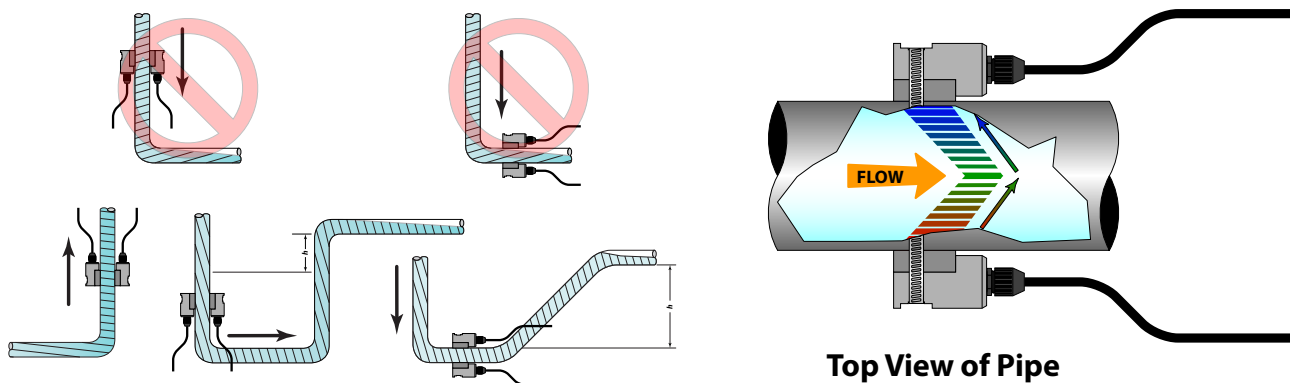

Figure 1: Transducer locations

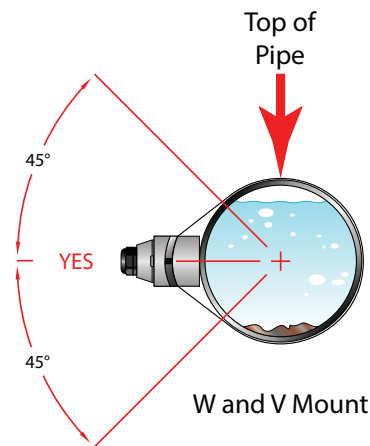

Figure 2: Transducer mounting configuration

Pipe Preparation and Transducer Mounting

1. The piping surface, where the transducers mount, needs to be clean and dry. Remove loose scale, rust and paint for satisfactory acoustical bonds.
2. Connect the mounting straps around the pipe. Leave the strap loose enough to slip the transducers underneath.
3. Apply a liberal amount of couplant grease onto the transducer faces.
4. Place each transducer under the mounting strap, 180° apart on the pipe. Verify that the transducer cables are facing the same direction on the downstream side of the flow. See *Figure 3.*
5. Route the transducer cable back to the monitor, avoiding conduits that contain high voltage AC supply wires.

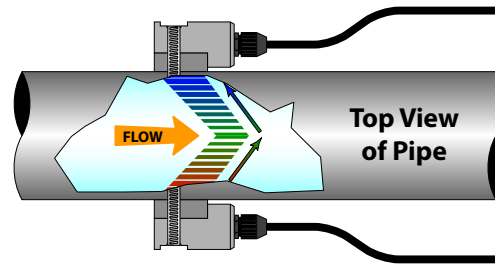

Figure 3: Transducer direction

Transducer Connections

1. Mount the monitor within the length of the transducer cables.
2. Route the transducer cables through the center conduit hole in the bottom of the enclosure and connect to terminal block J4. The terminal blocks are a removable and can be disconnected to simplify wiring access. See the wiring diagram inside the door for reference.

Startup

Initial Settings and Powerup

1. Verify that the power supply jumper settings are properly configured for the power supply. See “Power Supply Wiring Connections” on page 21 or the wiring and jumper selection diagram is located inside the door.

NOTE: Power supply selection is specified during order placement and appropriate jumpers are placed at the factory. If power is changed from AC to DC or vice versa, the fuse requirement changes. Fuse ratings are listed on the transmitter’s door.

2. Route power connections through the conduit hole farthest to the left and in the enclosure. Then connect power to the J2 terminal block. See Figure 11 on page 17.
3. Apply power. On initial power-up, the DFX flow meter conducts a series of self-diagnostic tests and buffering operations that take approximately 30 seconds.
4. Enter pipe internal diameter (Pipe ID), measuring units and output configuration.

INTRODUCTION

General

The DFX ultrasonic flow meter is designed to measure volumetric flow of solids-bearing or aerated liquid within a closed conduit. Transducers are available as non-contacting (DT9) or insertion probe (DP7) types. DT9 non-contacting transducers are strapped to the outside of a pipe and are suitable for most installations where the pipe material supports the transmission of ultrasound. Some pipe materials, such as concrete pressure pipe and some plastic lined pipes do not allow ultrasound to penetrate to the liquid inside. For these applications, use the DP7 insertion probe.

The flow meter operates by transmitting an ultrasonic sound from a transmitting transducer through the pipe wall or from the probe tip into the moving liquid. The sound is reflected by sonic reflectors suspended in the liquid and recorded by the receiving transducer. If the sonic reflectors are moving within the sound transmission path, sound waves are reflected at a frequency shifted (Doppler frequency) from the transmitted frequency. The shift in frequency is directly related to the speed of the moving particle or bubble. This shift in frequency is interpreted by the instrument and converted to various user defined measuring units.

The criteria for a good Doppler reflector are:

- The scattering material must have a sonic impedance (sound speed difference) at least 10% different from the fluid.
- There must be some particles large enough to cause longitudinal reflection—particles larger than 35 micron.
- For a given pipe size, the longitudinal reflection must have sufficient energy to overcome the Rayleigh (energy wasting) scattering caused by smaller particles.
- The reflecting material must travel at the same velocity as the fluid for good accuracy.

Application Versatility

The DFX flow meter can be successfully applied on a wide range of metering applications. The easy-to-program transmitter allows the standard product to be used on pipe sizes ranging from 1...120 in. (25...3050 mm) pipe ID. With the small pipe transducer option, the pipe size range is 0.25...1 in. (6...25 mm). A variety of liquid applications can be accommodated:

- Sewage
- River water
- Plant effluent
- Mining slurries
- Sludge
- Others

Because the transducers are non-contacting and have no moving parts, the flow meter is not affected by system pressure, fouling or wear. Standard transducers are rated to a pipe surface temperature of 250° F (121° C).

User Safety

The DFX flow meter employs modular construction and provides electrical safety for the operator. The enclosure is constructed from rugged polycarbonate plastic with UV inhibitors. The enclosure does not contain any conductive materials that can become energized while the door is closed. The keypad is made of polycarbonate and is designed for outdoor use. The AC power transformer provides 4000 Volts of isolation from the power supply mains. The display face contains voltages no greater than 24V DC. Output modules are optically isolated from external power supplies and provide a great degree of immunity to ground loops.

CAUTION

IF THE DFX FLOW METER IS USED IN A MANNER NOT SPECIFIED BY THE MANUFACTURER, THE PROTECTION PROVIDED BY THE EQUIPMENT MAY BE IMPAIRED.

Data Integrity

The DFX flow meter retains all user configuration data and totalizer accumulations in non-volatile FLASH memory indefinitely.

Product Identification

The serial number and complete model number of the transmitter are on the side of the monitor enclosure.





<p>Badger Meter, Inc. Assembled in USA</p> <p>Model: S/N: Mfg Date: Rating: 12-28V DC === 7W Scale Factor: Pipe Size: Output: 4mA: 20mA:</p> <p>CAUTION: Equipment must be isolated or disconnected from hazardous line voltage before opening enclosure. ATTENTION: Équipement doit être isolé ou déconnecté de la tension d'alimentation dangereux avant d'ouvrir la pièce jointe.</p> 	<p>Badger Meter, Inc. Assembled in USA</p> <p>Model: S/N: Mfg Date: Rating: 115V AC~50/60 Hz @ 17VA Scale Factor: Pipe Size: Output: 4mA: 20mA:</p> <p>CAUTION: Equipment must be isolated or disconnected from hazardous line voltage before opening enclosure. ATTENTION: Équipement doit être isolé ou déconnecté de la tension d'alimentation dangereux avant d'ouvrir la pièce jointe.</p> 	<p>Badger Meter, Inc. Assembled in USA</p> <p>Model: S/N: Mfg Date: Rating: 230V AC~50/60 Hz @ 17VA Scale Factor: Pipe Size: Output: 4mA: 20mA:</p> <p>CAUTION: Equipment must be isolated or disconnected from hazardous line voltage before opening enclosure. ATTENTION: Équipement doit être isolé ou déconnecté de la tension d'alimentation dangereux avant d'ouvrir la pièce jointe.</p> 	<p>Badger Meter, Inc. Assembled in USA</p> <p>Model: S/N: Mfg Date: Rating: 100V AC~50/60 Hz @ 17VA Scale Factor: Pipe Size: Output: 4mA: 20mA:</p> <p>CAUTION: Equipment must be isolated or disconnected from hazardous line voltage before opening enclosure. ATTENTION: Équipement doit être isolé ou déconnecté de la tension d'alimentation dangereux avant d'ouvrir la pièce jointe.</p> 
-----------------------------------------------------------------------------------------------------------------------------------------------------------------------------------------------------------------------------------------------------------------------------------------------------------------------------------------------------------------------------------------------------------------------------------------------------------------------------------------------------------------------------------------------------------------------------------------------------------	------------------------------------------------------------------------------------------------------------------------------------------------------------------------------------------------------------------------------------------------------------------------------------------------------------------------------------------------------------------------------------------------------------------------------------------------------------------------------------------------------------------------------------------------------------------------------------------------------------------	-------------------------------------------------------------------------------------------------------------------------------------------------------------------------------------------------------------------------------------------------------------------------------------------------------------------------------------------------------------------------------------------------------------------------------------------------------------------------------------------------------------------------------------------------------------------------------------------------------------------	--------------------------------------------------------------------------------------------------------------------------------------------------------------------------------------------------------------------------------------------------------------------------------------------------------------------------------------------------------------------------------------------------------------------------------------------------------------------------------------------------------------------------------------------------------------------------------------------------------------------

Figure 4: Product labels

TRANSDUCER INSTALLATION

Unpacking and Inspection

Upon opening the shipping container, visually inspect the product and applicable accessories for any physical damage such as scratches, loose or broken parts, or any other sign of damage that may have occurred during shipment.

NOTE: If damage is found, request an inspection by the carrier’s agent within 48 hours of delivery and file a claim with the carrier. A claim for equipment damage in transit is the sole responsibility of the purchaser.

Mounting Locations

The transducers contain piezoelectric crystals for transmitting and receiving ultrasonic sound energy through the pipe wall (DT9) and from the probe tip (DP7). Placement of the ultrasonic transducer is the most critical step in achieving an accurate and reliable flow reading. All flow meters of this type rely on a full-pipe of fluid that is flowing symmetrically (evenly) in the pipe. Flow in partially filled pipes and immediately downstream of elbows, valves and pumps is unstable and leads to unstable readings and non-linearity.

The DFX flow meter has software algorithms that assume a full pipe of liquid. Install only in locations where the pipe is filled at all times when flow measurements are required. Avoid partially filled pipes that can lead to very large flow measurement errors. See *Figure 5* for possible pipe configurations.

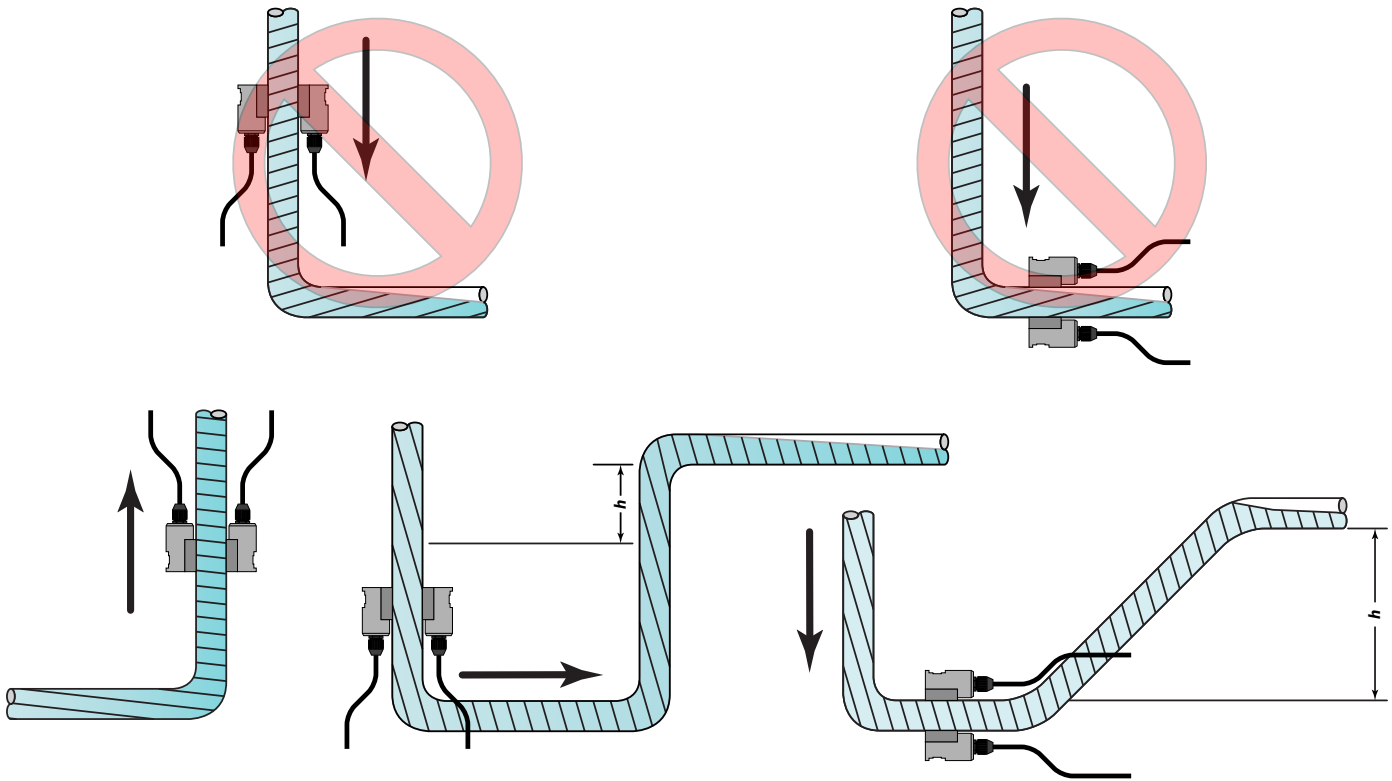

Figure 5: Pipe configurations and installation recommendations

Select a transducer mounting location with adequate straight runs of pipe, both upstream and downstream, to achieve stable readings¹. See *Figure 6* for examples of minimum upstream and downstream requirements.

Piping Configuration and Transducer Positioning	Upstream Pipe Diameters	Downstream Pipe Diameters
	*	**
	14	5
	10	5
	10	5
	10	5
	24	5

Figure 6: Upstream/Downstream Pipe Requirements

¹ The DFX system provides repeatable measurements on piping systems that do not meet these requirements, but the accuracy may be affected.

Pipe Preparation

Before the transducer heads are mounted to the pipe surface, an area slightly larger than the flat surface of the transducer face must be prepared. If pipe insulation is present, it must be peeled back to expose the pipe surface. Use a wire brush to remove loose paint, rust, scale or dirt. Paint, if bonded well to the pipe surface, does not need to be removed. Any bumps present on ductile iron pipe do not need to be removed. Thoroughly dry the mounting surfaces so that the couplant grease bonds to the surface.

NOTE: Small pits in the piping surface typically do not significantly impact ultrasonic transmission or signal reception.

Couplant

Use a coupling compound to create an acoustically conductive path between the transducer and the prepared pipe surface. Clamp-on ultrasonic meters do not operate without coupling compound mounted between the pipe wall and the transducer face. Enclosed with the DFX system is a tube of coupling compound that is adequate for general purpose applications. Use a silicone-based valve grease or RTV (Room Temperature Vulcanizing) products or grease for Doppler installations as they operate over a very wide temperature range. In some installations, such as automotive, silicone is not permitted. Alternate petroleum-based products can be used, but verify that the grease is rated not to flow at the maximum surface temperature anticipated on the pipe.

In general, use the following couplants with these transducers:

Transducer	Couplant
DT90, DT91, DT94, DT95	Dow 732 or Dow 111 (or equivalent)
DT92, DT93, DT96, DT97	Krytox® LVP
DP7	Not applicable

Table 1: Transducer couplants

DT9 Clamp-On Transducer Mounting

Clamp-on transducers should be mounted on the pipe 180° apart and facing each other on the pipe, with the cables on the downstream side of the transducers. If the pipe is horizontal, the preferred mounting orientation is 3 and 9 o'clock, with 12 o'clock being the top of the pipe. See *Figure 7*. Orientation on vertical pipes does not matter.

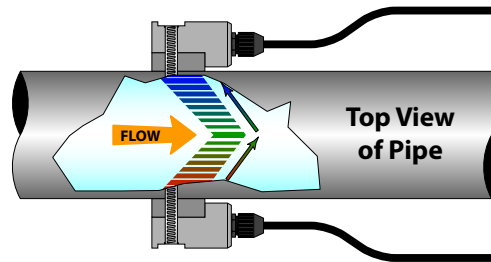

Figure 7: Transducer Placement

Large pipe installations use stainless steel straps to secure the transducers to the outside of the pipe. The DFX system is shipped with four 36 in. (900 mm) straps, which are suitable for pipes up to 39 in. (1000 mm) diameter.

1. Select the proper number of transducer straps to allow a complete strap to go around the circumference of the pipe. If a pipe is larger than 39 in. (1000 mm), use a single strap/buckle arrangement to reduce the number of strap connections. The straps can be connected together to make a continuous length. Small pipe installations use an integral clamping mechanism built into the transducer.

Pipe Size	Straps Required
1...9 in. (25...225 mm)	1
10...19 in. (250...480 mm)	2
20...29 in. (500...740 mm)	3
30...39 in. (760...1000 mm)	4

Table 2: Straps required vs. pipe size

2. Wrap the strap around the pipe where the transducers mount. Leave the strap loose enough to allow the transducers to be placed underneath. If multiple straps are being used, wrap electrical tape around all but one strap connection to secure the strap worm screws in place.
3. Spread an even layer of coupling compound, approximately 1/8 in. (3 mm) thick, to the prepared transducer mounting areas of the pipe.
4. Spread an even layer of coupling compound, approximately 1/8 in. (3 mm) thick, to the flat face of the two transducers.
5. Place each transducer under the strap with the flat face—amber plastic window—positioned towards the pipe. The notch on the back of the transducer provides a mounting surface for the strap. The transducer cables must be facing in the same direction and downstream of the transducers for proper operation.

NOTE: Large pipes may require two people for this procedure.

6. Tighten the strap enough to hold the transducers in place, but not so tight that all of the couplant squeezes out of the gap between the transducer face and pipe. Make sure that the transducers are squarely aligned on the pipe and 180° apart. If RTV is used, avoid moving the transducers during the curing time (typically 24 hours) as bubbles may form between the transducer and pipe that can reduce ultrasonic signal transmission to unsatisfactory levels.
7. Route the transducer cables back to the area where the transmitter mounts, avoiding high voltage cable trays and conduits. While transducer cable extension is not generally recommended, if additional transducer cable length is required, use cable and connectors of the correct type and impedance. In many cases, especially if a splice may be exposed to water or other liquids, it may be more effective to replace the entire cable. Transducers use RG59, 75 Ohm coaxial cable or Twinax (Belden #9463) or (Belden # 9463DB) 78 Ohm two conductor cable.
8. If the transducers are permanently mounted using Dow 732, the RTV must be completely cured before proceeding to Instrument Startup. Make sure that no relative motion between the transducer and pipe occurs during the 24 hour curing process. If Dow 111 grease was used for temporary operation of the DFX system, proceed with the Startup procedures.

DP7 Probe Transducer Mounting

The DP7 insertion transducer that is used by the DFX flow meter contains piezoelectric crystals for transmitting and receiving ultrasonic sound energy. The black Ultem® plastic tip of the DP7 transducer contains these crystals, which are designed to be inserted just into the path of the flowing liquid.

Select a transducer mounting location that is completely filled with liquid when flow measurements are made (see *Figure 5*) and with adequate straight runs (without disturbances) of pipe, both upstream and downstream, to achieve stable and accurate readings. Examples of minimum upstream and downstream requirements are included in *Figure 5 on page 10*.

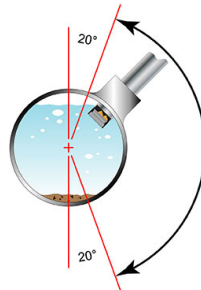

Figure 8: Installation locations

When installing the DP7 transducer in a horizontal pipe, the preferred orientation is at least 20 degrees from the top or bottom of the pipe. Verify that the mounting location allows for adequate clearance to install and retract the probe fully from the pipe.

The following instructions cover hot tapping applications where the installation or removal of the transducer probe must be done without shutting down the process pressure. If the product is being installed without an isolation valve, ignore the steps that pertain to its installation. *Figure 9* illustrates an exploded view of an isolation valve assembly and names the various components.

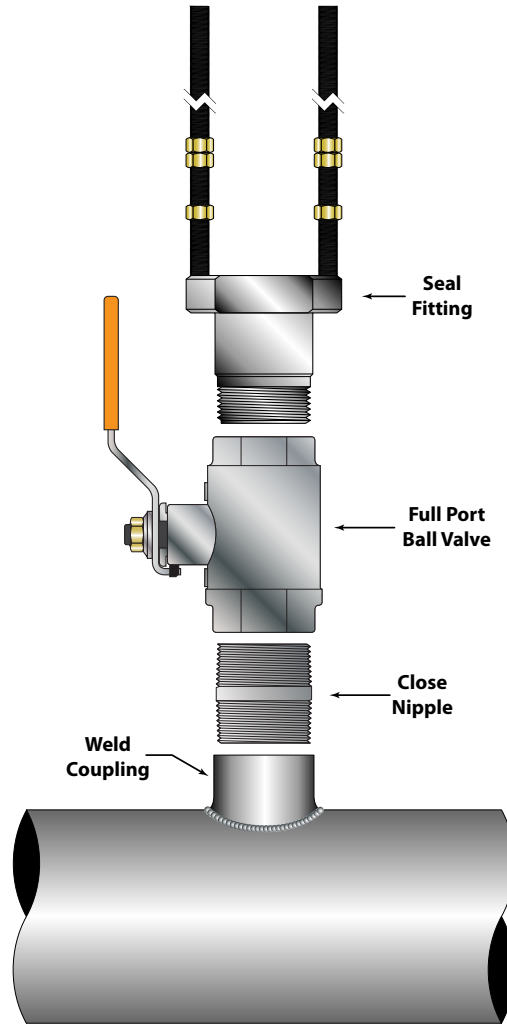

Figure 9: Hot tap installation

The Bronze Hot Tap Kit (p.n. D030-1006-001) and the Stainless Steel Hot Tap Kit (p.n. D030-1006-002) include an isolation valve assembly and are designed for installation in pipes under pressure, up to 700 psi (48 bar) at 70° F (21° C).

All items required for installation are provided with the kit, except for the 1-1/2 in. NPT weld coupling or service saddle and the drilling and welding equipment. These instructions call for the use of a drilling machine designed for operations under pressure (for example, Mueller Co., Water Products Division).

1. Verify that the pipe's line pressure is within the rated limits of the pressure drilling machine being used.
2. Grind off paint or other coatings from the pipe in the DP7 probe mounting area.
3. Tack weld a 1-1/2 in. NPT weld coupling to the pipe or install a service saddle according to the supplier's instructions. The coupling or saddle must be aligned perpendicular to the pipe axis and square to its plane.
4. Complete welding. A water tight, 0.25 in. minimum weld bead is recommended.
5. Install the close nipple (supplied with assembly) into the weld coupling. Use appropriate pipe sealants.
6. Install the isolating ball valve on the close nipple. Verify that the valve is in the fully open position.
7. Install drill bit and adapter into the pressure drilling machine. Then attach the machine to the isolation valve.
8. Drill through the pipe wall in accordance with the instructions supplied with the drilling machine.
9. Withdraw the drill bit through the isolating valve.
10. Close the valve and remove the drilling machine.
11. Check for leakage at valve and connections.
12. Place pipe sealant on the 1-1/2 in. NPT threads of the insertion fitting assembly.
13. Screw the assembly into the isolation valve and tighten with a 2-1/2 in. pump wrench.

Probe Cables

Before inserting the probe into the pipe, the sensor cables should be routed to the transmitter location. Verify that the supplied cable length is sufficient to meet the installation requirements. While transducer cable extension is not generally recommended, if additional transducer cable length is required, use cable and connectors of the correct type and impedance. In many cases, especially if a splice may be exposed to water or other liquids, it may be more effective to replace the entire cable. Transducers use RG59, 75 Ohm coaxial cable, Twinax (Belden #9463) or (Belden # 9463DB) 78 Ohm two-conductor cable.

⚠ CAUTION

THE PROBE CABLES ARE DESIGNED TO CARRY LOW LEVEL SIGNALS THAT ARE DEVELOPED BY THE SENSOR. CARE SHOULD BE TAKEN IN ROUTING THE CABLES. AVOID RUNNING CABLES NEAR SOURCES OF HIGH VOLTAGE OR EMI/RFI. ALSO AVOID ROUTING THE CABLES IN CABLE TRAY CONFIGURATIONS, UNLESS THE TRAYS ARE SPECIFICALLY USED FOR OTHER LOW VOLTAGE, LOW LEVEL SIGNAL CABLES.

⚠ CAUTION

THE INTERNAL DP7 PROBE WIRING IS EPOXY ENCAPSULATED TO SEAL IT FROM MOISTURE. THE DP7 PROBE IS PROVIDED WITH TWO COAXIAL CABLES TO SHIELD THE LOW LEVEL SIGNALS AND MUST BE CONTINUOUS TO THE DP7 PROBE TRANSMITTER. EXCESS WIRE MAY BE CUTOFF OR SIMPLY COILED NEAR THE DFX FLOW METER.

Probe Retraction Procedure

1. Retract the probe by loosening the upper jam nuts counterclockwise as viewed from the top of the probe using the proper size wrench. If the pipe is under pressure, the nuts must be turned alternately about two turns at a time to prevent binding as a result of non-equal seal loading. In many cases, the line pressure causes the probe to retract. Should the probe bind, use the retraction nuts on the lower side of the probe flange to assist in the probe retraction. Continue this procedure until the probe is fully retracted into the isolation valve.

⚠ CAUTION

DO NOT RUN THE DRIVE NUTS OFF THE RODS UNTIL THE ISOLATION VALVE IS FULLY CLOSED.

2. After the probe is retracted past the "ball" in the isolation valve, the isolation valve may be closed to isolate the probe from the line so the probe can be removed entirely.

⚠ CAUTION

IF THE INSERTION PROBE IS NOT ABOVE THE "BALL" OF THE ISOLATION VALVE, THE VALVE CANNOT BE CLOSED. IF THE VALVE WILL NOT CLOSE SMOOTHLY, THE BODY OR TIP OF THE PROBE IS MOST LIKELY NOT ABOVE THE "BALL". ATTEMPTING TO FORCE THE VALVE INTO THE CLOSED POSITION MAY RESULT IN DAMAGE TO THE PROBE.

Probe Insertion

Before inserting the DP7 probe into the piping system, calculate the probe insertion depth. Refer to the paragraphs that follow and *Figure 10 on page 17* for information regarding this process. The variables required are:

- The overall probe length
- Pipe internal diameter (ID)
- Pipe wall thickness
- The length of the valve stack
- Amount of straight pipe diameters in the system

To Calculate Insertion Depth

Using this information and referring to *Figure 10*, proper insertion depth can be determined.

- Measurement A — The typical depth that the DP7 probe tip is inserted into the piping system is 1/8 (12.5%) of the pipe internal diameter.
- Measurement B — Pipe wall thickness. This information can be obtained from standard pipe wall charts (see “Specifications” on page 40) or ideally can be measured using an ultrasonic wall thickness gauge.
- Measurement C — Measure the distance that is going to be taken up by the pipe tap, nipple, full-flow ball valve and the insertion fitting. DP7 probes use 1-1/2 in. NPT hardware and the insertion fitting is approximately 2-1/2 in. in height.
- Measurement D — The length of DP7 probe that protrudes from the insertion fitting after it is inserted to the proper depth in the fluid stream.
- Measurement E — This is the overall length of the probe measured from the black measurement tip to the top flange on the probe.

Measure and record the following linear dimensions.

A	=	0.125 x Pipe OD	=	_____
B	=	Pipe Wall Thickness	=	_____
C	=	Seal Fitting to Pipe Wall	=	_____
D	=	E - C - B - A	=	_____
D	=	_____	=	_____
E	=	Probe Length	=	_____

NOTE: For some low pressure/low temperature applications less than 30 psi (2.1 bar) and less than 100° F (38° C), the probe may be pushed in by hand to decrease the insertion time.

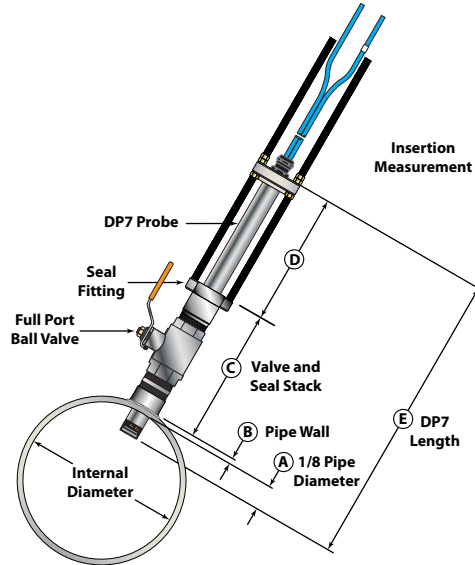

Figure 10: Installation measurements

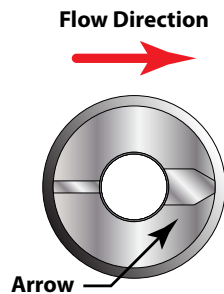

Figure 11: Flow direction arrow

1. Lubricate the O-rings located within the DP7 probe seal fitting so that the seals are not damaged during probe insertion.
2. Run the lower jam nuts down to a point that approximates the final insertion position or at least far enough to allow insertion into the insertion fitting.
3. Using the threaded rods as a guide, position the probe in the insertion fitting. Continue to insert the probe into the isolation assembly until the probe tip comes in contact with the closed “ball” in the isolation valve.

CAUTION

DO NOT FORCE THE PROBE TIP AGAINST THE “BALL”; AS DAMAGE TO THE PROBE TIP MAY RESULT.

4. Replace the upper jam nuts (2 on each rod) and the cotter pins. The nuts should be run down to the top side of the retaining collar and the cotter pins replaced.
5. Orient the probe in the direction of flow as indicated by the flow direction arrow located on the top of the probe flange.
6. Lock the probe in position with the enclosed Allen wrench.

CAUTION

THE NUTS ON BOTH ENDS OF THE RETAINING RODS MUST ALWAYS BE IN PLACE AS A SAFETY MEASURE TO PREVENT POSSIBLE PROBE BLOW OUT. INSERTING COTTER PINS IS A FURTHER SAFETY MEASURE.

7. Slowly open the isolation valve. When the valve is fully open, use the proper size wrench on the insertion nuts, alternately tightening each nut about two complete turns to avoid uneven seal loading.

TRANSMITTER INSTALLATION

Unpacking and Inspection

Upon opening the shipping container, visually inspect the product and applicable accessories for any physical damage such as scratches, loose or broken parts, or any other sign of damage that may have occurred during shipment.

NOTE: If damage is found, request an inspection by the carrier's agent within 48 hours of delivery and file a claim with the carrier. A claim for equipment damage in transit is the sole responsibility of the purchaser.

Mounting Location

The enclosure should be mounted in an area that is convenient for servicing, calibration and for observation of the LCD readout.

1. Locate the transmitter within the length of transducer cable that was supplied with the DFX system. If this is not possible, exchange the cable for one that is of proper length. While transducer cable extension is not generally recommended, if additional transducer cable length is required, use cable and connectors of the correct type and impedance. In many cases, especially if a splice may be exposed to water or other liquids, it may be more effective to replace the entire cable. Transducers use RG59,75 Ohm coaxial cable or Twinax (Belden #9463) or (Belden # 9463DB) 78 Ohm two-conductor cable.
 2. Mount the DFX flow meter in a location that is:
 - Free of vibration
 - Protected from falling corrosive fluids
 - Within ambient temperature limits – 40...185° F (– 40...85° C)
 - Out of direct sunlight. Direct sunlight may increase transmitter temperature to above the maximum limit
 3. See *Figure 12* for enclosure and mounting dimension details. Make sure there is enough room for door swing, maintenance and conduit entrances. Secure the enclosure to a flat surface with four appropriate fasteners.
 4. Use conduit hubs where cables enter the enclosure. Seal unused holes with plugs.
- NOTE:** Use NEMA 4 (IP-65) rated fittings/plugs to maintain the watertight integrity of the enclosure. Generally, the left conduit hole (viewed from front) is used for line power, the center conduit hole for transducer connections and the right hole is used for ISO-MOD I/O wiring.
5. If additional holes are required, drill the appropriate size hole in the enclosure's bottom. Use extreme care not to run the drill bit into the wiring or circuit cards.

Dimensions

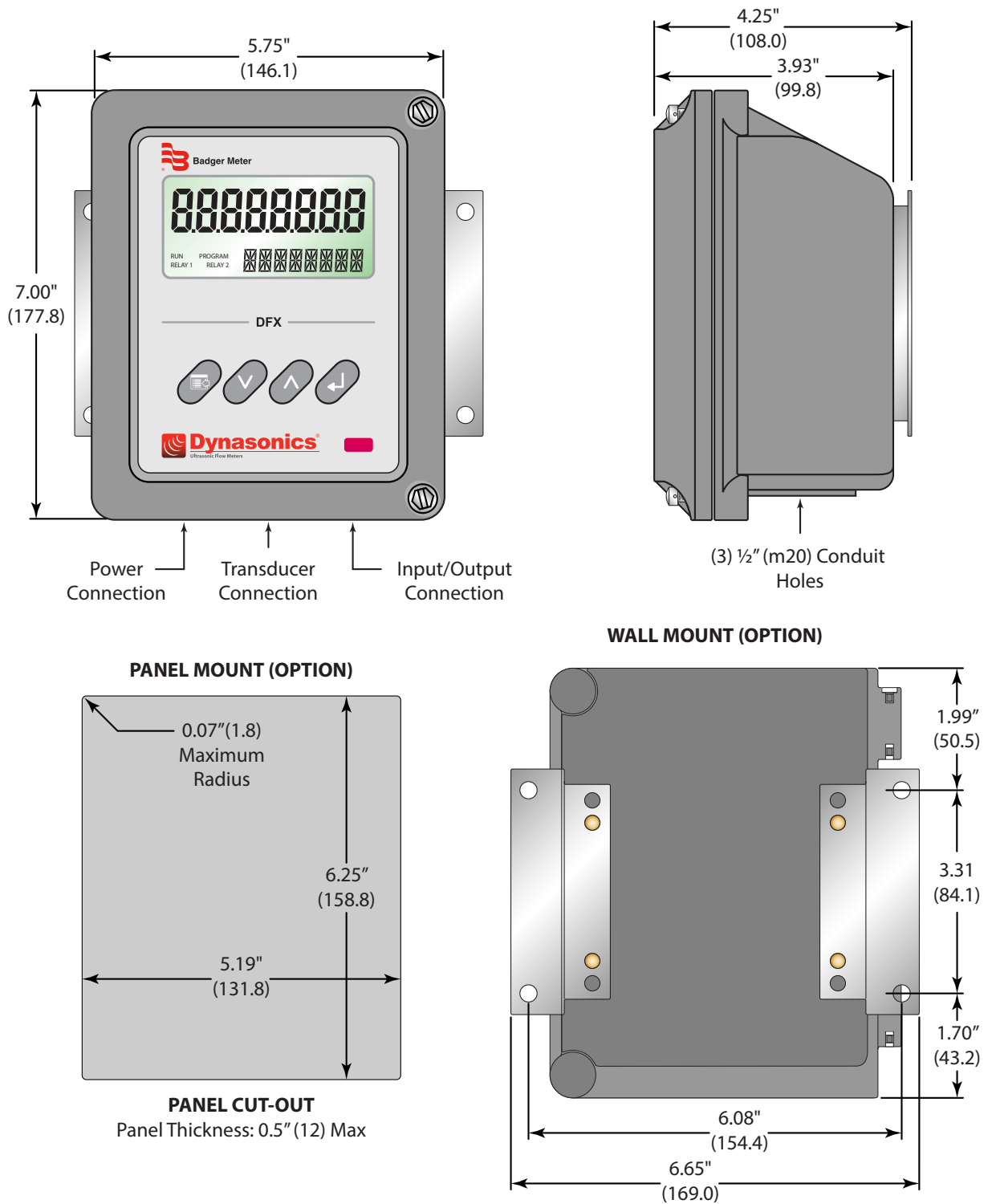

Figure 12: DFX transmitter installation dimensions

Transducer Wiring Connections

To access terminal strips for electronic connectors, loosen the two screws in the enclosure door and open the door.

1. Guide the transducer connectors through the middle conduit hole located of the transmitter enclosure. Secure the transducer cable with the supplied conduit nut (See *Figure 13*).

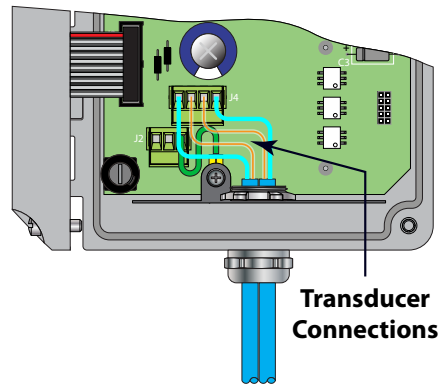

Figure 13: Transducer cable installation

The terminals within the DFX flow meter are removable. They can be unplugged, wired and then plugged back in.

2. Connect the wires to J4 at the corresponding screw terminals in the transmitter. See *Figure 14* or the Wiring Diagram located inside the door of the transmitter.

NOTE: The transducer cable carries low level, high frequency signals. While transducer cable extension is not generally recommended, if additional transducer cable length is required, use cable and connectors of the correct type and impedance. In many cases, especially if a splice may be exposed to water or other liquids, it may be more effective to replace the entire cable. Transducers use RG59, 75 Ohm coaxial cable or Twinax (Belden #9463) or (Belden # 9463DB) 78 Ohm two conductor cable. Cable lengths up to 990 feet (300 meters) are available.

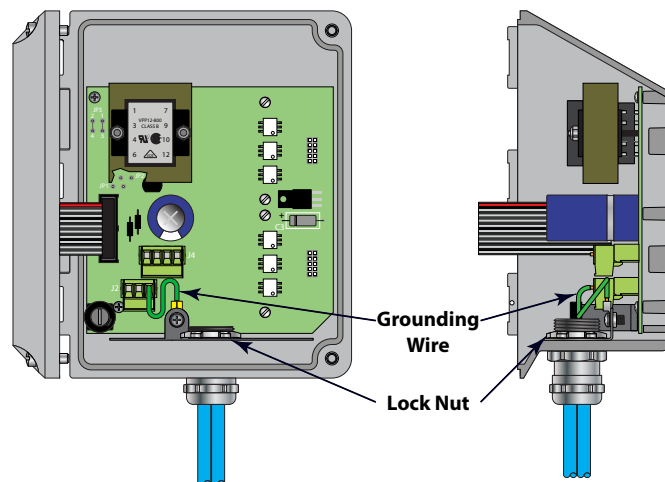

Figure 14: Transducer connections

Power Supply Wiring Connections

Connect power to the screw terminal block marked J2 through the conduit hole on the left side of the enclosure. See *Figure 15* for AC power supplies and *Figure 16* for DC power supplies. Use wiring practices that conform to local and national codes (for example, The National Electric Code Handbook in the U.S.).

CAUTION

ANY OTHER WIRING METHOD MAY BE UNSAFE OR CAUSE IMPROPER OPERATION OF THE INSTRUMENT.

DANGER

TO AVOID SERIOUS INJURY OR DAMAGE, DISCONNECT ELECTRICAL POWER BEFORE SERVICING THIS METER.

NOTE: This instrument requires clean electrical line power. Do not operate this unit on circuits with noisy components (such as fluorescent lights, relays, compressors or variable frequency drives). Do not run line power with other signal wires within the same wiring tray or conduit.

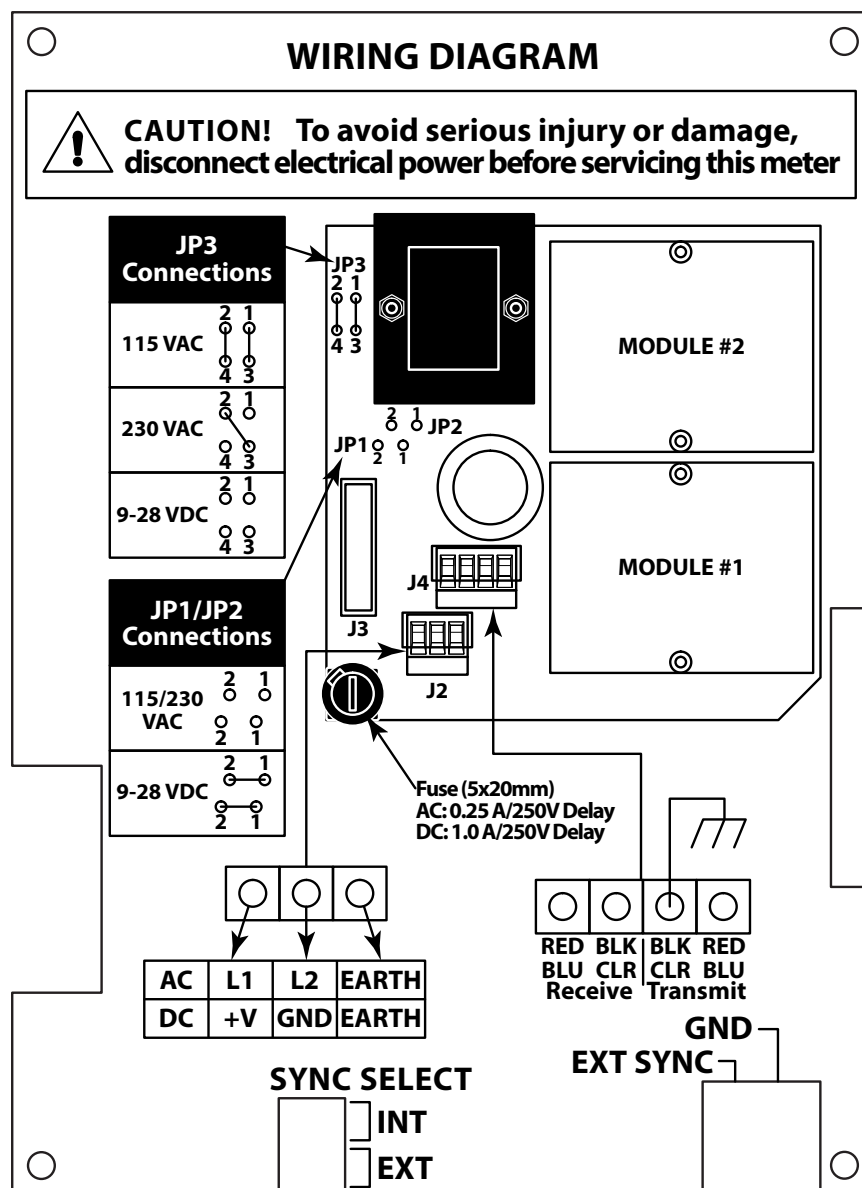

Figure 15: DFX flow meter wiring diagram

AC Power Supply Connections

⚠ DANGER

LINE VOLTAGES MAY BE PRESENT WITHIN THE ENCLOSURE. THERE IS A RISK OF SHOCK, SPARKS AND DEATH IF THIS PRODUCT IS HANDLED IN AN UNSAFE WAY. SERVICE SHOULD ONLY BE DONE BY QUALIFIED PERSONNEL.

1. Verify that the jumpers at JP3 are properly oriented for the power supply. See *Figure 15*.
2. Verify that the jumpers at JP1 and JP2 are not present.
3. Connect L1, L2 and EARTH to the terminals referenced in *Figure 15*. Phase and neutral connections to L1 and L2 are not polarized. Do not operate without an earth ground connection.
4. See *Figure 16* for AC connection schematic. Wire gauges up to 14 AWG can be accommodated in the DFX flow meter's terminal blocks.

NOTE: A switch or circuit breaker is required in the installation. The switch or circuit breaker must be in close proximity of the DFX flow meter and within easy reach of the operator. The switch or circuit breaker must be marked as the disconnect device for the DFX flow meter.

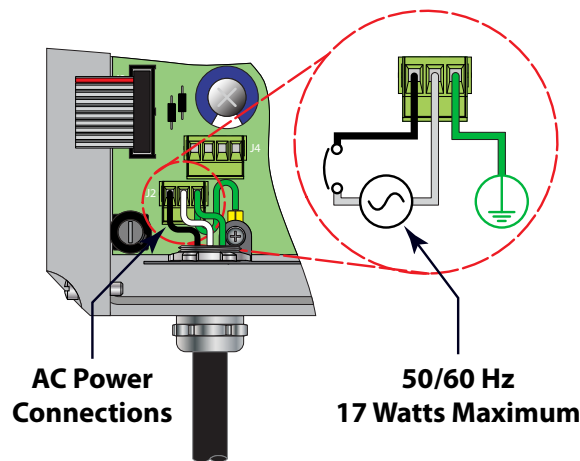

Figure 16: DFX flow meter AC power connection

DC Power Supply Connections

The DFX flow meter may be operated from a 12...28V DC source, as long as the source is capable of supplying 7 Watts.

- 12V DC Supply @ 600 mA minimum
 - 24V DC Supply @ 300 mA minimum
1. Verify that the jumpers are properly placed. See the wiring diagram inside the door of the DFX flow meter enclosure or see *Figure 15*. The jumpers at JP3 should not be present and the jumpers at JP1 and JP2 should be in place.
 2. Connect the DC power source as illustrated in the schematic in *Figure 17 on page 23*. Wire up to 14 AWG can be accommodated in the DFX flow meter terminal blocks.

NOTE: A switch or circuit breaker is required in the installation. The switch or circuit breaker must be in close proximity of the DFX flow meter and within easy reach of the operator. The switch or circuit breaker must be marked as the disconnect device for the DFX flow meter.

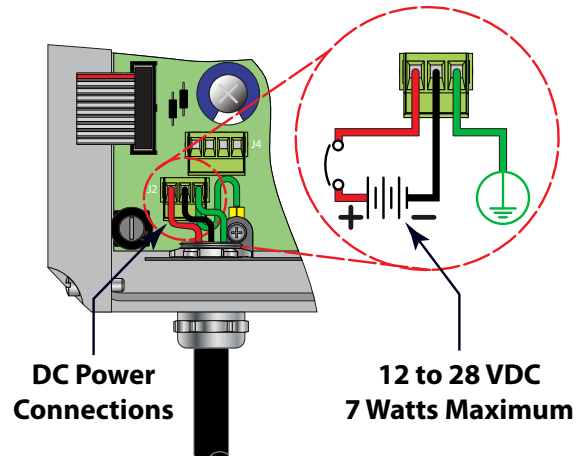

Figure 17: DC power connection

Multiple Meter Installations

The DFX flow meter contains a provision for synchronizing multiple DFX flow meters together. Synchronization is required when more than one DFX flow meter is mounted on a common pipe or header system. If the meters are not synchronized, a phenomena called “cross-talk” can occur between meters, which can lead to erroneous readings or no readings at all. Cross-talk results from the small differences in transmitted frequency generated from two or more different ultrasonic flow meters. By synchronizing the transmitted ultrasonic energy, cross-talk caused by differences in transmitted frequency is eliminated.

The DFX flow meter synchronization circuit is designed to interconnect up to four DFX flow meters over a cable length of 100 feet (30 meters). Use 20-22 AWG twisted-pair shielded interconnection wire for this purpose. See *Figure 18*.

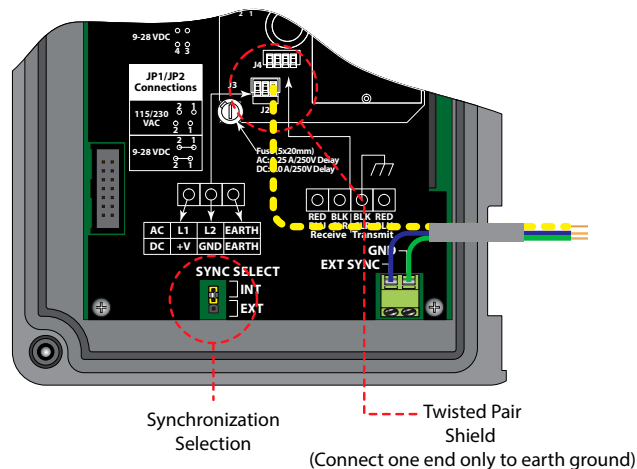

Figure 18: Meter synchronization detail

To Synchronize Multiple Meters

1. Remove power from the DFX flow meters.
2. Daisy-chain connect the **EXT**ernal **SYN**Chronization and GND terminal blocks together between the meters to be synchronized, using the twisted-pair cable described previously. The terminal block is located on the circuit board that is mounted on the door of the meter's monitor. See *Figure 15 on page 21* or the Wiring Diagram inside the door of the DFX monitor.
3. At a single point, connect the shield drain wire from the interconnection cable to earth ground.
4. Configure the SYNC SELECT jumpers on the DFX flow meters. One DFX flow meter should be configured for INT and the remaining units configured for EXT (see *Figure 19*).
5. Apply power to the DFX system.

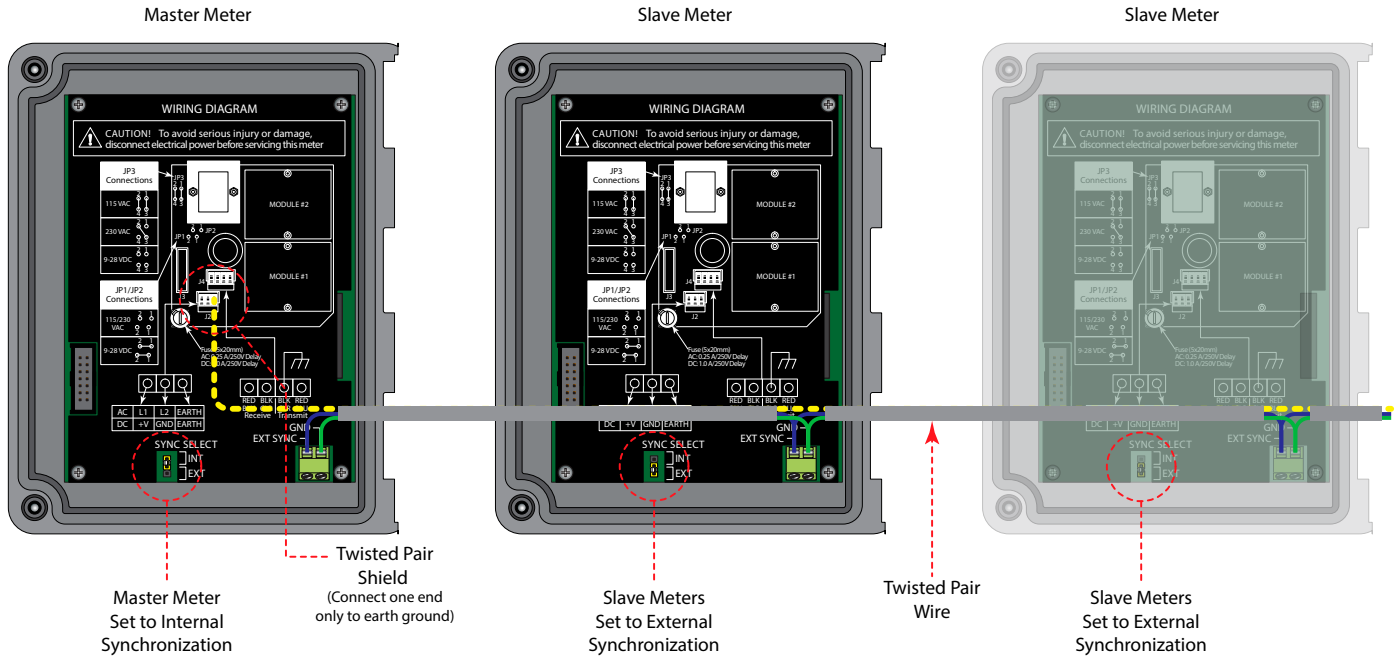

Figure 19: DFX flow meter synchronization connections

ISO Modules

The DFX flow meter uses ISO-MODs for input and output functions. ISO-MODs are epoxy encapsulated electronic input/output modules that are simple to install and replace in the field. See Figure 20. All modules are 2500 V optically isolated from the DFX flow meter’s power and earth grounds. This eliminates the potential for ground loops and reduces the chance of severe damage in the event of an electrical surge.

Three ISO-MOD options are available: 4...20 mA, dual-relay and rate pulse. The DFX flow meter supports any two ISO-MOD input/output modules. All modules are field-configurable by using the keyboard interface. Field wiring connections to ISO-MODs are quick and easy using removable wiring terminals. Configuration and connection of the various ISO-MODs are described on the following pages.

ISO Module Replacement

To remove an ISO-MOD, remove the two machine screws that secure the module in place and pull the module straight out of the enclosure. A 10-pin connection is on the bottom of the module that mates with the circuit board underneath. To install an ISO-MOD, push the module into the 10-pin connector and tighten the two machine screws. Re-calibrate the parameters if the 4...20 mA modules are replaced. See “Module Configuration Parameters” on page 35 for instructions.

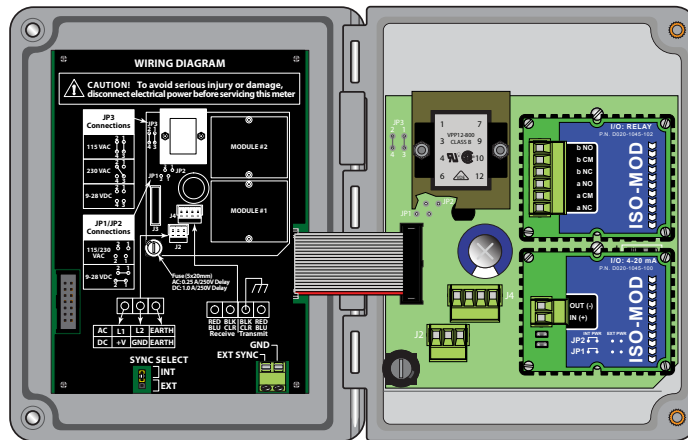

Figure 20: Two ISO-MOD I/O modules installed

4...20 mA Output Module

The 4...20 mA Output Module interfaces with most recording and logging systems by transmitting an analog current signal that is proportional to system flow rate. Configure the 4...20 mA ISO-MOD via jumper selections for an internally powered (Figure 22) or externally powered (Figure 23) module. Do not exceed the maximum load for a particular supply voltage. See Figure 21.

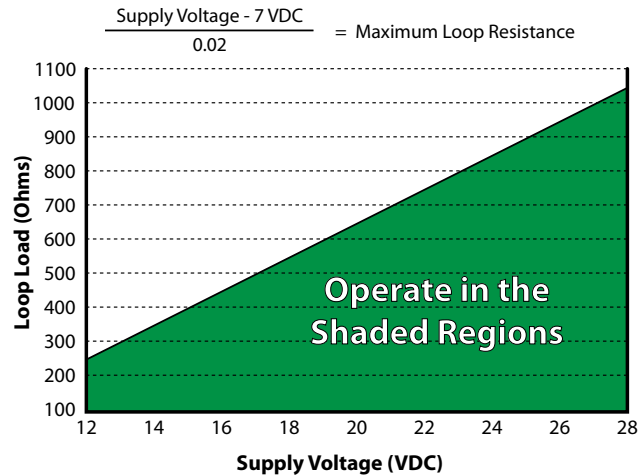

Figure 21: Maximum 4...20 mA loads

Internal Power Configuration

Verify that jumpers are in place at JP1 and JP2 on the module. See Figure 22 . In this configuration, the 4...20 mA output is driven from a +24V DC source located within the DFX flow meter. The 24V DC source is isolated from the DC ground and earth ground connections within the DFX flow meter. The module can accommodate loop loads up to 800 Ohms in this configuration.

NOTE: The +24V internal supply, if configured to power the 4...20 mA output, shares a common ground with another ISO-MOD (if installed). If another module is connected to earth ground, a ground loop may occur. The solution to this problem is to configure the 4...20 mA module for external power and use an external isolated supply to power the 4...20 mA loop.

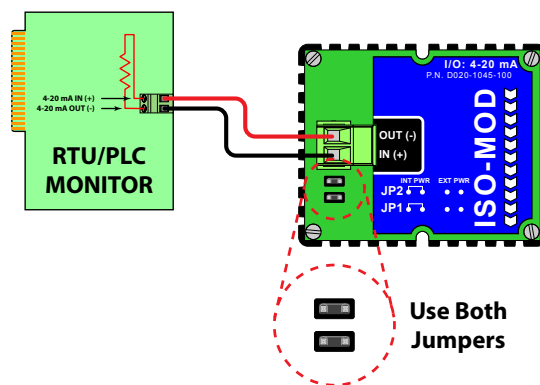

Figure 22: Internally powered 4...20 mA

External Power Configuration

Remove the two jumpers located at JP1 and JP2 on the module. See *Figure 23*. In this configuration, the 4...20 mA module requires power from an external DC power supply. The voltage of the external power source must be sufficient to power the module and drive the loop load. The loop loss attributed to the ISO-MOD is 7V DC, so the minimum voltage required to power a loop can be calculated using the following formula: Loop voltage (min) = (loop load Ohms × 0.02) + 7

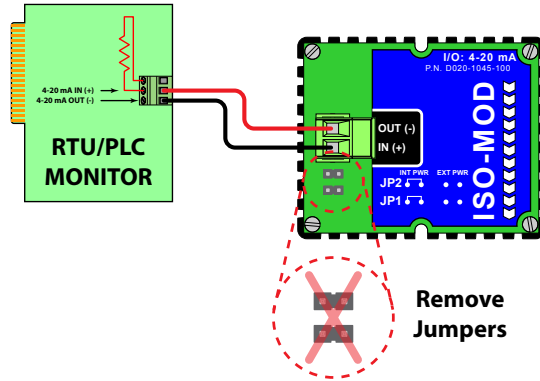

Figure 23: Externally powered 4...20 mA

Control Relay Output Module

Two independent SPDT (single-pole, double-throw, Form C) relays are contained in this module. The relay operations are user configured via the front panel to act in either a flow rate alarm, error alarm or totalizing pulse. The relays are rated for 200V AC maximum and have a current rating of 0.5 A resistive load (175V DC @ 0.25 A resistive). Use a secondary relay whenever the Control Relay ISO-MOD is used to control inductive loads such as solenoids and motors.

Typical relay connections are illustrated in *Figure 24*. The reed relays located within the relay module can interface directly with small pilot lights, PLCs, electronic counters and SCADA systems.

Figure 25 shows the connection of an external power relay to the Relay ISO-MOD. Use external power relays whenever the load to be switched exceeds the switch rating of the reed relays, or if the load is inductive in nature.

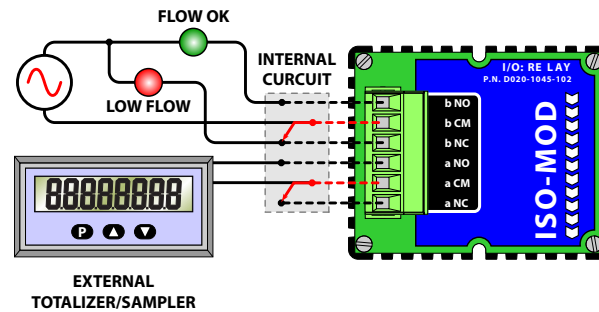

Figure 24: Typical relay connections

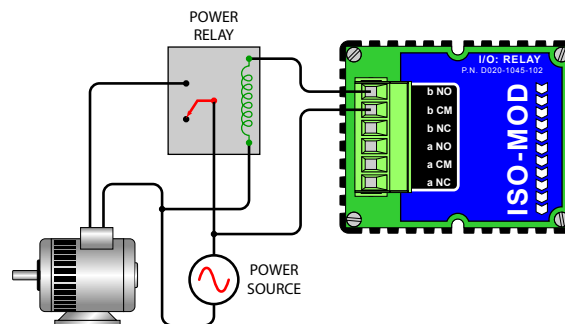

Figure 25: External relay connections

Rate Pulse Output Module

The Rate Pulse Output Module is used to transmit information to external counters and PID systems via a frequency output that is proportional to system flow rate. The frequency output range of the Rate Pulse Module is 0...2500 Hz. This module has two types of outputs: one simulates the output of the coil of a turbine flow meter and the other is an open-collector type that does not source voltage at its output. Both outputs may be connected simultaneously.

The turbine meter output creates a 500 mV peak-to-peak saw-tooth waveform that is not referenced to ground. This output can be run to electronic monitors that are compatible with variable reluctance outputs from coils, such as those found in turbine and paddle-wheel flow meters. The input impedance of the receiving device should not be smaller than 2000 Ohms.

The standard pulse output does not output a voltage, but acts as an open-collector output requiring an external power source and pull-up resistor. See *Figure 26*. The MOSFET in the Rate Pulse Module can support loads of 100V @ 1 A. Resistor selection is based on the input impedance of the receiving device. Select a resistor that is a maximum of 10% of the input impedance of the receiving device, but does not exceed 10k Ohms.

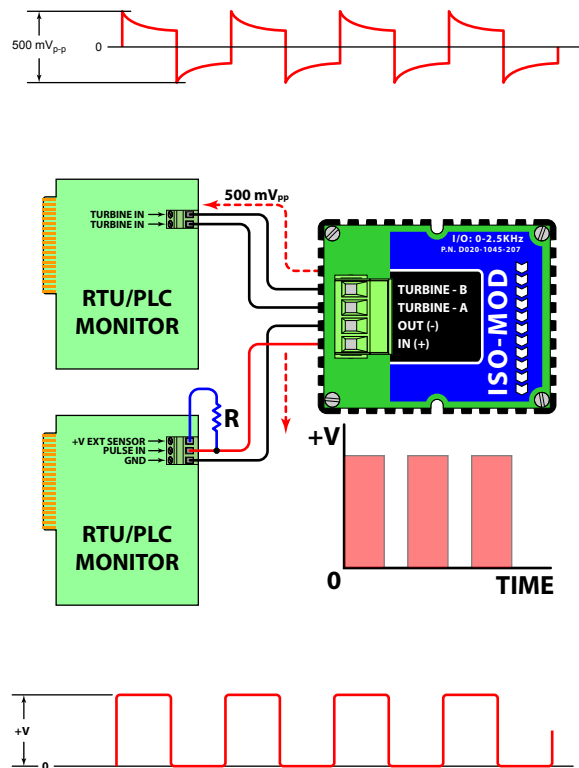

Figure 26: Rate pulse module

INSTRUMENT PROGRAMMING

General

The DFX flow meter is configured through the keypad interface. All entries are saved in non-volatile FLASH memory that is retained indefinitely in the event of power loss.

Keypad Operation

The DFX flow meter contains a four-key tactile feedback keypad interface that lets you view and change configuration parameters used by the meter's operating system.



Figure 27: Keypad layout

The DFX flow meter has two basic sets of programming procedures: list item selection and numeric value entry.

NOTE: While in RUN mode, simultaneously press the UP and DOWN keys to display the current firmware version.

List Item Selection Procedure

NOTE: If you are in *PROGRAM* mode and the selection to be viewed or changed is displayed, proceed to step 3 below. If you are in *PROGRAM* mode and the selection to be viewed or changed is not displayed, press **UP** or **DOWN** until the selection appears. Proceed to step 3.

1. Press **MENU**. *PROGRAM* appears in the lower left-hand corner and *ID UNITS* appears on the lower line of the display.
2. Press **DOWN** to move to the selection.
3. Press **ENTER** to view the current selection.
4. If the current selection is correct, press **ENTER** to confirm. The unit automatically advances to the next selection.
5. To change the current selection, press **UP** to scroll through the available choices. Press **ENTER** to confirm your selection. The unit automatically advances to the next selection.
6. To exit the programming mode, press **MENU**. Depending on your position in the programming mode, up to three **MENU** presses may be required to exit. The display changes to *RUN* mode.

NOTE: While in RUN mode, simultaneously press the **UP** and **DOWN** keys to display the current firmware version.

Numeric Value Entry Procedure

NOTE: If you are in *PROGRAM* mode and the selection to be viewed or changed is displayed, proceed to step 3 below. If you are in *PROGRAM* mode and the selection to be viewed or changed is not displayed, press **UP** or **DOWN** until the selection appears. Proceed to step 3.

1. Press **MENU**. *PROGRAM* displays in the lower left corner and *ID UNITS* displays on the lower line.
2. Press **DOWN** until the correct selection displays. The current numeric value for this selection displays on the upper line.
3. If the current value is correct, press **ENTER**. The left-most programmable number flashes. Press **ENTER** again to confirm and keep the current numeric value. The unit automatically advances to the next menu selection.
4. To change the current selection, press **ENTER**. The left-most programmable number flashes. Press **UP** to scroll through the digits 0...9. Press **DOWN** to move the active digit to the right. Continue until all digits are selected.
5. Press **ENTER** to confirm your selection. The unit automatically advances to the next selection.
6. To exit the programming mode, press **MENU**. Depending on your position in the programming mode, up to three **MENU** presses may be required to exit. The display changes to *RUN* mode.

Totalizer Reset

Press **ENTER** and **MENU** simultaneously when in the *RUN* mode to reset the totalizer. The message *TOTAL RST* displays for a few seconds to indicate that the totalizer had been cleared. If a password has been set, you must enter the password to clear the totalizer.

MENU STRUCTURE

Hierarchy

The DFX flow meter has a hierarchical menu structure. See “Menu Maps” on page 31 for a visual path to the configuration parameters. Use the table below as a quick reference guide to the pages with detailed information on each parameter.

Setup Parameters	Options	For Details, see page	Advanced Setup Parameters	Options	For Details, see page	Module Configuration Parameter	Options	For Details, see page
ID UNIT →	INCH	33	AD SETUP →	YES	36	CFG MOD1 →	YES	34
	MM	33		NO	36		NO	34
ID →	(numeric entry)	33	AGC MODE →	NORMAL	36	CFG MOD2 →	YES	35
DISPLAY →	RATE	33		HIGH	36		NO	35
	TOTAL	33		MANUAL	36	MOD TYPE →	NONE	35
BOTH	33	GAIN POT →	(numeric entry)	36	4-20MA		25, 35	
DIA	33		FILTER →	NONE	36		RATE	28, 35
RATE UNT →	GALLONS	33	LOW	36	RELAY	27, 35		
	LITERS	33	MEDIUM	36	FLOW 4MA →	(numeric entry)	35	
	MGAL	33	HIGH	36		FLOW 20MA →	(numeric entry)	35
	CUBIC FT	33	XDCR TYP →	DT90	36	4-20 CAL? →	YES	35
	M CU FT	33		PROBE	36	NO	35	
	CUBIC ME	33	C FACTOR →	(numeric entry)	36	4MA OUT →	(numeric entry)	35
	MEG LTRS	33		LINEAR →	YES	36	20MA OUT →	(numeric entry)
	ACRE FT	33	NO	36	4-20TEST →	(numeric entry)	35	
	OIL BARR	33	NUM PTS →	(numeric entry)	36	RATE →	NONE	35
	LIQ BARR	33		FREQ n →	(numeric entry)	36	TOTAL	35
	LBS	33	COEFF n →	(numeric entry)	36	FLOW	35	
	KGS	33				ERRORS	35	
	VEL FT	33			n OFF →	(numeric entry)	35	
	VEL MTRS	33			n ON →	(numeric entry)	35	
	RATE INT →	SEC	33			FLOW OHZ →	(numeric entry)	35
		MIN	33			FLOW MAXHZ →	(numeric entry)	35
		HOUR	33			RATE TST →	(numeric entry)	35
DAY		33			RATE PCT →	(numeric entry)	35	
TOTL UNT →	GALLONS	33						
	LITERS	33						
	MGAL	33						
	CUBIC FT	33						
	M CU FT	33						
	CUBIC ME	33						
	MEG LTRS	33						
	ACRE FT	33						
	OIL BARR	33						
	LIQ BARR	33						
	LBS	33						
	KGS	33						
	VEL FT	33						
	VEL MTRS	33						
	TOTL MUL →	X PT 01	33					
		X PT 1	33					
		X 1	33					
X 10		33						
X 100		33						
X 1000		33						
X 10000		33						
X 100000		33						
X 1000000		33						
X 10000000		33						
SP GRAV →	(numeric entry)	33						
FL C OFF →	(numeric entry)	33						
SCALE F →	(numeric entry)	34						
DAMPING →	(numeric entry)	34						
PASSWORD →	(numeric entry)	34						

Menu Maps

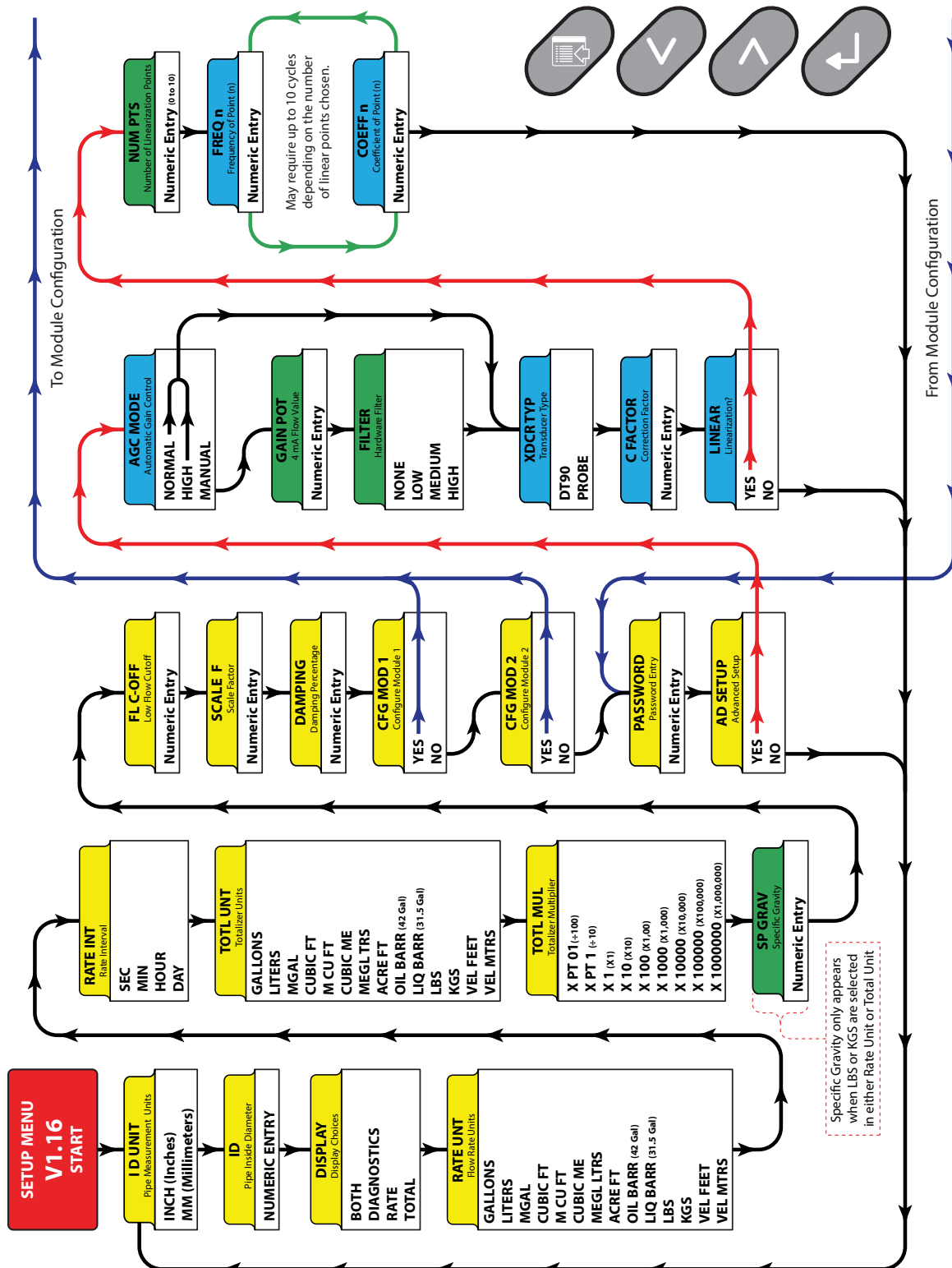

Figure 28: Menu Map 1

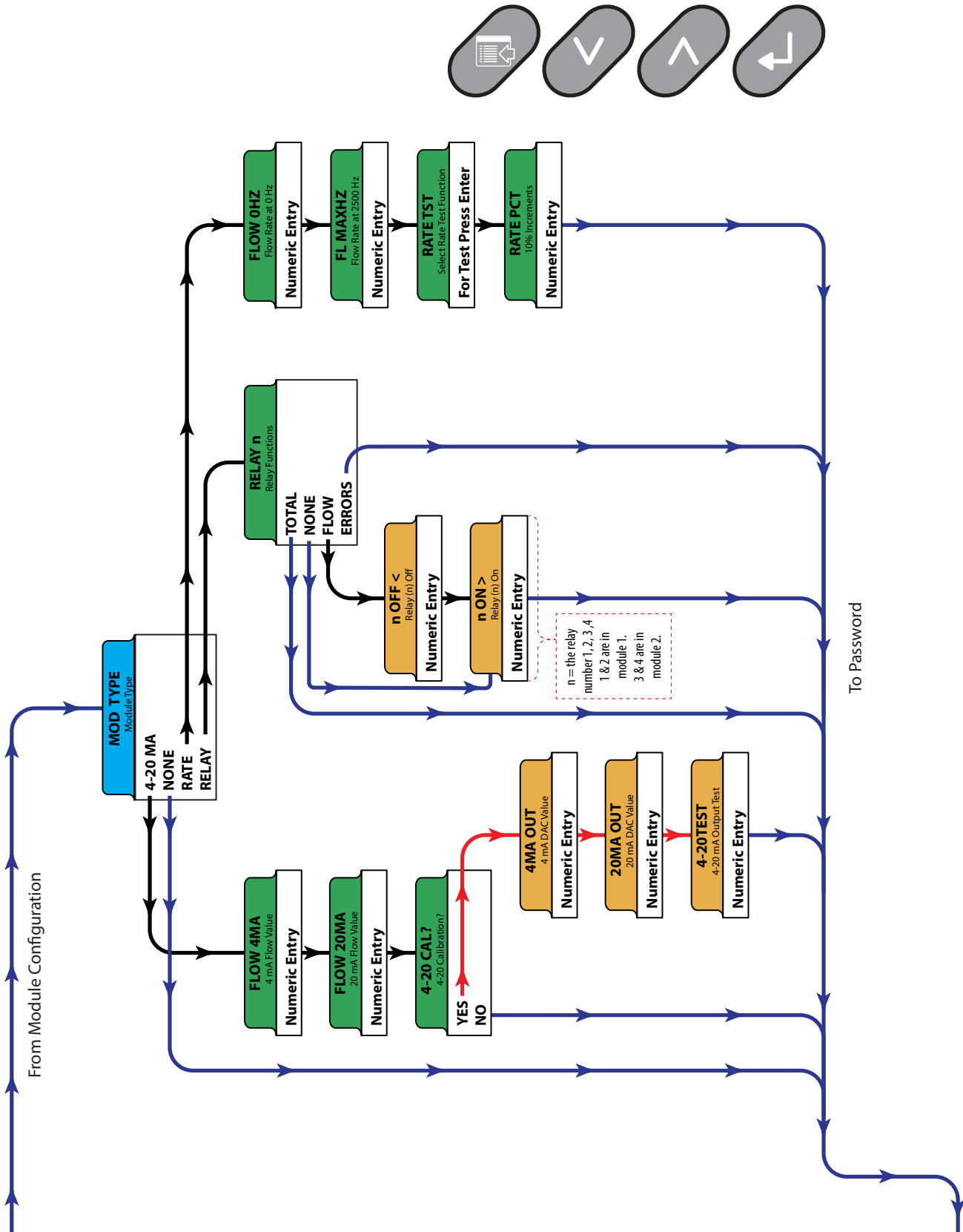

Figure 29: Menu map 2

PARAMETERS

The following tables list and explain the parameters. The tables are divided into three main sections:

- Setup parameters
- Module configuration parameters
- Advanced setup parameters

Setup Parameters

The setup menu contains all of the configuration parameters necessary to make the transmitter operational.

Parameter	Function	Options	Description	
ID UNITS	Measurement standard	ENGLISH (Inches) METRIC (Millimeters)	Selects the unit of measure for pipe ID entry.	
ID	Pipe inside diameter	(Enter a numeric value)	Enter the pipe inside diameter in inches if <i>ENGLISH</i> was selected as <i>UNITS</i> ; in millimeters if <i>METRIC</i> was selected.	
DISPLAY	Display mode	RATE TOTAL BOTH DIA	To display only the Flow Rate, select RATE . To display only the Flow Total, select TOTAL . To alternately display the Flow Rate and the Total, select BOTH . By selecting BOTH , the display switches between RATE and TOTAL every 7 seconds. The DIA selection places the display in the diagnostics mode. When selected, the display shows the measured frequency, the gain setting and the signal strength.	
RATE UNT	Engineering units for flow rate	Select an engineering unit for flow rate measurements. When Pounds (LBS) or Kilograms (KGS) is selected, the specific gravity for the fluid type must be entered for the SP GRAV setup parameter.		
		Measurement	Selection	
		Pounds	LBS	
		Kilograms	KGS	
		Gallons	GALLONS	
		Liters	LITERS	
		Millions of Gallons	MGAL	
		Cubic Feet	CUBIC FT	
Millions of Cubic Feet	MCU FT			
RATE INT	Time interval for flow rate	SEC Seconds MIN Minutes HOUR Hours DAY Days	Select a time interval for flow rate measurements.	
TOTL UNT	Totalizer units	Select an engineering unit for flow totalizer measurements. When Pounds (LBS) or Kilograms (KGS) is selected, the specific gravity for the fluid type must be entered for the SP GRAV setup parameter.		
		Measurement	Selection	
		Pounds	LBS	
		Kilograms	KGS	
		Gallons	GALLONS	
		Liters	LITERS	
		Millions of Gallons	MGAL	
		Cubic Feet	CUBIC FT	
Millions of Cubic Feet	MCU FT			
TOTL MUL	Flow totalizer multiplier value	0.01...1,000,000	Used for setting the flow totalizer exponent. This feature is useful for accommodating a very large accumulated flow. The exponent is a $\times 10^n$ multiplier, where "n" can be from -2 ($\times 0.01$) to +6 ($\times 1,000,000$). Reference the table below for valid entries and their influence on the DFX meter display.	
			Exponent	Display Multiplier
			$\times PT 01 (-2)$	$\times 0.01$
			$\times PT 1 (-1)$	$\times 0.1$
			$\times 1 (0)$	$\times 1$
			$\times 10 (1)$	$\times 10$
			$\times 100 (2)$	$\times 100$
			$\times 1000 (3)$	$\times 1000$
			$\times 10000 (4)$	$\times 10,000$
			$\times 100000 (5)$	$\times 100,000$
$\times 1000000 (6)$	$\times 1,000,000$			
SP GRAV	Fluid specific gravity	(Enter a numeric value)	Allows adjustments to be made to the specific gravity (density relative to water) of the liquid. If Pounds (LBS) or Kilograms (KGS) is selected for either the RATE UNT or the TOTL UNT, a specific gravity must be entered for the correct mass flow to be calculated. A list of fluids and their associated specific gravities is located in "Specifications" on page 40.	
FL C-OFF	Low flow cutoff	(Enter a numeric value)	A Low Flow Cutoff entry is provided to allow very low flow rates (that can be present when pumps are off and valves are closed) to be displayed as Zero flow. The value entered is in <i>actual rate units</i> .	

Parameter	Function	Options	Description
SCALE F	Scale factor value	(Enter a numeric value)	<p>The SCALE F function applies a correction factor/multiplier to the readings and outputs so the DFX system can agree with a different or reference flow meter, or to compensate for an installation where there is inadequate straight pipe to obtain a laminar flow profile. A factory calibrated system should be set to 1.000. The range of settings for this entry is 0.5000...5.000. The following example describes using the SCALE F entry.</p> <p>The DFX meter is indicating a flow rate that is 4% higher than another flow meter located in the same pipe line. To have the meter indicate the same flow rate as the other meter, enter a SCALE F of 0.960, to lower the readings by 4%.</p>
DAMPING	System damping percentage	(Enter a numeric value 0...99%)	<p>Flow Filter Damping establishes a maximum adaptive filter value. Under stable flow conditions (flow varies less than 10% of reading), this adaptive filter increases the number of successive flow readings that are averaged together up to this maximum value. If flow changes outside of the 10% window, the Flow Filter adapts by decreasing and allows the meter to react faster. Increasing this value tends to provide smoother steady-state flow readings and outputs.</p>
CFG MOD1	Configure I/O Module	YES or NO	<p>This prompt lets you access the setup parameters associated with installation of the optional ISO-MOD interface modules. If NO is selected, the unit skips ahead to CFG MOD2. If YES is selected, configuration and calibration of the module installed in the first position is accessible.</p>
CFG MOD2	Configure I/O Module	YES or NO	<p>If NO was selected at CFG MOD1, CFG MOD2 becomes active. This prompt lets you access the setup parameters associated with installation of the optional ISO-MOD interface modules. If NO is selected, the unit skips ahead to PASSWORD. If YES is selected, configuration and calibration of the module installed in the second position is accessible.</p>

Module Configuration Parameters

When **YES** is selected at CFG MOD1 or CFG MOD2, these MOD TYPE parameters become available:

- NONE
- 4...20 mA
- RATE
- RELAY

Once the module is configured, the menu moves to the PASSWORD parameter.

MOD TYPE	Function	Options	Description
NONE	No module is installed	NONE	Select NONE (no module installed) to move to the PASSWORD parameter.
4-20MA	4...20 mA type module	FLOW 4MA	Enter the flow rate that corresponds to 4 mA. The units are equal to the units set in RATE UNT.
		FLOW 20MA	Enter the flow rate that corresponds to 20 mA. The units are equal to the units set in RATE UNT.
		4-20 CAL?	Select NO to move to the PASSWORD parameter.
			Select YES to adjust the "zero" and span of the 4...20 mA output.
			To adjust either the 4 mA or 20 mA output, connect a milliammeter or reliable reference to the output.
4MA OUT	1. Disconnect one side of the current loop and connect the milliammeter in series (disconnect either wire at the terminals labeled +/- on the ISO-MOD 4...20 mA module).		
20MA OUT	2. Using the arrow keys, increase the numerical value to increase the current in the loop to the output. Decrease the value to decrease the current in the loop to output. The value range for 4MA OUT is 40...80 counts. The value range for 20MA OUT is 3700...3900 counts.		
4-20TEST	3. Re-connect the 4...20 mA output circuitry as required.		
			Outputs a simulated value from the 4...20 mA output. By incrementing this value, the 4...20 mA output transmits the indicated current value.
RATE	Rate pulse output module	FLOW 0Hz	Enter the flow rate that corresponds to 0 Hz. The units are equal to the units set in RATE UNT.
		FL MAXHZ	Enter the flow rate that corresponds to 2500 Hz. The units are equal to the units set in RATE UNT.
		RATE TST	Simulate a pulse output. Moves to RATE PCT entry.
		RATE PCT	Allows a simulated value to be output from the rate pulse output. By incrementing this value, the rate pulse output transmits the indicated frequency in terms of percentage of the maximum output frequency. For example, if the maximum output frequency is 2500 Hz, increment the displayed value to 50 to output a test frequency of 1250 Hz.
RELAY	Relay 1 and Relay 2 configuration	NONE	Select NONE (no Relay 1 installed) to move to the Relay 2 parameter.
		TOTAL	TOTAL mode configures the relay to output a 50 m/s pulse (contact changeover) each time the display totalizer increments. Select TOTAL to configure the relay for Totalizer Relay and move to the PASSWORD menu.
		FLOW	Flow Rate Relay configuration permits relay changeover at two separate flow rates allowing operation with an adjustable switch deadband. <i>Figure 30 on page 37</i> illustrates how the setting of the two set points influences Rate Alarm operation. A single-point flow rate alarm would place the ON> setting slightly higher than the OFF< setting—allowing a switch deadband to be established. If a deadband is not established, switch chatter (rapid switching) may result if the flow rate is very close to the switch point.
		ERRORS	When a relay is set to ERROR mode, the relay activates when any error occurs in the flow meter that has caused the meter to stop measuring reliably. See "Startup and Troubleshooting" on page 38 for a list of potential errors.

Advanced Configuration Parameters

Parameter	Function	Options	Description
PASSWORD	Change the security password	0...9999	By changing the Security Password from 0000 to some other value (any value between 0001...9999), configuration parameters are not accessible without first entering that value when prompted. If the value is left at 0000, no security is invoked and unauthorized changes could be made. Access to resetting of the Totalizer is also protected by this password.
AD SETUP (continued on next page)	Advance setup mode Select YES to access these parameters: AGC MODE GAIN POT FILTER LINEAR (continued on next page)		<p><i>AGC MODE – Automatic Gain Control Mode of Operation</i> NORMAL – Standard Configuration HIGH – Used for low signal strength MANUAL – AGC disabled GAIN POT – Digital Gain Control FILTER – Hardware Filter Control</p> <p>Select the mode of operation. A basic understanding of the AGC logic is required in order to know when to use any selection other than NORMAL.</p> <p>When the unit is powered up, there is a delay before the unit begins transmitting sound into the pipe. During this time, the signal strength is measured and a base signal level is obtained. Typically this is a value of about 20. The unit measures flow by measuring the Doppler frequency shift. The frequency shift is approximately 70 Hz per foot per second. For every foot per second increase in velocity, the signal strength should increase by 1. The unit automatically adjusts the gain and selects the proper hardware filter for the measured velocity. The control can be observed when the DISPLAY mode is set to DIAG. See <i>Figure 31 on page 38</i>.</p> <p>Manual Operations When NORMAL is selected, the unit automatically controls the gain and front end hardware filter for optimum measurement of the Doppler signal.</p> <p>Select HIGH for applications where the unit reads flow rates consistently, but much lower than the actual flow rate. This may be required when sound is not getting through the pipe as well. Selecting HIGH causes the unit to look for the signal strength to increase by 2 for every foot per second increase in flow rate. Basically, the gain is doubled, but still automatically controlled.</p> <p>Select the MANUAL mode for applications where the flow is constant but there is extraneous noise to filter out. Typically, this would only be required at very low flow rates. When MANUAL mode is selected, the GAIN POT and FILTER settings are manually set. Automatic control is disabled.</p> <p>Gain Control <i>GAIN POT – Digital Gain Pot</i> 0...64</p> <p>Using the arrow keys, increase or decrease the numerical value to set the signal gain level. Typically, optimum flow measurement is made when this value is 10...50. Use the lowest value that provides an accurate and stable flow reading. This adjustment must be made in conjunction with the FILTER setting.</p>

Parameter	Function	Options	Description
AD SETUP (continued from previous page)	Advance setup mode Advance setup mode Select YES to access these parameters: AGC MODE GAIN POT FILTER LINEAR	Hardware Filter <i>FILTER – Hardware Filter Selection</i> NONE – No Filter LOW – (1600 Hz Cutoff) MEDIUM – (350 Hz Cutoff) HIGH – (250 Hz Cutoff) Transducer Type <i>XDCR TYPE – Transducer Type</i> DT9 – Clamp-on Transducers PROBE – DP7 Insertion Probe Transducer	<p>Select the hardware filter with a cutoff frequency that is above the Doppler shift frequency to be measured. The Doppler shift frequency is found by multiplying the flow velocity (in FPS) by 80. For example, if the flow velocity is 4 FPS then the cutoff frequency is 4×80 or 320 Hz. The filter with the next highest frequency would be 350 Hz.</p> <p>Select the appropriate transducer type to be connected to the DFX transmitter. The selection invokes optimum hardware and software settings unique to the transducer architecture.</p> <p>Correction Factor <i>C FACTOR – Transducer Type</i> 0.01...5.00</p> <p>This value is established at the factory during calibration. If a new set of transducers or insertion probe is connected, the new correction factor should be entered. The correction factor values can be found on transducers or probes labels.</p> <p>Linearization <i>LINEAR – Entry of Linearization Data</i></p> <p>The Linearization feature corrects flow readings influenced by non-linear flow measurement. This typically occurs when there is insufficient straight piping before or after the location where the transducers are mounted.</p> <p>Up to 10 linearization points may be entered. The microprocessor performs a linear interpolation between data points entered in the linearization table and apply the associated correction factor to the measured flow rate.</p> <ol style="list-style-type: none"> 1. Enter the number of linearization points at the NUM PTS prompt. If a value of 00 is entered, linearization is disabled. The unit prompts for FREQ 1 to be entered. 2. Enter the measured frequency corresponding to the flow rate for the first point. This can be obtained by running actual flow with the DISPLAY mode set to DIAG and reading the measured frequency, or by calculating the frequency if the flow rate in feet per second is known using the following formulas: DT9 CLAMP-ON TRANSDUCER: $FREQ = VELOCITY (FPS) \times 80 HZ$ DP7 INSERTION PROBE TRANSDUCER: $FREQ = VELOCITY (FPS) \times 80 HZ$ <p>The unit prompts for COEFF 1 to be entered. This is the multiplication factor for the measured flow rate.</p> <ol style="list-style-type: none"> 3. Enter the coefficient or correction factor to be applied. The value entered must be between 0.5...1.5. 4. Repeat this procedure for all of the linearization points. When all of the points have been entered, the unit returns to the NUM PTS prompt. 5. Press MENU to return to the main menu LINEAR prompt. Then press UP or DOWN to move to the next setup parameter.
(continued from previous page)			

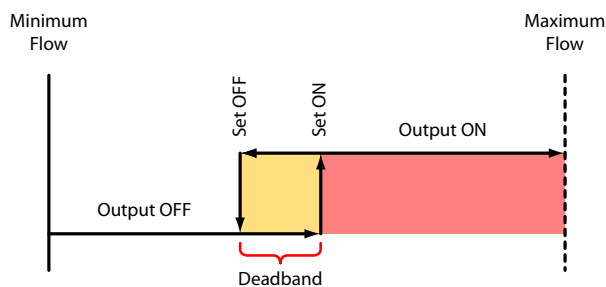

Figure 30: Single point alarm operation

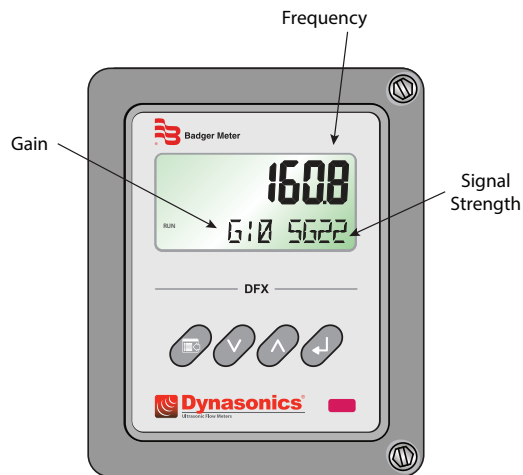

Figure 31: Diagnostic display

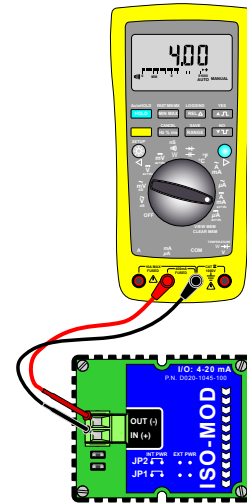

Figure 32: 4...20 mA calibration setup

STARTUP AND TROUBLESHOOTING

NOTE: The DFX flow meter system requires a full pipe of flowing liquid before a successful startup evaluation can be completed. Do not attempt to make adjustments or make manual configuration changes until a full pipe of flowing liquid is verified.

NOTE: If an RTV sealant was used to couple the transducers to the pipe, the sealant must fully cure before power is applied to the instrument. Most RTVs require 24 hours to cure satisfactorily. It is very important that the transducers are not moved during the curing process. Air bubbles can form between the transducer and the pipe wall and influence performance. If silicone grease was used as a couplant, the curing time is not required.

Startup

1. Verify that the DT9 or DP7 transducer has been properly installed and wired. See *"Transducer Installation"* on page 10.
2. Verify that the power supply jumper settings are properly configured for the power supply. See *"Power Supply Wiring Connections"* on page 21.
3. Verify that the meter is properly programmed. See *"Instrument Programming"* on page 29.
4. Apply power.
5. On initial powerup, the DFX meter's microprocessor conducts a series of self-diagnostic tests, baseline measurements and begins to buffer liquid velocity data. During this 30-second startup, flow rate readings and outputs are inhibited.
6. After the startup routine has completed running, the meter begins to display flow rate and/or total as configured.
7. If an ERROR appears on the monitor's lower display, see *"Troubleshooting"* on page 39.

Troubleshooting

Symptom	Cause/Resolution
Display does not light up	<ul style="list-style-type: none"> • Insufficient power to monitor. Measure voltage at J2. • Power supply not properly wired to J2. See <i>"Power Supply Wiring Connections"</i> on page 21. • Fuse F1 is open or not installed. • Power supply jumpers are not installed properly. See <i>"Power Supply Wiring Connections"</i> on page 21.. • Ribbon cable between the door and enclosure back is not fully engaged into the two sockets.
ERROR on the DFX flow meter display	<ul style="list-style-type: none"> • Transducers not properly coupled to the pipe. Couplant is not present or pipe not properly prepared. • Transducer not properly wired to the J4 Terminal block inside the meter. Review the Wiring Diagram on the inside door of the DFX meter. • More than one DFX meter is installed on the piping system. See <i>"Multiple Meter Installations"</i> on page 23. • Insufficient particles over 35 microns. Inject air upstream of the transducers. • Too many particles that are smaller than 35 micron prevent ultrasonic meters from operating. • Transducer failure. Unplug transducer cable from J4, measure capacitance between blue/clear or red/black Receive and Transmit. Verify that the capacitance on each set is approximately 2 nF (nano Farads) and within 0.02 nF of each other.
Unstable flow reading	<ul style="list-style-type: none"> • Relocate transducer to a pipe position with less hydraulic disturbance. • Increase Damping value. • Ensure that ground connection is properly connected to meters earth ground. See <i>Figure 13</i>.
Inaccurate flow reading	<ul style="list-style-type: none"> • Verify that pipe ID is entered correctly. • Verify that an erroneous Scale Factor has not been entered. • Verify that erroneous Linearization values have not been entered. • Verify that AGC is set to Normal. • Verify that the transducers are mounted square and 180 degrees apart on the pipe. • Relocate transducer to a pipe position with greater straight run length. • DP7 Probe not aligned in the pipe.
Analog output does not match data collection system	<ul style="list-style-type: none"> • Verify 4...20 mA calibration. • Verify 4 mA and 20 mA flow settings. Verify that the loop load is within the supply voltage range • Run 4...20mA TEST feature to verify that mA outputs coincide with expected data collection system readings.
Rate Pulse output does not match data collection system	<ul style="list-style-type: none"> • Verify 0 Hz and MAX Hz flow settings. • Place oscilloscope or frequency counter on the Rate Pulse module outputs and verify frequency output. • Run output TEST feature to verify that the Hz output coincides with expected data collection system readings. • Verify that the K-factor has been calculated correctly: $K\text{-factor} = \text{Hz}/(\text{flow}/\text{second})$ Example: Max Hz (2500 Hz) = 10,000 Gallons/Minute $K\text{-factor} = 2,500 \text{ Hz} / 166.7 \text{ Gallons/Second}$ $K\text{-factor} = 15 \text{ pulses/gallon}$ • Verify that the data collection system is accepting the pulses from the meter. Connect to Turbine OUT or OUT/IN as required.
DFX flow meter does not capture short flow pulses	<p>When run in AUTO mode, the meter uses a series of filters that optimize readings for a particular flow range. The flow meter takes several seconds to adjust to a step change in flow. To make the flow meter respond quickly to changes in flow, decrease DAMPING, place the meter into MANUAL AGC and lock the FILTER at NONE.</p>

SPECIFICATIONS

Velocity Range	0.15...30 fps (0.05...9 mps)	
Accuracy	±2% full scale, over calibrated span	
Liquid Types	Liquids containing a minimum of 100 ppm of useful sonic suspended reflectors greater than 35 micron size, and at least 25% of the overall particle volume is larger than 100 microns	
Monitor Enclosure	NEMA 4X (IP 66), polycarbonate, stainless steel, brass, plated-steel mounting brackets 7.00 in. H × 5.75 in. W × 3.88 in. D (178 mm × 146 mm × 99 mm)	
Power Supply	115/100/230V AC 50/60 Hz ±15% @ 17V A max; 12...28V DC @ 7V A max	
Display	2-line × 8 character LCD; LED backlighting; 8-digit rate, 8-digit total (resettable)	
Units	User configured: Feet, US gallons, ft ³ , Mil-gal, meters, liters, Mil-ft ³ , m ³ , Mil-liters, acre-feet, oil barrels (42 US gallons), liquid barrel (32.5 US gallons), lb, Kg	
Rate Interval	Second, minute, hour, day. Totalizer exponent: E-2 to E+6 (x ¹ /100 to x 1,000,000)	
Response Time	User selectable: 6...60 seconds	
Output Options	4...20 mA	800 ohms max, internal or external power supply, 12-bit resolution
	Optically Isolated Dual Relay	Independently configured; Form C, 200V AC @ 0.5 A resistive; rate alarm, totalizer pulse, error
	Rate Pulse	500 mV AC Open collector 2500 Hz max, 12-bit resolution, 500 mV AC into 2 K Ohm minimum; 2500 Hz max, 1 A at 100 V max
Multiple Meters	Synchronization provision included—utilized for multiple meter, single pipe/manifold system. Up to four meters may be interconnected, up to 100 feet (30 meters) apart	
Keypad	4-key, tactile	
Ambient Conditions	-40...185° F (-40...85° C); 0...95% relative humidity (non-condensing)	
Approvals	(Std.) General Safety US and Canada. Certified to UL 61010-1 and CSA C22.2 No. 61010-1	
Transducer Type	Compression-mode Ultrasonic; 625 kHz	
Construction	Standard Clamp-On	Type 6* (IP 67) -40...194° F (-40...90° C) CPVC, Ultem®, Nylon, PVC (Cable Jacket), Aluminum (small pipe) *Depth of 1 meter for 30 minutes
	Optional Flexible Armored Conduit	Zinc-plated steel, PVC
Pipe Sizes	Standard Clamp-On Transducers	1 inch (25 mm) and above
	Small Pipe Clamp-On Transducers	0.25...1 inch (6...25 mm)
	Standard Lengths	20, 50 and 100 foot (6.1, 15 and 30 meter), 78 Ohm twinax cable
	Optional Lengths	To 990 feet (297 meters), 75 Ohm RG59 cable

NORTH AMERICAN PIPE SCHEDULES

Steel, Stainless Steel, PVC Pipe, Standard Classes

NPS in.	OD in.	SCH 60		X STG.		SCH 80		SCH 100		SCH 120/140		SCH 180			
		ID in.	Wall in.	ID in.	Wall in.	ID in.	Wall in.	ID in.	Wall in.	ID in.	Wall in.	ID in.	Wall in.		
1	1.315	—	—	0.957	0.179	0.957	0.179	—	—	—	—	0.815	0.250		
1.25	1.660			1.278	0.191	1.278	0.191					1.160	0.250		
1.5	1.900			1.500	0.200	1.500	0.200					1.338	0.281		
2	2.375			1.939	0.218	1.939	0.218					1.687	0.344		
2.5	2.875			2.323	0.276	2.323	0.276					2.125	0.375		
3	3.500			2.900	0.300	2.900	0.300					2.624	0.438		
3.5	4.000	—	—	3.364	0.318	3.364	0.318	—	—	—	—	—			
4	4.500			3.826	0.337	3.826	0.337					3.624	0.438	3.438	0.531
5	5.563			4.813	0.375	4.813	0.375					4.563	0.500	4.313	0.625
6	6.625			5.761	0.432	5.761	0.432					5.501	0.562	5.187	0.719
8	8.625	7.813	0.406	7.625	0.500	7.625	0.500	7.437	0.594	7.178	0.719	6.183	1.221		
10	10.75	9.750	0.500	9.75	0.500	9.562	0.594	9.312	0.719	9.062	0.844	8.500	1.125		
12	12.75	11.626	0.562	11.75	0.500	11.37	0.690	11.06	0.845	10.75	1.000	10.12	1.315		
14	14.00	12.814	0.593	13.00	0.500	12.50	0.750	12.31	0.845	11.81	1.095	11.18	1.410		
16	16.00	14.688	0.656	15.00	0.500	14.31	0.845	13.93	1.035	13.56	1.220	12.81	1.595		
18	18.00	16.564	0.718	17.00	0.500	16.12	0.940	15.68	1.160	15.25	1.375	14.43	1.785		
20	20.00	18.376	0.812	19.00	0.500	17.93	1.035	17.43	1.285	17.00	1.500	16.06	1.970		
24	24.00	22.126	0.937	23.00	0.500	21.56	1.220	20.93	1.535	20.93	1.535	19.31	2.345		
30	30.00	—	—	29.00	0.500	—	—	—	—	—	—	—	—		
36	36.00			35.00	0.500										
42	42.00			41.00	0.500										
48	48.00			47.00	0.500										

Table 3: Steel, stainless steel, PVC pipe, standard classes

Steel, Stainless Steel, PVC Pipe, Standard Classes (continued)

NPS in.	OD in.	SCH 5		SCH 10 (Lt Wall)		SCH 20		SCH 30		STD		SCH 40	
		ID in.	Wall in.	ID in.	Wall in.	ID in.	Wall in.	ID in.	Wall in.	ID in.	Wall in.	ID in.	Wall in.
1	1.315	1.185	0.065	1.097	0.109	—	—	—	—	1.049	—	1.049	0.133
1.25	1.660	1.53	0.065	1.442	0.109					1.380		1.380	0.140
1.5	1.900	1.77	0.065	1.682	0.109					1.610		1.610	0.145
2	2.375	2.245	0.065	2.157	0.109					2.067		2.067	0.154
2.5	2.875	2.709	0.083	2.635	0.120					2.469		2.469	0.203
3	3.500	3.334	0.083	3.260	0.120					3.068		3.068	0.216
3.5	4.000	3.834	0.083	3.760	0.120	—	—	—	—	3.548	—	3.548	0.226
4	4.500	4.334	0.083	4.260	0.120					4.026	0.237	4.026	0.237
5	5.563	5.345	0.109	5.295	0.134					5.047	0.258	5.047	0.258
6	6.625	6.407	0.109	6.357	0.134					6.065	0.280	6.065	0.280
8	8.625	8.407	0.109	8.329	0.148	8.125	0.250	8.071	0.277	7.981	0.322	7.981	0.322
10	10.75	10.482	0.134	10.42	0.165	10.25	0.250	10.13	0.310	10.02	0.365	10.02	0.365
12	12.75	12.42	0.165	12.39	0.180	12.25	0.250	12.09	0.330	12.00	0.375	11.938	0.406
14	14.00	—	—	13.50	0.250	13.37	0.315	13.25	0.375	13.25	0.375	13.124	0.438
16	16.00			15.50	0.250	15.37	0.315	15.25	0.375	15.25	0.375	15.000	0.500
18	18.00			17.50	0.250	17.37	0.315	17.12	0.440	17.25	0.375	16.876	0.562
20	20.00			19.50	0.250	19.25	0.375	19.25	0.375	19.25	0.375	18.814	0.593
24	24.00			23.50	0.250	23.25	0.375	23.25	0.375	23.25	0.375	22.626	0.687
30	30.00			29.37	0.315	29.00	0.500	29.00	0.500	29.00	0.500	29.25	0.375
36	36.00	35.37	0.315	35.00	0.500	35.00	0.500	35.00	0.500	35.25	0.375	35.25	0.375
42	42.00	—	—	—	—	—	—	—	—	41.25	0.375	41.25	0.375
48	48.00									47.25	0.375	47.25	0.375

Figure 18: Steel, stainless steel, PVC pipe, standard classes (continued)

Copper Tubing, Copper and Brass Pipe, Aluminum

Nominal Diameter in.	Copper Tubing in.			Copper & Brass Pipe in.	Alum. in.	Nominal Diameter in.	Copper Tubing in.			Copper & Brass Pipe in.	Alum. in.			
	Type						Type							
	K	L	M				K	L	M					
0.5	OD	0.625	0.625	0.625	0.840	—	3-1/2 in.	OD	3.625	3.625	3.625	4.000	—	
	Wall	0.049	0.040	0.028	0.108			Wall	0.120	0.100	0.083	0.250		
	ID	0.527	0.545	0.569	0.625			ID	3.385	3.425	3.459	3.500		
0.6250	OD	0.750	0.750	0.750	—	—	4 in.	OD	4.125	4.125	4.125	4.500	4.000	
	Wall	0.049	0.042	0.030				Wall	0.134	0.110	0.095	0.095	0.250	
	ID	0.652	0.666	0.690				ID	3.857	3.905	3.935	3.935	4.000	
0.75	OD	0.875	0.875	0.875	1.050	—	4-1/2 in.	OD	—	—	—	—	5.000	
	Wall	0.065	0.045	0.032	0.114			0.250						
	ID	0.745	0.785	0.811	0.822			4.500						
1	OD	1.125	1.125	1.125	1.315	—	5 in.	OD	5.125	5.125	5.125	5.563	5.000	
	Wall	0.065	0.050	0.035	0.127			Wall	0.160	0.125	0.109	0.250	0.063	
	ID	0.995	1.025	1.055	1.062			ID	4.805	4.875	4.907	5.063	4.874	
1.25	OD	1.375	1.375	1.375	1.660	—	6 in.	OD	6.125	6.125	6.125	6.625	6.000	
	Wall	0.065	0.055	0.042	0.146			Wall	0.192	0.140	0.122	0.250	0.063	
	ID	1.245	1.265	1.291	1.368			ID	5.741	5.845	5.881	6.125	5.874	
1.5.	OD	1.625	1.625	1.625	1.900	—	7 in.	OD	—	—	—	—	7.625	7.000
	Wall	0.072	0.060	0.049	0.150			Wall					0.282	0.078
	ID	1.481	1.505	1.527	1.600			ID					7.062	6.844
2	OD	2.125	2.125	2.125	2.375	—	8 in.	OD	8.125	8.125	8.125	8.625	8.000	
	Wall	0.083	0.070	0.058	0.157			Wall	0.271	0.200	0.170	0.313	0.094	
	ID	1.959	1.985	2.009	2.062			ID	7.583	7.725	7.785	8.000	7.812	
2.5	OD	2.625	2.625	2.625	2.875	2.500	10 in.	OD	10.125	10.125	10.125	10.000	—	
	Wall	0.095	0.080	0.065	0.188	0.050		Wall	0.338	0.250	0.212	0.094	—	
	ID	2.435	2.465	2.495	2.500	2.400		ID	9.449	9.625	9.701	9.812	—	
3	OD	3.125	3.125	3.125	3.500	3.000	12 in.	OD	12.125	12.125	12.125	—	—	
	Wall	0.109	0.090	0.072	0.219	0.050		Wall	0.405	0.280	0.254	—	—	
	ID	2.907	2.945	2.981	3.062	2.900		ID	11.315	11.565	11.617	—	—	

Table 4: Copper tubing, copper and brass pipe, aluminum

Cast Iron Pipe, Standard Classes, 3...20 inch

Size in.		Class in.							
		A	B	C	D	E	F	G	H
3	OD	3.80	3.96	3.96	3.96	—	—	—	—
	Wall	0.39	0.42	0.45	0.48				
	ID	3.02	3.12	3.06	3.00				
4	OD	4.80	5.00	5.00	5.00	—	—	—	—
	Wall	0.42	0.45	0.48	0.52				
	ID	3.96	4.10	4.04	3.96				
6	OD	6.90	7.10	7.10	7.10	7.22	7.22	7.38	7.38
	Wall	0.44	0.48	0.51	0.55	0.58	0.61	0.65	0.69
	ID	6.02	6.14	6.08	6.00	6.06	6.00	6.08	6.00
8	OD	9.05	9.05	9.30	9.30	9.42	9.42	9.60	9.60
	Wall	0.46	0.51	0.56	0.60	0.66	0.66	0.75	0.80
	ID	8.13	8.03	8.18	8.10	8.10	8.10	8.10	8.00
10	OD	11.10	11.10	11.40	11.40	11.60	11.60	11.84	11.84
	Wall	0.50	0.57	0.62	0.68	0.74	0.80	0.86	0.92
	ID	10.10	9.96	10.16	10.04	10.12	10.00	10.12	10.00
12	OD	13.20	13.20	13.50	13.50	13.78	13.78	14.08	14.08
	Wall	0.54	0.62	0.68	0.75	0.82	0.89	0.97	1.04
	ID	12.12	11.96	12.14	12.00	12.14	12.00	12.14	12.00
14	OD	15.30	15.30	15.65	15.65	15.98	15.98	16.32	16.32
	Wall	0.57	0.66	0.74	0.82	0.90	0.99	1.07	1.16
	ID	14.16	13.98	14.17	14.01	14.18	14.00	14.18	14.00
16	OD	17.40	17.40	17.80	17.80	18.16	18.16	18.54	18.54
	Wall	0.60	0.70	0.80	0.89	0.98	1.08	1.18	1.27
	ID	16.20	16.00	16.20	16.02	16.20	16.00	16.18	16.00
18	OD	19.50	19.50	19.92	19.92	20.34	20.34	20.78	20.78
	Wall	0.64	0.75	0.87	0.96	1.07	1.17	1.28	1.39
	ID	18.22	18.00	18.18	18.00	18.20	18.00	18.22	18.00
20	OD	21.60	21.60	22.06	22.06	22.54	22.54	23.02	23.02
	Wall	0.67	0.80	0.92	1.03	1.15	1.27	1.39	1.51
	ID	20.26	20.00	20.22	20.00	20.24	20.00	20.24	20.00

Table 5: Cast iron pipe, standard classes, 3...20 inch

Cast Iron Pipe, Standard Classes, 24...84 inch

Size in.		Class in.							
		A	B	C	D	E	F	G	H
24	OD	25.80	25.80	26.32	26.32	26.90	26.90	27.76	27.76
	Wall	0.76	0.98	1.05	1.16	1.31	1.45	1.75	1.88
	ID	24.28	24.02	24.22	24.00	24.28	24.00	24.26	24.00
30	OD	31.74	32.00	32.40	32.74	33.10	33.46	—	
	Wall	0.88	1.03	1.20	1.37	1.55	1.73		
	ID	29.98	29.94	30.00	30.00	30.00	30.00		
36	OD	37.96	38.30	38.70	39.16	39.60	40.04	—	
	Wall	0.99	1.15	1.36	1.58	1.80	2.02		
	ID	35.98	36.00	35.98	36.00	36.00	36.00		
42	OD	44.20	44.50	45.10	45.58	—			
	Wall	1.10	1.28	1.54	1.78				
	ID	42.00	41.94	42.02	42.02				
48	OD	50.55	50.80	51.40	51.98	—			
	Wall	1.26	1.42	1.71	1.99				
	ID	47.98	47.96	47.98	48.00				
54	OD	56.66	57.10	57.80	58.40	—			
	Wall	1.35	1.55	1.90	2.23				
	ID	53.96	54.00	54.00	53.94				
60	OD	62.80	63.40	64.20	64.28	—			
	Wall	1.39	1.67	2.00	2.38				
	ID	60.02	60.06	60.20	60.06				
72	OD	75.34	76.00	76.88	—				
	Wall	1.62	1.95	2.39					
	ID	72.10	72.10	72.10					
84	OD	87.54	88.54	—					
	Wall	1.72	2.22						
	ID	84.10	84.10						

Table 6: Cast iron pipe, standard classes, 24...84 inch

PART NUMBER CONSTRUCTION

DDFX Digital Doppler Ultrasonic Flow Transmitter

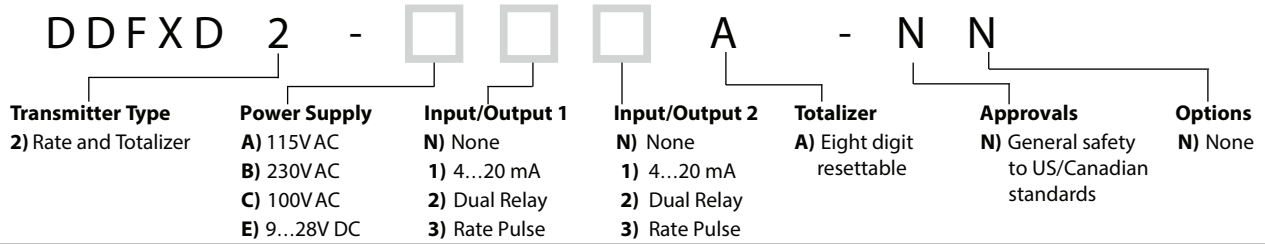

DT9 Doppler Ultrasonic Transducer Set

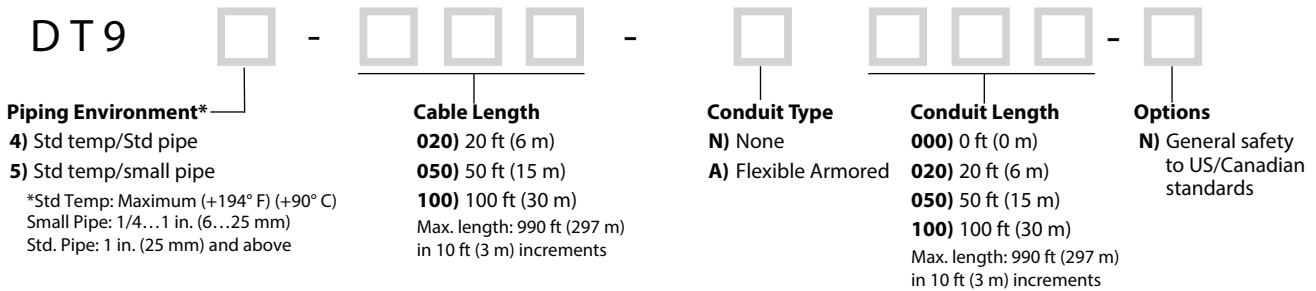

NOTE: All DT9 transducers include acoustic couplant. DT94 includes four (4) 36 in. (890 mm) mounting straps.

DP7 Insertion Doppler Ultrasonic Probes

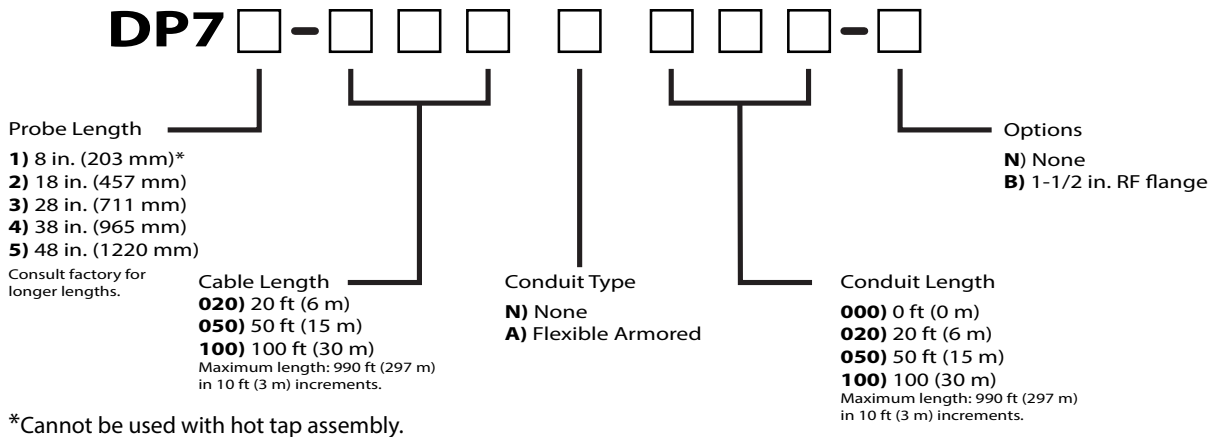

*Cannot be used with hot tap assembly.

NOTE: All DP7 probes include a seal fitting for mounting in 1-1/2 in. NPT ports. Isolation valve kits are available for hot-tapped applications.

INTENTIONAL BLANK PAGE

Control. Manage. Optimize.

Dynasonics is a registered trademark of Badger Meter, Inc. Other trademarks appearing in this document are the property of their respective entities. Due to continuous research, product improvements and enhancements, Badger Meter reserves the right to change product or system specifications without notice, except to the extent an outstanding contractual obligation exists. © 2019 Badger Meter, Inc. All rights reserved.

www.badgermeter.com

The Americas | Badger Meter | 4545 West Brown Deer Rd | PO Box 245036 | Milwaukee, WI 53224-9536 | 800-876-3837 | 414-355-0400
México | Badger Meter de las Americas, S.A. de C.V. | Pedro Luis Ogazón N°32 | Esq. Angelina N°24 | Colonia Guadalupe Inn | CP 01050 | México, DF | México | +52-55-5662-0882
Europe, Eastern Europe Branch Office (for Poland, Latvia, Lithuania, Estonia, Ukraine, Belarus) | Badger Meter Europe | ul. Korfantego 6 | 44-193 Knurów | Poland | +48-32-236-8787
Europe, Middle East and Africa | Badger Meter Europa GmbH | Nurtinger Str 76 | 72639 Neuffen | Germany | +49-7025-9208-0
Europe, Middle East Branch Office | Badger Meter Europe | PO Box 341442 | Dubai Silicon Oasis, Head Quarter Building, Wing C, Office #C209 | Dubai / UAE | +971-4-371 2503
Slovakia | Badger Meter Slovakia s.r.o. | Racianska 109/B | 831 02 Bratislava, Slovakia | +421-2-44 63 83 01
Asia Pacific | Badger Meter | 80 Marine Parade Rd | 19-07 Parkway Parade | Singapore 449269 | +65-63464836
Switzerland | Badger Meter Swiss AG | Mittelholzerstrasse 8 | 3006 Bern | Switzerland | +41-31-932 01 11