

## **APPENDIX B**

# **Fabricating and Installing Rollover Safety Equipment**

## Rollover Protection Safety Equipment

The Office of Vehicle Safety Compliance requires installation of rollover protection safety equipment in each test vehicle before performing J-Turn maneuver tests. The following guidance is provided to assist in fabricating and installing the safety equipment.

### A. Outriggers

Low inertia outriggers designed to minimize roll and yaw inertias were developed for testing vehicles during NHTSA's research phase prior to issuance of the final rule. The outrigger system weighs approximately 1500 lb. When deployed, the outriggers span approximately 270 inches across from wheel to wheel. For testing truck tractors, the outriggers are mounted to the control trailer. Further information and detailed specifications of the outriggers are contained in DOT HS 811 289 (see attached).

**Figure B.1. Outriggers**





## B. Anti-Jackknife Safety System

Each truck tractor and control trailer have an anti-jackknife support system installed. The supports for the truck tractor were incorporated into the design of the roll bar. For the control trailer, supports were fabricated at the bulk head and welded on to the frame. The tractor supports are shown in the picture on the left and the supports for the trailer are shown in the picture on the right.

**Figure B.2. Anti-jackknife mounts on tractor and trailer**



One inch independent wire rope core cables constructed from extra improved plow steel were used to limit the articulation angle and prevent a jack-knife. The cables were attached in an "X" configuration to the supports on the tractor and trailer. To accommodate the geometry differences between the various tractor-trailer combinations, different cable lengths ranging from 50 to 72 inches were used.

**Figure B.3. Anti-jackknife cables**



The cable length was selected to allow articulation angles between 30 and 45 degrees. Using a dial protractor, the angle between the trailer and the tractor frame was measured. At the 45 degree point, the distance between the opposite tractor and trailer jack-knife support was measured. The final measurement was matched to the closest cable length.

**Figure B.4. Cable length determination**



NOTE: - Fifth wheel anti-jackknife devices may also be used. These devices are mounted to the tractor's fifth wheel and restrict rotation of the trailer about the kingpin.

### **C. Truck Tractor Roll Bar**

The purpose of the external roll bar is to protect the driver in the event that the vehicle rolls over during the J-Turn maneuver test runs. The roll bar was mounted to the tractor's frame just behind the cab and its outer edge extended slightly beyond or at the outer perimeter of the tractor's cab body. Each roll bar was constructed from six inch diameter quarter inch thick steel round tubing and weighed approximately, 1500 pounds.

**Figure B.5. Example of a truck tractor roll bar**

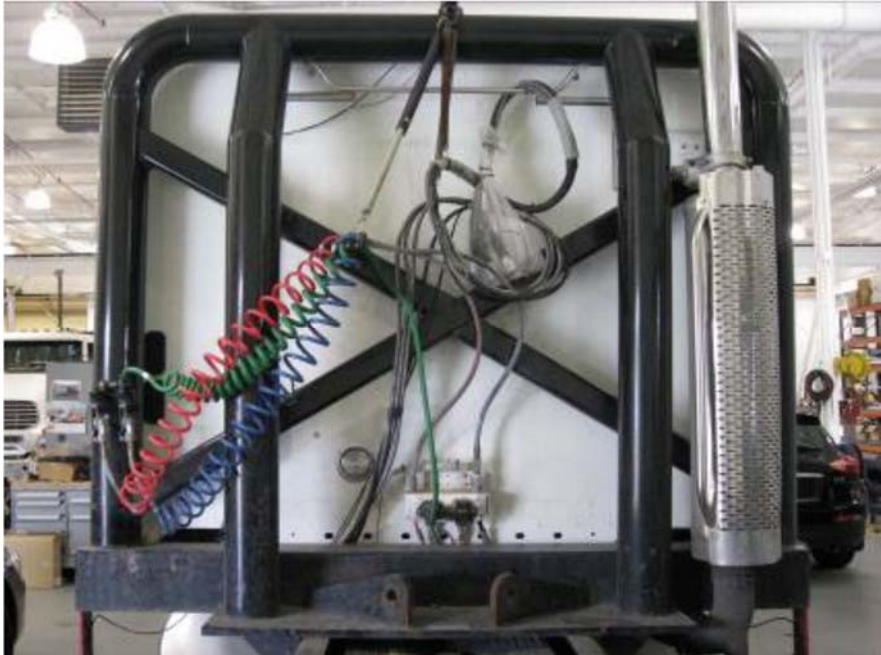

## Previously Answered Questions Regarding Outrigger Fabrication:

Question #1: I'm having a hard time understanding the assembly of the Height Adjust Round Pin and the Pin Retainer. In all of the completed photographs, it appears there is a bolt that passes through the lower tab (circled in green) instead of the Round Pin. However, in all of the CAD pictures, it shows the Pin Retainer (circled in green) and Round Pin. Are the Height Adjust Round Pin and Pin Retainer actually used?

Answer #1: Yes, pins and retainers are used... they replace the bolts, because the bolts were seizing up within the helicoids and were causing major problems for outrigger height adjustment.

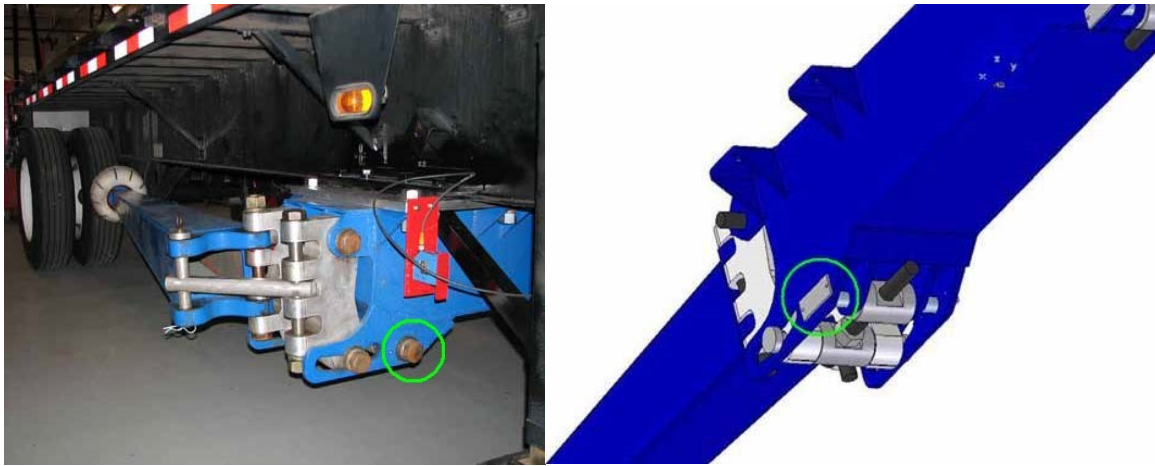

Question #2: Are there any drawings for the 2 components used for locking the outriggers in place during transport? I circled them in red and green. I'm sure we can figure out how to make them on our own but if a drawing exists, then it would make it easier.



Answer #2: No drawings, They are custom fit, and simple to make.

Question #3: The bushings that were specified for the Height Adjustment Round:  
[http://daemar.com/bushing\\_bearings\\_19.html](http://daemar.com/bushing_bearings_19.html)

The link is no longer valid. The company is still in business, but the site has changed. Do you recall what type of bushings they were? Were they plastic or powdered metal sleeve? The company may no longer carry the type / size that were originally specified.

Answer #3:

- 24THX24 - DMR Dry slide Bushings for 1.5" shaft - 1.5 inches long
- 24THX32 - - DMR Dry slide Bushings for 1.5" shaft - 2.0" inches long

[http://daemar.com/bushings\\_dryslide\\_thx\\_136.html/](http://daemar.com/bushings_dryslide_thx_136.html/)

Question #4: Why did you list 2 different lengths of bushings? I only see bushings for the Height Adjustment Round pieces, which require 2 bushings per component.

Answer #4: We put them in the hinges with hole size = 1.669".

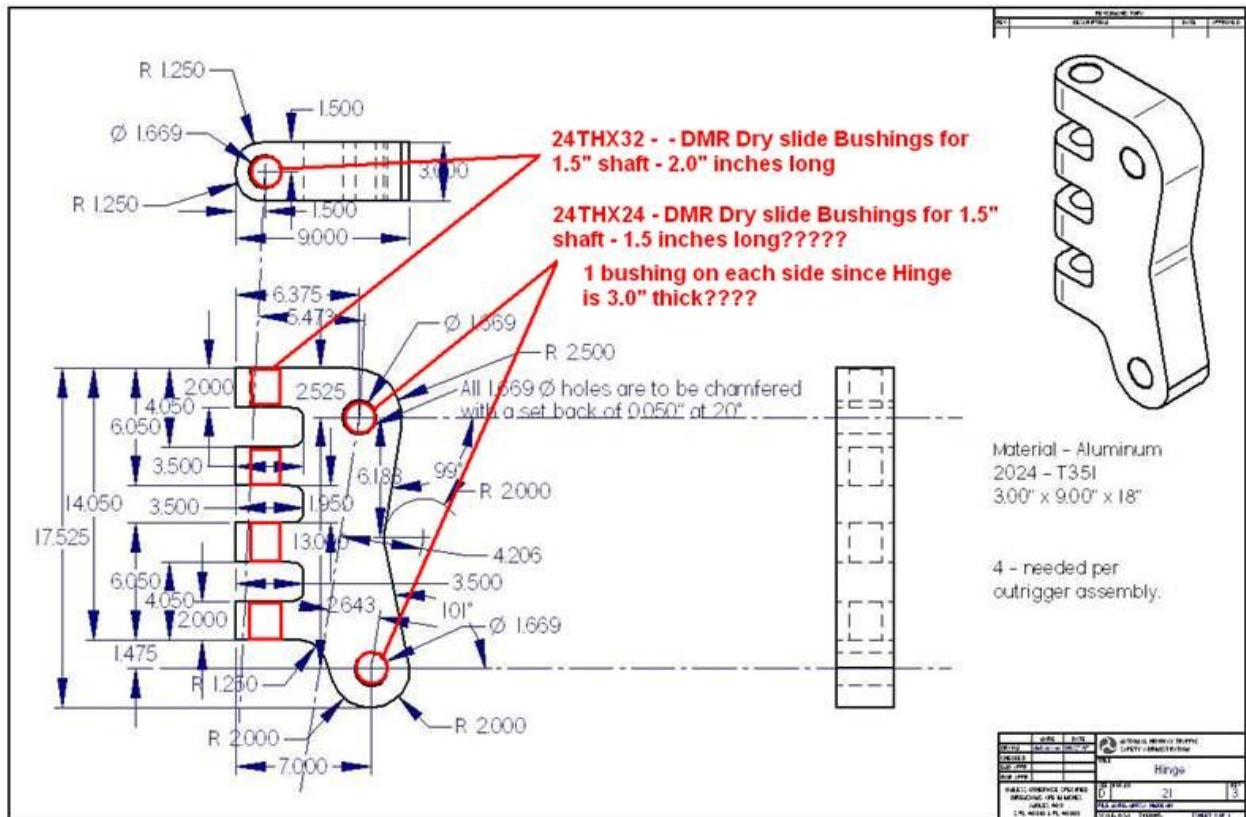







U.S. Department  
of Transportation  
**National Highway  
Traffic Safety  
Administration**



DOT HS 811 289

April 2010

# **National Highway Traffic Safety Administration's Class 8 Tractor/Trailer Safety Outriggers**

## **DISCLAIMER**

This publication is distributed by the U.S. Department of Transportation, National Highway Traffic Safety Administration, in the interest of information exchange. The opinions, findings, and conclusions expressed in this publication are those of the author(s) and not necessarily those of the Department of Transportation or the National Highway Traffic Safety Administration. The United

States Government assumes no liability for its contents or use thereof. If trade or manufacturers' names or products are mentioned, it is because they are considered essential to the object of the publication and should not be construed as an endorsement. The United States Government does not endorse products or manufacturers.



## TECHNICAL REPORT DOCUMENTATION PAGE

1. Report No. <b>DOT HS 811 289</b>	2. Government Accession No.	3. Recipient's Catalog No.	
4. Title and Subtitle <b>National Highway Traffic Safety Administration's Class 8 Tractor\Trailer Safety Outrigger</b>		5. Report Date <b>April 2010</b>	
		6. Performing Organization Code <b>NHTSA/NVS-312</b>	
7. Author(s) <b>Devin H. Elsasser, NHTSA</b>		8. Performing Organization Report No.	
9. Performing Organization Name and Address <b>National Highway Traffic Safety Administration Vehicle Research and Test Center P.O. Box 37 East Liberty, OH 43319</b>		10. Work Unit No. (TRAIS)	
		11. Contract or Grant No.	
12. Sponsoring Agency Name and Address <b>National Highway Traffic Safety Administration 1200 New Jersey Avenue, SE Washington, D.C. 20590</b>		13. Type of Report and Period Covered <b>Draft Report</b>	
		14. Sponsoring Agency Code	
15. Supplementary Notes			
16. Abstract  Recent advances in active safety systems by Original Equipment Manufacturer's (OEM) of class 8 6x4 tractors have led to increases in dynamic field testing at NHTSA. This testing requires safety outriggers to be installed on test vehicles to prevent injury to test drivers and the destruction of instrumentation from rollover type scenarios. Existing safety outriggers were adaptations from a previous design for short trailers. For routine daily testing the existing equipment was found to be cumbersome and out-of-date. Hence, a new set of safety outriggers was designed and fabricated to help facilitate testing needs. This document provides information regarding the research, design and manufacturing of these new replacement outriggers for others desiring to replicate them.			
17. Key Words <b>Electronic Stability Control, ESC, Roll Stability Control, RSC, Dynamic Testing, Test Maneuvers, Rollover, Handling, Lateral Stability, Rollover Mitigation, Class 8 Truck Testing, Class 8 Tractor Testing, Yaw Stability, Outriggers</b>		18. Distribution Statement <b>Document is available to the public from the National Technical Information Service <a href="http://www.ntis.gov">www.ntis.gov</a></b>	
19. Security Classif. (of this report) <b>Unclassified</b>	20. Security Classif. (of this page) <b>Unclassified</b>	21. No. of Pages <b>104</b>	22. Price

**Form DOT F 1700.7 (8-72)**

Reproduction of completed page authorized



## CONVERSION FACTORS

Approximate Conversions to Metric Measures					Approximate Conversions to English Measures				
Symbol	When You Know	Multiply by	To Find	Symbol	Symbol	When You Know	Multiply by	To Find	Symbol
<u>LENGTH</u>					<u>LENGTH</u>				
in	inches	25.4	millimeters	mm	mm	millimeters	0.04	inches	in
	inches	2.54	centimeters	cm		inches		in	centimeters
	centimeters	1.61	miles	mi		feet		feet	ft
	miles	1.61	kilometers	km		miles		miles	mi
	square inches	6.45	square centimeters	cm <sup>2</sup>		square feet		square feet	ft <sup>2</sup>
	square feet	0.09	square meters	m <sup>2</sup>		square miles		square miles	mi <sup>2</sup>
	square meters	2.59	square kilometers	km <sup>2</sup>					
<u>MASS (weight)</u>					<u>AREA</u>				
oz	ounces	28.35	grams	g	cm <sup>2</sup>	square centimeters	0.16	square inches	in <sup>2</sup>
lb	pounds	0.45	kilograms	kg	m <sup>2</sup>	square meters	10.76	square feet	ft <sup>2</sup>
					km <sup>2</sup>	square kilometers	0.39	square miles	mi <sup>2</sup>
<u>PRESSURE</u>					<u>MASS (weight)</u>				
			psi	pounds per inch <sup>2</sup>	g	grams	0.035	ounces	oz
0.07	bar	bar	psi	pounds per inch <sup>2</sup>	kg	kilograms	2.2	pounds	lb
6.89	kilopascals	kPa							
<u>VELOCITY</u>					<u>PRESSURE</u>				
					bar	bar	14.50	pounds per inch <sup>2</sup>	psi
mph	miles per hour	1.61	kilometers per hour	km/h	kPa	kilopascals	0.145	pounds per inch <sup>2</sup>	psi
<u>ACCELERATION</u>					<u>VELOCITY</u>				
ft/s <sup>2</sup>	feet per second <sup>2</sup>	0.30	meters per second <sup>2</sup>	m/s <sup>2</sup>	km/h	kilometers per hour	0.62	miles per hour	mph
<u>TEMPERATURE (exact)</u>					<u>ACCELERATION</u>				
°F	Fahrenheit	5/9[(Fahrenheit) - 32°C]	Celsius	°C	m/s <sup>2</sup>	meters per second <sup>2</sup>	3.28	feet per second <sup>2</sup>	ft/s <sup>2</sup>
<u>TEMPERATURE (exact)</u>					<u>TEMPERATURE (exact)</u>				
					C	Celsius	9/5 (Celsius) + 32	Fahrenheit	F

**NOTE REGARDING COMPLIANCE WITH  
AMERICANS WITH DISABILITIES ACT SECTION  
508**

For the convenience of visually impaired readers of this report using text-to-speech software, additional descriptive text has been provided for graphical images contained in this report to satisfy Section 508 of the Americans With Disabilities Act (ADA).



**TABLE OF CONTENTS**

**CONVERSION FACTORS ..... ii**

**ii**

**List of Tables ..... vii**

**vii List of Figures**

**..... viii**

**ACKNOWLEDGEMENTS ..... xiii**

**xiii**

**1.0 INTRODUCTION..... 1**

1.1 Objectives for New Outriggers ..... 1

**2.0 PREVIOUS NHTSA CLASS 8 OUTRIGGERS ..... 2**

**2**

2.1 Previous Outrigger – Installation ..... 2

2.2 Previous Outrigger – Physical Characteristics ..... 3

2.3 Previous Outrigger – Load Testing ..... 3

2.3.1 Tractor/Trailer ..... 3

2.3.2 Test Maneuvers ..... 4

2.3.3 Test Results ..... 4

**3.0 NEW NHTSA CLASS 8 OUTRIGGERS ..... 7**

**7**

3.1 Design Specifications..... 8

3.2 Material Selection ..... 8

3.3 Skid Plates and Wheel Considerations ..... 9

3.4 Mounting Considerations ..... 11

3.5 Determining Outrigger Width ..... 11

3.6 Structural Design ..... 12

3.6.1 Height Adjustment Round ..... 14

3.6.2 Outboard Beam ..... 15

3.6.3 Inboard Beam ..... 16

3.6.4 Hinge ..... 16

3.6.5 Wheel ..... 17

3.6.6 Retainer Cap..... 18

3.7 New Outriggers Physical Properties ..... 19

<b>4.0 MANUFACTURING .....</b>	
<b>21 4.1 Outboard Beam – Manufacturing .....</b>	
21	
4.2 Inboard Beam – Manufacturing .....	25
4.3 Final Assembly – Manufacturing.....	36
<b>5.0 NHTSA’s EXPERIENCE WITH INSTALLATION and VALIDATION .....</b>	
<b>40</b>	
5.1 Flatbeds and Box Vans .....	40
5.2 Outrigger and Outrigger Mount Static Load Testing .....	42
5.3 Wheel Height Adjustment and Initial Setting .....	43
5.4 Observations From Initial Dynamic Evaluation .....	43

**REFERENCES .....**

**45 APPENDIX**

**..... 46**

Outboard Beam Part Drawings ..... 46  
Outboard Beam Assembly Drawings..... 54  
Inboard Beam Part Drawings ..... 58  
Inboard Beam Assembly Drawings – See Section 4.2 ..... 72  
Hinge Drawing .....  
72 Height Adjustment Round Drawings .....  
73 Wheel Retainer Drawing.....  
75 HDPE Plastic Outrigger Wheel Drawing .....  
76 Pin Retainer Drawing .....  
77 Height Adjustment Round Pin Drawing .....  
78 Free Body Diagram .....  
79 Fastener List .....  
80 Load Cell Information.....  
81 Material Information .....  
82 Welding A514 Steel Information (Internet) .....  
83  
List of Suppliers Used To Fabricate Outriggers ..... 86

**List of Tables**

Table 2.1: Table presents estimated weight and inertia of UMTRI HT Outriggers  
(Tractor/Trailer not included in estimate). ..... 3  
Table 2.2: Table presents measured forces for all instances significant outrigger contact  
were observed. .... 4  
Table 3.1 NHTSA and UMTRI Outrigger Specifications ..... 8  
Table 3.2 Wheel and skid plate contributions to vehicle weight and roll inertia. ....  
11 Table 3.3 Table used to select the outrigger width.  
..... 12 Table 3.4 Outrigger FEA estimates of safety  
factor for an input of 11,000 lb vertical load  
to the outrigger’s plastic wheel. .... 14  
Table 3.5 NHTSA class 8 outriggers physical property reductions From UMTRI designed  
outriggers ..... 19  
Table 3.6 Affects from adding safety outriggers to a simulated 42.5 ft. tanker trailer. ....  
20 Table 5.1: Table of first 14 observed outrigger contact observations with a tractor/trailer  
combination loaded to 80k lbs (axle loading front to rear was 12k(front),  
34k(drive tandem), 34k(trailer tandem)) with a raised C.G..... 44

## List of Figures

<b>Figure 2.1:</b> UMTRI trailer centrally mounted outriggers. Outrigger height is controlled with 3 large set screws indicated in the figure above. ....	2
<b>Figure 2.2:</b> Test data results from the Double Lane Change maneuver at approximately 50 mph. Data represents largest loads observed during outrigger testing. ....	5
<b>Figure 2.3:</b> Plot shows the relationship of roll rate versus measured outrigger force for the tractor/trailer loaded to 80k (axle loading front to rear was 12k(front), 34k(drive tandem), 34k(trailer tandem)) with a raised C.G.....	6
<b>Figure 3.1:</b> Plot shows the relationship of roll rate versus measured outrigger force for the tractor/trailer loaded to 80k (axle loading front to rear was 12k(front), 34k(drive tandem), 34k(trailer tandem)) with a raised C.G.....	7
<b>Figure 3.2:</b> Graph of strength to weight ratio, from left to right the graph is organized in order of increasing strength to weight ratio. Orange bars represent considered materials. Green bars represent materials selected for use in designing the new class 8 outriggers.....	9
<b>Figure 3.3:</b> Photo of the UMTRI outrigger truck wheel\tire axle assembly; it uses a dual wheel with one tire mounted on the outer rim. ....	10
<b>Figure 3.4:</b> Photo shows example of NHTSA’s light vehicle titanium outriggers. Outrigger has hemispherical skid pucks mounted at the ends of the outrigger. The pucks are made of UHMW plastic and they have been found to be a very light and durable especially when compared to castors assemblies. ....	10
<b>Figure 3.5:</b> Left shows a skid plate design considered for the new NHTSA class 8 outriggers. Right shows the HDPE plastic wheel chosen for the new NHTSA class 8 outriggers.....	11
<b>Figure 3.6:</b> Exploded view of new outriggers.....	13
<b>Figure 3.7:</b> Detailed drawing of the Height Adj. Round. There are a total of 4 needed per outrigger assembly. Two are built to the exact details in the drawing above and two are made with a though hole in place of the 1-1/2-12 UNF threaded hole through the middle (a larger figure of the drawing is located in Appendix) and have 1-1/2 - 6 UNC threaded inserts in the ends. ....	14
<b>Figure 3.8:</b> Diagram of the bottom side of the outriggers. In this view the Height Adj. Rounds are shown. The height of the outrigger wheel is adjusted with these parts by turning the threaded bolt which forces the outriggers to pivot about the upper joint on the hinges. <i>NOTE: To adjust the outrigger height all fasteners should be loosened. Tighten and reset slider bolts to 500 – 800 ft/lbs when finished.</i> .....	15
<b>Figure 3.9:</b> FEA of Outboard Beam.....	16
<b>Figure 3.10:</b> Left is an example of an early dimensional model which turned out to be an unacceptable design for weight and safety factor reasons. Right shows the final solution that allows the adjustability desired for the new outriggers without	

sacrificing weight. ....

17 **Figure 3.11:** FEA example of HDPE

plastic outrigger wheel. Wheel is constrained

at the hole and an 11,000 lb magnitude load is

applied at a 30 degree angle to the

vertical plane. High stresses are observed around the impact and are distributed very low levels at the hole for the axle shaft. .... 18

**Figure 3.12:** Detailed Drawing of the new outrigger wheel Retainer Cap. ....

19 **Figure 4.1:** Assembly details of the Outboard Beam of the new NHTSA class 8 outriggers.

Labels on the parts are used in subsequent Inboard Beam assembly

drawings. ....

22

**Figure 4.2:** Pictures of the fabrication of the outboard beam. Clamps and 90° angle iron pieces are used to jig the plates that form the tapered beam (outer edges are aligned and tacked into place). All outside seams were continuously welded.

Inner seams were welded according to what the welder could reach. ....

22 **Figure 4.3:** Left: Base Plate is added to the end. Middle: Base plate is welded to the Outboard Beam in the locations that the Hinge Brackets will overlap. Right: Hinge Brackets are being jugged up to weld. The bolts shown in the photo were

removed and a aluminum jig was inserted into the holes to assure alignment, see Figure 4.4 (Middle). .... 23

**Figure 4.4:** Left: clamping and jugging of Hinge Brackets. Middle: aluminum jig used to assure alignment. Welding was performed with jig in the holes. Right: finished Hinge Brackets with shoulder bolts in. The bolts should easily slide

through holes when finished. .... 23

**Figure 4.5:** Left: End Plate and Axle Shaft are welded together. All inside and outside seams were welded. Middle: the weld bead and face of end plate are turned on a lathe to create chamfer and remove any rough edges that would snag HDPE Plastic Wheel. Right: finished Axle Shaft and End Plate are ready for attachment

to Outboard Beam. .... 24

**Figure 4.6:** Left: End Plate and Axle Shaft are jugged into place for final attachment to the Outboard Beam of the new outriggers. Right: All seams are welded, multiple weld passes

maybe necessary. Outboard Beam is complete.....	24	<b>Figure 4.7:</b>
Finished welded and painted Outboard Beam.....	24	<b>Figure 4.8:</b>
Exploded view of the Inboard Beam. Labels on the parts are used in subsequent Inboard Beam assembly drawings. ....	25	
<b>Figure 4.9:</b> NHTSA began assembly of the Inboard Beam by tack welding one of the Side Plates to the Bottom Plate. A welding table (flat plate), clamps and straight edges were used to reduce warp from welding. ....	26	
<b>Figure 4.10:</b> Second and third steps NHTSA used in the assembly process. Continue to use welding table, clamps and straight edges to reduce warp from welding. ....	27	<b>Figure</b>
<b>4.11:</b> Fourth step taken was to add the Top Plate. All pieces were tack welded up to this point. Once the Top Plate was tacked in place all seems (inside and out) that could be reach by the welder were welded. ....	28	
<b>Figure 4.12:</b> Fifth step; tack weld in the Upper Cover Plates on each end. They are centered side to side. ....	29	
<b>Figure 4.13:</b> Sixth step; tack weld in place the Upper Tabs using the Aluminum Hinges and shims as jigs to assure free play tolerances. All seems were welded. ....	30	
<b>Figure 4.14:</b> Seventh step; Tack weld in place the Lower Adjustment Brackets using Hinges, jigs and shims to assure tolerances. Attachment of this part is critical to the ease with which the height adjustment mechanism can be operated. The Aluminum Hinges, Height Adjustment Rounds should all be bolted in to check for interferences. After the check; the Lower Adjustment Brackets were welded in place. ....	31	
<b>Figure 4.15:</b> 8 <sup>th</sup> and 9 <sup>th</sup> steps; attach the Lower Plate and Lower Tabs. ....	32	
<b>Figure 4.16:</b> 10 <sup>th</sup> through 12 <sup>th</sup> steps; Attach the Mid Cover Plates, Lower Cover Plates and Lower Gusset Bars. ....	33	
<b>Figure 4.17:</b> 13 <sup>th</sup> step; attach the Mounting Brackets along the top edge of the Top Plate. ....	34	
<b>Figure 4.18:</b> Left: Small parts needed to assemble the new outriggers. Right: Large plates that are welded together to make up the shell of the Inboard Beam. ....	35	<b>Figure 4.19:</b>
Left: 1 <sup>st</sup> step complete clamps have been removed. Right: 7 <sup>th</sup> step, critical placement of the Lower Adjustment Brackets. Hinges, all thread, and shims are used to jig into place. Consider tack welding on some straps across the brackets to further constrain warping. ....	35	
<b>Figure 4.20:</b> Left: 8 <sup>th</sup> and 9 <sup>th</sup> steps have been completed and jiggling has been removed. Right: 12 <sup>th</sup> step has been completed; cover plates were welded in place. <i>Note:</i> <i>Jigs holding the Lower Adjustment Brackets should be left in when welding is</i> <i>taking place on the Inboard Beam. Free play tolerances were lost when those jigs</i> <i>were removed and welding operations performed. ....</i>	35	
<b>Figure 4.21:</b> Left: 13 <sup>th</sup> step attachment of Mounting Brackets. Right: final Inboard Beam fabrication; the welds were touched up and cleaned to be painted. ....	36	
<b>Figure 4.22:</b> Center: completely assembled new NHTSA outriggers ready to go under a trailer.		

Top Left: picture of the outriggers in transport position. Lower Right: Zorin hydraulic elevating lift cart with payload capacity of 2000lbs and height range of 15.0 - 39.0 inches. It is used to ease the moving and installation of outriggers. .... 36

**Figure 4.23:** Exploded view of the new outriggers. Gives notes on fasteners and lubrication of joints. .... 37

**Figure 4.24:** More notes regarding the bolts and joint free play that can affect the height setting of the outrigger. ....

38 **Figure 4.25:** Fastener tightening and torques settings used by NHTSA. ....

39 **Figure 5.1:** Center: shows the main beam of the new outriggers mounted to a 28ft. flatbed type trailer. The main trailer rails are clamped on the outside and insides Upper Left: Shows the inside flanges of the trailer main rails were clamped and bolted to the outrigger adapter plate. .... 41

**Figure 5.2:** Center: Above shows the main beam mounted to a box van type trailer. The aluminum tubes between the outrigger and the bottom of the trailer were added to help distribute forces from the outrigger striking the test surface. Top Right: Inside view of the box van trailer; shows the clamp downs used to hold the aluminum tubes and outrigger to the bottom of the trailer. .... 41

**Figure 5.3:** Static outrigger and outrigger mount load rating check. Wheel on opposite side is blocked so that both Outboard Beams are evaluated at the same time. The blocks were then removed and a load was reapplied to the outrigger to evaluate the mounts. Setup used an overhead crane and tensile load cell to measure the force applied to the outriggers. .... 42

**Figure 5.4:** Diagram shows details on setting initial outrigger wheel height to between 10-11 inches. .... 43

**Figure 5.5:** Wear after the first observed contact between wheel and test surface. ....

44 **Figure 5.6:** Wear after seven strikes between wheel and test surface. ....

44 **Figure 5.7:** Wear after 14 strikes between wheel and test surface. Diameter change is estimated at ~1/32 inch or less. .... 44

**Figure A.1:** Assembly details of the Outboard Beam of the new NHTSA class 8 outriggers. Labels on the parts are used in subsequent Outboard Beam assembly drawings. .... 46

**Figure A.2:** Draft of Hinge Bracket for the Outboard Beams. Note: Quantity needed is shown in Figure A1, double the quantity to build a complete set of outriggers. .... 47 **Figure A.3:** Draft of Base Plate for the Outboard Beams. Note: Quantity needed is shown in Figure A1,

double the quantity to build a complete set of outriggers. ....	48
<b>Figure A.4:</b> Draft of End Plate for the Outboard Beams. Note: Quantity needed is shown in Figure A1, double the quantity to build a complete set of outriggers. ....	49
<b>Figure A.5:</b> Draft of Axle Tube for the Outboard Beams. Note: Quantity needed is shown in Figure A1, double the quantity to build a complete set of outriggers. ....	50
<b>Figure A.6:</b> Draft of Bottom Plate for the Outboard Beams. Note: Quantity needed is shown in Figure A1, double the quantity to build a complete set of outriggers. ....	51
<b>Figure A.7:</b> Draft of Side Plate for the Outboard Beams. Note: Quantity needed is shown in Figure A1, double the quantity to build a complete set of outriggers. ....	52
<b>Figure A.8:</b> Draft of Top Plate for the Outboard Beams. Note: Quantity needed is shown in Figure A1, double the quantity to build a complete set of outriggers. ....	53
<b>Figure A.9:</b> Side view draft of the Outboard Beam assembly. ....	54
<b>Figure A.10:</b> End view (Hinge Bracket placement) draft of the Outboard Beam assembly. ....	55
<b>Figure A.11:</b> End view (Axle and End Plate placement) draft of the Outboard Beam assembly. ....	56
<b>Figure A.12:</b> Top view draft of the Outboard Beam assembly. ....	57
<b>Figure A.13:</b> Break down draft of the Inboard Beam. ....	58
<b>Figure A.14:</b> Draft of Bottom Plate for the Inboard Beam. ....	59
<b>Figure A.15:</b> Draft of Side Plate for the Inboard Beam. ....	60
<b>Figure A.16:</b> Draft of Top Plate for the Inboard Beam. ....	61
<b>Figure A.17:</b> Draft of Upper Cover Plate for the Inboard Beam. ....	62
<b>Figure A.18:</b> Draft of Support Brace for the Inboard Beam. ....	63
<b>Figure A.19:</b> Draft of Mid Cover Plate for the Inboard Beam. ....	64
<b>Figure A.20:</b> Draft of Lower Cover Plate for the Inboard Beam. ....	65
<b>Figure A.21:</b> Draft of Lower Plate for the Inboard Beam. ....	66
<b>Figure A.22:</b> Draft of Upper Tab for the Inboard Beam. ....	67
<b>Figure A.23:</b> Draft of Lower Adjustment Bracket for the Inboard Beam. ....	68
<b>Figure A.24:</b> Draft of Lower Tab for the Inboard Beam. ....	69
<b>Figure A.25:</b> Draft of Lower Gusset for the Inboard Beam. ....	70
<b>Figure A.26:</b> Draft of Mounting Bracket for the Inboard Beam. ....	71
<b>Figure A.27:</b> Draft of Aluminum Hinge. ....	72
<b>Figure A.28:</b> Draft of Height Adjustment Round with threaded through hole. ....	73
<b>Figure A.29:</b> Draft of Non-Threaded Height Adjustment Round. ....	74
<b>Figure A.30:</b> Draft of Wheel Retainer. ....	75



<b>Figure A.31:</b> Draft of HDPE Plastic Outrigger Wheel. ....	76
<b>Figure A.32:</b> Draft of Pin Retainer used to constrain Threaded Height Adjustment Round. ....	77
<b>Figure A.33:</b> Draft of Height Adjustment Round Pin used to constrain Height Adjustment Round with the threaded through hole. ....	78
<b>Figure A.34:</b> Free-body-diagram showing simplified forces used for FEA analysis. ....	79

## ACKNOWLEDGEMENTS

This work presented in this report would not have been possible without the outstanding support of my research colleagues. At NHTSA, Dr. Riley Garrott, Frank Barickman and Garrick Forkenbrock provided design and project support. Robin Esser and Shannon Reed provided purchasing, contract and administrative support. Contractors at the Transportation Research Center Inc., who contributed significantly to the completion of this work, were Jim Preston, Bill Moffitt, Jared Dowdy, Heath Albrecht, Jason Church, Guogang Xu, Mike Thompson, Don Meddles, Chris Boday, Lyle Heberling, Don Thompson, and Jan Cooper.

Devin H. Elsasser

## **1.0 INTRODUCTION**

Recent safety advances to class 8 vehicles by OEM's have lead to a ramp up in vehicle testing by the National Highway Traffic Safety Administration (NHTSA). Testing Class 8 vehicles at their lateral limits has been found to be dangerous and requires safety equipment to ensure that the driver, the test vehicle and the instrumentation are protected from rollover type scenarios. For protection, current NHTSA dynamic testing requires class 8 test vehicles to be equipped with a racing seat and 4-point safety harness for the driver and a roll bar and outriggers to prevent rollover of the test vehicle. During the initial phases of research and test track evaluation, researchers determined that a new set of safety outriggers would need to be designed and fabricated for research and performance testing purposes. This was concluded for several reasons. First, the current class 8 vehicle outriggers are not foldable and had to be installed and removed everyday that a testing session was scheduled. Estimated testing time lost was 1 hour. Second, those outriggers are considered heavy and affect fully loaded tractor/trailers roll inertia by more than 25 percent. Lastly, their mounting requirements restrict them to trailer applications only. This document discusses the research, design and fabrication of the new outriggers. This document also details NHTSA initial experiences with the modern outriggers and provides detailed drawings and additional information for those interested in replicating the new design.

### **1.1 Objectives for New Outriggers**

The new outriggers were designed around several objectives. They were:

- Keep the test drivers safe.
- Preserve vehicles and instrumentation while performing lateral limit maneuvers.
- Keep weight and inertial affects caused by mounting safety outriggers to test vehicle to a minimum.
- Design the outriggers to fold for transport to and from a test facility.
- Universal mounting.

Outriggers meeting these objectives will be implemented as NHTSA standard test equipment for future lateral limit research of large single and combination vehicles.

## **2.0 PREVIOUS NHTSA CLASS 8 OUTRIGGERS**

NHTSA Heavy Truck Safety Outriggers have been primarily installed on class 8 tractor/semitrailer combination vehicles. These centrally mounted outriggers have been in use since the early 1990's up until a newly designed set of outriggers replaced them in the winter of 2008. The previous outriggers were originally designed for NHTSA by the University Of Michigan Transportation Research Institute (UMTRI) to be used with stability testing of single tractor triple trailer configuration. Each trailer in this configuration was 28 feet in length and the last two trailers were equipped with the centrally mounted safety outriggers. At the completion of those tests, a single set of the outriggers were modified and installed on a 53ft van trailer slated for evaluation. Since

that time, the outriggers have been largely unchanged and have served their purpose well. As NHTSA personnel became familiar with outrigger setup and installation, they learned that several of these tasks were burdensome often shortening the amount of testing time available to the researchers. Also, the installation of safety outriggers was found to have large affects to certain physical characteristics of the trailer.

## 2.1 Previous Outrigger – Installation

Installation of the outrigger was accomplished by custom fabrication of the center portion of the outrigger or by altering the trailer to accept an existing center section. The outriggers were longitudinally centered between the loaded and unloaded center of gravity measurements. Once the center section was mounted the outboard beams could be attached and their height (height meaning the distance between the bottom of the wheel and ground plane) controlled via 3 large set screws shown in Figure 2.1. Typically, VRTC would set the outriggers to a nominal height of 10 inches. This generally allowed approximately  $\pm 8$  degrees of roll angle and 2-6 inches of wheel height at the outer trailer wheels. If outrigger to test surface contact occurred prior to wheel lift then the outrigger height was increased by 1 inch.



**Figure 2.1:** UMTRI trailer centrally mounted outriggers. Outrigger height is controlled with 3 large set screws indicated in the figure above.

## 2.2 Previous Outrigger – Physical Characteristics

As can be seen in Figure 2.1 a significant portion of the mass is placed at the ends of the outriggers. The wheel/tire package alone weighs approximately 226 lbs per outer beam. Each of the outer beam assemblies (including wheel/tire assembly) weigh 750 lbs. Altogether the outriggers weigh approximately 2200 lbs. Being centrally mounted the outriggers have a relatively small effect to the yaw and pitch inertias of the trailer. However, the roll inertia change resulting from outrigger installation is quite substantial. The roll inertia was observed to be increased by 22 percent for an 42.5 ft. tanker at GVWR and 89 percent when that tanker was unloaded. Inertial effects were estimated using solid modeling software. Past experiences have shown that the software to be within  $\pm 1$  percent when estimating weight and  $\pm 5$  percent when estimating inertia.

**Table 2.1:** Table presents estimated weight and inertia of UMTRI HT Outriggers (Tractor/Trailer not included in estimate).

UMTRI HT Outrigger			
Weight (lbs)	Inertial Properties (lb-ft-s <sup>2</sup> )		
	Roll	Pitch	Yaw
2200	3675	96	3743

### 2.3 Previous Outrigger – Load Testing

To learn more about the loads applied to the outriggers during lateral stability testing with class 8 tractors the UMTRI outriggers were instrumented with load cells. While instrumented, experimenters performed 3 maneuvers that have been found to repeatedly produce outrigger contact for a given tractor/trailer configuration and maneuver entrance speed. Data would then be processed and used to evaluate the safety factor of the UMTRI outriggers for the given tractor/trailer configuration and maneuver. Then a new set of outriggers would be designed around the maximum forces observed.

This section provides general descriptions of the tractor/trailer combination, the suite of maneuvers evaluated and the results from the testing.

#### 2.3.1 Tractor/Trailer

The test tractor used was a 2006 Volvo 6x4 (VNL 64T630, Drum Brakes, Bendix ESC) tractor connected to a 2001 Fruehauf 53 foot box trailer (Meritor Wabco 4S/2M ABS). The combination was loaded to 80k lbs (axle loading front to rear was 12k, 34k, 34k) with the trailer’s vertical center of gravity at approximately 81.0 inches as measured from the ground plane.

Both units were instrumented with accelerometers, angular rate sensors, ride height sensors, and GPS. Speed was measured at the lead unit. The outriggers were instrumented with 3 load cells shown in Figure 2.1 which were placed between the height adjustment screws to measure the compression forces resulting from outrigger to test surface contact. More load cell information is located in the appendix. All instrumentation was fed to data acquisition computers located in the tractor. Test data were stored and then post-processed for analysis.

#### 2.3.2 Test Maneuvers

Three maneuvers were performed to apply dynamic testing loads to the outriggers. Those maneuvers are listed below.

1. 150 foot Constant Radius Maneuver
  - a. Test driver increases speed from rest.
  - b. Increase speed until outriggers arrest roll response of the test vehicle.
2. 150 foot J-Turn Maneuver

- a. Test driver approaches radius on a path that is tangent to the radius and is instructed to drop throttle and clutch-in prior to initiating the maneuver.
  - b. Test speed was increased by 2 mph increments from 20 mph until outriggers arrest roll response of the test vehicle.
3. Double Lane Change
- a. Test driver approaches lane change and is instructed to drop throttle and clutch-in prior to initiating the maneuver.
  - b. Test speed was increased by 2 mph increments from 20 mph until outriggers arrest roll response of the test vehicle.

The three test maneuvers were performed in order of perceived severity by the experimenters. Testing began with the constant radius test, then the J-turn and then followed by the double lane change maneuver.

### 2.3.3 Test Results

After completing the test maneuvers the data were post-processed for further analysis. Table 2.2 summarizes the test results showing each tested maneuver that resulted in outrigger-to-test surface contact and their corresponding speeds, forces at the outrigger mount, the calculated forces at the outrigger wheel and the peak observed roll rates of the trailer. From the table; the constant radius test shows the smallest measured forces that were observed with the force at the outrigger wheel ranging from 2347 – 5466 lbs. Measured forces ranged from 4043 – 5004 lbs for the J-turn and 8579 – 10,083 lbs for the double lane change maneuvers.

**Table 2.2:** Table presents measured forces for all instances significant outrigger contact were observed.

Test Maneuver	Speed (mph)	Force at Mount (lbs)	Force At Wheel (lbs)	Peak Roll Rate (deg/sec)
150ft Constant Radius	30.0	15023	2347	6.15
150ft Constant Radius	30.6	17798	2781	6.93
150ft Constant Radius	31.1	34983	5466	8.55
150ft J-Turn	32.6	32024	5004	8.68
150ft J-Turn	32.2	29076	4543	9.57
150ft J-Turn	32.5	25877	4043	9.64
Double Lane Change	49.2	54907	8579	18.9
<b>Double Lane Change</b>	<b>49.5</b>	<b>64529</b>	<b>10083</b>	<b>20.2</b>

From the table, the highest forces were observed with the double lane change maneuver which was tested at higher maneuver entrance speeds and resulted in larger roll rates that threw the large inertias associated with the loaded trailer from side to side. The test data from the double lane change maneuver that is highlighted in bold is shown in Figure 2.2. From left to right, and top to bottom are the time history plots of roll angle of the trailer, the force data measured at the outrigger mount, roll rate of the trailer and the calculated resultant force at the outrigger wheel. These test data were used to develop the load criteria for the new NHTSA Heavy Truck Outriggers.

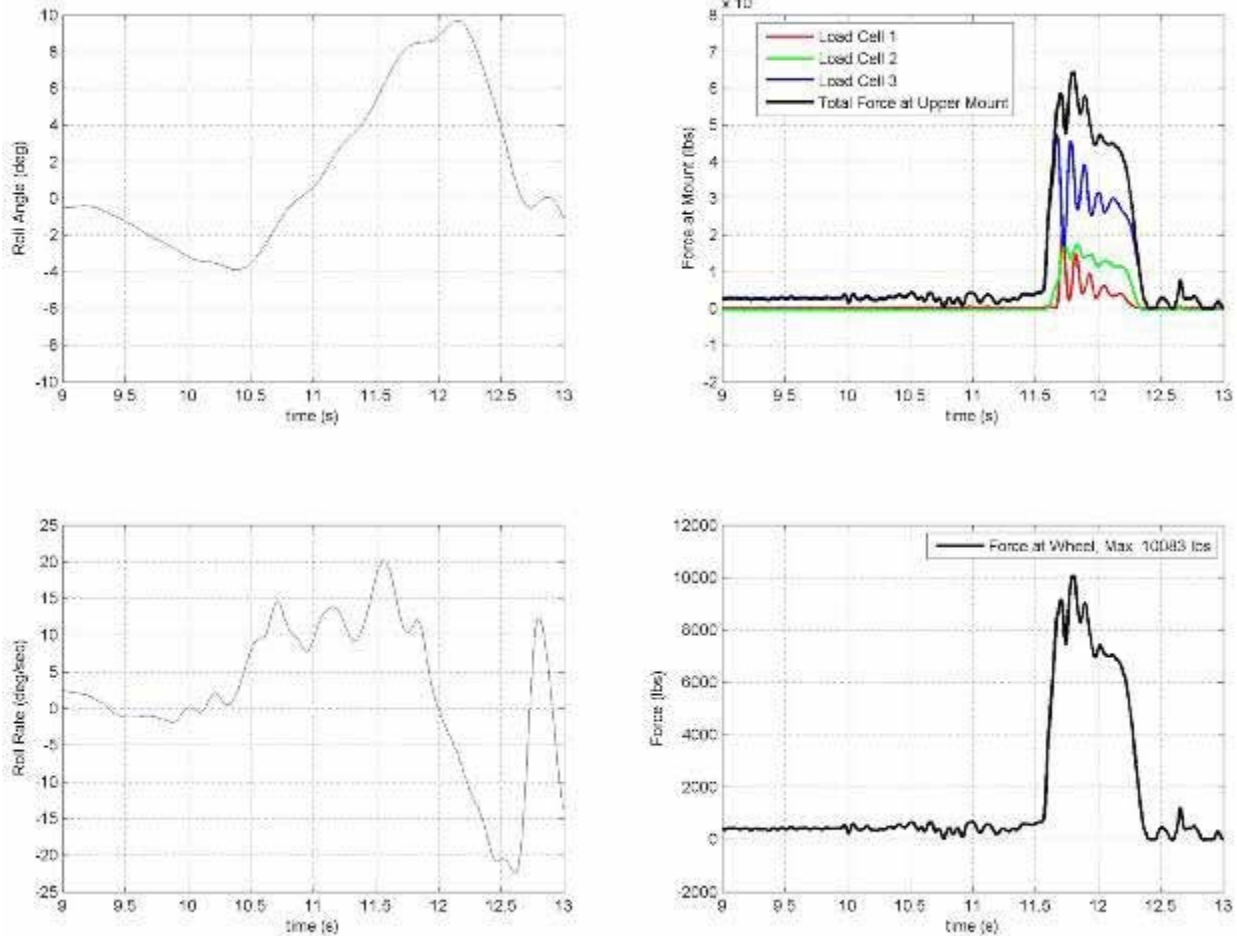
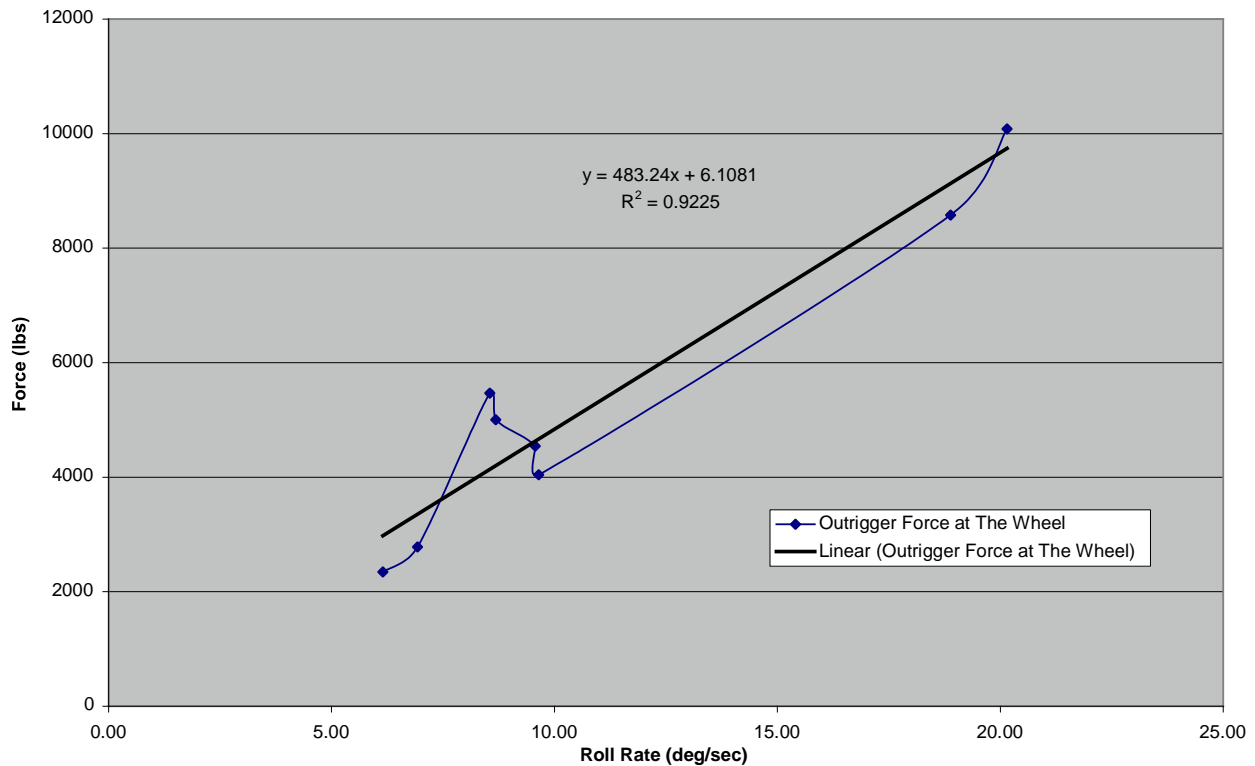

**Figure 2.2:** Test data results from the Double Lane Change maneuver at approximately 50 mph. Data represents largest loads observed during outrigger testing.

To build some load capacity cushion into the design of the new outriggers, the load data in Table 2.2 was compared to the peak roll rate<sup>1</sup> for each of the tests presented. The comparison revealed that as roll rate increases the forces the outrigger must resist also increase. This relationship is shown graphically in Figure 2.3. Researchers found this relationship to be quite linear even though multiple data points represent 3 different maneuvers conducted at different speeds. The equation of the trend line through outrigger force versus roll rate data is also shown in the figure. The equation of that line was then used to extrapolate out to 23 deg/sec (max observed = 20.2 deg/sec). The force calculated at that roll rate is approximately 11,000 lbs which was then used as the design load for the new outrigger development.

Outrigger Load Testing - Force at the Wheel Versus Trailer Roll Rate

<sup>1</sup> Peak roll rate is presented in the final column of the Table 2.2. The table is sorted by increasing roll rate



**Figure 2.3:** Plot shows the relationship of roll rate versus measured outrigger force for the tractor/trailer loaded to 80k (axle loading front to rear was 12k(front), 34k(drive tandem), 34k(trailer tandem)) with a raised C.G.

### 3.0 NEW NHTSA CLASS 8 OUTRIGGERS

The UMTRI outriggers have been used by NHTSA VRTC for more than a decade and they have validated their design and use as safety devices. Through that experience, a few changes to the design were desired. The first was to make them foldable so that they could be driven through a 12 foot garage door or be driven legally<sup>2</sup> down the road. Second was to reduce their weight and roll inertia influences to the vehicle they were mounted on. All the while maintaining the ability to adjust the outrigger height and keep needed maintenance to a minimum. Looking at the desired design changes to the UMTRI outriggers, it became obvious that it would be easier and faster to design and fabricate a new set of outriggers. With that, the load testing was initiated with the UMTRI outriggers being used at the time. Research into previous outrigger designs and discussions with industry was conducted.

Once load testing was complete<sup>3</sup> design of a replacement set of outriggers began. That testing determined the design load, which is based on the relationship between peak roll rate and the normal force on the outrigger wheel. This is shown again in Figure 3.1. It was found by extrapolation - that a 23.0 deg/sec would generate approximately 11,000 lbs of normal force at the outrigger wheel. That load was then used as the load capacity around which the outrigger design began.

<sup>2</sup> Legally refers to overall width of a vehicle which must not exceed 102 inches. Anything over 102 inches needs a special permit.

<sup>3</sup> Load testing of the UMTRI outriggers was discussed in Section 2.3.

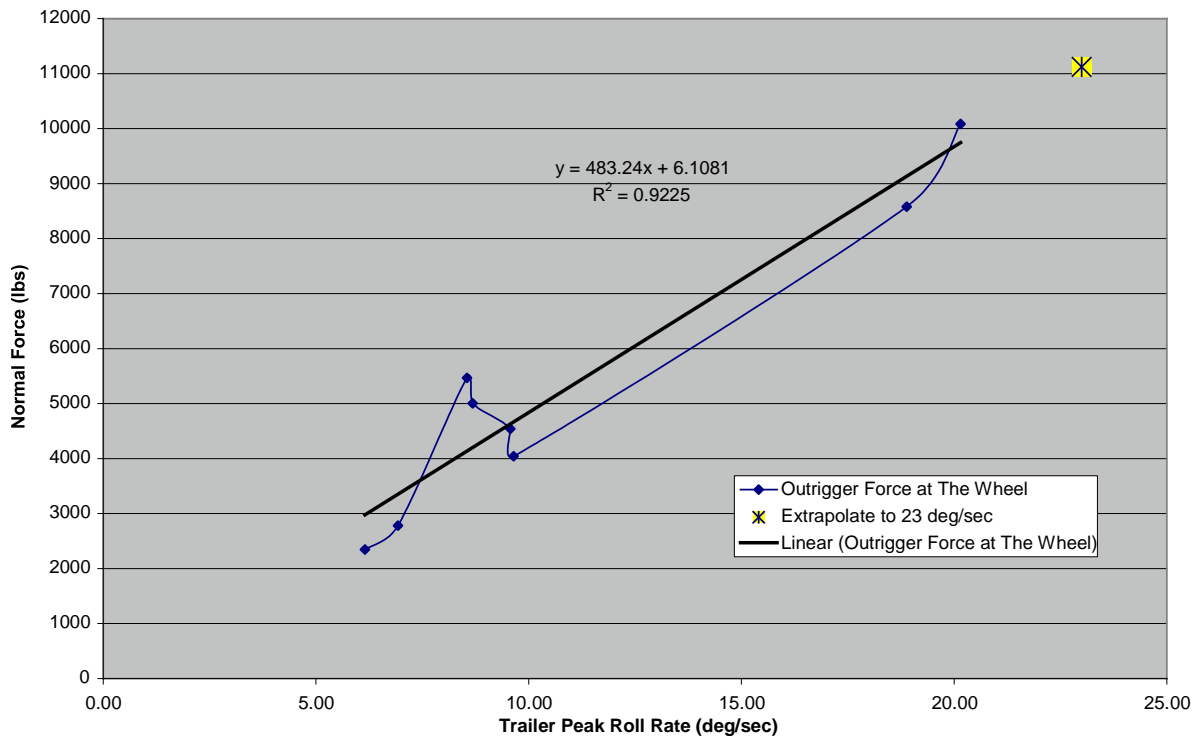

**Figure 3.1:** Plot shows the relationship of roll rate versus measured outrigger force for the tractor/trailer loaded to 80k (axle loading front to rear was 12k(front), 34k(drive tandem), 34k(trailer tandem)) with a raised C.G.

### 3.1 Design Specifications

The design specifications set forth upon determining the design load are shown in Table 3.1. For comparison general specifications of the UMTRI outriggers that were in use at the time are also presented. From left to right, the table shows a design length of 269” which is slightly longer than the UMTRI outriggers. Next it shows the load capacity of each outrigger and then the minimum safety factor associated with that load capacity. It then shows the new design will incorporate foldable outriggers while the UMTRI outriggers are not foldable. Then, both outriggers are shown to be height adjustable. Lastly, the table shows that there was an attempt to make the outriggers universally mountable while the UMTRI outriggers require custom under carriages and mounts to be made for each trailer.

**Table 3.1 NHTSA and UMTRI Outrigger Specifications**

Outrigger	Length (in)	Load Rating (lbs)	Minimum Safety Factor	Foldable	Height Adjustable	Universally Mountable
NHTSA	269	11,000	3	Yes	Yes	Yes
UMTRI	265	N/A	N/A	No	Yes	No



### 3.2 Material Selection

Aluminum, steel, and titanium were considered for design of the new class 8 outriggers. Ultimately, the titanium was ruled out because the costs associated with the material (raw materials, i.e. flat, rounds... would exceed \$35,000/per outrigger). From material research, it was determined that the new outrigger design could take advantage of stronger materials so more weight can be removed from the outrigger design without sacrificing safety factors. Figure 3.2 shows the strength-to-weight ratio of various materials. The materials considered for design but were ruled out are highlighted in orange. Steel ASTM A514<sup>4</sup> and Aluminum 2024-T351 are highlighted in green which denotes they were selected for the design of the new outriggers. They were selected for their strength, availability, and weldability. Since the outriggers would be of considerable size (beams longer than 100 inches) heat treating the final product was ruled out which in-turn ruled out the 4130 water quenched steel (requires heat treating) among others. A514 was selected over ASTM A36 because it met all other requirements and had a better strength to weight ratio. A few parts were not made of A514 steel because it is only available in flat and plate stock. The round steel tubing used for design was pipe (ASTM A53 Steel) and square structural tubing was graded ASTM A500.

Figure 1: Various Materials Sorted by Strength to Weight Ratio

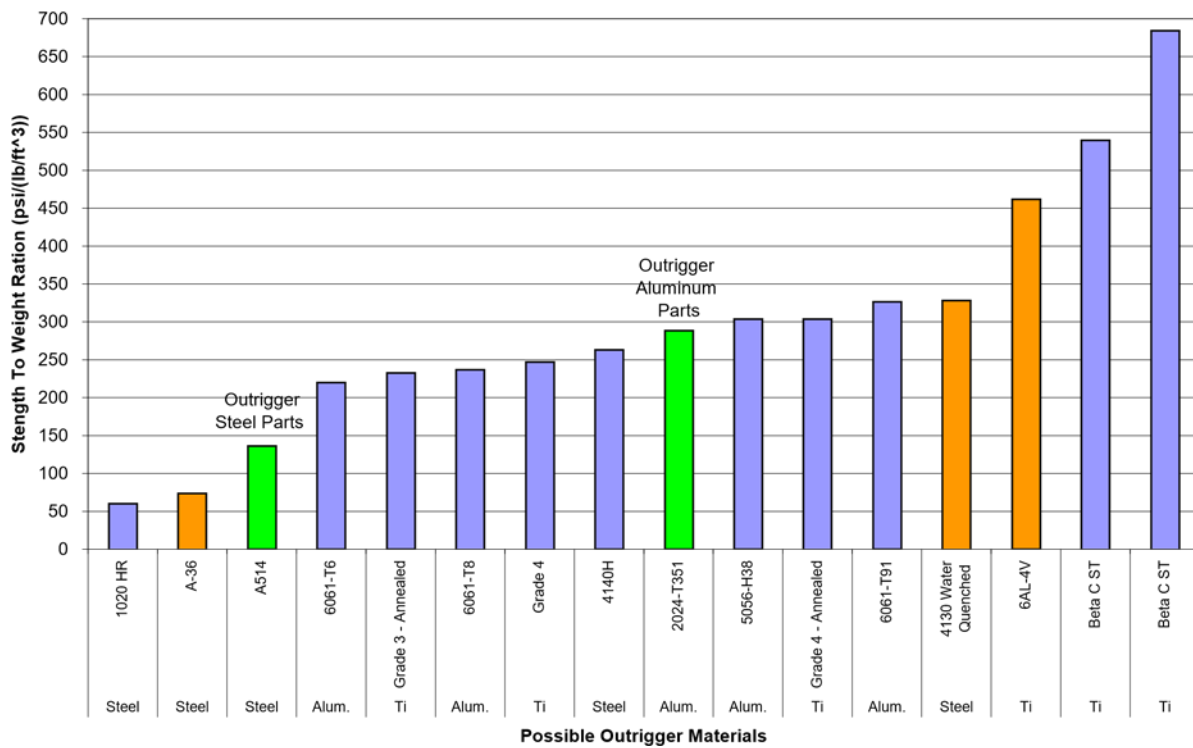

Figure 3.2: Graph of strength to weight ratio, from left to right the graph is organized in order of increasing strength to weight ratio. Orange bars represent considered materials. Green bars represent materials selected for use in designing the new class 8 outriggers.

<sup>4</sup> ASTM A514 has special requirements for welding. There are maximum temperatures for weld inter-passes and type of filler rod to be used. More information is provided in the Appendix.

### 3.3 Skid Plates and Wheel Considerations

The previously mentioned research yielded what solutions were being used at the ends of the outriggers at the point of contact between outrigger and test surface to arrest the test vehicles roll motion. It was found that typically a large truck axle, tire and rim were utilized. A few instances were found in which a skid plate had been developed. NHTSA VRTC's experience with the interface at the end of the outriggers was limited to the large truck axle, tire and rims for class 8 vehicle research. An example of this type of design is shown in Figure 3.3. NHTSA light vehicle research programs were utilizing a hemispherical puck at the ends of their outriggers, so researchers were leaning towards implementing something (skid plate or hemispherical puck) similar for the design of the new class 8 outriggers. Figure 3.4 shows NHTSA light vehicle outriggers and hemispherical puck design.



**Figure 3.3:** Photo of the UMTRI outrigger truck wheel/tire axle assembly; it uses a dual wheel with one tire mounted on the outer rim.



**Figure 3.4:** Photo shows example of NHTSA's light vehicle titanium outriggers. Outrigger has hemispherical skid pucks mounted at the ends of the outrigger. The pucks are made of Ultra-High Molecular Weight (UHMW) plastic and they have been found to be a very light and durable especially when compared to castors assemblies.

The skid plate design was more favorable than the wheel that researchers were accustomed to. It was lighter and significantly reduced the roll inertia effects of adding outriggers to a test vehicle. However, the skid plate required stronger outrigger beams to support the extra forces associated with the skidding occurring at the interface with the test surface. This friction force can be as high as 30 percent of the normal/vertical load on the outrigger skid plate. Other disadvantages to the skid plate were that it required a hinge or ball joint to allow it to conform to a test surface as the test vehicle rolled and it has a leading edge which can catch non-uniform pavement. So the hemispherical skid puck design was favored since it did not require a joint or special attention around leading edges. To accommodate different angles that the outriggers may be mounted at,

the puck was turned vertical so that its axis was now parallel to the test surface. While looking at this design it became obvious that if the puck were given the freedom to rotate it would eliminate the undesirable friction force in the fore and aft directions of travel. So the plastic puck became the plastic wheel. Figure 3.5 shows some of the 3-D modeling design work performed with both skid plates and plastic wheels. Table 3.2 shows the weight and inertia effects of the various wheel/plate assemblies considered. From the table, it can be seen that there is a clear advantage to the plastic wheel and skid plate designs over the traditional rubber truck tire, rim and axle. Therefore, researchers choose the plastic wheel for further design work and it was eventually implemented in the manufactured outriggers.

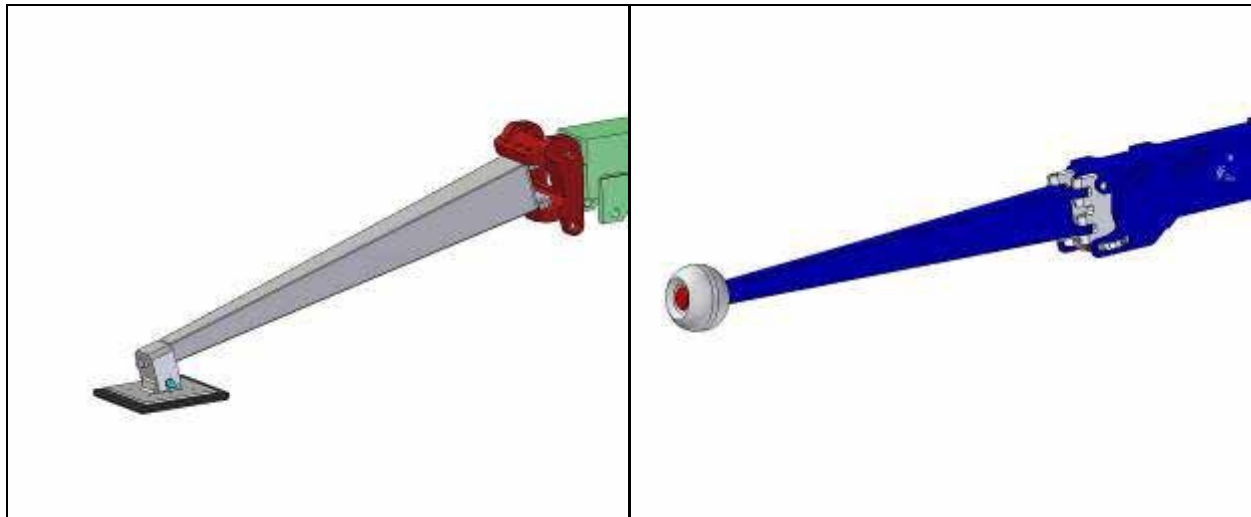

**Figure 3.5:** Left shows a skid plate design considered for the new NHTSA class 8 outriggers. Right shows the High Density Polyethylene (HDPE) plastic wheel chosen for the new NHTSA class 8 outriggers.

**Table 3.2** Wheel and skid plate contributions to vehicle weight and roll inertia.

Part	Weight of Assembly Each (lbs)	Calculated Part Roll Moment of Inertia (lb-ftsec <sup>2</sup> )	Contribution to Roll Inertia of Unloaded Trailer [Trailer = 7346 lb-ftsec <sup>2</sup> ]. (Values in Percent)
UMTRI Wheel\Tire Assembly	226	857	11.7
NHTSA HDPE Wheel [Final Design]	36.7	132	1.80
NHTSA Skid Plate [Final Design]	51.7	194	2.64

### 3.4 Mounting Considerations

The new outriggers were designed to be easily mounted to both flatbeds and box vans with only simple requirements for mounting. Examples of mounting adaptations are shown in Section 5.1. The new outriggers can be mounted to frame rails as narrow as 40 inches on flatbeds and to the bottom of trailers with clearances to the ground plane between 26 – 45 inches. The outriggers will mount to other types of trailers or trailer outside this width and height range; however, they may require considerably more complex mounting adaptations.

### 3.5 Determining Outrigger Width

The width of the outriggers was determined with a few assumptions and mathematical equations based on rigid body geometry. Assumptions were that the clearance between the outrigger wheel and the test surface would be adjusted to 10-11 inches and that the maximum distance between any given trailer axle's outer tires was less than 100 inches. The outrigger wheel clearance height controls the allowable roll angle of the trailer and the value of 11 inches was based on past experience with the UMTRI outriggers. The distance of 100 inches between outer edges of the outer tires of a trailer axle was determined from measurements from NHTSA's test trailers. This distance was derived from the fact that once suspension travel of the trailer is exhausted, the trailer pivots about the outer edges of the outer tires of the widest axle. Given those assumptions the length of the new outriggers was selected based on a desired allowable roll angle. Past test track data has indicated that the allowable roll angle needs to be between 7.5 – 8.5 degrees. This range of allowable roll angles was found to allow the trailers to roll throughout their entire range of suspension travel without outrigger interference. Typical outrigger contact was observed when the wheels<sup>5</sup> of the trailer were between 2 – 6 inches. Table 3.3 shows a range of desired allowable roll angles and what the approximate length of outrigger would be need to avoid exceeding those desired roll angles. To be conservative, the outrigger length chosen was 269 inches knowing the adjustability of the outriggers would easily accommodate larger allowable trailer roll angles. In comparison, the UMTRI outriggers are approximately 265 inches wide.

**Table 3.3** Table used to select the outrigger width.

<b>Desired Allowable Roll Angle ( ° )</b>	<b>Wheel Clearance From Ground (in.)</b>	<b>Track Width (in.)</b> (Outer edge of tire to opposite outer edge of tire)	<b>Approximate Length of Outrigger (in.)</b>
5.5	11	100	329.5
6.0	11	100	310.5
6.5	11	100	294.3
7.0	11	100	280.5
<b>7.5</b>	<b>11</b>	<b>100</b>	<b>268.5</b>
8.0	11	100	258.1
8.5	11	100	248.8
9.0	11	100	240.6
9.5	11	100	233.3
10.0	11	100	226.7
10.5	11	100	220.7

### 3.6 Structural Design

Structurally, the new outriggers were modeled with Solid Edge V15 3-D modeling software and they were analyzed with finite element analysis (FEA) software written by ALGOR (FEMPRO 20.02). The structural design was constrained by:

<sup>5</sup> Wheels in this instance are referring to the trailer wheels that are traveling through the inner portion of a curve and have a decreasing normal load due to weight transfer to the tires in the outer portion of the curve.

1. The design load of 11,000 lbs.
2. Safety factor of 3 or higher.
3. Allow the attachment of plastic wheels.
4. They must accommodate a height range of 26-45 inches.
5. Their overall width should be approximately 269.0 inches.
6. Their transport width should be less than 102 inches.
7. Steel parts are fabricated with
  - a. Plates – ASTM A514.
  - b. Tubes – ASTM A500 and ASTM A53.
8. Aluminum parts made from 2024-T351.
9. Fasteners are SAE Grade 8.

Figure 3.6 shows the resulting design of the new outriggers in an exploded view with the name of each part and an estimate of weight. The total estimated weight excluding some mounting bracketry and small fasteners is estimated to be 1490 lbs. A bulk of the mass is located in the Inboard Beam at 600 lbs with an additional ~250 lbs in hardware and hinges. This large amount of mass was located under the trailer near its center of gravity so that its inertial effects were minimized. Table 3.4 shows a summary of the results from the finite element analysis.

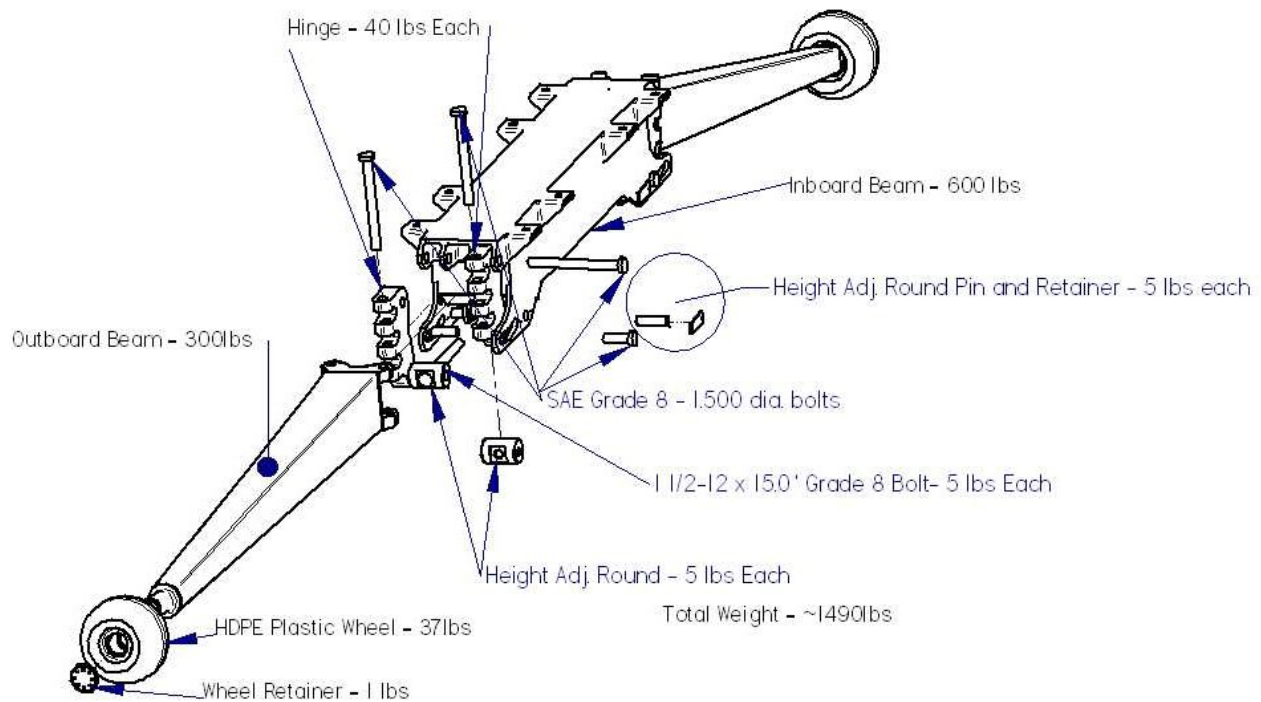

**Figure 3.6:** Exploded view of new outriggers.

In the Table 3.4, from left to right, the header lists each new outrigger's part, the type of material, the materials estimated yield strength, and the safety factor associated with an 11,000 lb vertical load on the plastic wheel at the end of the outrigger. The minimum safety factor was observed with the height adjustment round at 3.2 and the maximum observed was over 5 with the retainer

cap that retains the wheel to the axle. Further details on each part's design are detailed in subsections of this chapter.

**Table 3.4:** Outrigger FEA estimates of safety factor for an input of 11,000 lb vertical load to the outrigger's plastic wheel.

Part	Material	Yield Strength (psi)	Safety Factor
Height Adj. Round	Aluminum	47,000	3.2
Outboard Beam	Steel	100,000	3.3
Inboard Beam	Steel	100,000	3.8
Hinge	Aluminum	47,000	3.8
Wheel	Plastic	3,000	4.5
Retainer Cap	Aluminum	47,000	~5

### 3.6.1 Height Adjustment Round

Figure 3.7 shows the detailed drawing of the Height Adjustment Round. It is used to adjust the height of the outrigger wheel with respect to the ground plane. There are 4 required per outrigger assembly and they are machined from aluminum 2024-T351. Two are needed with threaded holes through the middle, detailed in Figure 3.7, and two are needed with non-threaded holes through them to allow an adjustment screw to rotate freely. Their assembly in the main beam is shown in Figure 3.8. Locking nuts are used to lock all rotating assemblies down once desired wheel height is set. The joint is further constrained by the bolts through the slider in the Inboard Beam. Those bolts are tightened to greater than 500 ft/lbs which gives the lower joint more stability and supports approximately 50 percent of the load going through that location.

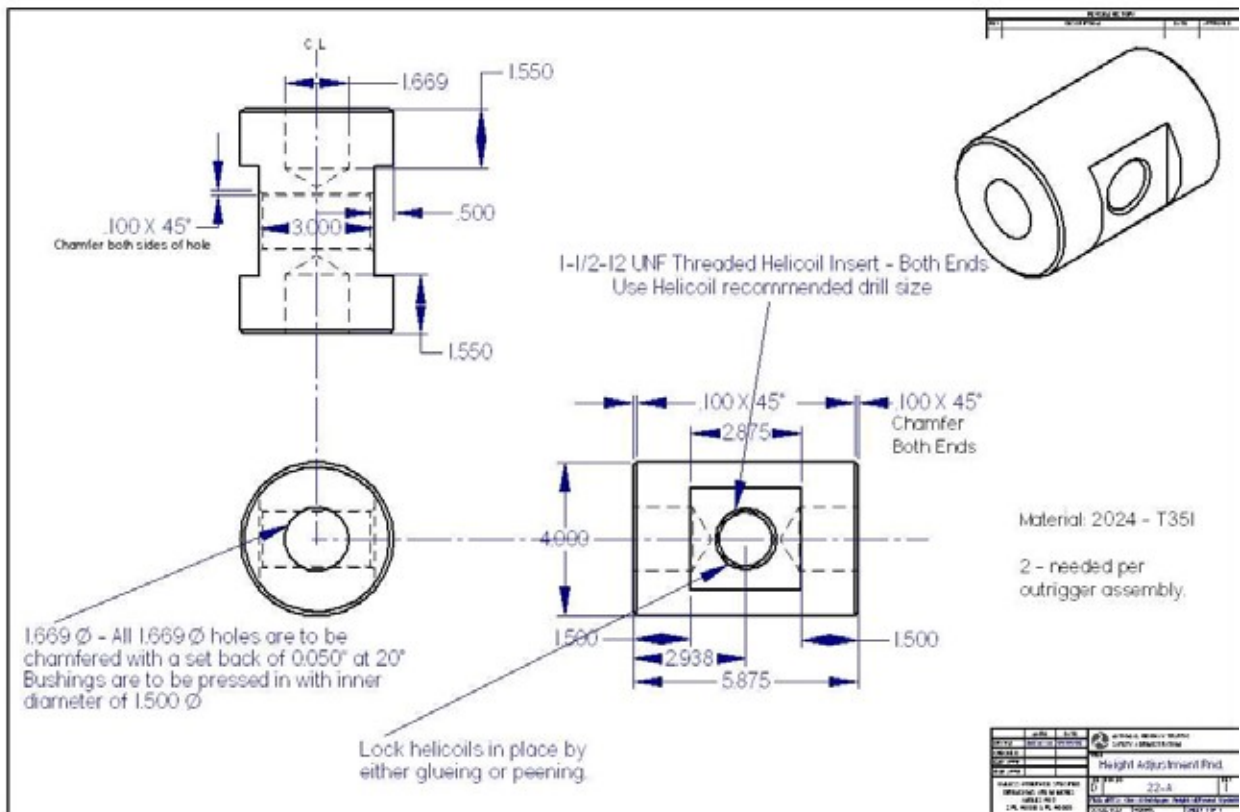

**Figure 3.7:** Detailed drawing of the Height Adj. Round. There are a total of 4 needed per outrigger assembly. Two are built to the exact details in the drawing above and two are made with a though hole in place of the 1-1/2-12 UNF threaded hole through the middle (a larger figure of the drawing is located in Appendix).

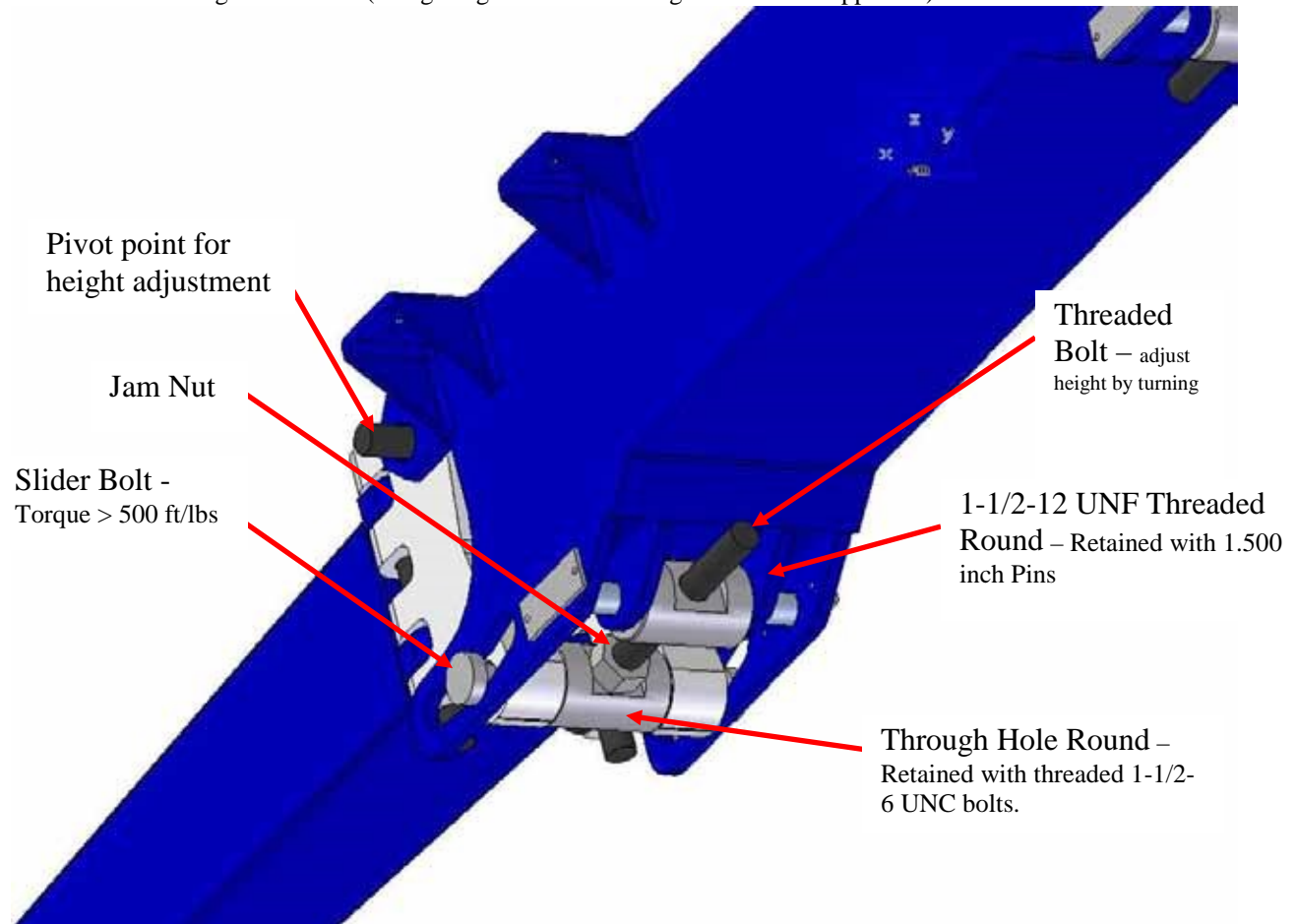

**Figure 3.8:** Diagram of the bottom side of the outriggers. In this view the Height Adj. Rounds are shown. The height of the outrigger wheel is adjusted with these parts by turning the threaded bolt which forces the outriggers to pivot about the upper joint on the hinges. *NOTE: To adjust the outrigger height all fasteners should be loosened. Tighten and reset slider bolts to 500 – 800 ft/lbs when finished.*

### 3.6.2 Outboard Beam

The Outboard Beam is made of A514 Steel plates<sup>6</sup> and A53 Steel pipe (Axle). It is a tapered hollow beam design that is welded together to get a decreasing weight/linear foot as you move towards the axle end of the outrigger. This reduces weight and inertial affects of adding outriggers to a test vehicle, yet maintains material around the stress concentration areas associated with the mounting points. Figure 3.9 shows the stress distribution on the outrigger when subjected to an 11,000 lbs vertical load. Blue colors indicate lightly stressed locations. As stress increases the colors begin to transition to the highest stress indicated by the red coloring. The overall minimum and maximum values are shown in the bottom right hand corner of the figure. The mounts are

<sup>6</sup> Parts with thicknesses of 0.75 inch and smaller were laser cut. Parts with thicknesses greater than 0.75 inches were water cut and then machined to final dimensions. Cutting operations were performed using the electronic dimensioned \*.dwg files as guides, those files are also shown as dimensioned drawings in the appendix.

carrying the bulk of the stress from the load. Those loads are distributed to the Inboard Beam through two 1.5 inch pins/bolts. The dimensioned drawing and free body diagram for the Outboard Beam is located in the Appendix.

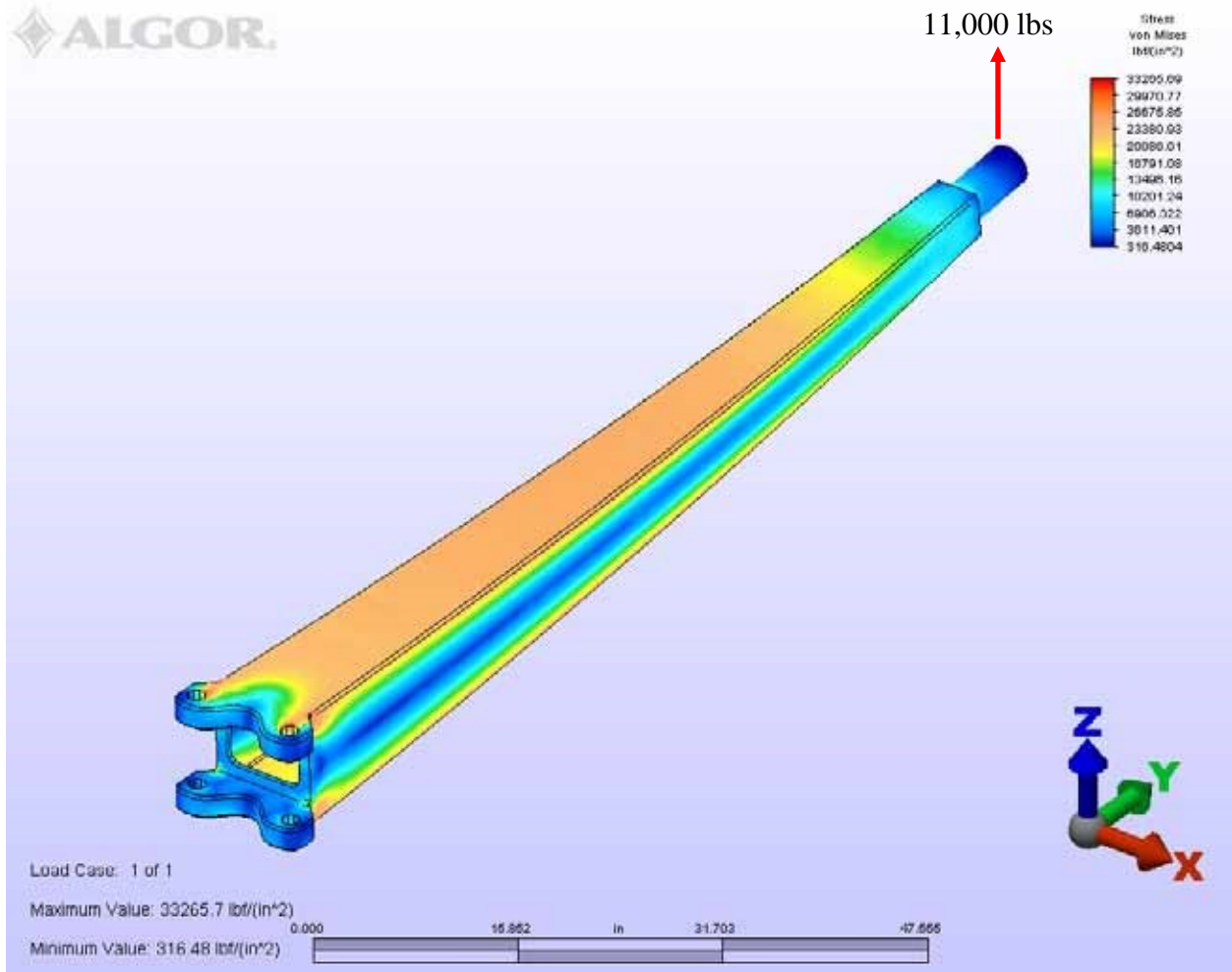

**Figure 3.9:** FEA of Outboard Beam

### 3.6.3 Inboard Beam

Similar to the Outboard Beam the Inboard Beam is constructed from A514 plate<sup>7</sup> and A500 square tubing. The square tubing is used for the mounting brackets. All parts are cut and welded together to attain a hollow beam that concentrates the mass on the mounting locations. This type of construction allows the design to use a varying cross-sectional area to achieve larger safety factors without increasing weight. Its dimensioned drawing is located in the Appendix.

### 3.6.4 Hinge

The hinges are designed to allow the adjustment of outrigger wheel height (Pivot up and down) and the ability to fold (pivot in the fore and aft directions) the outriggers for transport. The hinges

<sup>7</sup> All flat parts were laser cut from large plates of ASTM A514. The cutting operations were performed using electronic dimensioned \*.dwg files as guides, those files are also shown as dimensioned drawings in the appendix.



are machined from 2024-T351 aluminum. This particular design was arrived at after many iterations and trial and error type modeling. The design started off as one piece made of steel which is shown in Figure 3.10. The same figure also shows the final design on the left (2 hinges needed per Outboard Beam, see figure 3.6). The final design requires less machining and is much lighter at 60 pounds versus 252 lbs for the single hinge type design when fabricated from steel. The single hinge would have a comparable weight when fabricated from aluminum however; FEA showed that it had an unacceptable safety factor of  $\sim 1.5$ . Therefore, the design on the right was selected. Free body diagram and dimensioned drawing are located in the Appendix.

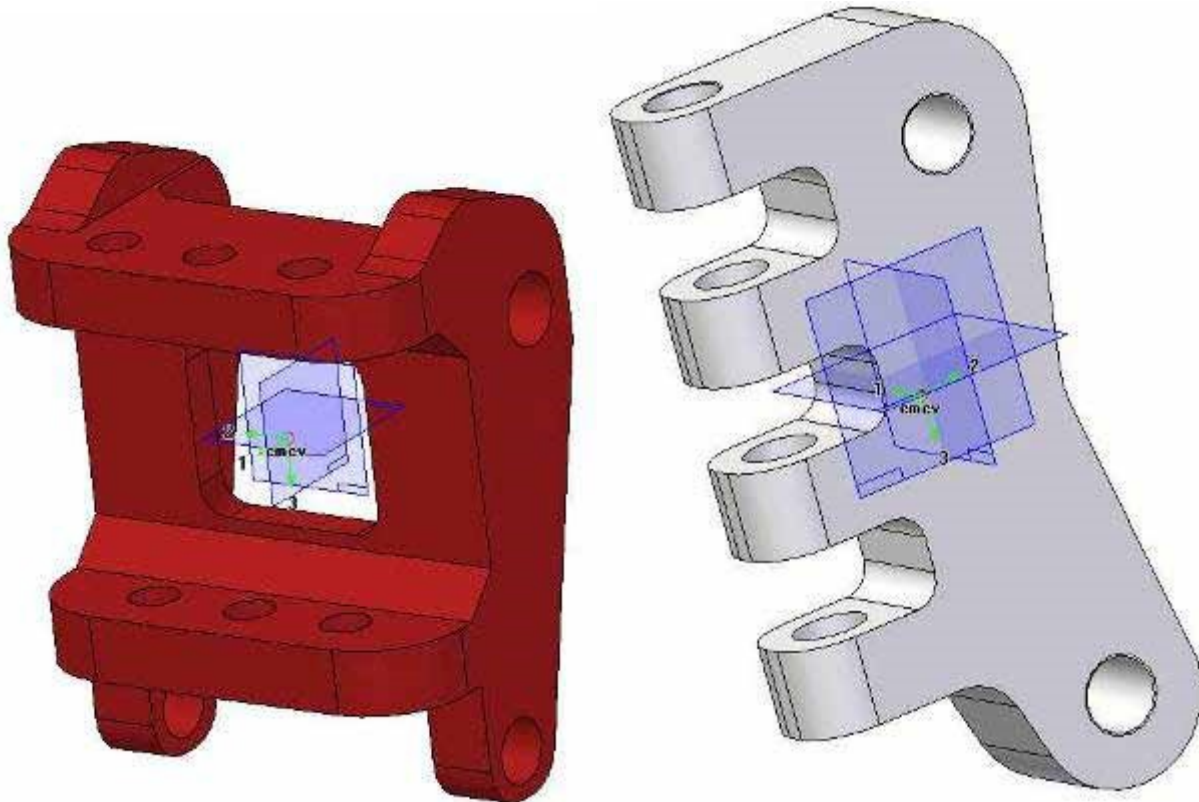
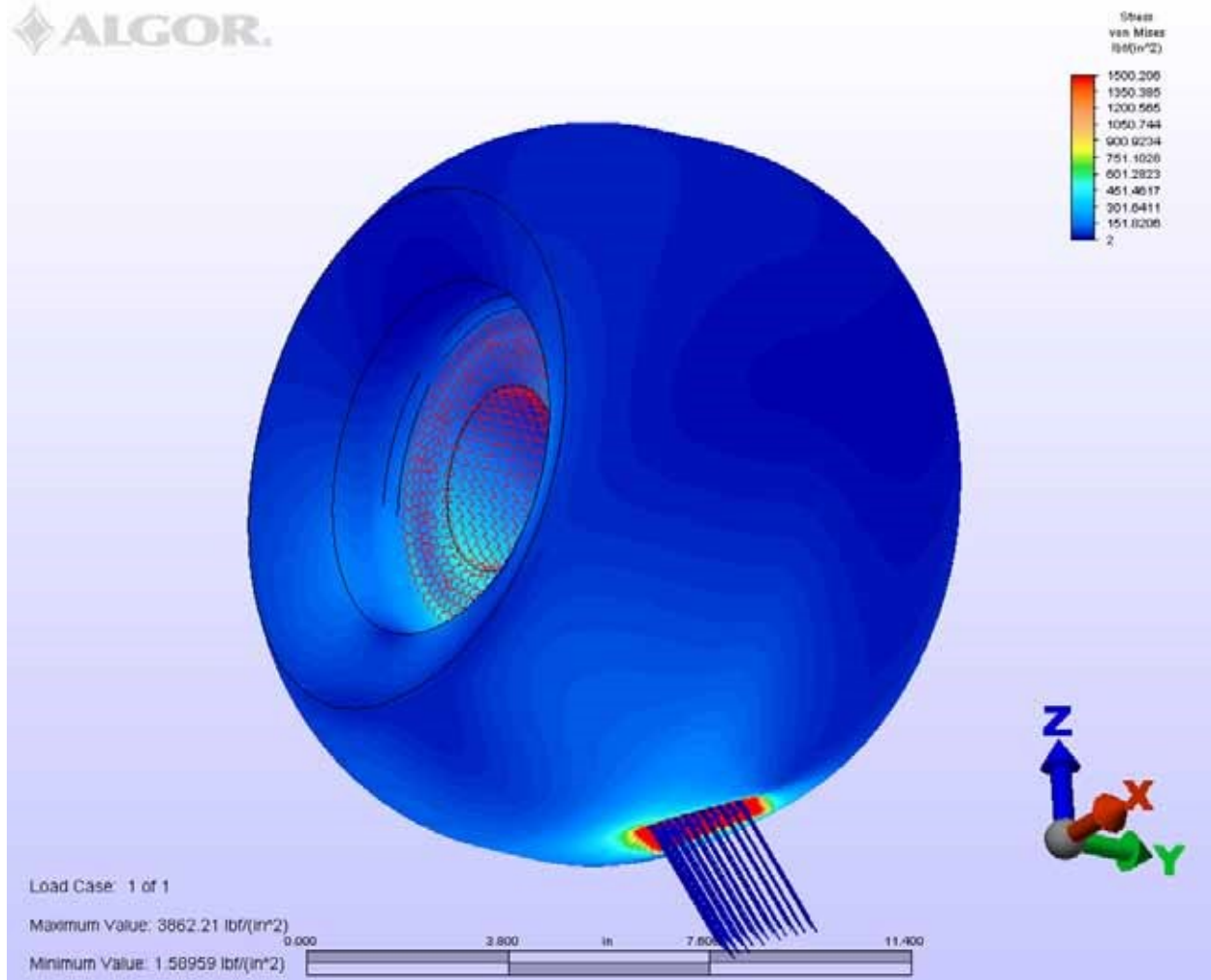

**Figure 3.10:** Left is an example of an early dimensional model which turned out to be an unacceptable design for weight and safety factor reasons. Right shows the final solution that allows the adjustability desired for the new outriggers without sacrificing weight.

### 3.6.5 Wheel

The wheel as discussed earlier was arrived at through experimentation with different orientations of the spherical skid puck design employed on NHTSA's light vehicle titanium outriggers. The first several iterative designs used a larger diameter wheel made from Ultra-High Molecular Weight (UHMW) plastic. However, it was found that UHMW was not typically manufactured to such sizes. Further research revealed that High Density Polyethylene (HDPE) plastic was manufactured in 14.0 inch diameter rounds. Comparatively, the UHMW and HDPE are very similar materials that are resistant to impact loads and have relatively low densities. FEA revealed that a larger axle (3.5 inch diameter) would be required to lessen the stress associated with the impact forces. FEA also revealed that the wheel would wear initially until the worn area was large enough to distribute the input forces and thereby bring the stress levels below the plastics yield

stress value. This can be observed in Figure 3.11 which shows an example of the FEA analysis that was performed. Looking at the figure, the analysis shows that the largest stresses on the HDPE wheel occur from the impact with the test surface. It also shows that the input loads are well distributed at the hole for the axle shaft. The dimensioned drawing for the wheel is located in the appendix.



**Figure 3.11:** FEA example of HDPE plastic outrigger wheel. Wheel is constrained at the hole and an 11,000 lb magnitude load is applied at a 30 degree angle to the vertical plane. High stresses are observed around the impact and are distributed very low levels at the hole for the axle shaft.

### 3.6.6 Retainer Cap

The wheel Retainer Cap is bolted to the end of the axle on the Outboard Beam and keeps the wheel from in sliding axially on the axle. Its dimensioned drawing is shown in Figure 3.12. It is machined from 2024-T351 Aluminum. The cap is bolted on with eight 5/16-24 UNF SAE grade 8 bolts. This particular part is designed to fit the wheel and axle and weighs approximately 0.6 lbs. Force is put on the cap during outrigger contact for centrally mounted outriggers. The forces are trying to pull the wheel from the outrigger. That force is generated from friction between the wheel and the test surface during an outrigger strike. Literature on the HDPE plastic wheel indicate that its friction co-efficient is approximately 0.3. So the force on the cap was estimated to be 30

percent of an 11,000 lbs normal load. Using those estimates a FEA of the cap was performed; the cap was found to be more than strong enough with safety factors of over 5. Weight reductions were not considered since the part was already considered to be light.

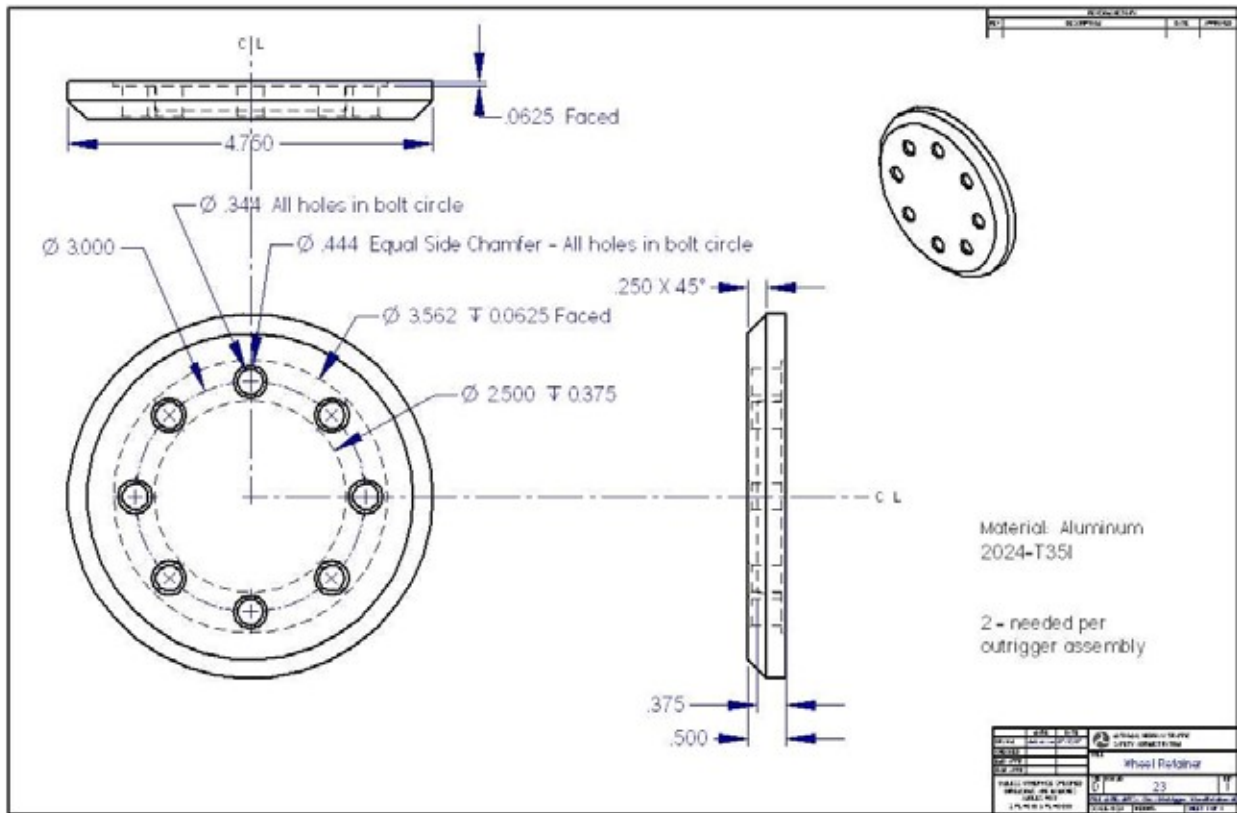

Figure 3.12: Detailed Drawing of the new outrigger wheel Retainer Cap.

### 3.7 New Outriggers Physical Properties

Once the FEA was finished a comparison between the new outriggers and the UMTRI outriggers was performed. For the comparison a 3-D model of the UMTRI outriggers was developed so that the physical properties could be estimated and a more direct comparison made between the two models. Table 3.5 shows the weight and inertial reductions of the new outriggers from the UMTRI outriggers.

Table 3.5 NHTSA class 8 outriggers physical property reductions From UMTRI designed outriggers

Weight (percent)	Inertial Property Reduction (percent)		
	Roll	Pitch	Yaw
35.0%	62.7%	87.3%	63.4%

The new outriggers are approximately 35 percent lighter. Their roll and yaw inertia is 62-63 percent of that estimated for the UMTRI outriggers. When adding the outriggers to a trailer; the trailer will dominate the physical properties of their combination especially when loaded. So when looking at combinations of trailers and outriggers, the differences between weight and inertia are less observable, but are still significant. Table 3.6 shows the changes to weight and inertial

properties of a 42.5ft tanker trailer equipped with each set of outriggers. The table shows the loaded trailer with outriggers and then the unloaded trailer with each outrigger.

**Table 3.6 Affects from adding safety outriggers to a simulated 42.5 ft. tanker trailer.**

Simulated Tanker	Outrigger	Weight Change (percent)	Change to C.G. (percent)	Inertial Property Changes (percent)		
				Roll	Pitch	Yaw
<b>Loaded</b> (65K lbs)	UMTRI	3.3%	-1.96%	22.1%	0.52%	1.34%
<b>Loaded</b> (65K lbs)	NHTSA	2.2%	-1.35%	9.8%	0.40%	0.51%
<b>Unloaded</b> (10K lbs)	UMTRI	21.5%	-3.46%	89.3%	33.7%	46.4%
<b>Unloaded</b> (10K lbs)	NHTSA	14.1%	-4.13%	31.7%	26.7%	30.5%

From the table the weight changes observed from adding outriggers to the loaded trailer are very similar for both sets of outriggers at around 2-3 percent. The changes to pitch and yaw inertia were also relatively small at 0.40-1.34 percent. However, the associated roll inertia increase of the loaded tanker with the NHTSA outriggers was observed to be 9.8 percent much less when compared to the 22.1 percent increase observed with the UMTRI outriggers. Larger differences were observed when adding outriggers to the unloaded simulated tanker trailer. Weight gains were 14.1 percent with NHTSA’s outriggers and 21.5 percent with UMTRI’s. The unloaded trailer’s roll inertia was increased by 31.7 percent with the new outriggers versus 89.3 percent for the UMTRI outriggers. Pitch inertia was increased about the same for each given condition between 26.7-33.7 percent. The yaw inertia of the system was increased by 30.5 percent with the NHTSA outriggers and increased by 46.4 percent with the UMTRI outriggers. With these results the new outrigger design was finalized and manufacturing could begin.

#### **4.0 MANUFACTURING**

With the manufacture of the first set of new outriggers, minor revisions to the design were found necessary to increase their ergonomics. These revisions were minor and did not affect overall safety factors of part designs. For example, folding the Outboard Beam on the first set of outriggers was difficult and required a lot of jostling to get the locking pins in and out. The solution required a change to the tolerances in the hole sizes that the locking pins slide through. This change reduced hole/pin misalignment and made the folding process more ergonomic. The only other problem that was observed was the distortion to the Inboard and Outboard Beams during the welding process. Great care and lots of jiggling was required. Even then, distortion of parts was still observed. To alleviate/minimize the interference problems around the joints, each joint’s tolerances were either increased or decreased depending on the observation of the problem during manufacturing. To achieve these joint tolerances, shims were used to evenly space the joints and brackets.

The following sections will discuss the manufacture of the Outboard and Inboard Beams. All other parts (Hinge, Height Adjustment Rounds, Retainer Cap, and Wheel) are relatively simpler to make and are attached during the final assembly to either the Outboard or Inboard Beam. The drawings for those parts are supplied in the appendix. All outrigger parts should be made and on-hand during the manufacture of the Inboard and Outboard Beams. Multiple assemblies and disassemblies of the outrigger parts are required to assure welded parts are in proper locations.

#### 4.1 Outboard Beam – Manufacturing

This section assumes all parts have been made and they are within tolerances that are acceptable to those assembling the outriggers. Figure 4.1 shows the exploded view of the outboard beam. All seams are welded where possible. Multiple weld passes may be required to achieve standard bead sizes. Figures 4.1 through 4.7 show approximately how NHTSA assembled the Outboard Beam.

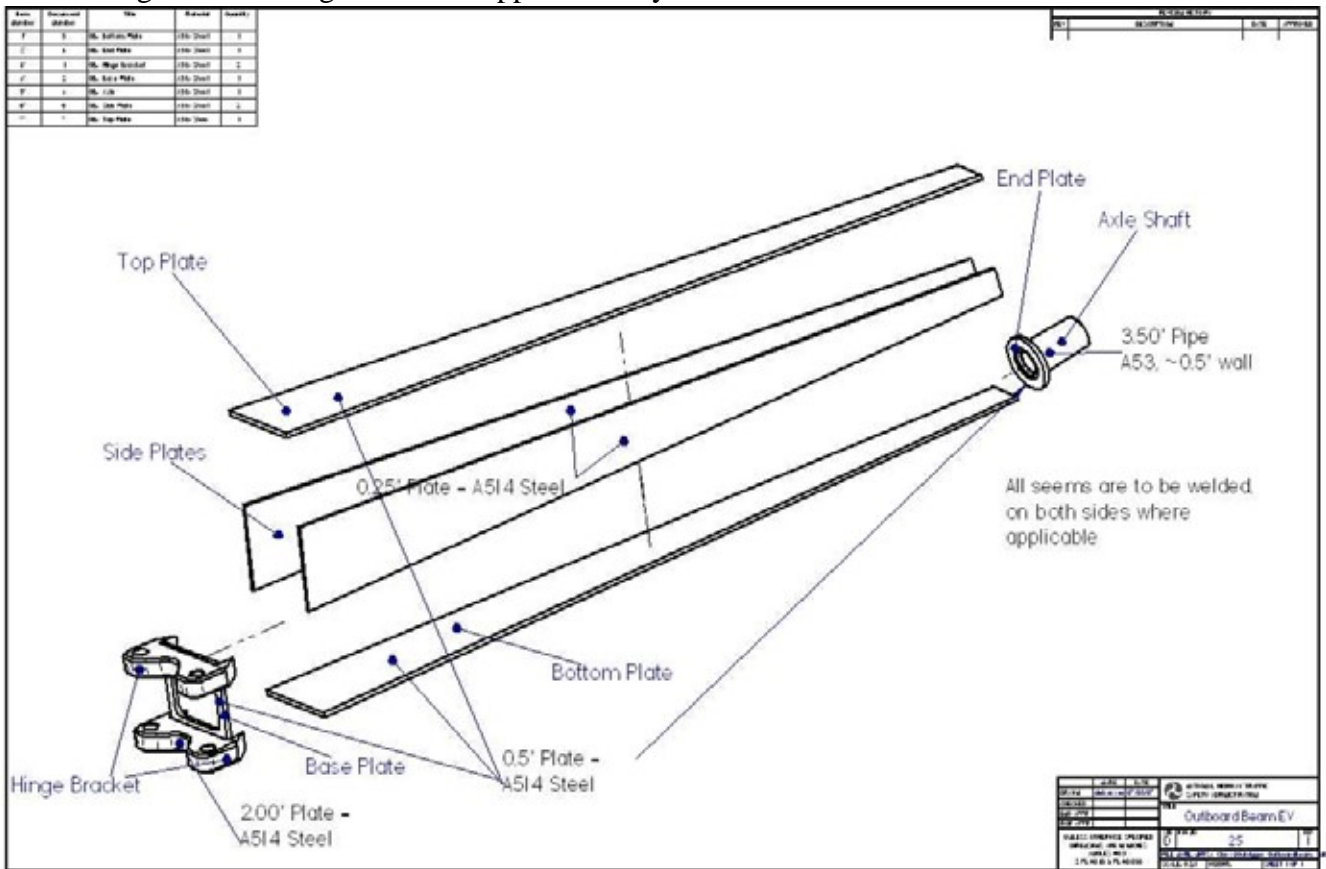

**Figure 4.1:** Assembly details of the Outboard Beam of the new NHTSA class 8 outriggers. Labels on the parts are used in subsequent Inboard Beam assembly drawings.



**Figure 4.2:** Pictures of the fabrication of the outboard beam. Clamps and 90° angle iron pieces are used to jig the plates that form the tapered beam (outer edges are aligned and tacked into place). All outside seams were continuously welded. Inner seams were welded according to what the welder could reach.



**Figure 4.3:** Left: Base Plate is added to the end. Middle: Base plate is welded to the Outboard Beam in the locations that the Hinge Brackets will overlap. Right: Hinge Brackets are being jigged up to weld. The bolts shown in the photo were removed and an aluminum jig was inserted into the holes to assure alignment, see Figure 4.4 (Middle).



**Figure 4.4:** Left: clamping and jiggging of Hinge Brackets. Middle: aluminum jig used to assure alignment. Welding was performed with jig in the holes. Right: finished Hinge Brackets with shoulder bolts in. The bolts should easily slide through holes when finished.



**Figure 4.5:** Left: End Plate and Axle Shaft are welded together. All inside and outside seams were welded. Middle: the weld bead and face of end plate are turned on a lathe to create chamfer and remove any rough edges that would snag HDPE Plastic Wheel. Right: finished Axle Shaft and End Plate are ready for attachment to Outboard Beam.



**Figure 4.6:** Left: End Plate and Axle Shaft are jugged into place for final attachment to the Outboard Beam of the new outriggers. Right: All seams are welded, multiple weld passes maybe necessary. Outboard Beam is complete.

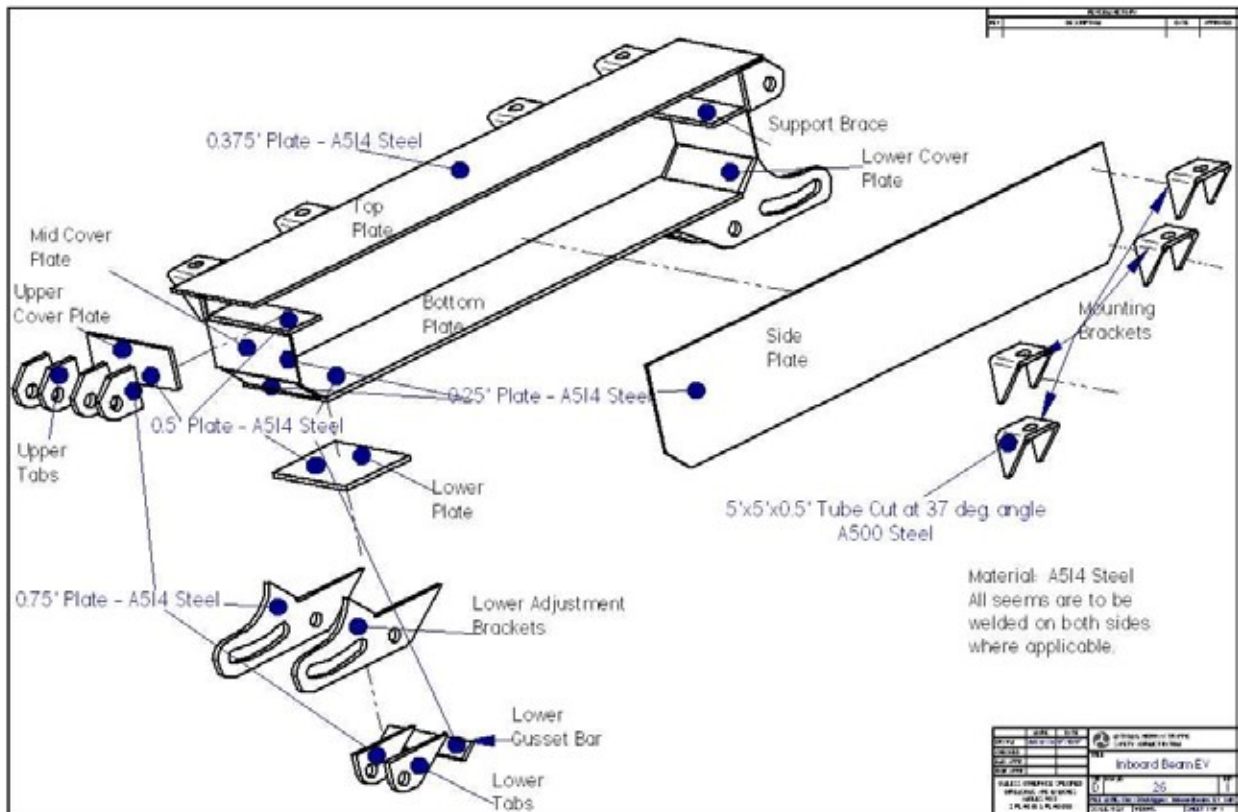



**Figure 4.7:** Finished welded and painted Outboard Beam.

## 4.2 Inboard Beam – Manufacturing

The Inboard Beam was found to be considerably more complex and challenging to assemble and weld than the Outboard Beam. Warping and losses of free play tolerance were observed due to the amount of welding that was required. This was especially true of the first set of outriggers built. By using jigs, clamps, hold downs, and shims, those losses were minimized during the manufacture of the 2<sup>nd</sup> set of outriggers. During the final assembly, a small amount of grinding was required to give the adjustment assemblies free play. Figures 4.8 through 4.21 show approximately how NHTSA assembled the Inboard Beam.



**Figure 4.8:** Exploded view of the Inboard Beam. Labels on the parts are used in subsequent Inboard Beam assembly drawings.

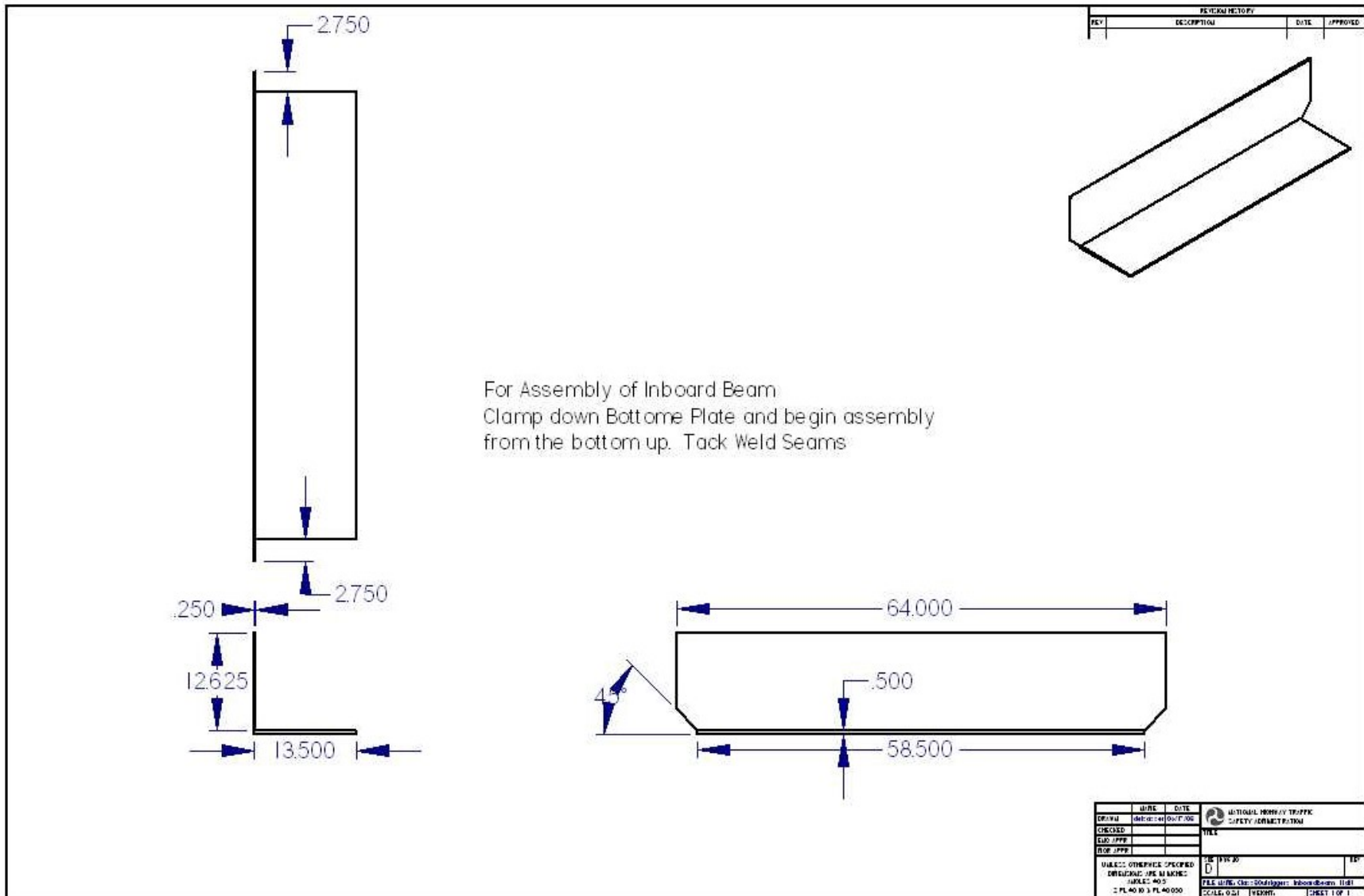

**Figure 4.9:** NHTSA began assembly of the Inboard Beam by tack welding one of the Side Plates to the Bottom Plate. A welding table (flat plate), clamps and straight edges were used to reduce warp from welding.

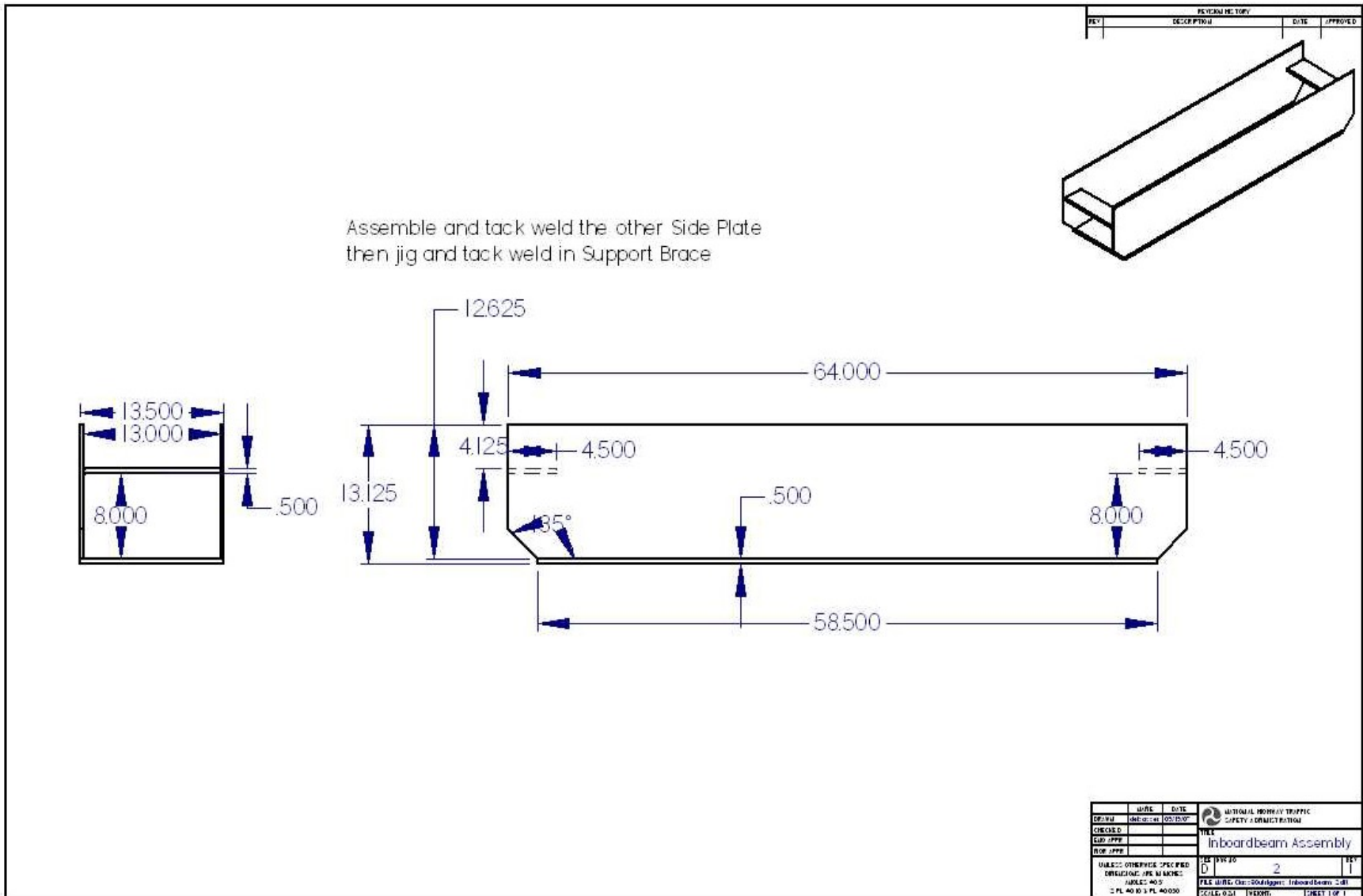

**Figure 4.10:** Second and third steps NHTSA used in the assembly process. Continue to use welding table, clamps and straight edges to reduce warp from welding.

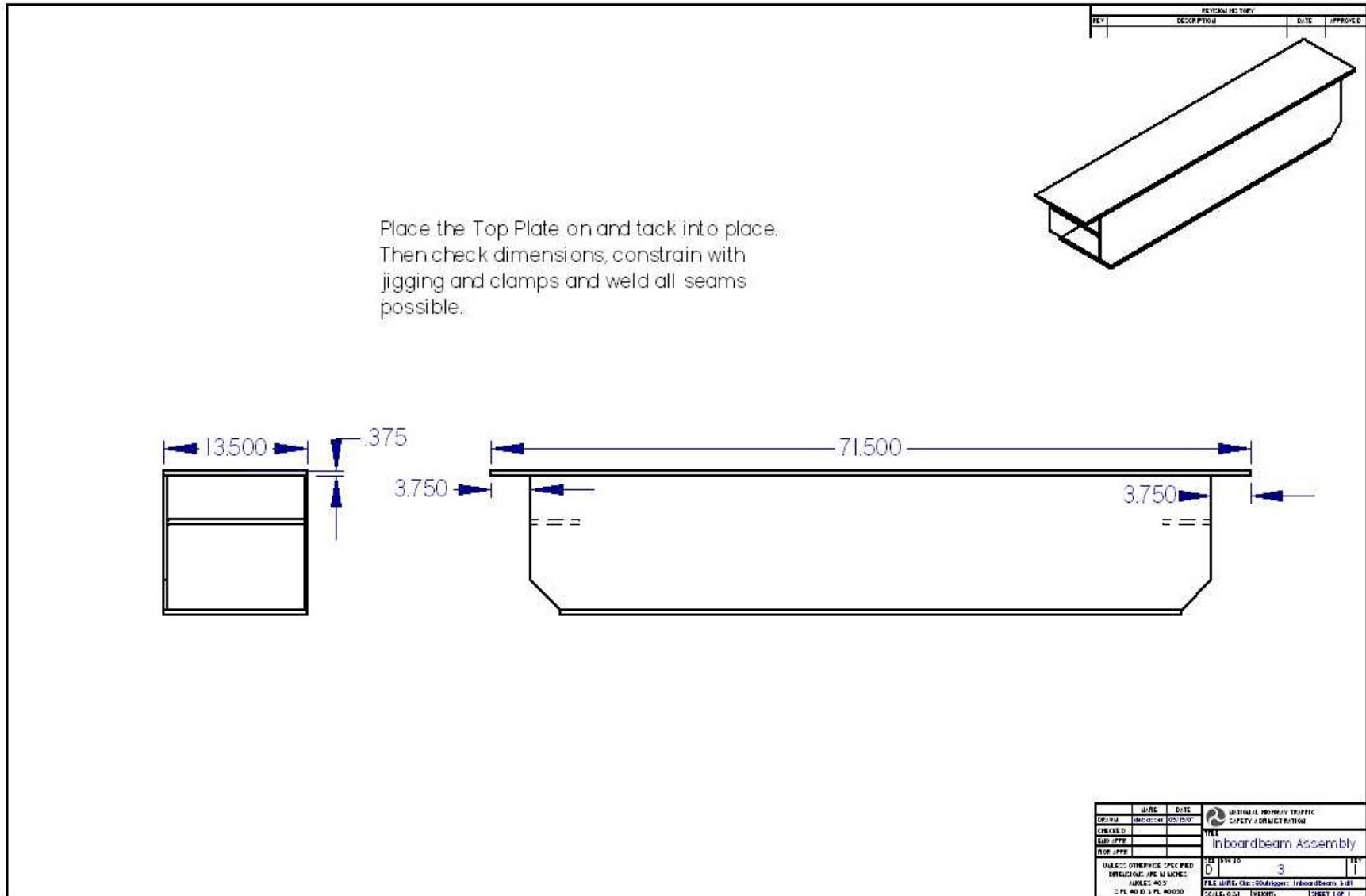

**Figure 4.11:** Fourth step taken was to add the Top Plate. All pieces were tack welded up to this point. Once the Top Plate was tacked in place all seams (inside and out) that could be reach by the welder were welded.

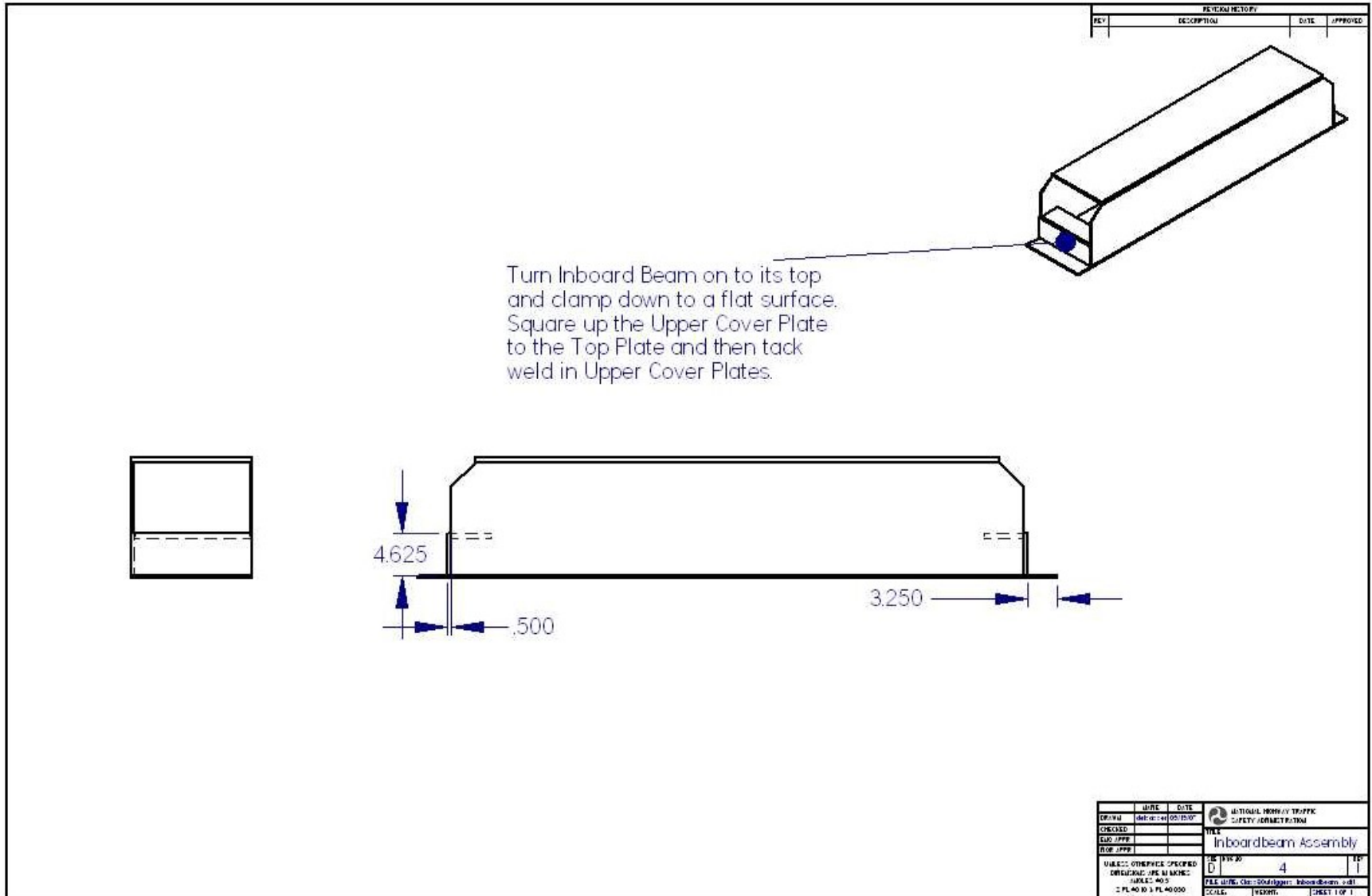

**Figure 4.12:** Fifth step; tack weld in the Upper Cover Plates on each end. They are centered side to side.

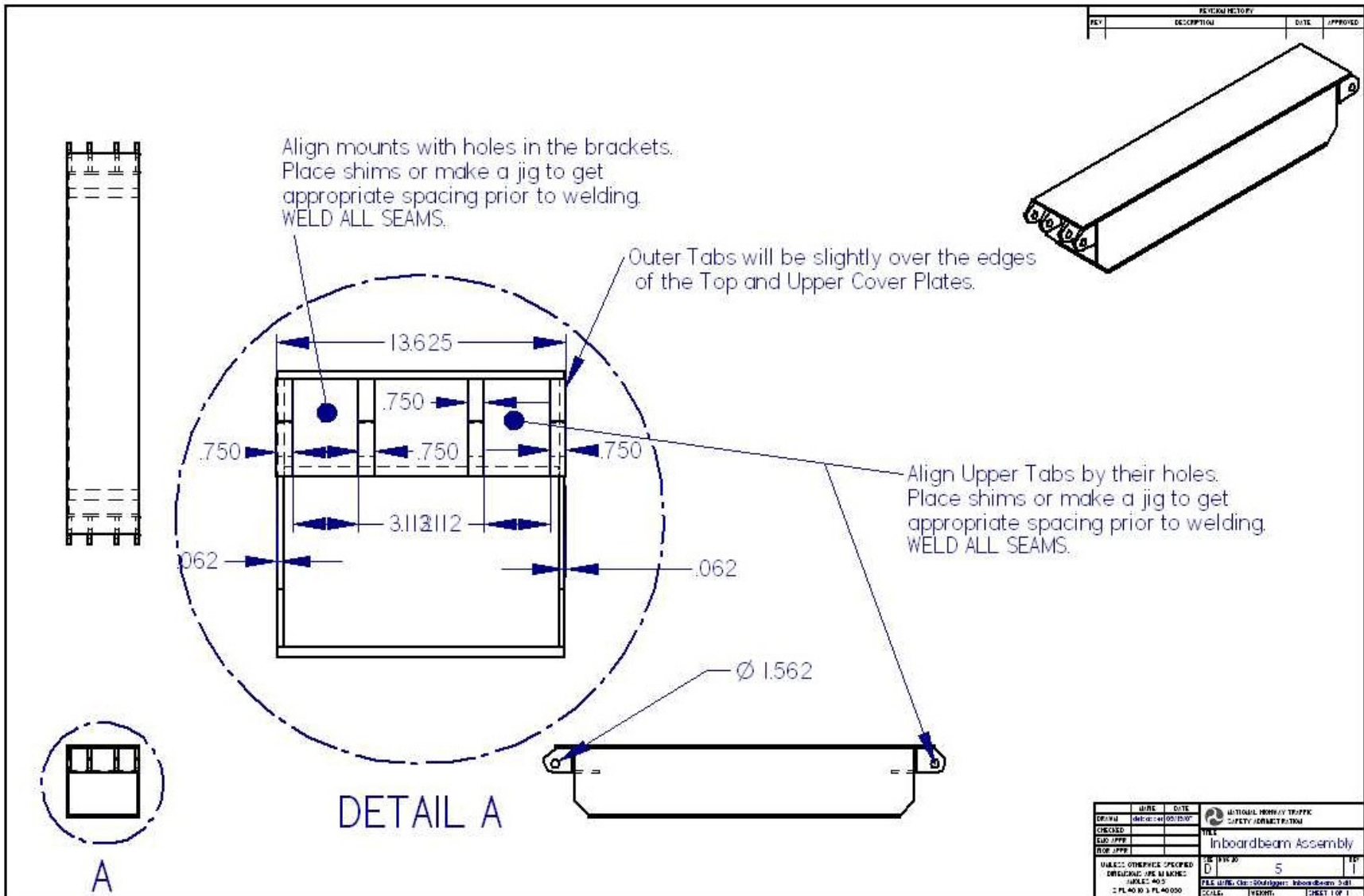
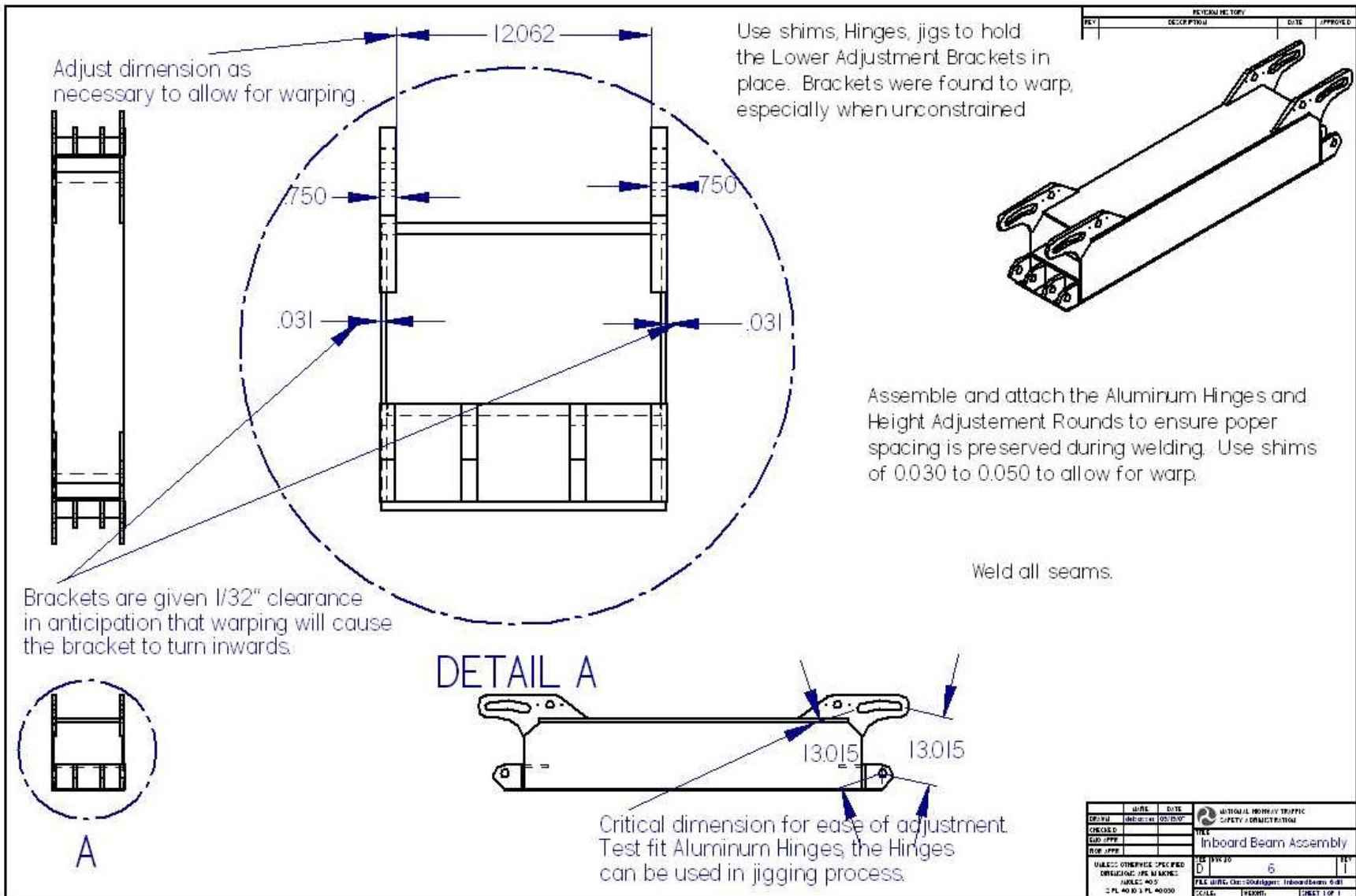

Figure 4.13: Sixth step; tack weld in place the Upper Tabs using the Aluminum Hinges and shims as jigs to assure free play tolerances. All seams were welded.





**Figure 4.14:** Seventh step; Tack weld in place the Lower Adjustment Brackets using Hinges, jigs and shims to assure tolerances. Attachment of this part is critical to the ease with which the height adjustment mechanism can be operated. The Aluminum Hinges, Height Adjustment Rounds should all be bolted in to check for interferences. After the check; the Lower Adjustment Brackets were welded in place.

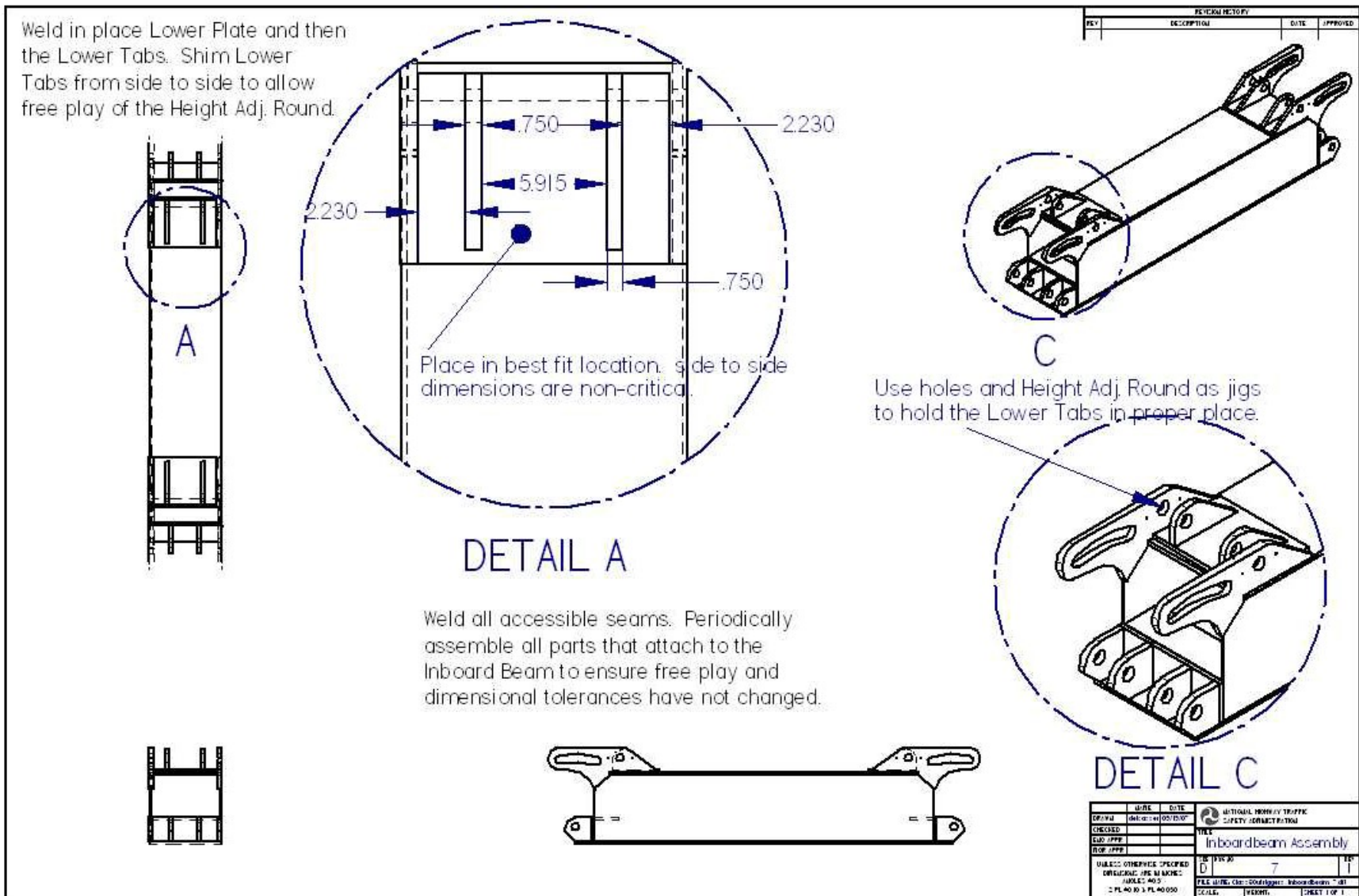

Figure 4.15: Eighth and ninth steps; attach the Lower Plate and Lower Tabs.

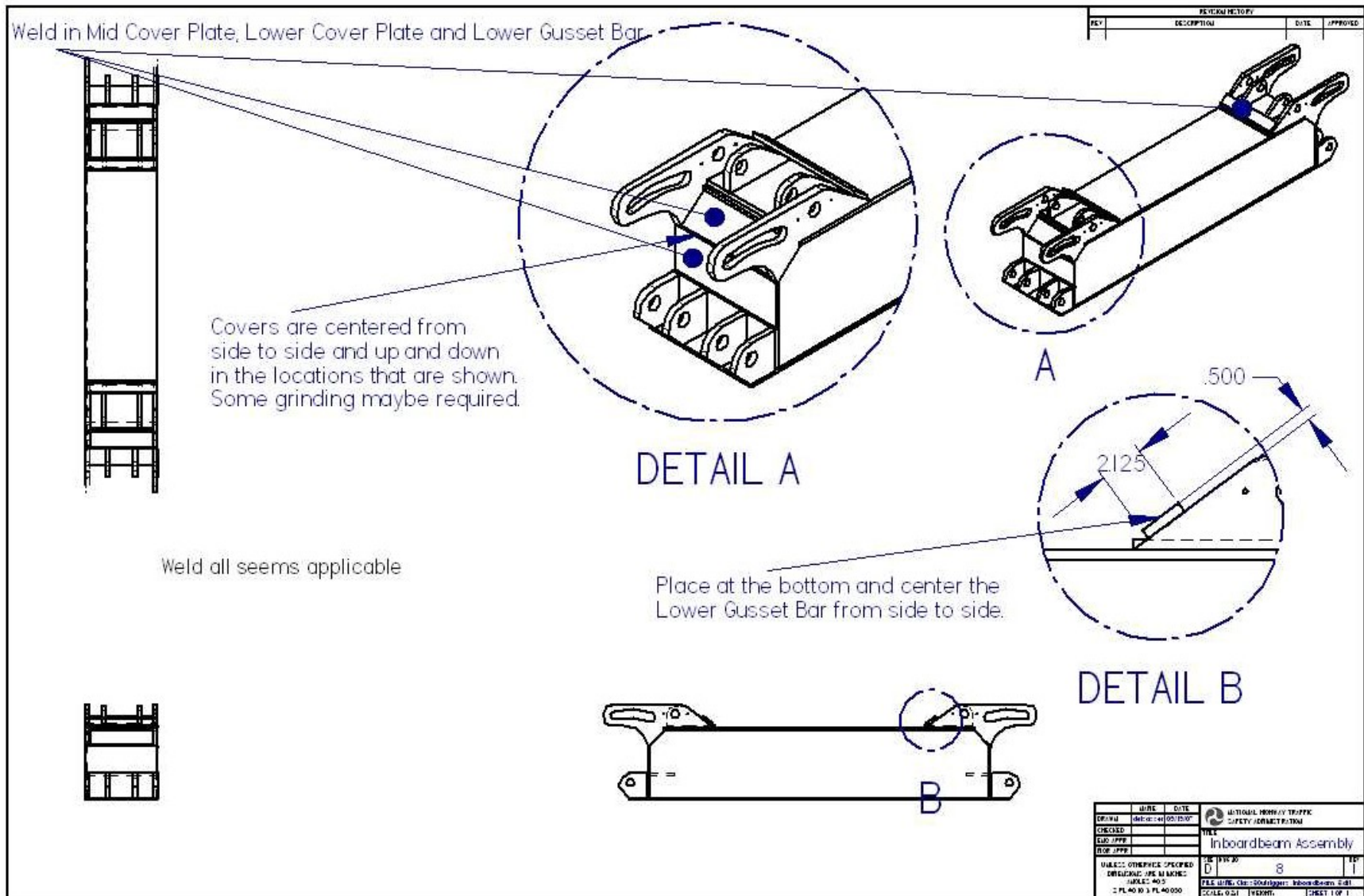
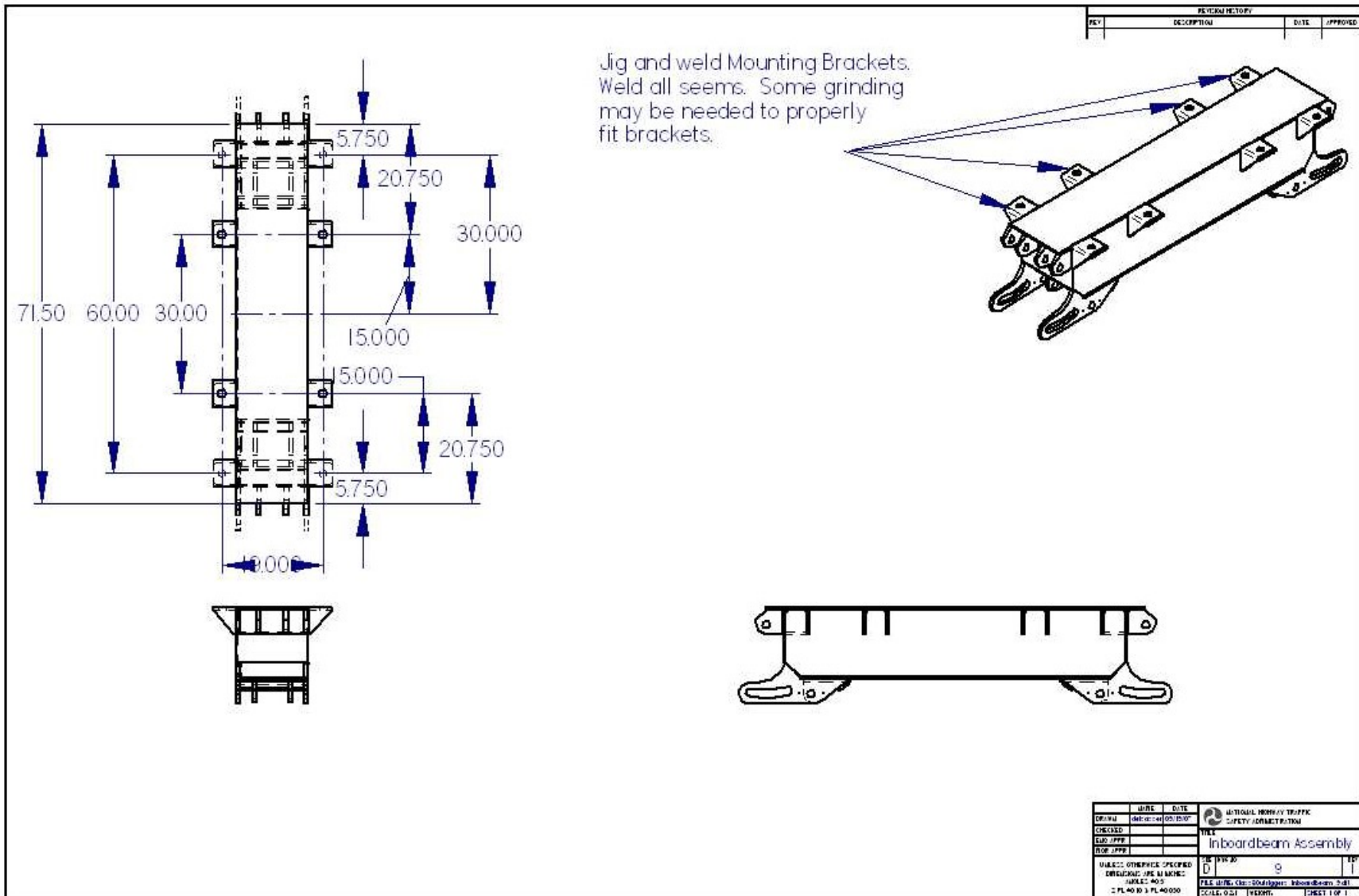
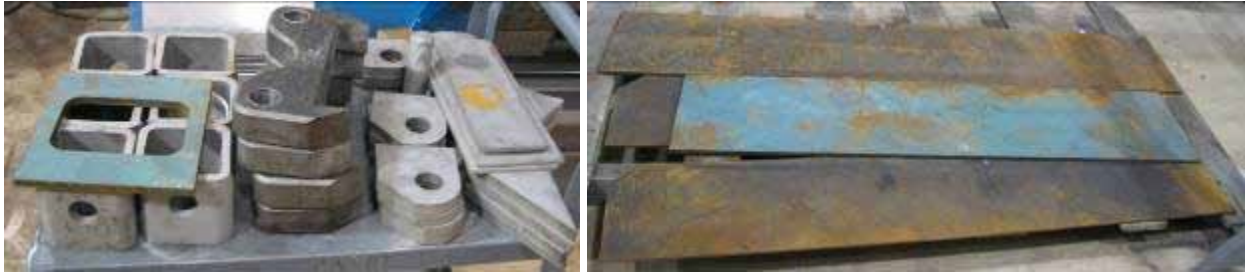

Figure 4.16: Tenth through twelfth steps; Attach the Mid Cover Plates, Lower Cover Plates and Lower Gusset Bars.



**Figure 4.17:** Thirteenth step; attach the Mounting Brackets along the top edge of the Top Plate.



**Figure 4.18:** Left: Small parts needed to assemble the new outriggers. Right: Large plates that are welded together to make up the shell of the Inboard Beam.



**Figure 4.19:** Left: 1<sup>st</sup> step complete clamps have been removed. Right: 7<sup>th</sup> step, critical placement of the Lower Adjustment Brackets. Hinges, all thread, and shims are used to jig into place. Consider tack welding on some straps across the brackets to further constrain warping.



**Figure 4.20:** Left: 8<sup>th</sup> and 9<sup>th</sup> steps have been completed and jiggling has been removed. Right: 12<sup>th</sup> step has been completed; cover plates were welded in place. *Note: Jigs holding the Lower Adjustment Brackets should be left in when welding is taking place on the Inboard Beam. Free play tolerances were lost when those jigs were removed and welding operations performed.*



**Figure 4.21:** Left: 13 were touched up and cleaned to be painted.

Right: final Inboard Beam fabrication; the welds

### 4.3 Final Assembly – Manufacturing

This section gives a general description of the final assembly of the new outriggers. Figure 4.22 shows the assembled outriggers and smaller pictures of the outriggers in the transport position and the hydraulic elevating lift cart used to move and install the new outriggers. Figure 4.23 through 4.25 provide more technical drawings, exploded views and notes regarding the assembly of the new NHTSA class 8 outriggers.



**Figure 4.22:** Center: completely assembled new NHTSA outriggers ready to go under a trailer. Top Left: picture of the outriggers in transport position. Lower Right: Zorin hydraulic elevating lift cart with payload capacity of 2000lbs and height range of 15.0 - 39.0 inches. It is used to ease the moving and installation of outriggers.

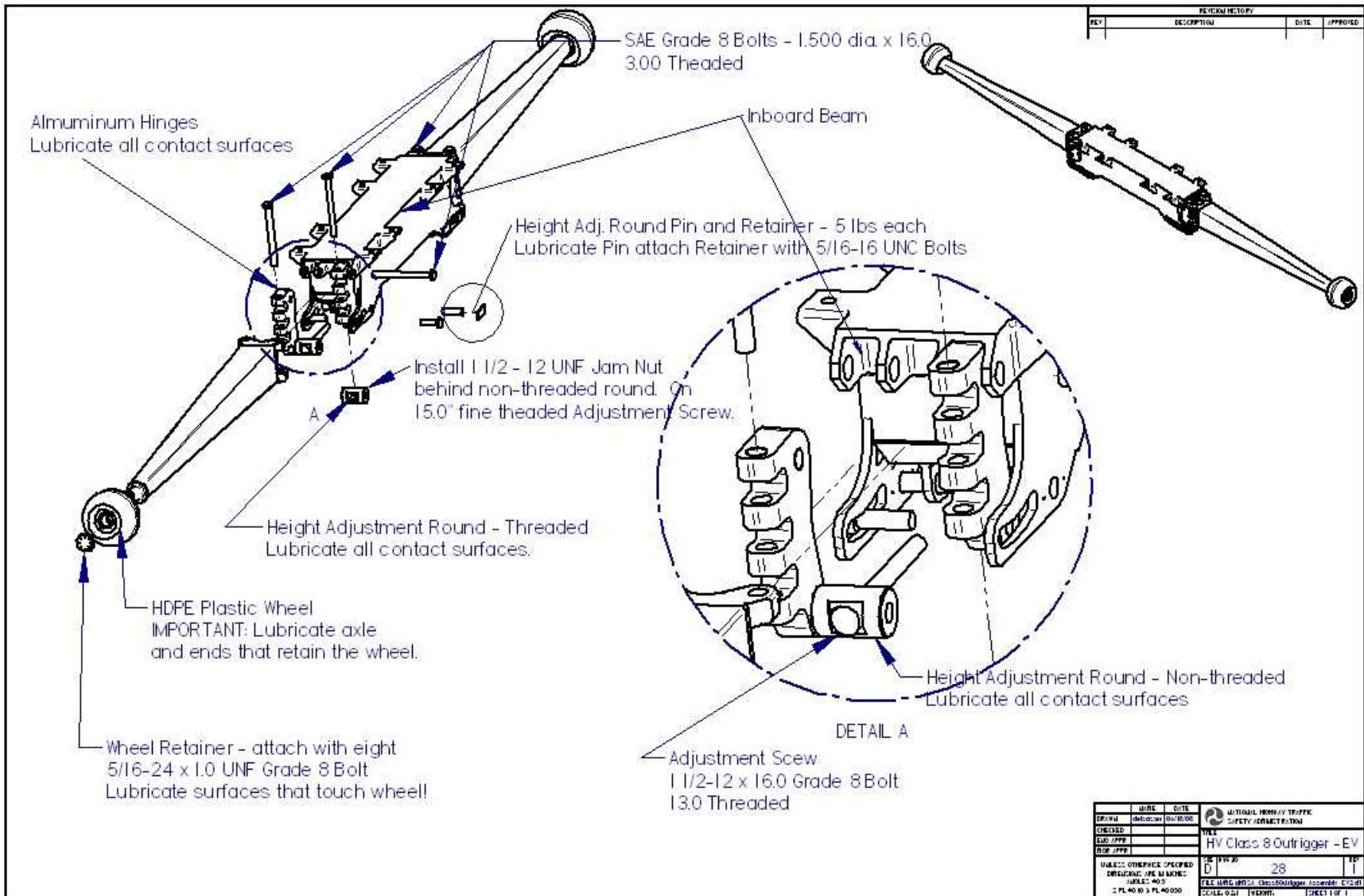

Figure 4.23:



Exploded view of the new outriggers. Gives notes on fasteners and lubrication of joints.

**Figure 4.24:**

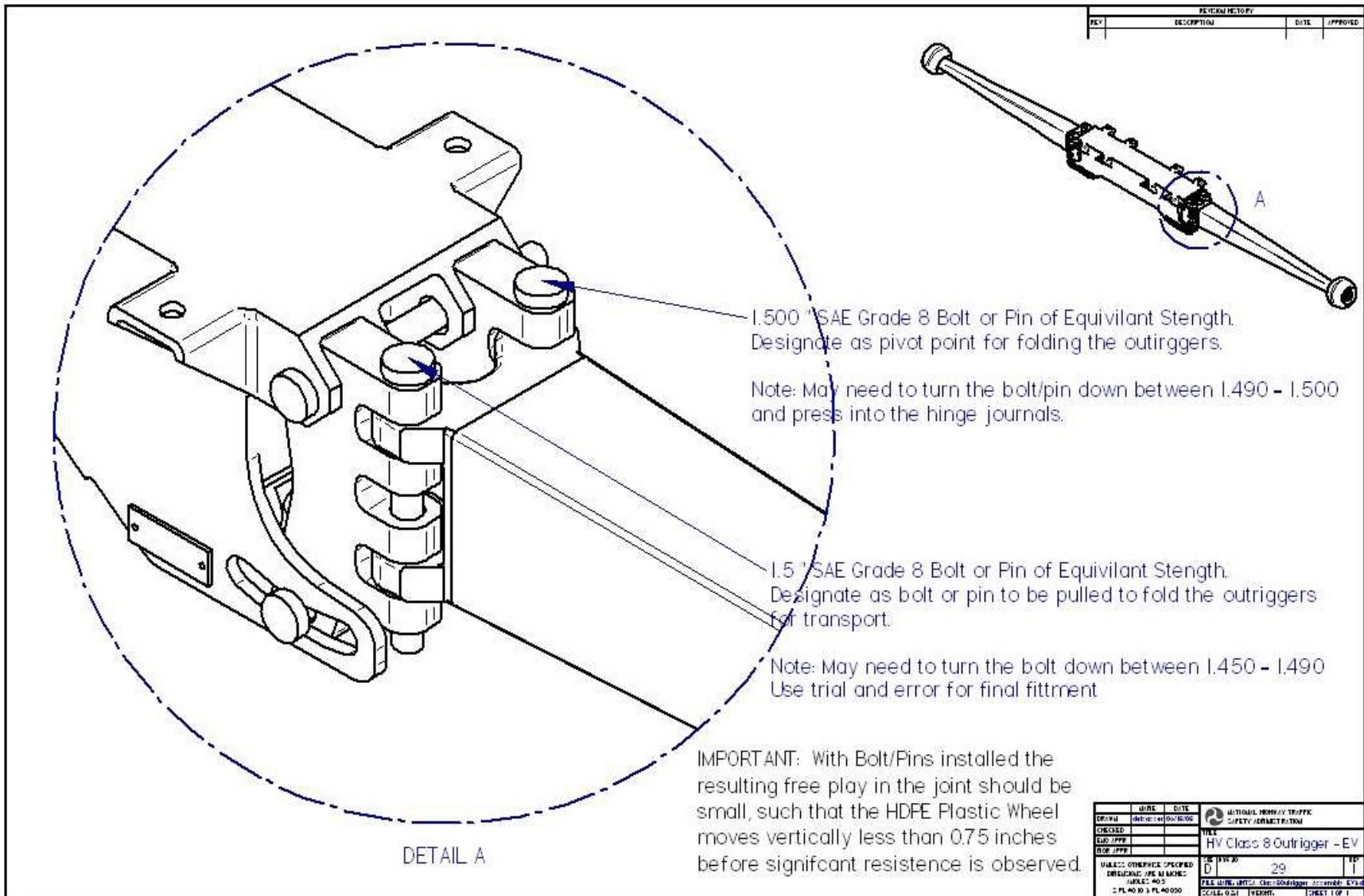

Figure 4.25:

More notes regarding the bolts and joint free play that can affect the height setting of the outrigger.

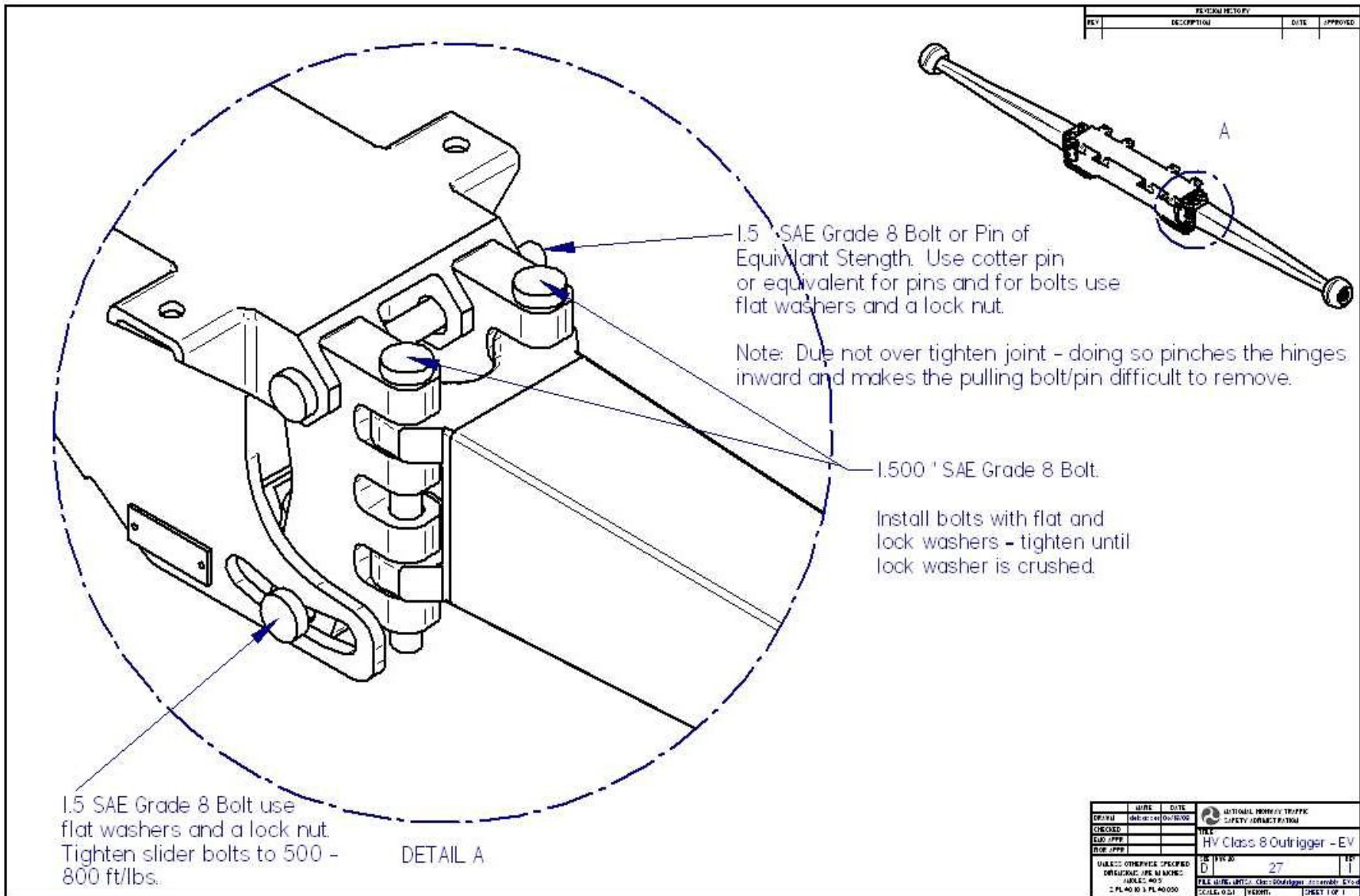

Figure 4.27:

Fastener tightening and torques settings used by NHTSA.

**Figure 4.28:**



## **5.0 NHTSA's EXPERIENCE WITH INSTALLATION and VALIDATION**

The following mounting applications and load validation tests are what NHTSA has done to date regarding the installation of the new outriggers. These examples and tests are not requirements or recommendations but are merely discussed to demonstrate what has been done and that test driver safety is the main focus behind the design of the new outriggers.

Specifically, this chapter covers NHTSA experience with mounting to flatbed and box van type trailers to validating outriggers and their mounts with static loads, setting the initial height of the HDPE wheel, and observations from the new outriggers initial dynamic tests.

### **5.1 Flatbeds and Box Vans**

For tractor/trailer combinations the new outriggers were mounted on the trailer. They were mounted near its C.G. (in the fore and aft direction of travel) for an evenly distributed load which is generally near the geometric center of the trailer. They were centered geometrically from side-to-side and were bolted up under the traditional trailer types (box van, flatbed, tanker...). Generally, the mounting points on the trailer will require reinforcement and special attention to how the outrigger loads are distributed into the trailer. Figures 5.1 and 5.2 show NHTSA's typical installation on flatbed and box van type trailers. Note that the outrigger is clamped and bolted to the main rails of the flatbed. For box van type trailers (which do not have main rails) two aluminum 10 ft. (4 in. x 6 in. x 0.25 in. wall) tubes were installed under the trailer to provide better distribution of the loads transferred from the outrigger striking the test surface.

Extra support mounts were fabricated for narrow frame rails to distribute the loads and take advantage of the support the outer edges of the trailer and outrigger mounts provide. Additional information about load distribution and weight capacities of trailers can be found in the specific trailers owners' manual.



**Figure 5.1:** Center: shows the main beam of the new outriggers mounted to a 28ft. flatbed type trailer. The main trailer rails are clamped on the outside and insides Upper Left: Shows the inside flanges of the trailer main rails were clamped and bolted to the outrigger adapter plate.



**Figure 5.2:** Center: Above shows the main beam mounted to a box van type trailer. The aluminum tubes between the outrigger and the bottom of the trailer were added to help distribute forces from the outrigger striking the test surface. Top Right: Inside view of the box van trailer; shows the clamp downs used to hold the aluminum tubes and outrigger to the bottom of the trailer.



## 5.2 Outrigger and Outrigger Mount Static Load Testing

Static loads were applied to the new outriggers after they were installed on a test vehicle prior to performing any dynamic maneuvers. This allowed researchers to evaluate the mounts and newly fabricated outrigger in a controlled manner. The setup used for the static testing is shown in Figure 5.3. From the figure, an overhead crane and tensile load cell are used to incrementally apply vertical loads to the axle shaft of one of the outriggers. The opposite outrigger is blocked to prevent the trailer from rolling and to allow the opposite outrigger to provide the reaction forces against those created by lifting with the crane. The crane was then used to apply force in 1,000 lb increments up to 10,000 lbs. All welds, bolts and joints were then inspected for any problems at the maximum load. This methodology was then used to evaluate the mounting brackets by removing the blocks under the outrigger on the opposite side. Loads applied to the outrigger to evaluate the mounts were varied with test vehicles. Vehicles given the freedom to rotate now required more space to perform the tests, so testing was terminated by the experimenter when conditions dictated that they should be.



**Figure 5.3:** Static outrigger and outrigger mount load rating check. Wheel on opposite side is blocked so that both Outboard Beams are evaluated at the same time. The blocks were then removed and a load was reapplied to the

outrigger to evaluate the mounts. Setup used an overhead crane and tensile load cell to measure the force applied to the outriggers.

### 5.3 Wheel Height Adjustment and Initial Setting

Outrigger wheel height is controlled by the adjustment screws under the Inboard Beam. By turning the adjustment screw, the wheels move up or down. By moving the wheel up or down, the allowable roll angle of the vehicle is either increased or decreased. NHTSA initially sets the wheel height between 10 and 11 inches. This usually results in an allowable roll angle of approximately 7.5 – 8.5 degrees as measured from the ground plane. Typical outrigger contact was observed when the wheels<sup>8</sup> of the test vehicle were between 2 – 6 inches. If the outrigger wheel made contact with the test surface prior to wheel lift then the outriggers were adjusted up in 1.0 inch increments. These adjustments were made until 2 – 6 inches of wheel lift were observed before the outriggers arrested the roll motion.

To adjust the wheel height, the slider bolts, jam nut and bolts holding the Threaded Adjustment Round were loosened to allow the joints to slide. Then by turning the adjustment screw and/or jam nut the outrigger height was set. Once desired height was set, all fasteners were retightened. The slider bolts were set to 500 ft-lbs or greater and the rest of the fasteners were tightened until the lock washers were crushed.

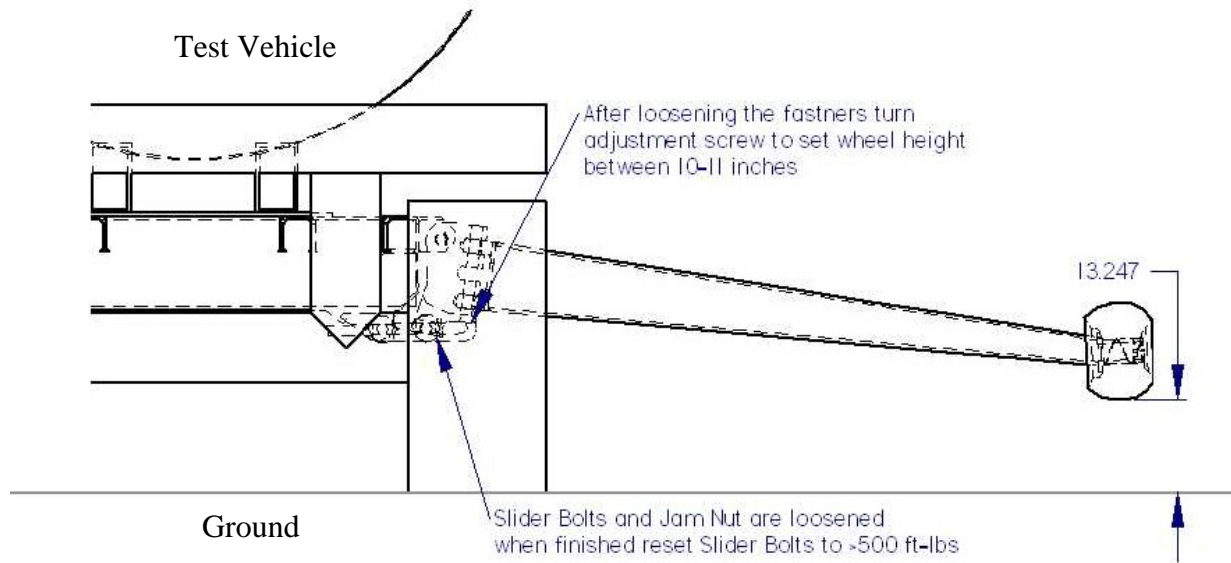

**Figure 5.4:** Diagram shows details on setting initial outrigger wheel height to between 10-11 inches.

### 5.4 Observations From Initial Dynamic Evaluation

Initially, the new outriggers were mounted to a tractor/trailer combination loaded to 80k lbs in which the C.G. of the load was elevated (~81 inches) to lower the roll stability of the test vehicle.

<sup>8</sup> Wheels in this instance are referring to the trailer wheels that are traveling through the inner portion of a curve and have a decreasing normal load due to weight transfer to the tires in the outer portion of the curve.

Initial dynamic tests conducted with the new outriggers have shown them to be durable and easy to use. Of particular interest, was the plastic outrigger wheels response to initial dynamic rolling loads. Table 5.1 presents information about the first 14 maneuvers in which the outrigger wheel struck the testing surface. Besides the maneuver, it provides the figure number showing the wear pattern of the wheel after the event and the maneuver entrance speed for which it was observed. Figures 5.5-5.7 show the wear on the wheel after the first, seventh and fourteenth observances of outrigger wheel to test surface contact. From the figures, the wear pattern shows that the contact patch is widening with each observed contact. The largest amount of wear to the wheel was observed between the first and seventh contacts. However, there does not appear to be a large amount of wear with respect to change in the overall diameter ( $\sim 1/32$  inch) of the wheel.

**Table 5.1:** Table of first 14 observed outrigger contact observations with a tractor/trailer combination loaded to 80k lbs (axle loading front to rear was 12k(front), 34k(drive tandem), 34k(trailer tandem)) with a raised C.G.

Test	Maneuver	Figure Showing Wear	Entrance Speed (mph)
1	Constant Radius	Figure 5.5	29
2	J-Turn		42
3	J-Turn		42
4	J-Turn		41
5	J-Turn		41
6	J-Turn		32
7	J-Turn	Figure 5.6	31
8	J-Turn		31
9	J-Turn		40
10	J-Turn		38
11	J-Turn		36
12	J-Turn		36
13	J-Turn		28
14	J-Turn	Figure 5.7	28



**Figure 5.5:** Wear after the first contact between wheel and test surface. **Figure 5.6:** Wear after seven strikes between wheel and test surface. Diameter change is estimated at ~1/32 inch or less. **Figure 5.7:** Wear after 14 strikes observed between wheel and test surface.

## REFERENCES

- “Steady-State Directional Control Test Procedures For Passenger Cars and Light Trucks,” Society of Automotive Engineers, Inc., SAE Surface Vehicle Recommended Practice J266, January 1996.
- Forkenbrock, G.J., Elsasser, D. “Effects of Outriggers on Dynamic Rollover Resistance Maneuvers: Results From NHTSA’s Light Vehicle Rollover Research Program,” Society of Automotive Engineers, Inc., Paper Number 2003-01-1011, 2003.
- Winkler, C. B., Bogard, S. E., Karamihas, S. M., University of Michigan, Ann Arbor, Transportation Research Institute, “Parameter Measurements of a Highway Tractor and Semitrailer,” University of Michigan, Transportation Research Institute, Report Number: UMTRI-95-47, 1995.
- Hamrock, B.J., Jacobson, B.O., Schmid, S.R., “Fundamentals of Machine Elements,” WCB/McGraw-Hill, 1999.
- Meriam, J.L., Kraige L.G., “Engineering Mechanics Dynamics, Fourth Edition,” John Wiley & Sons, Inc., 1997.
- Hibbeler, R.C., “Mechanics of Materials, Fourth Edition,” Prentice Hall, Inc., 2000.
- Oberg, E., Industrial Press, “Machinery’s Handbook 26, Twenty-Sixth Edition,” Industrial Press, Inc., New York, 2000.

# APPENDIX

## Outboard Beam Part Drawings

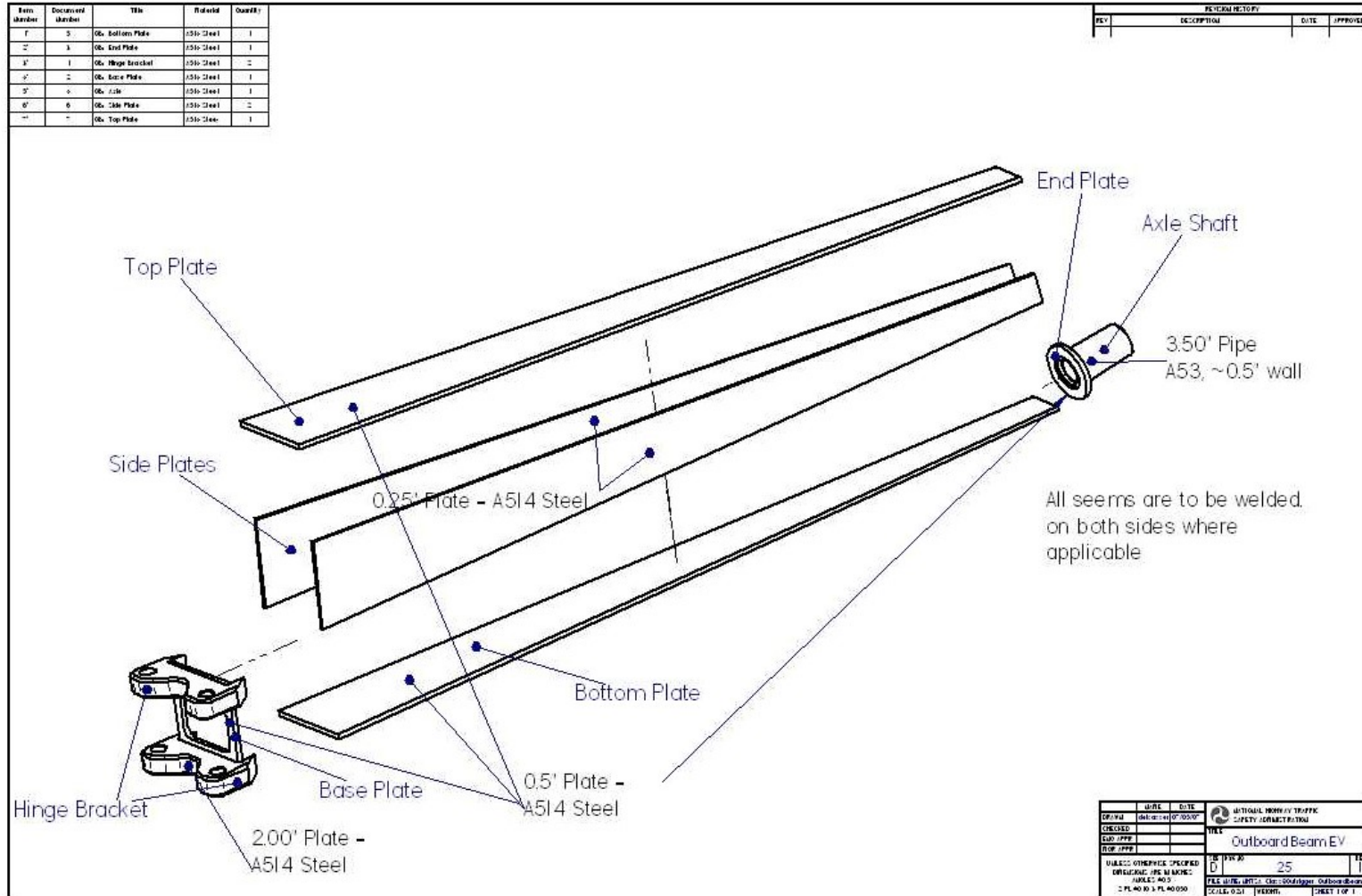

**Figure A.1:** Assembly details of the Outboard Beam of the new NHTSA class 8 outriggers. Labels on the parts are used in subsequent Outboard Beam assembly drawings.

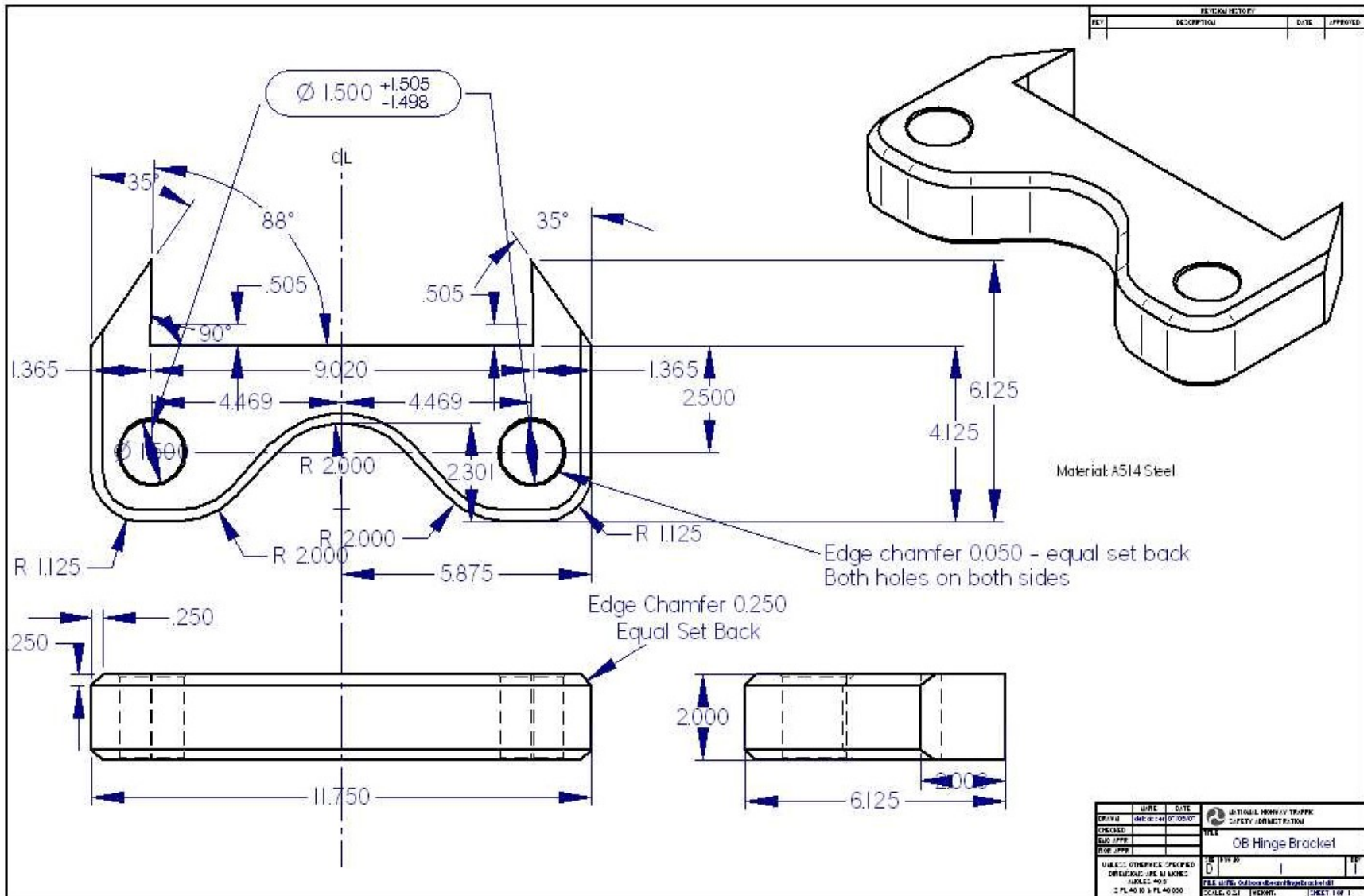

REVISION HISTORY			
REV	DESCRIPTION	DATE	APPROVED

DESIGN	DATE	 NATIONAL HEAVY DUTY TRUCK SAFETY CONSORTIUM	OB Hinge Bracket
CHECKED			
ED: JFF			
DR: JFF			
MAKE: OTHERWISE SPECIFIED ORIGINAL: JRS: B: MHC: JPK: A03 2-PL: 40-10-3-PL: 40-000		REV: 01 1	SHEET 1 OF 1

**Figure A.2:** Draft of Hinge Bracket for the Outboard Beams. Note: Quantity needed is shown in Figure A1, double the quantity to build a complete set of outriggers.

outriggers.

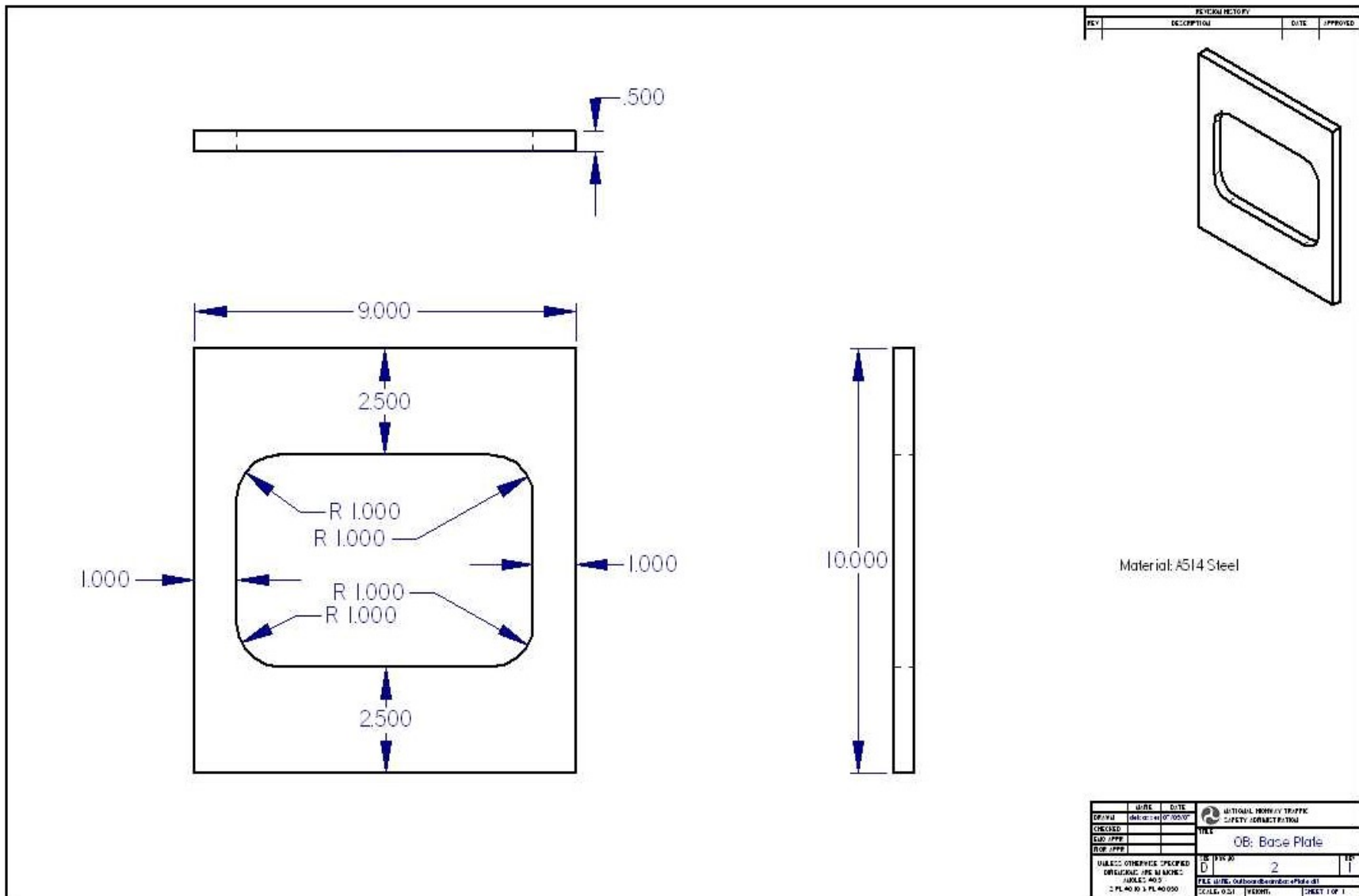

**Figure A.3:** Draft of Base Plate for the Outboard Beams. Note: Quantity needed is shown in Figure A1, double the quantity to build a complete set of



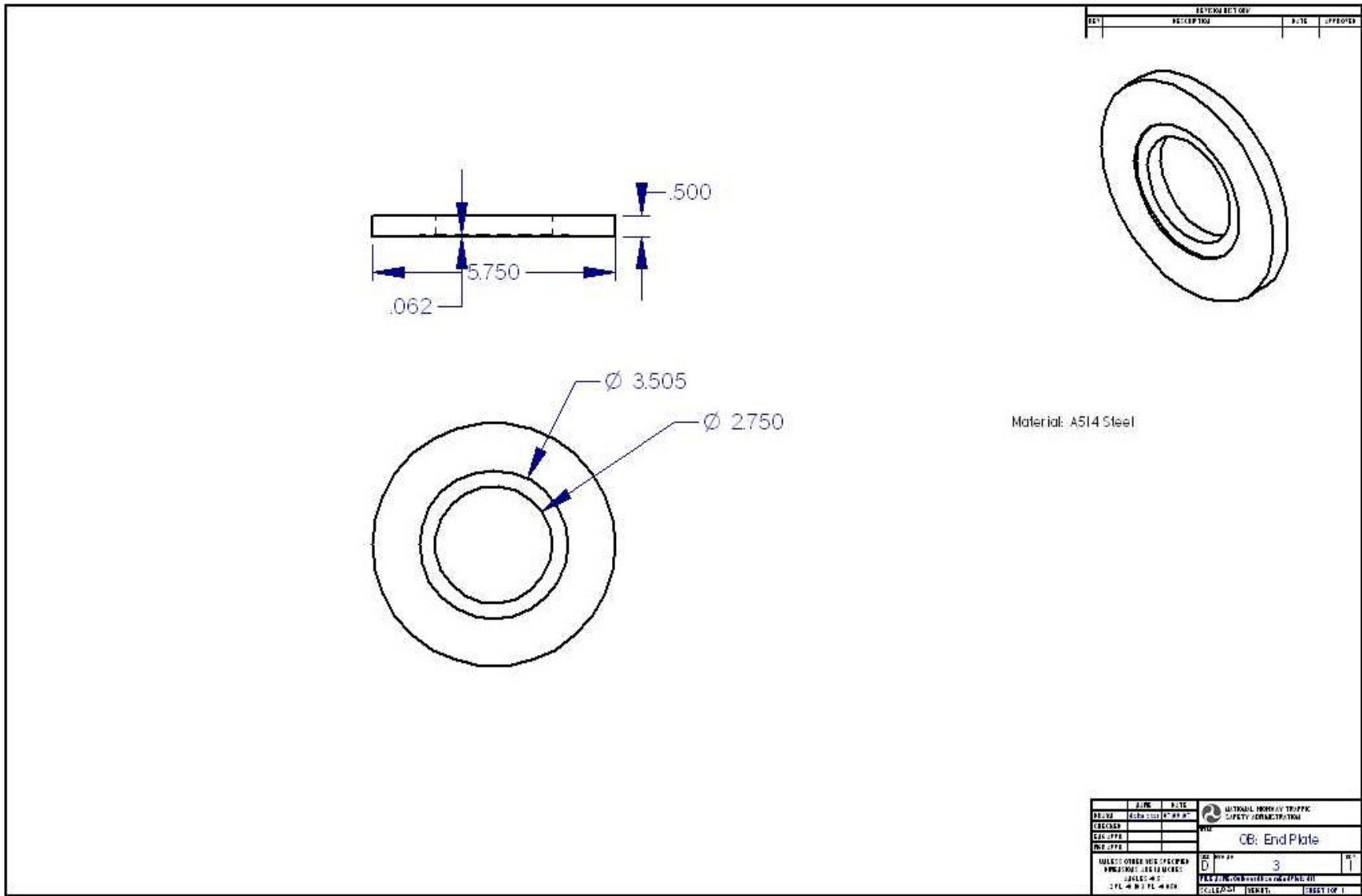

outriggers.

**Figure A.4:** Draft of End Plate for the Outboard Beams. Note: Quantity needed is shown in Figure A1, double the quantity to build a complete set of

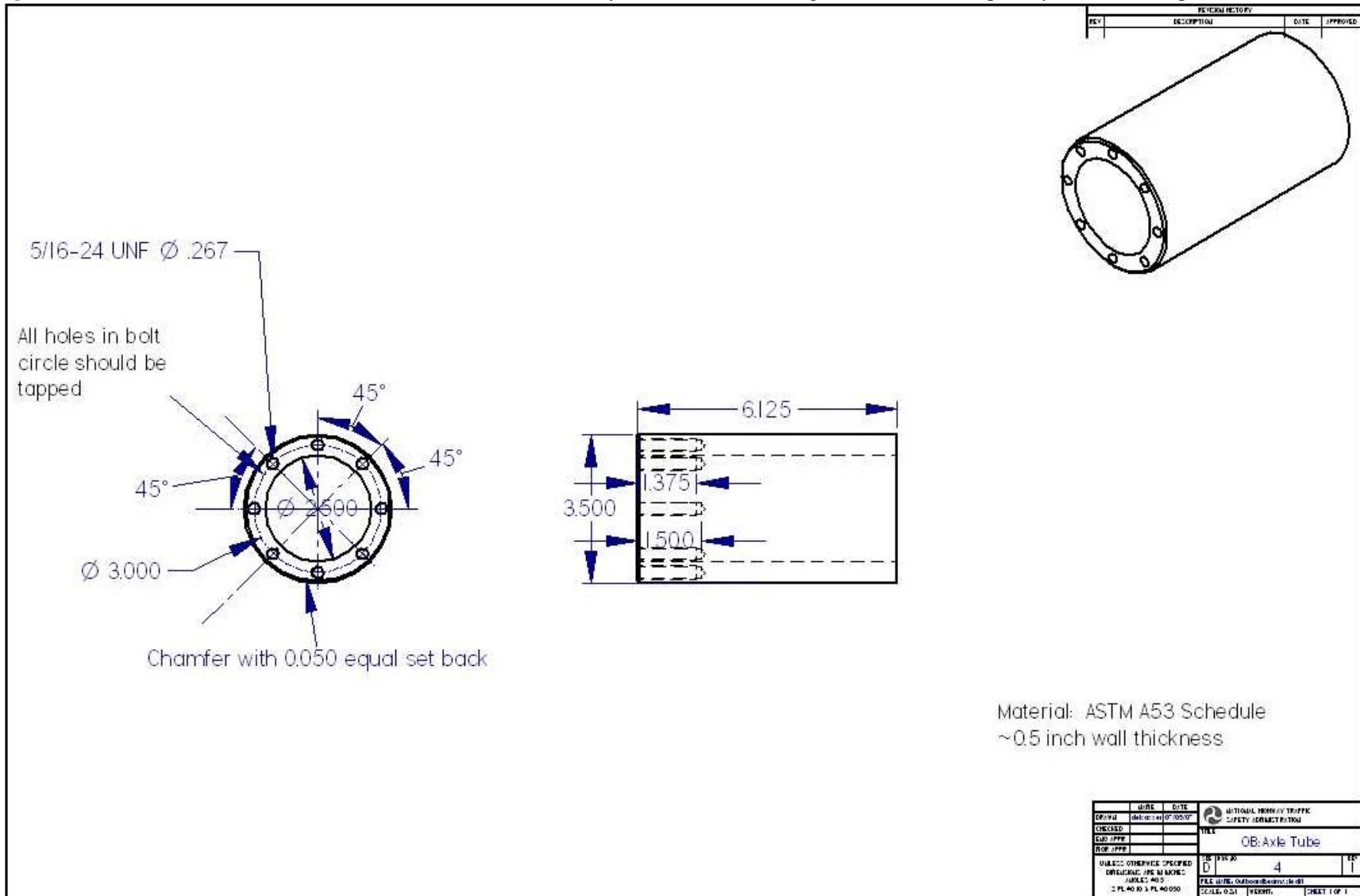

**Figure A.5:** Draft of Axle Tube for the Outboard Beams. Note: Quantity needed is shown in Figure A1, double the quantity to build a complete set of

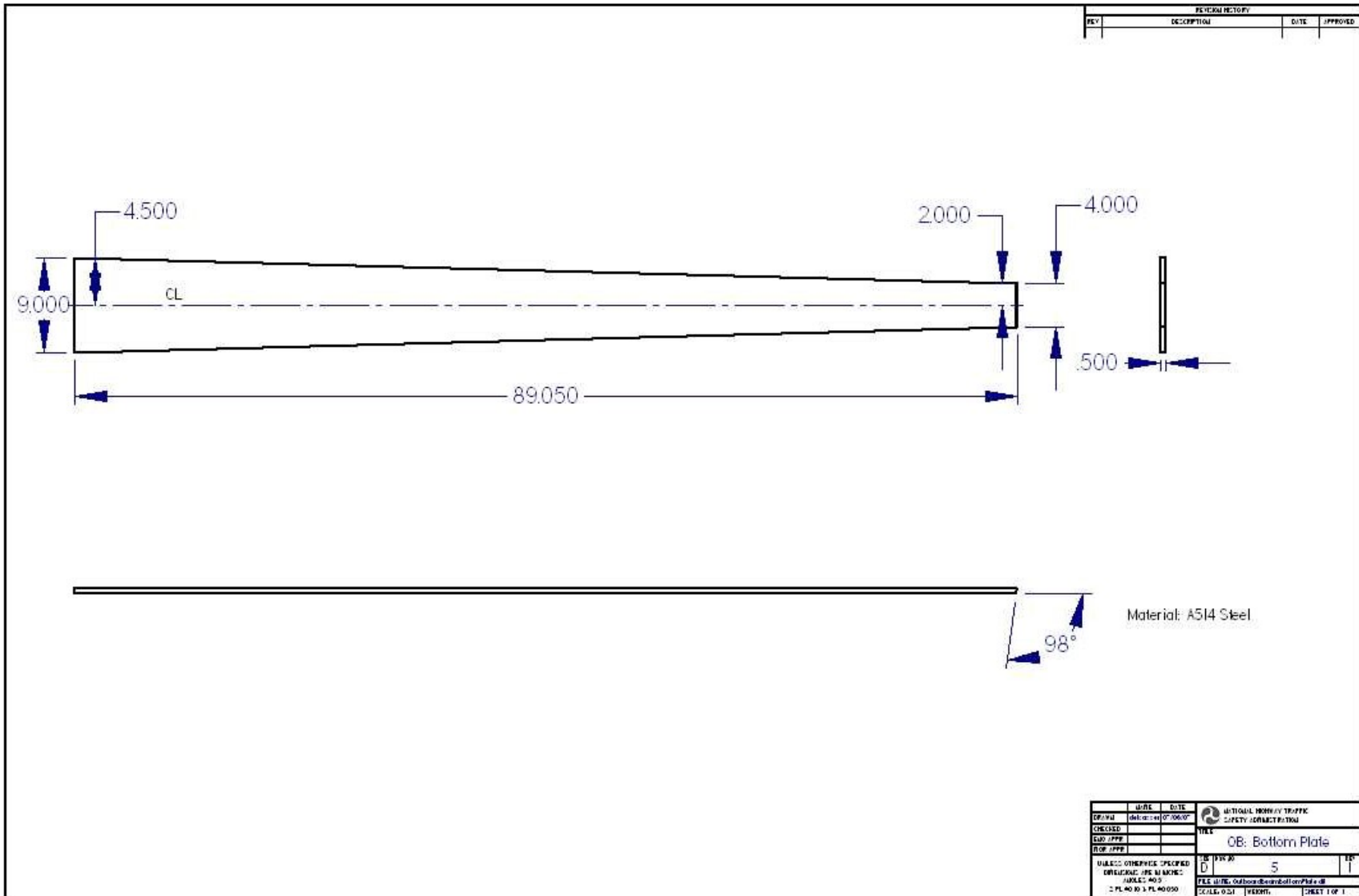

REVISION HISTORY			
REV	DESCRIPTION	DATE	APPROVED

DATE	DATE	 MICHIGAN NON-HIGHWAY TRAFFIC SAFETY CONNECTION
DRWING	DATE	
CHECKED		TITLE <b>OB: Bottom Plate</b>
DATE APPR		SHEET NO. 5
DATE APPR		FILE NAME: obbottomplate.dwg SCALE: 0.25 SHEET: 1 OF 1

outriggers.

**Figure A.6:** Draft of Bottom Plate for the Outboard Beams. Note: Quantity needed is shown in Figure A1, double the quantity to build a complete set of outriggers.



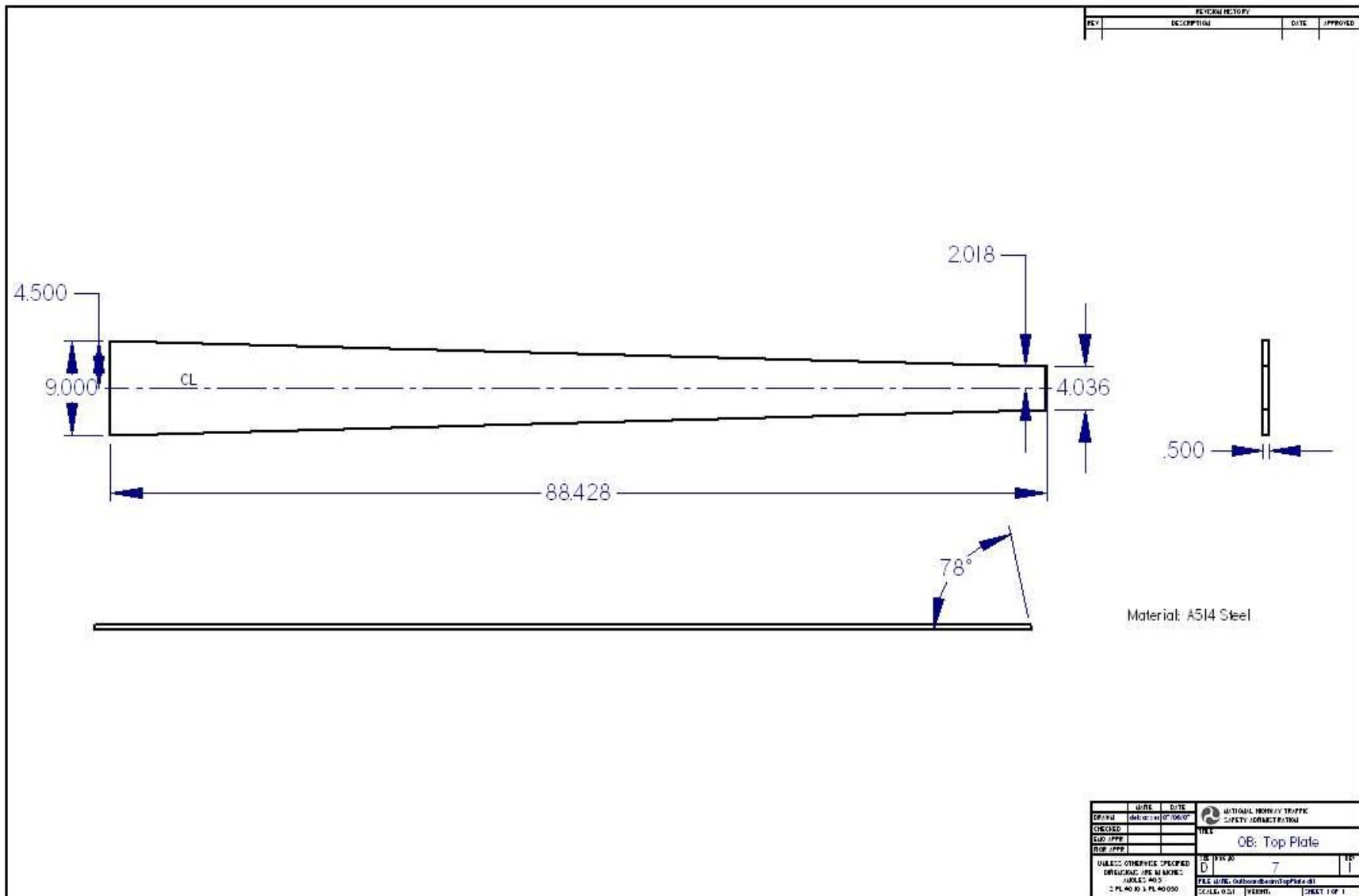

**Figure A.8:** Draft of Top Plate for the Outboard Beams. Note: Quantity needed is shown in Figure A1, double the quantity to build a complete set of outriggers.



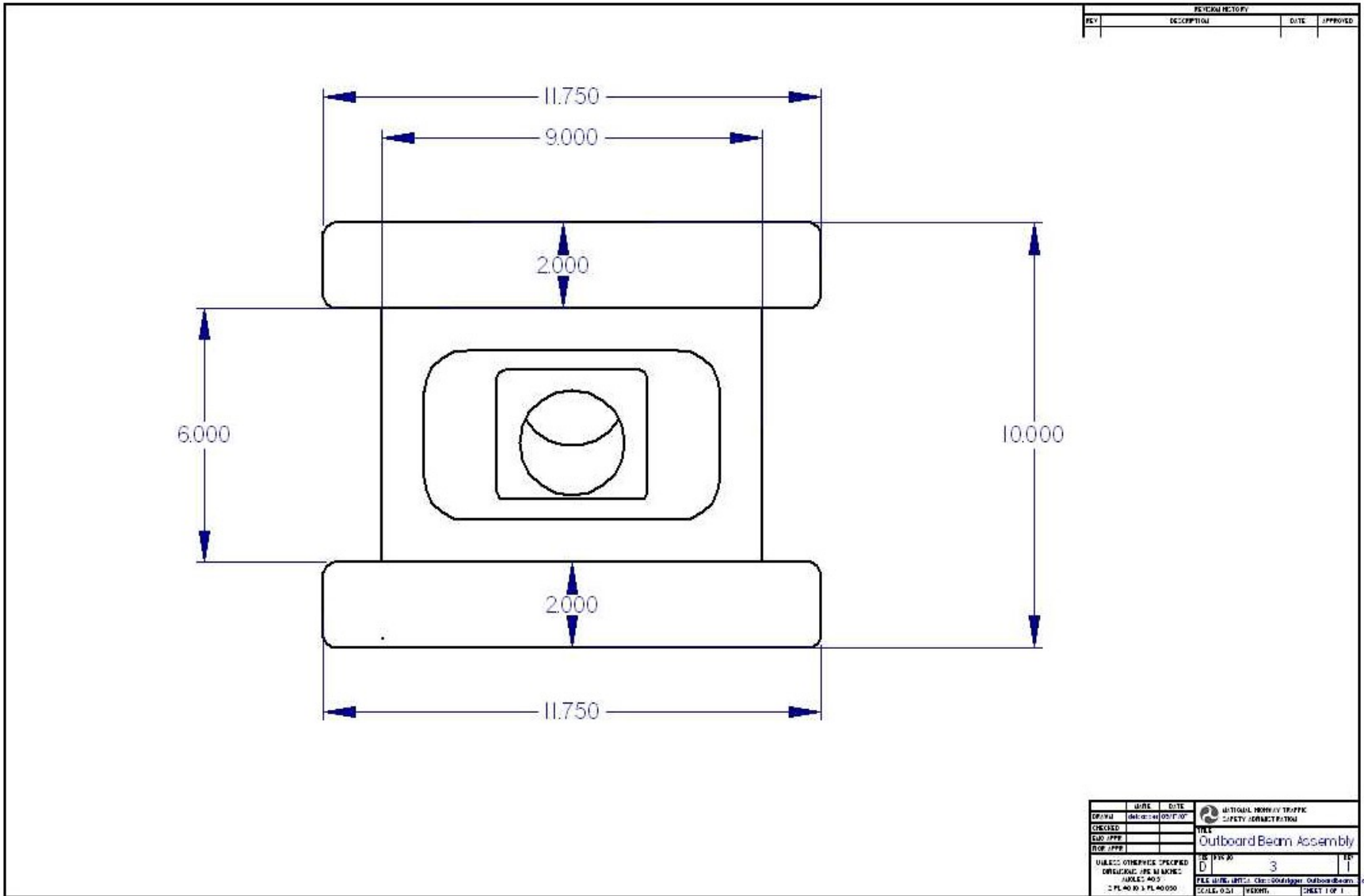

Figure A.10: End view (Hinge Bracket placement) draft of the Outboard Beam assembly.



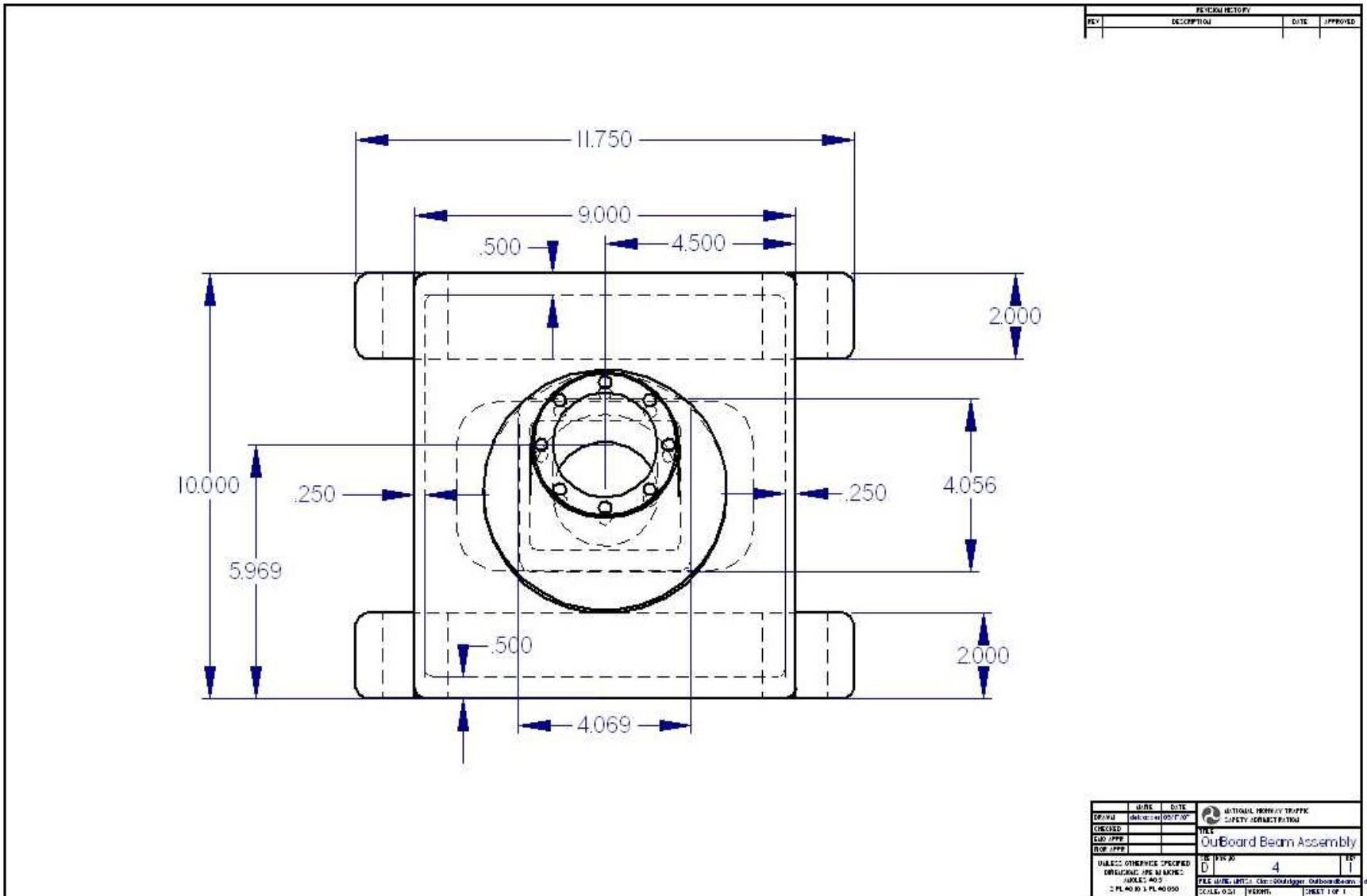

Figure A.11: End view (Axle and End Plate placement) draft of the Outboard Beam assembly.

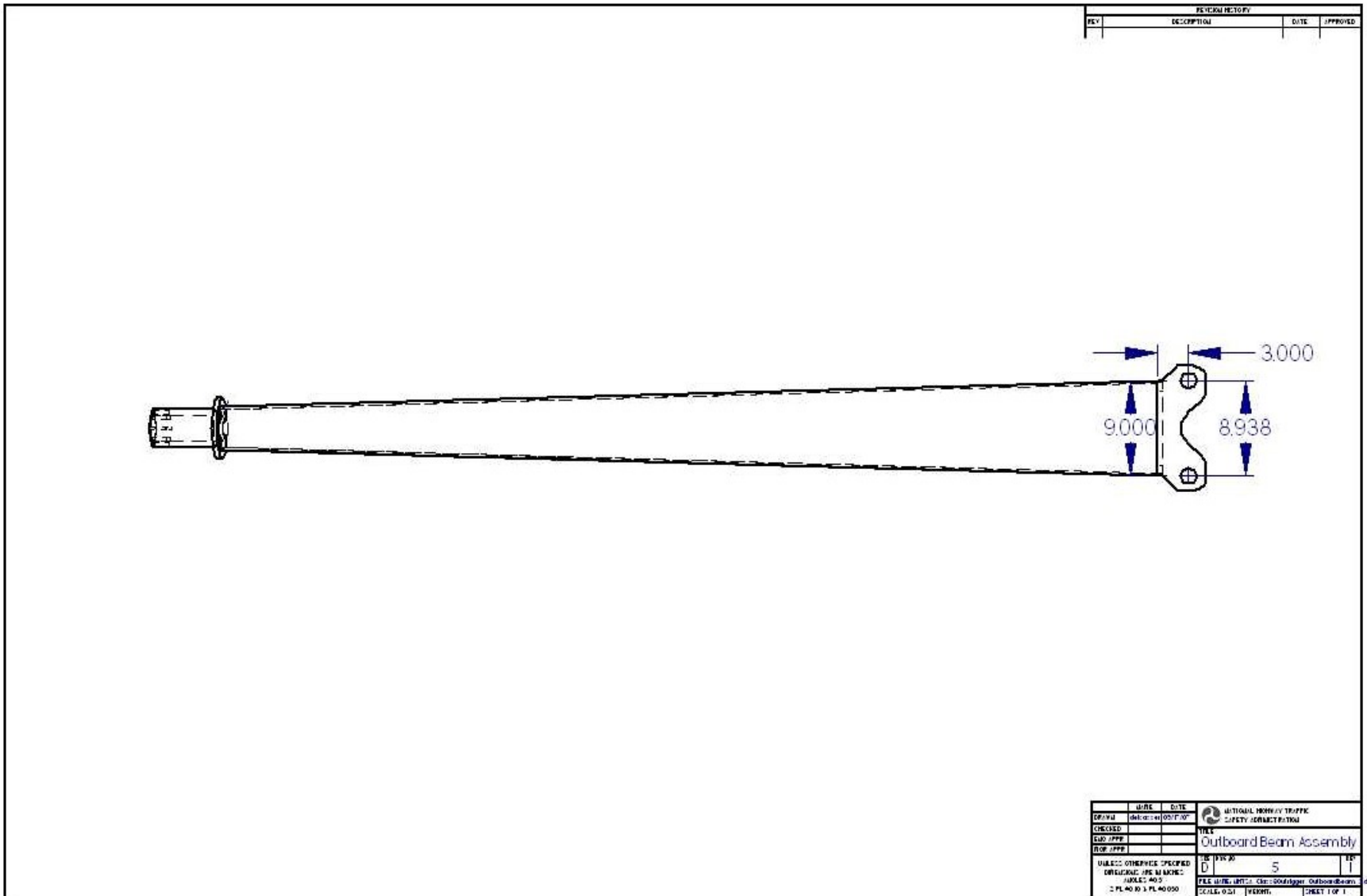

Figure A.12: Top view draft of the Outboard Beam assembly.



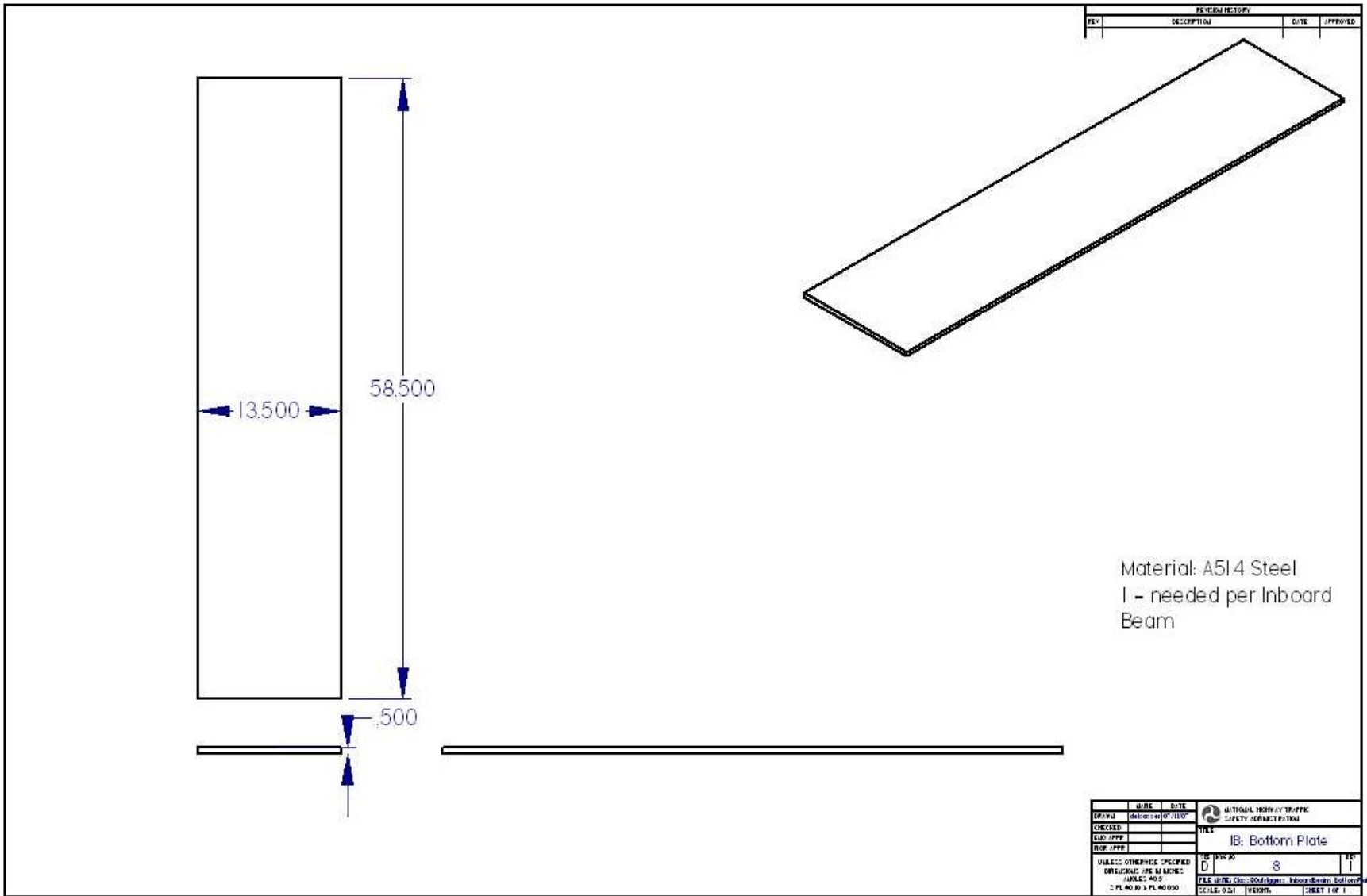

Figure A.14: Draft of Bottom Plate for the Inboard Beam.



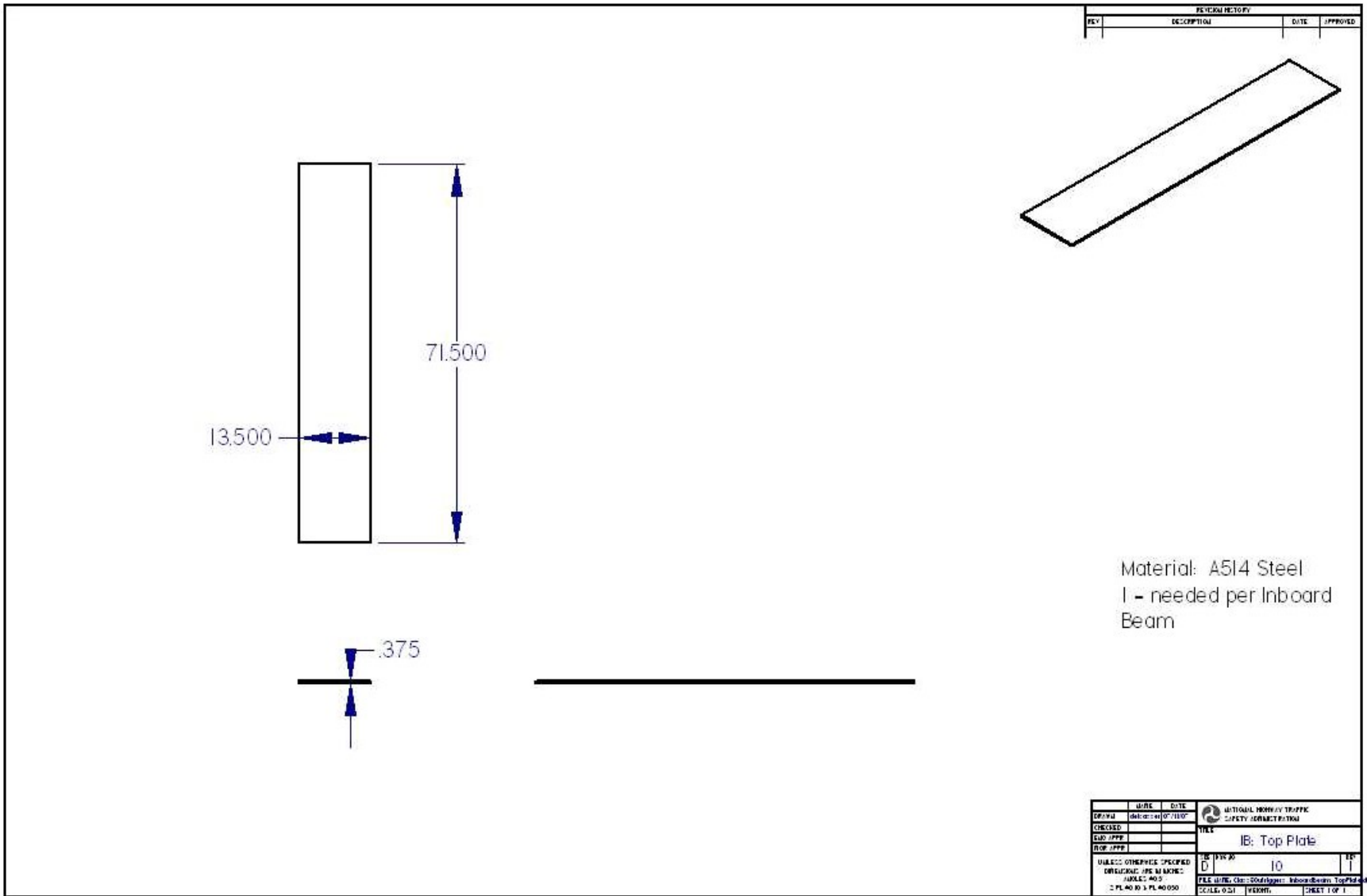

Figure A.16: Draft of Top Plate for the Inboard Beam.

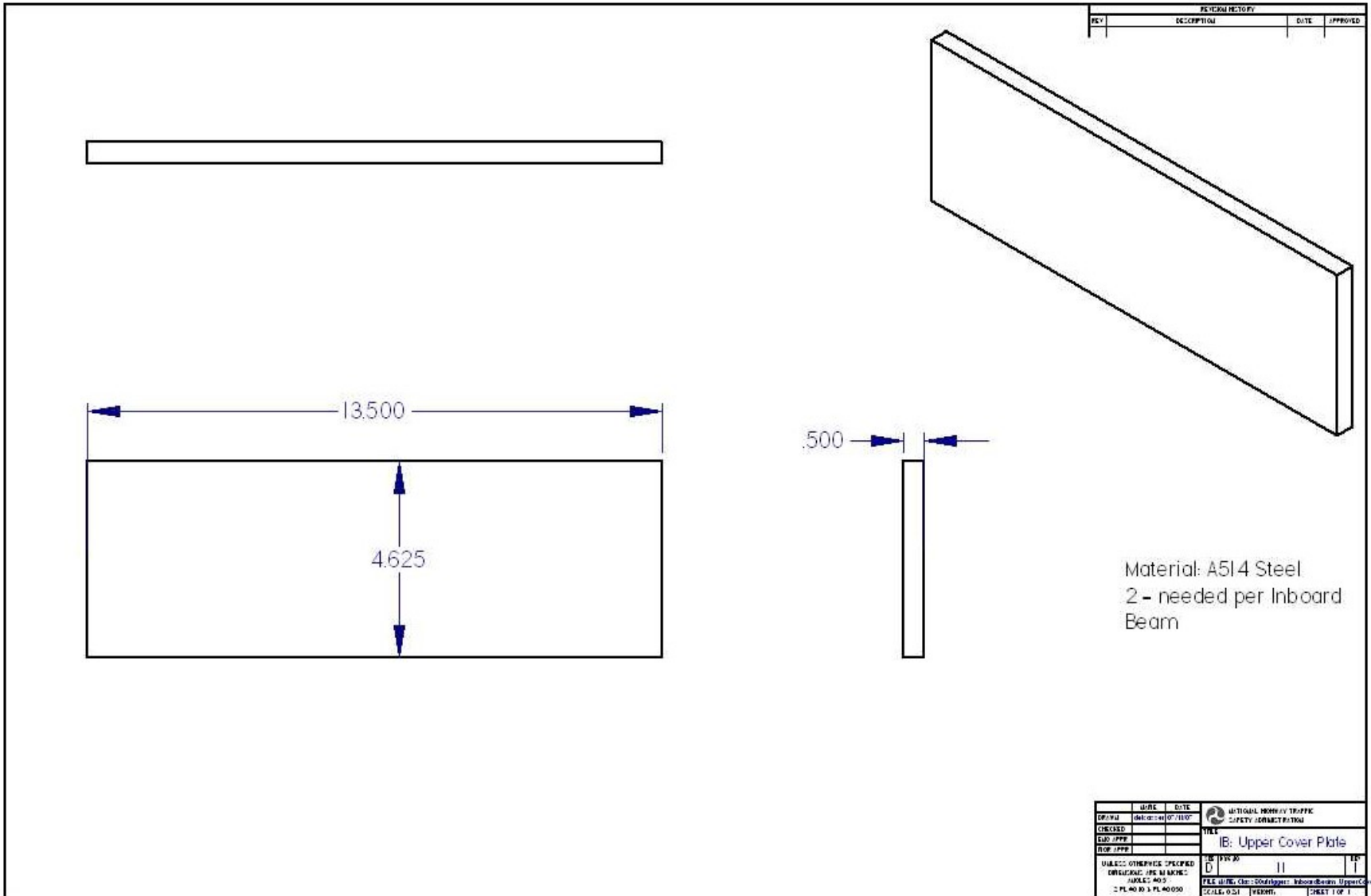

Figure A.17: Draft of Upper Cover Plate for the Inboard Beam.











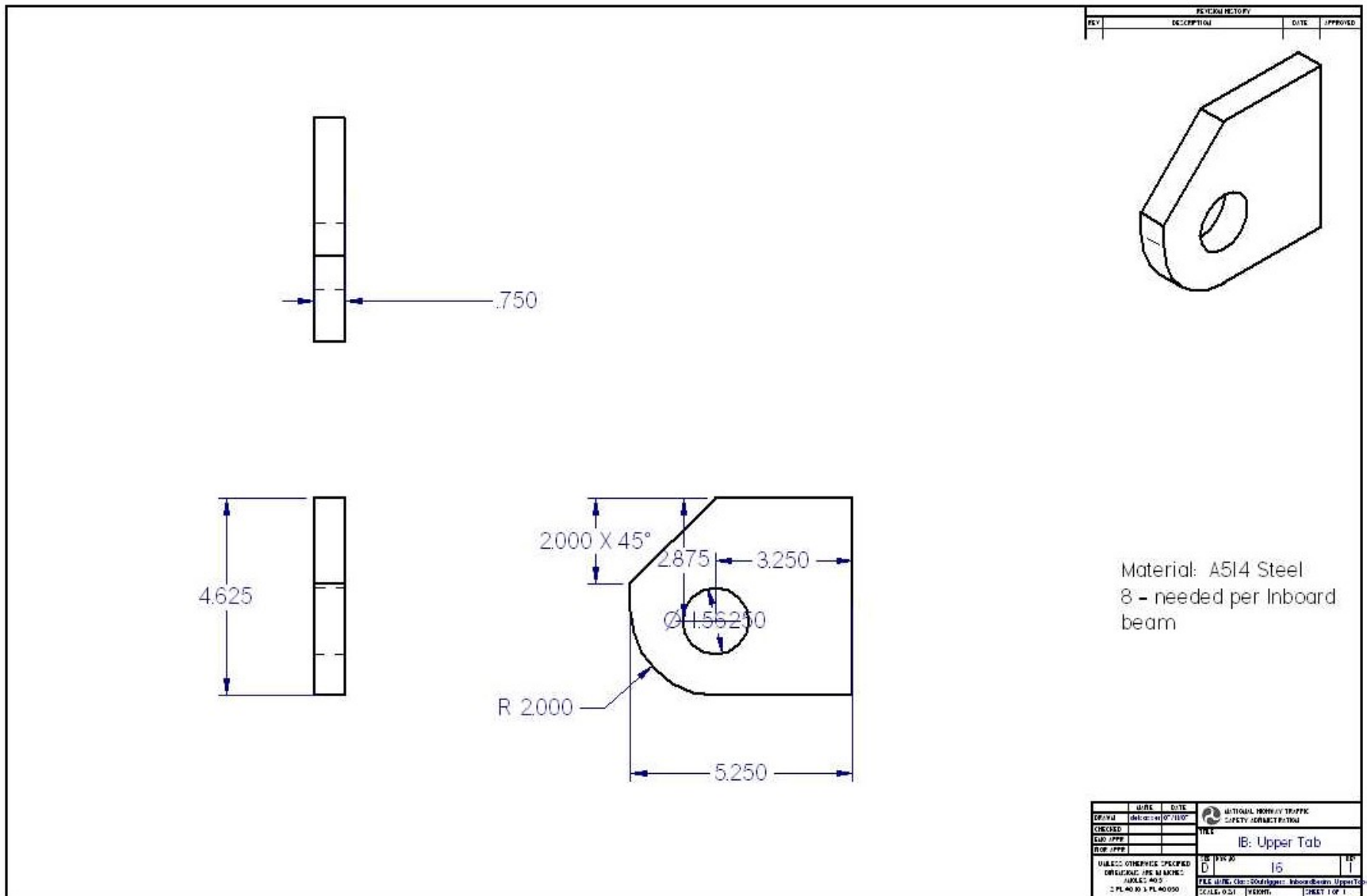
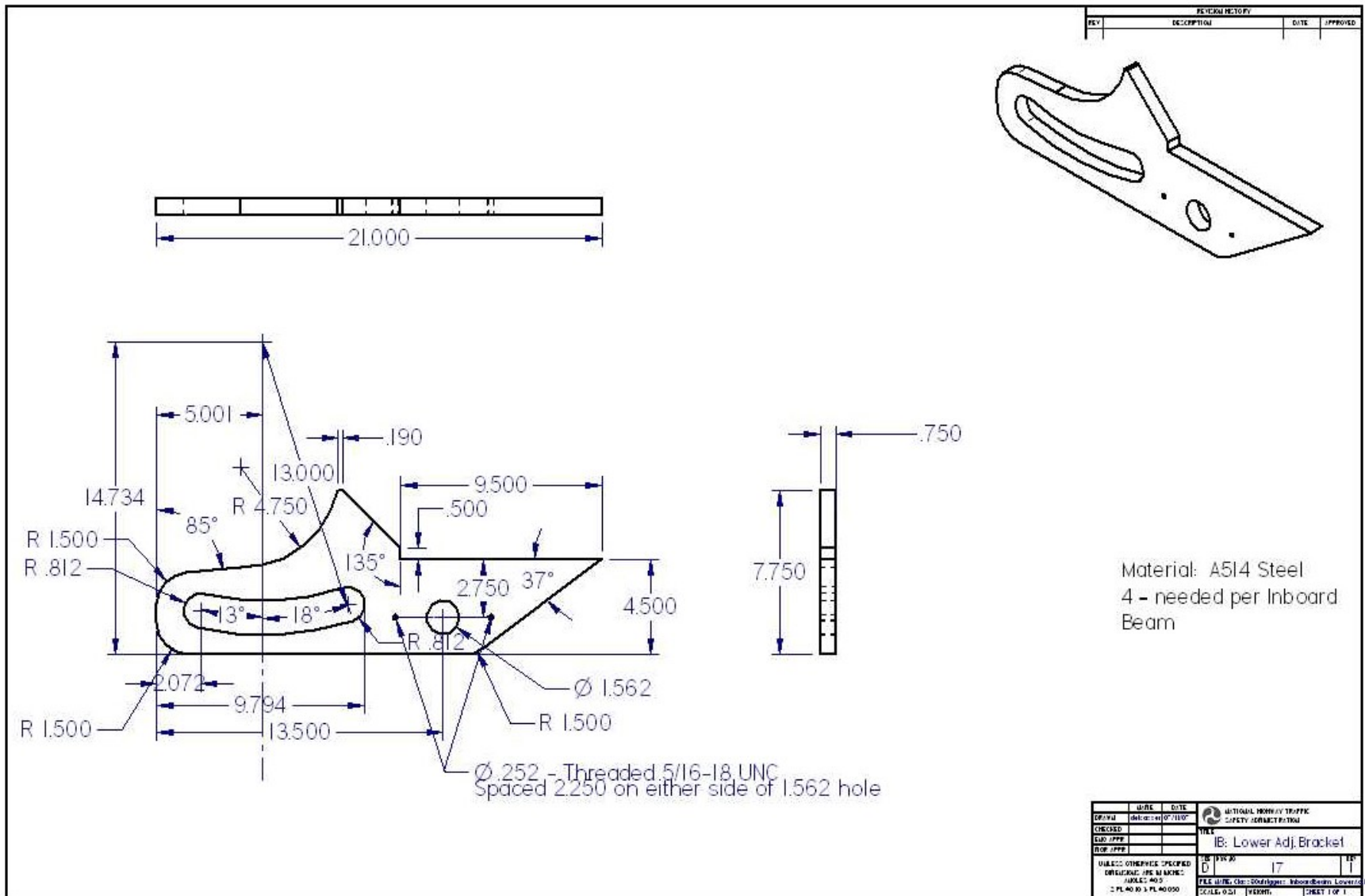

Figure A.22: Draft of Upper Tab for the Inboard Beam.



**Figure A.23:** Draft of Lower Adjustment Bracket for the Inboard Beam.

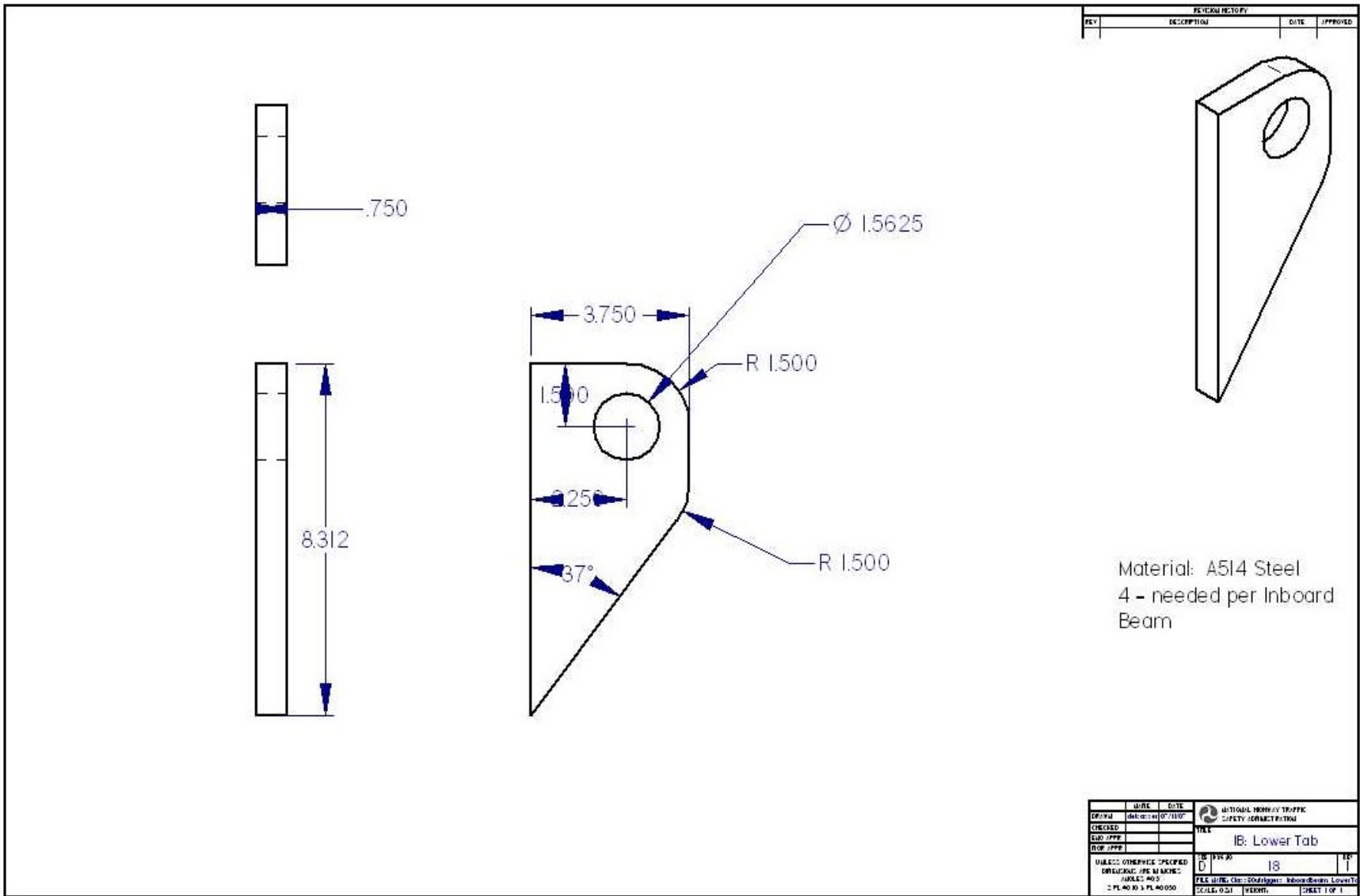

Figure A.24: Draft of Lower Tab for the Inboard Beam.

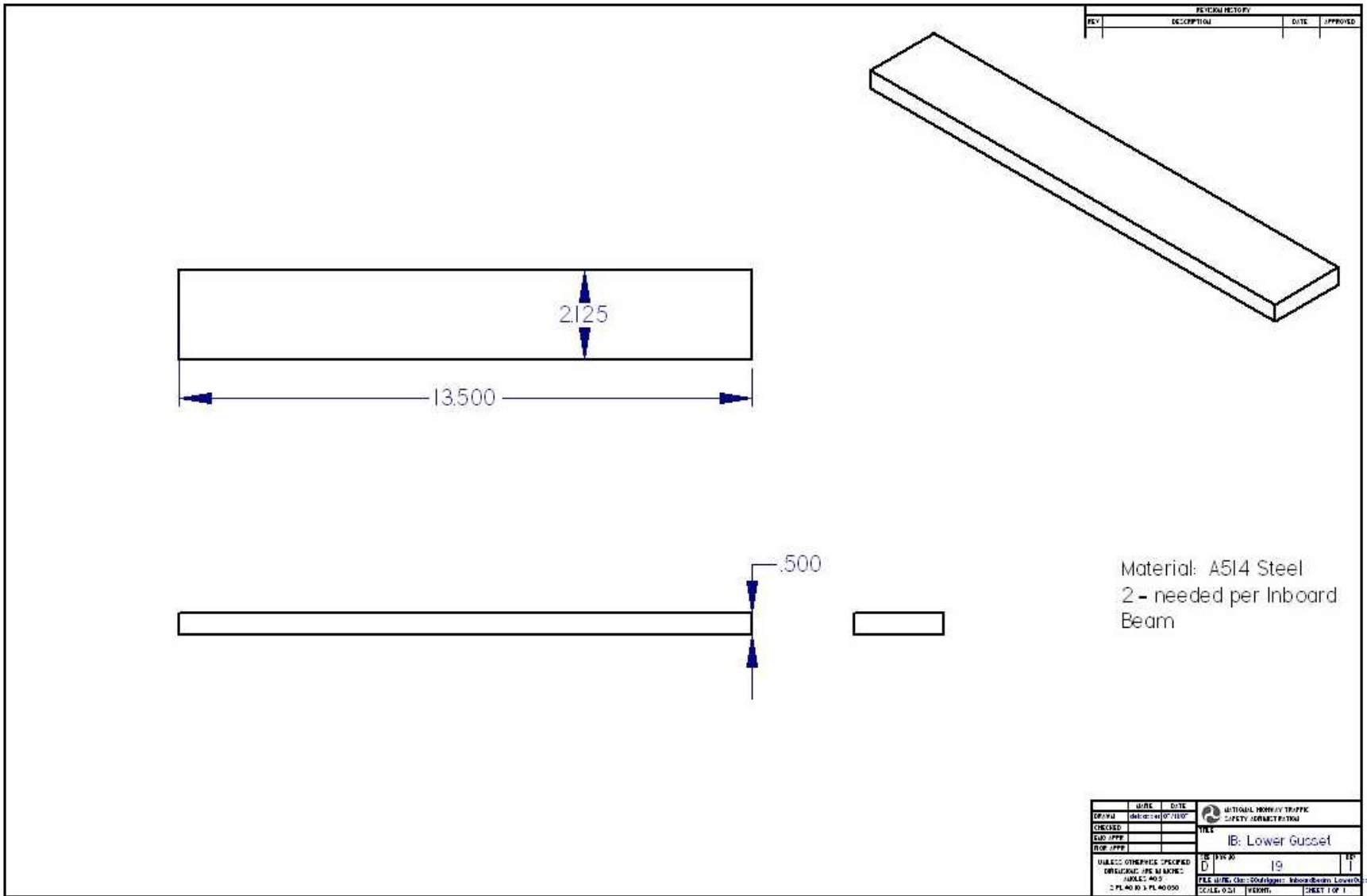

Figure A.25: Draft of Lower Gusset for the Inboard Beam.

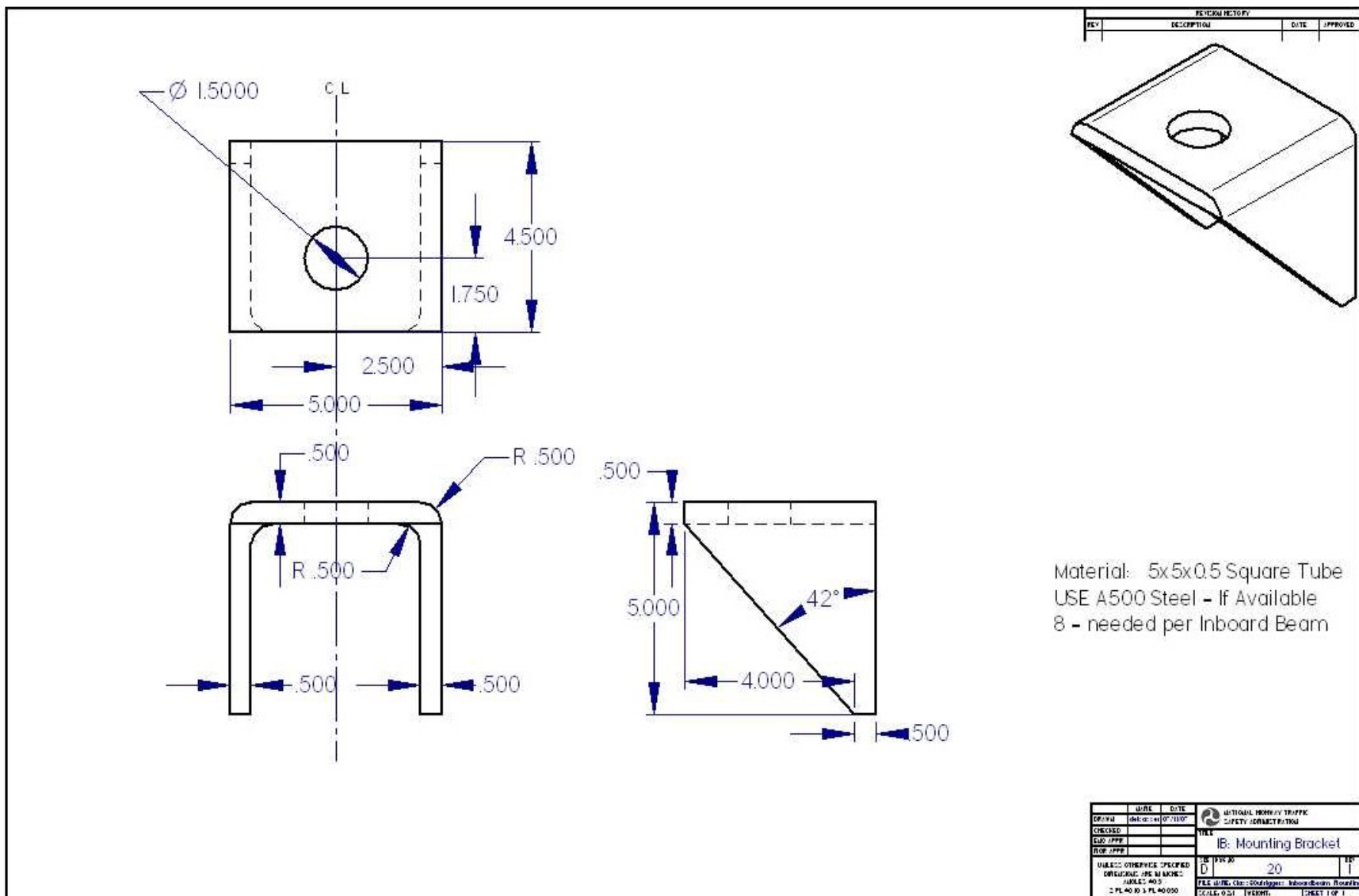

Figure A.26: Draft of Mounting Bracket for the Inboard Beam.







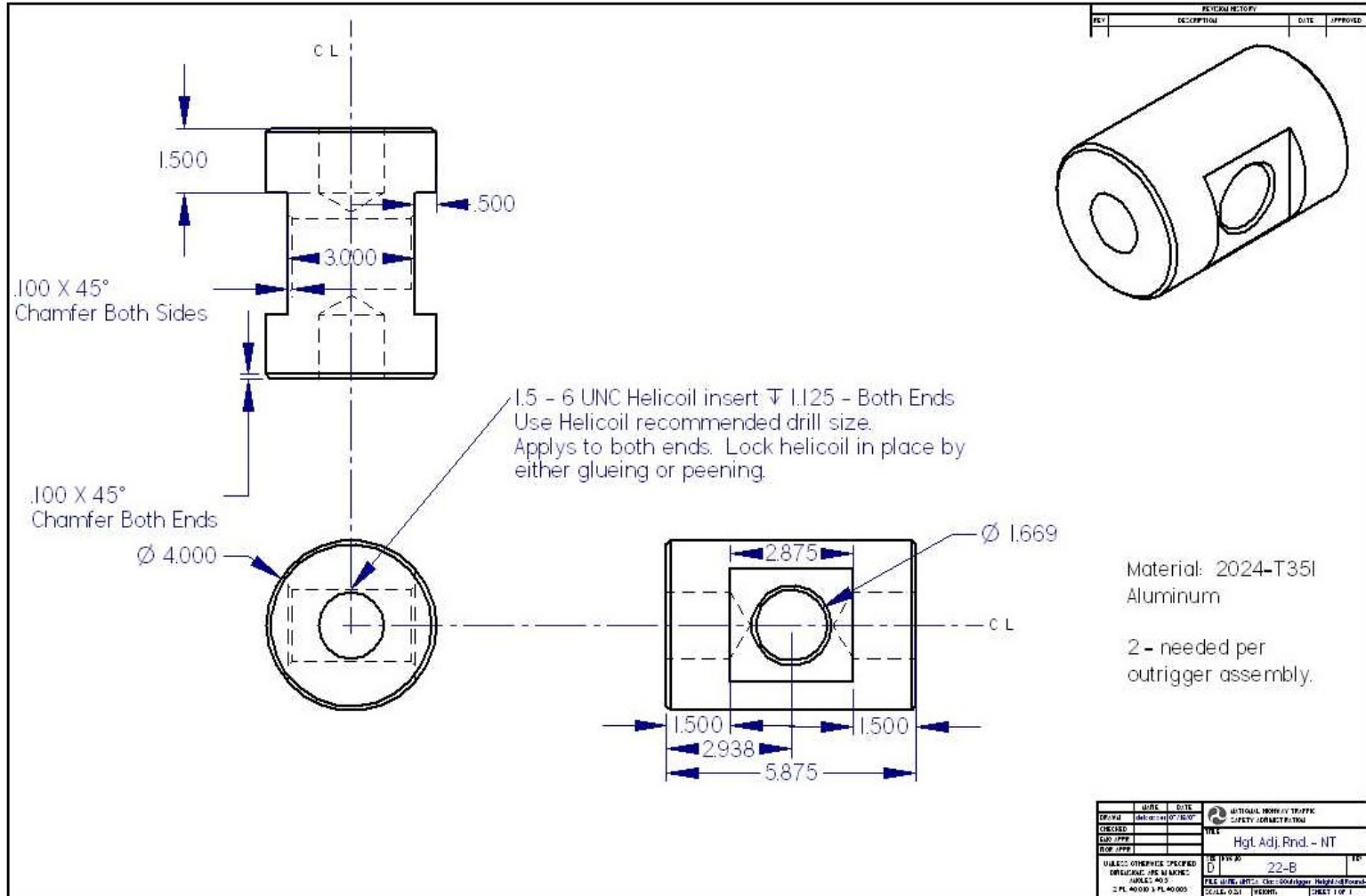

Figure A.29: Draft of Non-Threaded Height Adjustment Round.

# Wheel Retainer Drawing

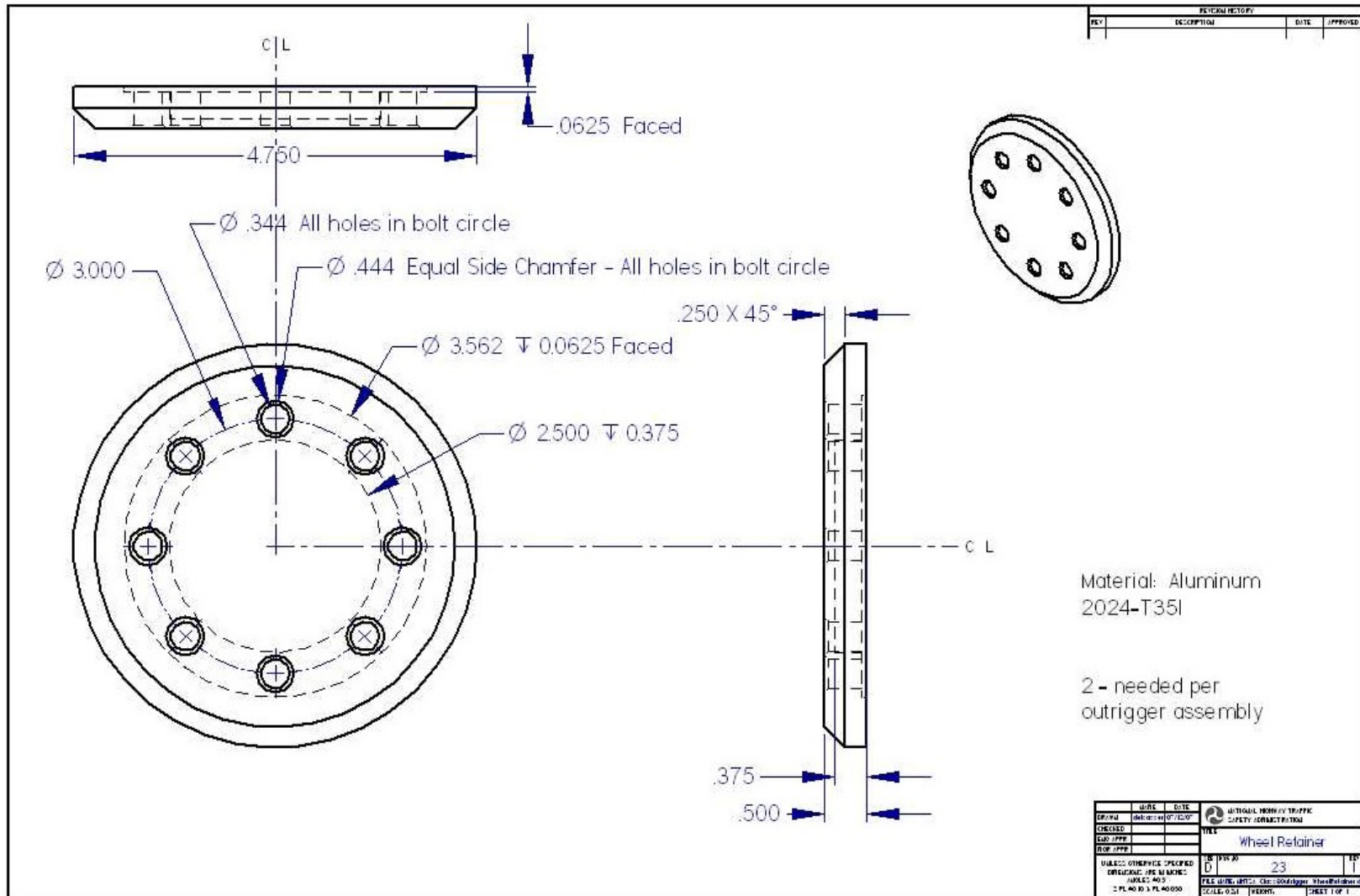

Figure A.30: Draft of Wheel Retainer.



## Pin Retainer Drawing

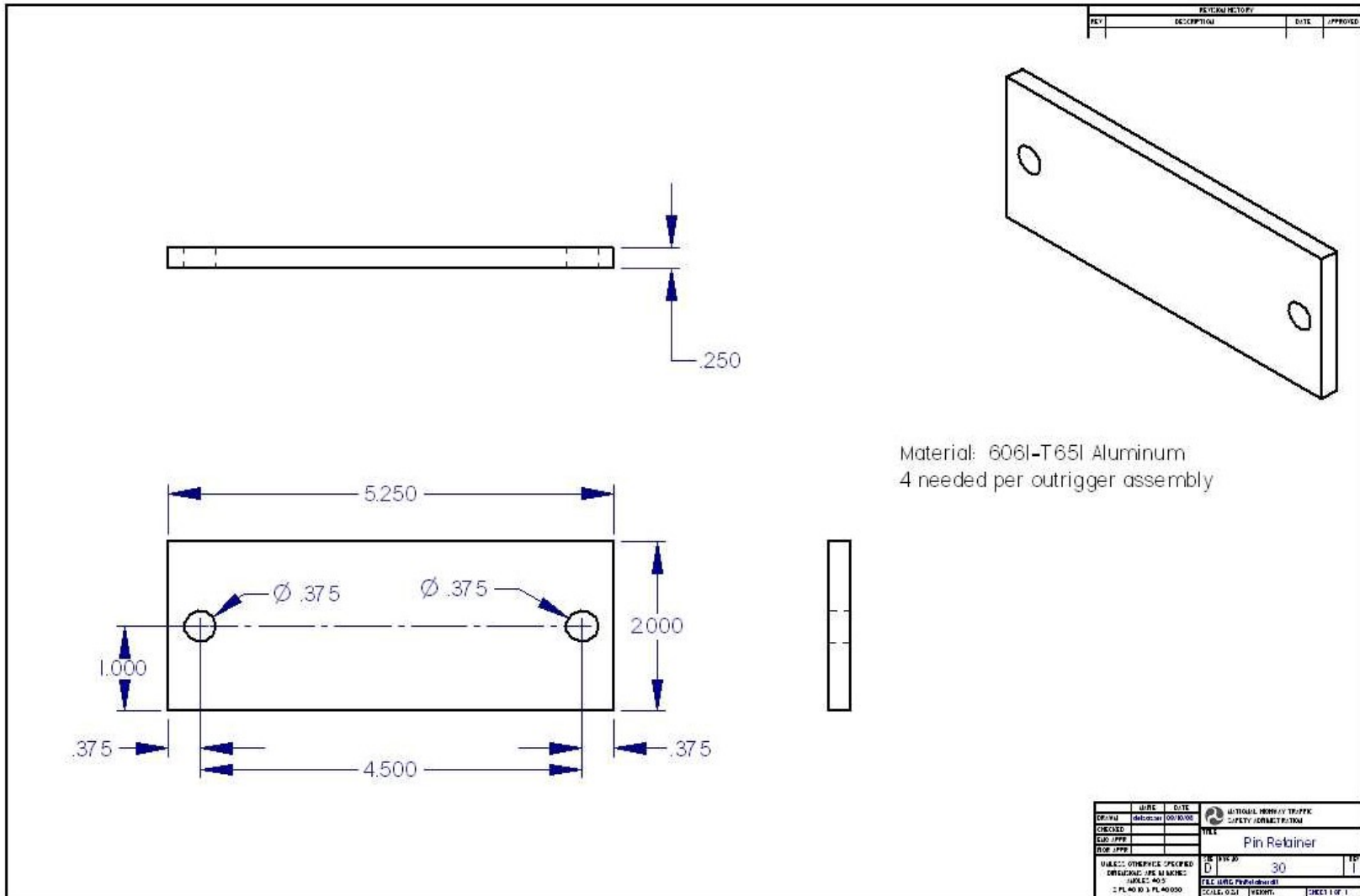

Figure A.32: Draft of Pin Retainer used to constrain Threaded Height Adjustment Round.

### Height Adjustment Round Pin Drawing

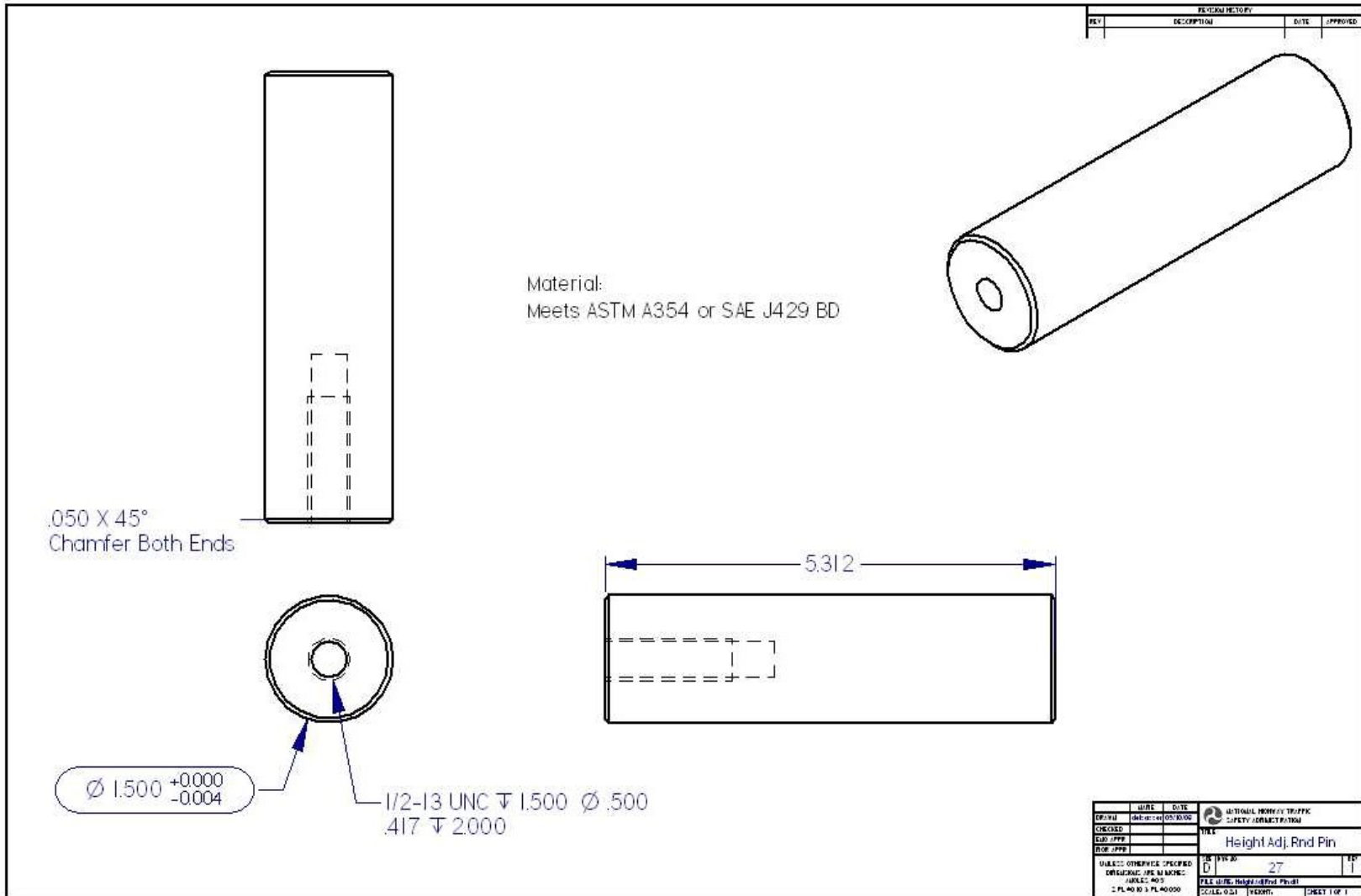

Figure A.33: Draft of Height Adjustment Round Pin used to constrain Height Adjustment Round with the threaded through hole.

## Free Body Diagram

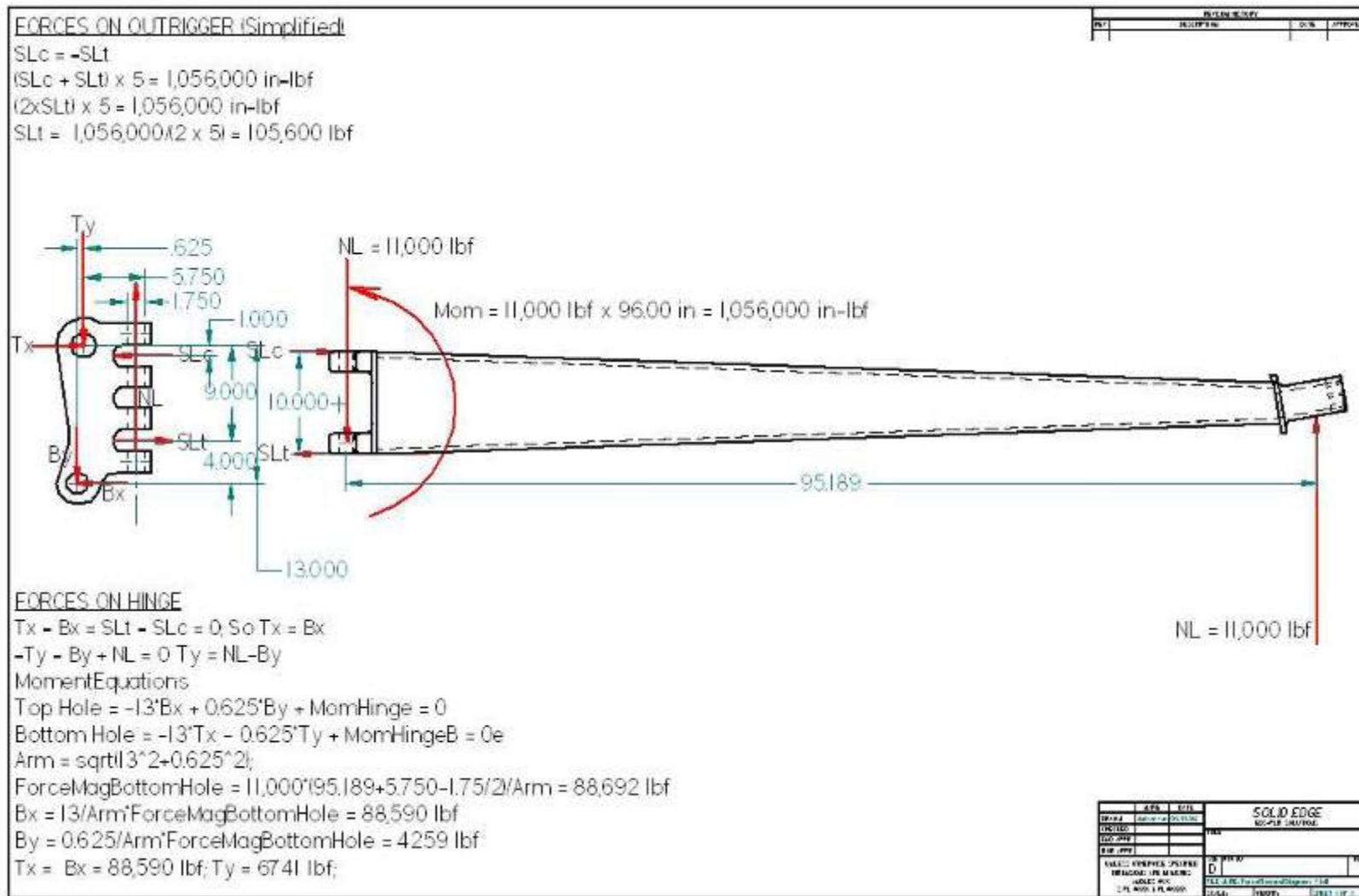

Figure A.34: Free-body-diagram showing simplified forces used for FEA analysis.



## Fastener List

### Bolts:

1. 1-1/2 – 12 UNF x 16 inches SAE Grade 8 Hex Bolts with threaded length of 13.25 inches.
  - a. Need 2 per outrigger assembly. These are the Adjustment Screws
2. 1-1/2 – 6 UNC x 16 inch SAE Grade 8 Hex Bolts with a threaded length of 2.5 inches.
  - a. Need 4 per outrigger assembly. Two of these go through the Upper Tabs and Hinges and the other two get turned down to a nominal diameter between 1.450 – 1.490 to become the pulling pins that allow the outriggers to fold.
3. 1-1/2 x 14.25 SAE Grade 8 Hex Head Shoulder Bolt with 1-1/4 – 7 UNC Body Thread with a body tolerance of 1.488 – 1.500.
  - a. Need 2 per outrigger assembly. These bolts are then designate as the pivot bolts that the outriggers are folded on for transport.
4. 1-1/2 – 6 UNC x 5.5 inches SAE Grade 8 Hex Bolts with a threaded length of 1.5 inches.
  - a. Need 8 per outrigger assembly. These bolts are used to retain the Height Adjustment Rounds.
5. For mounting the outriggers 1.25 to 1.5 inch diameter SAE Grade 8 bolts were used to fasten the outrigger assembly to the test vehicle. Adjust the length per the application.
  - a. Need 8 per outrigger assembly.
6. 5/16 – 24 UNF x 1.0 inches SAE Grade 8 Bolts
  - a. Need 16 per outrigger assembly.
7. 5/16 – 16 UNC x 1.0 inches SAE Grade 8 Bolts
  - a. Need 8 per outrigger assembly.

### Nuts:

1. 1-1/2 – 12 UNF SAE Grade 8 Hex Nut
  - a. Need 2 per outrigger assembly.
2. 1-1/2 – 6 UNC SAE Grade 8 Hex Nut
  - a. Need 2 per outrigger assembly.
3. 1-1/2 – 6 UNC SAE Grade 8 Hex Lock Nut – Nylon
  - a. Need 2 per outrigger assembly. These go on the bolts that the Outboard Beams pivot up and down on – Do not over tighten this joint - bolt should float from side to side [1/32 inch of free play side to side]
4. 1-1/4 – 7 UNC SAE Grade 8 Hex Nut
  - a. Need 2 per outrigger assembly. These go on the shoulder bolts.
5. Nuts needed for mounting the outrigger - per mounting application

All Fasteners should be assembled with the appropriate washer and lock washer where applicable.

## Load Cell Information

# MINIATURE HIGH-CAPACITY "TOP HAT" LOAD CELL 0-250 lb TO 0-100,000 lb CAPACITIES

### LC307 Series

#### Compression

0-250 lb to 0-100,000 lb  
0-114 kg to 0-45,372 kg

1 Newton = 0.2248 lb  
1 daNewton = 10 Newtons  
1 lb = 454 g  
1 t = 1000 kg = 2204 lb



LC307-500, \$375, shown larger than actual size.

Starts at  
**\$375**



Small in size but not in performance, Series LC307 top hat load cells are designed for applications with minimum space and high-capacity loads up to 100,000 lb. Rugged all stainless steel construction and high-performance strain gages ensure superior linearity and stability. Temperature compensation is done by a miniature circuit board in the load cell's cable. These cells are designed to be mounted on a smooth, flat surface.

### SPECIFICATIONS

Excitation: 5 Vdc

Output: 1.5 mV/V nominal

Accuracy: 0.75% FS BFSL (includes linearity, hysteresis and repeatability)

Zero Balance: ±2% FSO

Operating Temp Range:

-54 to 121°C (-65 to 250°F)

Compensated Temp Range:

16 to 71°C (60 to 160°F)

Thermal Effects:

Span: ±0.018% rdg/°C

Zero: ±0.018% FSO/°C

Safe Overload: 150% of capacity

Ultimate Overload: 300% of capacity

Bridge Resistance: 350 Ω minimum

Full Scale Deflection: 0.001 to 0.003"

Electrical Connection:

1.5 m (5') 4-conductor cable with compensation board

Protection Class: IP54

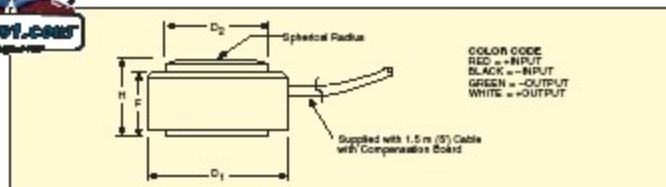

Dimensions: mm (in)

CAPACITY (lb)	D1	D2	H	F
250	13 (0.50)	6.9 (0.27)	9.7 (0.38)	9.1 (0.36)
500	13 (0.50)	7.1 (0.28)	9.7 (0.38)	9.1 (0.36)
1000	13 (0.50)	7.9 (0.31)	9.7 (0.38)	9.1 (0.36)
2000	13 (0.50)	10 (0.41)	9.7 (0.38)	9.1 (0.36)
3000	13 (0.50)	11 (0.45)	9.7 (0.38)	8.3 (0.33)
5000	16 (0.63)	13 (0.53)	15 (0.60)	13 (0.51)
7500	22 (0.88)	17 (0.67)	16 (0.63)	14 (0.54)
10,000	22 (0.88)	19 (0.76)	16 (0.63)	14 (0.54)
50,000	44 (1.75)	32 (1.25)	35 (1.38)	33 (1.29)
100,000	51 (2.00)	38 (1.50)	41 (1.63)	39 (1.54)

**MOST POPULAR MODELS HIGHLIGHTED!**

### To Order (Specify Model Number)

CAPACITY		MODEL NO.	PRICE	COMPATIBLE METERS**
lb	kg			
250	114	LC307-250	\$375	DPIS, DP41-S, DP25B-S
500	227	LC307-500	375	DPIS, DP41-S, DP25B-S
1000	455	LC307-1K	375	DPIS, DP41-S, DP25B-S
2000	909	LC307-2K	375	DPIS, DP41-S, DP25B-S
3000	1361	LC307-3K	375	DPIS, DP41-S, DP25B-S
5000	2269	LC307-5K	460	DPIS, DP41-S, DP25B-S
7500	3403	LC307-7.5K	460	DPIS, DP41-S, DP25B-S
10,000	4537	LC307-10K	460	DPIS, DP41-S, DP25B-S
50,000	22,696	LC307-50K	575	DPIS, DP41-S, DP25B-S*
100,000	45,372	LC307-100K	575	DPIS, DP41-S, DP25B-S*

Comes with 5-point NIST-traceable calibration.

\* 4-digit meter. \*\* See section D for compatible meters.

Ordering Examples: LC307-5K, 5000 lb capacity top hat load cell, \$460.

LC307-500, 500 lb capacity top hat load cell, \$375.

### ACCESSORY

MODEL NO.	PRICE	DESCRIPTION
OP-17	\$15	Reference Book: Measure for Measure

F-29

## Material Information

PRODUCT OFFERING

# Heflin ASTM A514

## Structural Alloy Steel Plate

### 3/16" through 6"

A514 is a low carbon alloy steel that has been heat treated by conventional liquid quenching and tempering to a strength level substantially higher than that of the high strength low alloy grades.

### Applications

A514 is used in general structural applications where its greater strength permits reduction in weight by using smaller cross-sectional areas. It is intended for welded construction where welding procedures are suitable to maintain the properties of the plate. Such applications include bridge and building members, body and frame members for earth-moving and transportation equipment, and components for heavy machinery.

### Design and Fabrication Advantages

**Weldable:** Techniques similar to those used in structural carbon steels apply, but precautions must be exercised. Hydrogen must be kept out of the welding operation. Large sections or those under high restraint should be preheated to temperatures not exceeding 400°F.

**Formable:** Structural quality material is readily cold formed, providing sufficient power is available and allowance is made for greater spring back than with mild steel.

Thickness of Material	Minimum Radius
Up to 1" inclusive	2 x thickness
Over 1" to 2" inclusive	3 x thickness

Warm forming may be done at temperatures below 1100°F without destroying the mechanical properties or toughness. Hot forming may be done at 1600-1800°F, but the formed part must be heat treated to restore its original properties.

**Machinable:** Cutting speed of structural quality is approximately 40% of that of 1212, or 65 surface feet per minute.

### Specifications

Structural: ASTM A514 Grades A, B, E, F, H, P, Q  
(Grades correspond to trade names of various steel producers)

### Mechanical Properties (Typical)

Yield Point Minimum: 100 ksi  
Tensile Strength: 120 ksi

Chemical Compositions	Gr. A*	Gr. B**	Gr. E*	Gr. F**	Gr. H**	Gr. P*	Gr. Q**
Spec. Thickness (max)	1-1/4"	1-1/4"	6"	2-1/2"	2"	6"	6"
Carbon (max)	.15/.21	.12/.21	.12/.20	.10/.20	.12/.21	.12/.21	.14/.21
Manganese	.80/1.10	.70/1.00	.40/.70	.60/1.00	.95/1.30	.45/.70	.95/1.30
Phosphorus (max)	.035	.035	.035	.035	.035	.035	.035
Sulfur (max)	.035	.035	.035	.035	.035	.035	.035
Silicon	.40/.80	.20/.35	.20/.40	.15/.35	.20/.35	.20/.35	.15/.35
Chromium	.50/.80	.40/.65	1.40/2.00	.40/.65	.40/.65	.85/1.20	1.00/1.50
Nickel	-	-	-	.70/1.0	.30/.70	1.20/1.50	1.20/1.50
Molybdenum	.18/.28	.15/.25	.40/.60	.40/.60	.20/.30	.45/.60	.40/.60
Copper	-	-	-	.15/.50	-	-	-

\* Post-weld heat treatment may degrade HAZ strength and toughness. Pretesting of specific welding and post-weld heat treating procedures is recommended to assure optimization of final property levels.

\*\* It is important to note that this grade of steel may be susceptible to cracking in the HAZ of welds during post-weld heat treatment (stress relief). Therefore, it is recommended that careful consideration be given to this phenomenon by competent welding engineers before stress relieving is applied to weldments of this grade. Also, it is not recommended for service at temperatures lower than -50°F or higher than 800°F.



1-800-528-4021  
www.heflinsteel.com

Heflin Steel  
PO Box 1249, Phoenix, AZ 85001  
1111 West Maricopa Freeway, Phoenix, AZ 85007  
602-252-8061 Fax: 602-256-9538  
E-mail: sales@heflinsteel.com

Hef-Plate-0902-2

© 2002 ESCO Corporation. Printed in the U.S.A. ESCO and Heflin are registered trademarks of ESCO Corporation.

## Welding A514 Steel Information (Internet)

## Welding ASTM A514 or A514M-05 steel?

Before you do, take a close look at filler metals, heat input

By Dean C. Phillips

June 12, 2007

As manufacturers strive for lower costs and greater efficiencies, they tend to substitute high-strength materials for standard materials. One such high-strength material is ASTM A514/514M-05. Although it is not difficult to weld, joining it successfully requires paying close attention to the preheat temperature, interpass temperature, and filler metal.



Cost and efficiency dictate manufacturing and fabricating trends in most industries. In addition to implementing lean work flow practices—better, faster transportation and processing and minimal inventory—many companies turn to the use of higher-strength, lighter-weight materials to reduce costs and improve welding productivity.

ASTM A514 and A514M-05 high-strength, low-alloy, quenched-and-tempered steels are among these materials. Although they have been available for many years, they continue to pose some distinct challenges for welders. Welding these materials successfully is a matter of understanding some key factors, including filler metal choices and preheating and interpass heat requirements. **What It Is, Why It Is**

ASTM A514 is a specification for 100 kilopounds-per-square-inch-yield, low-alloy, quenched-and-tempered steel intended for structural applications and is typically known in the industry as USS (United States Steel) nomenclature T1®, regardless of the manufacturer.

A514 grades are A, B, E, F, H, P, Q, and S. Each grade has a unique chemistry and may differ in the maximum thickness to which it is rolled, from 1-1/4 in. to 6 in. The material thickness affects the mechanical properties. For instance, A514 rolled to 2 1/2 in. or less must have 110-KSI to 130-KSI tensile strength, 100-KSI minimum yield strength, and 18 percent elongation. For materials 2 1/2 to 6 in. thick, the mechanical properties are 100-KSI to 130KSI tensile strength, 90-KSI minimum yield strength, and 16 percent elongation.

The hardness for material thickness up to and including 3/4 in. is 235 to 293 HBW (Brinell). Note that the specification does not list hardness requirements for materials thicker than 3/4 in.

One of the reasons for the difference in properties among these thicknesses is the quenching. The thicker the material, the slower the quench rate, which results in lower minimum yield and tensile strengths.

Typically, this material is used for structural applications. In many cases, the term structural refers to buildings, but the material also is used in heavy equipment structures to reduce weight and improve payload capacity, such as in railcars and their components, large mining truck frames, semitrailer frames, and crane boom sections.

Because the typical hardness of the materials is 22 to 27 Rockwell C, it is also used for wear strips, cutting edges, and side cutters. Typical applications are backhoe buckets and other wear components in earthmoving equipment.

**Making the Choice: Filler Metals**

Welding A514 is not complicated when some precautions, especially with filler metal choices, are used.

A primary concern is filler metal hydrogen content. You should not use filler metals that deposit weld metal with diffusible hydrogen content greater than 8 ml per 100 grams of deposited weld metal. A514 is sensitive to diffusible hydrogen, which may result in hydrogen cracking.

Filler Metal Selection ASTM A514 and A514M-05 up to 2 1/2 Inches Thick		
Welding Process	AWS A5 Specification	Classification
SMAW	A5.5/A5.5M-2005	E11018M or E12018M
GMAW	A5.28/A5.28M-2005	Solid electrodes ER 110S-1 and ER120S-1 or Metal-cored electrodes E110C-K3, E110C-K4, and E120C-K4
FCAW	A5.29/A5.29M-2005	E11XT1-K3C and -K3M E11XT5-K3C and -K3M E11XT5-K4C and -K4M E12XT5-K4C and -K4M
SAW	A5.23/A5.23M-1997	Solid electrode/flux combination F11AX-EXXX-XXX and F12AX-EXXXXXX or Composite electrode/flux combination F11AX-ECXXX-XXX and F12AX-ECXXX-XXX

Figure 1

The filler metal strength depends on the application of the A514. **Figure 1** shows filler metals you can use to match the strength of base materials up to 2 1/2 in. thick where the same mechanical properties as the base material are required. On base material thicknesses greater than 2 1/2 in., you can use the same filler metals, but their strength exceeds that of the base metal, a condition called overmatching strength (see **Figure 2**).

Filler Metal Selection ASTM A514 and A514M-05 Greater Than 2 1/2 Inches Thick		
Welding Process	AWS A5 Specification	Classification
SMAW	A5.5/A5.5M-2005	E10018M
GMAW	A5.28/A5.28M-2005	Solid electrodes ER 100S-1 or Metal-cored electrodes E100C-K3
FCAW	A5.29/A5.29M-2005	FCAW A5.29/A5.29M-2005 E10XT1-K3C and -K3M E10XT5-K3C and -K3M E10XT1-K7C and -K7M E10XT1-K9C and -K9M
SAW	A5.23/A5.23M-1997	Solid electrode/flux combination F10AX-EXXX-XXX or Composite electrode/flux combination F10AX-ECXXX-XXX

**Figure 2**

When joining A514 to other low-alloy steels or carbon steels of lower strength, use a filler metal with strength that meets the lower-strength base material's properties. For example, when welding ASTM A36 to A514, use a 70-KSI tensile-strength electrode to match the lower-strength material. Don't focus solely on strength; keep the hydrogen cracking risk in mind.

### Heat Input Control

Even though A514 is readily weldable, excessive preheat and interpass temperatures and welding heat input can affect the alloy's chemical properties. **Figure 3** lists typical preheat and interpass temperatures for A514. These temperatures apply whether you are welding A514 to itself or to other, lower-strength materials.

Thickness (In.)	Maximum Preheat and Interpass Temperature (F)	Maximum Preheat and Interpass Temperature (F)
Up to 3/4	50	400
3/4 – 1 1/2	125	
1 1/2 – 2 1/2	175	400
More than 2 1/2	225	

**Figure 3**

Although welding A514 is not difficult, joining it successfully requires close attention to the preheat and interpass temperatures.

It should be noted that preheat and interpass temperatures higher than those shown in Figure 3 may alter the mechanical properties of the material. Tempil® Sticks, contact pyrometers, infrared thermometers, or other heatmeasuring devices should be used to control preheat and interpass temperatures.

In addition to the preheat and interpass temperature controls, heat input, which is a function of amperage, voltage, and travel speed, must be restricted. Heat input is expressed in joules per inch. The formula is:

$$\text{Heat Input (joules/in.)} = (\text{Amperage} \times \text{Voltage} \div 60) \div \text{Travel Speed (IPM)}$$

Typical heat input is about 55,000 joules per in. ( $\pm 20$  percent). For other heat inputs, it is advisable to contact the steel manufacturer for recommendations.

As a final precaution, A514 is not intended to be used in the postweld heat-treated (PWHT) condition, as it will alter the mechanical properties for which the material was intended.

Other sources of information for welding A514/A514M-05 steel are the steel manufacturers' fabrication guides and:

- AWS D1.1, Structural Code—Steel
- D14.3, Specification for Welding
- Earthmoving, Construction, and
- Agricultural Equipment
- D15.1, Railroad Welding Specification— Cars and Locomotives.

### Want more information?

- "Cracking the case" 1397
- "MIG—welding tips and resources" 1083
- "Preventing welding-related fires" 952

## Dean C. Phillips

Manager of Welding Engineering, Hobart Brothers Co.

Dean C. Phillips is manager of welding engineering for Hobart Brothers Co., 101 Trade Square, Troy, OH 45373, 937-332-4000, [www.hobartbrothers.com](http://www.hobartbrothers.com).

## **List of Suppliers Used To Fabricate Outriggers**

### **Steel – raw/laser/water cut parts Spradlin**

Bros. Welding Co.  
2131 Quality Lane  
Springfield, OH 45505  
Phone: 937-323-2992  
Web: <http://spradlinbros.com/>

Benjamin Steel Co., Inc  
1825 Kuntz Road  
Dayton OH 45404-1257  
Phone: 937-233-1212  
Web: <http://www.benjaminsteel.com/index.htm>

### **Aluminum**

EMJ – Earle M. Jorgensen  
601 Redna Terrace  
PO Box 15100  
Cincinnati, OH 45215  
Phone: 513-771-3223  
Web: <http://www.emjmetals.com/>

Clinton Aluminum and Stainless Steel  
6270 Van Buren Road Clinton,  
OH 44216  
Phone: 330-882-6749  
Web: <http://www.clintonaluminum.com/>

**Plastic**

GE Polymershapes  
2554 Needmore Road  
Dayton, OH 45414  
Phone: 800-762-2342  
Web: <http://www.gepolymershapes.com/polyshapes/en/Home/Home/home.html>

**Bushings**

DAEMAR INC.  
1730 Cumberland Point Drive  
Marietta, GA 30067-9205  
Phone: 877-432-3227  
Web: [http://www.daemar.com/bushing\\_bearings\\_19.html](http://www.daemar.com/bushing_bearings_19.html)

**Fasteners**

Chicago Nut and Bolt  
150 Covington Drive  
Bloomington, IL 60108  
Phone: 888-529-8620  
Web: [www.chicagonutandbolt.com](http://www.chicagonutandbolt.com)

American Fasteners Technologies Corp.  
Nine Frontier Drive  
Gibsonia, PA 15044-7992  
Phone: 800-466-9780  
Web: <http://www.americanfastener.com/index.htm>

MSC Industrial Supply Co., INC  
75 Maxess Road  
Melville, NY 11747-3151  
Phone: 800-645-7270  
Web: <http://www1.mscdirect.com/cgi/nnsrhm>

McMaster-Carr PO  
Box 94930  
Cleveland, OH 44101-4930  
Phone: 330-995-5500  
Web: <http://www.trcpg.com/index.asp>

**Machine Shops**

Schaefer's Machining, INC.  
580 North Main Street  
PO Box 408  
Lakeview, OH 43331



**Fabrication TRC Inc.**

P.O. Box B-67  
10820 State Route 347  
East Liberty, Ohio 43319-0367  
Phone: (937) 666-2011  
Web: <http://www.trcpg.com/index.asp>

Spradlin Bros. Welding Co.  
2131 Quality Lane  
Springfield, OH 45505  
Phone: 937-323-2992  
Web: <http://spradlinbros.com/>



DOT HS 811 289  
April 2010



U.S. Department  
of Transportation  
**National Highway  
Traffic Safety  
Administration**

