



Powering Business Worldwide

User's and installation guide

Eaton 93PM UPS 30–250 kVA

P-164000249

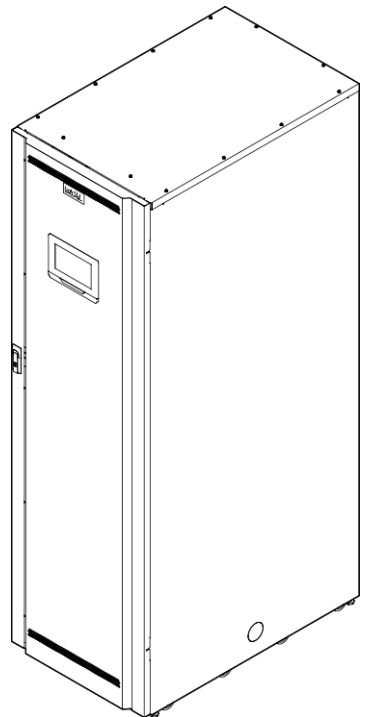

Copyright © 2018 Eaton Corporation plc. All rights reserved.

This manual contains important instructions that you should follow during installation and maintenance of the UPS and batteries. Please read all instructions before operating the equipment and save this manual for future reference.

This is a product for commercial and industrial application in the second environment. Installation restrictions or additional measures may be needed to prevent disturbances. The contents of this manual are the copyright of the publisher and may not be reproduced (even extracts) without the written approval of Eaton Corporation. Every care has been taken to ensure the accuracy of the information contained in this manual, but no liability can be accepted for any errors or omission. The right to make design modifications is reserved.

Unauthorized copying and lending are prohibited.

Eaton Power Quality Oy

Address: Koskelontie 13
FI-02920 Espoo
FINLAND

Internet: www.eaton.eu

Original instructions _X_ / Translation of the original instructions __

Contents

| | | |
|----------|---|-----------|
| 1 | How to read this manual..... | 7 |
| 1.1 | Safety-related signs..... | 7 |
| 1.2 | Safety symbols..... | 7 |
| 1.2.1 | Hazard symbols..... | 7 |
| 1.2.2 | Prohibited action symbols..... | 7 |
| 1.2.3 | Mandatory action symbols..... | 8 |
| 1.3 | Conventions used in this document..... | 8 |
| 1.4 | Glossary..... | 8 |
| | | |
| 2 | Safety instructions..... | 10 |
| 2.1 | Audience..... | 12 |
| 2.2 | CE marking..... | 12 |
| 2.3 | User precautions..... | 12 |
| 2.4 | Environment..... | 13 |
| 2.5 | Symbols on the UPS and accessories..... | 13 |
| 2.6 | For more information..... | 14 |
| | | |
| 3 | Introduction to Eaton UPS..... | 15 |
| 3.1 | Looking inside the UPS system..... | 16 |
| 3.2 | UPS operating modes..... | 18 |
| 3.2.1 | Normal operating modes..... | 19 |
| 3.2.2 | Stored energy and battery mode..... | 23 |
| 3.2.3 | Bypass mode..... | 25 |
| 3.3 | UPS features..... | 27 |
| 3.3.1 | Advanced Battery Management..... | 27 |
| 3.3.2 | Powerware Hot Sync..... | 27 |
| 3.3.3 | Power Conditioner..... | 28 |
| 3.3.4 | Frequency Converter..... | 28 |
| 3.3.5 | Sync Control..... | 28 |
| 3.4 | Software and connectivity features..... | 29 |
| 3.4.1 | User interface..... | 29 |
| 3.4.2 | Power Management Software..... | 29 |
| 3.5 | Options and accessories..... | 29 |
| 3.5.1 | Maintenance Bypass Switch..... | 29 |
| 3.5.2 | 93PM 200 kW SIAC-MBS..... | 30 |
| 3.5.3 | Top air exhaust kit..... | 30 |
| 3.5.4 | Top cable access kit..... | 30 |
| 3.5.5 | Single feed kit..... | 30 |
| 3.5.6 | Separate battery option..... | 30 |
| 3.5.7 | Field Installed UPM..... | 30 |
| 3.6 | Battery system..... | 31 |

| | | | |
|----------|-------|--|-----------|
| | 3.6.1 | UPS Battery Switchgear..... | 31 |
| 3.7 | | Basic system configurations..... | 32 |
| 4 | | UPS installation plan and unpacking..... | 35 |
| | 4.1 | Creating an installation plan..... | 35 |
| | 4.2 | Installation checklist..... | 36 |
| | 4.3 | Site preparations..... | 36 |
| | | 4.3.1 Environmental and installation considerations..... | 37 |
| | | 4.3.2 UPS system power wiring preparations..... | 41 |
| | 4.4 | Unpacking and unloading the UPS..... | 47 |
| 5 | | UPS system installation..... | 51 |
| | 5.1 | Installing the UPS..... | 51 |
| | 5.2 | Connector and power cable terminal locations..... | 56 |
| | 5.3 | Installing 93PM 160-200kW with side integrated accessory cabinet MBS..... | 59 |
| | 5.4 | Installing the battery system..... | 63 |
| | | 5.4.1 Installing the battery system for 93PM UPS with separate battery option..... | 65 |
| | | 5.4.2 Battery trip wiring..... | 66 |
| | 5.5 | Installing a remote EPO switch | 70 |
| | 5.6 | Installing interface connections..... | 71 |
| | | 5.6.1 Installing customer input signals interface..... | 72 |
| | | 5.6.2 Battery breaker wiring interface..... | 72 |
| | | 5.6.3 Relay output interface connections..... | 72 |
| | | 5.6.4 Industrial Relay Card interface connections..... | 72 |
| | | 5.6.5 MiniSlot interface connections..... | 73 |
| | | 5.6.6 Installing signal interface connections in a parallel system..... | 74 |
| | 5.7 | Wiring parallel 93PM UPS systems..... | 74 |
| | | 5.7.1 Power wiring overview..... | 74 |
| | | 5.7.2 Control signals overview..... | 76 |
| | | 5.7.3 Installing bypass control wiring..... | 77 |
| | 5.8 | UPS system interface wiring preparation..... | 80 |
| 6 | | Communication interfaces..... | 81 |
| | 6.1 | MiniSlot cards..... | 81 |
| | 6.2 | Intelligent Power Software..... | 83 |
| | 6.3 | Signal input monitoring..... | 84 |
| | 6.4 | General purpose relay contact..... | 84 |
| | 6.5 | Configuring relays..... | 85 |



| | | |
|----------|---|------------|
| 7 | UPS operating instructions..... | 89 |
| 7.1 | UPS controls and indicators..... | 89 |
| 7.1.1 | Control panel..... | 89 |
| 7.1.2 | Status indicators..... | 90 |
| 7.1.3 | System events..... | 92 |
| 7.1.4 | Menu structure of the 93PM UPS..... | 92 |
| 7.2 | Signing in..... | 96 |
| 7.3 | System control instructions..... | 97 |
| 7.3.1 | Starting the UPS system in the double conversion mode..... | 97 |
| 7.3.2 | Starting the UPS system in the bypass mode..... | 98 |
| 7.3.3 | Transferring from the double conversion mode to the bypass mode..... | 98 |
| 7.3.4 | Transferring from the bypass mode to the double conversion mode..... | 99 |
| 7.3.5 | Transferring from the double conversion mode to the Energy Saver System mode..... | 99 |
| 7.3.6 | Transferring from the Energy Saver System mode to the double conversion mode..... | 99 |
| 7.3.7 | Shutting down the UPS system and critical load..... | 100 |
| 7.3.8 | De-energizing the critical load..... | 100 |
| 7.4 | UPS control instructions..... | 101 |
| 7.4.1 | Starting a single UPS..... | 101 |
| 7.4.2 | Shutting down a single UPS..... | 102 |
| 7.4.3 | Enabling and disabling the battery charger..... | 102 |
| 7.5 | UPM control instructions..... | 102 |
| 7.5.1 | Starting the UPMs..... | 102 |
| 7.5.2 | Shutting down the UPMs..... | 103 |
| 7.6 | Using the Remote Emergency Power-off switch..... | 103 |
| 7.7 | Turning the UPS from the double conversion mode to the maintenance bypass mode..... | 104 |
| 7.8 | Turning the UPS from the maintenance bypass mode to the double conversion mode..... | 106 |
| 8 | UPS maintenance..... | 108 |
| 8.1 | Important safety instructions..... | 108 |
| 8.2 | Preventive maintenance..... | 109 |
| 8.2.1 | Daily maintenance..... | 109 |
| 8.2.2 | Monthly maintenance..... | 109 |
| 8.2.3 | Periodic maintenance..... | 110 |
| 8.2.4 | Annual maintenance..... | 110 |
| 8.2.5 | Battery maintenance..... | 110 |
| 8.3 | Recycling the used UPS or batteries..... | 110 |
| 8.4 | Maintenance training..... | 111 |

| | | |
|--------------------|--|------------|
| 9 | Technical data..... | 112 |
| 9.1 | Directives and standards..... | 112 |
| 9.2 | UPS system input..... | 113 |
| 9.3 | UPS system output..... | 113 |
| 9.4 | UPS environmental specifications..... | 114 |
| 9.5 | Battery specification..... | 115 |
| | | |
| 10 | Warranty..... | 116 |
| 10.1 | General..... | 116 |
| 10.2 | Whom to contact in case of Warranty..... | 117 |
| | | |
| Appendix A: | Relay Alarms..... | 118 |

1 How to read this manual

1.1 Safety-related signs

The following table explains the safety-related signs used in this document.

| | |
|--|--|
|  DANGER | DANGER indicates a hazard with a high level of risk which, if not avoided, will result in serious injury or death. |
|  WARNING | WARNING indicates a hazard with a medium level of risk which, if not avoided, could result in serious injury or death, or damage to your machine. |
|  CAUTION | CAUTION indicates a hazard with a low level of risk which, if not avoided, could result in minor or moderate injury, or damage to your machine. |







Note: Notes are used to indicate important information and useful tips.

1.2 Safety symbols



1.2.1 Hazard symbols

These symbols indicate a hazardous situation or action. Symbols are used to warn of situations, which may cause environmental damage and personal injury.

| | | | |
|---|----------------------|---|---------------------------|
|  | General warning sign |  | Explosion and fire hazard |
|  | Electrical hazard |  | Corrosive hazard |
|  | Battery hazard | | |



1.2.2 Prohibited action symbols

These symbols are used to indicate an action that should not be taken.

| | | | |
|---|--------------------------------------|---|------------|
|  | General symbol for prohibited action |  | No smoking |
|  | Limited or restricted access | | |

1.2.3 Mandatory action symbols

These symbols are used to indicate an action that must be taken.

| | | | |
|---|-------------------------------------|---|------------------------------|
|  | General symbol for mandatory action |  | Disconnect from power source |
|  | Read the manual or instructions | | |

1.3 Conventions used in this document

This document uses the following type conventions:

- **Bold type** highlights important concepts in discussions, key terms in procedures and menu options, or represents a command or option that you type or enter at a prompt.
- *Italic type* highlights notes and new terms when they are defined.
- **Screen type** represents information that appears on the screen or LCD.

1.4 Glossary

Eaton documentation uses the following acronyms to refer to Eaton UPS products or their parts:

Table 1: Glossary of acronyms

| | |
|------------|------------------------------|
| ABM | Advanced Battery Management |
| BIB | Bypass Input Breaker |
| EAA | Energy Advanced Architecture |
| EBC | External Battery Cabinet |

| | |
|--------------|-----------------------------------|
| EPO | Emergency Power-off |
| ESS | Energy Saver System |
| F-UPM | Field Installed UPM |
| IPM | Intelligent Power Manager |
| IPP | Intelligent Power Protector |
| MBP | Maintenance Bypass |
| MBS | Maintenance Bypass Switch |
| MCB | Miniature Circuit Breaker |
| MIS | Maintenance Isolation Switch |
| MOB | Module Output Breaker |
| REPO | Remote Emergency Power-off |
| RIB | Rectifier Input Breaker |
| SCR | Silicon-controlled Rectifier |
| STSW | Static Switch |
| UPM | Uninterruptible Power Module |
| UPS | Uninterruptible Power Supply |
| VMMS | Variable Module Management System |

2 Safety instructions



DANGER

Important safety instructions!
Keep these instructions!

This document contains important instructions that must be obeyed during the installation, operation and maintenance of the UPS and the batteries. Read all instructions before operating the equipment. Keep this manual for future reference. These instructions are also available for download at www.eaton.eu/93pm.



DANGER

Operations inside the UPS must be done by an authorized Eaton Customer Service Engineer or by other qualified service personnel authorized by Eaton. There are no user-serviceable parts in the UPS.

The UPS operates with mains, battery or bypass power. It contains components that carry high currents and voltage. A properly installed enclosure is earthed and IP20 rated against electric shock and unwanted objects. The UPS is a sophisticated power system and only qualified personnel can install and service it.



DANGER

This UPS carries lethal voltages. All repairs and service must be done by authorized personnel only. There are no user-serviceable parts inside the UPS.



WARNING

The UPS is powered by its own energy source (batteries). The output terminals could be energized even when the UPS is disconnected from an AC source. To reduce the risk of fire or electric shock, install the UPS in a temperature and humidity controlled, indoor environment that is free of conductive contaminants. See temperature and humidity limits in Chapter 9.

The ambient temperature limit must not be exceeded. Do not operate the UPS near water or excessive humidity. The system is not intended for outdoor use.

Before you start any installation or service work, make sure that all AC and DC power sources are disconnected. Power can come from multiple sources. Also ensure system grounding / PE continuity.

In a parallel system, the output terminals could be energized even when the UPS is turned off.

WARNING

Batteries present a risk of electric shock or burn from high short-circuit current. Observe proper precautions.

Electric energy hazard. Do not attempt to alter any battery wiring or connectors. Attempting to alter wiring can cause injury.

Do not open or mutilate batteries. Released electrolyte can be toxic and is harmful to the skin and eyes.

Batteries can contain HIGH VOLTAGES, and CORROSIVE, TOXIC and EXPLOSIVE substances. Because of the battery string the output terminals can carry high voltage even when the AC supply is not connected to the UPS. Read the shutdown instructions carefully.

IMPORTANT: The battery may consist of multiple parallel strings. Make sure that you disconnect all strings before installation.

CAUTION

Only qualified service personnel knowledgeable of batteries and the required precautions can do the installation or service work on batteries. Keep unauthorized personnel away from the batteries. Before you install or replace batteries, consider all the warnings, cautions, and notes concerning appropriate handling. Do not disconnect the batteries when the UPS is in the Battery mode.

Make sure that your replacement batteries are of the same number and type as the battery that was originally installed in the UPS. See more accurate instructions on the UPS.

Before you connect or disconnect battery terminals, disconnect the charging source by opening the corresponding battery circuit breaker.

If the battery is inadvertently grounded, remove the source of the ground. Contacting any part of a grounded battery can cause a risk of electric shock. If you disconnect the grounding connection before you work on the batteries, the risk of an electric shock is less likely.

Dispose of batteries according to your local disposal requirements. Do not dispose of batteries in a fire. When exposed to flame, batteries may explode.

To ensure proper cooling airflow and to protect personnel from dangerous voltages inside the unit, keep the UPS door closed and the front panels installed.

Do not install or operate the UPS system close to gas or electric heat sources. Keep the operating environment within the parameters stated in this document.

**CAUTION**

Keep the surroundings of the UPS uncluttered, clean, and free from excess moisture.

Obey all DANGER, CAUTION, and WARNING notices on the equipment.

2.1 Audience

This document is intended for:

- People who plan and perform the installation of the UPS
- People who use the UPS

This document provides guidelines for how to examine the UPS delivery and how install and operate the UPS.

The reader is expected to know the fundamentals of electricity, wiring, electrical components and electrical schematic symbols. This document is written for a global reader.

CAUTION

Read this document before you start to operate or perform work on the UPS.

2.2 CE marking

The product has a CE marking in compliance with the following European directives:

- LV Directive (Safety) 2014/35/EU
- EMC Directive 2014/30/EU

Declarations of conformity with UPS harmonized standards and directives EN 62040-1 (Safety) and EN 62040-2 (EMC) are available at www.eaton.eu or by contacting your nearest Eaton office or authorized partner.

2.3 User precautions

The only permitted user operations.

- Startup and shutdown of the UPS, excluding the commissioning startup.
- Use of the LCD control panel and the Maintenance Bypass Switch (MBS).
- Use of optional connectivity modules and their software.

Obey the precautions and only perform the described operations. Any deviation from the instructions can be dangerous to the user or cause accidental load loss.

DANGER

Do not open any other screws in the unit than those holding the cover plates of the MiniSlots and the MBS locking plate. Failure to recognize the electrical hazards can prove fatal.

CAUTION

The 30–50 kW models are available as a C2 category UPS as an option, which can be placed both in residential and commercial or industrial environments. When included in a residential environment, this product may cause radio interference. In which case you may have to take preventive measures.

By standard, this is a C3 category product for commercial and industrial application in the second environment. Installation restrictions or measures may be needed to prevent disturbances.

2.4 Environment

The UPS must be installed according to the recommendations in this document. Never install the UPS in an airtight room, in the presence of flammable gases, or in an environment exceeding the specifications.

Excessive amount of dust in the operating environment of the UPS may cause damage or lead to malfunction. Always protect the UPS from the outside weather and sunshine.

WARNING





During charge, float charge, heavy discharge, and overcharge, hydrogen and oxygen gases are emitted from lead-acid and NiCd batteries into the surrounding atmosphere. Explosive gas mixture may be created if the hydrogen concentration exceeds 4% by volume in air. Ensure the necessary air flow rate for the ventilation of the UPS location.

2.5 Symbols on the UPS and accessories

The following are examples of symbols used on the UPS or its accessories. The symbols are used to alert you of important information.

**RISK OF ELECTRIC SHOCK**

Indicates that a risk of electric shock is present and the associated warning should be observed.

| | |
|---|---|
|  | <p>CAUTION: REFER TO OPERATOR'S MANUAL</p> <p>Refer to your operator's manual for additional information, such as important operating and maintenance instructions.</p> |
|  <p>Pb</p> | <p>This symbol indicates that you may not discard the UPS or the UPS batteries in the trash. This product involves sealed, lead-acid batteries and they must be disposed of properly. For more information, contact your local recycling / reuse or hazardous waste center.</p> |
|   | <p>This symbol indicates that you may not discard waste electrical or electronic equipment (WEEE) in the trash. For proper disposal, contact your local recycling / reuse or hazardous waste center.</p> |

2.6 For more information

Address any inquiries about the UPS and the battery cabinet to the local office or an agent authorized by the manufacturer. Quote the type code and the serial number of the equipment.

Call your local service representative if you need help with any of the following:

- scheduling initial startup
- regional locations and telephone numbers
- a question about any of the information in this manual
- a question that this manual does not answer



Note: For more information about the installation space, safe operation and working, see IEC 62485-2: Safety requirements for secondary batteries and battery installations.

3 Introduction to Eaton UPS

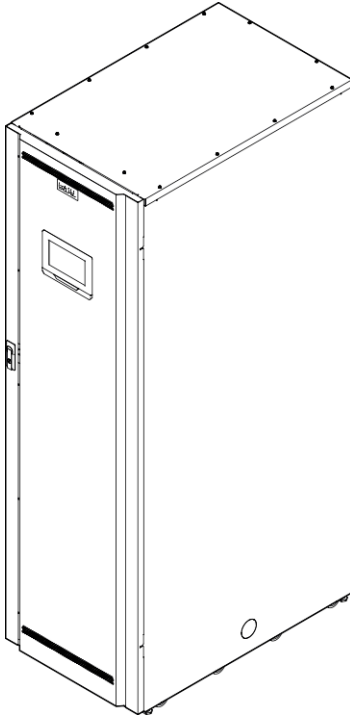

Figure 1. Eaton 93PM UPS

The Eaton® 93PM uninterruptible power supply (UPS) is a true online, continuous-duty, transformerless, double-conversion, solid-state, three-phase system that supplies conditioned and uninterruptible AC power to critical load and protects it from power failures.

The UPS is used to prevent loss of valuable electronic information, minimize equipment downtime, and minimize the adverse effect on production equipment due to unexpected power problems.

The Eaton UPS continually monitors incoming electrical power and removes the surges, spikes, sags, and other irregularities that are inherent in commercial utility power. Working with a building's electrical system, the UPS system supplies clean, consistent power that sensitive electronic equipment require for reliable operation. During brownouts, blackouts, and other power interruptions, batteries provide emergency power to safeguard operation.

The UPS system is housed in a single, free-standing cabinet with safety shields behind the door for protection against hazardous voltage. Each UPS cabinet has

a centralized system static bypass. The static bypass size is chosen according to UPS system power.

Eaton 93PM 30-250 kVA UPS is a modular product, consisting of one to four uninterruptible power modules (UPM). A UPM includes a rectifier, inverter, battery converter and independent controls. Each UPM is able to operate independently from the other power modules.

See Section [3.7](#) for a full list of available configurations.



Note: Startup and operational checks must be performed by an authorized Eaton Customer Service Engineer or by other qualified service personnel authorized by Eaton, or the terms specified in the Warranty (see Chapter [10](#)) become void. This service is offered as part of the sales contract for the UPS. Contact service in advance (usually a two-week notice is necessary) to reserve a preferred start-up date.

3.1 Looking inside the UPS system

The system level static bypass in the Eaton 93PM UPS cabinet determines the attainable output power of the UPS. The static bypass line consists of static switch, a back feed protection isolation device and fuses designed to protect the static switch. The back feed protection and bypass fuses are located in series with the static switch. In addition, there is a system level control unit that constantly monitors the power delivered through the bypass line or to the input of the UPS. Transfers to static bypass are seamless and performed automatically by the system as needed, for example, in case of an extended system overload.

Each UPM includes a rectifier, battery converter, inverter and independent controls. Each UPM is able to operate and share the load independently, despite the status of the other UPMs.

If utility power is interrupted or falls outside the parameters specified in Chapter [9](#), the UPS uses a backup battery supply to maintain power to the critical load for a specified period of time or until the utility power returns. For extended power outages, the UPS allows you to either transfer to an alternative power system (such as a generator) or shut down your critical load in an orderly manner.

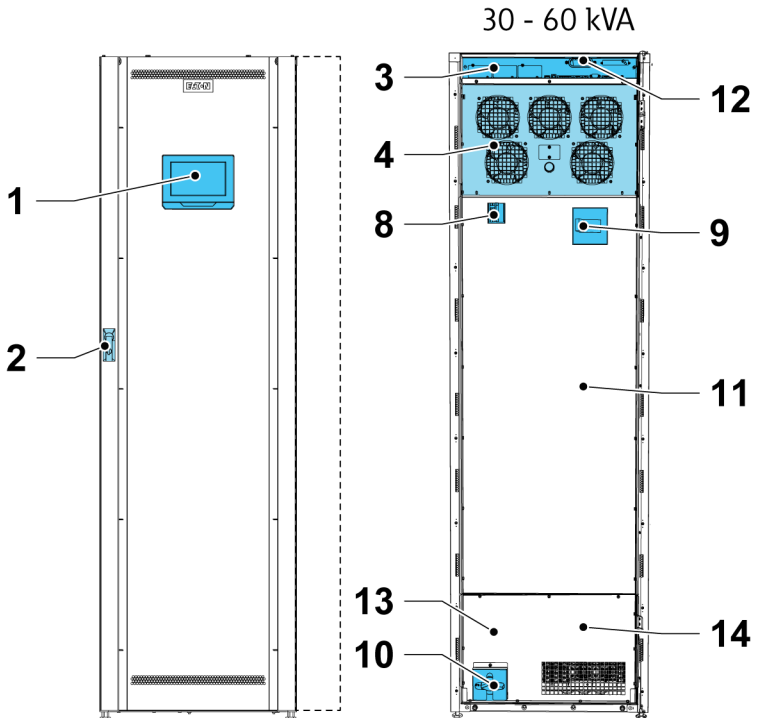

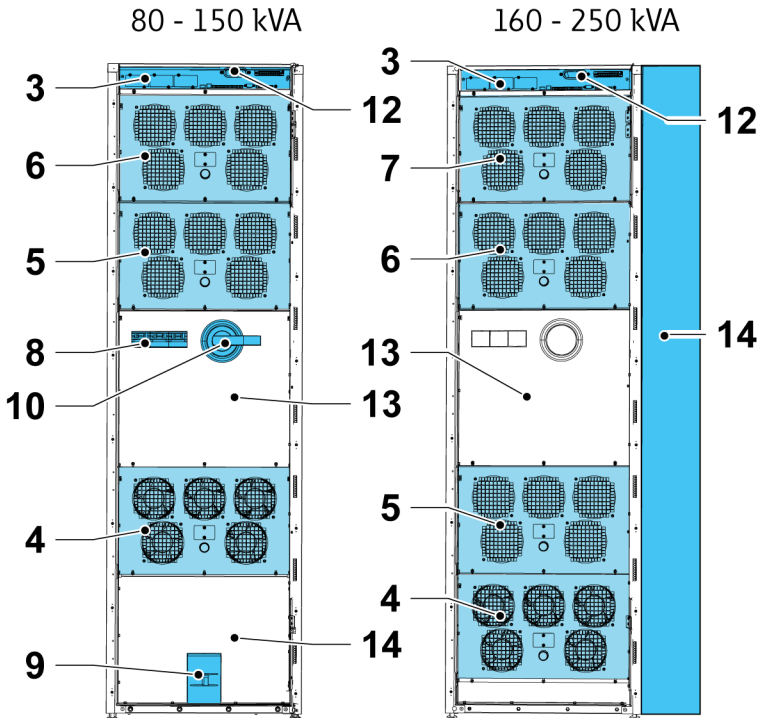

- | | |
|--|--|
| <ul style="list-style-type: none"> 1 Control panel 2 Door latch 3 Communications area 4 UPM 1 5 UPM 2 6 UPM 3 7 UPM 4 | <ul style="list-style-type: none"> 8 Rectifier input switch (optional) 9 Battery breaker (optional) 10 MBS (optional) 11 Area for internal batteries 12 Communication cable conduit 13 Static bypass section 14 Power cable connections |
|--|--|

3.2 UPS operating modes

The UPS operating modes are as follows:

| Operating mode | Description |
|--------------------------|--|
| Normal operating modes: | |
| - Double conversion mode | Critical load is supplied by the inverter, which derives its power from rectified utility AC power. In this mode, the battery charger also provides charging current for the battery, if needed. |

| Operating mode | Description |
|---|--|
| - Variable Module Management System (VMMS) mode | Critical load is supplied by the inverter. The inverter derives its power from rectified utility AC power, identically to double conversion mode. In the VMMS mode, the 93PM UPS system is able to optimise the load level per power module: the operating efficiency is significantly improved when operating load is below 50% of UPS capacity. The UPS system will automatically place the redundant power modules to suspended mode. In case of any anomalies in utility or a sudden load increase, the suspended power modules are able to transfer to online mode with less than 2 ms transition time. |
| - Energy Saver System (ESS) mode | Critical load is supported securely by utility power through the static bypass switch with double conversion available on-demand with typically less than a 2 ms transition time, should any abnormal condition be detected in the utility. When operating in the ESS mode, the load is protected with inherent surge suppression. Operating the UPS in the ESS mode increases system efficiency up to 99%, allowing significant savings in energy losses without compromising system reliability |
| Stored energy mode | Energy is drawn from a DC backup power source and converted to AC power by the UPS inverter. Most commonly VRLA batteries are introduced to the system for this purpose, and the mode of operation is called the battery mode |
| Bypass mode | Critical load is supported directly by utility power through the UPS static switch. |

3.2.1 Normal operating modes

During normal UPS operation, power for the system is derived from a utility input source. **Unit Online** is displayed on the front panel, indicating that the incoming power is within voltage and frequency acceptance windows.

3.2.1.1 Double conversion mode

Figure 2 shows the path of electrical power through the UPS system when the UPS is operating in the double conversion mode.

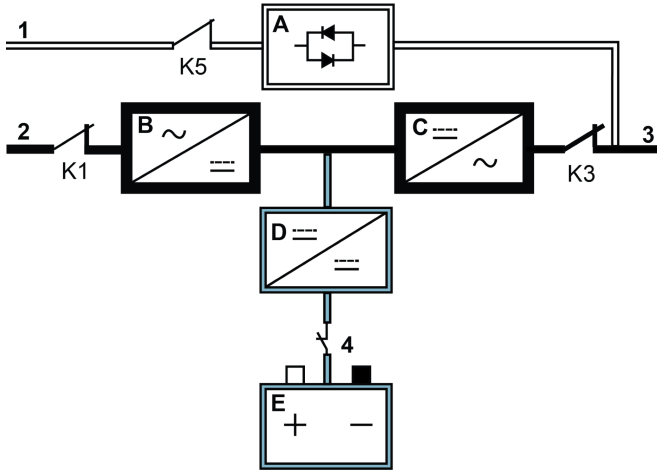

Figure 2. Path of current through the UPS in the double conversion mode

| | | | | | |
|---|-------------------|---|-----------------|--|-----------------|
| A | Static switch | 1 | Bypass input | | Main power flow |
| B | Rectifier | 2 | Rectifier input | | Energized |
| C | Inverter | 3 | Output | | De-energized |
| D | Battery converter | 4 | Battery breaker | | Trickle current |
| E | Battery | | Closed | | Open |

Three-phase AC input power is converted to DC using a multilevel converter with IGBT devices to produce a regulated DC voltage to the inverter. The UPS status indicated on the display is **Unit Online** and the UPM status is **Active**.

The battery converter derives its input from the regulated DC output of the rectifier and provides regulated charge current to the battery. The battery is always connected to the UPS and ready to support the inverter should the utility input become unavailable.

The inverter produces a three-phase AC output to the critical load. The inverter uses multilevel converter technology with IGBT devices and pulse-width modulation (PWM) to produce a regulated and filtered AC output.

If the utility AC power is interrupted or is out of specification, the UPS automatically switches to the battery mode to support the critical load without interruption. When utility power returns, the UPS returns automatically to the double conversion mode.

If the UPS becomes overloaded or unavailable, the UPS seamlessly switches to the bypass mode and continues supplying the load through the static bypass. The UPS automatically returns to the double conversion mode when the abnormal condition, such as an extended time overload, is cleared and the system operation is restored within the specified limits.

If a UPM within the UPS suffers an internal failure, the remaining UPMs continue to support the load in the double conversion mode. The UPS is automatically internally redundant when the UPS is not operating at full load. However, if internal redundancy between the UPMs is not possible due to high load, the UPS switches automatically to the bypass mode and remains in that mode until the failure is corrected and the UPS is back in operation.

In an external parallel redundant system, each UPS can be isolated from the system for service while the remaining UPSs support the load in the double conversion mode.

3.2.1.2 Variable Module Management System mode

When Variable Module Management System (VMMS) mode is enabled, the load is powered by UPMs in double conversion mode (see Figure 2). The UPS status indicated on the display is **Unit Online VMMS** and the UPM status is **Active**.

UPS efficiency varies according to the load level at which the UPS operates. VMMS technology enables achieving optimised system efficiency by automatically optimising the UPM load level. As an example, when the load is very low, a minimum of one UPM is online. This enhances the UPS system efficiency by several percentage points.

The remaining UPMs are ready to switch to double conversion mode instantaneously, if the load increases. The load will remain protected by double conversion UPS the entire time, even during and after a load step.

It is possible to configure VMMS mode to include power module redundancy at all times, so that a number of additional redundant UPMs are always online.

When the UPMs are in ready state, the IGBT converters are constantly powered, since the rectifier input and inverter output contactors are closed. The DC link is also powered. Only the IGBT gate signals are suspended. The only step needed to come out of ready state is to gate the IGBT switches. Since DC voltage is constantly present, the inverter is able to start instantaneously: the 2 ms transfer to double conversion is practically seamless.

3.2.1.3 Energy Saver System mode

Figure 3 shows the path of electrical power through the UPS system when the UPS is operating in the Energy Saver System (ESS) mode.

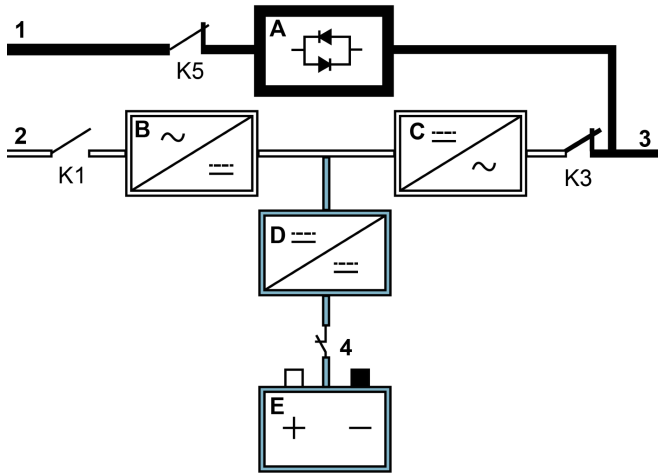

Figure 3. Path of current through the UPS in the Energy saver System mode

| | | | | | |
|---|-------------------|---|-----------------|--|-----------------|
| A | Static switch | 1 | Bypass input | | Main power flow |
| B | Rectifier | 2 | Rectifier input | | Energized |
| C | Inverter | 3 | Output | | De-energized |
| D | Battery converter | 4 | Battery breaker | | Trickle current |
| E | Battery | | Closed | | Open |
| | | | Open | | |

In the ESS mode, the UPS safely provides mains current directly to the load when the input is within the acceptable limits by its voltage and frequency. The UPS status indicated on the display is **Unit Online ESS**, and the UPM status is **Active**. Surge protection and some filtering is also provided, making sure that clean power is delivered to the load equipment. In case any disturbances are detected in the incoming power, the UPS switches to the double conversion mode and continues to supply the critical load through its inverter. In case of a complete utility outage or if the input power is outside the tolerances of the system, the UPS transfers to the battery mode and continues to supply conditioned, clean power to the critical load.

When operating in the ESS mode, the UPS's superior detection and control algorithms continuously monitor the incoming power quality and allow fast engagement of the power converters. Typical transition time to the double conversion mode is less than 2 milliseconds, which is practically seamless.

When the power conditions are within acceptable limits, the UPS operates as a high efficiency, energy-saving system, providing surge protection for IT equipment and making sure that clean power is delivered to the facility. The energy saver system increases system efficiency up to 99% when supplying 20–100% of nominal load, reducing energy losses by up to 80%.

3.2.2 Stored energy and battery mode

When running normally in the double conversion or ESS mode, the UPS automatically transfers to supply the load from batteries or some other stored energy source if a utility power outage occurs, or if the utility power does not conform to the specified parameters. The UPS status indicated on the display is **On Battery**, and the UPM status is **Active**. In the battery mode, the battery provides emergency DC power, which is converted to regulated output power by the inverter.

Figure 4 shows the path of electrical power through the UPS system when operating in the battery mode.

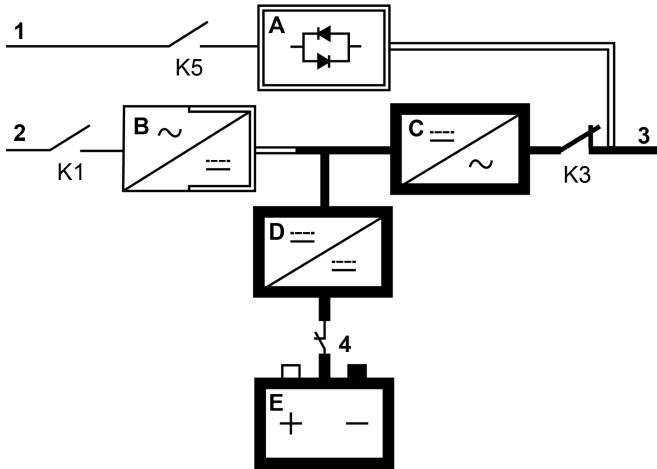







Figure 4. Path of current through the UPS in the battery mode

| | | | | | |
|---|-------------------|---|-----------------|---|-----------------|
| A | Static switch | 1 | Bypass input |  | Main power flow |
| B | Rectifier | 2 | Rectifier input |  | Energized |
| C | Inverter | 3 | Output |  | De-energized |
| D | Battery converter | 4 | Battery breaker |  | Trickle current |
| E | Battery |  | Closed |  | Open |

During a utility power failure, the rectifier no longer has an AC utility source from which to supply the DC output current required to support the inverter. The input relay K1 opens and the UPS output is powered from the batteries through the inverter. As the inverter operates uninterrupted through the transition, the load remains supported continuously without disturbance. If the UPS static bypass is supplied from the same source as the UPS rectifier, the backfeed protection contactor K5 also opens. The opening of K1 and K5 prevent system voltages from bleeding backwards and re-entering the input source through the static switch or rectifier.

If the input power fails to return or is not within the acceptance windows required for normal operation, the battery continues discharging until a DC voltage level is reached where the inverter output can no longer support the connected loads. When this event occurs, the UPS issues a set of audible and visual alarms indicating that the batteries have a minimal capacity left and a system shutdown is imminent. Unless utility power is restored, the output can be supported for a

maximum of 2 minutes before the output of the system shuts down. If the bypass source is available, the UPS transfers to the bypass mode instead of shutting down.

If the input power becomes available again at any time during the battery discharge, K1 and K5 close and the UPS returns to normal operation. The UPS also starts to recharge the batteries to restore the capacity.

3.2.3 Bypass mode



CAUTION

The critical load is not protected while the UPS is in bypass mode.

The UPS automatically switches to the bypass mode if it detects an overload, load fault, or internal failure. The bypass source supplies the commercial AC power to the load directly. The UPS can also be commanded to transfer to the bypass mode manually through the display. The UPS status indicated on the display is **On Bypass**.

The UPS will return from the bypass mode back to online mode, if the condition (for example overload) that caused the transfer is cleared. If there is a condition that will not clear by itself (for example UPS internal failure), the UPS will remain on bypass operation.

Figure 5 shows the path of electrical power through the UPS system when operating in the bypass mode.

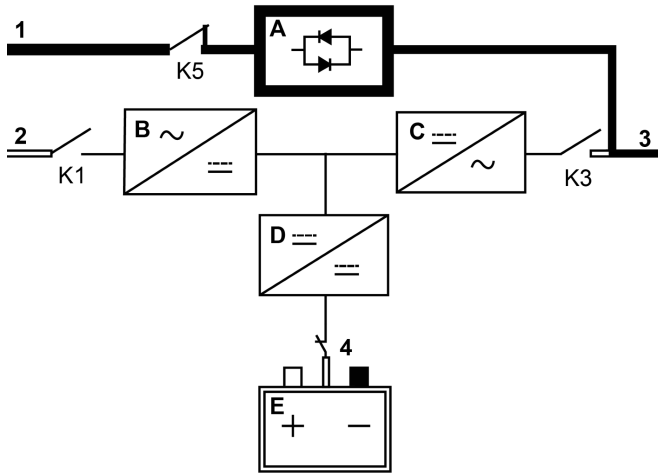

Figure 5. Path of current through the UPS in the bypass mode

| | | | | | |
|---|-------------------|---|-----------------|--|-----------------|
| A | Static switch | 1 | Bypass input | | Main power flow |
| B | Rectifier | 2 | Rectifier input | | Energized |
| C | Inverter | 3 | Output | | De-energized |
| D | Battery converter | 4 | Battery breaker | | Trickle current |
| E | Battery | | Closed | | Open |

In the bypass mode, the output of the system is provided with three-phase AC power directly from the system input. While in this mode, the output of the system is not protected from voltage or frequency fluctuations or power outages from the source. Some power line filtering and transient protection is provided to the load, but no active power conditioning or battery support is available to the output of the system in the bypass mode.

The static bypass consists of a solid-state, silicon-controlled rectifier (SCR) static switch (STSW) and a backfeed protection isolation device K5. The static switch is rated as a continuous-duty device that is used anytime the inverter is unable to support the applied load. The static switch is wired in series with the backfeed protection. As the static switch is an electronically-controlled device, it can be turned on immediately to pick up the load from the inverter without interruption. The backfeed protection is normally always closed, ready to support the static switch unless the bypass input source becomes unavailable.

3.3 UPS features

The Eaton UPS has many features that provide cost-effective and consistently reliable power protection. The feature descriptions provide a brief overview of the UPS standard features.

3.3.1 Advanced Battery Management

The Advanced Battery Management technology uses sophisticated sensing circuitry and a three-stage charging technique that extends the useful service life of UPS batteries while optimizing the battery recharge time. ABM also protects batteries from damage caused by high current charging and inverter ripple currents. Charging at high currents can overheat and damage batteries.

In the *charge mode*, the batteries are recharged. Charging lasts only as long as it takes to bring the battery system up to a predetermined float level. Once this level is reached, the UPS battery charger enters the *float stage* and the charger operates in the constant voltage mode.

The *rest mode* begins at the end of the charge mode; that is, after 48 hours of float charging (user-adjustable). In the rest mode, the battery charger is completely turned off. The battery system receives no charge current during this rest period of approximately 28 days (user-adjustable). During the rest mode, the open circuit battery voltage is monitored constantly, and battery charging is resumed when necessary.

3.3.2 Powerware Hot Sync

The Eaton Powerware Hot Sync technology is an algorithm that eliminates the single point of failure in a parallel system and therefore enhances system reliability. The Hot Sync technology is incorporated in all Eaton 93PM UPSs, and it is utilized in both multi-module internal parallel and external parallel systems.

The Hot Sync technology enables all UPMs to operate independently in a parallel system, even without inter-module communications. The power modules utilizing the Hot Sync technology are completely autonomous; each module monitors its own output independently to remain in complete synchronization with the other modules. The UPM power modules share the load perfectly even in changing capacity or load conditions.

The Powerware Hot Sync technology combines digital signal processing and an advanced control algorithm to provide automatic load sharing and selective tripping in a parallel UPS system. The load share control algorithms maintain synchronization and load balance by constantly making minute adjustments to variations in the output power requirements. The modules conform to demand and are not in conflict with each other for the load. The Powerware Hot Sync systems are capable of paralleling for both redundancy and capacity.

3.3.3 Power Conditioner

The Power Conditioner mode is characterized by the UPS running in the double conversion mode without batteries connected. In the Power Conditioner mode, the UPS provides conditioned output voltage and frequency. The UPS can also support high nonlinear loads without ITHD on the input. The UPS meets the qualifications outlined in this product specification, except for the conditions below.

When in the Power Conditioner mode, the UPS has the following functionality and limitations:

1. The UPS runs in the double conversion mode.
2. Because there is no battery, loss of utility power results in the UPS losing power and shutting down.
3. The UPS sustains up to -50% input voltage tolerance, unless the current limit is reached.
4. If the rectifier is turned off, the UPS attempts a transfer to the bypass mode.
5. The ESS mode is not available.
6. The Power Conditioner mode is available in both 3 and 4 wire configurations.

3.3.4 Frequency Converter

The Frequency Converter mode is characterized by the UPS running without the bypass mode available. The output frequency can be configured to be different from the standard input frequency (e.g. 60 Hz output, 50 Hz input). The UPS can also support high nonlinear loads without iTHD on the input. The UPS meets the qualifications outlined in this product specification, except for the conditions below.

When in the Frequency Converter mode, the UPS has the following functionality and limitations:

1. Operation is the same as when in the double conversion mode with no bypass available.
2. Bypass alarms are suppressed.

3.3.5 Sync Control

The Eaton® Sync Control maintains the critical load outputs of two separate UPS systems in synchronization. Use of the Eaton Fixed Master Sync Control provides uninterrupted transfer of the load from one load bus to another by means of downstream, dual-source, solid-state transfer switches. Without the load sync option, the two system output (critical load) buses can become out of phase with each other. This condition occurs when suitable bypass sources are not available or when the bypass sources feeding each system are not in sync with each other. Examples of this condition are two systems supplied by

separate generator sets, or situation where the bypass sources for the two systems are lost.

3.4 Software and connectivity features

3.4.1 User interface

MiniSlot Communication Bays — there are 3 communication bays for MiniSlot connectivity cards. MiniSlot cards are quickly installed and hot-pluggable. See Chapter 6 for additional information.

3.4.2 Power Management Software

Intelligent Power software products offer tools for monitoring and managing power devices across the network. See Chapter 6 for more information.

3.5 Options and accessories

Contact your Eaton sales representative for more information about the available options and accessories.

3.5.1 Maintenance Bypass Switch

The Maintenance Bypass Switch (MBS) enables power to completely bypass and isolate the UPS so that the UPS can be safely serviced or replaced without interrupting power to critical systems.

An internal maintenance bypass switch is provided as a factory installed option for 30–150 kVA units.

Alternatively, MBS solutions are also available in an external enclosure as accessory items.

External Maintenance Bypass Switch Panel

The external MBS is enclosed in its own separate cabinet, which can be either a wall-mounted or stand-alone cabinet depending on the MBS power rating. The MBS includes a Maintenance Bypass Switch (MBS) and a UPS Output Maintenance Isolation Switch (MIS). The panel may additionally include one or two input breakers: one for the rectifier input (RIB) and another for bypass input (BIB). It also includes auxiliary contacts to report the status of the switchgear to the UPS.

For external MBS installation instructions, see a separate manual.

3.5.2 93PM 200 kW SIAC-MBS

The side integrated accessory cabinet (SIAC-MBS) for 160 and 200 kW 93PM includes a mechanical maintenance bypass switch and 1 or 2 input breakers for dual or single feed installation.

3.5.3 Top air exhaust kit

The top air exhaust kit is used to direct the UPS cooling air front-to-top. The kit will eliminate the cooling clearance requirement from the back of the unit, and enable installing the UPS even against a wall, in a corner or back-to-back. The kit increases the depth of the unit by 200 mm.

Refer to Section [4.3](#) for further information.

3.5.4 Top cable access kit

The top cable access kit is designed to support top cabling to the 30-150 kVA 93PM UPS in sites where the cabling is distributed through overhead cable trays. The kit is installed at the right hand side of the UPS unit.

The 160-250 kVA 93PM UPS does not require this kit, since the unit supports bottom, rear, and top cable entry by standard.

Refer to Section [4.3](#), Section [5.1](#) and Figure [14](#) for further information.

3.5.5 Single feed kit

The Eaton 93PM UPS is configured for dual feed by standard, requiring a separate feed for rectifier and static bypass input. Single feed kits are available for 80-250 kVA models for on-site installation. In addition, a single feed configuration can be fitted to the 30-60 kVA models using jumper-cables during installation.

3.5.6 Separate battery option

By standard, the Eaton 93PM UPS has one external battery connection, through which external batteries supply all UPMs. If needed, the external battery connections can be ordered as a separate battery configuration for the multi-modular 80–200 kW models, excluding the 120 kVA, 180 kVA and 250 kVA models. This option enables connecting a separate external battery to each 50 kW UPM. See Section [5.4.1](#) for more information.

3.5.7 Field Installed UPM

A Field Installed UPM (F-UPM) can be installed in the cabinet any time in the future when power needs change. This enables the UPS system to grow with the business, thus lowering the initial investment necessary for the system on day one.

In order to install an F-UPM, the UPS cabinet needs to have upgradeability, which is determined by the power rating of the static bypass. For example, if the static bypass is rated for 150 kW, the fourth UPM cannot be installed into the frame.

For a listing of the upgradeable configurations, see [Table 2](#).

CAUTION



Only qualified service personnel are allowed to install a F-UPM.



Note: Examine the cable and fuse rating before power upgrading.

3.6 Battery system

The battery system provides short-term emergency backup power to safeguard operation during brownouts, blackouts, and other power interruptions. By default, this UPS is configured to use VRLA batteries. If other type of batteries or other energy storage means need to be connected, consult a certified service technician prior to proceeding with the installation.

93PM 30-60 kVA units

The Eaton 93PM 30–60 kVA UPS can be equipped with internal batteries to provide full load runtime of 10–20 minutes depending on the UPS rating. In addition, external battery cabinets can be introduced to the system to allow extended autonomy. Internal and external batteries can be used in parallel.

93PM 80–250 kVA units

The Eaton 93PM 80-250 kVA UPS can be equipped with an external battery system. Eaton offers external battery cabinets to be used together with Eaton 93PM UPS.

For detailed battery specifications, see [Section 9.5](#).

3.6.1 UPS Battery Switchgear

The purpose of the UPS Battery Switchgear is to ease the installation of external battery cabinets or battery racks. The UPS Battery Switchgear offering contains models with one main battery breaker and casing, as well as models that support connecting several battery cabinets or racks in parallel. In the multi-breaker solutions, the main breaker is rated to match the UPS's power and the dedicated battery string breakers can be sized either with or without redundancy.

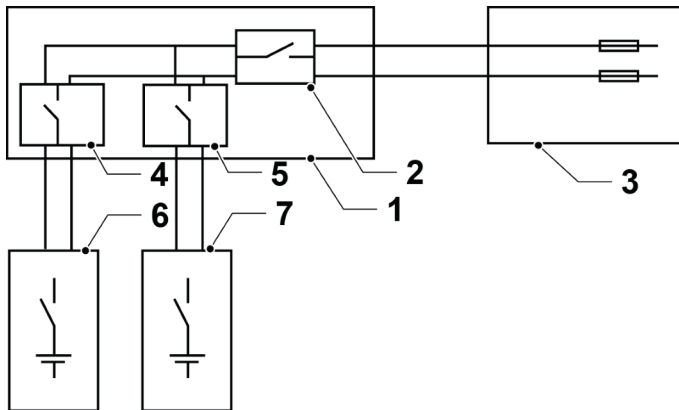

Figure 6. UPS Battery Switchgear cabling diagram

- | | | | |
|---|-----------------------------|---|-------------------|
| 1 | External Battery Switchgear | 5 | String breaker n |
| 2 | Breaker | 6 | Battery cabinet 1 |
| 3 | UPS | 7 | Battery cabinet n |
| 4 | String breaker 1 | | |

3.7 Basic system configurations

UPS power rating

The maximum attainable UPS system power rating is determined by the size of the UPS cabinet frame. The number of UPM power modules determines the nominal power rating of the UPS. If upgradeability is required, the system static bypass should be chosen according to the future maximum load rating, and the number of UPMs is chosen according to the capacity requirements on day one.

The following UPS configurations with different static bypass sizes and number of UPMs are possible:

Table 2: UPS configurations

| Description | System power [kW] | Rated output power factor | Power modules [kW] | Static switch [kW] | Internal battery |
|--------------|-------------------|---------------------------|--------------------|--------------------|------------------|
| 93PM-30(50) | 30 | 1.0 | 1x30 | 50 | Yes/No |
| 93PM-40(50) | 40 | 1.0 | 1x40 | 50 | Yes/No |
| 93PM-50(50) | 50 | 1.0 | 1x50 | 50 | Yes/No |
| 93PM 40(100) | 40 | 1.0 | 1x40 | 100 | No |

| Description | System power [kW] | Rated output power factor | Power modules [kW] | Static switch [kW] | Internal battery |
|------------------|----------------------|------------------------------|-----------------------|-----------------------|------------------|
| 93PM 40(150) | 40 | 1.0 | 1x40 | 150 | No |
| 93PM 40(200) | 40 | 1.0 | 1x40 | 200 | No |
| 93PM 40+40(100) | 40 | 1.0 | 2x40 | 100 | No |
| 93PM-50(100) | 50 | 1.0 | 1x50 | 100 | No |
| 93PM 50(150) | 50 | 1.0 | 1x50 | 150 | No |
| 93PM 50(200) | 50 | 1.0 | 1x50 | 200 | No |
| 93PM 50+50(100) | 50 | 1.0 | 2x50 | 100 | No |
| 93PM 80(100) | 80 | 1.0 | 2x40 | 100 | No |
| 93PM 80(150) | 80 | 1.0 | 2x40 | 150 | No |
| 93PM 80(200) | 80 | 1.0 | 2x40 | 200 | No |
| 93PM 80+40(150) | 80 | 1.0 | 3x40 | 150 | No |
| 93PM 100(100) | 100 | 1.0 | 2x50 | 100 | No |
| 93PM 100(150) | 100 | 1.0 | 2x50 | 150 | No |
| 93PM 100(200) | 100 | 1.0 | 2x50 | 200 | No |
| 93PM 100+50(150) | 100 | 1.0 | 3x50 | 150 | No |
| 93PM 120(150) | 120 | 1.0 | 3x40 | 150 | No |
| 93PM 120(200) | 120 | 1.0 | 3x40 | 200 | No |
| 93PM 120+40(200) | 120 | 1.0 | 4x40 | 200 | No |
| 93PM 150(150) | 150 | 1.0 | 3x50 | 150 | No |
| 93PM 150(200) | 150 | 1.0 | 3x50 | 200 | No |
| 93PM 150+50(200) | 150 | 1.0 | 4x50 | 200 | No |
| 93PM 160(200) | 160 | 1.0 | 4x40 | 200 | No |
| 93PM 200(200) | 200 | 1.0 | 4x50 | 200 | No |
| 93PM-60(60) | 60 | 0.9 | 1x60 | 60 | Yes/No |
| 93PM-60(120) | 60 | 0.9 | 1x60 | 120 | No |
| 93PM-60(250) | 60 | 0.9 | 1x60 | 250 | No |
| 93PM-60+60(120) | 60 | 0.9 | 2x60 | 120 | No |
| 93PM-120(120) | 120 | 0.9 | 2x60 | 120 | No |
| 93PM-120(150) | 120 | 0.9 | 2x60 | 250 | No |
| 93PM-120+60(250) | 120 | 0.9 | 3x60 | 250 | No |
| 93PM-180(250) | 180 | 0.9 | 3x60 | 250 | No |
| 93PM-180+60(250) | 180 | 0.9 | 4x60 | 250 | No |
| 93PM-250(250) | 250 | 0.9 | 4x62,5 | 250 | No |

The UPS frames can be connected in parallel to create even larger systems. A maximum of eight UPSs can be connected in parallel.

UPS options and accessories

The following table shows different standard and optional UPS features and the models where they apply.

Table 3: Standard and optional UPS features

| Feature | 30–50 kW, 60 kVA | 80–100 kW | 120 kVA | 120–150 kW | 160–200 kW | 180–250 kVA |
|---|------------------|-----------|----------|------------|------------|-------------|
| Smart touch screen display for system control and monitoring | Standard | Standard | Standard | Standard | Standard | Standard |
| Internal MBS | Option | Option | Option | Option | – | – |
| Rectifier input switch | Standard | Option | – | Option | – | – |
| Internal battery breaker | Standard | Option | Option | Option | – | – |
| Top air exhaust kit | – | Option | Option | Option | Option | – |
| Top cable access kit | Option | Option | Option | Option | Standard | Option |
| Battery start | Standard | Standard | Option | Standard | Standard | Standard |
| Integrated backfeed protection | Standard | Standard | Standard | Standard | Standard | Standard |
| Side integrated accessory cabinet MBS | – | – | Standard | – | Option | Standard |
| Single feed kit | – | Option | Option | Option | Option | Option |
| Separate battery | – | Option | – | Option | Option | – |

Additional options and accessories are also available. These include different software and connectivity options and external switchgear and power distribution options.

4 UPS installation plan and unpacking

Use the following basic sequence of steps to install the UPS:

1. Create an installation plan for the UPS system.
2. Prepare your site for the UPS system.
3. Inspect and unpack the UPS cabinet.
4. Unload and install the UPS cabinet and wire the system.
5. Complete the installation checklist provided in Section [4.2](#).
6. Have authorized service personnel perform the preliminary operational checks and startup.



Note: Startup and operational checks must be performed by an authorized Eaton Customer Service Engineer or by other qualified service personnel authorized by Eaton, or the terms specified in the Warranty (see Chapter [10](#)) become void. This service is offered as a part of the sales contract for the UPS. Contact service in advance (usually a two-week notice is required) to reserve a preferred startup date.

4.1 Creating an installation plan

Before you install the UPS system, read and understand how these instructions apply to the system that you are going to install. Use the procedures and illustrations in Section [4.3](#) and Chapter [5](#) to create a logical plan for installing the system.

4.2 Installation checklist

| Action | Yes / No |
|--|----------|
| All packing materials and restraints are removed from each cabinet. | |
| Each cabinet in the UPS system is placed in its installed location. | |
| A cabinet grounding kit / mounting kit is installed between any cabinets that are bolted together. | |
| All conduits and cables are properly routed to the UPS and any ancillary cabinets. | |
| All power cables are properly sized and terminated. | |
| Neutral conductors are installed and bonded to ground according to the requirements. | |
| A ground conductor is properly installed. | |
| Battery cables are terminated and connected to battery connectors. | |
| Battery Shunt trip and Aux contact signal wiring is connected from the UPS to the battery breaker. | |
| LAN drops are installed. | |
| All LAN connections are completed. | |
| Air conditioning equipment is installed and operating correctly. | |
| There is sufficient workspace around the UPS and other cabinets. | |
| Sufficient lighting is provided around all the UPS equipment. | |
| A 230 VAC service outlet is located within 7.5 meters of the UPS equipment. | |
| The Remote Emergency Power-off (REPO) device is mounted in its installed location and its wiring is terminated inside the UPS cabinet. | |
| If EPO is used in the NC configuration, a jumper is installed on the EPO between pins 1 and 2. | |
| (OPTIONAL) Alarm relays and signal outputs are wired appropriately. | |
| (OPTIONAL) A remote battery disconnect control is mounted in its installed location and its wiring is terminated inside the UPS and battery cabinet. | |
| (OPTIONAL) Accessories are mounted in their installed locations and their wiring is terminated inside the UPS cabinet. | |
| Start-up and operational checks are performed by an authorized Eaton Customer Service Engineer. | |

4.3 Site preparations

For the UPS system to operate at peak efficiency, the installation site must meet the environmental parameters outlined in these instructions. If the UPS needs to be operated at an altitude higher than 1,000 m, contact your service representative for important information about high altitude operation. The

operating environment must meet the height, clearance, and environmental requirements specified.

4.3.1 Environmental and installation considerations

The UPS system can be installed where there is TN, TT, or IT power distribution system.

- Install the system indoors on a level floor suitable for computer or electronic equipment. The floor must be suitable for heavy weight and wheeling.
- Install the system in a temperature and humidity controlled area, where the dew point cannot be reached.
- Install the system in an area that is free of conductive contaminants.
- Install the cabinet either in line-up-and-match or standalone configurations.

If you do not obey these guidelines your warranty could become void.

The UPS equipment operating environment must meet the weight requirements shown in Table 4, and the size requirements shown in Table 5.

Table 4: UPS cabinet maximum weights

| | 30–50 kW, 60 kVA* | 80–100 kW, 120 kVA | 120–150 kW | 160–200 kW, 180–250 kVA |
|---|----------------------|-----------------------|---------------|----------------------------|
| Shipping weight [kg] | 910 | 380 | 490 | 590 |
| Installed weight [kg] | 860 | 330 | 405 | 535 |
| Floor loading [kg/m²] | 1760 | 640 | 790 | 1050 |

* Note that with 30–50kW and 60kVA models, the maximum number of internal batteries are included. Shipping weights may be lower based on accessories installed into UPS.

Table 5: UPS cabinet dimensions

| Dimensions (W x D x H) | 30–150 kVA [mm] | 160–250 kVA [mm] | 160–200 kW with Side Integrated Accessory Cabinet MBS [mm] |
|----------------------------|----------------------|----------------------|---|
| Shipping dimensions | 750 x 1135 x 2050 | 900 x 1135 x 2035 | 1090 x 1135 x 2050 |
| Cabinet dimensions | 560 x 914 x 1876 | 760 x 914 x 1876 | 966 x 914 x 1876 |

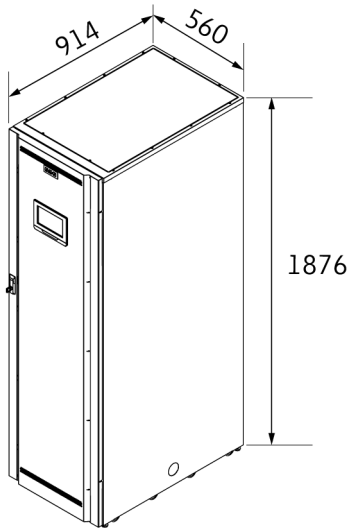

Figure 7. Dimensions of 93PM 30-60 kVA UPS

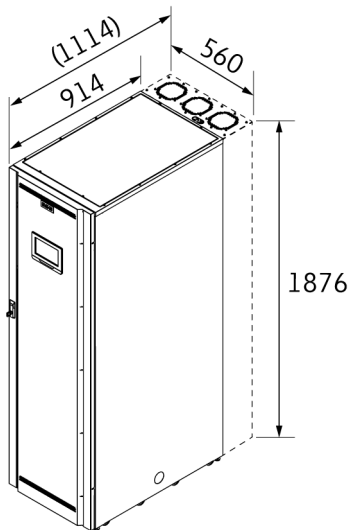

Figure 8. Dimensions of 93PM 80-150 kVA UPS

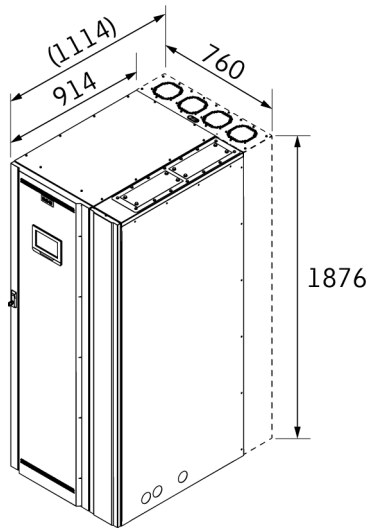

Figure 9. Dimensions of 93PM 160-250 kVA UPS

The UPS cabinets use forced air cooling to regulate internal component temperature. By standard, air inlets are in the front of the cabinet and outlets are in the back. You must allow clearance in front of and behind each cabinet for proper air circulation.

With the optional top air exhaust kit, it is possible to configure the air outlets in the top rear of the cabinet. With this option, the UPS can be installed against a wall or back-to-back. See Figure 10 for illustration of 93PM air outlets.

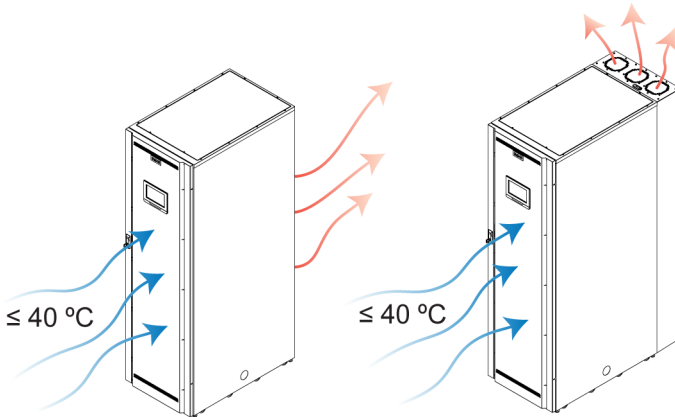

Figure 10. 93PM air outlets

The clearances required around the UPS cabinet in both of these situations are shown in Table 6.

Table 6: UPS cabinet clearances

| | 30–50 kW, 60 kVA [mm] | 80–100 kW, 120 kVA [mm] | 120–200 kW, 180–250 kVA [mm] | 80–250 kVA with top air exhaust kit [mm] |
|-------------------------------|-----------------------------|-------------------------------|---------------------------------------|---|
| From the top of the cabinet | 500 | 500 | 500 | 500 |
| From the front of the cabinet | 900 | 900 | 900 | 900 |
| From the back of the cabinet | 200* | 200* | 300* | 0 |
| From the side of the cabinet | 0 | 0 | 0 | 0* |

* Cabling may require more space.

See details of installation environment requirements in Section 9.4.

It is required to arrange ventilation of the UPS room. Sufficient amount of air cooling is needed to keep the maximum room temperature rise at desired level:

- Temperature rise of max. +5 °C requires the airflow of 600 m³/h per 1 kW of losses
- Temperature rise of max. +10 °C requires the airflow of 300 m³/h per 1 kW of losses

An ambient temperature from +20 to +25 °C is recommended to achieve a long life of the UPS and batteries. Avoid high ambient temperature, moisture, and humidity.

For ventilation requirements, see 93PM heat rejection in the following table:

Table 7: Air conditioning or ventilation requirements during full load operation

| Rating | Heat rejection (BTU/h x 1,000) | Heat rejection [kW] |
|---------|-----------------------------------|------------------------|
| 30 kW | 3,6 | 1,1 |
| 40 kW | 4,9 | 1,5 |
| 50 kW | 6,6 | 1,9 |
| 80 kW | 9,6 | 2,8 |
| 100 kW | 12,7 | 3,7 |
| 120 kW | 14,0 | 4,1 |
| 150 kW | 18,9 | 5,5 |
| 160 kW | 19,2 | 5,6 |
| 200 kW | 25,5 | 7,5 |
| 60 kVA | 7,5 | 2,2 |
| 120 kVA | 14,2 | 4,2 |
| 180 kVA | 21,2 | 6,2 |
| 250 kVA | 29,5 | 8,7 |

4.3.2 UPS system power wiring preparations



Note: If you are installing a maintenance bypass, provide one of the following:

- a minimum of 2 separate feeds with upstream feeder breakers or
- a single feed with 2 upstream feeder breakers: one for the UPS or rectifier input breaker (if installed) and one for the maintenance bypass input.

Do not use a single feed or a single feeder breaker to supply both

- the UPS or rectifier input breaker and
- the maintenance bypass.

If a bypass input breaker is installed in the maintenance bypass and a single-feed UPS is being installed, a single feed to the maintenance bypass is acceptable for supplying both the UPS and the bypass.

When you plan and perform the installation, read and understand the following notes:

- Refer to national and local electrical codes for acceptable external wiring practices.

- To allow for future kVA upgrades (software and/or hardware), consider using conductors sized for full bypass rating of the UPS.
- Material and labor for external wiring requirements must be provided by designated personnel.
- For external wiring, use copper cable rated for 70 °C at minimum. See the appropriate information in Tables 8 and 9. Cable sizes are based on using the specified breakers.
- If cables are run in an ambient temperature greater than 30 °C, higher temperature cable and/or larger size cable may be necessary.
- The bypass feed into this equipment uses three phases or three phases and neutral. The rectifier feed into this equipment uses three phases or three phases and neutral. The phases must be symmetrical about ground (from a Wye source) for proper equipment operation.
- If the load requires a neutral, a bypass source neutral must be provided. If the load does not require a neutral and there is no neutral conductor connected at the bypass input, a neutral must be installed to source star point.
- A readily accessible disconnect device must be incorporated in all fixed input wiring.

WARNING



Do not disconnect the bypass neutral without disconnecting the bypass phases at the same time.

Table 8: Minimum recommended multi-core cable and fuse sizes for rectifier input, bypass input and UPS output connections

| UPS rating | Phase cables [mm ²] | Rectifier and bypass input fuse [A] | PE cable [mm ²] |
|------------|---------------------------------|-------------------------------------|-----------------------------|
| 30 kW | 1x16 | 63 | 1x16 |
| 40 kW | 1x25 | 80 | 1x16 |
| 50 kW | 1x35 | 100 | 1x16 |
| 80 kW | 1x70 | 160 | 1x35 |
| 100 kW | 1x95 | 200 | 1x50 |
| 120 kW | 1x120 | 250 | 1x70 |
| 150 kW | 1x150 | 315 | 1x95 |
| 160 kW | 1x185 | 315 | 1x95 |
| 200 kW | 1x240 | 400 | 1x120 |
| 60 kVA | 1x35 | 125 | 1x16 |
| 120 kVA | 1x120 | 250 | 1x70 |
| 180 kVA | 2x70 | 315 | 1x70 |
| 250 kVA | 2x120 | 400 | 1x120 |

CAUTION

Make sure that prospective short-circuit current resulting at the input terminals of the UPS is equal or less than conditional short-circuit current declared on the type plate of the UPS.

Table 9: Minimum recommended multi-core cable and fuse sizes for battery connection

| UPS rating | Battery cable, pos. & neg. line [mm ²] | Battery fuse [A] |
|------------|--|------------------|
| 30 kW | 1 x 35 | 160 or 200 |
| 40 kW | 1 x 35 | 160 or 200 |
| 50 kW | 1 x 50 | 200 |
| 80 kW | 2 x 35 | 400 |
| 100 kW | 2 x 50 | 400 |
| 120 kW | 2 x 70 | 500 |
| 150 kW | 2 x 95 | 500 |
| 160 kW | 2 x 120 | 630 |
| 200 kW | 2 x 120 | 630 |
| 60 kVA | 1 x 50 | 200 |
| 120 kVA | 2 x 70 | 400 |
| 180 kVA | 2 x 95 | 630 |
| 250 kVA | 2 x 150 | 630 |



Note: UPS power upgrading is possible only if the sizing of the external cables is sufficient. Alternatively, the external cabling must be upgraded as well.



Note: Make sure there is sufficient DC voltage and interrupt rating of the protective device. Make sure that the available short circuit current of the batteries is sufficient for the selected component.



Note: The above sizing is recommended for the main battery fuse or breaker. The rating of the protective device for a single battery string may be smaller than this.



Note: Cable sizing is based on the standard IEC 60364-5-52 table B.52.2 and IEC 60364-5-54 table B.54.2. Sizing is for 70 °C rated copper cables.

Table 10: Rated and maximum currents for rated power and voltage, rectifier input and UPS output / bypass

| Rated power [kVA] | Rated power [kW] | Rated voltage [V] | Rectifier input | | UPS output / bypass Rated current [A] |
|-------------------|------------------|-------------------|-------------------|---------------------|--|
| | | | Rated current [A] | Maximum current [A] | |
| 30 | 30 | 380 | 59 | 57 | 46 |
| | | 400 | 56 | 57 | 43 |
| | | 415 | 54 | 57 | 42 |
| 40 | 40 | 380 | 75 | 76 | 61 |
| | | 400 | 71 | 76 | 58 |
| | | 415 | 68 | 76 | 56 |
| 50 | 50 | 380 | 91 | 95 | 76 |
| | | 400 | 86 | 95 | 72 |
| | | 415 | 83 | 95 | 70 |
| 80 | 80 | 380 | 140 | 152 | 122 |
| | | 400 | 133 | 152 | 115 |
| | | 415 | 128 | 152 | 111 |
| 100 | 100 | 380 | 172 | 190 | 152 |
| | | 400 | 163 | 190 | 144 |
| | | 415 | 157 | 190 | 139 |
| 120 | 120 | 380 | 204 | 228 | 182 |
| | | 400 | 194 | 228 | 173 |
| | | 415 | 187 | 228 | 167 |
| 150 | 150 | 380 | 252 | 285 | 228 |
| | | 400 | 239 | 285 | 217 |
| | | 415 | 231 | 285 | 209 |
| 160 | 160 | 380 | 268 | 304 | 243 |
| | | 400 | 255 | 304 | 231 |
| | | 415 | 245 | 304 | 223 |
| 200 | 200 | 380 | 332 | 380 | 304 |
| | | 400 | 315 | 380 | 289 |
| | | 415 | 304 | 380 | 278 |
| 60 | 54 | 380 | 102 | 101 | 91 |
| | | 400 | 97 | 101 | 87 |
| | | 415 | 93 | 101 | 83 |

| Rated power [kVA] | Rated power [kW] | Rated voltage [V] | Rectifier input | | UPS output / bypass Rated current [A] |
|-------------------|------------------|-------------------|-------------------|---------------------|---------------------------------------|
| | | | Rated current [A] | Maximum current [A] | |
| 120 | 108 | 380 | 198 | 202 | 182 |
| | | 400 | 189 | 202 | 173 |
| | | 415 | 182 | 202 | 167 |
| 180 | 162 | 380 | 294 | 302 | 273 |
| | | 400 | 280 | 302 | 260 |
| | | 415 | 270 | 302 | 250 |
| 250 | 225 | 380 | 406 | 420 | 380 |
| | | 400 | 386 | 420 | 361 |
| | | 415 | 372 | 420 | 348 |

**Note:**

1. Rectifier input rated current: Nominal power, 100% load with full battery charging.
2. Rectifier input maximum current: Rectifier current limit.
3. UPS output / bypass rated current: Nominal, 100% rated load.

Table 11: Rated and maximum currents for rated power and voltage, battery

| UPS rating [kVA] | Rated power [kW] | Battery | |
|------------------|------------------|-------------------|----------------------|
| | | Rated current [A] | Maximum current* [A] |
| 30 | 30 | 74 | 95 |
| 40 | 40 | 99 | 127 |
| 50 | 50 | 123 | 141 |
| 80 | 80 | 177 | 253 |
| 100 | 100 | 222 | 281 |
| 120 | 120 | 266 | 380 |
| 150 | 150 | 332 | 422 |
| 160 | 160 | 355 | 507 |
| 200 | 200 | 443 | 563 |
| 60 | 54 | 133 | 152 |
| 120 | 108 | 239 | 274 |
| 180 | 162 | 359 | 410 |
| 250 | 225 | 499 | 570 |

| UPS rating [kVA] | Rated power [kW] | Battery | |
|--|------------------|-------------------|----------------------|
| | | Rated current [A] | Maximum current* [A] |
| *) Maximum battery current calculated at rated load and 1.75 V cell voltage for minimum battery string length. | | | |

Table 12: UPS power cable terminations

| Terminal function | Terminal | Function |
|---------------------------------------|----------|----------------------|
| AC input to UPS rectifier | X1 | L1, L2, L3, N |
| AC input to bypass | X2 | L1, L2, L3, N |
| UPS output | X3 | L1, L2, L3, N |
| DC input from external battery to UPS | X4 | battery +, battery - |
| Protective Earth | PE | PE |



Note: External overcurrent protection is not provided by this product, but is required by codes. Refer to Tables 8 and 9 for wiring requirements. If an output lockable disconnect is required, it is to be supplied by the user.

Table 13: UPS power cable terminal bolt torques

| UPS frame | Function | Tightening torque [Nm] | Bolt size |
|------------------|--------------------|------------------------|-----------|
| 93PM 30–60 kVA | X1: L1, L2, L3, X4 | 14 | – |
| | X1: N, X2, X3 | 12 | – |
| | PE | 3 | – |
| 93PM 80–150 kVA | L1, L2, L3, N | 47 | M10 |
| | PE | 24 | M8 |
| 93PM 160–250 kVA | L1, L2, L3, N | 80 | M12 |
| | PE | 47 | M10 |

CAUTION



To reduce the risk of a fire, connect only to a circuit that is provided with maximum input circuit breaker current ratings from Table 10 and Table 11 in accordance with the national and local installation rules.

The line-to-line unbalanced output capability of the UPS is limited only by the full load per phase current values for AC output to critical load shown in Tables 10 and 11. The recommended line-to-line load unbalance is 50% or less.

Source protection for the AC input to bypass must suit the characteristics of the load and take into account effects such as inrush or starting current.

Bypass and output overcurrent protection and bypass and output disconnect switches must be provided by the user.

4.4 Unpacking and unloading the UPS

Before you start to unpack and unload the UPS, examine the TipNTell indicator on the package surface and the DropNTell indicator on the UPS after unpacking (see step 2 below). If the equipment has been correctly transported in the upright position, the indicator should be intact. If the indicator arrow has turned all blue, contact the appropriate parties to report inappropriate transportation.

WARNING



The UPS cabinet is heavy. If you do not obey the unpacking instructions, the cabinet can tip over and cause serious injury.

Do not tilt the UPS cabinet more than 10 degrees from the vertical or the cabinet can tip over.

For transportation purposes, the UPS cabinet is bolted onto a wooden pallet. To remove the pallet:

1. Before you unload the cabinet from the pallet, use a forklift or other material handling equipment to move the cabinet to the installation area. Insert the forks of the forklift between the skids on the bottom of the unit.

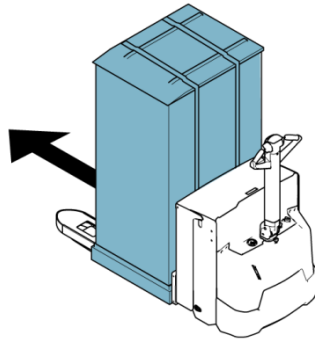

2. Make a visual inspection to make sure that there are no signs of shipping damages. Examine the indicators. See the instructions next to the indicators on the package.

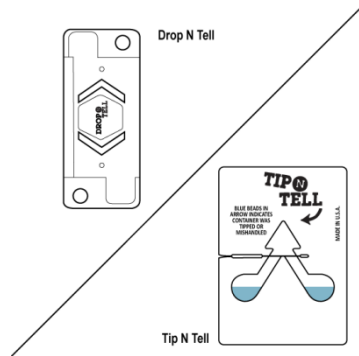

3. Open the UPS package and remove the ramp attached to the side of the package by forcing the locking pieces to open. There are locking pieces in the corners of the package and similar locking pieces hold the ramp in place.

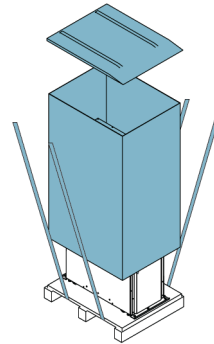

4. Place the ramp on the floor and attach it to the pallet with nails or screws so that it can be safely used for wheeling the UPS off the pallet.

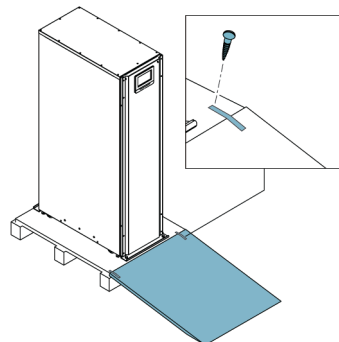

5. If the leveling feet are not fully retracted, turn them until they are retracted.

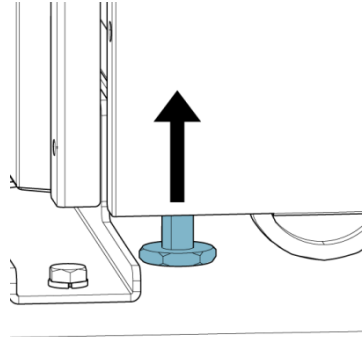

6. Open the cabinet door.

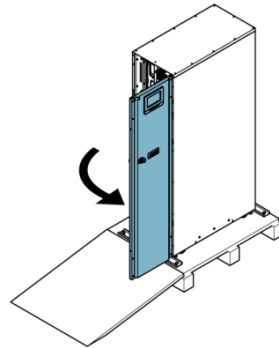

7. Remove the bolts that fasten the shipping brackets to the cabinet and to the pallet.
8. Remove the shipping brackets.

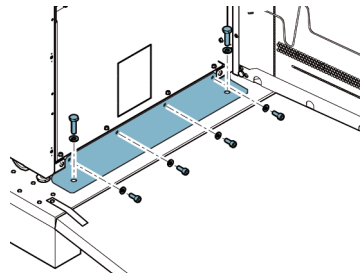

Note: After you have removed the shipping brackets, move the unit immediately away from the pallet.

After you have removed the shipping brackets and retracted the leveling feet, do not use a forklift to move the unit while it is still on the pallet. Note that the UPS cabinet is heavy and there are casters under the cabinet.

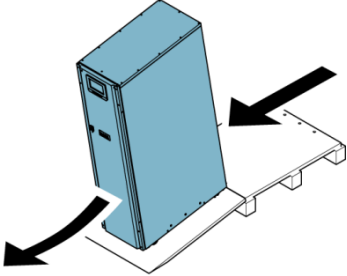
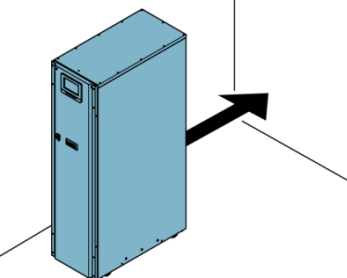
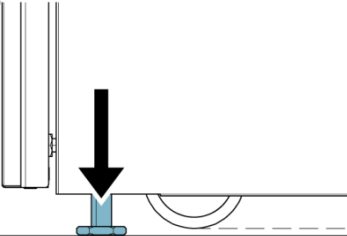
| | |
|--|--|
| <p>9. Slowly roll the cabinet toward the ramp edge. Do not push the cabinet too much or too fast because the cabinet can tip over. Note that the cabinet is heavy. Make sure that you have enough manpower to handle and support the unit while rolling it off the pallet.</p> |  |
| <p>10. Roll the cabinet to its final installation location.</p> |  |
| <p>11. To secure the UPS cabinet in position, lower the leveling feet until the cabinet is not resting on the casters and the cabinet is level.</p> |  |



Note: If you remove the cabinet from its original installation location and transfer it to a new location on a pallet, lower the leveling feet until the cabinet is not resting on the casters. In addition, attach the shipping brackets to the cabinet and the pallet.

5 UPS system installation

The operator has to supply the wiring to connect the UPS to the local power source. The installation of the UPS must be made by a locally qualified electrician. The electrical installation procedure is described in the following section. The installation inspection and the initial start-up of the UPS and installing an extra battery cabinet must be carried out by an authorized Eaton Customer Service Engineer or by other qualified service personnel authorized by Eaton.



CAUTION

To avoid physical injury or death, or damage to the UPS or the load equipment, follow these instructions during the UPS system installation.



CAUTION

In case of condensed moisture inside the UPS cabinet, dry the cabinet with a blower before starting up the system.

5.1 Installing the UPS

1. Open the UPS door.

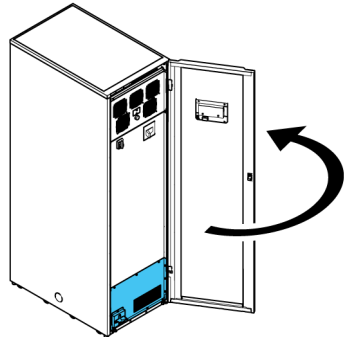

2. Remove the safety shield to gain access to power cable terminals.

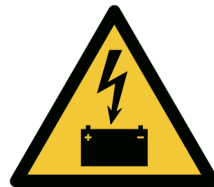

3. **For 30-60 kVA frame:** Remove the screw securing the MBS protection cover on bottom left of the front panel.
4. Loosen the screw in the middle of the knob and pull the knob off the shaft.

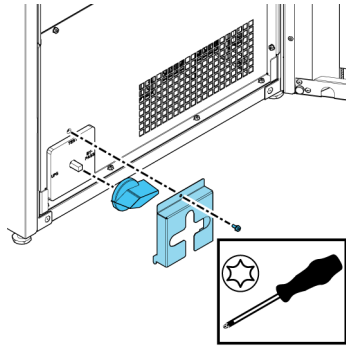

5. Remove the screws and pull out the safety shield panel in front of the connectors.

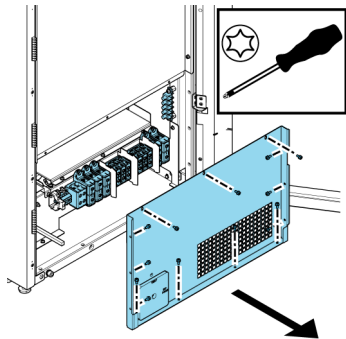

6. **For 80-150 kVA frame:** Remove the screws and pull out the safety shield panel in front of the connectors.

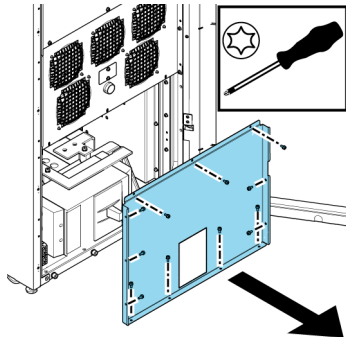

7. **For 160-250 kVA frame:**
Remove the cover panel (1) by removing the screw and lifting the cover panel. Remove the screws and pull out the safety shield panel (2) in front of the connectors.

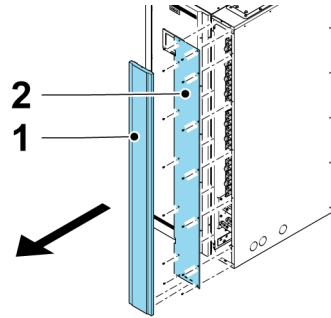

8. **For 30-60 kVA frame:** Locate and remove the screws from the relevant cable gland plates for installing the power cables.

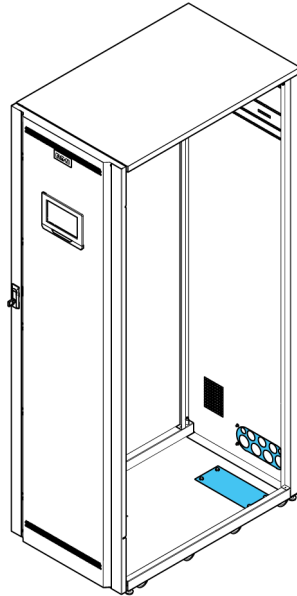

9. **For 80-150 kVA frame:** Locate and remove the screws from the relevant cable gland plates for installing the power cables.

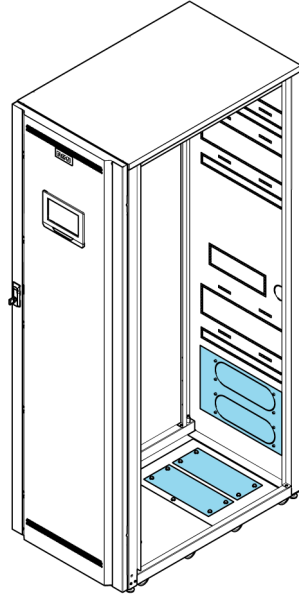

10. **For 160-250 kVA frame:** Locate and remove the screws from the relevant cable gland plates for installing the power cables.

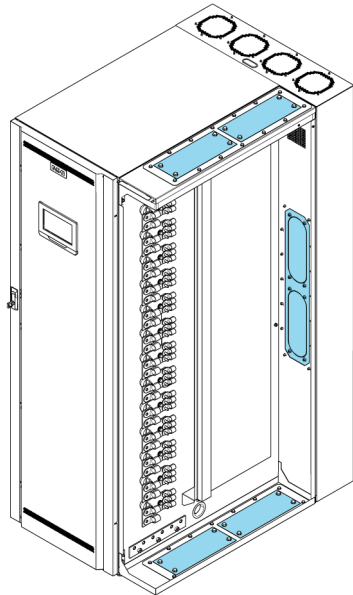

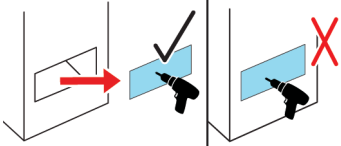
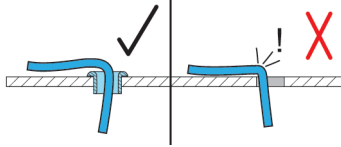
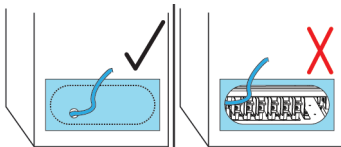
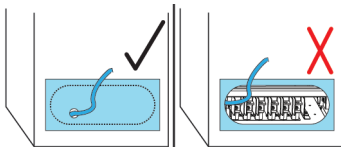
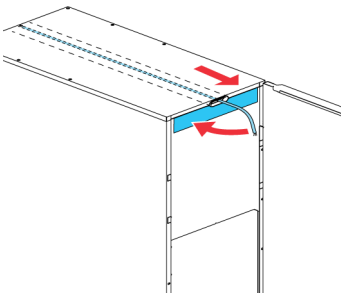
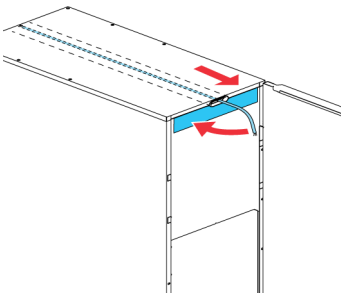
| | |
|--|--|
| <p>11. Drill or punch holes for the cable glands on the plate used for cable entry.</p> <p>Do the work while the plate is outside the UPS cabinet to prevent metal shavings or chips from entering into electronics.</p> |  |
| <p>12. Install suitable cable glands on the plate.</p> |  |
| <p>13. Route all cables through the wire way to the UPS terminal blocks.</p> |  |
| <p>14. Reinstall the wire entry plate and install conduit if needed.</p> |  |
| <p>15. Connect power wiring to the terminals and tighten to the right torque. See Table 14.</p> <p>16. When all power wiring is complete, reinstall the safety shield panels.</p> |  |
| <p>17. For installing the control wiring, use the communication cable conduit to route the cables to the communication terminals.</p> |  |

If you install a parallel system, repeat the above steps to all units in the system.

5.2 Connector and power cable terminal locations

The list of connectors and power cable terminal locations is applicable to all 93PM 30-250 kVA UPS models.

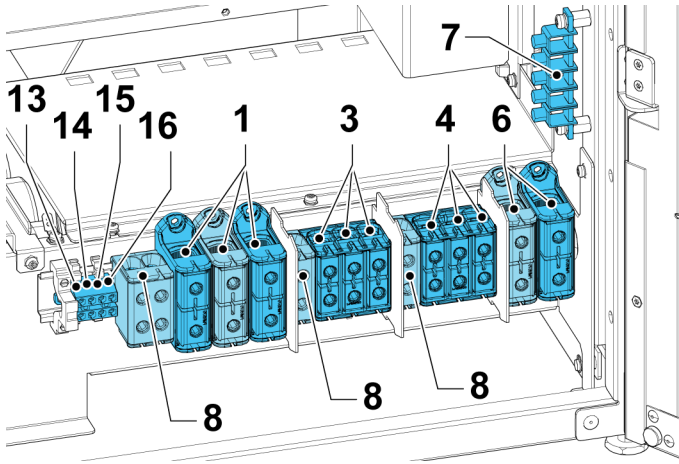

Figure 11. 93PM 30–60 kVA connectors and power cable terminals

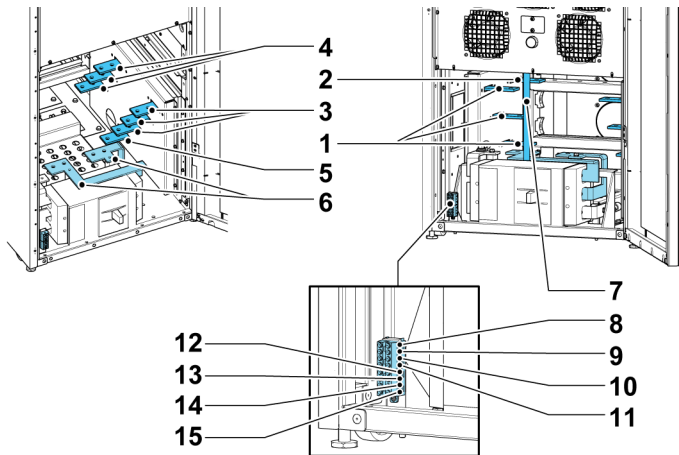

Figure 12. 93PM 80–150 kVA connectors and power cable terminals

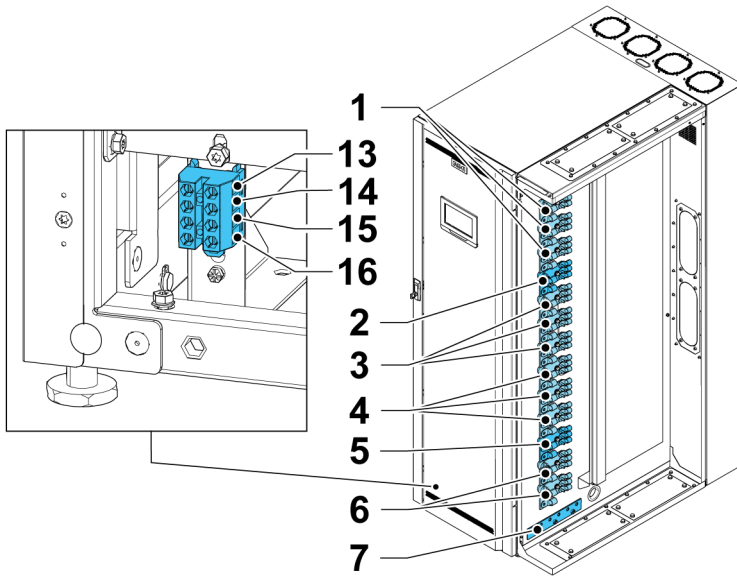

Figure 13. 93PM 160–250 kVA UPS connectors and power cable terminals

| | | | |
|---|---|----|------|
| 1 | X1: rectifier input L1-L3 | 9 | X5:1 |
| 2 | X1: neutral for rectifier input | 10 | X5:2 |
| 3 | X2: bypass input L1-L3 | 11 | X5:3 |
| 4 | X3: UPS output L1-L3 | 12 | X5:4 |
| 5 | X2, X3: neutral for UPS output and bypass input | 13 | X6:1 |
| 6 | External battery BATT+ and BATT- | 14 | X6:2 |
| 7 | PE | 15 | X6:3 |
| 8 | Neutral | 16 | X6:4 |

Top cable access kit

The following figure shows the top cable access kit for 30–150 kVA UPS units. The top cable access kit is optional. For more information, see Section [3.5.4](#). The part number of the cable access gland plate is P-157001278 (PLATE 93PM FLANGE D2 BLIND).

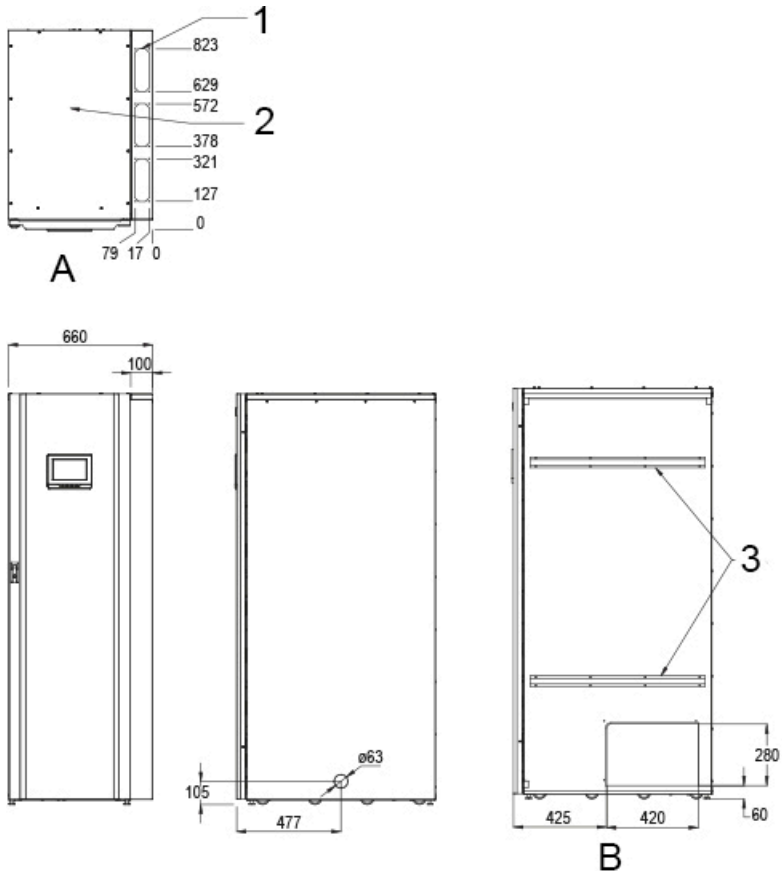

Figure 14. 93PM 30–150 kVA Top cable access kit

- | | | | |
|----------|-------------------------------------|----------|------------------------------|
| A | <i>View from the top</i> | 2 | <i>Top panel (removable)</i> |
| B | <i>View from the right</i> | 3 | <i>Cable binding profile</i> |
| 1 | <i>Top cable access gland plate</i> | | |

5.3 Installing 93PM 160-200kW with side integrated accessory cabinet MBS

Side integrated accessory cabinet for 160-200 kW 93PM includes a mechanical maintenance bypass switch and 1 or 2 input breakers depending on the model. The customer connections differ from the standard device. The minimum allowed prospective current to trip the breaker is 2500 A. For cable type recommendations, see Section [5.8](#).

These instructions guide the installation of the device with SIAC-MBS.

1. Remove the front plate of the integrated accessory cabinet (finger screw on the top of the plate).
2. Remove dead-front screws and dead-front.
3. Remove the applicable plates for cable installation access. You can install the power wiring through the rear, bottom or top of the cabinet. See Figures [18](#) and [19](#).
4. Drill or punch holes for the cable glands on the plate used for cable entry.
5. Install suitable cable glands on the plate.
6. Route all the cables through wire way to the UPS terminal block.
7. Reinstall wire entry plate and install conduit if needed.
8. Connect power wiring to the terminals and tighten to the right torque. See Table [14](#) and Figures [16](#) and [17](#).
9. When all wiring is complete, reinstall the safety shield panels. Make sure that the handle in the dead front is in the same position as the switch when reinstalled.
10. Install the front plate and tighten the finger screw on the top of the front plate.

Table 14: UPS power cable terminal torques (93PM 160-200 kW)

| Function | Tightening torque [Nm] | Bolt size |
|---------------|------------------------|-----------|
| L1, L2, L3, N | 80 | M12 |
| PE (ground) | 47 | M10 |

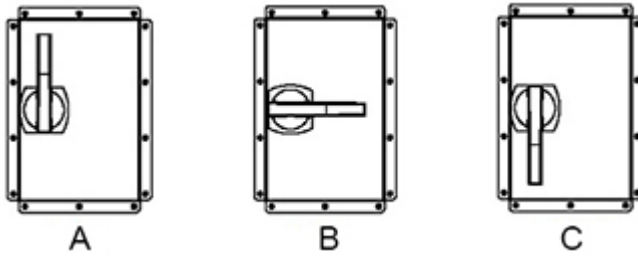

Figure 15. MBS positions

A UPS

C Bypass

B Test

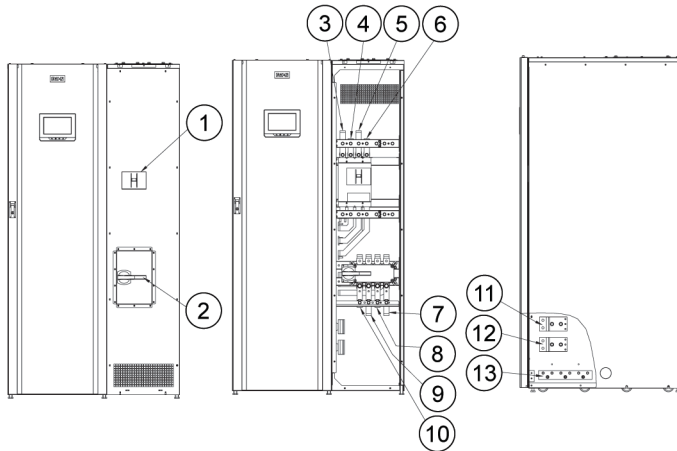

Figure 16. 93PM 200 kW SIAC-MBS connector locations (1 breaker single-feed version)

1 Bypass input breaker

8 X3: UPS output L3

2 Maintenance bypass switch

9 X3: UPS output L2

3 X2: Neutral for UPS input

10 X3: UPS output L1

4 X2: UPS input L3

11 External battery BATT+

5 X2: UPS input L2

12 External battery BATT-

6 X2: UPS input L1

13 Ground

7 X3: UPS output N

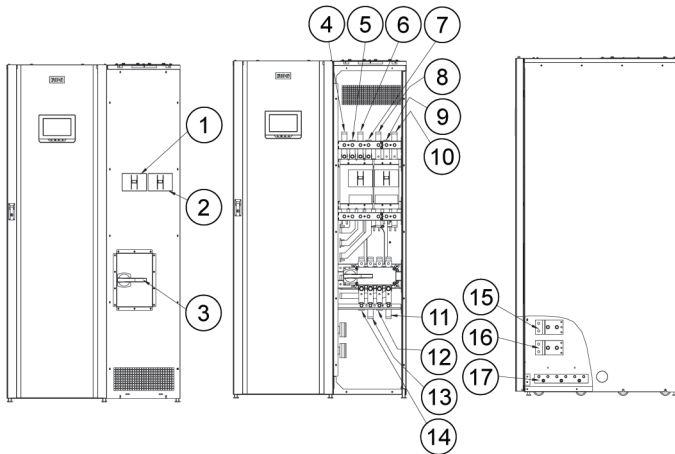

Figure 17. 200 kW SIAC-MBS connector locations (2 breaker dual-feed version)

- | | |
|--|-----------------------------------|
| 1 Bypass input breaker | 10 X3: Rectifier input L 1 |
| 2 Rectifier input breaker | 11 X3: UPS output N |
| 3 Maintenance bypass switch | 12 X3: UPS output L3 |
| 4 X1: Neutral & X2: Neutral for rectifier and bypass inputs | 13 X3: UPS output L2 |
| 5 X2: Bypass input L3 | 14 X3: UPS output L1 |
| 6 X2: Bypass input L2 | 15 External battery BATT+ |
| 7 X2: Bypass input L1 | 16 External battery BATT- |
| 8 X3: Rectifier input L3 | 17 Ground |
| 9 X3: Rectifier input L2 | |

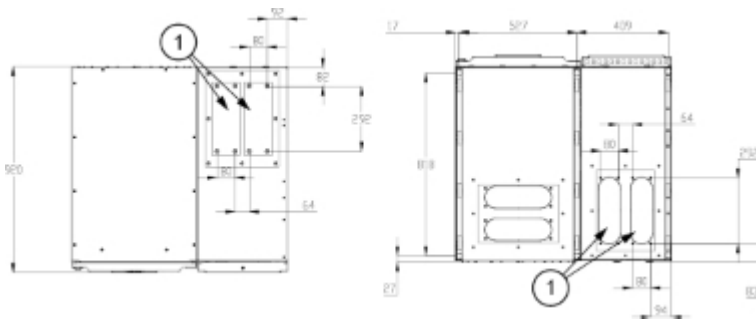

Figure 18. 93PM 200 kW SIAC-MBS gland plate locations (top and bottom)

- 1** Cable access gland plate

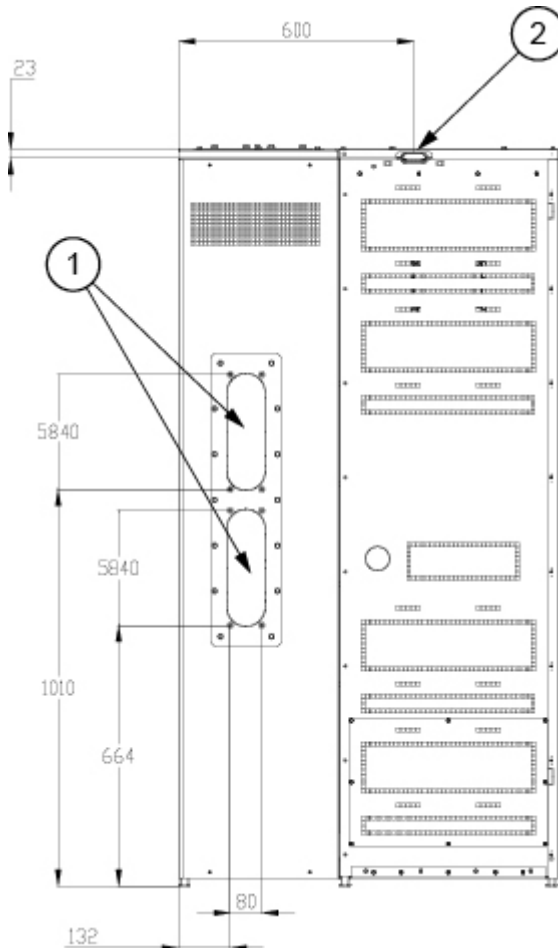

Figure 19. 93PM 200 kW SIAC-MBS gland plate locations (rear)

1 Cable access gland plate

2 Communication cable conduit

5.4 Installing the battery system

DANGER



This UPS can have internal batteries. The batteries are designed to deliver a large amount of energy. An incorrect connection can lead to a short circuit and cause serious injuries to the personnel or damages to the equipment. To

avoid damages to the equipment or injuries to personnel, let only the commissioning personnel do the connection of these batteries.



Note: See Section [9.5](#) for the battery specification.

WARNING



Do not connect battery strings with different battery quantity and voltage in parallel.

For Eaton 93PM product line, there are three different battery cabinets available: EBC-C, EBC-D and EBC-E. See a separate manual on instructions on how to install Eaton external battery cabinets.

If you are installing a customer-supplied battery system, install the battery system according to the battery and battery system manufacturer's instructions and all the applicable national codes and regulations. Only qualified personnel can install the battery system. Battery cables must be protected against current and thermal overload, that is, the battery system must include proper fuses or breaker with protection function. Ground the external battery cabinet to the UPS.

The default battery settings of the UPS are for 12 V VRLA batteries. If you need to use any other type of batteries, contact your Eaton representative.

30-100 kVA models enable wiring the battery power cabling via the side panels, if the UPS and the battery cabinet are installed side-by-side. See Figure [20](#).

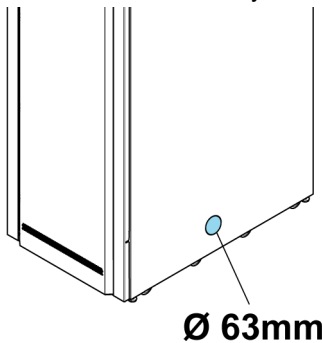

Figure 20. 30-100 kVA Side panel with battery power or battery signal wiring wireway



Note: Obey the installation instructions in Section [4.3.2](#).

5.4.1 Installing the battery system for 93PM UPS with separate battery option

If you choose to order a multi-modular Eaton 93PM UPS (up to 200 kVA) with a separate battery option, the UPS external battery connections require installing a separate battery for each UPM. Figure 21 and Figure 22 show the battery terminals in 93PM UPS with separate battery option.

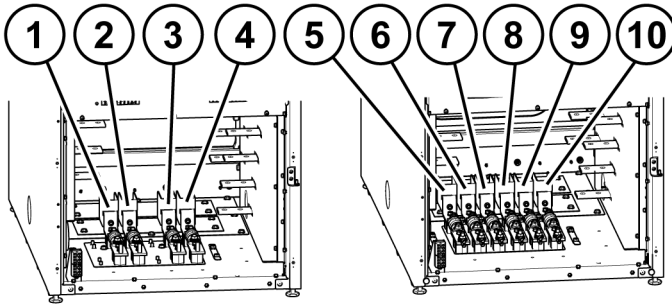

Figure 21. Separate battery option battery terminals for 93PM 100 kW and 150 kW, respectively

93PM 100 kW

- 1** Battery + for UPM 2
- 2** Battery + for UPM 1
- 3** Battery - for UPM 2
- 4** Battery - for UPM 1

93PM 150 kW

- 5** Battery + for UPM 3
- 6** Battery + for UPM 2
- 7** Battery + for UPM 1
- 8** Battery - for UPM 3
- 9** Battery - for UPM 2
- 10** Battery - for UPM 1

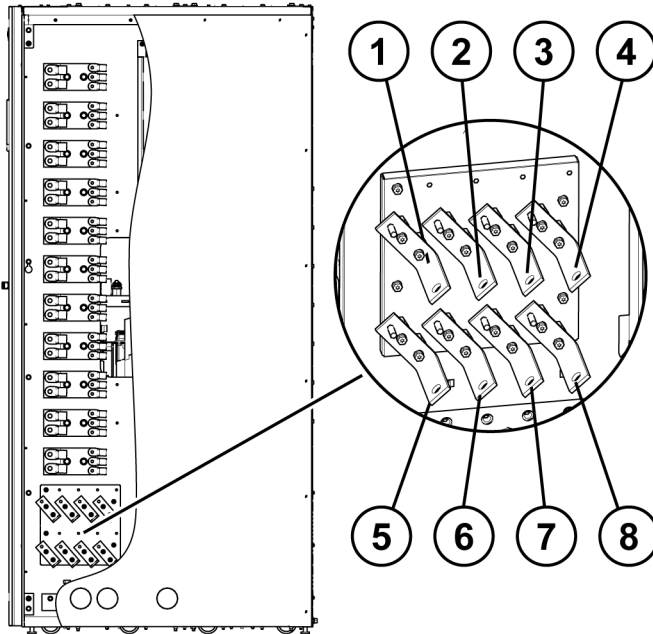

Figure 22. Separate battery option battery terminals for 93PM 200 kW

| | | | |
|---|---------------------|---|---------------------|
| 1 | Battery + for UPM 1 | 5 | Battery - for UPM 1 |
| 2 | Battery + for UPM 2 | 6 | Battery - for UPM 2 |
| 3 | Battery + for UPM 3 | 7 | Battery - for UPM 3 |
| 4 | Battery + for UPM 4 | 8 | Battery - for UPM 4 |

Table 15: Recommended battery cable and fuse sizes for separate battery

| | Separate battery per UPM |
|--|--------------------------|
| Battery cable, Pos. & Neg. line [mm ²] | 1 x 50 |
| Battery fuse [A] | 200 |

Table 16: Rated and maximum battery currents for rated power

| | Rated current [A] | Maximum current [A] |
|--------------------------|-------------------|---------------------|
| Separate battery per UPM | 122 | 146 |

5.4.2 Battery trip wiring

The 30-60 kVA UPS units are always equipped with an internal battery breaker. The 80–150 kVA units can be with or without an internal breaker. The 160-250

kVA units cannot have an internal breaker. The external battery breaker is a crucial part of the external battery cabinet or rack and must be placed in it.

Both internal and external battery breakers can be tripped (switched off) by energizing its shunt trip coil. The shunt trip coils are energized (controlled) through connectors X5 and X6. The status signal of the external battery breaker is connected to the Signal Inputs connector. There are five signal inputs and the user may utilize any one of them; the recommended input is number five. Status contacts of the Eaton battery breakers are open if the breaker itself is open. The default voltage of the shunt trip coil is 24 Vdc. For 48Vdc shunt trip, contact local Eaton Service Engineer.



Note: The default voltage of the battery breaker shunt trip coil is 24Vdc. For a 48Vdc shunt trip, contact an authorized Eaton Customer Service Engineer.

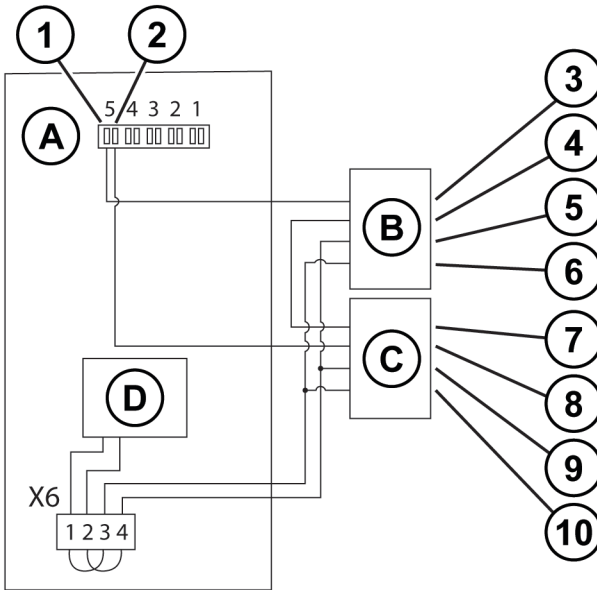

Figure 23. Battery trip wiring for 50 kW 93PM UPS

- | | | | |
|----------|--------------------------|-----------|--------------------|
| A | Signal inputs | 4 | Aux contact |
| B | External battery breaker | 5 | Shunt trip coil + |
| C | External battery breaker | 6 | Shunt trip coil - |
| D | Internal battery breaker | 7 | Aux contact return |
| 1 | Signal input 5 return | 8 | Aux contact |
| 2 | Signal input 5 | 9 | Shunt trip coil + |
| 3 | Aux contact return | 10 | Shunt trip coil - |

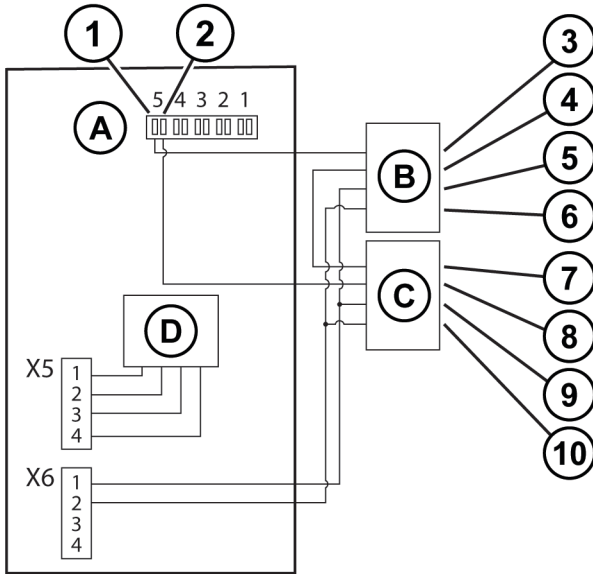

Figure 24. Battery trip wiring for 100–150 kW 93PM UPS

- | | | | |
|----------|--------------------------|-----------|--------------------|
| A | Signal inputs | 4 | Aux contact |
| B | External battery breaker | 5 | Shunt trip coil - |
| C | External battery breaker | 6 | Shunt trip coil + |
| D | Internal battery breaker | 7 | Aux contact return |
| 1 | Signal input 5 return | 8 | Aux contact |
| 2 | Signal input 5 | 9 | Shunt trip coil - |
| 3 | Aux contact return | 10 | Shunt trip coil + |

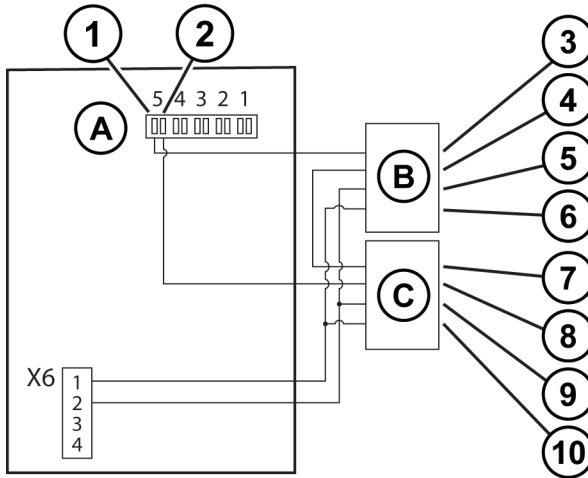

Figure 25. Battery trip wiring for 200 kW 93PM UPS

| | | | |
|----------|--------------------------|-----------|--------------------|
| A | Signal inputs | 5 | Shunt trip coil - |
| B | External battery breaker | 6 | Shunt trip coil + |
| C | External battery breaker | 7 | Aux contact return |
| 1 | Signal input 5 return | 8 | Aux contact |
| 2 | Signal input 5 | 9 | Shunt trip coil - |
| 3 | Aux contact return | 10 | Shunt trip coil + |
| 4 | Aux contact | | |

5.5 Installing a remote EPO switch

A remote EPO switch can be used in case of an emergency to shut down the UPS and remove power to the critical load from a location away from where the UPS is installed.

EPO is connected to the UPS's top front panel, on connector EPO. Figure 26 shows the NO and NC connections of the EPO switch.

EPO connector (front view):

- A = Normally open
- B = Normally closed

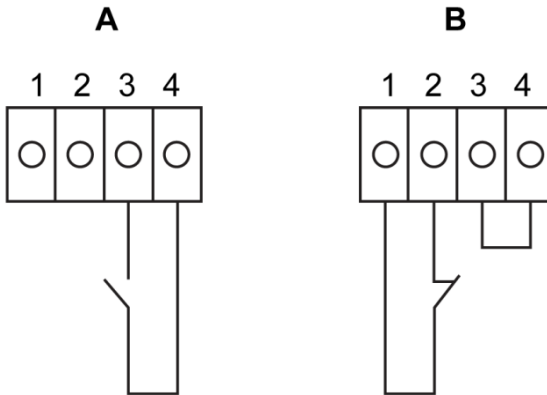

Figure 26. Connections of the EPO switch. Note that in "Normally closed" (B) situation a jumper between pins 3 and 4 is needed.

Table 17: Remote EPO wire terminations

| From remote EPO switch | To user interface terminal block EPO in UPS cabinet | Remarks |
|------------------------|---|--|
| NO | 3-4 | |
| NC | 1-2 | Wire jumper between 3-4 must be installed for proper functions |

5.6 Installing interface connections

93PM UPS contains a total of five (5) signal input connectors for customers which can be used for giving remote control commands to the UPS. Customer interface connector CN5 can be used for these purposes. Each input is a dry relay contact input and requires two wire signaling. None of the inputs are pre-programmed but need to be separately programmed by qualified service personnel.



Note: When using an external battery system, Eaton recommends you to connect external signal wiring.

There is also one general alarm relay output on the front panel. This output is either normally open (NO) or normally closed (NC). Polarity selection is made with wiring connection. By default, the general alarm relay activates when a system alarm is active, that is, any ALARM condition in the system is active. Alternatively, it can be activated with any particular event but this must be programmed separately by qualified service personnel. The alarm relay is designed for signal level (ELV or SELV) voltages only, not for utility use. For

higher signaling circuit voltage requirements, please use Industrial Relay Adapter in MiniSlot.

5.6.1 Installing customer input signals interface

These inputs are located behind the UPS door, in the top section of the UPS. See Figure 29 for the connector locations.

Tie points with strain relief for the communication cables are located on the right and left side of the cable conduit.

Signal inputs can be configured to different functions. Normally these functions are either informative (for example, “On Generator”) or functional (for example, a remote “Go to bypass” command).

5.6.2 Battery breaker wiring interface

When using the original accessory battery cabinet from the manufacturer, the battery breaker interface wiring is provided with the cabinet. The wiring is connected to the X5 and X6 terminal in the UPS.

When using a third-party battery system, the breaker must be equipped with auxiliary signal and should have a 24 V shunt trip for remote opening of the breaker, when needed.

See Section 5.4.2 for installation instructions.

5.6.3 Relay output interface connections

The general alarm relay is a dry relay signal output. The relay can be used for informing the operators about UPS alarm conditions, for example through a building management system. By default, the relay is configured to activate when the UPS general alarm is active, that is, any event when the *ALARM* status is active. The relay can also be configured to activate by some other event, but this needs to be done by authorized service personnel.

Relay signal wiring can be installed only through the signal cabling canal, from back to front, in the top section of the UPS.

Additional relay outputs are available with mini-slot cards. Relay outputs can be configured to be activated by various events. Configuration can be done by an authorized Eaton Customer Service Engineer or by other qualified service personnel authorized by Eaton.

5.6.4 Industrial Relay Card interface connections

Relays K1 through K5 are identical in function. Each output contact function can be assigned by the user. The UPS information may also be configurable.

To install the INDRELAY-MS:

1. Make sure that the ancillary equipment system is turned off and all the power sources are removed. Refer to the appropriate operation manual of any ancillary equipment for shutdown instructions.
2. Install wiring from the IRC to the monitoring equipment using appropriate conduits through the cable exit opening in the IRC.
3. Connect wiring between the IRC terminal blocks and the monitoring equipment using terminations. Connect one wire to COM (Common) and another to either NC or NO to select the Normally Open or Normally Closed option.
4. Install the INDRELAY-MS into an open MiniSlot communication bay in the UPS cabinet.

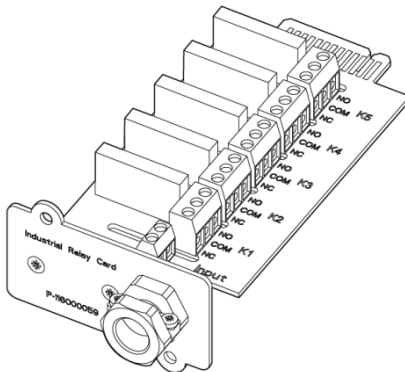

Figure 27. Industrial Relay Card INDRELAY-MS

5.6.5 MiniSlot interface connections

For MiniSlot accessories and communication devices selection, see Chapter 6. For installation and setup of a MiniSlot card, please contact your Eaton representative.

To install wiring to the connections:

1. If not already installed, install the LAN drops.
2. Open the front door of the UPS.
3. To remove the MiniSlot cover plate, remove the 2 screws securing the plate.
4. To install the MiniSlot communication device, push it all the way in.
5. Secure the MiniSlot communication device with 2 screws.
6. Route and install the LAN and other cables to the appropriate MiniSlot cards. The cable route is through the signal cable canal in the top section of the UPS.
7. For operator instructions, refer to the manual supplied with the MiniSlot card.

- When all the wiring is completed, close the front door and secure it with the latch.

5.6.6 Installing signal interface connections in a parallel system

The installation of the signal interface connections in a parallel system is done by following the aforementioned instructions. Signal inputs can be paralleled between the units, that is, the same contact can be used for several units' signal input signaling. This concerns also the EPO signal.

5.7 Wiring parallel 93PM UPS systems

The outputs of multiple 93PM UPS systems can be connected in parallel. Up to 8 units can be paralleled. The UPS static bypass power rating needs to be identical among all the paralleled units. However, paralleled UPS cabinets can be housed with different number of UPM power modules.

The outputs are paralleled to increase the load capacity of the power system and for redundancy. The system is paralleled for (N+1) redundancy, as long as there is always one or more UPS online than required to support the load. The system is paralleled for capacity if all UPSs in a system are required to support the load.

Communication between the UPSs is required for system metering and mode control. The system level communication and control are accomplished using a Controller Area Network (CAN). A pull-chain signal in each UPS, connected to the other UPSs in parallel and tied to the bypass status relay in each UPS, is used for a secondary communication path. This arrangement ensures bypass control even if the CAN bus is lost.

WARNING



Do not connect units equipped with an internal Maintenance Bypass Switch (MBS) or internal transformers in parallel.

5.7.1 Power wiring overview

See Section [4.3.2](#) for the recommended cable and external fuse sizes and installation practices.

Input feed

The input feed is defined as the power source connected to the UPS rectifier. The feed to all UPS's inputs must be derived from the same source.

Bypass feed

The bypass feed is defined as the power source connected to the UPS bypass. The feed to all UPS's bypass must be derived from the same source. The

shortest length of power wire from the source to the UPS must be a minimum of 95% of the length of the longest wire.

Output

The neutrals of all the UPSs must be connected. The shortest length of wire from the source to the UPS must be a minimum of 95% of the length of the longest wire. The measurement is with respect to where the UPS's outputs are tied.

Dual source

The input feed and bypass feed may be separate sources. The sources must share a common neutral.

Battery connection

A separate battery shall be connected to each UPS, and the battery capacity for each UPS must be identical. A common battery for all UPSs is not supported.

MOBs

Module Output Breakers (MOBs) allow the output of an UPS to be disconnected from other UPSs and the system load for maintenance and service. Design considerations assume that each UPS has a Module Output Breaker (MOB). The breaker should also disconnect the neutral for improved safety during maintenance.

The MOB must have a Form "C" auxiliary contact. The N.C contact is connected to the corresponding UPS's input used for signal input. The N.O. contact is used to disconnect the bypass pull-chain when the MOB is open. Figure 28 shows the principles of paralleled UPS systems including MOBs and outputs from UPSs.

MOB override

Users without MOBs installed can simply leave the MOB signal input disabled. The user should be aware that systems without MOB have limited maintenance capability.

Parallel system cabling

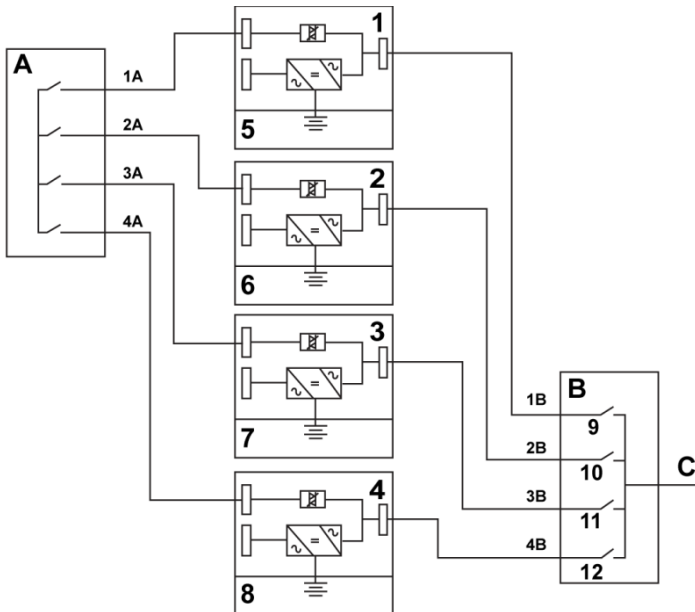

Figure 28. Principle of paralleled UPS systems

| | | | | | |
|---|-----------------------|---|---------|----|---------|
| A | Bypass inputs to UPSs | 1 | UPS 1 | 7 | Battery |
| B | Outputs from UPSs | 2 | UPS 2 | 8 | Battery |
| C | Load | 3 | UPS 3 | 9 | MOB1 |
| | | 4 | UPS 4 | 10 | MOB2 |
| | | 5 | Battery | 11 | MOB3 |
| | | 6 | Battery | 12 | MOB4 |

The required parallel system wiring length must be equal to ensure approximately equal current sharing when in the bypass mode.

For proper operation, the following must be true: $1A+1B=2A+2B=3A+3B=4A+4B$.

Any differences in wire length result in decreased capacity and improper operation of the UPS system while in the bypass mode.

5.7.2 Control signals overview

Two controls signals (External CAN Network, Bypass Pull-Chain) are required for external paralleling. Both of these control signals are fault-tolerant and alarmed when disconnected.

External CAN (ECAN)

ECAN provides a means for communication between the UPSs in a parallel system. The system will continue to share load and protect the load when this network fails

Bypass Pull-Chain

Bypass Pull-Chain is an open collector signal that goes low when the bypass static switch of any UPS is online. When External CAN (ECAN) is down, the pull-chain is low and the UPS is online, the UPS locks to and transfers to the bypass mode. Service personnel can manually short this signal in some rare failure modes to force the system transfer to bypass.

Signal Inputs Actions

Each UPS has maximum 8 signal inputs, 5 native and 1 in each MiniSlot when using a suitable connectivity device. These inputs can be configured with action items. The following action items affect all the UPSs in the system. When an action item is active on a UPS and the MOB is closed, the action item is transmitted on the ECAN to all the UPSs. All the UPSs react in the same manner as if the action item was active on that UPS.

Wiring the EPO switch in parallel

It is recommended to use separate EPO circuits for each parallel unit.

5.7.3 Installing bypass control wiring

- During the installation, follow all the safety instructions given in this document.
- A 12-pin terminal block for external parallel control signals is accessible on the right side of the communication interface, on the top section of the UPS (see Figure 5.7.3).
- The Phoenix Contact FRONT-MSTB 2,5/12-STF-5,08 plug component shall be used for cable wiring termination.

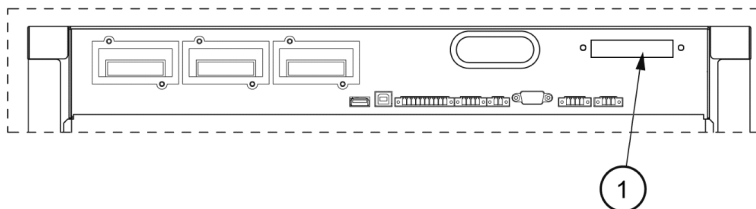

Figure 29. Communication interfaces

- 1 External parallel connector

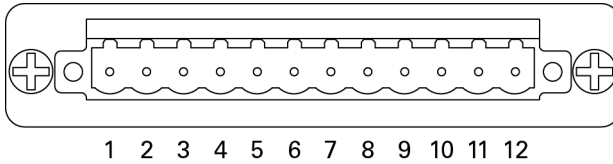

Figure 30. External parallel connector

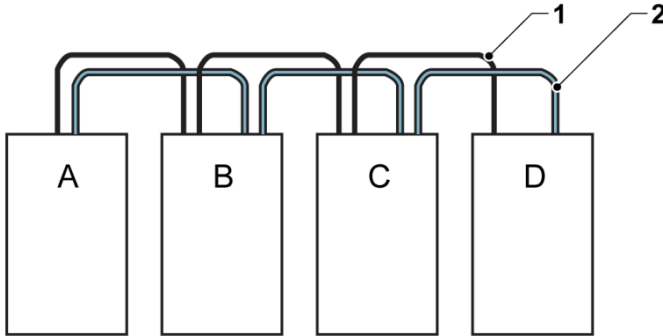

Figure 31. Simplified CAN and Pull-Chain wiring for parallel UPS system

- | | | | |
|---|----------------------|---|------------|
| A | UPS 1 | 1 | CAN |
| B | UPS 2 | 2 | Pull chain |
| C | UPS 3 (if installed) | | |
| D | UPS 4 (if installed) | | |



Note: This drawing is for distributed bypass wiring purposes and it is not a floor layout plan. UPSs can be placed in any physical order.

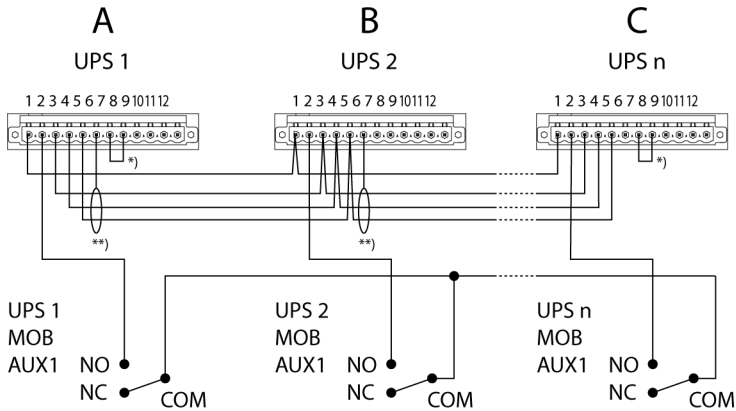

Figure 32. CAN and Pull-Chain wiring for parallel UPS with MOBs

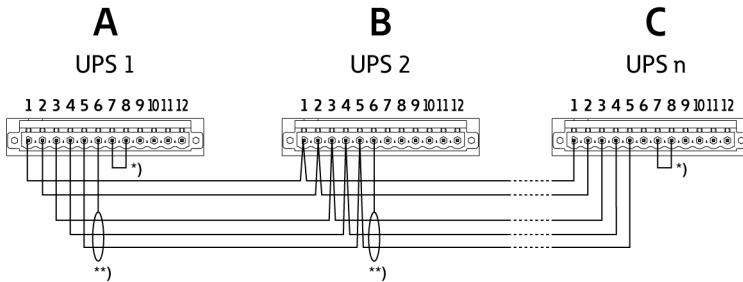

Figure 33. CAN and Pull-Chain wiring for parallel UPS without MOBs

- | | | | |
|----------|------------------------------------|-----------|---|
| A | External parallel connector, UPS 1 | 5 | GND (ISP) |
| B | External parallel connector, UPS 2 | 6 | Earth |
| C | External parallel connector, UPS 3 | 7 | CANBL |
| 1 | External pull chain | 8 | CANBH_1 |
| 2 | GND-S | * | Terminate the first and last UPS with a jumper. |
| 3 | CANBH | ** | Connect the shield from one end only. |
| 4 | CANBL | | |



Note: NC and NO designations on MOB AUX contacts are defined with the breaker in the OFF (open) position. If the MOB contacts have pigtail leads, use the same wire gauge to connect to the UPS and use the correct crimp connections for the wire gauge. External CAN connections between the UPS cabinets require shielded twisted pair wire. Use twisted pair wiring between

the UPS and MOB AUX contacts. Always confirm contact operation prior to wiring.

5.8 UPS system interface wiring preparation

Control wiring for features and options should be connected at the customer interface terminal blocks located on top front of the UPS, behind the door.



Note: Do not connect relay contacts directly to the mains-related circuits. Reinforced insulation to the mains is required.

Read and understand the following notes while planning and performing the installation:

- The customer must provide all interface wiring.
- When installing internal interface wiring to MiniSlot terminals, route the wiring through the internal opening in the MiniSlot communication bay.
- All signal inputs or remote features require an isolated normally open contact or switch (rated at 24 VDC, 20 mA minimum) connected between the alarm input and common terminal. All control wiring and relay and switch contacts are customer-supplied. Use twisted-pair wires for each alarm input and common.
- The signal inputs can be programmed to display the alarm functional name.
- LAN and telephone drops for use with MiniSlot cards must be provided by facility planners or the customer.
- The UPS Battery Aux and 24 VDC Shunt Trip signal wiring from the UPS must be connected to the DC source disconnect device. Also 48VDC Shunt Trip signal can be utilized via jumper changes for 80–200kW models without internal battery breaker. See Figure 24 and Figure 25.
- Battery Aux and 24 VDC Shunt Trip wiring should be a minimum of 1.5 mm².
- The Remote EPO feature opens all switchgear in the UPS cabinet and isolates power from your critical load. Local electrical codes may also require tripping upstream protective devices to the UPS.
- The Remote EPO switch must be a dedicated switch not tied to any other circuits.
- A jumper wire must be connected between pins 1 and 2 on connector EPO, if the normally-closed (NC) Remote EPO contact is used.
- Remote EPO wiring should be a minimum of 0.75 mm² and a maximum of 1.5 mm².
- The distance between the Remote EPO and the UPS cannot exceed 150 meters.
- Alarm relay contacts have a maximum current rating of 5 A and a switched voltage rating of 30 VAC (RMS) and 30 VDC.
- Alarm relay wiring should be a minimum of 0.75 mm².

6 Communication interfaces

This section describes the communication features of the Eaton 93PM UPS.

CAUTION



All the communication interfaces are SELV circuits. When connecting to other equipment, make sure that you maintain this characteristic.

The UPS has the following communication interfaces:

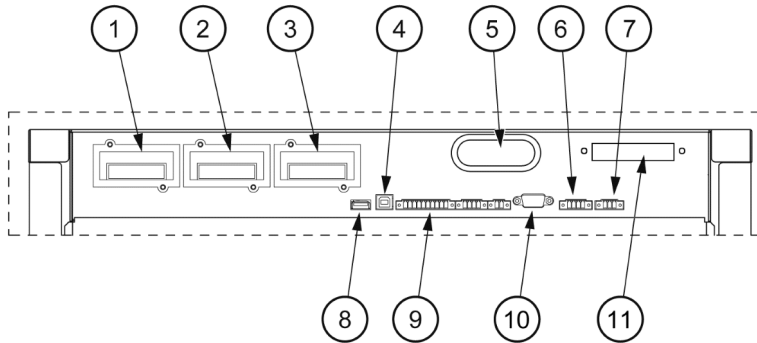

Figure 34. Communication interfaces

1. MiniSlot 1
2. MiniSlot 2
3. MiniSlot 3
4. USB device (connection to computer)
5. Communication cable conduit
6. Emergency Power Off (EPO)
7. Relay output
8. USB host (connection to accessories)
9. Signal inputs
10. RS-232 port for service
11. External parallel connector

6.1 MiniSlot cards

The Eaton 93PM UPS has three Mini-slot communication bays. For instructions on how to install a MiniSlot card, see [5.6.5](#).

The UPS is compatible with the following MiniSlot cards:

- Network Card-MS

Provides remote monitoring through a web browser interface, e-mail, and a network management system (NMS) using SNMP and connects to a twisted-pair Ethernet (10/100BaseT) network.

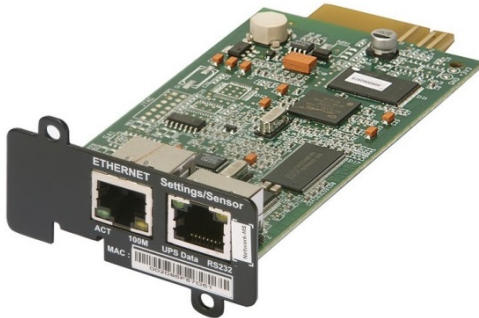

Figure 35. Network Card - MS

- PX Gateway Card

Provides remote monitoring through a Web browser interface, e-mail, and a network management system (NMS) using SNMP and connects to a twisted-pair Ethernet (10/100BaseT) network. The card also provides direct integration of UPS information (meters and status) to a Building Management System (BMS) using the Modbus RTU and TCP protocols as well as BACnet protocols.



Figure 36. PX Gateway Card

- Industrial Relay Card-MS

The MiniSlot Industrial Relay Card provides a way of connecting the UPS to industrial and electrical monitoring systems. It also enables a wide range of control applications by allowing up to 250 volts and 5 Amperes through its 5 relay connections. By connecting wires to the corresponding places in its terminal blocks, you can choose Normally Open or Normally Closed setup for each output.

For information on how to configure Industrial Relay Card-MS, see Section [6.5](#).

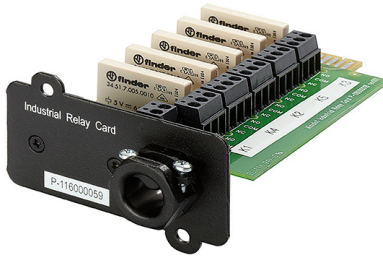

Figure 37. Industrial Relay Card-MS

6.2 Intelligent Power Software

Intelligent Power Software are productivity tools for UPS power management. These software solutions enhance the protection provided by a UPS by shutting down applications and operating systems, triggering disaster recovery procedures and migrating virtual machines in case of an extended power outage. They also help in reducing downtime and increasing the reliability of the UPS by alarming the operators of issues and monitoring vital meters. The software can also be used to view the usage characteristics of power equipment across the enterprise and use the data to optimize the use of the facilities.

Intelligent Power Software is web-based, which means that the information can be accessed through any device that has a web browser.

On one hand, Intelligent Power Manager (IPM) is a monitoring system that can concentrate the data and alarms of hundreds of UPS, ePDU and other devices into a single view. On the other hand, it provides a link to virtualization through management systems, such as VMware vCenter. This way an administrator gets a single pane of glass to manage both IT equipment and the supporting infrastructure. IPM provides the shutdown, migration, disaster recovery and load shedding features in virtualized environments.

Intelligent Power Protector (IPP) is a shutdown agent with basic monitoring and alarming capability. It provides automatic, graceful shutdown of computers and virtual machines or servers powered by an Eaton UPS during a power outage that lasts longer than your available battery runtime. Intelligent Power Protector can be remotely supervised and managed by the Intelligent Power Manager (IPM) application.

Intelligent Power Software is delivered on a CD with the UPS. Alternatively, you can download it from the Eaton web page. Some of the advanced features of IPM require a license, contact your Eaton representative for details.

6.3 Signal input monitoring

This standard feature lets you connect smoke detectors or over-temperature alarms to your signal inputs. The user interface terminals for external connections are located inside the UPS. Use twisted-pair wires for each alarm input and common.

The signal inputs can be programmed to display the alarm functional name. See list of Signal input functions in Appendix A: Relay alarms.

6.4 General purpose relay contact

One general purpose relay contact is provided as a standard feature on the UPS. An alarm contact is also provided.

You can use a normally-closed or normally-open contact. If the state of the contact changes from the state you specify as normal, a signal is issued. You can connect this contact to equipment at your facility (such as a light or an alarm bell) to let you know when an alarm is active on the UPS. This feature is useful if the UPS is located in a remote area where the UPS horn may not be heard immediately.



Note: Do not operate the contacts in excess of 30 VAC (RMS) and 30 VDC at 5 A maximum.

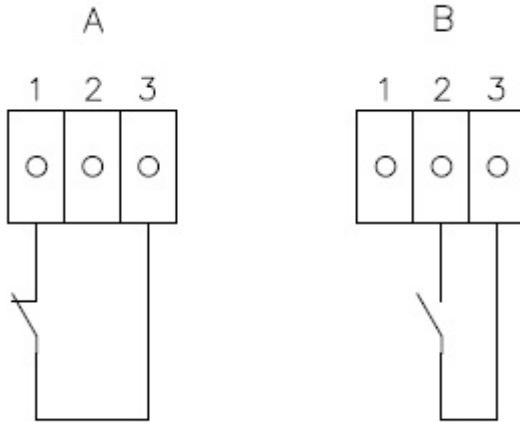

Figure 38. Output relay configurations: A) Normally closed (pins 1 and 3), B) Normally open (pins 2 and 3)

6.5 Configuring relays

93PM offers one native relay output. Additionally, each of the 3 MiniSlots can be equipped with a 5-relay adapter for additional relay outputs. These instructions guide you through the relay configuration.

The relay configuration can be done via the display. See Appendix A: Relay alarms for available nodes that can be configured to relays.

The maximum voltage of the relay is 30 V. Examine the voltage and current specifications of the other cards from the previous sections.

The process for relay configuration:

1. In the home screen of the display, click the lock icon in the top right corner to type in the service password.
2. In the sign in window, click the password field containing the 4 dots.



Figure 39. Sign in window with the password field

3. Enter the password 0101 and press .
4. Select **Continue**.
5. Select **Configuration** and then **Relays Outputs**.

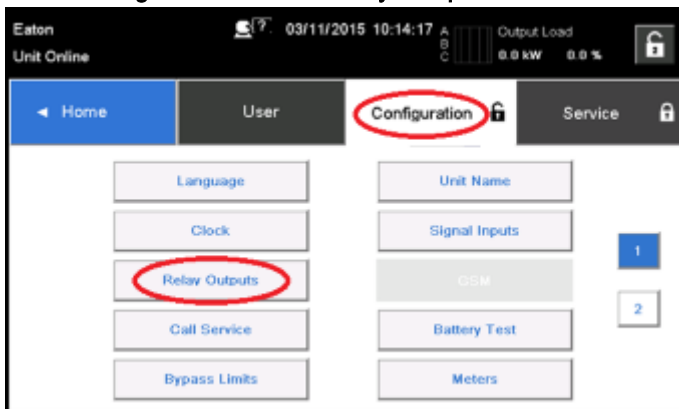

Figure 40. Selecting Relay Outputs in the Configurations screen

6. Select from these options:
 - Native (Alarm) relay
It is possible to set 8 different events for the native relay. If any of the set events occurs, the relay is activated
 - MiniSlot 1
 - MiniSlot 2
 - MiniSlot 3



Figure 41. Options for relay outputs configuration

7. Enter the code(s) of the function(s) that you want to trigger the relay when they become active.
8. Press **OK** and **Save** to save the changes.

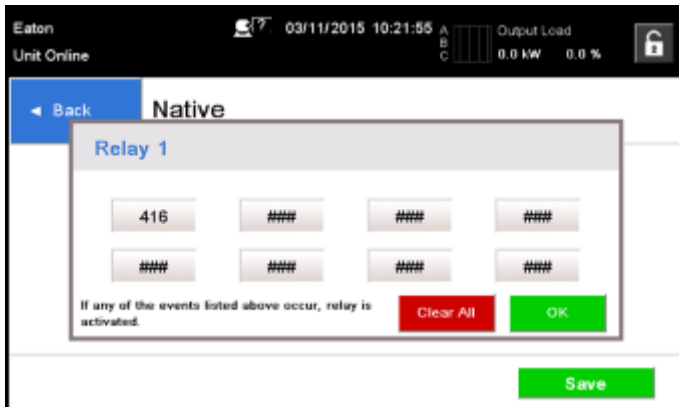

Figure 42. Entering the codes of the functions that will trigger the relay

9. If you selected one of the MiniSlots, these default values are available:
 - Relay 1: #262 On Line (LED is lit)
 - Relay 2: #260 On Battery (LED is lit)
 - Relay 3: #352 Alarm (LED is lit)
 - Relay 4: #261 On Bypass (LED is lit)
 - Relay 5: #15 Low Battery warning

Alternatively, you can configure the relays with any event you want.

10. You can test the relays by selecting any of the options in the test mode (see Figure 41).

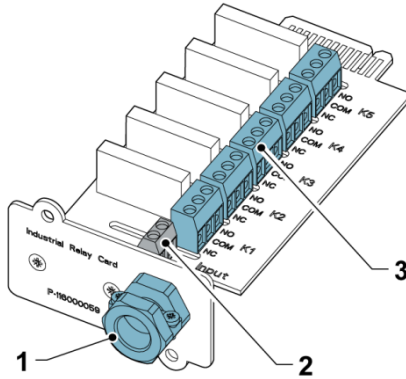

Figure 43. Relays

- | | |
|--|---|
| <p>1 Cable exit opening for up to 12 mm ($\frac{1}{2}$" conduit</p> <p>2 Signal input connector with voltage supply</p> | <p>3 K1 thru K5 terminal connections for relay contacts to operator's monitoring equipment</p> |
|--|---|

7 UPS operating instructions

This section describes how to operate the UPS.



CAUTION

Before you operate the UPS, make sure that all the installation tasks are completed and a preliminary startup has been performed by authorized service personnel. The preliminary startup verifies all the electrical interconnections to make sure that the installation was successful and the system operates properly.

Before you operate any of the controls, read these instructions and have a thorough understanding of the UPS operation.

The UPS is configured to operate with one of the following nominal voltages: 380, 400, or 415 VAC. Before you start to operate the UPS, confirm the UPS nominal voltage and frequency from the display by selecting **Settings > Information**. If the UPS need to be operated with another voltage or frequency, contact your closest Eaton office or Eaton authorized partner.



Note: The UPS is not a measuring device. All the displayed measurements are approximate values only.

7.1 UPS controls and indicators

7.1.1 Control panel

The control panel, located on the UPS front door under a protective hatch door, contains a color touch screen display. It is used to display the status of the UPS system and control the operation of the UPS.

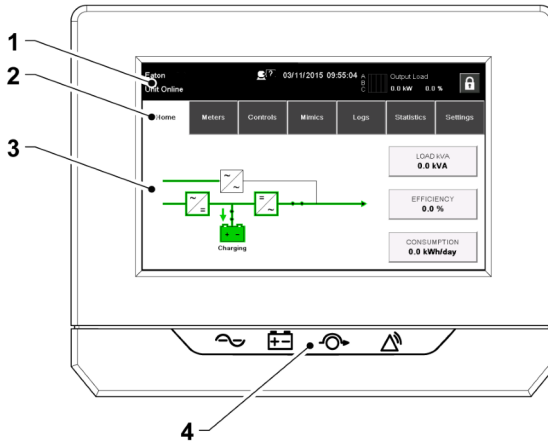

Figure 44. Parts of the display



The display consists of the following parts:



| | | |
|---|-------------------|---|
| 1 | Status bar | The status bar displays the UPS name, state, current date and time, meters information, and a sign in/out button. It also shows any active alarms and warnings. |
| 2 | Main navigation | Select a screen by tapping on its name. |
| 3 | Content area | This is the main area for showing information on the UPS status and operations. |
| 4 | Status indicators | See Section 7.1.2 . |

7.1.2 Status indicators

The four symbols below the display are status indicators. They are colored light emitting diode (LED) lamps, and they work in conjunction with the alarm horn to let you know the operating status of the UPS.

Table 18: Status indicators

| Indicator | Status | Description |
|--|--------|---|
| Green symbol for normal operation  | On | The UPS is operating normally and supplying power to the critical load. |
| | Off | The UPS is turned off. |
| Yellow symbol for battery mode  | On | The UPS is in the battery mode. Because the battery mode is a normal condition of the UPS, the green indicator for normal operation also remains illuminated. |

| Indicator | Status | Description |
|--|--------|---|
| Yellow symbol for bypass mode  | On | The UPS is in the bypass mode. The critical load is supported by the bypass source. The green indicator for normal operation is not illuminated when the system is in the bypass mode. |
| Red symbol for active alarm  | On | The UPS has an active alarm and requires immediate attention. The screen shows the highest priority active alarms. All alarms are accompanied by an audible horn. To silence the horn, press any control panel button once. The alarm indicator may be illuminated along with other indicators. |

Color LED indicators

The LED indicators consists of two rows of LEDs located on the left and right sides of the UPS cabinet door. The LEDs are red, green and yellow (RGY). The color of the LED is used to indicate the condition of the UPS. The most urgent condition is always the one shown. Only one color is shown at a time. The table below defines which color is shown.

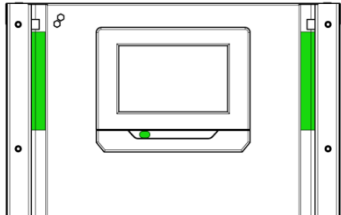
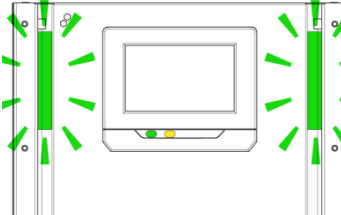
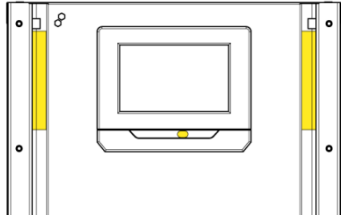
| Color LED indicators (screen and door) | UPS status |
|---|---|
|  | Normal operation |
|  | Battery mode The green LEDs on the sides of the UPS cabinet door are blinking and the yellow symbol for battery mode is illuminated below the display. Since the battery mode is a normal condition of the UPS, the green symbol for normal operation is also illuminated below the display. |
|  | Bypass mode |

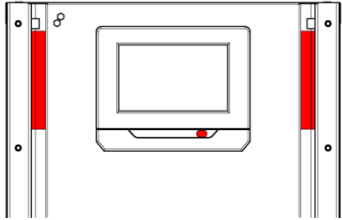
| Color LED indicators (screen and door) | UPS status |
|---|------------|
|  <p>The diagram shows a central rectangular display screen. On either side of the screen are vertical strips representing the control panel and door. Each strip contains two red vertical bars, indicating that the LEDs are illuminated. There are also small circles representing buttons or sensors on the strips.</p> | Alarm |

7.1.3 System events

When the UPS system is running in the double conversion mode, it continually monitors itself and the incoming utility power. In the battery or bypass mode, the UPS may issue alarms to let you know exactly what event caused the change from the double conversion mode. System events on the UPS can be indicated by horns, lights, messages, or all three.

Select **Logs** in the home screen to look at any currently active events.

- **System event horn**
The system event horn beeps to alert the user that an event requiring attention is taking place.
- **System event indicators**
The status indicators on the UPS control panel and the event horn let you know when the UPS system is operating in any mode other than the double conversion mode. Only the green indicator for normal operation is visible during normal UPS system operation. The other indicators illuminate to indicate alarms or events. When an alarm occurs, do a check on these indicators to see what type of event has taken place.
- **System event messages**
When a system event occurs, a message appears in the status bar of the display. This message is also written to the Active Events log. Some notices and alarms may be accompanied by an audible horn. To silence the horn, press any button once.

7.1.4 Menu structure of the 93PM UPS

The following table shows the menu structure of the 93PM UPS.

Table 19: Menu structure of the 93PM UPS

| Main menu | Submenu | Functions |
|-------------|---------|--|
| Home | - | An overview of the UPS operation, including information on load, efficiency and consumption. |

| Main menu | Submenu | Functions |
|---------------|----------------|---|
| Meters | Meters summary | A summary of the UPS or system meters. |
| | Input meters | Detailed information on UPS or system input meters. |
| | Bypass meters | Detailed information on UPS or system bypass meters. |
| | Output meters | Detailed information on UPS or system output meters. UPM Power |
| | Battery meters | Detailed information on UPS or system battery meters. |

| Main menu | Submenu | Functions |
|-----------------|-----------------|---|
| Controls | System controls | Go Online Go to bypass Turn Off Charger Load Off |
| | UPS controls | Run battery test Shut down UP |
| | Module controls | Start charger Run battery test Shut down module / Start module UPM 1: <ul style="list-style-type: none"> • Charger • Battery test • UPM status UPM 2: <ul style="list-style-type: none"> • Charger • Battery test • UPM status |
| | EAA controls | ESS: <ul style="list-style-type: none"> • Enable • Disable • Configure VMMS: <ul style="list-style-type: none"> • Enable • Disable • Configure Enable High Alert Clear status ABM: <ul style="list-style-type: none"> • Enable • Disable • Configure Clear Alarms Clear Logs |

| Main menu | Submenu | Functions |
|-------------------------------------|----------------------------|---|
| Mimics | UPS mimics | An overview of the UPS operation, including information on load, efficiency and consumption. If there is an error, an error indicator is displayed next to the affected part. Active events log can be opened by tapping the error indicator. |
| | UPS module map | Module map shows the status of each UPM. |
| | System overview | System overview shows the status and meters summary for each UPS. |
| | ESS | The ESS mimic screen shows the approximated consumption and energy savings of the ESS mode. |
| Logs | Active events | All active events are displayed. |
| | System log | A log of all system events. |
| | Service log | A detailed log of UPS operations. |
| | Change log | A log of all changed settings and their values. |
| Statistics: UPS, Battery | Statistics summary | A summary of UPS statistics |
| | Statistics details | Details are available by pressing on different statistics. |
| Settings | User Configuration Service | Configurable user settings. For details, see Section 7.1.4.1 . |

7.1.4.1 User settings

The UPS has the following settings that are user-modifiable. In the Home screen, select **Settings**.

Table 20: User settings

| Setting | Description |
|--------------------|--|
| Information | Information on the UPS model, including part number and serial number. |
| About | Version information. |

To modify the **Configuration** settings, you need to sign in.

Table 21: Configuration settings

| Setting | Description |
|---------------------|--|
| Language | Change the user interface language. |
| Unit Name | Change the unit name. |
| Clock | Change the date and time, change the clock format or enable/disable NTP clock setup. |
| GSM | GSM modem. |
| Call Service | Send automatic e-mail to the service center in case of a failure. |

| Setting | Description |
|------------------------------|--|
| Signal Input | Select signal input name and function or change contact polarity. |
| Relay Outputs | Configure the relay outputs. |
| Battery test | Change the power level and duration for battery test. |
| Bypass Limits | Change the bypass voltage or bypass frequency. |
| Screen Saver Time-out | Change the screen saver timeout. |
| Meters | Change the meters format. |
| Lamp Test | Enable the lamp test. |
| HMI backlight | Adjust the backlight brightness. |
| Control P/W level 1 | Change the level 1 password, or remove the password on level 1. The default value is 1111. |
| Control P/W level 2 | Change the level 2 password. The default value is 1010. |
| Reset statistics | Reset all statistics. |
| Minimum required kVa | Change the minimum required kVa. |

7.2 Signing in

If the level 1 password is enabled, you need to sign in.

1. Press the lock icon in the top right corner of the screen.
2. Type in your password and press **OK**.
You are signed in.
3. Press **Continue** to return to the previous screen.

You have 3 attempts to type in the password. If an incorrect password is given more than 3 times, you need to wait for 30 minutes before trying again.

Table 22: Default passwords

| Level | Name | Password | Description |
|-------|---------------|--------------|--|
| 0 | USER | NONE | USER |
| 1 | CONTROL | 1111 | USER + CONTROL |
| 2 | CONFIGURATION | 0101 | USER + CONTROL + CONFIGURATION |
| 3 | SERVICE | Service Only | USER + CONTROL + CONFIGURATION + SERVICE |

To modify the user settings, you need to enter the level 2 password.

7.3 System control instructions

7.3.1 Starting the UPS system in the double conversion mode

The UPS system can consist of a single UPS or several parallel UPSs. UPSs with their MOB open are not considered as part of the system.

To start the UPS system:

1. Open the UPS front door.
2. If included inside the UPS system, check that the rectifier input switches are closed.
3. Check that the battery breaker is closed.
4. Close the UPS front door.
5. Close the UPS input feeder circuit breaker.
6. Close the UPS bypass input feeder circuit breaker.
7. Wait for the UPS control panel display to become active and to indicate logic power.
8. Repeat steps 1-7 for each individual UPS in the system.
9. In the home screen, press **Controls**.
The System controls screen appears.
10. In the System controls screen, make sure that the system status is **SHUTDOWN**.
11. In the System controls screen, press the **Go online** button.
If Auto Bypass is enabled (factory default), the critical load is immediately supplied by the bypass source, in the bypass mode, until the inverter turns on and the UPS transfers to the double conversion mode. The status indicator on the UPS control panel indicates that the UPS is in the bypass mode. If auto bypass is not enabled, the UPS output remains off until the UPS system transfers to double conversion mode.
12. Wait for these messages to appear sequentially on the System controls screen:
STARTING
ONLINE
The rectifier and inverter turn on. The DC voltage continues to ramp up to full voltage. Once the DC link reaches full voltage and the battery breaker is closed, the UPS output relay K3 closes and the static switch turns off. Power is now supplied to the critical load in the double conversion mode. It takes approximately 20 seconds for the UPS system to achieve the double conversion mode.

The UPS system is now operating in the double conversion mode. The green status indicator for normal operation is illuminated in all the UPSs in the system.

7.3.2 Starting the UPS system in the bypass mode

CAUTION



In the bypass mode, the critical load is not protected from mains power interruptions and abnormalities.

If the inverter output of the UPS is not available and the critical load needs to be energized, perform the following procedure:

1. Open the UPS front door.
2. If included inside the UPS system, check that the rectifier input switches are closed.
3. Make sure that the battery breaker is closed.
4. Close the front door.
5. Close the UPS input feeder circuit breaker.
6. Close the UPS bypass input feeder circuit breaker.
7. Wait for the UPS control panel to become active and indicate logic power.
8. Repeat steps 1-7 for each single UPS in the system.
9. In the home screen, press **Controls**.
The System controls screen appears.
10. In the System Controls screen, make sure that the system status is shown as **SHUTDOWN**.
11. In the System controls screen, press the **Go to bypass** button.
The critical load is immediately supplied by the bypass source, in the bypass mode.

The UPS system is now operating in the bypass mode. The yellow bypass status indicator is illuminated.

7.3.3 Transferring from the double conversion mode to the bypass mode

CAUTION



In the bypass mode, the critical load is not protected from mains power interruptions and abnormalities.

To transfer the critical load to the bypass mode, perform the following procedure:

1. In the home screen, press **Controls**.
The System controls screen appears.
2. In the System controls screen, press the **Go to bypass** button.
The UPS system transfers to the bypass mode and the critical load is immediately supplied by the bypass source. If the bypass source is not available, the power processor remains on and an alarm sounds.

The UPS system is now operating in the bypass mode and the yellow bypass status indicator is illuminated. The UPM status is shown as **Ready**. The system status is shown as **ON BYPASS**.

7.3.4 Transferring from the bypass mode to the double conversion mode

To transfer the critical load to the double conversion mode, perform the following procedure:

1. In the home screen, press **Controls**.
The System controls screen appears.
2. In the System controls screen, press the **Go online** button.
The UPS system transfers to the double conversion mode. If there is not enough UPM capacity available, the system remains in the bypass mode and an alarm sounds.

The UPS is now operating in the double conversion mode. The green status indicator for normal operation is illuminated. The system status is shown as **UNIT ONLINE**.

7.3.5 Transferring from the double conversion mode to the Energy Saver System mode



Note: Note that the Energy Saver System mode commands are displayed only if enabled at the factory or by an authorized Eaton Customer Service Engineer .

To transfer the critical load to the Energy Saver System mode:

1. In the home screen, press **Controls**.
2. Select **Service controls**.
3. Select **Enable ESS**.
The entire UPS system transfers to the Energy Saver System mode and the critical load is supplied by the bypass source. If the bypass source is not available or the conditions are not correct for the ESS mode, the power module remains on and an alarm sounds. The green status indicator for normal operation is illuminated. The UPS status is shown as **UNIT ONLINE , ESS**. The UPM status is shown as **READY**.

7.3.6 Transferring from the Energy Saver System mode to the double conversion mode



Note: Note that the Energy Saver System mode commands are displayed only if enabled at the factory or by an authorized Eaton Customer Service Engineer.

To transfer the critical load to the double conversion mode:

1. In the home screen, press **Controls**.
2. Select **Service controls**.
3. Select **Disable ESS**.
The UPS system transfers to the battery mode and then to the double conversion mode. If the power module is not available, the system remains in the bypass mode and an alarm sounds. The green status indicator for normal operation is illuminated. The UPS status is shown as **UNIT ONLINE**. The UPM status is shown as **ACTIVE**.

7.3.7 Shutting down the UPS system and critical load

To perform maintenance or service on the critical load, shut down the power to the load by performing the following procedure:

1. Turn off all the equipment that is powered by the UPS system.
2. Perform the LOAD OFF procedure (see Section [7.3.8](#)).
The input, output, and bypass backfeed contactors open, the battery breaker or disconnect is tripped, and the power module is turned off.
3. Open the UPS front door.
4. If included in the UPS system, open the rectifier input switches.
5. Check that the battery breaker is open.
6. Close the UPS front door.
7. Open the UPS input and bypass feeder circuit breakers.
8. Repeat steps 3–7 for all the UPSs in the system.



DANGER

Power is still present inside each UPS cabinet until the upstream feeder circuit breaker is opened, and in case of a parallel system, the output is isolated or parallel units are shut down as well.

7.3.8 De-energizing the critical load

Initiate a UPS system Load Off by pressing the **Load Off** button in the **Controls > System Controls** screen. This button can be pressed to control the UPS output. The **Load Off** button de-energizes the critical load and shuts down the UPS system. The UPS system (including bypass) remains off until it is restarted.

1. Press **Load Off**.
The shutdown screen appears, providing a choice to proceed or abort the shutdown.
2. To shut down the UPS, press **Load Off**. To abort the shutdown, press **Abort**.



Note: All power to the critical load is lost when Load Off is selected. Only use this feature when you want to de-energize the critical load.

When **Load Off** is selected, the input, output, and bypass backfeed contactors open, the battery breaker or disconnect is tripped, and all the UPSs in the system are turned off.

To restart the UPS system, follow the procedure in Section [7.3.1](#) or Section [7.3.2](#).

CAUTION



Do not attempt to restart the system after Load Off until you have identified and cleared the cause of the shutdown.

7.4 UPS control instructions

7.4.1 Starting a single UPS

Make sure that the load level does not exceed the single UPS capacity.

To start the UPS:

1. Open the UPS front door.
2. If included inside the UPS system, check that the rectifier input switches are closed.
3. Check that the battery breaker is closed.
4. Close the UPS front door.
5. Close the UPS input feeder circuit breaker.
6. Close the UPS bypass input feeder circuit breaker.
7. Wait for the UPS control panel display to become active and indicate logic power.
8. In the home screen, press **Controls**.
9. Press the **UPS controls** button.
In the UPS controls screen, the system status is shown as **SHUTDOWN**.
10. In the UPS controls screen, press the **Go online** button.
If Auto Bypass is enabled (factory default), the critical load is immediately supplied by the bypass source in the bypass mode, until the inverter turns on and the UPS transfers to the double conversion mode. The yellow status indicator on the UPS control panel indicates that the UPS is in the bypass mode. If auto bypass is not enabled, the UPS output remains off until the UPS system transfers to the double conversion mode.
11. In the UPS control screen, press the **Go online** button.
12. Wait for the following messages to appear sequentially on the UPS status line:

STARTING

ONLINE

The rectifier and inverter turn on. The DC voltage continues to ramp up to full voltage. Once the DC link reaches full voltage and the battery breaker is closed, the UPS output relay K3 closes. Power is now supplied to the critical load in the double conversion mode. It takes approximately 20 seconds for the UPS system to achieve the double conversion mode.

The UPS system is now operating in the double conversion mode and the green status indicator for normal operation is illuminated.

7.4.2 Shutting down a single UPS

A single UPS in the system can be shut down only if it is redundant. In practice, this means that a UPS is not allowed to be shut down if doing so would lead to an overload condition in the remaining UPSs in the system.

To shut down a single UPS:

1. In the home screen, press **Controls**.
The System controls screen is displayed.
2. In the System controls screen, press **UPS controls**.
3. In the UPS control screen, select **Shut down UPS**.

7.4.3 Enabling and disabling the battery charger

To turn the battery charger on or off, perform the following procedure:

1. In the home screen, press **Controls**.
The System controls screen appears.
2. In the System controls screen, press **UPS controls**.
3. Press the **Turn on / Turn off** button.

7.5 UPM control instructions

7.5.1 Starting the UPMs

Make sure that the load level does not exceed the single UPM capacity.

To start an individual power module in the double conversion mode:

1. Open the UPS front door.
2. If included inside the UPS system, check that the rectifier input switches are closed.
3. Check that the battery breaker is closed.
4. Close the UPS front door.
5. Close the UPS input feeder circuit breaker.
6. Close the UPS bypass input feeder circuit breaker.

7. Wait for the UPS control panel to become active and indicate logic power.
8. In the home screen, press **Controls**.
The System controls screen is displayed.
9. In the System controls screen, check that the UPS status is shown as **SHUTDOWN**.
10. Check that there are no active alarms.
11. In the System controls screen, press **Module controls**.
The Select module screen is displayed.
12. Select the UPM you want to start.
The UPM control screen is displayed. The UPM status is shown as **SHUTDOWN**.
13. In the UPM control screen, select **Start module**.
14. Wait for the following messages to appear sequentially on the UPM status line:
READY
ACTIVE
The UPM rectifier and inverter turn on and the UPM transfers to the double conversion mode and supplies the critical load.

7.5.2 Shutting down the UPMs

A single UPM in the system can be shut down only if it is redundant. In practice, this means that a UPM is not allowed to be shut down if doing so would lead to an overload condition in the remaining UPMs or UPSs in the system.

To shut down a single UPM:

1. In the home screen, press **Controls**.
The System controls screen is displayed.
2. In the System controls screen, press **Module controls**.
The Select module screen is displayed.
3. Select the UPM you want to shut down.
4. In the UPM control screen, select **Shut down module**.

7.6 Using the Remote Emergency Power-off switch

A UPS emergency power-off is initiated by the EPO pushbutton switch. In case of an emergency, you can use this switch to control the UPS output. The EPO switch de-energizes the critical load and powers down the UPS immediately without asking for verification. The UPS, including the static bypass switch, remains off until it is restarted.

CAUTION

When the EPO switch is activated, all power to the critical load is lost. Use this feature only in case of emergency.



Note: The following instructions are for the EPO switch supplied by Eaton Corporation. If you are using a customer-supplied EPO switch, it may not activate in the same way. For operating instructions, see the documentation provided with the switch.

To use the EPO switch:

1. Press the EPO pushbutton switch.
The input, output, and bypass backfeed relays open, the battery breaker or disconnect is tripped, and the power module is turned off immediately, without asking for verification.

To restart the UPS after using the EPO pushbutton, reset the EPO switch and then follow the procedure in Section 7.3.1 or Section 7.3.2.

WARNING

Do not attempt to restart the system after using the EPO switch until the conditions for safe start-up have been confirmed.

7.7 Turning the UPS from the double conversion mode to the maintenance bypass mode

Only trained personnel who are familiar with the behavior and functions of the UPS are allowed to operate the internal MBS. A full UPS wiring diagram with MBS switch is presented in the schematic diagram.



Note: The internal MBS and static bypass must be supplied by the same source.

The MBS has 3 positions: UPS, Test and Bypass. When the MBS is turned to the Test position, the UPS is already turned to maintenance bypass and it no longer provides protected input to the load, but enables testing of the UPS internal functionality.

To turn the UPS to maintenance bypass:

1. Follow the normal start position:

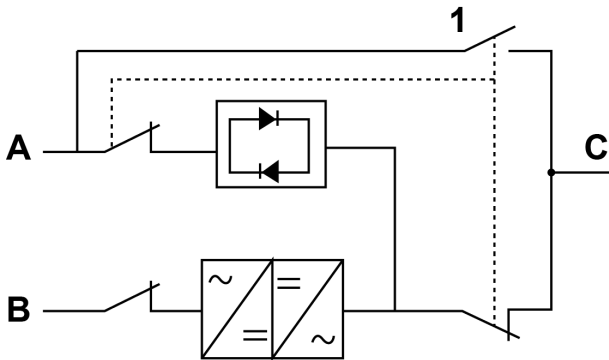

Figure 45. Normal positions of the MBS switches and rectifier disconnect switch (must be located in the site wiring)

- | | | | |
|---|---------------------|---|---------------------------------|
| A | Static bypass input | 1 | Maintenance Bypass Switch (MBS) |
| B | Rectifier input | | |
| C | Out | | |

2. Perform the transfer from the double conversion mode to the bypass mode as instructed in Section 7.3.3. Remember to verify the transfer before proceeding to the next step.
3. Turn the MBS from the UPS position to the Test position and then to the Bypass position.
4. Perform the LOAD OFF procedure as described in Section 7.3.8.
5. Turn off the rectifier switch to disconnect the UPS rectifier input.
6. Turn off the static bypass switch to disconnect the UPS bypass input.

The UPS is now in the maintenance bypass mode:

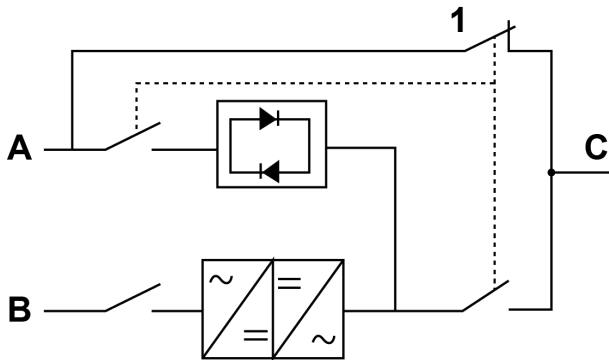

Figure 46. Maintenance bypass mode

- | | | | |
|---|---------------------|---|---------------------------------|
| A | Static bypass input | 1 | Maintenance Bypass Switch (MBS) |
| B | Rectifier input | | |
| C | Out | | |

7.8 Turning the UPS from the maintenance bypass mode to the double conversion mode

To turn the UPS back to the double conversion mode:

1. Follow the normal start position:

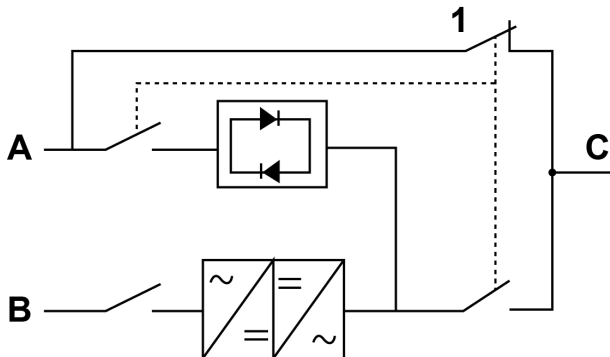

Figure 47. Maintenance bypass mode

- | | | | |
|---|---------------------|---|---------------------------------|
| A | Static bypass input | 1 | Maintenance Bypass Switch (MBS) |
| B | Rectifier input | | |
| C | Out | | |
2. Turn on the rectifier switch to connect rectifier input to the UPS.

3. Turn on the static bypass switch to connect bypass input to the UPS.
4. Turn the MBS from the bypass position to the test position.
5. Perform the UPS start-up procedure (bypass mode) in Section 7.3.2.
6. Turn the MBS from the test position to the UPS position.
7. Perform the transfer from the bypass mode to the double conversion mode as described in Section 7.3.4.

The UPS is now in the double conversion mode.

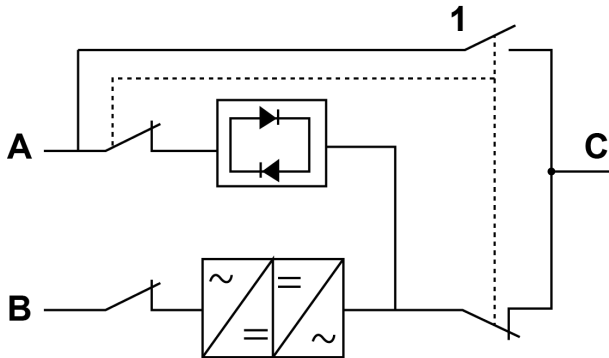

Figure 48. Double conversion mode

- | | | | |
|---|---------------------|---|---------------------------------|
| A | Static bypass input | 1 | Maintenance Bypass Switch (MBS) |
| B | Rectifier input | | |
| C | Out | | |

8 UPS maintenance

The components inside the UPS cabinet are secured to a sturdy metal frame. All repairable parts and assemblies are located for easy removal with very little disassembly. This design allows authorized service personnel to perform routine maintenance and servicing quickly. Schedule periodic performance checks of your UPS system to keep it running properly. Regular routine checks of the operation and system parameters enable your system to function efficiently for many trouble-free years.

8.1 Important safety instructions

Remember that your UPS system is designed to supply power **EVEN WHEN IT IS DISCONNECTED FROM THE UTILITY POWER**. The UPS module interiors are unsafe until the DC power source is disconnected and the electrolytic capacitors are discharged.

After disconnecting the utility power and the DC power, authorized service personnel must wait at least 5 minutes for capacitor bleed-off before attempting internal access to the UPS module.



DANGER

LETHAL VOLTAGE. Do not operate the UPS system without the cabinet doors or protective panels secured. Do not make any assumptions about the electrical state of any cabinet in the UPS system.



WARNING

All service and maintenance work must be performed only by service personnel qualified and authorized by Eaton.



CAUTION

A warning label, shown in Figure 49, must be installed at the UPS input terminals and all the primary power isolators used to isolate the UPS unit if the UPS input is connected through external isolators that, when opened, isolate the neutral. You can get these warning labels from your local service representative.

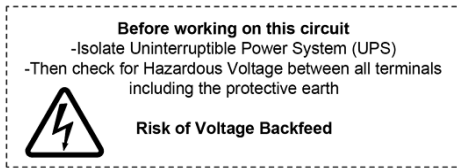

Figure 49. Warning label

Since each battery string is an energy source in itself, opening the battery circuit breaker does not de-energize the voltage within the battery string.



DANGER

Do not attempt to access any internal area of the battery string. Voltages are always present in the battery strings. If you suspect that a battery string needs service, contact your service representative.

8.2 Preventive maintenance

The UPS system needs very little preventive maintenance. However, inspect the system periodically to verify that the units are operating normally and that the batteries are in good condition.

The majority of the service and maintenance work must be done by service personnel qualified by Eaton. Only the actions described in Section 8.2.1 and Section 8.2.2 can be done by the user.

8.2.1 Daily maintenance

Do this every day:

1. Examine the area surrounding the UPS system. Make sure that the area is not cluttered, allowing free access to the unit.
2. Examine that the air intakes (vents on the front door of the UPS cabinet) and the exhaust openings (at the rear of the UPS cabinet) are not blocked.
3. Make sure that the operating environment is within the parameters specified in Section 4.3.1 and Chapter 9.
4. Examine that the UPS is in the normal mode (the normal mode status indicator is illuminated). If an alarm lamp is lit or the normal mode status indicator is not lit, contact an Eaton service representative.

8.2.2 Monthly maintenance

Do this once a month:

1. Examine the system parameters on the control panel (see Section 7.1.4).

2. If the optional air filters are installed, examine them (located behind the front doors) and wash or replace them, if needed. Contact your service representative for replacement filters. To replace the filters:
 - a. Open the UPS front door.
 - b. Replace the filters.
 - c. Close the UPS front door.
3. Record the check results and any corrective actions in a service log.

8.2.3 Periodic maintenance

Inspect the UPS periodically to determine if components, wiring, and connections exhibit evidence of overheating. Pay particular attention to bolted connections. Bolted connections must be re-torqued periodically.

8.2.4 Annual maintenance



WARNING

Only authorized personnel that are familiar with the maintenance and servicing of the UPS system can do the annual preventive maintenance. Contact your service representative for more information about service offerings.

8.2.5 Battery maintenance



WARNING

Only authorized personnel can do the battery replacement and maintenance. Contact your service representative for battery maintenance.

8.3 Recycling the used UPS or batteries

Remove the battery bank before disposing of the UPS or its battery cabinet. Obey the local requirements regarding battery recycling or disposal.



WARNING

Only authorized personnel can remove the batteries due to the risk caused by high energy and voltage.

Do not discard waste electrical or electronic equipment in the trash. For proper disposal, contact your local collecting/recycling/reuse or hazardous waste center and follow the local legislation.

These symbols indicate a product requiring special handling:

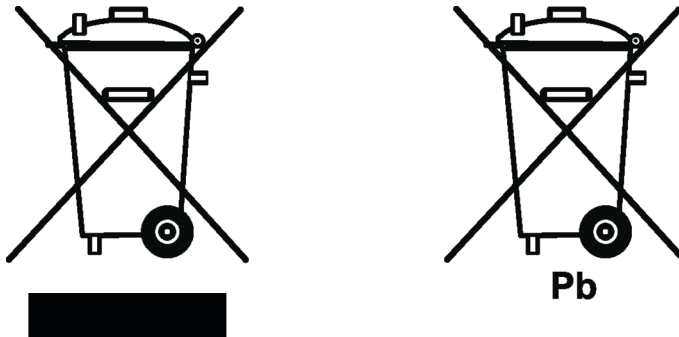

Figure 50. WEEE symbol (left) and battery recycling symbol

When you handle waste from electrical and electronic equipment, use proper local collecting centers that meet local legislation.



WARNING

HAZARDOUS MATERIALS.

Batteries can contain high voltages and caustic, toxic and flammable substances. If used improperly, batteries can injure or kill people and damage equipment.

Do not discard of unwanted batteries or battery material in the public waste disposal system. Obey all the applicable local regulations regarding the storage, handling and disposal of batteries and battery materials.

8.4 Maintenance training

For more information about training and other services, contact your Eaton representative.

9 Technical data

For a complete technical specification, contact your Eaton representative. Due to continuous product improvement programs, specifications are subject to change without notice.

9.1 Directives and standards

| | |
|--------------------------------|--|
| Safety | IEC 62040-1: Uninterruptible power systems (UPS) - Part 1: General and safety requirements for UPS IEC 60950-1: Information technology equipment - Safety - Part 1: General requirements |
| EMC, emissions | IEC 62040-2: Uninterruptible power systems (UPS) - Part 2: Electromagnetic compatibility (EMC) requirements / Ed. 2 |
| EMC, immunity | IEC 61000-2: Electromagnetic compatibility (EMC), IEC 61000-2-2 (Low-frequency conducted), IEC 61000-4-2 (ESD), IEC 61000-4-3 (RF electromagnetic field), IEC 61000-4-4 (Fast transient-burst), IEC 61000-4-5 (Surge), IEC 61000-4-6 (Conducted RF common mode), IEC 61000-4-8 (Power frequency magnetic field) |
| Performance & tests | IEC 62040-3: Uninterruptible power systems (UPS) - Part 3: Method of specifying the performance and test requirements |
| Environmental | IEC62040-4: Uninterruptible Power Systems (UPS) - Part 4: Environmental Aspects - Requirements and Reporting IEC 62430: Environmentally conscious design for electrical and electronic products |
| RoHS | 2011/65/EU on the restriction of the use of certain hazardous substances in electrical and electronic equipment |
| WEEE | 2012/19/EU on waste electrical and electronic equipment (WEEE) |
| ECO Design Directive | 2009/125/EC establishing a framework for the setting of ecodesign requirements for energyrelated products |
| Batteries | 2006/66/EC on batteries and accumulators and waste batteries and accumulators |
| Packaging | 94/62/EC on packaging and packaging waste |

9.2 UPS system input

| | |
|---|---|
| Rated input voltage | 220/380 V; 230/400 V; 240/415 V |
| Voltage tolerance (Rectifier input) | 30-200 kW UPS: 400 V -20% / +20% 60-250 kVA UPS: 400 V -15% / +20% |
| Voltage tolerance (Bypass input) | 400 V -10% / +10% |
| Rated input frequency | 50 or 60 Hz, user configurable |
| Frequency tolerance | 42 to 72 Hz |
| Number of input phases (rectifier & bypass) | 3 phases, + N |
| Input power factor | 0.99 |
| Rated/maximum mains input current | See Table 10 |
| Input current distortion at rated input current, iTHD | 30 kVA: <5% 40-250 kVA: <3% |
| Rectifier ramp-up, rectifier start and load step | 10 A/s (default), configurable. Min 1 A/s |
| Backfeed protection | Yes, for rectifier and bypass lines |

9.3 UPS system output

| | |
|--|--|
| Number of output phases | 3 phases + N |
| Rated output voltage | 220/380 V; 230/400 V; 240/415 V; configurable |
| Rated output frequency | 50 or 60 Hz, configurable |
| Total voltage harmonic distortion: 100 % linear load | 30-200 kW UPS: < 1.2% 60-250 kVA UPS: < 1.5% |
| Slew rate | 0.4 Hz/s |
| Output current | See Table 10 |
| Overload capability (on inverter) 30, 40, 80, 120, 160 kW UPS | 10 min 135% 60 s 155% 10 s 185% 300 ms > 185% |
| Overload capability (on inverter, stored energy mode) 30, 40, 80, 120, 160 kW UPS | 10 min 135% 60 s 155% 300 ms > 155% |

| | |
|--|---|
| Overload capability (on inverter) 50, 100, 150, 200 kW UPS | 10 min 110% 60 s 125% 10 s 150% 300 ms > 150% |
| Overload capability (on inverter, stored energy mode) 50, 100, 150, 200 kW UPS | 10 min 110% 60 s 125% 300 ms > 125% |
| Overload capability (on inverter) 60, 120, 180, 250 kVA UPS | 60 s 105% 10 s 125% |
| Overload capability (on inverter, stored energy mode) 60, 120, 180, 250 kVA UPS | 60 s 105% 400 ms > 105% |
| Overload capability (bypass mode) | 30-200 kW UPS: continuous <125% 60-250 kVA UPS: continuous <115% |
| Load power factor (rated) | 30-200 kW UPS: 1.0 60-250 kVA UPS: 0.9 |
| Load power factor (permitted range) | From 0.8 lagging to 0.8 leading |

9.4 UPS environmental specifications

| | |
|--|---|
| Acoustic noise at 1 m | 30-60 kVA UPS: <60 dBA 80-250 kVA UPS: <65 dBA ESS operation: <45 dBA |
| Ambient UPS storage temperature range | UPS: -25 °C to +55 °C in the protective package Internal and external VRLA battery: -25 °C to +25 °C in the protective package* *) Recommended for optimized battery lifetime |
| Ambient operating temperature range | 30-200 kW UPS: +5 °C to +40 °C 60-250 kVA UPS: +5 °C to +35 °C Internal and external VRLA battery: +20 °C to +25 °C for optimized battery lifetime |
| Relative humidity range | 5 to 95%, no condensation allowed |

| | |
|---|---|
| Maximum service altitude | 1,000 m (3,300 ft) above sea level at rated maximum ambient temperature Maximum 2,000 m (6,600 ft) with 1% derating per each additional 100 m above 1,000 m. |
| Maximum storage time with internal batteries | 6 months without discharge |

9.5 Battery specification

| | |
|------------------------------------|---|
| Battery type | VRLA, 12 VDC |
| Recharge profile | Advanced Battery Management (ABM) or float charge |
| End of discharge voltage | 1.67 VPC to 1.75 VPC, configurable or automatic (load adaptive) |
| Battery start option | Yes |
| Charging current capability | Configurable, 0 to 29.3 A / UPM |

| 93 PM UPS kVA | 30, 40, 50 kW or 60 kVA with internal battery | 30, 40, 80, 120 or 160 kW, no internal battery | 50, 100, 150 or 200 kW, no internal battery | 120, 180 or 250 kVA, no internal battery |
|--------------------------------------|---|--|---|--|
| Battery quantity, per battery string | 36 blocks, 216 cells | 32 to 40 blocks, 192 to 240 cells | 36 to 40 blocks, 216 to 240 cells | 40 blocks, 240 cells |
| Battery voltage range | 432 V (36 blocks) | 384 V (32 blocks) to 480 V (40 blocks) | 432 V (36 blocks) to 480 V (40 blocks) | 480 V (40 blocks) |



Note:

Do not connect battery strings with different battery quantity and voltage in parallel!

10 Warranty

10.1 General

The product is warranted against defects in materials and workmanship for a period of twelve (12) months from its original date of purchase. The local office or distributor may grant a warranty period different to the above. Please refer to local terms of liability as defined in the supply contract.

The UPS manufacturer is not responsible for:

- Any costs resulting from a failure if the installation, commissioning, repair, alteration, or ambient conditions of the equipment do not fulfill the requirements specified in the documentation delivered with the unit and other relevant documentation.
- Equipment subjected to misuse, negligence or accident.
- Equipment comprised of materials provided or designs stipulated by the purchaser.

The warranty is only valid if the installation inspection and initial startup of the UPS unit is carried out by an authorized Eaton Customer Service Engineer or by other qualified service personnel authorized by Eaton. Service and maintenance of the UPS shall also be performed only by an authorized Eaton Customer Service Engineer or by other qualified service personnel authorized by Eaton. Otherwise the warranty will be voided.

If the product fails to meet its published specifications due to a defect in material and workmanship, covered by this warranty, the seller will repair or replace the warranted product. Such repair or replacement will be made by Eaton or by a service provider approved by Eaton. Repair or replacement during the warranty period does not extend the original warranty. Warranty does not cover taxes, which will be due in connection with replacement or repair of the product.

Batteries are warranted against failures in material and workmanship, not against the normal aging and reduction of ampere-hour capacity. The product storage environment has to meet manufacturer's specifications, failure to do this will cause the warranty to be voided.

Under no circumstances shall the manufacturer, its suppliers or subcontractors be liable for special, indirect, incidental or consequential damages, losses or penalties.

The technical data, information and specifications are valid at the time of printing. The UPS manufacturer reserves the right to modifications without prior notice.

10.2 Whom to contact in case of Warranty

In case of Warranty, or while unsure if the unit in question is covered by warranty, contact the respective sales organization where the unit was purchased. Have the following information available:

- Purchase order number and purchase order date
 - Installation date
- OR
- Serial number and part number of the unit (information available on the unit's label)

Appendix A: Relay Alarms

| Name | ID |
|---------------------------------|-----|
| 24V Power Supply Failed | 73 |
| 5V Power Supply Failed | 72 |
| ABM Active | 232 |
| ABM Enable | 231 |
| ABM Installed | 230 |
| ABM State Reset | 91 |
| ABM State Charging | 88 |
| ABM State Floating | 89 |
| ABM State Resting | 90 |
| Adaptive Overload Capacity Off | 116 |
| Adaptive Overload Capacity Off | 326 |
| Alternate Sync (Sync Box) | 317 |
| Alternate Sync Error | 318 |
| Ambient Over Temperature | 94 |
| Auto calibration in progress | 321 |
| Automatic Start Up Pending | 263 |
| Backfeed Switchgear Closed | 203 |
| Backfeed Switchgear Failed | 204 |
| Batteries Disconnected | 50 |
| Battery Backup Power Failure | 458 |
| Battery Breaker Open/Closed | 102 |
| Battery Breaker Open/Closed | 322 |
| Battery Current Over Limit | 12 |
| Battery DC Over Voltage | 19 |
| Battery DCUV Trip Imminent | 107 |
| Battery Discharging | 61 |
| Battery In Common | 25 |
| Battery Installed | 63 |
| Battery Installed | 209 |
| Battery Over Temperature Trip | 93 |
| Battery Over Temperature | 92 |
| Battery Startup Failure | 108 |
| Battery Switchgear Failed | 70 |
| Battery Switchgear Open/ Closed | 64 |
| Battery Test Aborted | 460 |
| Battery Test Failed | 46 |

| Name | ID |
|---------------------------------------|-----|
| Battery Test In Progress | 60 |
| Battery Test Cancel Command | 439 |
| Battery Test Command | 438 |
| Boost Charging Active | 327 |
| Boost Charging Available | 328 |
| Boost Charging Installed | 330 |
| Bypass AC Over Voltage | 192 |
| Bypass AC Under Voltage | 193 |
| Bypass Breaker Active | 278 |
| Bypass Breaker Installed | 277 |
| Bypass Command | 385 |
| Bypass Hot | 206 |
| Bypass Installed | 207 |
| Bypass Not Available | 202 |
| Bypass Over Temperature | 290 |
| Bypass Over Temperature Trip | 319 |
| Bypass Phase Rotation | 201 |
| Bypass Service Button On | 315 |
| Bypass Sync Out of Range | 268 |
| Bypass Under/ Over Frequency | 194 |
| Charger Failed | 84 |
| (UPM received) Charger Off Command | 41 |
| Charger Off Command (issued from CSB) | 437 |
| Charger On Command (issued from CSB) | 436 |
| Charger On Command | 42 |
| Charger On/Off | 56 |
| Check CSB EEPROM | 419 |
| Check Pull Chain | 82 |
| Check Pull Chain | 235 |
| Check System Type Configuration Error | 461 |
| Chimney Ambient Over Temperature | 303 |
| Chimney Fan Failed | 304 |
| Clear Alarms | 421 |
| Clear Call Service | 422 |
| Clear Maintenance Reminder | 424 |
| Clear Status Command | 450 |
| Clear Warranty Reminder | 423 |
| Clock Set Done | 427 |

| Name | ID |
|---|-----|
| Command Received | 294 |
| Configuration Error | 53 |
| CSB Control Power | 425 |
| CSB EEPROM Version Downgrade | 464 |
| CSB Software Incompatible | 426 |
| DC Link Over Voltage | 10 |
| DC Link Under Voltage | 11 |
| Disable ABM Command | 447 |
| Disable ESS Command | 444 |
| Disable HRS Command | 456 |
| Disable Service Mode Command | 441 |
| Disable VMMS Command | 446 |
| Distributed Parallel System | 276 |
| ECT Command (UPM) | 86 |
| ECT Command | 257 |
| Emergency Transfer to Bypass | 241 |
| Enable ABM Command | 448 |
| Enable Auto Calibration Command | 462 |
| Enable ESS Command | 444 |
| Enable High Alert Command | 459 |
| Enable HRS Command | 457 |
| Enable Service Mode Command | 440 |
| Enable VMMS Command | 446 |
| ESS Active | 213 |
| ESS Enabled | 226 |
| ESS Installed | 225 |
| ESS Inverter Gapping | 5 |
| ESS Not Available | 307 |
| Exit ECT Mode Abnormally | 80 |
| Exit ESS Mode | 205 |
| External CAN Abnormal or Configuration Mismatch | 265 |
| External communications failure | 463 |
| Fan Failed | 48 |
| Fan Power Board Cool Fan Failed | 305 |
| Frequency Auto Detected | 309 |
| Fuse Failed | 47 |
| Ground Wiring Fault | 264 |
| High Alert | 308 |

| Name | ID |
|---------------------------------|-----|
| Horn is Buzzing | 418 |
| HRS Active | 283 |
| HRS Enabled | 282 |
| HRS Installed | 281 |
| I2C Bus Failed | 115 |
| Input AC Over Voltage | 2 |
| Input AC Under Voltage | 3 |
| Input Sync Out of Range | 75 |
| Input Sync Out of Range | 269 |
| Input Under/ Over Frequency | 4 |
| Internal CAN Bus Failed | 109 |
| Internal CAN Bus Failed | 310 |
| Internal Communications Failure | 414 |
| Internal Redundant System | 275 |
| Inverter AC Over Voltage | 1 |
| Inverter AC Under Voltage | 0 |
| Inverter Fault | 7 |
| Inverter Matched to Output | 105 |
| Inverter On/Off | 23 |
| Inverter Output Over Current | 9 |
| Inverter Over Temperature | 6 |
| Inverter Over Temperature Trip | 68 |
| Inverter Overload Trip | 71 |
| Inverter Startup Failure | 76 |
| Inverter Switchgear Closed | 62 |
| Inverter Switchgear Failed | 67 |
| Load Off Command | 386 |
| Load Off Command | 223 |
| Load Power Off | 297 |
| Loss of Sync Bus | 79 |
| Loss of PWM Sync | 114 |
| Low Battery Shutdown | 43 |
| Low Battery Warning | 15 |
| Maintenance Out of Date | 428 |
| MBS Installed | 208 |
| MCU 24V Power Supply Failed | 255 |
| MCU 5V Power Supply Failed | 254 |
| MCU Configuration Error | 239 |

| Name | ID |
|----------------------------------|-----|
| MCU Control Power | 289 |
| MCU EEPROM Checksum Failed | 240 |
| MCU Software Incompatible | 210 |
| MIS Installed | 291 |
| MIS Open/Closed | 292 |
| MOB Open | 279 |
| Not Enough Bypass Capacity | 272 |
| Not Enough Redundant UPMs | 323 |
| Not Enough UPMs | 271 |
| On Alarm LED Is Lit | 416 |
| On Battery LED Is Lit | 260 |
| On Bypass LED Is Lit | 261 |
| On MBS, Battery | 216 |
| On MBS, ESS Active | 298 |
| On MBS, HRS Active | 300 |
| On MBS, On Bypass | 218 |
| On MBS, Starting | 296 |
| On MBS, Shutdown | 219 |
| On MBS, Unit Online | 217 |
| On MBS, VMMS Active | 299 |
| On Notice LED Is Lit | 417 |
| On Line LED Is Lit | 262 |
| Online command | 384 |
| Output AC Over Voltage | 99 |
| Output AC Over Voltage | 196 |
| Output AC Under Voltage | 100 |
| Output AC Under Voltage | 195 |
| Output Hot | 236 |
| Output Not In Sync With Bypass | 286 |
| Output Not In Sync with Ext Sync | 287 |
| Output Overload Trip | 302 |
| Output Phase Rotation | 199 |
| Output Sync Out of Range | 267 |
| Output Under/ Over Frequency | 197 |
| Output Voltage Abnormal | 198 |
| Parallel Meters CAN Bus Failed | 415 |
| Parallel Setup Failure | 258 |
| Parameter Match Failed | 316 |

| Name | ID |
|----------------------------------|-----|
| Phase A Overload | 27 |
| Phase B Overload | 28 |
| Phase C Overload | 29 |
| PhaseA Overload Level2 | 30 |
| PhaseA Overload Level3 | 33 |
| PhaseA Overload Level4 | 36 |
| PhaseB Overload Level2 | 31 |
| PhaseB Overload Level3 | 34 |
| PhaseB Overload Level4 | 37 |
| PhaseC Overload Level2 | 32 |
| PhaseC Overload Level3 | 35 |
| PhaseC Overload Level4 | 38 |
| Precharge Failed | 54 |
| Pull Chain | 81 |
| Pull Chain | 234 |
| Pull Out Not Allowed | 112 |
| Rectifier Breaker Open | 18 |
| Rectifier Fault | 104 |
| Rectifier Input Over Current | 8 |
| Rectifier On/Off | 55 |
| Rectifier Over Temperature | 52 |
| Rectifier Over Temperature Trip | 69 |
| Rectifier Phase Rotation | 21 |
| Rectifier Startup Failure | 66 |
| Rectifier Switchgear Open/Closed | 78 |
| Remote Emergency Power Off | 200 |
| Reset Alarms Command | 449 |
| Reset History LOG | 420 |
| Restart Command | 435 |
| Service Battery | 26 |
| Service Required | 453 |
| Shutdown Command | 434 |
| Shutdown Imminent | 237 |
| Signal Input 1 On | 407 |
| Signal Input 2 On | 408 |
| Signal Input 3 On | 409 |
| Signal Input 4 On | 410 |
| Signal Input 5 On | 411 |

| Name | ID |
|---|-----|
| Signal Input 6 On | 412 |
| Signal Input 7 On | 413 |
| Signal Input 8 On | 451 |
| Signal Input 9 On | 452 |
| Signal Input Battery Disconnected | 402 |
| Signal Input Bypass Sync Disabled | 400 |
| Signal Input Charger Off | 392 |
| Signal Input Disable Battery Charge and Discharge | 401 |
| Signal Input Forced Maintenance Bypass | 404 |
| Signal Input Maintenance Bypass | 403 |
| Signal Input MIS Open | 406 |
| Signal Input MOB Open | 405 |
| Signal Input On Generator | 397 |
| Signal Input Remote ESS Command | 395 |
| Signal Input Remote Go to Bypass | 389 |
| Signal Input Remote Load Off | 390 |
| Signal Input Remote Power Module Off | 391 |
| Signal Input Remote Rectifier Off | 398 |
| Signal Input Remote Sync | 399 |
| Signal Input Remote UPS On | 388 |
| Signal Input Remote VMMS Command | 394 |
| Signal Input Remote VMMS/ESS Off | 393 |
| Signal Input Reset Alarms | 396 |
| Signal Input Transformer Over Temperature | 465 |
| Signal Input | 331 |
| Single UPS System | 274 |
| Site Wiring Fault | 49 |
| Site Wiring Fault | 284 |
| SPI Bus Failed | 77 |
| SPI Bus Failed | 266 |
| Start Boost Charge Command | 470 |
| Start ECT Command | 454 |
| Static Switch Active | 280 |
| Static Switch On | 430 |
| Static Switch Short | 224 |
| Stop Boost Charge Command | 471 |
| Stop ECT Command | 455 |
| STS Ambient Over Temperature | 301 |

| Name | ID |
|---|-----|
| STS Fan Failed | 288 |
| System Not Redundant | 233 |
| System On Bypass | 312 |
| System On Maintenance Bypass | 270 |
| System Overload | 311 |
| System Test in Progress | 259 |
| To Bypass Command | 221 |
| Too Many EEP Written Operation | 468 |
| Too Many Inverter Transfers | 65 |
| Too Many Inverter Transfers | 285 |
| Too Many Battery Transfers | 106 |
| Transformer Fan Failed | 324 |
| Transformer Over Temperature Trip | 325 |
| Turn Off Battery Command | 433 |
| Turn to Battery Command | 432 |
| UPM Command | 83 |
| UPM Connection Fail | 111 |
| UPM Control Power | 22 |
| UPM Critical Parameters Sync In Process | 113 |
| UPM EEPROM Checksum Failed | 13 |
| UPM Hardware ID Mismatching | 320 |
| UPM Hot | 24 |
| UPM in Service Mode | 97 |
| UPM Normal, On ESS Mode | 95 |
| UPM Normal, On VMMS | 96 |
| UPM Not Responding | 367 |
| UPM Off Command | 40 |
| UPM On Battery | 58 |
| UPM On Command | 323 |
| UPM On ECT | 87 |
| UPM On Normal | 59 |
| UPM On Command | 39 |
| UPM Remote Emergency Power Off | 45 |
| UPM Selective Trip | 51 |
| UPM Shutdown Imminent | 14 |
| UPM Software Incompatible | 44 |
| UPM State Request | 57 |
| UPM Test Command | 378 |

| Name | ID |
|----------------------------|-----|
| UPM Unlock | 110 |
| UPMs Not Redundant | 314 |
| UPS Exit ECT Process | 306 |
| UPS Normal Command | 222 |
| UPS Not Redundant | 313 |
| UPS On Battery | 215 |
| UPS On Bypass | 211 |
| UPS On Generator | 220 |
| UPS PhaseA Output Overload | 242 |
| UPS PhaseA Overload Level2 | 245 |
| UPS PhaseA Overload Level3 | 248 |
| UPS PhaseA Overload Level4 | 251 |
| UPS PhaseB Output Overload | 243 |
| UPS PhaseB Overload Level2 | 246 |
| UPS PhaseB Overload Level3 | 249 |
| UPS PhaseB Overload Level4 | 252 |
| UPS PhaseC Output Overload | 244 |
| UPS PhaseC Overload Level2 | 247 |
| UPS PhaseC Overload Level3 | 250 |
| UPS PhaseC Overload Level4 | 253 |
| UPS Ready | 238 |
| UPS Shutdown | 212 |
| UPS Starting | 293 |
| UPS System Off | 273 |
| UPS System Online | 214 |
| Utility Not Available | 16 |
| Warranty Out of Date | 429 |
| VMMS Not Available | 256 |
| VMMS Active | 229 |
| VMMS Enable | 228 |
| VMMS Installed | 227 |



Powering Business Worldwide

Eaton Power Quality Oy
Koskelontie 13
FI-02920 Espoo, Finland
www.eaton.eu

Copyright © 2018 Eaton Corporation plc. All rights reserved. Unauthorized copying and lending are prohibited.