

**White Paper**  
**Enabling Converged 4G and 5G Mobile Fronthaul**

October 2017



# 1 Revision History

---

The revision history describes the changes that were implemented in the document. The changes are listed by revision, starting with the most current publication.

## 1.1 Revision 1.0

Revision 1.0 was the first release of this document.

## 1.2 Revision 2.0

The following was updated for Revision 2.0:

- latency number updated to 2.5  $\mu$ s based on measured test results
- added support for CPRI option 10
- Section 5.1 updated to include network slicing and support for switched network applications
- Minor edits to figures 8 and 16
- Added figure 15

# Contents

---

- 1 Revision History..... 2
  - 1.1 Revision 1.0..... 2
  - 1.2 Revision 2.0..... 2
- 2 Radio Access Network Evolution from 4G to 5G..... 6
  - 2.1 Evolving from LTE to LTE-Advanced..... 6
  - 2.2 Evolving to 5G ..... 8
  - 2.3 Summary of the Evolution from 4G to 5G ..... 8
- 3 Conventional WDM Fronthaul Solutions ..... 10
- 4 The Case for 100G OTN-Based Mobile Fronthaul ..... 12
  - 4.1 100G OTN vs. Conventional WDM for Fronthaul ..... 12
  - 4.2 Economics of 100G OTN vs. Conventional WDM..... 13
  - 4.3 Summary..... 14
- 5 Microsemi’s Mobile Fronthaul Solution ..... 15
  - 5.1 Microsemi Innovations to Enable 4G and 5G Fronthaul ..... 16
  - 5.2 Summary of the DIGI-G4 Mobile Fronthaul Solution..... 17
- 6 Conclusion..... 18
- 7 References..... 19

# Figures

---

- Figure 1 Mobile Network Evolution: From Traditional RAN to C-RAN ..... 5
- Figure 2 Typical LTE Network Equipment ..... 6
- Figure 3 Example Use Cases for the Evolution to CPRI Option 5 (4.9 Gbps) ..... 7
- Figure 4 Example Use Cases for the Evolution to CPRI Option 7 (9.8 Gbps) ..... 7
- Figure 5 Summary of Mobile Evolution from 4G to 5G ..... 8
- Figure 6 Converged 4G and 5G Network ..... 9
- Figure 7 Conventional Passive and Active WDM Fronthaul Solutions..... 10
- Figure 8 Comparing Passive/Active WDM and Fronthaul Requirements ..... 11
- Figure 9 Metro vs. Mobile Network Evolution ..... 12
- Figure 10 Conventional WDM Solution for Converged 4G and 5G Fronthaul ..... 12
- Figure 11 100G OTN Solution for Converged 4G and 5G Fronthaul ..... 13
- Figure 12 Optical Transceiver Cost for 100G OTN and Conventional WDM Systems ..... 14
- Figure 13 Converged 4G and 5G Fronthaul Network Enabled by Microsemi ..... 15
- Figure 14 Microsemi’s Groundbreaking DIGI-G4 Based Mobile Fronthaul Solution ..... 16
- Figure 15 Network Slicing Enabled and Switched Mobile Transport Network ..... 17
- Figure 16 DIGI-G4-based 100G OTN Fronthaul vs. Conventional WDM Solutions ..... 17

## Introduction

Mobile data traffic continues to increase exponentially. In the November 2016 issue of the Ericsson Mobility Report [1], Ericsson reported that data traffic on the world's mobile networks increased 50% year over year between Q3 2015 and Q4 2016. Ericsson forecasts this trend to continue, as mobile traffic grows at a 45% Compound Annual Growth Rate (CAGR) between 2016 and 2022, reaching 8x current traffic levels. Meanwhile, fierce competition among mobile network operators and consumer demand for an ever-faster network is leading operators to add capacity at unprecedented rates. While the initial LTE rollout for coverage purposes has largely completed, operators are now focused on two primary activities:

- Adding capacity to their 4G network with LTE-A and cell-site densification
- Preparing for 5G

Both of these megatrends are causing mobile operators worldwide to embrace the Centralized Radio Access Network (C-RAN) architecture. In their June 2016 report on C-RAN [2], IHS Markit forecasts that the equipment market for baseband equipment (BBU) sold into C-RAN deployments will exceed \$12 billion (USD) in 2020, representing approximately 70% of the BBU spend in that year.

As shown in the following illustration, the fundamental concept behind C-RAN is to move the BBUs for all nearby cell-sites and small cells to a centralized location. While C-RAN presents many advantages, one significant challenge it creates is the need for a high capacity and low latency fronthaul network. A fronthaul network transports Common Public Radio Interface (CPRI) signals between the Remote Radio Heads (RRH) at the cell-sites and the BBUs in the central office or data center. As networks evolve to 5G, the fronthaul network will need to not only support CPRI, but Ethernet as well.

**Figure 1 Mobile Network Evolution: From Traditional RAN to C-RAN**

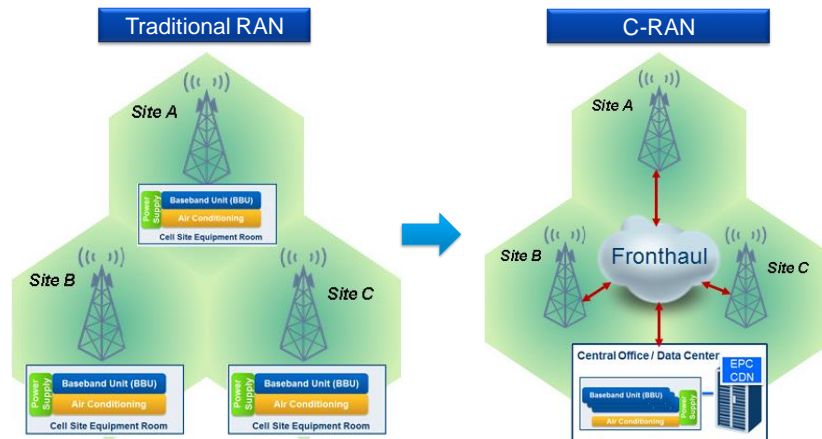

The key question for mobile network operators is: “What is the best possible way for me to connect my radios to my baseband with technology that meets the requirements for fronthaul today and scales to 5G?” This white paper will answer this question.

## 2 Radio Access Network Evolution from 4G to 5G

Mobile network deployments typically take place in two overall phases: a coverage phase in which service is provided over a broad area and a capacity phase to enhance the service offered. From an LTE perspective, many of the world's major mobile operators have largely completed their coverage deployment and are now turning their attention to capacity. Let's examine how capacity can be added to a mobile network.

### 2.1 Evolving from LTE to LTE-Advanced

Today, a typical LTE network would feature a 20 MHz carrier transmitted by two antennas per sector, as shown in the following illustration. CPRI transports this 20 MHz carrier signal in baseband form between the RRH and the BBU.

**Figure 2 Typical LTE Network Equipment**

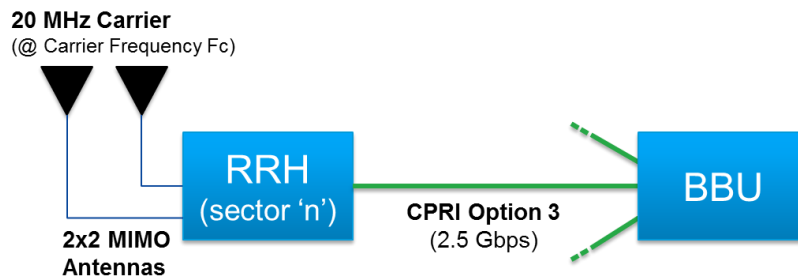

The CPRI signal rate scales proportionally with the total carrier bandwidth and the number of antennas. In this example, CPRI option 3 at ~2.5 Gbps is required for a 2x2 MIMO system transmitting a single 20 MHz carrier. A 3-sector macro-cell site may require three such CPRI signals.

Generally, there are three ways (or a combination thereof) in which a mobile operator can add capacity to their network:

- Evolve to higher order MIMO (such as 4x4 or 8x8) by adding additional antennas
- Add additional LTE carriers by deploying LTE-A carrier aggregation
- Densify the network by adding radios, for instance with sector-splitting or small cells

This evolution to a higher capacity network has an important impact on the C-RAN fronthaul network. The first two options both result in the need for a higher rate CPRI signal, while option 2 and option 3 in particular lead to more CPRI signals that need to be fronthauled.

While CPRI option 3 (2.5Gbps) was heavily used in the earliest LTE deployments, CPRI option 5 (4.9 Gbps) and CPRI option 7 (9.8 Gbps) are now becoming mainstream.

The following illustration demonstrates that CPRI option 5 would be required for a system that supports 2 x 20 MHz carrier aggregation over a 2x2 MIMO system. It would also be required for a single 20 MHz carrier transmitted using 4x4 MIMO.

**Figure 3 Example Use Cases for the Evolution to CPRI Option 5 (4.9 Gbps)**

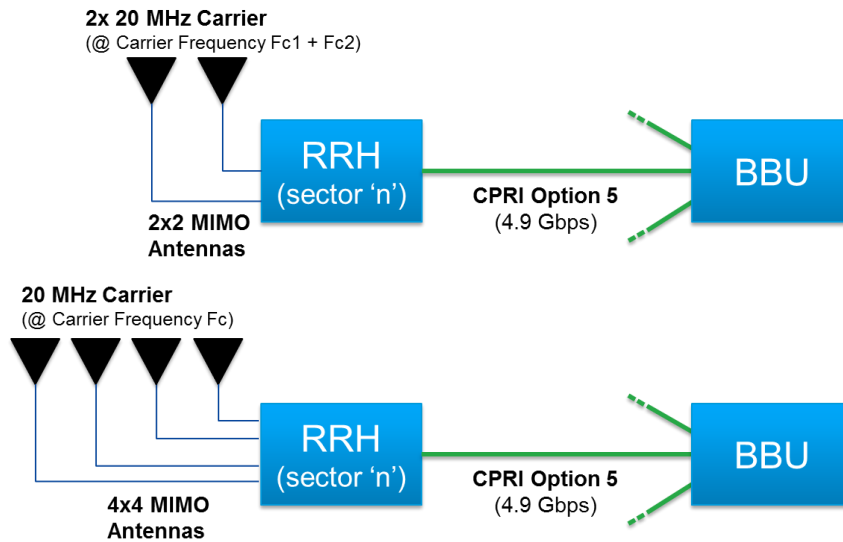

Typical use cases for CPRI option 7 demonstrated next. In this illustration, CPRI option 7 is required for 2 x 20 MHz carrier aggregation transmitted using a 4x4 MIMO system or for a single 20 MHz carrier transmitted using 8x8 MIMO.

**Figure 4 Example Use Cases for the Evolution to CPRI Option 7 (9.8 Gbps)**

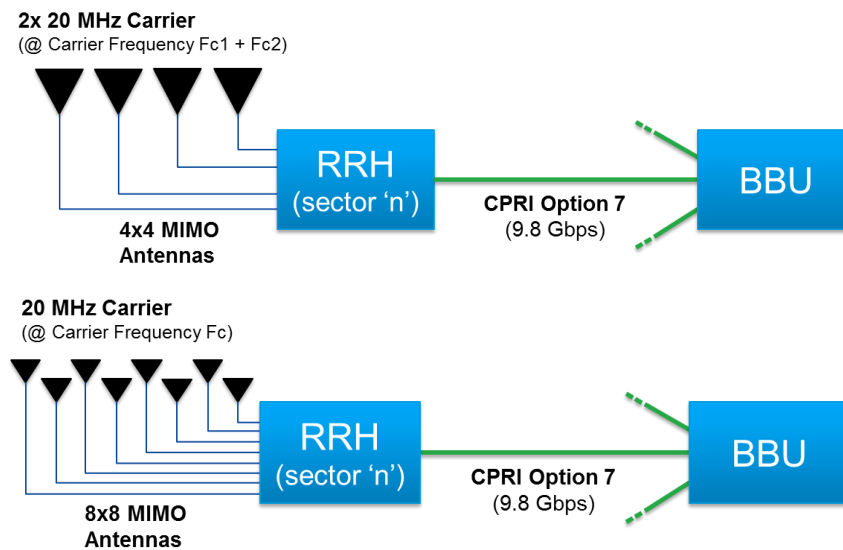

While CPRI option 3 was the dominant rate for LTE, CPRI option 5 and 7 are essential for a high capacity LTE-A network. Furthermore, mobile operators will densify their network through sector splitting (for instance, where a macro site moves from 3-sector to 6-sector) and the addition of small cells. Both of these methods add an additional dimension to the ways an operator will add capacity, putting additional strain on the fronthaul network.

## 2.2 Evolving to 5G

Of course, the mobile evolution does not stop at LTE-A. Multiple mobile operators have publically announced plans to commercially launch pre-standard 5G networks as early as 2018 with 3GPP-standard-based 5G networks not far behind. As operators deploy fronthaul networks in support of C-RAN, 5G must be considered.

In order to support the massive capacity promised by 5G networks, the two parameters most closely linked to fronthaul bandwidth will increase dramatically: carrier bandwidth and number of antennas. Carrier bandwidth is expected to increase into the hundreds of MHz range while massive MIMO could drive the need for hundreds of antenna elements. Depending on the specific use case, it is possible to see a 5G RRH handling 200 Gbps or more of baseband traffic.

Standards bodies are working to address this fronthaul bandwidth challenge while also enabling a data center-based, virtualized 5G network. 3GPP will standardize a re-partitioning of the protocol stack between the RRH and the BBU that will result in a fronthaul bandwidth reduction for 5G applications. The CPRI Cooperation, as well as IEEE, will define how to evolve from a CPRI-based interconnect to an Ethernet-based interconnect.

As a result, initial 5G networks will rely on dense 10GE and 25GE connections between the 5G remote radio head and the baseband processing unit.

In any event, fronthaul rates for 5G are set to increase substantially.

## 2.3 Summary of the Evolution from 4G to 5G

The following illustration shows how mobile networks will evolve from LTE through to 5G.

**Figure 5 Summary of Mobile Evolution from 4G to 5G**

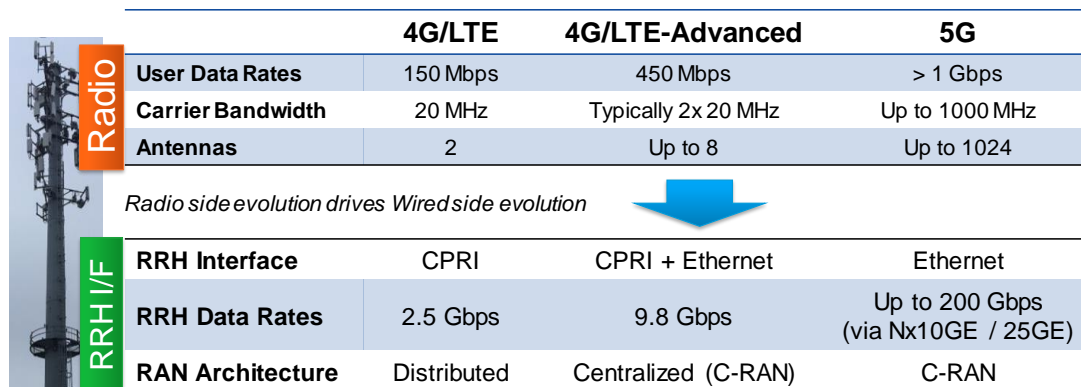

|   | 4G/LTE      | 4G/LTE-Advanced     | 5G                                    |
|---|-------------|---------------------|---------------------------------------|
| <b>Radio</b>  |             |                     |                                       |
| <b>User Data Rates</b>                                  | 150 Mbps    | 450 Mbps            | > 1 Gbps                              |
| <b>Carrier Bandwidth</b>                                | 20 MHz      | Typically 2x 20 MHz | Up to 1000 MHz                        |
| <b>Antennas</b>   | 2           | Up to 8             | Up to 1024                            |
| <i>Radio side evolution drives Wired side evolution</i> |             |                     |                                       |
| <b>RRH I/F</b>  |             |                     |                                       |
| <b>RRH Interface</b>                                    | CPRI        | CPRI + Ethernet     | Ethernet                              |
| <b>RRH Data Rates</b>                                   | 2.5 Gbps    | 9.8 Gbps            | Up to 200 Gbps<br>(via Nx10GE / 25GE) |
| <b>RAN Architecture</b>                                 | Distributed | Centralized (C-RAN) | C-RAN                                 |

From this, it can be seen that a truly cost-effective and future-proof fronthaul network must support dense CPRI interconnect at 9.8 Gbps for 4G services and support Ethernet at Nx10GE and Nx25GE for 5G services.

The result of these requirements is the need for the fronthaul network, as shown in the following illustration.



**Figure 6 Converged 4G and 5G Network**

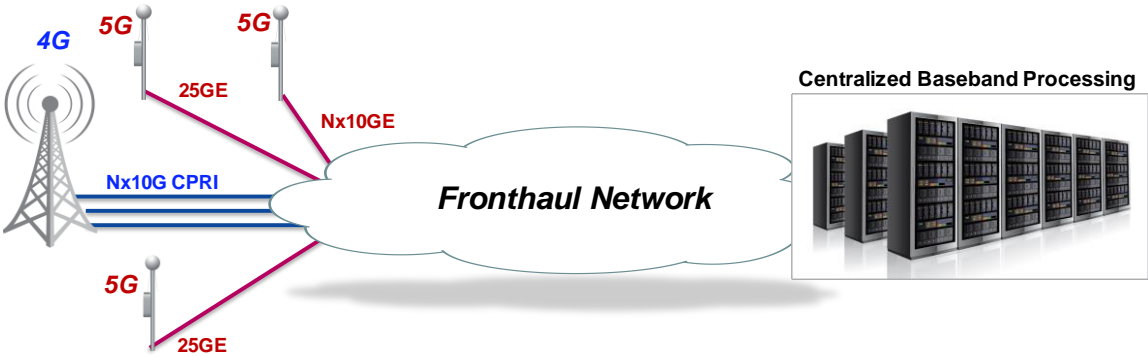

Moreover, as both 4G and 5G services will co-exist, the fronthaul network must be multiservice: supporting both CPRI and Ethernet simultaneously. As fronthaul evolves to Ethernet, so must the method for synchronization. Lastly, the fronthaul network must be secure against snooping and theft.

Let's look at possible solutions to this complex networking challenge.

### 3 Conventional WDM Fronthaul Solutions

While directly connecting RRHs to BBUs with fiber is possible, it is a costly and inefficient way to deploy a fronthaul network. As a result, mobile operators have sought alternatives. Two such alternatives are Passive and Active WDM.

As shown in the following illustration, both passive and active WDM leverage one pair of high-cost SFP+ WDM optical modules per CPRI client to effectively “colorize” the CPRI signals transmitted by the RRHs and the BBUs. A WDM multiplexer (MUX) is used to wavelength multiplex the colorized CPRI onto a fiber strand. At the receive end, a splitter de-multiplexes the colorized CPRI signals.

**Figure 7 Conventional Passive and Active WDM Fronthaul Solutions**

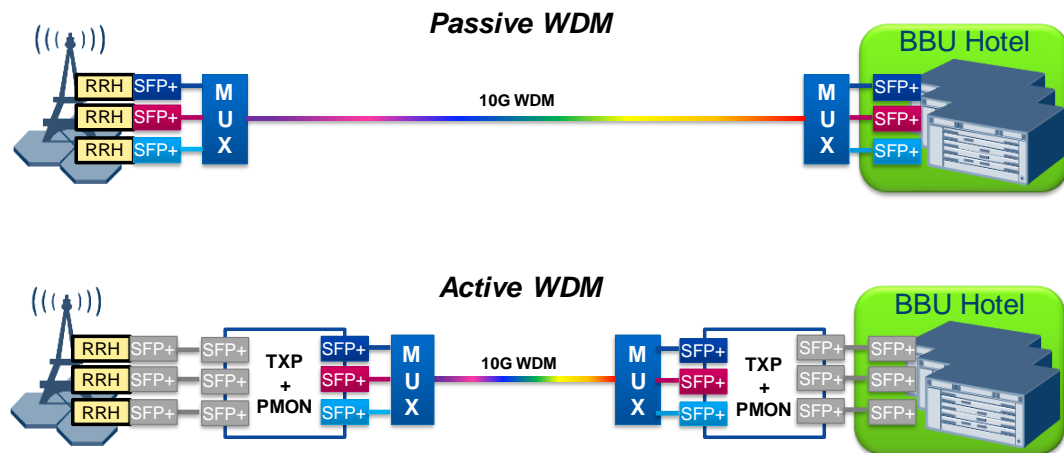

In passive WDM, the WDM optical modules are plugged directly into the RRH and the BBU. The advantage of passive WDM systems is that they do not require a power supply, and so can be placed directly on cell-site powers. They are commonly used where a mobile operator is building their own fronthaul network but lacks sufficient fiber to the BBU hotel site.

On the other hand, active WDM systems do require a power supply. They may be placed outdoors or in environmentally-controlled locations, such as a street-cabinet or aggregation site. Placing the system in an environmentally-controlled location increases the flexibility in the type of equipment that may be used, and eliminates the need for industrial temperature range WDM modules. Furthermore, active WDM systems tend to have more advanced OAM capabilities when compared with passive WDM, and can act as a demarcation point.

Both conventional passive and active WDM systems share a number of challenges, particularly as we consider the evolution to 5G.

- Limited Scalability—as the systems are limited to Nx10G wavelengths, they are essentially limited to carrying a single CPRI client per wavelength. Once the available wavelengths have been consumed, more fiber and more equipment must be deployed to handle the required capacity.
- Higher Power—WDM optical modules require higher power than grey optical modules. This can lead to incompatibility with existing RRHs, as well as higher OpEx.
- Complex Inventory Management—“fixed” WDM optical modules are typically used, meaning that each module is only capable of transmitting a particular wavelength. Because each wavelength must be unique for each CPRI client, the operator must maintain inventory for each of the WDM colors used. Furthermore, when a module fails, it is critical that it is replaced with

one of the same color. This can be problematic under any situation, let alone during outdoor tower climbs.

- Not 5G Ready—as discussed in Evolving to 5G, industry consensus is that 5G systems will require dense 10GE and 25GE. However, conventional WDM systems today are limited to 10G wavelengths.
- Lack Security—neither conventional passive nor active WDM systems provide any security capabilities into the fronthaul network and leave the baseband signal carrying mobile user traffic open to snooping and theft.

The following illustration provides summary of conventional passive and active WDM systems versus fronthaul requirements for the 4G and 5G era.

**Figure 8 Comparing Passive/Active WDM and Fronthaul Requirements**

|            | Requirement                              | Passive WDM                       | Active WDM |
|------------|--|-----------------------------------|------------|
| Timing     | Latency                                  | Negligible                        | < 5us      |
|            | 3GPP Frequency Error and EVM performance | Meets                             | Meets      |
|            | Latency Symmetry                         | Yes                               | Yes        |
| Networking | Switchable                               | No                                |            |
|            | WDM Uplink                               | Mandatory, limited to 10G maximum |            |
|            | CPRI 5, 6, 7                             | WDM only, 1 Wavelength per CPRI   |            |
|            | CPRI 10                                  | None                              |            |
|            | 10GE Support                             | WDM only, 1 Wavelength per 10GE   |            |
|            | 25GE Support                             | None                              |            |
|            | Demarcation                              | None                              | Yes        |
|            | Scalability                              | Limited to 10G                    |            |
|            | Link Security                            | None                              |            |

While conventional passive and active WDM systems have been successful in addressing mobile operators’ requirements for fronthaul in its early stages, it is clear that new solutions are required as operators add capacity and deploy 5G.

## 4 The Case for 100G OTN-Based Mobile Fronthaul

The evolution currently taking place in the mobile network to dense 10G CPRI interconnect, coupled with the need for Nx10G and Nx25G Ethernet, has many parallels with the evolution to today’s metro network. The following illustration highlights that as the services in the metro network evolved from T1/E1 to today’s multiservice network supporting GE, 10GE, SONET/SDH, video, and FC/SAN, the transport layer evolved from 10G SONET/SDH to 100G Optical Transport Network (OTN).

**Figure 9 Metro vs. Mobile Network Evolution**

|                           | Metro Networks |  | Mobile Networks |                           |
|---------------------------|----------------|--|-----------------|---------------------------|
|                           | “Legacy”       | Today                                    | “Legacy”        | Evolved                   |
| <b>Client Services</b>    | T1/E1          | Ethernet<br>SONET/SDH<br>Video<br>FC/SAN | CPRI            | CPRI,<br>Ethernet         |
| <b>Service Rates</b>      | 64k to 1M      | 1G to 10G                                | 622M to 2.5G    | 4.9G to Nx25G             |
| <b>Transport Solution</b> | 10G SONET/SDH  | 100G OTN                                 | 10G WDM         | <b>Industry Challenge</b> |

The ITU-T’s G.709 OTN standard enables a single transport layer that simultaneously supports multiple client services and rates coupled with carrier-grade OAM. 100G OTN allows up to 100G of multiservice clients to be multiplexed into the same 100G container (OTU4), allowing up to 10x more data to flow across the same fiber infrastructure. Furthermore, as volume ramps, the ecosystem is continuing to drive cost out, allowing 100G OTN to provide substantial cost/bit savings relative to Nx10G WDM. As a result, 100G OTN has become the dominant transport layer used in service provider metro networks worldwide. The same characteristics that drive 100G transport in the metro is also what mobile networks require as they evolve to LTE-A and 5G.

### 4.1 100G OTN vs. Conventional WDM for Fronthaul

Let’s assume a network is composed of the following radio components:

- 3x 4G sectors each supplied by one CPRI option 7 at 9.8 Gbps
- 2x 5G sectors each supplied by one 25GE
- 1x 5G sector supplied by one 10GE

A conventional active WDM solution for this network is shown in the following illustration.

**Figure 10 Conventional WDM Solution for Converged 4G and 5G Fronthaul**

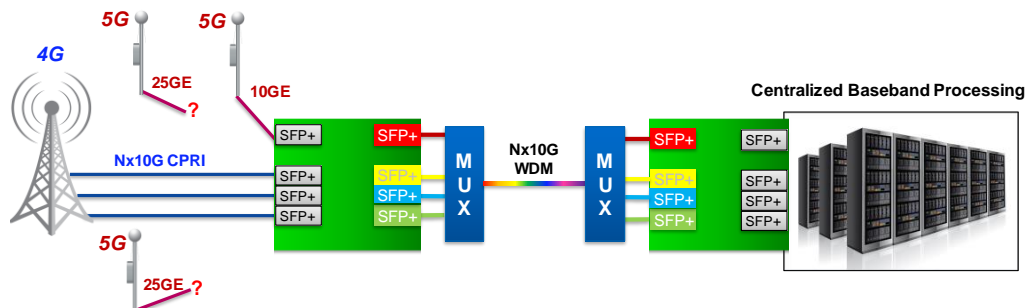

Two issues immediately become apparent. First, the solution requires multiple 10G WDM modules, two per signal transported. As the next section will show, this has a significant impact on the optical transceiver cost for the network. Secondly, and perhaps more importantly, because of a lack of available 25G WDM optical modules, the 25GE-based 5G radios are left without a viable fronthaul solution.

The following illustration shows a 100G OTN based solution for the same scenario.

**Figure 11 100G OTN Solution for Converged 4G and 5G Fronthaul**

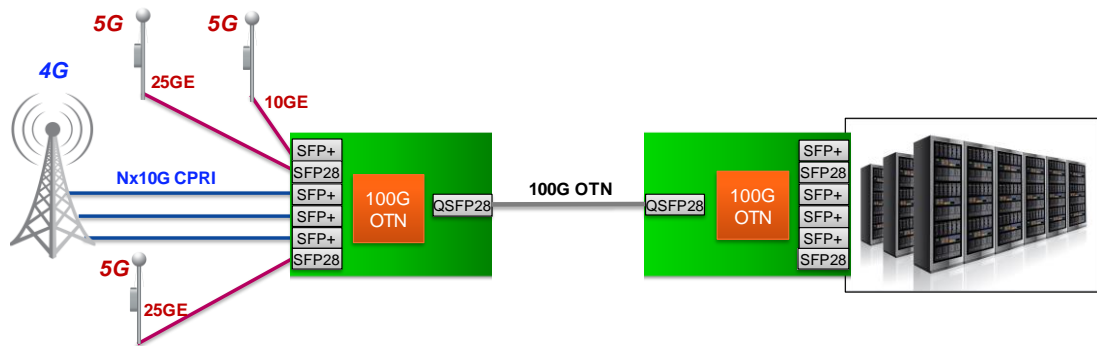

100G OTN provides numerous advantages in the fronthaul network as a solution for the convergence of 4G and 5G.

- Fully Converged 4G and 5G Fronthaul—CPRI and Ethernet clients totaling up to 100G can be multiplexed into a single 100G OTN container. Furthermore, client rates are no longer limited to 10G, allowing for the support of 25GE and beyond.
- CapEx and OpEx Reduction—the requirement for WDM optical modules is eliminated, enabling the use of lower cost and lower power grey modules throughout, simplifying inventory management. In addition, standard OTN Forward Error Correction (FEC) not only helps reduce bit errors in the network, but it extends the 10 km reach of low-cost 100GBASE-LR4 optical modules to up to 20 km or more.
- Scalability—if fronthaul capacity scales beyond 100G, 100G OTN may be combined in the long term with emerging low-cost and low-power 100G WDM modules to maximize fiber capacity, allowing for >10x the capacity of conventional fronthaul solutions.
- Carrier-Grade OAM—by virtue of its pedigree in metro networks, OTN provides a substantially more robust set of OAM features, including forward and backward path monitoring, bit error monitoring for fault isolation, and standardized consequential actions.
- Robust Ecosystem—100G OTN is enabled by a broad ecosystem of optical equipment and component vendors. As it is the standard metro network transport layer, it is also compatible with existing transport network management systems, including those offering next-generation Software Defined Networking (SDN) capabilities.

## 4.2 Economics of 100G OTN vs. Conventional WDM

With the technical advantages and rationale for 100G OTN firmly established, let's examine the economics of optical transceiver costs. As noted, the use of 100G OTN's FEC allows for the use of low-cost data center-style 100GBASE-LR4 optical transceivers in fronthaul networks. Although rated for 10 km, the net coding gain of the FEC helps extend the reach of the signal from 10 km to 20 km or more.

Using readily available market data, the average cost of QSFP28 optical transceivers is approximately \$1500 (USD) and 10G WDM SFP+ modules are approximately \$415. The following illustration plots the cost of the required optical transceivers for OTN and passive/active WDM systems as the number of CPRI to be fronthauled increases.

**Figure 12 Optical Transceiver Cost for 100G OTN and Conventional WDM Systems**

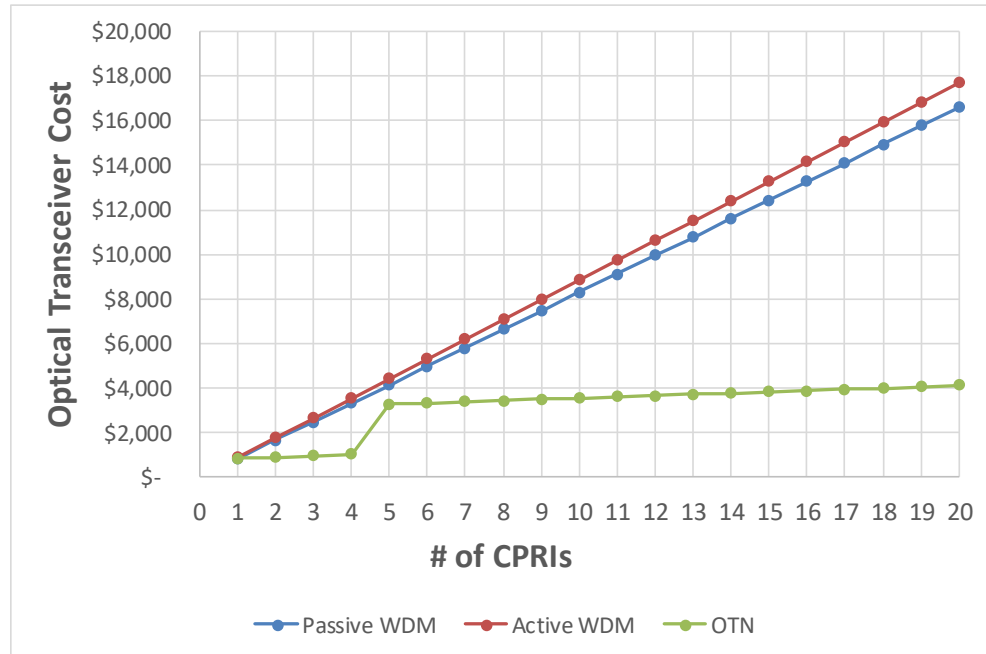

While optical transceiver costs continue to increase linearly for each additional CPRI or Ethernet signal to be transported in both passive and active WDM systems, optical transceiver cost is essentially flat for 100G OTN. This is due to the fact that 100G OTN can carry up to 20x CPRI option 5 or 10x CPRI option 7 for essentially the same cost as 5 CPRI. Transporting 20 CPRI option 5 signals using 100G OTN offers up to a 75% reduction in optical transceiver costs versus passive and active WDM. Likewise, transporting 10x CPRI 7 with 100G OTN offers up to a 50% reduction in optical transceiver costs.

### 4.3 Summary

100G OTN offers numerous technical advantages over passive and active WDM, including the ability to support scenarios (such as 25GE) that are not readily supportable with WDM today. Fore, 100G OTN offers substantial savings in optical transceivers coupled with enhanced scalability.

## 5 Microsemi’s Mobile Fronthaul Solution

The case for 100G OTN in fronthaul networks is clear:

- Unsurpassed fronthaul capacity
- Ability to support converged 4G and 5G radio networks
- Multi-service and multi-rate support
- Carrier-grade OAM
- Ability to leverage low-cost, low-power grey optics
- Substantial savings in optical transceiver costs relative to both passive and active WDM

However, CPRI imposes exceptionally challenging latency, jitter, and uplink/downlink delay accuracy requirements on the transport network. Microsemi’s groundbreaking DIGI-G4-based Mobile Fronthaul Solution has solved these challenges, enabling mobile operators to deploy a single fronthaul network that supports both 4G and 5G.

**Figure 13 Converged 4G and 5G Fronthaul Network Enabled by Microsemi**

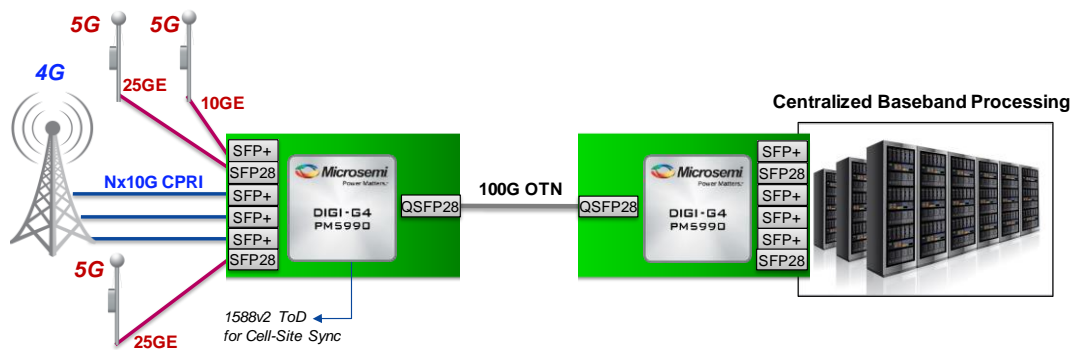

Microsemi’s solution allows up to 20x CPRI or Ethernet clients to be multiplexed into a single 100G OTU4. A second OTU4 port is also available and may be used to support a protection path or to support a path to a different baseband hotel site for flexible load balancing of baseband resources. Furthermore, a per-client security engine is integrated, providing AES-256 encryption at wire-speed coupled with authentication services for secure fronthaul networking.

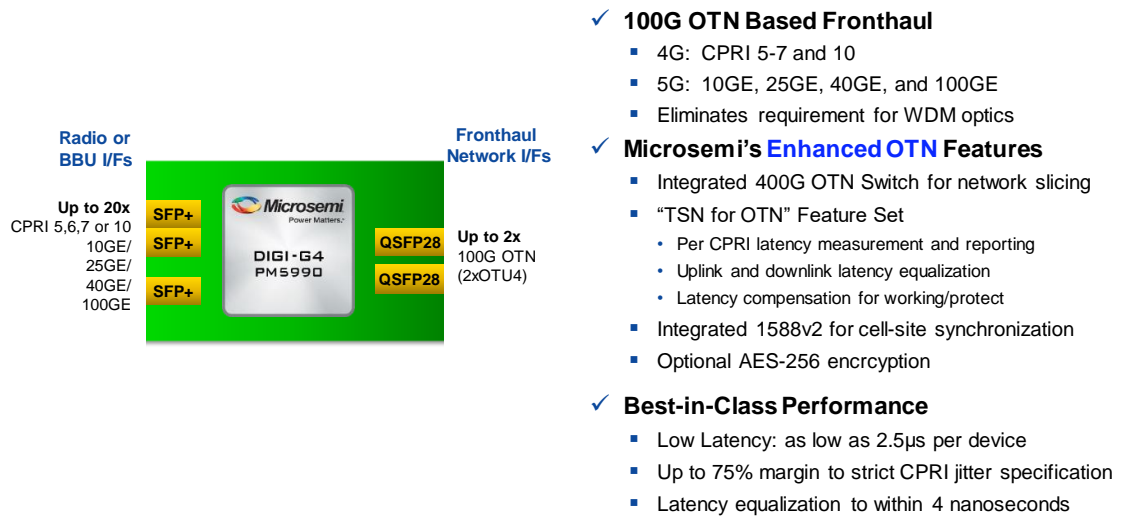
**Figure 14 Microsemi’s Groundbreaking DIGI-G4 Based Mobile Fronthaul Solution**

Not just any 100G OTN processor can support fronthaul. Microsemi’s DIGI-G4-based Mobile Fronthaul Solution is built upon a series of innovations that make 100G OTN fronthaul a reality.

## 5.1 Microsemi Innovations to Enable 4G and 5G Fronthaul

Microsemi’s DIGI-G4 Mobile Fronthaul Solution features the following critical innovations.

- Network Slicing Ready – supports mapping of any client or packet stream into individual ODUflex containers that are right-sized for the particular traffic flow. All ODUflex-enabled network slices support full carrier-grade OAM with optional tunnel encryption.
- Integrated 400G OTN Switch – enables switched based network architectures
- Per Port Ultra-Low Bandwidth Desynchronizer—each port is equipped with an on-board, ultra-low bandwidth de-synchronizer operating in the sub-Hz range. The result is the ability to easily meet the stringent CPRI jitter specification of 2 ppb, with typical results in the 0.5 ppb range for both synchronous and asynchronous CPRI clients.
- Per Link Latency Management, Equalization, and Compensation—key requirements for mobile fronthaul applications are the need for ultra-low latency in the fronthaul network. Furthermore, the uplink and downlink latencies must be symmetric in order to facilitate baseband unit processing. Microsemi’s Mobile Fronthaul Solution measures, reports, and if desired, equalizes the uplink and downlink latency on each CPRI client to within nanoseconds. The solution also supports link latency compensation, allowing latencies on different paths (for instance, in protection scenarios) to be equalized.
- Cell-Site Synchronization—Microsemi’s Mobile Fronthaul Solution provides IEEE 1588v2 synchronization including time-of-day (ToD) to each fronthaul node in the fronthaul network, a critical requirement as mobile fronthaul networks evolve to Ethernet-based links in the 5G era.
- Fronthaul Security—the need for encryption and authentication services continues to grow. The DIGI-G4 family supports AES-256 encryption coupled with authentication to enable wirespeed OTN security at either the high order OTU4 level or the per-client level.
- Field-Proven DIGI-G4 Hardware and Software—the DIGI-G4 Mobile Fronthaul Solution is built on field-proven hardware and software currently in use by network operators worldwide.



With these innovations in mind, a network slicing-enabled and switched mobile transport may be built as shown in the following figure.

**Figure 15 Network Slicing Enabled and Switched Mobile Transport Network**

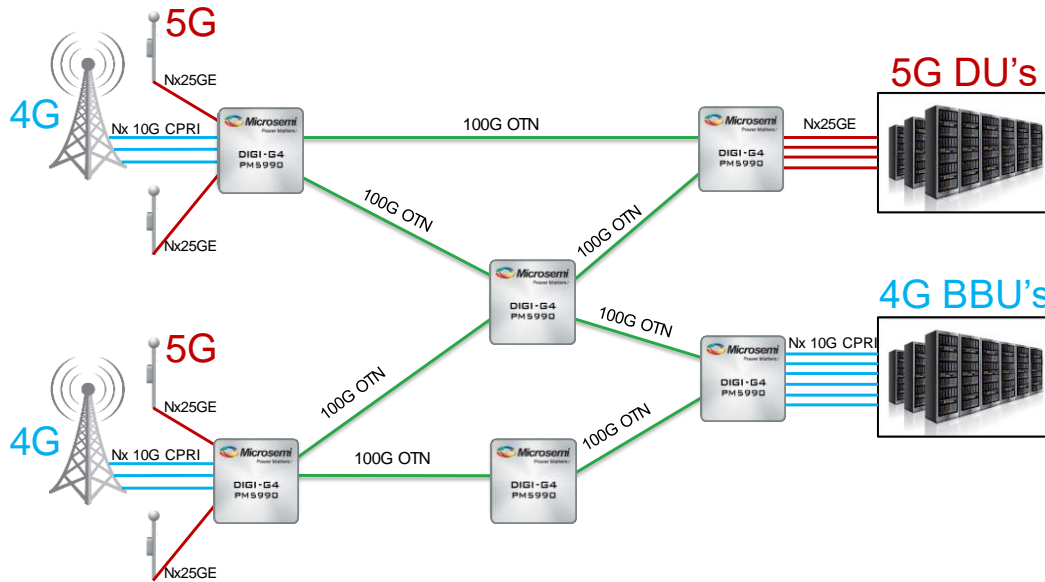

## 5.2 Summary of the DIGI-G4 Mobile Fronthaul Solution

The following table summarizes how Microsemi’s DIGI-G4 Mobile Fronthaul Solution addresses the challenging timing requirements associated with CPRI, and provides a solution that uniquely addresses the networking requirements of a converged 4G and 5G network.

**Figure 16 DIGI-G4-based 100G OTN Fronthaul vs. Conventional WDM Solutions**

|            | Requirement                              | Passive WDM                       | Active WDM |  |
|------------|--|-----------------------------------|------------|---|
| Timing     | Latency                                  | Negligible                        | < 5us      | < 2.5µs per device  |
|            | 3GPP Frequency Error and EVM performance | Meets                             | Meets      | Meets   |
|            | Latency Symmetry                         | Yes                               | Yes        | Yes – with ability to measure and equalize  |
| Networking | Switchable                               | No                                |            | Yes   |
|            | WDM Uplink                               | Mandatory, limited to 10G maximum |            | Optional  |
|            | CPRI 5, 6, 7                             | WDM only, 1 Wavelength per CPRI   |            | Up to 20x per 100G  |
|            | CPRI 10                                  | None                              |            | Up to 4x per 100G   |
|            | 10GE Support                             | WDM only, 1 Wavelength per 10GE   |            | Up to 10x per 100G  |
|            | 25GE Support                             | None                              |            | Up to 4x per 100G   |
|            | Demarcation                              | None                              | Yes        | Yes   |
|            | Scalability                              | Limited to 10G                    |            | Highest: 100G+  |
|            | Link Security                            | None                              |            | AES-256 encryption + authentication   |

## 6 Conclusion

---

To address the explosive growth in mobile data, mobile operators are adding capacity and evolving to the C-RAN architecture in preparation for 5G. With 5G on the horizon, the need for a high-capacity, low-latency, cost-effective, and scalable fronthaul solution has never been greater. While conventional WDM fronthaul solutions are available, they often lack the scale needed for today's 4G networks while suffering further incompatibility with future Ethernet-based 5G networks.

100G OTN addresses the needs for a truly converged 4G and 5G fronthaul network, but is still challenged by the need to meet stringent CPRI latency and jitter constraints.

Microsemi's DIGI-G4-based Mobile Fronthaul Solution introduces a groundbreaking series of innovations to the equation to address the most challenging aspects of fronthaul. The solution offers the following benefits to mobile operators and OEMs.

### **Converged 4G and 5G Fronthaul**

- Enables simultaneous supports for up to 20x CPRI and Ethernet clients
- Provides 2 x 100G fronthaul uplinks with an optional link security engine

### **Reduced CapEx and OpEx for Mobile Operators**

- Enables use of low-cost 100GBASE-LR4 optics, providing up to 75% savings on optics
- Simplifies inventory management by eliminating the need for WDM optics

### **Simplifies Fronthaul Network Deployment**

- Uplink and downlink latency measurement and equalization
- Multi-path latency compensation for protection or baseband load balancing scenarios

### **Lowest Risk and Fastest Time to Market for OEMs**

- Built on Microsemi's production-released and field-proven DIGI family platform
- Enables simple and low-cost upgrade of existing cards to address the fronthaul opportunity presented by the evolution towards 5G

With Microsemi, cost-effective, scalable, and future-proof 100G OTN fronthaul is now a reality.

## 7 References

---

1. Ericsson Mobility Report, November 2016  
<https://www.ericsson.com/assets/local/mobility-report/documents/2016/ericsson-mobility-report-november-2016.pdf>
2. IHS Markit report: C-RAN Architecture Equipment Market Report – Regional - 2016  
<https://technology.ihs.com/572317/c-ran-architecture-equipment-market-report-regional-2016>



Microsemi Corporate Headquarters  
One Enterprise, Aliso Viejo, CA 92656 USA  
Within the USA: +1 (800) 713-4113  
Outside the USA: +1 (949) 380-6100  
Fax: +1 (949) 215-4996  
Email: [sales.support@microsemi.com](mailto:sales.support@microsemi.com)  
[www.microsemi.com](http://www.microsemi.com)

©2017 Microsemi Corporation. All rights reserved. Microsemi and the Microsemi logo are registered trademarks of Microsemi Corporation. All other trademarks and service marks are the property of their respective owners. The technology discussed in this document may be protected by one or more patent grants.

Microsemi Corporation (Nasdaq: MSCC) offers a comprehensive portfolio of semiconductor and system solutions for aerospace & defense, communications, data center and industrial markets. Products include high-performance and radiation-hardened analog mixed-signal integrated circuits, FPGAs, SoCs and ASICs; power management products; timing and synchronization devices and precise time solutions, setting the world's standard for time; voice processing devices; RF solutions; discrete components; enterprise storage and communication solutions; security technologies and scalable anti-tamper products; Ethernet solutions; Power-over-Ethernet ICs and midspans; as well as custom design capabilities and services. Microsemi is headquartered in Aliso Viejo, California, and has approximately 4,800 employees globally. Learn more at [www.microsemi.com](http://www.microsemi.com).

Microsemi makes no warranty, representation, or guarantee regarding the information contained herein or the suitability of its products and services for any particular purpose, nor does Microsemi assume any liability whatsoever arising out of the application or use of any product or circuit. The products sold hereunder and any other products sold by Microsemi have been subject to limited testing and should not be used in conjunction with mission-critical equipment or applications. Any performance specifications are believed to be reliable but are not verified, and Buyer must conduct and complete all performance and other testing of the products, alone and together with, or installed in, any end-products. Buyer shall not rely on any data and performance specifications or parameters provided by Microsemi. It is the Buyer's responsibility to independently determine suitability of any products and to test and verify the same. The information provided by Microsemi hereunder is provided "as is, where is" and with all faults, and the entire risk associated with such information is entirely with the Buyer. Microsemi does not grant, explicitly or implicitly, to any party any patent rights, licenses, or any other IP rights, whether with regard to such information itself or anything described by such information. Information provided in this document is proprietary to Microsemi, and Microsemi reserves the right to make any changes to the information in this document or to any products and services at any time without notice.