

THE CORVUS SERVICE MANUAL

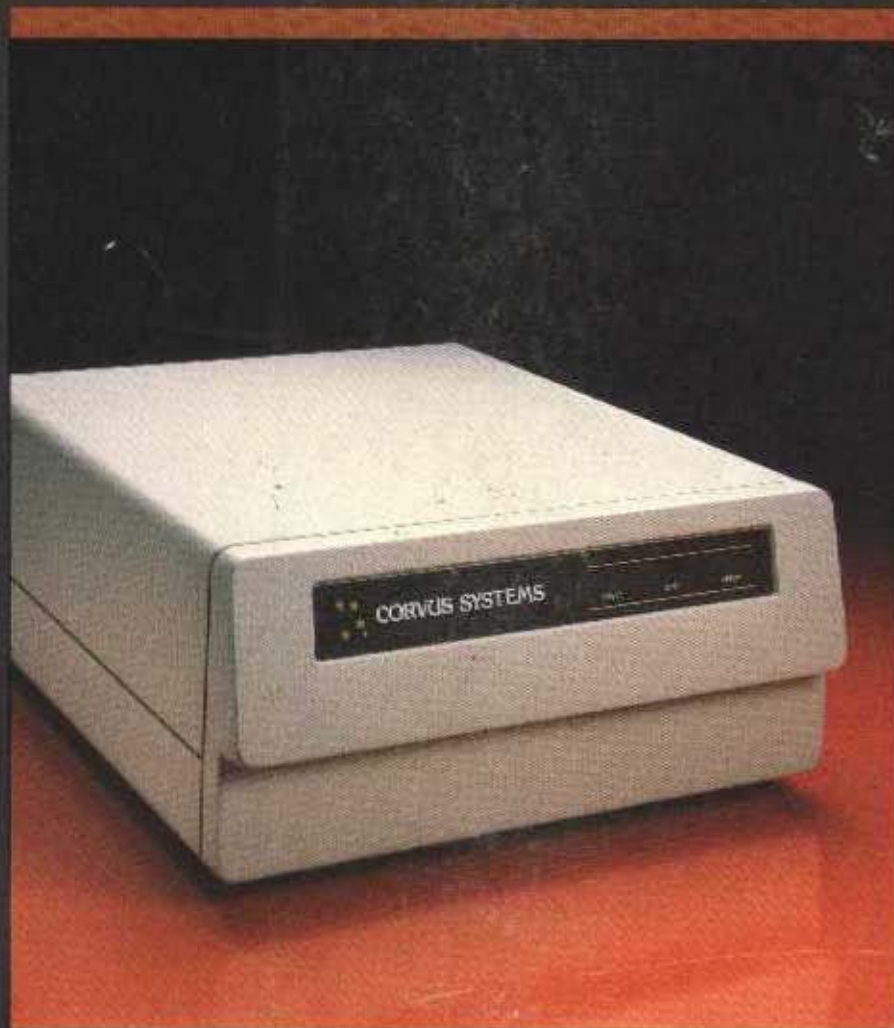

6 Megabyte Drive

CORVUS SYSTEMS

DISCLAIMER OF ALL WARRANTIES & LIABILITIES

Corvus Systems, Inc. makes no warranties, either expressed or implied, with respect to this manual or with respect to the software described in this manual, its quality, performance, merchantability, or fitness for any particular purpose. Corvus Systems, Inc. software is sold or licensed "as is." The entire risk as to its quality or performance is with the buyer and not Corvus Systems, Inc., its distributor, or its retailer. The buyer assumes the entire cost of all necessary servicing, repair, or correction and any incidental or consequential damages. In no event will Corvus Systems, Inc. be liable for direct, indirect, incidental or consequential damages, even if Corvus Systems, Inc. has been advised of the possibility of such damages. Some states do not consequential damages, so the above limitation may not apply to you.

Every effort has been made to insure that this manual accurately documents the operation and servicing of Corvus products. However, due to the ongoing modification and update of the software along with future products, Corvus Systems, Inc. cannot guarantee the accuracy of printed material after the date of publication, nor can Corvus Systems, Inc. accept responsibility for errors or omissions.

NOTICE

Corvus Systems, Inc. reserves the right to make changes in the product described in this manual at any time without notice. Revised manuals and update sheets will be published as needed and may be purchased by writing to:

Corvus Systems, Inc.
2029 O'Toole Avenue
San Jose, CA 95131
Telephone: (408) 946-7700
TWX 910-338-0226

This manual is copyrighted and contains proprietary information. All rights reserved. This document may not, in whole or in part be copied, photocopied, reproduced, translated or reduced to any electronic medium or machine readable form without prior consent, in writing, from Corvus Systems, Inc.

Copyright© 1982 by Corvus Systems, Inc. All rights reserved.

Mirror® patent pending, The Corvus Concept,™ Transporter,™ Corvus OMNINET,™ Corvus Logicalc,™ Time Travel Editing,™ EdWord,™ Constellation,™ Corvus,™ Corvus Systems,™ Personal Workstation,™ Tap Box,™ Passive Tap Box,™ Active Junction Box,™ Omninet Unit™ are trademarks of Corvus Systems, Inc.

FCC WARNING

This equipment generates, uses, and can radiate radio frequency energy and if not installed and used in accordance with the instruction manual, may cause interference to radio communications. As temporarily permitted by regulation it has not been tested for compliance with the limits for Class A computing devices pursuant to Subpart J of Part 15 of FCC Rules, which are designed to provide reasonable protection against such interference. Operation of this equipment in a residential area is likely to cause interference in which case the user at his own expense will be required to take whatever measures may be required to correct the interference.

CORVUS SYSTEMS
B-SERIES 5.25-INCH
6-MEGABYTE
WINCHESTER DISK DRIVE
SERVICE MANUAL

COVERING
REVISION A THROUGH REVISION E

PART NO.: 7100-04703
PUBLICATION NO.: GEN/10.2-01/1.1
RELEASE DATE: JUNE 15, 1983

This document contains three types of notations. These are, in increasing order of importance, **NOTE**, **CAUTION**, and **WARNING**. The **NOTE** indicates some action to be taken to speed or simplify a procedure. The **CAUTION** indicates that potential damage to the equipment or user data exists, and care should be taken to avoid this. The **WARNING** indicates that potential harm or injury to the service technician or operator exists, and extreme care should be taken to avoid these.

CORVUS DEALER SERVICE

TABLE OF CONTENTS

TABLE OF CONTENTS

List of Figures and Tables	v
List of Assembly and Schematic Drawings	vi
Specifications	vii

CHAPTER 1 — GENERAL DESCRIPTION

1.1	Scope of Chapter	1
1.2	Introduction	1
1.3	Purpose of Equipment	1
1.4	Model Identification	1
1.5	Corvus Disk System	3
1.5.1	Power Supplies	3
1.5.2	Data Backup	3
1.6	Winchester Disk Drive	5

CHAPTER 2 — INSTALLATION

2.1	Scope of Chapter	6
2.2	Introduction	6
2.3	Receiving a Drive	6
2.3.1	Diagnostic Test	6
2.4	Environmental Considerations	9
2.5	Daisy-Chaining of Disk Drives	10

CHAPTER 3 — OPERATION

3.1	Scope of Chapter	13
3.2	Introduction	13
3.3	Controls	13
3.3.1	Front Bezel LEDs	13
3.3.2	Front Bezel Switches	13
3.4	Power-On Sequence	14
3.5	Environmental Requirements	14
3.5.1	Static Electricity	14
3.5.2	Line Noise	15
3.5.3	Temperature	15
3.6	Periodic Maintenance	15
3.6.1	Regular Checks	16

CHAPTER 4 — DRIVE DESCRIPTION

4.1	Scope of Chapter	17
4.2	Introduction	17
4.3	Drive Revisions	17
4.3.1	Revision A Drive	17
4.3.2	Revision B Drive	19
4.3.3	Revision C, D and E Drives	20
4.4	General Description	20
4.4.1	Disk Sealed Mechanism	21
4.4.2	Power Supply	22

CORVUS DEALER SERVICE

4.4.2.1	CP134 (Rev A)	22
4.4.2.2	HB5 (Rev A)	22
4.4.2.3	CP417 (Rev B-E)	22
4.4.3	dc Power Cables	22
4.4.3.1	Rev A dc Cables	22
4.4.3.2	Rev B-E dc Cables	22
4.5	Controller Firmware	22
4.6	Data Storage	22
4.7	Transportation Considerations	23
4.8	Theory of Operation	23
4.8.1	Power-Up	23
4.8.2	Controller PCA	23
4.8.2.1	Controller During Seek Command	24
4.8.2.2	Controller During Read and Write Commands	24
4.8.3	Backplane PCA	24
4.8.4	Paddleboard PCA	24
4.8.5	Interface PCA	25

CHAPTER 5 — DISASSEMBLY

5.1	Scope of Chapter	26
5.2	Introduction	26
5.2.1	Tools Required	26
5.3	Metal Package	26
5.3.1	Top Cover	26
5.3.2	Controller PCA	26
5.3.2.1	Rev A Drives	26
5.3.2.2	Rev B Drives	26
5.3.3	Backplane PCA	27
5.3.3.1	Rev A Drives	27
5.3.3.2	Rev B Drives	27
5.3.4	Drive Mechanism	27
5.3.5	Power Supplies	27
5.3.5.1	Rev A Drives	27
5.3.5.2	Rev B Drives	27
5.3.6	Front Bezel	27
5.4	Plastic Package	27
5.4.1	Top Cover	28
5.4.2	Controller PCA	28
5.4.3	Backplane PCA	28
5.4.4	Drive Mechanism	28
5.4.5	Power Supply	28
5.4.6	Front Bezel	28

CHAPTER 6 — ADJUSTMENTS AND MAINTENANCE

6.1	Scope of Chapter	29
6.2	Introduction	29
6.3	Power Supply Voltage Check and Adjustment	29
6.3.1	Rev A Drives - Dual Power Supplies	29

CORVUS DEALER SERVICE

6.3.1.1	Voltage Check (CP134)	29
6.3.1.2	Voltage Adjustment (CP134)	30
6.3.1.3	Voltage Check (HB5)	30
6.3.1.4	Voltage Adjustment (HB5)	30
6.3.2	Rev B Drives - Single Power Supply	32
6.3.2.1	Voltage Check (CP417)	32
6.3.2.2	Voltage Adjustment (CP417)	32

CHAPTER 7 — DEALER SERVICE DIAGNOSTICS

7.1	Scope of Chapter	33
7.2	Introduction	33
7.3	Drive Diagnostics	33
7.3.1	CRC	33
7.3.2	EXR	34
7.3.3	UPD	34
7.3.4	VSN	34
7.3.5	FMT	35
7.3.6	PRM	35
7.3.6.1	MUX	35
7.3.6.2	DRIVE	36
7.3.7	SET	36
7.3.8	QUIT	36
7.4	Controller Diagnostic	36
7.4.1	General Description	36
7.4.2	Controller Diagnostic Commands	37
7.4.2.1	A) Abort Diagnostic	37
7.4.2.2	B) Macro Menu	37
7.4.2.3	C) Change Slot Number	38
7.4.2.4	D) Download Diagnostic	38
7.4.2.5	I) Analyze Servo	38
7.4.2.6	J) Single Do Seek	38
7.4.2.7	L) Full Cylinder Loopseek	38
7.4.2.8	P) Print Quiet Summary Report	38
7.4.2.9	Q) Sector Quiet Program	39
7.4.2.10	S) Read Scan Disk	39
7.4.2.11	T) Single Cylinder Seek Scan	39
7.4.2.12	X) Write Scan Disk	40
7.4.2.13	Y) Rezero Heads	40
7.4.3	Error Codes	40
7.5	Burn-In Program	40
7.5.1	C)ONT	40
7.5.2	L)IST	41
7.5.3	R)ESTART	41
7.5.4	Q)UIT	41
7.6	Read Burn-In Results	41

CHAPTER 8 — FAULT ISOLATION PROCEDURES

8.1	Scope of Chapter	42
8.2	Introduction	42
8.3	Tools	42

CORVUS DEALER SERVICE

8.4	Error Codes	42
8.4.1	Interpreting Error Codes	42
8.5	Troubleshooting Procedures	46
8.5.1	On-Site Checks	46
8.5.2	Isolate the Problem	46
8.5.3	Drive Not Ready	47
8.5.3.1	Interface	47
8.5.3.2	Controller Firmware	47
8.5.3.3	Power Supply Voltages	47
8.5.3.4	Drive Electronics	47
8.5.3.5	Drive Sealed Mechanism	48
8.5.4	Link Inoperative	48
8.5.4.1	Check Link Action	48
8.5.4.2	Power Supply	48
8.5.4.3	CRC Test	48
8.5.4.4	Controller Communication	49
8.5.4.5	Servo Action	49
8.5.4.6	Controller Firmware	49
8.5.4.7	Boot ROM	49
8.5.4.8	Interface Components	49
8.5.4.9	Drive Initialization	49
8.6	Final Adjustments and Tests	50
8.6.1	CRC Test	50
8.6.2	Install and Test Mirror	50
8.6.3	CRC Test	50
8.6.4	Power Supply	50
8.6.5	Burn-In Test	50
Appendix A	Glossary	57
Appendix B	Parts List for B-Series 6MB Drives	59
Appendix C	B-Series 6-Megabyte Cabling Chart	60
Appendix D	Assembly and Schematic Drawings	61

LIST OF FIGURES AND TABLES

LIST OF FIGURES AND TABLES

Figures

Figure 1-1	B-Series 6-Megabyte Drive (Revisions C-E)	viii
Figure 1-2	B-Series 6-Megabyte Drive (Revision B)	2
Figure 1-3	B-Series 6-Megabyte Drive (Revision A)	4
Figure 2-1	MIRROR Switch Location	7
Figure 2-2	MIRROR Switch Settings	7
Figure 2-3	Rear Bezel	8
Figure 2-4	Disk Drive Installation	9
Figure 2-5	Controller Address Switch Location	10
Figure 2-6	Controller Address Switches	11
Figure 2-7	Daisy-Chaining of Disk Drives	12
Figure 3-1	Front Bezel Configuration Switches	14
Figure 3-2	Single-User Front Bezel Switch Positions	15
Figure 4-1	Disk Drive Sealed Mechanism	18
Figure 4-2	Data Configuration	19
Figure 4-3	Sector Interleaving	20
Figure 4-4	Disk Drive Contaminants	21
Figure 6-1	CP417 Power Supply	29
Figure 6-2	CP134 Power Supply	31
Figure 6-3	HB5 Power Supply	32

Tables

Table 8-1	Decimal Disk Error Codes	43
Table 8-2	Hexidecimal Disk Error Codes	44
Table 8-3	Signed Decimal Disk Error Codes	45

LIST OF ASSEMBLY AND SCHEMATIC DRAWINGS

LIST OF ASSEMBLY AND SCHEMATIC DRAWINGS

Final Assembly (Rev A Drive)	61
Final Assembly (Rev B Drive)	62
Final Assembly (Rev C-E Drives)	63
Drive Cover Assembly (Rev C-E Drives)	64
CORCOM Assembly (Rev C-E Drives)	65
CP134 Power Supply, Assembly (Rev A Drive)	66
CP134 Power Supply, Schematic (Rev A Drive)	67
HB5 Power Supply, Assembly and Schematic (Rev A Drive)	68
CP417 Power Supply, Assembly (Rev B-E Drives)	69
CP417 Power Supply, Schematic (Rev B-E Drives)	70
Read/Write PCA Phase 3, Schematic (Rev B-E Drives)	(1 of 4) 71
Read/Write PCA Phase 3, Schematic	(2 of 4) 72
Read/Write PCA Phase 3, Schematic	(3 of 4) 73
Read/Write PCA Phase 3, Schematic	(4 of 4) 74
Read/Write PCA Phase 3, Assembly	75
Controller PCA Phase 3, Schematic (Rev B-E Drives)	(1 of 6) 76
Controller PCA Phase 3, Schematic	(2 of 6) 77
Controller PCA Phase 3, Schematic	(3 of 6) 78
Controller PCA Phase 3, Schematic	(4 of 6) 79
Controller PCA Phase 3, Schematic	(5 of 6) 80
Controller PCA Phase 3, Schematic	(6 of 6) 81
Controller PCA Phase 3, Assembly	82
Read/Write PCA Phase 4, Schematic (Rev B-E Drives)	(1 of 4) 83
Read/Write PCA Phase 4, Schematic	(2 of 4) 84
Read/Write PCA Phase 4, Schematic	(3 of 4) 85
Read/Write PCA Phase 4, Schematic	(4 of 4) 86
Read/Write PCA Phase 4, Assembly	87
Controller PCA Phase 4, Schematic (Rev B-E Drives)	(1 of 6) 88
Controller PCA Phase 4, Schematic	(2 of 6) 89
Controller PCA Phase 4, Schematic	(3 of 6) 90
Controller PCA Phase 4, Schematic	(4 of 6) 91
Controller PCA Phase 4, Schematic	(5 of 6) 92
Controller PCA Phase 4, Schematic	(6 of 6) 93
Controller PCA Phase 4, Assembly	94
Read/Write PCA Phase 1, Schematic (Rev A Drives)	(1 of 3) 95
Read/Write PCA Phase 1, Schematic	(2 of 3) 96
Read/Write PCA Phase 1, Schematic	(3 of 3) 97
Read/Write PCA Phase 1, Assembly	98
Controller PCA Phase 1, Schematic (Rev A Drives)	(1 of 4) 99
Controller PCA Phase 1, Schematic	(2 of 4) 100
Controller PCA Phase 1, Schematic	(3 of 4) 101
Controller PCA Phase 1, Schematic	(4 of 4) 102
Controller PCA Phase 1, Assembly	103
Backplane PCA Schematic	104
Backplane PCA Assembly	105

CORVUS DEALER SERVICE

SPECIFICATIONS

CORVUS DEALER SERVICE

SPECIFICATIONS

Operational Specifications	Rev A	Rev B-E
Disks per Drive	2	2
Disk Diameter (in/mm)	5.25/133	5.25/133
Data Surfaces per Drive	4	4
Heads per Surface	1	1
Data Heads	4	4
Number of Data Cylinders/Drive	144	144
Sectors per Track	20	20
Track Density (TPI)	200	200
Bytes per Sector (Formatted)	512	512
Bytes per Track (Formatted)	10,240	10,240
Bytes per Drive (Formatted)	5.9MB	5.9MB
Bit Density, maximum (BPI)	8,800	8,800
Average Latency (ms)	N/A	6.25
Average Access Time (ms)	N/A	125
Maximum Access Time (ms)	N/A	240
Maximum Access Time, single-track (ms)	N/A	3
Data Transfer Rate (Kb/s)	960	960
Recording Format	MFM	MFM
Rotational Speed (RPM)	4,800	4,800
Start Time (s)	30	30
Stop Time (s)	15	15
Physical Dimensions	Rev A-B	Rev C-E
Height (in/cm)	5.25 / 13.3	5.75 / 14.6
Length (in/cm)	15.0 / 38.1	15.0 / 38.1
Width (in/cm)	14.5 / 36.8	12.0 / 30.5
Weight (lbs/kgs)		
Environmental Requirements		
Operating Temperature (F/C)	50° to 100° / 10° to 37°	
Non-Operating Temperature (F/C)	-40° to 140° / -40° to 60°	
Operating Relative Humidity (%)	10 to 80	
Non-Operating Relative Humidity (%)	10 to 90	
Operating Altitude (ft)	-1,000 to +10,000	
Operating Vibration (g)	0.1 (5 cps linear increase to 100 cps)	
Non-Operating Vibration (g)	1.0 (2 cps linear increase to 100 cps)	
Non-Operating Shock (g)	5.0 for 5ms duration	
Power Requirements		
Line Voltage, Domestic (VAC)	100-120, 48Hz-62Hz, Single-Phase	
Line Voltage, Foreign (VAC)	220-240, 48Hz-62Hz, Single-Phase	
	Rev A	Rev B-E
Power Consumption (Watts)	125	125
Line fuse (Amperes)		
for 100V-120V	3.0 slow-blow	2.0 slow-blow
for 220V-240V	1.5 slow-blow	1.0 slow-blow
Reliability		
Mean Time Between Failure (MTBF)	10,000+ operational hrs., within above requirements	
Maximum Repair Time	Not more than 0.5 hrs.	

CHAPTER 1
GENERAL DESCRIPTION

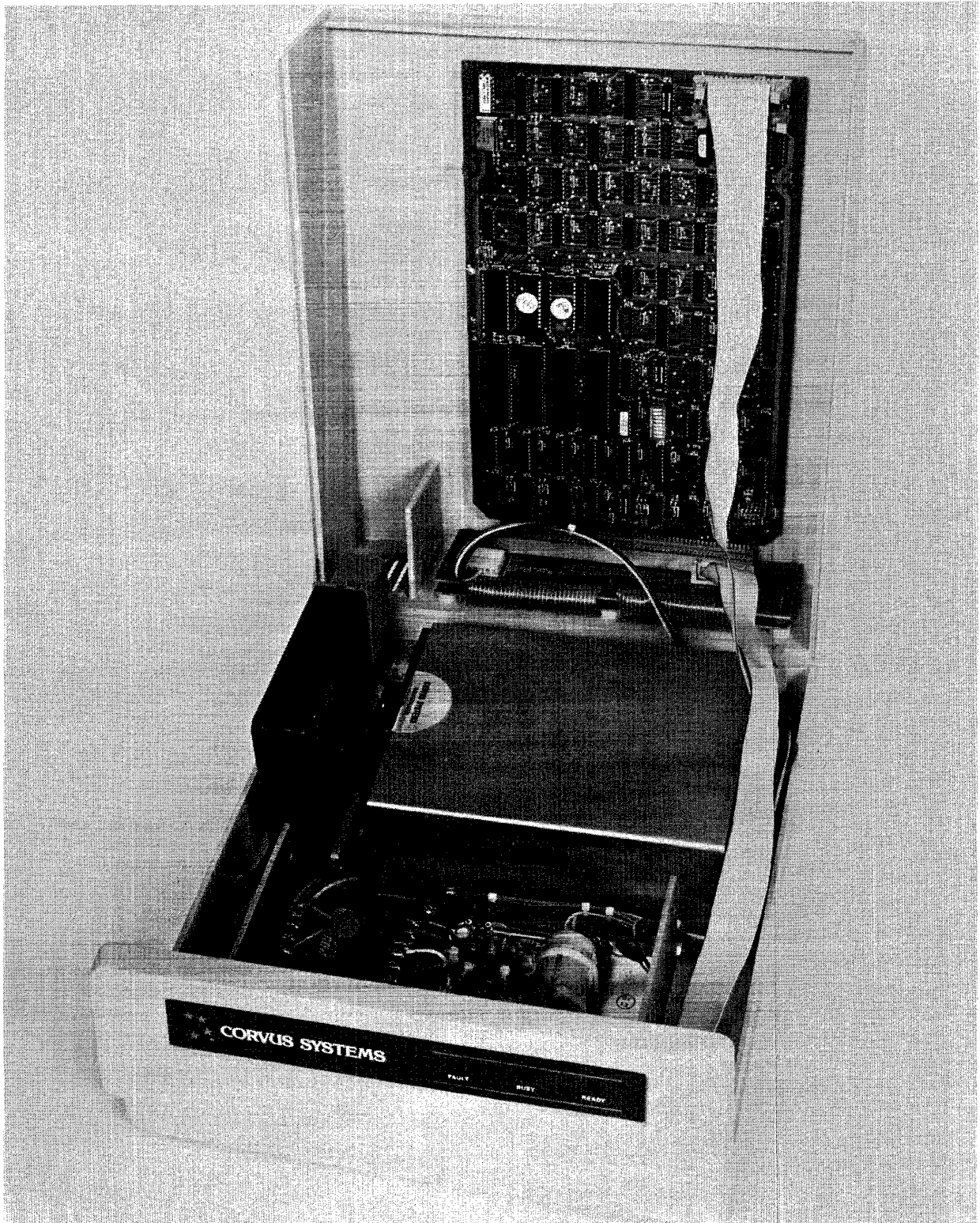

Figure 1-1. B-Series 6-Megabyte Drive (Revisions C-E)

CHAPTER 1 GENERAL DESCRIPTION

1.1 Scope of Chapter

This chapter outlines the purpose of the Corvus B-Series 6-Megabyte Disk Drives. A brief description and layout is included, as is a definition of Winchester technology.

1.2 Introduction

This document contains instructions for maintenance and repair of the Corvus Systems B-Series 6-Megabyte, 5.25-inch disk drive. Repair procedures for all 8-inch drives and 5.25-inch H-Series drives (Model 6, Model 11, and Model 20) are contained in separate service manuals. Repair procedures for networks and other Corvus equipment are covered in other Corvus service publications.

Corvus Disk Drive Product Line

A-Series Drives

- 8-Inch 11-Megabyte drive (Revision A)

B-Series Drives

- 8-Inch 11-Megabyte drive (Revision B)
- 8-Inch 20-Megabyte drive (Revision B)
- 5.25-Inch 6-Megabyte drives (All)

H-Series Drives

- 5.25-Inch 6-Megabyte drives (All)
- 5.25-Inch 12-Megabyte drives (All)
- 5.25-Inch 18-Megabyte drives (All)

Corvus Level I Dealer Service is on a module-replacement basis, and this manual is written to address this policy.

The B-Series 6-Megabyte drive has been manufactured in five revisions (A through E). These five drives were housed in one of two drive cabinets: the metal cabinet, and the high-impact, foam-injection plastic cabinet. Instructions for troubleshooting and repair for all of these drives are detailed in this document.

Also included in this manual is documentation for the Dealer Service Diagnostic Utilities supplied to each Corvus Servicing dealer. These utilities provide for burn-in/reliability testing, adjustment, and troubleshooting of all Corvus Disk Drives.

Installation and operation of the Disk Drive are not covered in detail in this manual. For instructions on installation and operation, see the Corvus "Disk Systems Installation Guide" and Corvus "Disk Systems User Guide."

1.3 Purpose of Equipment

The Corvus disk drive is a high-speed, intelligent mass-storage peripheral disk device designed to provide the host microcomputer with storage of digital information for instant retrieval at the request of the host system. The Corvus disk system consists of the 5.25-inch disk mechanism, a Z-80™ Intelligent Controller, power supply, host interface electronics, and may be ordered with 34-pin interface flatcable and Corvus Utility diskettes.

1.4 Model Identification

The Corvus 6-Megabyte disk drives may be broken down into two functional groups, each having different internal components within the cabinet. The first group consists of the Rev A drive, with the Rev B through Rev E drives making up the second group.

The Rev A and Rev B drives are packaged in the metal cabinet, while the Rev C drive uses a white plastic cabinet, and the Rev D and Rev E drives use a Concept-gray plastic cabinet. The drive type (capacity and revision) and manufacture date may be determined from the serial number tag.

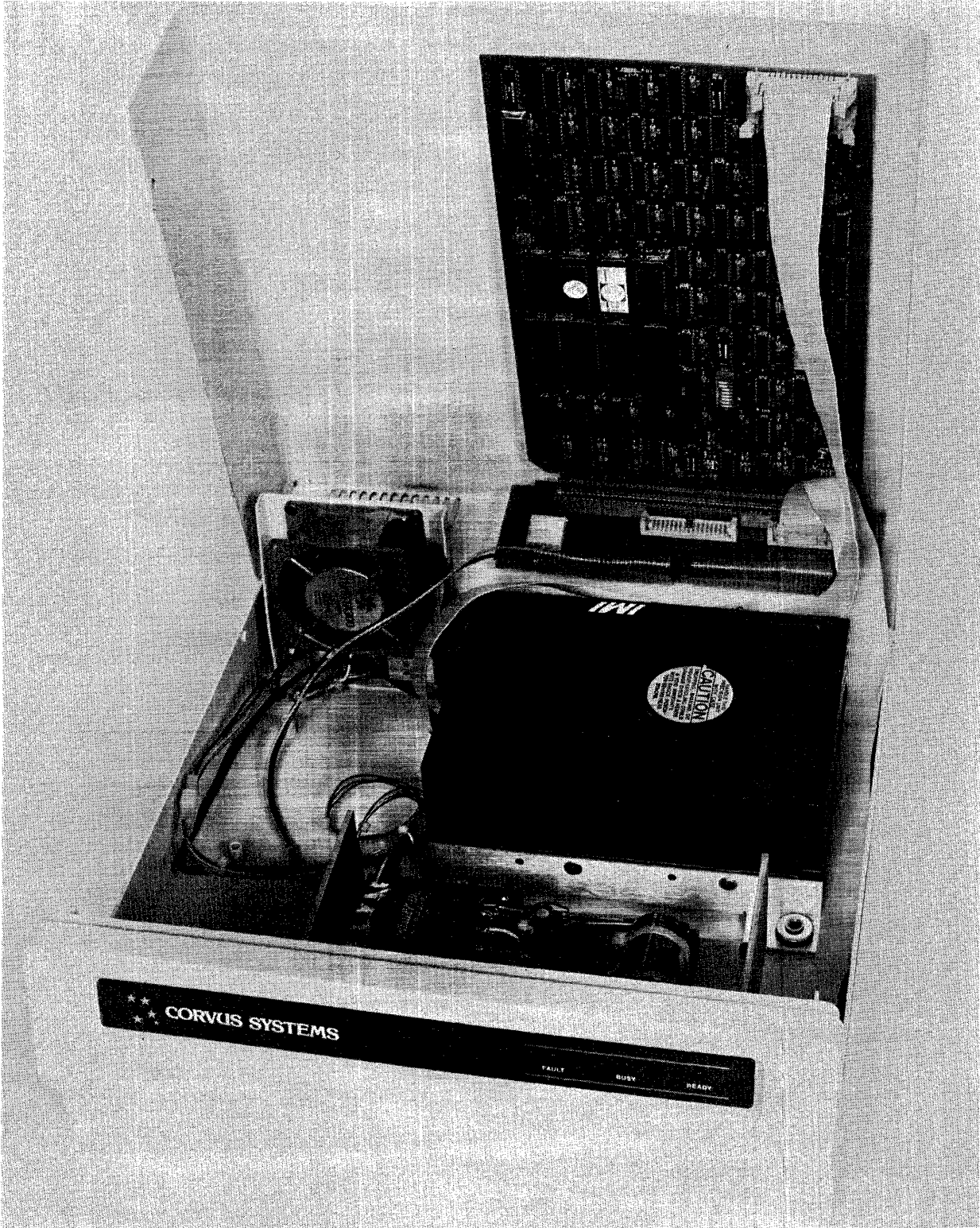

Figure 1-2. B-Series 6-Megabyte Drive (Revision B)

Locate the serial number tag at the rear of the drive basepan. The following is a sample serial number to be found on a Corvus 5.25-inch, 6-Megabyte drive:

142-A350/M

and is decoded below:

- 14 represents the week of manufacture (week 14)
- 2 represents the year of manufacture (2 for 1982)
- A represents the drive capacity (A=6MB)
- 350 represents the serial number of that drive
- /M represents that this drive was shipped with an internal Mirror installed

Whenever communicating with Corvus in reference to Corvus products, include the serial number of the equipment involved.

1.5 Corvus Disk Systems

The Corvus mass-storage disk system utilizes a sealed 5.25-inch Winchester disk mechanism manufactured by International Memories, Inc. (IMI)[™]. The drive, with its Intelligent Controller, is designed as a plug-in device, requiring minimal software setup. Interfacing to host computers is via 34-pin flat cable interface. Installation and setup procedures are covered in the corresponding "Disk System User Guide" for the appropriate computer system.

The Rev A drive consists of a 5.25-inch drive mechanism (with Read/Write PCA and Logic PCA), dual power supplies, Z-80 Controller PCA, and cooling fan mounted in the white metal cabinet. The later, Rev B drive consists of a different 5.25-inch drive mechanism (with Read/Write PCA), single power supply, Z-80 Controller PCA, and cooling fan mounted in the white metal cabinet. Rev C, Rev D and Rev E drives share these same components (as the Rev B), mounted in either a white (Rev C) or Concept-gray (Rev D and Rev E) cabinet.

Located in the bottom of the sealed unit is either one Read/Write PCA and one Logic PCA (Rev A drives) or one Read/Write PCA (Rev B through Rev E). These PC Assemblies are not field-serviceable items, and are not available as replacement parts. If the drive mechanism is diagnosed as defective, the entire drive sealed mechanism must be replaced.

The Mirror PCA (when installed) and the Z-80 intelligent Controller PCA are plugged into the two card slots of the backplane, inside the rear of the cabinet.

Although the Rev A and Rev B through Rev E drives are functionally identical (as far as the host microcomputer is concerned), no components are interchangeable, with the exception of the Mirror PCA.

1.5.1 Power Supplies

All 6-Megabyte drives operate from either 110-120VAC or 220-240VAC, 50Hz or 60Hz single-phase power. Rev A drives have two power supplies and the Rev B through Rev E drives have a single power supply. These two different power supply configurations are not interchangeable.

1.5.2 Data Backup

Data backup is accomplished via the Corvus MIRROR[™]. The Mirror converts the data from digital format to video format which is then stored on video cassette tape, using one of many commercial VCRs. The Corvus Mirror option comes internal to the drive when it is ordered, or added as an external device later. Mirror troubleshooting and repair is covered in the Corvus Mirror Service Manual.

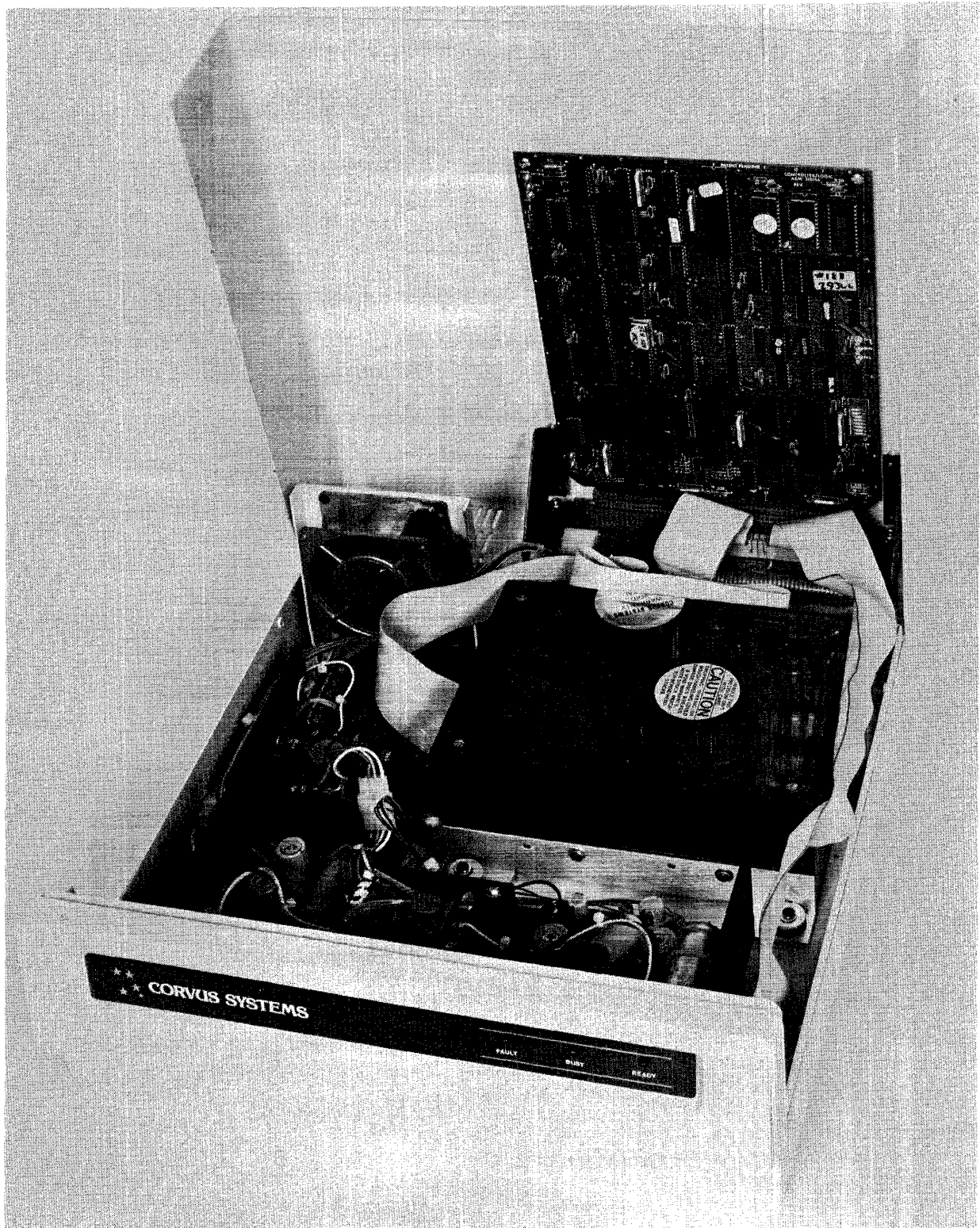

Figure 1-3. B-Series 6-Megabyte Drive (Revision A)

1.6 Winchester Disk Drive

The Corvus disk drive uses the International Memories Inc. (IMI) Winchester disk mechanism. This new generation of disk drive utilizes a sealed environment, and low-load, low-mass, aerodynamically-suspended read/write heads which rest directly on the disk surface after powerdown. It is the contaminant-free environment that allows for reduction in clearance between head and recording media. This results in the heads riding on an 18-microinch air bearing, or air cushion. Since bit density is closely related to head-media clearance and head mass, disk drives utilizing Winchester technology can achieve large storage capacities at a premium of space. An added advantage of the Winchester sealed mechanism is that it requires no regular maintenance.

[™]IMI is a registered trademark of International Memories Inc.

[™]Z-80 is a registered trademark of Zilog, Inc.

[™]Corvus MIRROR is a registered trademark of Corvus Systems, Inc.

CHAPTER 2
INSTALLATION

CHAPTER 2 INSTALLATION

2.1 Scope of Chapter

This chapter discusses installation of the disk drive hardware as it applies to environmental requirements, to insure proper operation. Installation and operation procedures for the Corvus disk system are outlined in the "Corvus Disk Systems Installation Guide" and "Corvus Disk Systems User Guide."

2.2 Introduction

Upon receipt, each drive should be checked for shipping damage, and tested for proper function. This chapter contains these check-out procedures as well as those for installing single- and multiple-drive systems.

2.3 Receiving a Drive

Any time a drive is received, several checks should be performed before the drive is installed at the customer site. Each Corvus disk drive should be carefully unpacked and checked for shipping damage. External evidence of rough handling may be symptomatic of damage to fragile mechanisms within the drive.

NOTE:

Any damage claims must be reported to the local office of the shipper so an inspection may be made, and a damage report filed. If the damaged equipment is a new product, Corvus Order Processing Department must be contacted for proper return procedures. If the damaged equipment is a recently serviced product being returned under an RMA number (Return Merchandise Authorization number), contact Corvus Customer Service Department for proper return procedures.

The disk drive mechanism in the Corvus Disk System is an extremely sensitive device. Subjecting the drive to a one-g force (one gravity) will be amplified and transmitted to the heads, impacting them onto the platter with a 100-g force. This necessitates very careful handling of the drive mechanism both in shipping and operation.

When a drive is received, check that all chips in the Z-80 Controller PCA are seated well in their sockets. Chips coming loose during shipping account for a large number of failures upon receipt.

- 1) Remove the screws securing the cabinet cover to the drive basepan (four on Rev A and B drives, two on Rev C, D and E drives), and remove the cover. Be careful not to stress the dc power cable and flatcables connecting the two halves of the drive cabinet.
- 2) Locate the Mirror PCA (if installed) plugged into the lower of the two card slots of the backplane, and remove it.
- 3) Locate the Controller PCA installed behind the Mirror PCA, and press firmly on all socketed chips, seating them securely into their sockets.
- 4) Replace the Mirror PCA.
- 5) Replace the drive cover and secure it with screws.

2.3.1 Diagnostic Test

When a disk drive is received, its proper function must be verified. The following list of procedures provides a means of accomplishing this.

- 1) Verify the front bezel switch positions.
- 2) Verify the Mirror switch positions (on the rear of the drive).
- 3) Check Controller Firmware VERSION.
- 4) Check the power supply voltages.
- 5) Execute the CRC Test.

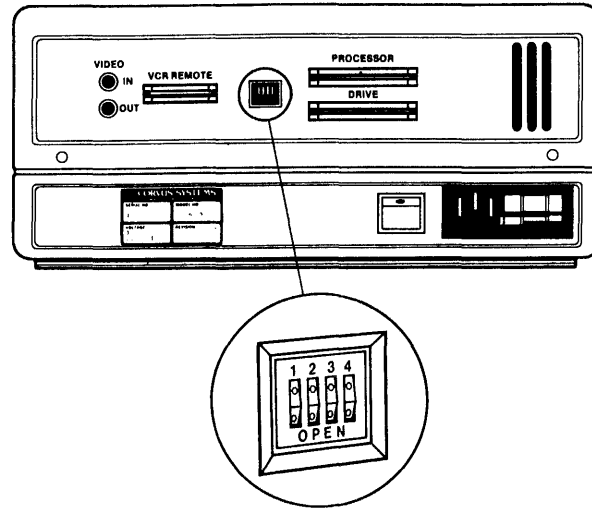
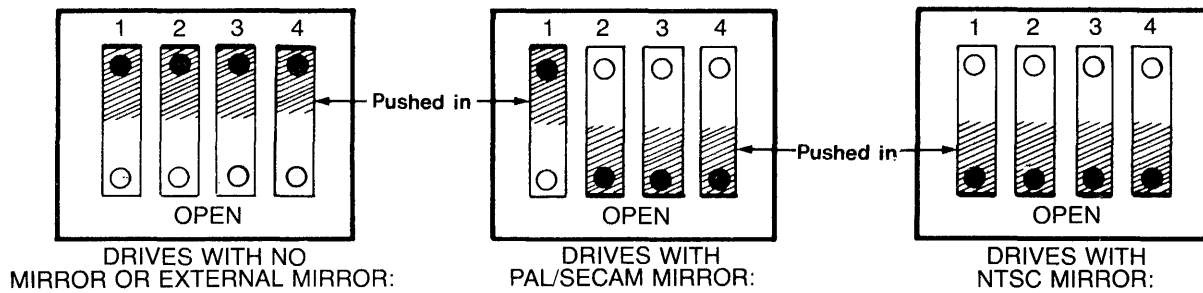

Figure 2-1. Mirror Switch Location



Shading indicates that the switch should be pushed in on that side.

Figure 2-2. Mirror Switch Settings

- 6) Check the parameters (DRIVE and MUX) and record on paper.
- 7) Execute the EXERCISE utility.
- 8) Run the BURN-IN Diagnostic (this is DESTRUCTIVE to data on the drive).
- 9) Update the Controller Firmware (Drive Diagnostic option UPD) changing the parameter tables when prompted (answer "YES").

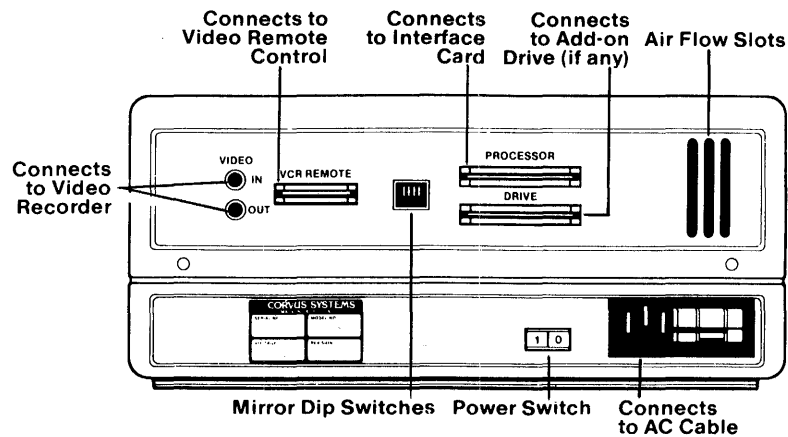

Figure 2-3. Rear Bezel

Any Corvus Disk Drive may be ordered with a Corvus Mirror PCA installed. In the 5.25-inch drive, the Mirror PCA plugs into the Backplane PCA alongside the Controller PCA, inside the cabinet cover. The drive has four DIP switches, located on the rear panel, which **MUST** be set to correctly reflect the internal Mirror configuration (whether installed or not). If these switches are not set correctly, the drive may not function properly (refer to the chart above for proper switch configuration). Drives using an external, or "Stand-Alone," Mirror should use the "No Mirror Installed" switch combination.

Check the drive power supply voltages and adjust if necessary (refer to Chapter 6, "Adjustments and Maintenance" for details).

Next, thoroughly test the drive, using the Dealer Service Diagnostics (as outlined in Chapter 7 "Diagnostics" of this manual). Execute a CRC-Format Check as well as verify the Drive Parameters (specifically the Spare Track Table and the Virtual Drive Offset Table). If either of these tables display values out of range, use the PARAMETERS diagnostic utility to reset them to their appropriate values.

A new drive may be shipped with up to four tracks spared. There are a total of seven spare tracks available, which leaves a minimum of three (and most likely more) for use in the field. When the Drive Parameters are first checked, the values should be noted, recorded on a label, and attached to the drive for future reference.

In the event that the drive format is disturbed in shipment, it may be necessary to reformat the drive. The FORMAT utility should be used only as a last resort. Using the PARAMETERS diagnostic utility, first try to restore the drive parameters before attempting the FORMAT utility. The FORMAT program will restore default parameters to the drive, and therefore necessitate re-initialization of these parameters with the original values (i.e. previously spared tracks).

Default parameters are:

Spare Track table: no tracks spared

VDO table: Drive 1 = 0

Interleave Spec: all 5.25-inch, B-Series drives = 12

Be sure to check the drive parameters before and after formatting the drive. If the drive has ever had a track spared, the Spare Track table and VDO table may need reconstruction before the data is restored. Knowing which tracks are spared prior to formatting the drive will simplify this procedure. Note on the label, any future tracks spared.

2.4 Environmental Considerations

All electronic equipment needs cooling and the Corvus drive is no exception. When installing, do not "pigeon-hole" the drive. There should be sufficient open air both front and rear. Place the drive on a level, hard surface without foam or carpeting; the air intake slots are on the bottom of the cabinet, and must not be restricted. Do not place a video monitor on top of, or near the Corvus drive. Electromagnetic fields generated by this device may cause drive malfunction.

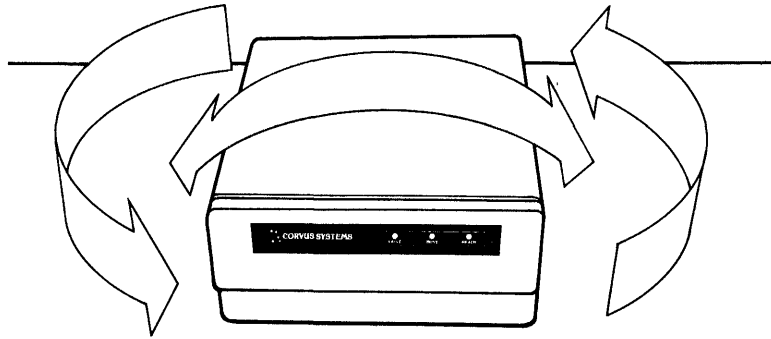

Figure 2-4. Disk Drive Installation (Allow Ample Room Around the Drive Cabinet)

Be sure the proper line voltage has been selected and proper fuse size is installed.

Insure the interface cable is properly connected between the connector on the interface card in the host computer, and the PROCESSOR connector on the rear bezel of the Corvus disk drive cabinet. Be sure the "one" edge (edge with dark stripe) is to the right, when facing the rear of the drive unit.

Check that all four front panel switches are in the correct position. Run your finger along from right to left, under the switches. All switches should be to the left, unless the disk drive is connected to a Corvus Multiplexer Network system, or to a DEC LSI-11™ computer. In this case, the appropriate switches should be set.

Locate the power switch on the rear of the drive, and turn it on. The drive motor will begin to spin, and all LEDs (front bezel Light Emitting Diodes) will come on, and the Busy LED will flash regularly. After approximately thirty seconds, the FAULT LED will go out, and the heads will rezero. LED activity will briefly alternate between READY and BUSY, after which the drive will set the READY signal, and all LED activity will cease, with the READY LED on. The disk drive is now ready for communication with the host system.

2.5 Daisy-Chaining of Disk Drives

A maximum of four physical Corvus disk drives can be interfaced to the host computer. This is accomplished by using a common input/output interface bus, commonly referred to as daisy-chaining. A maximum of 80 megabytes of on-line storage may be achieved by daisy-chaining four Model 20 drives. A special Corvus add-on drive flatcable is available specifically for this purpose. One add-on drive cable is required for each additional disk drive in the system.

All series and versions of disk drives may be daisy-chained together with the exception of the Rev A, 8-inch 11MB disk drive (Rev A drives may be daisy-chained only to other Rev A drives). When connecting H-Series drives in a daisy-chain, use controller firmware version CF18.3 (or newer) on all drives.

Changing the unit-select switches (positions 1-3) on the drive Z-80 Controller PCA for each add-on drive is required when daisy-chaining drives. New drives are shipped with the switches configured as drive 1. Additional drives should be set according to their position in the daisy-chain (2 through 7). Refer to the Corvus "Disk System User Guide" for the appropriate computer system.

For complete installation and initialization procedures, refer to the appropriate Corvus "Disk System Installation Guide" and "Disk System User Guide."

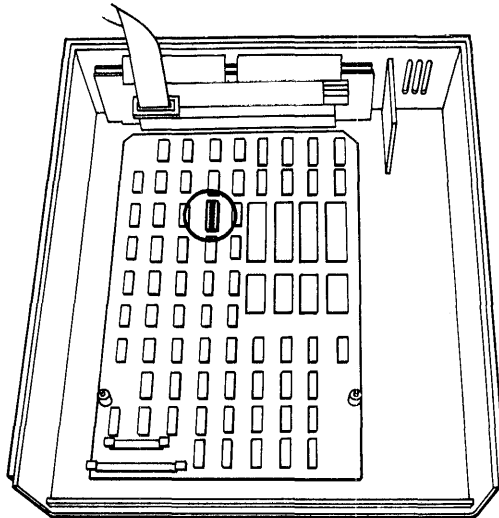
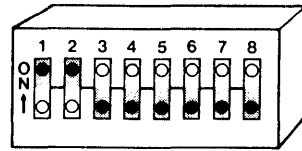
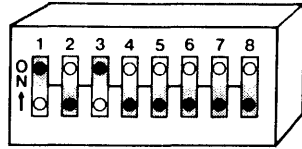

Figure 2-5. Controller Address Switch Location



DRIVE ADDRESS 1



DRIVE ADDRESS 2

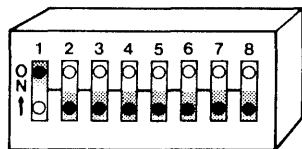

DRIVE ADDRESS 3

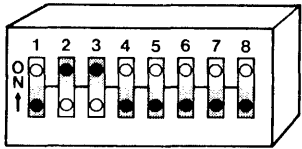

DRIVE ADDRESS 4

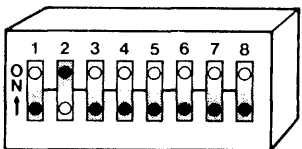

DRIVE ADDRESS 5

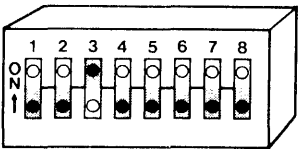

DRIVE ADDRESS 6

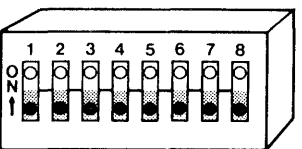

DRIVE ADDRESS 7

Shading indicates that the switch should be pushed in on that side.

Figure 2-6. Controller Address Switches

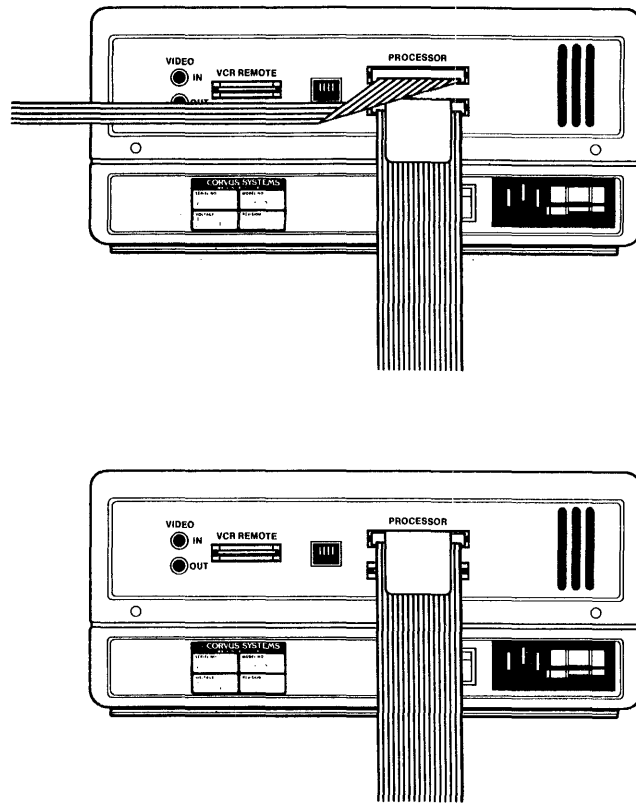

Figure 2-7. Daisy-Chaining of Disk Drives

CHAPTER 3
OPERATION

CHAPTER 3 OPERATION

3.1 Scope of Chapter

This chapter describes operator controls and their use as applies to troubleshooting and repair of the drive. Front bezel control switches and Light Emitting Diodes (LEDs) are described, and their functions detailed. Environmental requirements are discussed, and recommended regular checks for the drive are given.

Operation and initialization instructions are detailed in the Corvus "Disk System User Guide" for the appropriate host operating system.

3.2 Introduction

All Corvus 5.25-inch, 6-Megabyte drives have front bezel indicator lights and function switches. The switches must be set properly to reflect the system configuration in order for the drive to function correctly. Indicator LEDs on the front bezel display the state of the drive, and help in diagnosing the condition of the drive.

3.3 Controls

Operator controls are located on the front bezel of the enclosure. Three LEDs monitor the current state of the drive Controller. Four function switches are located under the LEDs. Rear bezel components consist of fuse and power selection unit (CORCOM), power switch, video connectors, Mirror configuration DIP switches, connectors for host processor, daisy-chained drive, and remote control VCR interface cables.

3.3.1 Front Bezel LEDs

The LEDs are labeled READY, BUSY, and FAULT. During the power-up sequence all LEDs are on, and BUSY blinks while the drive motor reaches operating speed. After the drive has completed the power-up sequence, the READY signal will be set, the READY LED will be on, and the BUSY and FAULT LEDs will be off.

During normal operation, the READY LED is active when the drive is ready to receive a command from the host processor. The BUSY LED is active when the drive is currently executing a command received from the host processor. The FAULT LED is active when command execution has been interrupted due to the occurrence of an error. The FAULT LED is an indicator of drive malfunction or operational error, although some software may cause this LED to light during normal operation. The FAULT LED function is accompanied by an error code displayed on the computer screen.

3.3.2 Front Bezel Switches

The function switches are located below the LEDs on the front bezel. These are (from left to right) LSI, MUX, FORMAT, RESET. During normal operation, in a single-user system without an LSI-11 computer, all switches should be set to the left.

All switches except for the RESET switch are software switches. The Controller ROM routine polls the switches to ascertain system configuration. Only the RESET switch directly affects the hardware.

Located farthest to the left, the LSI switch is a two-position switch; the OFF (left) position is the normal position, the ON (right) position is for use with a DEC System LSI-11. At power-on time, the controller polls this switch. If a DEC LSI-11 computer is attached, it loads the DEC RL01™ and RL02™ disk drive emulation routines from the Controller Firmware area into controller RAM.

The next switch, the MUX switch, is also a two-position switch; the OFF (left) position is the single-user position, the ON (right) position is for use with the Corvus Multiplexer Network™. At power-on time, the controller polls this switch to determine if a Multiplexer is attached. If a Multiplexer is connected, it then loads the Multiplexer polling routine from the Controller Firmware area into controller RAM.

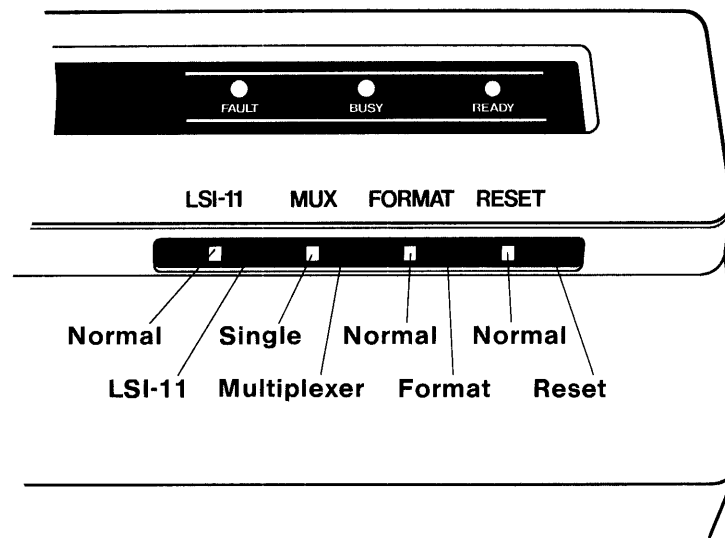

Figure 3-1. Front Bezel Configuration Switches

The FORMAT switch is a two-position switch; left position is OFF (normal), right position is ON. This switch serves two functions. First, when the drive is turned on, the controller checks all front bezel switches. If the FORMAT switch is ON (right) at this time, the drive will come READY if the ROM-based self-test completes successfully. If, however, this switch is OFF, the controller reads the Controller Firmware from cylinders 0 and 1 into the on-board controller RAM. If this procedure is successful, the controller sets the READY signal, the READY LED is lit, and the BUSY and FAULT LEDs are extinguished. The drive is now ready to accept a command from the host system. Secondly, the FORMAT switch must be on for the diagnostic program F)ORMAT to execute (see chapter 7 "DIAGNOSTICS"). In this mode the switch acts only as a hardware safety switch. No one may execute the F)ORMAT program without having physical access to the drive. The switch being turned ON alone will not format the drive. Only the combination of the format software and the FORMAT switch will allow one to format the drive. If this switch is ON during normal operations, communication between the drive and the host system may be impaired.

Located farthest to the right, the RESET switch is a spring loaded, momentary-contact toggle switch. Toggling this switch initiates a reset signal which resets the intelligent controller in the drive to its original power-on state: the heads rezero and the disk Controller Firmware is again loaded from the disk into the controller RAM. The drive is then ready to accept another command from the host processor.

3.4 Power-On Sequence

No specific sequence need be followed when powering on the Corvus Disk System, with one exception. If the Corvus disk drive is used with an OMNINETTM local network, power on the Disk Server first. Next power on the disk drive, then the host computer. This procedure supersedes all other procedures that may be found in previous Corvus publications.

3.5 Environmental Requirements

All working environments contain possible hinderances to proper operation of electronic equipment. The following are some environmental problems and their solutions.

3.5.1 Static Electricity

Static voltages of thousands of volts can be generated in most office environments. If a system shows irregularities whenever an operator comes in contact with the host computer, network or peripheral equipment, supporting table or surface, static should be suspect.

Static is most easily generated in a cool and dry environment, usually associated with cold weather. Since increased humidity helps prevent static electricity buildup, some type of humidifying device can be helpful. Ideal relative humidity is 70 percent to 75 percent.

3.5.2 Line Noise

Electrical noise on the power line is a major cause of inconsistent equipment operation. Voltage spikes, "brownouts" and dropouts as well as low line voltage are just some of the common causes of drive malfunction.

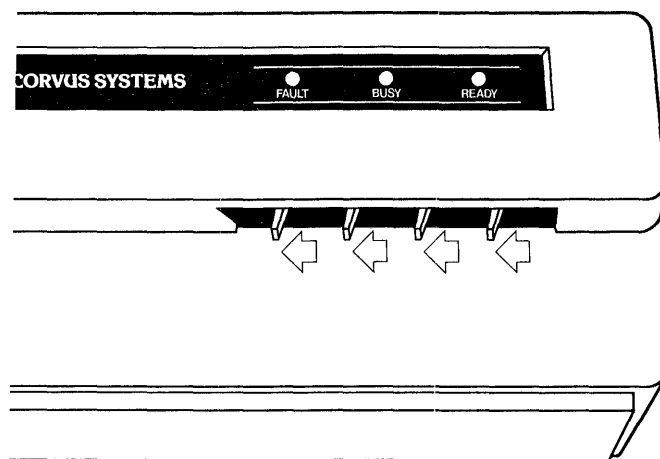

Figure 3-2. Single-User Front Bezel Switch Positions

Located in the CORCOM power selection unit is a line filter capable of handling minor electrical noise on the power line. Also, the power supply is capable of handling dropouts of up to three complete power cycles.

If power is suspect, the problem may lie in poor continuity of the building wiring, noisy or high power-consumption devices on the same circuit, or poor external supply to the building. Power can be improved by including a constant voltage regulator or isolation transformer in the power circuit. The constant voltage regulator will help minimize the effect of line voltage fluctuations on the Corvus Drive, while the isolation transformer will be effective in protecting the Corvus Drive from line noise caused by other high-load electrical equipment such as photocopier machines, heating and cooling equipment, elevators, etc. To lessen the impact of frequent power interruption, the use of an uninterruptible power supply (UPS) is recommended.

3.5.3 Temperature

Although in most environments, the disk drive needs no actual warm-up time, there are temperature limits that the drive must operate within (see specification chart at beginning of this manual). The temperature-change maximum for the Corvus disk is 15 degrees Fahrenheit per hour.

3.6 Periodic Maintenance

Inherent in the design of the Winchester technology disk devices, is the freedom from the need for regular preventive maintenance. The sealed disk mechanism of the Corvus disk drive requires no maintenance, and contains no field-serviceable components.

CAUTION:

Since contamination of the atmosphere in the mechanism necessitates replacement of the unit, removing the cover to the sealed mechanism voids all warranties.

3.6.1 Regular Checks

Each time the drive cabinet is opened, check the power supply voltages to verify that they are within specified tolerances (refer to chapter 6 for adjustment procedures). Power supply voltages will change with time, and should be checked periodically.

Due to slight oxidation buildup on cable connectors and IC pins, reseating flat cable and power connectors and chips periodically will also help insure reliability.

[™]RL01 and RL02 are registered trademarks of Digital Equipment Corp.

CHAPTER 4
DRIVE DESCRIPTION

CHAPTER 4 DRIVE DESCRIPTION

4.1 Scope of Chapter

This chapter provides a description of the components of the Corvus B-Series 5.25-inch, 6-Megabyte Disk Drive and their interactions. Some terms are defined to help provide a foundation for the descriptions.

4.2 Introduction

The Corvus 6-Megabyte Drive is divided into two basic revision groups:

- 1) Rev A Drive
- 2) Rev B through Rev E Drives

Each of these is further divided into three functional groups; Power Supply, Disk Sealed Mechanism, and Controller Electronics. These are defined as modules, and are field-replaceable as such.

As mentioned elsewhere in this manual, five versions of the Corvus 5.25-inch, 6-Megabyte drive were manufactured. A drive may be identified by the revision noted on the serial number tag located on the rear bezel.

4.3 Drive Revisions

All Revisions have:

- Disk Sealed Mechanism
- Power Supply or Supplies
- Backplane PCA
- Controller PCA
- Mirror PCA (if installed)
- Paddleboard PCA
- Drive Cabinet

4.3.1 Revision A Drive

The Rev A drive was shipped only in a metal drive cabinet, which contains the dual power supplies, as well as the early version sealed mechanism. This early disk mechanism can be identified by the two PCAs located on the underside of the sealed unit. The drive sealed mechanism, as well as the two PCAs underneath it, is unique to the Rev A and may not be interchanged with units of another revision.

The Revision A drive uses two power supplies. All other Corvus drives use single power supplies. Neither of the Rev A's power supplies is interchangeable with supplies of other revision Corvus drives. The dc power cable, originating at the power supplies, terminates with three power connectors which connect to the two pc boards underneath the drive mechanism, and the one on the Backplane PCA.

The Backplane PCA is attached to the drive cover with brackets. The Backplane has two card slots which accept the Controller PCA (nearest the cover) and the Mirror PCA (when installed). While physically similar, the Rev A Backplane is not interchangeable with other revisions of the 6-Megabyte drive.

The Controller PCA is located in the uppermost slot of the Backplane PCA. Although this circuit board is physically identical to the Corvus 8-inch, 11- and 20-Megabyte drive Controller PCA, it is not electrically compatible, and therefore not interchangeable. The Rev A Controller is also not interchangeable with the Rev B through Rev E 5.25-inch drives.

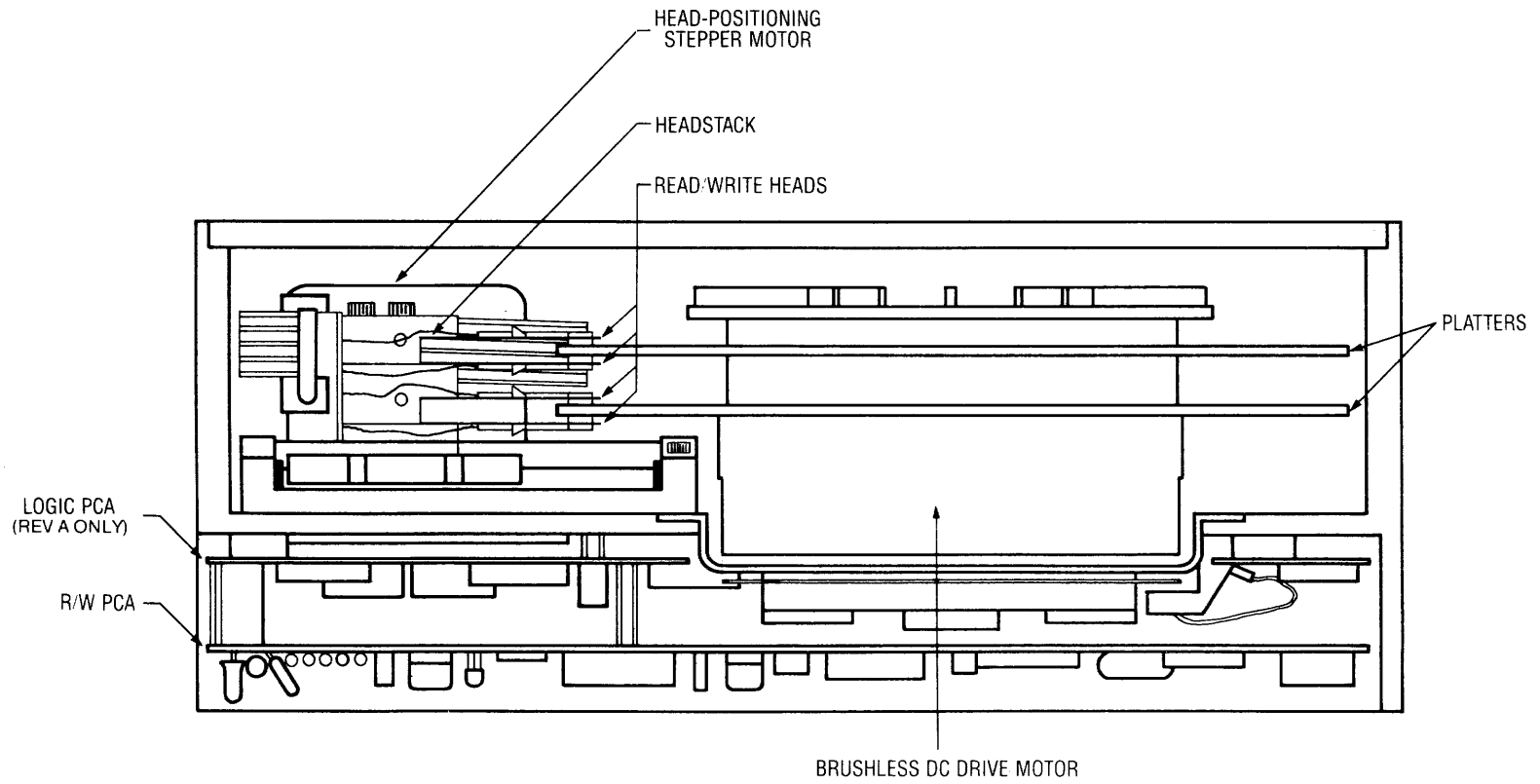

Figure 4-1. Disk Drive Sealed Mechanism

The Mirror PCA is located in the lower slot (farthest from the cover) of the Backplane PCA. The 5.25-inch Mirror is compatible with all versions of Corvus 5.25-inch disk drives. All Corvus 6-Megabyte drives have four DIP switches on the rear of the drive which **MUST** be configured to reflect the internal configuration of the Mirror PCA. If the drive has no Mirror PCA installed, the switches must be selected to reflect this configuration. Likewise, if a Mirror PCA is installed, the switches must be reset to reflect this change. See the table below for the proper switch settings.

Mirror Switch Settings

	Switch 1	Switch 2	Switch 3	Switch 4
External Mirror or No Mirror	Closed	Closed	Closed	Closed
PAL/SWCAM Mirror	Closed	Open	Open	Open
NTSC Mirror	Open	Open	Open	Open

The front bezel Paddleboard PCA contains the four function switches: FORMAT, RESET, MUX, and LSI-11, as well as three LEDs: FAULT, BUSY, and READY (see chapter 2 "Operation" for a full description of these components). The Paddleboard used on all 5.25-inch drives and on most 8-inch drives is compatible, and therefore interchangeable.

4.3.2 Revision B Drive

The Rev B drive retained the metal cabinet of the Rev A drive, but acquired all new internal components. The new drive sealed mechanism can be identified by the one Read/Write PCA located underneath the drive unit. This mechanism with its one Read/Write PCA is shared with the Rev B through Rev E 5.25-inch, 6-Megabyte drives, and are completely interchangeable.

The Rev B power supply is a single unit, the same one used in the later drive revisions supplying +12V and +5V, and is therefore completely compatible with the Rev C through Rev E drives. The Rev B power supply is not compatible with the Rev A model, and cannot be interchanged.

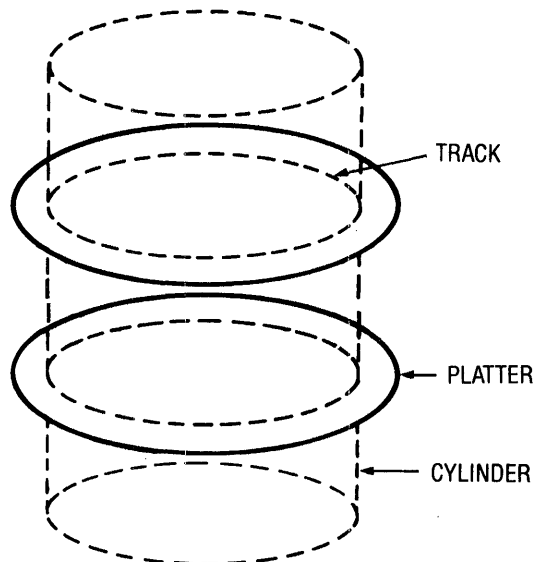

Figure 4-2. Data Configuration

The Rev B Backplane PCA is attached to the drive cover via standoffs. The Backplane PCA has two card slots which accept the Mirror PCA (when installed) and the Controller PCA (nearest the cover). The Rev B Backplane is the same one used in the Rev C through Rev E, B-Series 6MB drives and is interchangeable between these three later drive revisions. The Rev B Backplane PCA is not compatible with the Revision A drive and may not be interchanged.

The Controller PCA is identical to the Rev C through Rev E, B-Series 6MB drives and is interchangeable between these four drive revisions. The Rev B Controller PCA is not compatible with the Rev A drive, and is not interchangeable.

The Mirror PCA used with 5.25-inch drives is interchangeable between all H-Series and B-Series drives of this size (5.25-inch).

The front bezel Paddleboard PCA is the same PCA used in all revisions of the 5.25-inch drive and most versions of the 8-inch drives, and is interchangeable between these drives.

4.3.3 Revision C, D, and E Drives

With the exception of the cabinet, the Revision C drive is identical to the Revision B drive. The Rev C drive uses a white plastic cabinet, while the Rev D and Rev E drives use a gray plastic cabinet. Both drives contain the same components as the Revision B drive. Slight differences in mounting hardware may exist with the plastic cabinet, but all internal components of the Rev C, D, and E drives are identical to the Rev B drive. (For details on the components of the Rev C, D, and E drives, refer to the previous descriptions for the Rev B drive.)

4.4 General Description

The recording media of the Corvus 5.25-inch Winchester disk drives consists of an nickel-oxide coating on aluminum disks called platters. There are two 5.25-inch platters in all B-Series 6-Megabyte drives, all four surfaces being utilized for data storage. One head rides above each surface on an 18-microinch air bearing (air cushion).

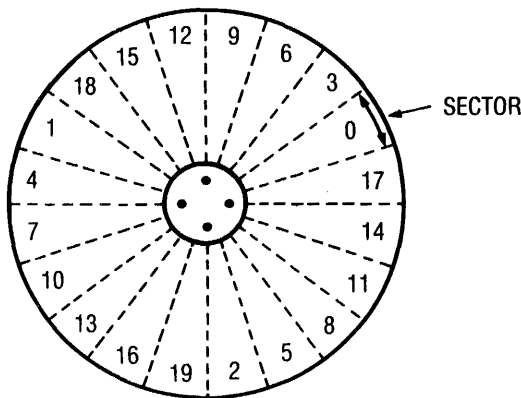

Figure 4-3. Sector Interleaving

Data is stored magnetically on circular tracks, which are configured as concentric circles on each platter. Each track is further divided radially into 20 sectors, each sector containing one 512-byte block of user data. The term track refers to a single head surface of a cylinder, each cylinder consisting of one track from each surface (four total), in common vertical alignment. There are 144 cylinders on the 5.25-inch, B-Series 6-Megabyte drive, with cylinder zero located farthest from the platter center.

A block is the smallest addressable quantity of data within the drive. Internally, each block consists of 512 bytes of data. Externally, the drive handles data in sectors as defined by the host computer.

Typically, each host operating system defines a sector as 128 bytes, 256 bytes or 512 bytes. The Corvus interface software uses the appropriate read and write commands (one each for writing and reading 128, 256 or 512 bytes) depending on the type of operating system.

This does not cause a conflict, since the drive simply stores 1,2 or 4 host-defined sectors for each block. Read and write commands of less than 512 bytes are transparent to the host system, due to the Intelligent Controller's ability to handle data blocking internally.

4.4.1 Disk Sealed Mechanism

The Corvus mass-storage disk mechanism uses a combination of both new Winchester technology and traditional disk design.

The 5.25-inch platters revolve on a common spindle, driven by a brushless dc motor at a speed of 4800 RPM. Motor speed is monitored and automatically adjusted at the motor, and is independent of line frequency. A sector disk is located at the lower end of the spindle, and is monitored by an LED and phototransistor which provide sector pulses to the drive electronics. A solenoid brake contacts the motor hub after power-off.

Each head glides 18-microinches (18 millionths of an inch) from the platter surface on an air bearing, or air cushion. A particle of smoke or dust, or a human hair could easily play havoc with with these critical tolerances, and cause catastrophic failure of the disk device. The seal on the drive cover keeps the internal atmosphere contaminant-free. **BREAKING THIS SEAL FOR ANY REASON, VOIDS ALL WARRANTIES.**

The heads are held by flexure arms, attached to a common head stack casting which moves on precision bearings and stainless steel rails. Positioning of the heads over the appropriate cylinder is done by a three-phase stepper motor, connected to the head stack by a stainless steel band. Seeking to a specific cylinder is accomplished by stepping the motor through three phases for each cylinder. Simply reversing the sequence of these motor phases will result in reversing the direction.

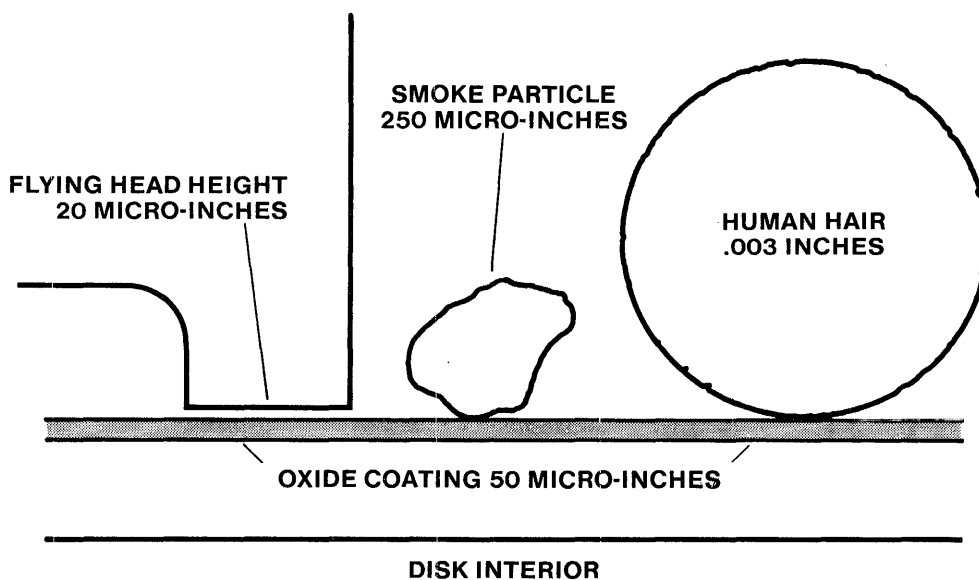

Figure 4-4. Disk Drive Contaminants

Mounted beneath the drive mechanism is either one PCA (Revision B through Revision E drives) or two PCAs (Revision A drives). These are the Logic PCA, and the Logic PCA and Read/Write PCA, respectively. Since these are considered integral components of the sealed mechanism, individual replacements for these PCAs are not available. If either of these PCAs are diagnosed as defective, the entire disk mechanism must be replaced.

4.4.2 Power Supply

Every Corvus 6-Megabyte Drive comes with a power supply(ies) to provide all voltages required by the drive mechanism and drive electronics. The two drive groups (Rev A, and Rev B through Rev E) have different drive mechanisms which require different voltages. The Rev A drive mechanism requires +12V, -12V, +5V, and -5V, while the Rev B through Rev E drive mechanism requires only +12V and +5V.

4.4.2.1 CP134 (Rev A)

The CP134 is a black, open-chassis power supply (the larger of the two Rev A power supplies), which provides the +12V, -12V and -5V voltages required by the drive. All three voltages are adjustable. The CP134 is mounted in the metal drive cabinet, along with the HB5 power supply.

4.4.2.2 HB5 (Rev A)

The HB5 is the smaller of the two power supplies mounted in the Rev A metal cabinet, and provides +5V required by the drive. The +5V is adjustable.

4.4.2.3 CP417 (Rev B through Rev E)

The CP417 is the only power supply required by the Rev B through Rev E 6-Megabyte Drives. Providing the +12V and +5V required by the drive components, the CP417 is used in the metal cabinet (Rev B) and the plastic cabinet (Rev C, D, and E) drives.

4.4.3 dc Power Cables

All power supplies connect to a dc power cable which then connects to the disk mechanism and the drive Backplane PCA. All dc power cables attach to solder terminals on the power supply PCB.

4.4.3.1 Rev A dc Cables

The Rev A power cable connects the two power supplies with the two PCAs on the underside of the drive mechanism, as well as the Backplane PCA connector. The power connectors for these PCAs are paralleled, and are interchangeable. These are polarized, to assist proper connection.

4.4.3.2 Rev B through Rev E dc Cables

In later drive revisions, the power supply cable connects the single power supply to the single PCA on the underside of the disk mechanism, and to the Backplane PCA. The power connectors are also polarized, to assist proper connection.

4.5 Controller Firmware

Corvus reserves the first two cylinders of the drive for system information. This is referred to as Controller Firmware, and is not accessible to the host operating system. This firmware contains programming and system parameters needed by the Z-80 drive controller which is loaded into the disk drive RAM when the drive is powered on or the RESET switch is toggled. The MIRROR driver routines, spare track table, Multiplexer parameters and Semaphore status flags are a few examples of Controller Firmware. Identical copies of Firmware reside in each of the two cylinders. The rest of the disk area is available to the host system for data storage, the configuration of which depends upon the type of host operating system.

4.6 Data Storage

Data storage arrangement is by concentric tracks aligned in vertical cylinders. Each track is sectioned into 20 sectors, each sector has a capacity of 512 eight-bit bytes. Logical sectors are numbered by using an interleaving specification of twelve (for the B-Series, 5.25-inch drives), except for use with the DEC LSI-11 which uses an interleaving specification of six (B-Series drives only).

All four surfaces are used for data storage. All four heads transfer digital information to and from the platters.

Contained in the head stack is the microchip. This head select and driver microcircuitry is responsible for selecting which head is being used, and transmitting the signal to the drive electronics for further amplification.

4.7 Transportation Considerations

The Corvus B-Series 6-Megabyte, 5.25-inch Disk Drive has no locking device for the head carriage. This requires one careful consideration before transporting the drive; after powering off the drive, wait for the motor to stop spinning before moving the drive.

When the drive is powered off, the heads will not move. This means that heads rest on the data area of the media when the drive is shipped. If, when the drive is transported, it is subjected to rough handling, the heads will impact the disk surface in a critical area, possibly causing damage to the media. Gentle handling of the drive is essential for the drive to survive shipping.

4.8 Theory of Operation

The Revision A, and Revisions B through E 6-Megabyte, 5.25-inch drives are, though physically dissimilar, functionally similar. Controller Firmware version CF15.0 or greater, and all associated drive initialization utilities, may be used.

4.8.1 Power-Up

As soon as the power supply voltages have stabilized, the Z-80 Controller board begins a routine which initializes the Z-80 microprocessor, and then executes a ROM-based self-test. The test checks the on-board RAM, and then a bit-sum check is done to the ROM. If the self-test fails, the Z-80 halts execution, leaving the FAULT and BUSY LEDs on, and READY LED off.

If the self-test executes successfully, the drive begins the firmware boot routine. This consists of first rezeroing the heads, bringing them over the first cylinder of the disk surfaces. The FORMAT switch is then sampled. If the switch is on, the Controller sets the READY signal. If it is off, the Controller Firmware is read from the first cylinder into the on-board RAM. If the firmware is successfully read the drive comes READY. If a bad block is encountered while reading the firmware, the Controller will attempt to read from the second copy any bad sectors found in the first. It will continue to read alternate copies from the disk until all Controller Firmware is successfully loaded into the Controller RAM.

4.8.2 Controller PCA

The Z-80 Drive Controller is responsible for interpreting commands sent from the host computer system and controlling the sub-assemblies; drive mechanism (with its Logic and/or Read/Write PCA) and Mirror PCA (when installed). The Controller reports back to the host computer the success of the command executed by means of a return code. During a write command, the Controller generates CRC bytes for each block of data written, and checks the block against the CRC value during the read command.

The Controller PCA contains the Z-80 CPU and support logic as well as Controller ROMs (containing procedural Z-80 code for the Intelligent Controller) and on-board RAM (used for buffering data to and from the disk, and utility code loaded from the Controller Firmware area of the disk). Also, four Z-80 PIO ICs are used to buffer signals to and from the Corvus Mirror, Multiplexer Network, and drive sealed mechanism. In addition, the CRC generator/checker error signal is monitored by one of the PIO ICs, and informs the Z-80 CPU in the case of a CRC error.

The Controller PCA communicates to the host computer system through a 34-pin flat cable.

4.8.2.1 Controller During Seek Command

When the drive is requested to read or write a specific sector, the Controller first verifies the sector address as valid. Next, the Read/Write PCA is then commanded to strobe the stepper motor windings (phase 1-4). The Controller decrements the cylinder count one for each full motor phase sequence (1-4) and halts the stepper motor at the appropriate cylinder. The next sector to move past the heads is read to verify the success of the seek. If the incorrect cylinder was reached, the heads are rezeroed and the seek is attempted again. If the seek fails during the retry, the drive halts operation, and an error is returned to the host operating system.

4.8.2.2 Controller During Read and Write Commands

The write command begins when the command is received, along with the sector address(es). The Z-80 Controller determines whether the write command is for 128, 256 or 512 bytes, and relinquishes control to the DMA circuitry for transfer of the data from host memory to the onboard Controller RAM.

During host-to-drive transfer, the processor is put into a wait state while the DMA circuitry transfers the data from the host memory to the on-board RAM. The DMA circuitry uses the Z-80 processor as an address counter, and when the first byte is received from the host system, the DMA circuitry uses the address specified by the Z-80 to write the byte into on-board RAM. Between data byte transfers, the Z-80 is released from its wait state just long enough to increment its address counter.

Once the data is in RAM, control is returned to the Controller which performs a seek to the appropriate cylinder, if necessary, and reads the first available header to verify the seek. The DMA circuitry clears the CRC generator/checker, and waits for the proper sector to pass under the head. If the required write function is less than 512 bytes, the block is read in from the sector and the host information is overlaid into the appropriate locations of the block.

Next, preparations are made for writing that block out to the disk. When the proper sector comes around, the Controller again turns control over to the DMA circuitry. The Drive processor again is put into a wait state while the DMA transfers data bytes one at a time to the parallel-to-serial converter. A CRC value is generated from the serial data and inserted in the data stream, and both are then sent to the read/write circuitry for output to the heads. The CRC information is used for checking data integrity when read from the disk.

The disk write operation is concluded by reading in the block to verify its success. The bus direction is then reversed, and a status byte (return code) is sent to the host system indicating the result of the disk write.

4.8.3 Backplane PCA

The Backplane PCA is responsible for transferring power and signals between the Controller PCA, Mirror PCA, Paddleboard PCA, and the Host Interface PCA (via the rear bezel 34-pin connector). The upper slot of the Backplane is reserved for the Controller PCA, and the lower slot is reserved for the Mirror PCA. These two PCAs may not be interchanged.

This two-piece PCA accepts flat cables from the front bezel Paddleboard PCA and the Drive Sealed Mechanism (Revision A only), as well as from the host computer System. A single dc power cable supplies voltage to the Backplane PCA via a four-pin connector.

The Backplane PCA for the Revision A drive is unique to that revision, and is not interchangeable with other revision drives. The Backplane PCA for the Revision B through E drives use the same Backplane PCA and is interchangeable between those four drives, but cannot be used in the Revision A drive.

4.8.4 Paddleboard PCA

The Paddleboard PCA, located on the front bezel of the drive enclosure contains switches and LEDs. The functions of these controls are detailed in chapter 2.

All Paddleboard PCA revisions are compatible with all drive revisions, and are interchangeable.

4.8.5 Interface PCA

The Corvus disk system may be configured for any of several different microcomputer systems, and may be purchased with one of many Corvus interface cards available.

The typical interface card contains address decoding, bidirectional data buffering, and handshaking circuitry. Some interface cards also have ROMs with boot routines for booting the microcomputer from the Corvus disk. Some do not, and these computers must boot from floppy diskette.

Connected to the 34-pin flat cable, the Interface PCA contains two input ports, and one output port and address decoder. One input port is an eight-bit tri-state data buffer, used for receiving data bytes during drive-to-host transfers. The other input port is the status port, used for determining the state of the disk drive. The output port is an eight-bit latch, used in host-to-drive data transfers.

When the host system needs to access the disk, it first checks the BUS DIRECTION signal, and if the bus is in the host-to-drive direction, and the READY signal is high, the drive is ready to accept a new command. The host now sends command bytes to the drive.

During a read or write command, the bus will remain in one direction without turning around, until all bytes have been transferred. The drive will acknowledge the acceptance and execution of commands by setting the bus direction bit of the status port. This is a signal that the return code is on the data bus, which must be retrieved before the drive will accept new commands.

**CHAPTER 5
DISASSEMBLY**

CHAPTER 5 DISASSEMBLY

5.1 Scope of Chapter

With the possible exception of the cooling fan and Backplane PCB, the Revision A, and Revisions B through E drives' configurations differ significantly. Therefore, separate disassembly instructions are given for each of these two configurations.

These two configurations were installed in different cabinet designs. Disassembly of the metal cabinet drives is covered in section 5.3, while the plastic cabinet drives are covered in section 5.4.

5.2 Introduction

The Corvus B-Series 6-Megabyte 5.25-inch disk drives were manufactured in two basic functional revisions: the Rev A, and the Rev B thru Rev E. These drives were delivered in two basic packages: the white metal cabinet, and the narrower white or gray high-impact plastic cabinet. All Rev A and Rev B drives were delivered in metal cabinets, while Rev C drives used the white plastic case. The Rev D and Rev E drives are identical to the Rev C, except the case color has been changed to grey.

WARNING:

Before disassembling any disk equipment, be sure power is disconnected.

5.2.1 Tools Required

The following tools are required for disassembly of the Corvus Revisions A through E 6-Megabyte drives:

- 1) #2 phillips screwdriver
- 2) 5/64-inch hex allendriver
- 3) 9/64-inch hex allendriver
- 4) 1/4-inch nutdriver
- 5) 5/16-inch nutdriver

5.3 Metal Package

The Rev A drive components differ from the Rev B components, but both use the white metal cabinet. The following instructions cover both metal packages; differences between the revisions are noted.

5.3.1 Top Cover

1. Remove the six screws securing the top cover to the basepan.
2. Remove the cover straight up, being careful not to stress the ac wiring and flat cables connected to the cover.

5.3.2 Controller PCA

5.3.2.1 Rev A Drives

1. Remove the two screws securing the Controller PCA to the cover.
2. Remove the PCA by gently pulling it out of the Backplane slot.

5.3.2.2 Rev B Drives

1. Remove the drive mechanism flat cable from the upper connector of the Controller PCA noting its orientation.
2. Remove the two allen screws securing the PCA to the cover.
3. Remove the PCA by gently pulling it out of the Backplane slot.

5.3.3 Backplane PCA**5.3.3.1 Rev A Drives**

1. Disconnect the one dc power cable and two 34-pin flat cables from the Backplane, noting their orientation.
2. Remove the four phillips screws securing the angle brackets to the cover.
3. Remove the Backplane by moving it down and forward.

5.3.3.2 Rev B Drives

1. Disconnect the one dc power cable and one flat cable from the backplane, noting their orientation.
2. Remove the four allen screws securing the Backplane to the cover.
3. Remove the Backplane by moving it down and forward.

5.3.4 Drive Mechanism

1. Remove the four allen screws securing the drive mechanism mounting brackets to the basepan.
2. Remove the dc power cable(s) and flat cable from the drive mechanism.
3. Remove the drive mechanism and brackets up and out of the basepan.
4. Remove the four allen screws securing the bracket(s) to the drive mechanism, and remove the bracket(s).

5.3.5 Power Supplies**5.3.5.1 Rev A Drives****NOTE:**

The two power supplies in the Rev A drive share common wiring and must be removed together.

1. Disconnect the two ac wiring harness connectors from the rear bezel CORCOM unit and power switch.
2. Disconnect the dc wiring cables from the drive mechanism and the Backplane PCA.
3. Disconnect the ac fan cord from the cooling fan.
4. Remove all eight allen screws securing the two power supplies to the basepan.
5. Remove the power supplies, together, straight up and out of the basepan.

5.3.5.2 Rev B Drives

1. Disconnect the ac wiring harness connector from the rear bezel CORCOM unit and power switch.
2. Disconnect the dc wiring cables from the drive mechanism and the Backplane PCB.
3. Disconnect the ac fan cord from the cooling fan.
4. Remove the four screws securing the power supply to the basepan.
5. Remove the power supply straight up and out of the basepan.

5.3.6 Front Bezel

1. Remove the flatcable from the front bezel paddleboard PCA, noting its orientation (one edge down).
2. Remove the four allen screws securing the front bezel to the support brackets.
3. Remove the bezel straight forward.

5.4 Plastic Package

The high-impact plastic case was implemented with the Rev C, Rev D and Rev E drives. These drives share the same components as the metal case Rev B drive.

5.4.1 Top Cover

1. Remove the two screws at the rear of the cover.
2. Remove the cover by sliding it back and lifting it straight up. Be careful not to stress the dc cabling and flat cables connected to the Controller PCA and the Backplane PCA.

5.4.2 Controller PCA

1. Remove the drive mechanism flat cable from the upper connector of the Controller PCA noting its orientation (one edge to the left).
2. Remove the two nylon standoffs (allen screws are found in some instances) securing the PCA to the cover.
3. Remove the PCA by gently pulling it out of the Backplane slot.

5.4.3 Backplane PCA

1. Disconnect the one dc power cable and one flat cable from the Backplane, noting their orientation.
2. Release the forward Backplane PCA from the nylon standoffs (in some drives the allen screws must be removed to accomplish this).
3. Remove the five nylon stand-offs securing the Backplane to the cover.
4. Remove the Backplane by moving it down and forward.

5.4.4 Drive Mechanism

1. Remove the four allen screws securing the drive mechanism mounting brackets to the basepan.
2. Remove the dc power cable and flat cable from the drive mechanism.
3. Remove the drive mechanism and brackets up and out of the basepan.
4. Remove the four screws securing the bracket(s) to the drive mechanism, and remove the bracket(s).

5.4.5 Power Supply

1. Disconnect the ac wiring harness connector from the rear bezel CORCOM unit and power switch.
2. Remove slot screw securing the ground wire to the power supply.
3. Be sure the dc wiring cables are disconnected from the drive mechanism and the Backplane PCA.
4. Disconnect the ac fan cord from the cooling fan.
5. Remove the four allen screws securing the power supply to the basepan.
6. Remove the power supply straight up and out of the basepan.

5.4.6 Front Bezel

1. Remove the flat cable from the front bezel Paddleboard PCA, noting its orientation (one edge down).
2. Remove the three screws securing the front bezel to the basepan.
3. Remove the bezel straight forward.

CHAPTER 6
ADJUSTMENTS AND MAINTENANCE

CHAPTER 6 ADJUSTMENTS AND MAINTENANCE

6.1 Scope of Chapter

This chapter will cover the check and adjustment of power supply voltages. The Corvus B-Series 6-Megabyte drive has no other adjustments.

6.2 Introduction

The Corvus disk system is based on a Winchester disk mechanism. Because of this storage device's sealed environment, this mechanism requires no preventive maintenance.

6.3 Power Supply Voltage Check and Adjustment

Aging of the power supply and normal heating and cooling of the drive electronics can cause the power supply voltages to drift over time. Voltages should be checked each time the installation is visited for system checkout.

WARNING:

Extreme caution should be exercised when adjusting the power supply. High voltages present a potential hazard.

6.3.1 Rev A Drives (Dual Power Supplies)

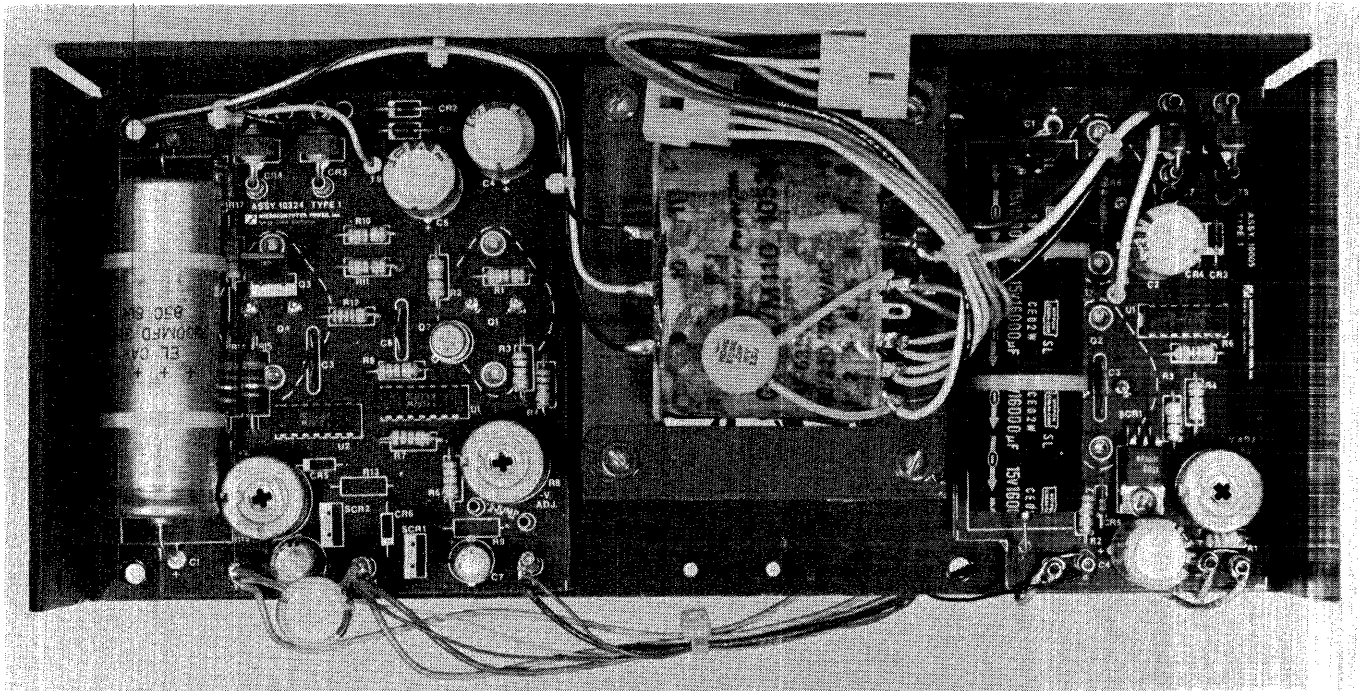

Figure 6-1. CP134 Power Supply from Rev A Drive

6.3.1.1 Voltage Check (CP134):

1. Remove cover to the enclosure as outlined in chapter 5.
2. Locate voltage test points at the edge of the CP134 power supply (larger of the two). These are labeled +V, COM, COM, -V.
3. Turn on the ac power switch.

- Using a DIGITAL voltmeter, check the power supply voltages at these connections, using the corresponding COMMON test point for each voltage. All voltages must be within ± 0.1 volts of the specified voltage.
- If any of the voltages are out of tolerance, follow the adjustment procedure for this supply.

6.3.1.2 Voltage Adjustment (CP134):

- Remove the ac power from the disk drive.
- Remove the cover to the enclosure as outlined in chapter 5.
- Connect the ac power to the disk drive, and turn on the ac power switch.
- Monitoring the dc voltages as outlined above, adjust the -12V, and +12V using the following adjustments:

CP140

R-19	+12V
R-8	-12V
R-5	-5V

NOTE:

During adjustment, one of the voltages may drop to or near zero. This is due to the over-voltage protection circuitry being activated. To reset this condition, turn off the ac power switch, and bleed the particular voltage to ground using a 10-K resistor. Set the trim resistor to its original position, turn on ac power and proceed with the adjustment.

- Turn off the ac power switch.
- Replace the drive cover and screws.

6.3.1.3 Voltage Check (HB5):

- Remove the cover to the enclosure as outlined in chapter 5.
- Locate the voltage test points at the edge of the HB5 power supply (smaller of the two). These are labeled +V, COM, -V.
- Turn on the ac power switch.
- Using a DIGITAL voltmeter, check the power supply voltages at these connections, using the corresponding COMMON test point. All voltages must be within ± 0.1 volts of the specified voltage.
- If any of the voltages are out of tolerance, follow the adjustment procedure for this supply.

6.3.1.4 Voltage Adjustment (HB5):

- Remove the ac power from the disk drive.
- Remove the cover to the enclosure as outlined in chapter 5.
- Connect the ac power to the disk drive, and turn on the ac power switch.
- Monitoring the dc voltages as outlined above, adjust the +5V using the following adjustments:

CP140

R-2	+5V
-----	-----

NOTE:

During adjustment, the +5V may drop to or near zero. This is due to the over-voltage protection circuitry being activated. To reset this condition, turn off the ac power switch, and bleed the +5V charge to ground using a 10-K resistor. Set the trim resistor to its original position, turn on the ac power and proceed with the adjustment.

- Turn off the ac power switch.
- Replace the drive cover and screws.

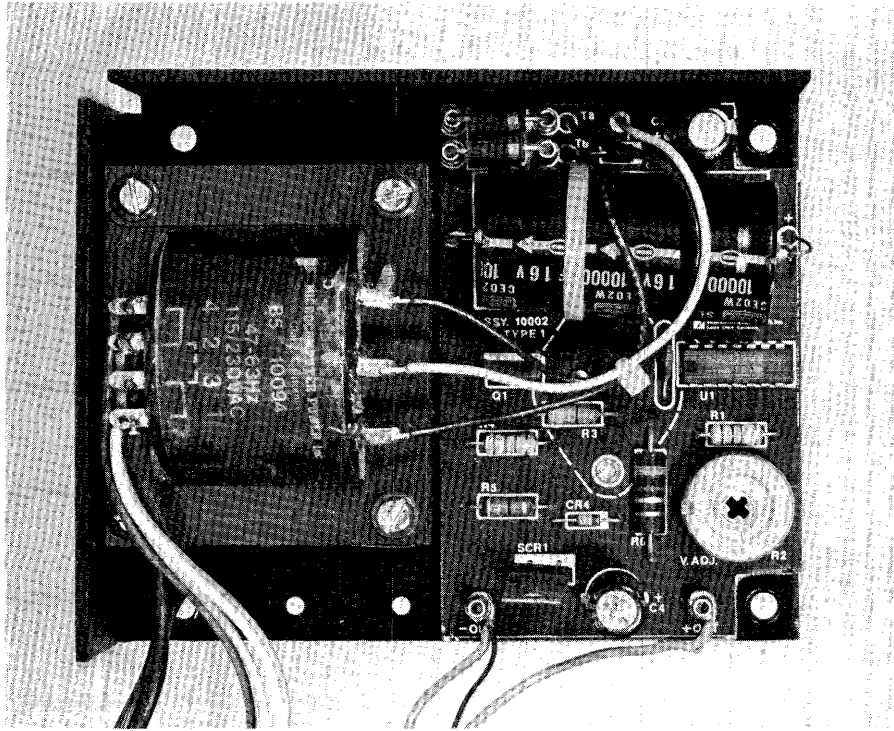

Figure 6-2. HB5 Power Supply from Rev A Drive

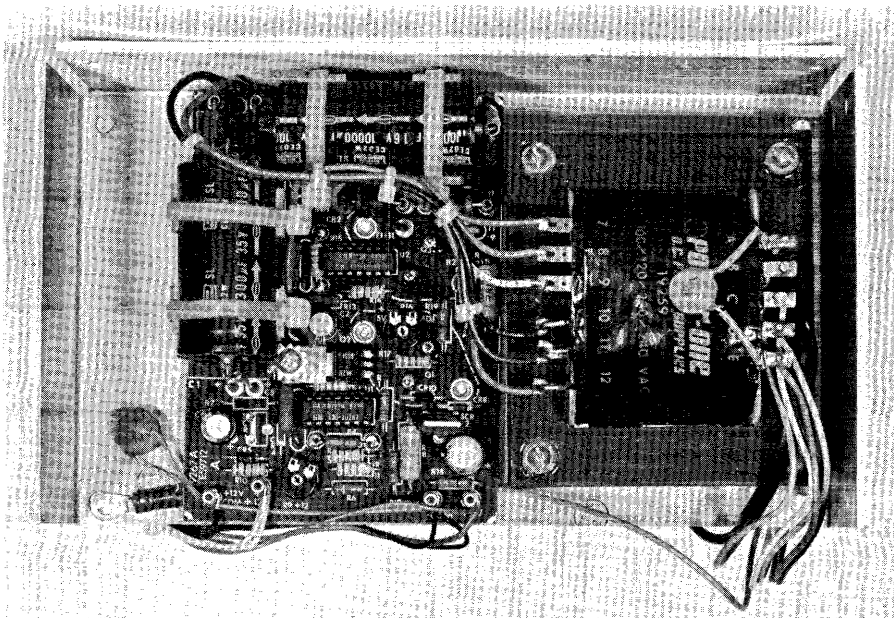

Figure 6-3. CP417 Power Supply from Rev B-E Drives

6.3.2 Rev B - Rev E Drives (Single Power Supply)**6.3.2.1 Voltage Check (CP417):**

1. Remove the cover to the enclosure as outlined in chapter 5.
2. Locate the voltage test points at the edge of the CP417 power supply (smaller of the two). These are labeled +OUT, -OUT.
3. Turn on the ac power switch.
4. Using a DIGITAL voltmeter, check the power supply voltages at these connections, using the corresponding common test point. All voltages must be within ± 0.1 volts of the specified voltage.
5. If any of the voltages are out of tolerance, follow the adjustment procedure for this supply.

6.3.2.2 Voltage Adjustment (CP417):

1. Remove the ac power from the disk drive.
2. Remove the cover to the enclosure as outlined in chapter 5.
3. Connect the ac power to the disk drive, and turn on the ac power switch.
4. Monitoring the dc voltages as outlined above, adjust the +5V using the following adjustments:

CP417

R-9 +12V

R-16 +5V

NOTE:

During adjustment, the +5V or +12V may drop to or near zero. This is due to the over-voltage protection circuitry being activated. To reset this condition, turn off the ac power switch, and bleed the +5V or +12V charge to ground using a 10-K resistor. Set the trim resistor to its original position, turn on the ac power and proceed with the adjustment.

5. Turn off the ac power switch.
6. Replace the drive cover and screws.

CHAPTER 7
DEALER SERVICE DIAGNOSTICS

CHAPTER 7

DEALER SERVICE DIAGNOSTICS

7.1 Scope of Chapter

The Dealer Service Diagnostic Utilities are supplied to aid the technician in tracing faults in the Corvus disk drive system, and speed the correction of these faults. The Drive Diagnostic, Controller Diagnostic, and Burn-In Diagnostic utilities are covered in this chapter. The Mirror and OMNINET Diagnostics are covered in the service manuals for those products.

7.2 Introduction

Each Authorized Corvus Dealer Service Center will be supplied with Dealer Service Utilities. These utilities will help the technician exercise and diagnose the Corvus disk and network systems.

The Dealer Service Utilities diskette is comprised of standard Drive Diagnostic for all the Corvus disk drives (including the H-Series drives), Controller Diagnostic which will exercise and diagnose the drive utilizing the drive Z-80 processor, and a rigorous Burn-In program which exercises and tests the drive system infinitely (i.e. overnight). Also included is a single-track read-write diagnostic, for determining the condition of an individual track.

Some versions of the diagnostic utilities display only 40 characters on the video monitor. When viewing the diagnostic menu under each specific item, typing a question mark (?) will display an additional 40 characters of menu options.

The latest release of Dealer Service Diagnostics covers all series of Corvus disk drives:

A-Series:

8-inch, 11-Megabyte drive (Revision A)

B-Series:

8-inch, 11-Megabyte drive (Revision B)

8-inch, 20-Megabyte drive (Revision B)

5.25-inch, 6-Megabyte drives (All)

H-Series:

5.25-inch, 6-Megabyte drives (All)

5.25-inch, 12-Megabyte drives (All)

5.25-inch, 18-Megabyte drives (All)

7.3 Drive Diagnostics (DRVDIAG)

This program is essentially the same program provided on the Initialization Utility diskettes supplied with each Corvus drive. All options within this program are non-destructive to data on the drive, with the exception of the Format utility. While the PARAMETERS option of the diagnostic program does not actually destroy data, changing these values using this diagnostic option will change relative track and sector addresses which will make the data inaccessible.

7.3.1 CRC

A good sector is defined as one capable of retaining all bits in the order they were written. When a block is read from a sector, the CRC value is read with it and tested. Bit errors may occur due to a bad sector, damaged in one of two ways:

- 1) physically (faulty media resulting in dropped bits and mismatched CRC bytes)
- 2) magnetically (miscellaneous bits written to the block resulting in a mismatched CRC value)

The Cycle Redundancy Check (CRC) test is a non-destructive test which reads each block of data, and checks it against its CRC value. If for any reason, the CRC value in that sector does not match the block of data, the CRC checker/generator signals the controller that an error has been detected, and the processor halts operation. Any errors will be reported at the end of the program. CRC errors encountered during normal drive operation will halt disk drive operation with the error code displayed.

Run this test several times to determine whether the error is due to faulty media (where specific sectors will repeatedly show errors) or random magnetic bit changes (where sectors will show one-time errors). Tracks containing sectors with repeated errors should be spared (using Drive Diagnostic utility PRM).

7.3.2 EXR

The exercise test (EXR) seeks random sectors and reads the header information from that sector to verify the success of the seek. Periods print to the video display for successful operations, asterisks for hard errors (errors that exist after ten retries) and question marks for soft errors (operations that succeed after at least one retry).

Pressing <RETURN> displays the error list, consisting of total number of passes (seeks), hard and soft errors. Any errors reported should be followed by a CRC test to check for faulty sectors.

7.3.3 UPD

The Controller Firmware Update utility rewrites a new copy of Controller Firmware into each of the first two cylinders of the drive. All B-Series 6-Megabyte drives must use Controller Firmware version CF15.0 or greater.

Since it is not possible to update the firmware on the boot drive, the system MUST first be booted from another boot device (another Corvus Drive, or floppy diskette).

Some versions of this utility will prompt you with:

Change Tables? (Y/N)

A negative answer to this question will not endanger data resident on the drive. Although the UPDate utility is non-destructive to the data itself, answering affirmatively to this will result in these tables being rewritten with default values:

Spare Track table = No Tracks Spared
VDO table: Drive1 = 0
Interleaving Spec = 9

This default Interleaving Spec is incorrect for the B-Series 6-Megabyte drive. Whenever the drive is formatted, or the firmware updated, this parameter must be checked and changed to 12 if needed. Be aware that whenever these default table values are written to the firmware area (by answering YES to "Change Tables?"), they replace previous values that may have been written at an earlier time. These may include spared tracks, and Interleaving Specification. If data is resident on the drive when these values are changed, all relative references to the data (absolute sector addresses) will be changed, and the data will be inaccessible afterwards.

The Format program will also rewrite these default table values.

Next, the program will display a Controller Firmware file name. This will be in the form of:

ENTER CONTROLLER CODE FILE: CFxx.x

The current level of Controller Firmware for B-Series drives at this writing is CF18.4AP. If another version is to be used, it should be entered now. The version of Controller Firmware used on the drive should be none other than that supplied with the Corvus initialization diskettes that were used when the drive was originally initialized.

7.3.4 VSN

This utility displays the current versions of the Controller Firmware and controller ROMs:

DRIVE 1: Vxx.x CORVUS SYSTEMS DD-MMM-YY
CONTROLLER ROM VERSION: nn

where DD-MM-YY represents the release date of that Controller Firmware version, xx.x represents the Controller Firmware version (i.e. CF18.4AP) and nn represents the suffix of the controller ROM (i.e. 7.63). At this printing, the current versions are:

Controller Firmware: CF18.4AP
Controller ROMs: 7.58, 8.58

7.3.5 FMT**WARNING:*****This utility will destroy data on the drive.***

Although the Format utility should be used only as a last resort when attempting to re-establish normal drive operations, the drive may at some time need reformatting. This diagnostic-level, or bottom-level format writes the rudimentary magnetic pattern to each sector required before data may be retained properly. This format must be intact before the drive can be initialized for any operating system or data storage using Corvus initialization software.

First turn the front bezel FORMAT switch to the ON (right) position, then execute the Format utility. Some versions of this utility request a password, which is HAI. When the Format has completed, the program will display:

```
FORMAT COMPLETE - NOW UPDATING FIRMWARE
ENTER CONTROLLER CODE FILE: CFxx.x
```

The program will now rewrite the Controller Firmware using the input file displayed. If another version of firmware is to be used, enter the filename now. Use only the Controller Firmware version appropriate for the drive (see section 7.3.3 "UPDATE").

The Format program writes default Drive Parameters to the drive:

```
Spare Track table = No Tracks Spared
VDO table: Drive1 = 0
Interleaving Spec = 9 (Must be changed to 12 after FORMAT)
```

and should be updated as necessary after the Format program terminates (see section 7.3.3 "UPDATE," and section 7.3.6 "PARAMETERS").

7.3.6 PRM

The Parameter option of the diagnostic program allows the checking and alteration of the Constellation Multiplexer parameters (including Master Multiplexer Configuration table and Polling Parameters) and Drive Parameters (including Spare Track table, Sector Interleaving Specification and Virtual Drive Offset table).

7.3.6.1 MUX

Selecting this option displays the Multiplexer table:

```

M      M
M      M
M      M
M      M
      X
```

As displayed above, the Multiplexer table is not to be altered if the drive is not connected to a Corvus Multiplexer network, or is connected to a single, Host Multiplexer.

Only if a Master Multiplexer is used in the Multiplexer Network is this table to be changed. In the instance that a Master Mux is installed, each of the eight ports (M in the above table) should be changed to either "N" if no device is connected to the port, "C" if a computer other than a DEC-System LSI-11 is connected to the port, or "L" when an LSI-11 is used, or left an "M" if a Host Mux is connected to that port.

There is only one MUX table, and it should be changed to reflect the configuration of the Master Multiplexer only, or left unchanged if only a Host Mux is used.

Polling Parameters is the next option of the program. When the drive is used with a Corvus Multiplexer local network with Intertec Superbrain™ or Radio Shack TRS-80™ computers, the Polling Parameters should be changed:

Standard Polling parameters: 180,16,32,0
For Superbrain and TRS-80: 180,32,32,0

7.3.6.2 DRIVE

Selecting this option displays the Spare Track table, Sector Interleaving Specification, and Virtual Drive Offset table. Whenever a track is found to contain a faulty sector (via the CRC test), that track must be removed from service, and a spare track used. These bad tracks are eliminated by listing them in the Spare Track table. This utility enables the user to:

ADD a track to the Spare Track table (remove it from use)
DELETE a track from the Spare Track table (restore it to use)
LIST the Spare Track table
QUIT or exit from the spare track routine

By selecting the ADD option, the track number returned by the CRC test (see CRC below) can be entered, thereby ignoring the track with the erring sector.

The Sector Interleaving Specification is the next option of the program. Interleaving, or skewing, is defined as the use of an offset constant in the logical numbering of sectors. This value for all B-Series drives is twelve for all computer systems except the DEC System LSI-11 which uses a value of five.

Check the Interleaving Specification when the drive is first received, and whenever it is formatted.

Next, the Virtual Drive Offset table should read:

DRIVE 1 0

unless otherwise instructed by the Corvus "Disk System Installation Guide." This table should be checked when the drive is first received, and whenever the drive is formatted.

7.3.7 SET

This utility allows the user to change the slot number, drive number, or drive type of the drive to be diagnosed. This allows the technician to connect several drives to one host computer, and test any one.

7.3.8 QUIT

Selecting this option exits the program, and returns the user to the main Dealer Service menu.

7.4 Controller Diagnostic

The purpose of the Controller Diagnostic program is to provide comprehensive testing for the Corvus disk drives. Some of these utilities are designed for use when adjusting the servo mechanism on the Corvus 8-inch, 11-megabyte and 20-megabyte disk drives, and will not be used with the 6-megabyte drives. These few utilities are included here only because they are provided on all Dealer Service Diskettes.

7.4.1 General Description:

The Controller Diagnostic program is a combination of Z-80, host system machine code and high-level language programs which allow the technician to directly communicate to the intelligent controller of the disk drive. The code breaks down into three parts as follows:

High-level language terminal program: The high-level portion of the program makes the host computer a semi-intelligent terminal which can communicate with the drive controller. There are several features implemented in the high-level program, such as base conversions, slot selection and the driver which downloads the code to the drive controller.

CHAPTER 8
FAULT ISOLATION PROCEDURES

Host system machine code: The machine code provides the low-level interface to the drive controller. It transmits and receives data from the controller according to the parameters passed to it by the high-level program. It is slot selectable and contains a one second time-out feature which allows the program to recover if the drive is not responding.

Z-80 code: The Z-80 code is the heart of the diagnostic and is the largest portion of the program. It performs the commands which are passed to it by the high-level program via ASCII characters. It consists of three blocks of code which are loaded to different locations in the controller memory.

7.4.2 Controller Diagnostic Commands

The following is a detailed description of each function of the Controller Diagnostic commands. Please note that there should be no spaces in the commands unless the notation <space> is specified.

Whenever the entry of a Controller Diagnostic command results in the response

"x (Y/N)?"

where x is the command entered, be sure the continuation of this test is appropriate; THESE COMMANDS ARE DESTRUCTIVE TO DATA.

During normal operation, when an error is encountered, the controller will repeat the operation in an attempt to succeed. All errors returned by the Controller Diagnostic are reported without retrying the command.

7.4.2.1 A) ABORT DIAGNOSTIC:

This command allows the operator to leave the diagnostic and return to the command level of the operating system. The format for this command is:

A <return>

7.4.2.2 B) MACRO MENU:

This command allows the operator to create a Macro program. The computer will prompt you with:

W)RITE MACRO X)ECUTE MACRO

Enter W to create a Macro program. The format for this command is:

W <return>

The computer will return with the prompt:

ENTER COMMANDS FOLLOWED BY <RETURN>
TO END ENTRY, TYPE 'END' <RETURN>

Enter single-letter Controller Diagnostic commands from this Controller Diagnostic menu, one at a time, each followed by <return>. The Macro list should begin with the DOWNLOAD command and terminate with "END." The computer will then prompt you with:

DATA OK?

Entering a "n" will return the Controller Diagnostic command prompt. Entering a "Y" will result in the computer prompt:

ENTER MACRO FILENAME =>

Enter the name you wish to call the Macro program you have just created (maximum 11 characters). The computer will respond with:

* MACRO FILE WRITTEN TO DISK *

The Macro file can be executed by selecting "X" from the Macro Menu. The computer will prompt you for the filename:

ENTER MACRO FILENAME =>

Enter the filename of the Macro program you have previously created, and press <return>. The Macro program will begin execution:

```
* EXECUTING MACRO ==> xx.MAC *
```

and finish with:

```
* END OF MACRO PROGRAM *
```

A sample Macro program with the name of "TEST" is on the Dealer Service Utilities diskette.

7.4.2.3 C) CHANGE SLOT NUMBER:

This command allows the operator to change the computer slot number of the drive under test. The default value is set to slot 2 at the start of execution. (Note: It is possible to have multiple drives under test by starting execution, then changing slot numbers. You will have to return to the original slot to view test results.) The format for this command is:

```
C<return>
```

The computer will prompt you for the slot number as follows:

```
ENTER SLOT NUMBER (DEFAULT=2) ?
```

Enter the slot number desired and press <return>.

7.4.2.4 D) DOWNLOAD DIAGNOSTIC:

This command must be executed before any of the tests can be performed on the drive. This command loads the Z-80 code into the memory of the drive controller. The FORMAT switch must be on before downloading the diagnostic in order for the program to function correctly. The format for this command is:

```
D<return>
```

7.4.2.5 I) ANALYZE SERVO:

This command is used in the adjustment of the 8-inch disk drive.

7.4.2.6 J) SINGLE DO SEEK:

This command is used in the adjustment of the 8-inch disk drive.

7.4.2.7 L) FULL CYLINDER LOOPSEEK:

This command instructs the controller to continuously seek from cylinder zero to the maximum cylinder. This command can be used to check servo action and to adjust the servo board (8-inch drives only), or as a general servo exercise utility for all drives. The Controller will continue seeking until a new command is issued. The format for this command is:

```
L<return>
```

7.4.2.8 P) PRINT QUIET SUMMARY REPORT:

This command allows the operator to view the results of the sector quiet, seek scan, read scan and write scan commands. The results are printed in the following format:

1) SEEK ERRORS:

Seek errors are represented in the following format:

```
ccc:ddd:ee
```

where ccc is the desired cylinder in decimal, ddd is the cylinder in decimal which was actually found and ee is the error code. See the error codes in section 8.4.3.

2) CRC ERRORS:

CRC errors are represented in the following format:

ccc-h xxxxx

where ccc is the cylinder number in decimal, h is the head number in decimal, and xxxxx is the number of errors in decimal.

3) TOTAL SEEKS:

This number represents the number of seeks the controller has performed so far. The number will be in decimal.

4) SEEK TIME:

This number represents the total time spent performing seeks in milliseconds. The average seek time can be calculated by dividing seek time by the number of seeks.

5) RPM:

These numbers represent the minimum and maximum speed of the drive during the execution of the sector quiet diagnostic.

7.4.2.9 Q) SECTOR QUIET PROGRAM:**CAUTION:**

This command will DESTROY data on the disk.

This command instructs the controller to begin executing the sector quiet diagnostic. This diagnostic is a very comprehensive test of the drive media and electronics. The controller performs continuous seeks, reads and writes at random locations on the disk. The results of this test are obtained by the P command documented in 8.4.2.8. The format of this command is:

Q<return>

The controller will respond with:

Q (Y/N) ?

Enter Y<return> to begin the test, enter N to abort. The controller will continue this test until a new command is issued.

7.4.2.10 S) READ SCAN DISK:

This command instructs the controller to perform a sector verify pass (CRC check). The results of the scan will be added to the sector quiet results which are available thru the command documented in 8.4.2.8. The format for this command is:

S<return>

The controller will continue to read scan the disk until a new command is issued.

7.4.2.11 T) SINGLE CYLINDER SEEK SCAN:

This command instructs the controller to single step across the disk. This can be used to observe the servo tracks on the 8-inch drives as the heads move across the platters. The format of the command is:

T<return>

The controller will continue to seek scan until a new command is issued.

7.4.2.12 X) WRITE SCAN DISK:**CAUTION:****This command will DESTROY data on the disk.**

This command instructs the controller to perform a bottom level format of the drive. This will not write Controller Firmware, it will simply format the entire disk. The format for this command is:

X <return>

The controller will respond with:

X (Y/N) ?

Enter Y to write scan the disk, enter N to abort. The controller will continue to write scan the disk until a new command is issued.

7.4.2.13 Y) REZERO HEADS:

This command instructs the controller to position the heads on cylinder zero. The format for this command is:

Y <return>

7.4.3 Error Codes

The error codes returned by the command documented in 8.4.2.8 are as follows:

- 00 — hardware detected fault in read or write
- 01 — heads move off track while not seeking
- 02 — seek time out
- 03 — phase lock oscillator error (PLO)
- 04 — sector CRC error
- 05 — cylinder address mismatch
- 06 — read after write verify error
- 07 — guard band detected in data region
- 08 — read sector time out
- 09 — write sector time out
- 10 — bad track list overflow
- 11 — sector locate error

7.5 Burn-In Program

THIS PROGRAM IS DESTRUCTIVE TO DATA. Be sure a back-up of the data exists before proceeding.

Selecting the Burn-In program will automatically begin the polling of the host computer slots. The program determines the type of drive in each slot, and the burn-in procedure begins on all drives attached to the host system.

The Burn-In program is a rigorous read-write routine which steps through the drive one chunk (256-sector quantity) at a time, reading and writing specific patterns to each of the sectors. The program divides the disk media into chunks by dividing the total number of sectors by 256.

The Burn-In program begins with the highest chunk number. When the read/write test is completed for the current chunk, a random 256-sector read test is executed over the complete disk drive. When this is complete, the chunk number is decremented by one, and the test repeats.

The program may be halted at any time by pressing the <return> key or the SPACE bar. This displays a sub-menu:

C)ONT L)IST R)ESTART Q)UIT

7.5.1 C)ONT

Entering a "C" will cause the program to continue from where it left off.

7.5.2 L)IST

Entering a "L" will cause the error list to be displayed (for example):

```
*** SLOT NUMBER 2 ****
CURRENT TIME = 0,75
TOTAL ERRORS: 0
HARD ERRORS : 0
SOFT ERRORS  : 0
DO YOU WANT A COMPLETE LIST (Y/N)?
```

Slot number refers to the host slot to which the disk drive is interfaced. Current time refers to A) the pass number and B) the current chunk being tested.

Errors are those disk read or write errors which, after 15 rereads or 3 rewrites, are still in error. Soft errors are those read or write errors which, after at least one retry, have been corrected. Requesting a complete list will result in a display of the specific tracks with the error results for each (refer to section 9.4 for detailed information on error codes).

7.5.3 R)ESTART

Entering an "R" will begin the program again from the beginning. All error counters will be rezeroed.

7.5.4 Q)UIT

Entering a "Q" will return to the Dealer Service Diagnostic menu.

7.6 READ BURN-IN RESULTS

This program allows the burn-in results of all drives to be output to the video display or printer:

```
*** SLOT NUMBER n ***
CURRENT TIME = p,cc
TOTAL ERRORS: x
HARD ERRORS : y
SOFT ERRORS  : z
[followed by a detailed listing of all errors]
```

where n is the number of the slot to which the drive is connected, p is the pass number, cc is the current chunk being tested, and x,y and z are the total errors, hard errors, and soft errors, respectively.

*Radio Shack and TRS-80 are registered trademarks of Tandy Corp.

*Intertec and Superbrain are registered trademarks of Intertec Data Systems, Inc.

CHAPTER 8 FAULT ISOLATION PROCEDURES

8.1 Scope of Chapter

This chapter contains procedures for diagnosing and testing all revisions of the Corvus B-Series 5.25-inch 6MB disk drives. Recommended test equipment is listed, as are error codes. A list of common failures and solutions may be found at the end of this chapter.

8.2 Introduction

The drive is a sophisticated electronic device, and may, at some time, fail. When failure occurs, it may be due to the failure of any of the drive components. The following procedures will aid the technician in isolating the faulty component.

8.3 Tools

The following test equipment is recommended as a minimum for troubleshooting and repair of the Corvus disk drive:

1. Digital voltmeter (± 0.1 percent accuracy), with test leads
2. Host microcomputer: Corvus Concept (256K) or Apple II+ (48K), Corvus Interface PCA and 34-pin flatcable
3. Corvus Dealer Service Diagnostic Utilities diskette (currently these are available for the Corvus Concept and Apple II computers)

8.4 Error Codes

For each command sent to the drive by the host operating system, a single-byte return code is received after the command is executed. It is the responsibility of the operating system to interpret the error code and take appropriate action. All errors reported by the Corvus Diagnostic Utilities are in hexadecimal notation.

Errors returned by the controller are listed below. Errors less than or equal to 127 (decimal) are non-fatal. Those errors greater than or equal to 128 are fatal errors, causing normal drive operation to cease.

The bit format of the error code is shown below:

bit		bit		bit		bit		bit		bit		bit	
7		6		5		4		3		2		1	0

The eight-bit error code is broken into four segments. Bit 7, when set, indicates that the reported error is a fatal error. Bit 6, when set, indicates that the reported error occurred during the verify (read after write) sequence of the write command. Bit 5, when set, indicates that one or more retries were attempted before the error was reported. Bits 0-4 represent one of the 21 codes which describe the error (refer to the error lists in section 8.4.1).

8.4.1 Interpreting Error Codes

As can be seen in the error code tables below, there are up to four different error codes for each error condition. To determine the actual error condition, these procedures should be followed:

1. If the error code value is greater than or equal to 128, a fatal error occurred. Subtract 128 if the value is greater than or equal to 128.
2. If the remaining value is less than 64, the error occurred during a disk read. If the value is greater than or equal to 64, the error occurred during the verify portion of a write command. Subtract 64 if the value is greater than or equal to 64.
3. If the remaining value is less than 32, no retries were attempted. If the value is greater than or equal to 32, at least one retry was attempted before the error was reported.

If no error has occurred, the original error code value of zero will be returned.

Consistent 171 or 235 errors at the same block location indicate bad disk media. Execute the CRC test and follow the instructions for sparing tracks (PRM option, Drive Diagnostics).

Consistent 255 errors indicate that the Controller PCA is not responding to commands sent from the Host Computer, and replacing the Controller may be in order.

Table 8-1. Decimal Disk Error Codes

≤ 127 Non-Fatal					≥ 128 Fatal
32					soft error
	128	160	192	224	error in preparing R/W
	129	161	193	225	seek timeout
	130	162	194	226	seek fault
	131	163	195	227	seek error
	132	164	196	228	header CRC error
	133	165	197	229	rezero timeout
	134	166	198	230	rezero fault
	135	167	199	231	drive not online
	136	168	200	232	write fault
	137	169	201	233	format protected
	138	170	202	234	read fault
	139	171	203	235	data CRC error
	140	172	204	236	sector locate error
	141	173	205	237	write protected
	142	174	206	238	illegal sector address
	143	175	207	239	illegal command op code
	144	176	208	240	spare track table overflow
	145	177	209	241	overlay failure
				254	verify error (burn-in test)
				255	controller timeout (diagnostic utilities)

Table 8-2. Hexidecimal Disk Error Codes

$\leq 7FH$ Non-Fatal		$\geq 80H$ Fatal			
20					soft error
	80	A0	C0	E0	error in preparing R/W
	81	A1	C1	E1	seek timeout
	82	A2	C2	E2	seek fault
	83	A3	C3	E3	seek error
	84	A4	C4	E4	header CRC error
	85	A5	C5	E5	rezero timeout
	86	A6	C6	E6	rezero fault
	87	A7	C7	E7	drive not online
	88	A8	C8	E8	write fault
	89	A9	C9	E9	format protected
	8A	AA	CA	EA	read fault
	8B	AB	CB	EB	data CRC error
	8C	AC	CC	EC	sector locate error
	8D	AD	CD	ED	write protected
	8E	AE	CE	EE	illegal sector address
	8F	AF	CF	EF	illegal command op code
	90	B0	D0	F0	spare track table overflow
	91	B1	D1	F1	overlay failure
				FE	verify error (burn-in test)
				FF	controller timeout (diagnostic utilities)

Table 8-3. Signed Decimal Disk Error Codes

≤ -129 Non-Fatal	≥ -128 Fatal				
-224				soft error	
	-128	-96	-64	-32	error in preparing R/W
	-127	-95	-63	-31	seek timeout
	-126	-94	-62	-30	seek fault
	-125	-93	-61	-29	seek error
	-124	-92	-60	-28	header CRC error
	-123	-91	-59	-27	rezero timeout
	-122	-90	-58	-26	rezero fault
	-121	-89	-57	-25	drive not online
	-120	-88	-56	-24	write fault
	-119	-87	-55	-23	format protected
	-118	-86	-54	-22	read fault
	-117	-85	-53	-21	data CRC error
	-116	-84	-52	-20	sector locate error
	-115	-83	-51	-19	write protected
	-114	-82	-50	-18	illegal sector address
	-113	-81	-49	-17	illegal command op code
	-112	-80	-48	-16	spare track table overflow
	-111	-79	-47	-15	overlay failure
				-2	verify error (burn-in test)
				-1	controller timeout (diagnostic utilities)

8.5 Troubleshooting Procedures

When a disk drive fails to function normally, the problem may range from a faulty sector to total drive failure. It is the responsibility of the service technician to interpret the symptoms, isolate the faulty component, substitute with a replacement, and thoroughly test the drive before returning it to the user.

Corvus provides its Authorized Servicing Dealers with diagnostic utilities and service documentation to aid the technician in servicing Corvus products. The Dealer Service utility diskettes include diagnostics for testing all phases of drive operation. These utilities are described in chapter 7, "Diagnostics."

In using the troubleshooting aids provided, take the following precautions:

1. Make sure all drives have the appropriate version of Controller Firmware.
2. See that the drive has the latest release of controller ROMs.
3. Be sure to disconnect the ac power cord before removing or replacing any modules.
4. Use only known good components when substituting.
5. Retest the system after each component has been substituted.

8.5.1 On-Site Checks

There are several quick checks that can be taken that do not require disassembly of the drive:

1. Be sure the ac power cable is plugged in, and the power switch is turned on.
2. Examine the front bezel switches to verify their proper settings.
3. On the rear bezel, check that the four Mirror DIP-switches are set correctly to reflect the internal Mirror configuration.
4. Check that the CORCOM unit (located on the rear bezel) has the correct line voltage and fuse selected.
5. Verify that the interface cable is not damaged, and has been properly connected at both ends.
6. Check to see that the Interface PCA is in the correct bus slot (where applicable) of the host computer.
7. Check that the drive's Controller Firmware is intact (section 8.5.3.2).

8.5.2 Isolate the Problem

Malfunctions in the Corvus disk system may be divided into four categories:

1. Magnetic, or software (Controller Firmware integrity, data integrity, format integrity, boot image integrity),
2. Physical media damage (imperfections in media surface)
3. Electronic (host computer function, Corvus drive sealed mechanism and associated Read/Write PCA and Logic PCA, Z-80 controller, or power supply)
4. Environmental (power stability, temperature and humidity limits).

The first step in analyzing faults in the Corvus disk system is to isolate the drive from other devices. This includes removing networks (such as the Corvus Multiplexer and OMNINET local networks) and backup devices (such as the Corvus Mirror). Using a known good Interface PCA and flat cable, connect the Corvus disk drive to a known good host computer.

Before any diagnosis of the Corvus disk drive can be carried out, the symptom must be duplicated. If the problem does not reoccur within a reasonable amount of time, run the Burn-In diagnostic program overnight to thoroughly test the drive.

8.5.3 Drive Not READY

In order to utilize the diagnostic software provided, the Corvus disk drive must first be in the READY condition, indicated by the READY LED being lit. Power on the drive and wait approximately 90 seconds. The BUSY and FAULT LEDs will light during power-up but go out. The READY LED alone should be lit, and if this does not occur, steps must be taken to correct it.

8.5.3.1 Interface

The host computer Interface PCA or cable could be defective, not allowing the drive to reach the READY condition. Disconnecting the flatcable from the drive PROCESSOR connector will isolate the drive. If the READY LED now lights, replace the Interface PCA and cable, one at a time, to isolate the faulty module.

8.5.3.2 Controller Firmware

During the normal power-on sequence Controller Firmware is read into the controller RAM. If the Controller Firmware has been disrupted or contains bad blocks, the drive will not be READY after the power-on sequence completes.

To determine if this is the cause of the symptom, turn on the FORMAT switch and toggle the RESET switch. This will reset the Z-80 Controller, and if the drive passes the hardware self-test, will ignore the Controller Firmware. If the READY LED now lights, faulty Controller Firmware is indicated and the UPDATE utility (Chapter 7) must be executed to rewrite the Controller Firmware code. After this has been done, turn off the FORMAT switch and toggle the RESET switch. This again will reset the Z-80 controller which will read the newly-written Controller Firmware into the on-board RAM. The READY LED should now light.

8.5.3.3 Power Supply Voltages

If the fault has been determined to be a drive hardware failure, the first action taken should be to check the power supply voltages.

Check the voltages when the drive is first received, and because of line voltage variations between locations, at the customer site also. If any of the dc output voltages cannot be brought within tolerance, the power supply must be replaced.

Using a Digital Voltmeter, follow the voltage check and adjustment procedures outlined in the Adjustments section of this manual. The dc power connectors (located on the PCA(s) underneath the sealed mechanism and on the backplane) should be checked for a clean and tight fit. Measuring the voltages at the drive Backplane power pins as well as at the power supply will verify that the power connector and cable are in good condition. Inspect the dc power cable, checking for breaks at both ends. The power cable may be faulty if the voltages are not present at the drive Backplane.

Symptoms indicating power supply failure or misadjustment include front bezel LEDs failing to light, drive motor failing to turn or speed fluctuating, and drive going off-line (drive error 255), and CRC errors.

The output of the power supply is a function of the correct ac input; the dc voltages will not be correct if the improper line voltage is selected. To verify that the proper line voltage has been selected, locate the CORCOM unit on the rear bezel of the drive cabinet. This unit contains the fuse and voltage selection PCA. If the voltage is changed, be sure that the line fuse is also changed. Symptoms indicating incorrect line voltage selection include dim or dark LEDs, low motor speed, and extreme heat output.

8.5.3.4 Drive Electronics

If the READY LED will not light, and the power supply is operating properly and the voltages are within tolerance, it is probably due to a faulty component within the drive.

Sometimes symptoms indicating a faulty drive PCA are in fact caused by poor contact between connectors. Power supply connectors, PCA edge connectors, IC sockets and switch contacts are some of the connectors which may lose contact, and result in a malfunctioning drive. Reseating all connectors and using an eraser, clean on all gold edge connector pins to help eliminate any oxidation that may have built up, causing improper contact. Also, reseating socketed ICs on the drive Controller PCA will ensure good pin connections. Toggling all switches (front bezel, rear bezel MIRROR switches, Controller address switches) will insure a clean switch contact.

WARNING:

Always turn off ac power and disconnect power cord before replacing any components.

If the problem still persists, replace the drive controller with a known good unit:

1. Remove power to the drive.
2. Disassemble the drive (chapter 6) and remove the Controller PCA.
3. Install a known good Controller PCA.
4. Power on the drive.

If the controller was faulty, the READY LED will now light. If the READY LED still fails to light, the next step is to replace the drive sealed mechanism with a known good unit.

8.5.3.5 Drive Sealed Mechanism

The drive mechanism is a sealed unit with no field-serviceable parts. Any malfunction of the drive mechanism, or associated Read/ Write PCA and Logic PCA, necessitates replacing the entire drive module.

Drive mechanism failure may be due to any one of the following:

1. Microchip failure
2. Drive motor failure
3. Servo-stepper motor failure

8.5.4 Link Inoperative

If the drive powers on, spins up to speed, passes the self-test and the READY LED lights, certain basic circuits and sub-systems within the drive are working. The test does not, however, verify the integrity of the Disk Operating System (DOS), the disk media or the drive electronics and power supply. If the DOS is damaged or not properly patched for communication to the Corvus disk drive (initialization procedures, Corvus User Guide), the drive will not function properly.

Linking is the process of booting the host computer with the Corvus-patched DOS. The type of DOS depends on the type of computer system, and should be a known good copy, patched for the Corvus drive. For those systems that do not store a DOS image on the Corvus drive and then boot directly from the Corvus (CP/M does not), booting the standard floppy-based DOS and executing the LINK program will establish the patch.

Corvus recommends that Corvus Dealer Service Centers keep on hand archival, known good Corvus-patched copies of the DOS for the specific computers serviced at that location. This will insure that a new DOS copy may be substituted for the users' DOS for troubleshooting purposes.

8.5.4.1 Check Link Action

Boot the computer using a known good boot image or link software. When this has been done, list the directory of the drive or volume. If this fails or a drive error is returned, steps must be taken to correct this.

8.5.4.2 Power Supply

The power supply voltages should be checked and adjusted if necessary before any further testing is done. Without proper voltages, the read amplifier on the Read/Write PCA will be referencing incorrect thresholds for the data signal, possibly mistaking a good sector for a CRC error.

8.5.4.3 CRC Test

Execute the CRC test. This will test the controller's ability to decode drive commands, as well as the stepper motor and read-write electronics. This test will also verify the condition of the drive media. The CRC test will report either no errors or the cylinder, head and sector numbers of the faulty sector. If the CRC errors are encountered, the complete track must be spared (PRM option, drive Diagnostics, Corvus User Guide).

Sometimes the CRC test will not begin (READY LED remains lit) or will not finish (BUSY LED flickers momentarily, and then the READY LED alone lights). A misadjusted power supply or improper format could cause this. Also, a damaged copy of the CRC program could cause problems, making it impossible to trace problems without a known good copy of the utilities.

8.5.4.4 Controller Communication

If the drive does not respond to the CRC test, this may be due to several causes. First, some simple oversight may be the cause (see On-Site Checks, section 8.5.1). Alternately, the controller may not be properly decoding the commands sent from the Host Computer (due to incomplete Controller Firmware resident in RAM, or to a defective component on the Controller PCA), or the drive mechanism itself may have a defective component.

Executing the Controller Diagnostic DOWNLOAD command will attempt to establish communication with the Controller PCA. The diagnostic software will respond with "Programs Loaded To Controller Memory" if this succeeds. Further diagnostic commands should then be executed to determine if the controller is communicating with the drive mechanism. If the diagnostic DOWNLOAD command responds with "Download Aborted" this indicates that the Host Computer and the Controller PCA are not communicating. This could be due to several causes: improper switch selection (FORMAT, MUX, LSI switches, MIRROR switches, Controller PCA switches); defective Interface PCA or cable; defective Controller PCA; defective diagnostic software or incorrect power supply voltages.

8.5.4.5 Servo Action

Once communication with the Controller PCA has been established, drive mechanism performance should be checked. Executing the servo exercise command (Controller Diagnostic LOOPSEEK command) will verify the drive mechanism's ability to seek and read. Fatal errors encountered during this diagnostic command indicate a possible defective drive mechanism.

8.5.4.6 Controller Firmware

If the controller and drive mechanism respond positively at this point, the Controller Firmware should be rewritten and the drive parameters checked (drive Diagnostic utility PARAM) if this has not been done already. The Z-80 controller does not check each block in the Controller Firmware area to check that it is legitimate Controller Firmware code, and will attempt to load it into the on-board RAM and execute it, when the drive is powered on. If the READY LED lights after power-on, this is only an indication that no CRC errors have been encountered. Rewriting firmware is non-destructive to data.

8.5.4.7 Boot ROM

Some computer systems use an auto-boot ROM on the Interface PCA to boot a DOS image from the boot area of the drive. A faulty memory location in this ROM may cause the drive to fail at boot time. Replace only with a tested, known good replacement.

8.5.4.8 Interface Components

A defective Interface PCA or cable may be the cause of problems with the drive. Replace both, only with tested, known good replacements. If the drive works, reinstall the originals one at a time, retesting the drive after each, in order to isolate the particular faulty component.

8.5.4.9 Drive Initialization

Drive initialization (separate from drive format) sets up the disk storage for data and code files used by the host computer system. A boot image, containing the operating system of the host computer system, may also be stored on the drive. Random write commands may corrupt these disk areas, and cause unpredictable data access. Drive format, however, defines the structure of the sector, writing sector information relevant to the controller (sector number, CRC value, etc.). Uncoordinated flux transitions on the disk media may corrupt not only the data, but the sector as well, terminating its ability to retain data.

Corvus provides drive initialization software for each computer operating system (CP/M™, Apple DOS™, UCSD Pascal™, NEWDOS™, IBMDOS™, CCOS™, etc). These utilities initialize the platter surface for accepting a DOS boot image (where applicable) as well as directory and data area.

These areas of the disk, if disturbed either physically or magnetically, will no longer retain the correct information sought by the CATALOG or DIRECTORY listing commands. In this case, the initialization procedures (i.e. PUTGET, PSYSGEN or BSYSGEN) must again be executed to properly initialize the disk surface (refer to the Corvus User Guide for initialization procedures). Since initializing disk directories is DESTRUCTIVE to data, a current backup of the drive data should be kept. Also, be sure to use archival, known good copies of all software whenever initializing the drive.

Any problems persisting at this point lie either with the drive electronics or the disk media. The electronics should be tested, and if the cause of the problem is not found here, the drive should be reinitialized, using a new copy of the software utilities.

8.6 Final Adjustments and Tests

When the faulty module in the drive has been replaced and the problem eliminated, the repair process is only half completed. Final checks and adjustments must be made and the drive tested thoroughly overnight before it may be returned to the user.

8.6.1 CRC Test

The drive media must be verified reliable before the drive can be certified as usable. The CRC test should be executed before and after the drive image is restored (using the Mirror) to check that no sectors have been destroyed. Tracks with faulty sectors should be spared using the PARAM option of the drive Diagnostics.

8.6.2 Install and Test Mirror

If a Corvus Mirror back-up device was part of the original disk system, it should have been removed from the system as one of the first steps in troubleshooting the drive. Having traced and replaced the faulty component in the drive, the Mirror should now be installed and tested. (Refer to the Corvus Mirror Service Manual for procedures on troubleshooting and servicing the Mirror).

8.6.3 CRC Test

Executing the CRC test once again, verifies that elementary communication exists, and that no sectors were accidentally destroyed by restoring a faulty Mirror image.

8.6.4 Power Supply

After troubleshooting procedures have been completed, the power supply voltages must be checked once again before the drive can be tested. This is to insure that the Burn-In test is testing a properly adjusted drive.

8.6.5 Burn-In Test

The Burn-In test is the final endurance test of the drive, revealing any malfunctions as hard or soft errors. This program tests the seeking, reading and writing abilities of all drives connected to the host computer.

The Burn-In test should be run, at a minimum, overnight after all repairs and adjustments on the drive have been completed. If any sectors experience persistent CRC errors, the tracks should be spared (Drive Diagnostic utility PARAM).

™AppleDOS is a registered trademark of Apple Computer, Inc.

™CP/M is a registered trademark of Digital Research, Inc.

™UCSD Pascal is a registered trademark of the Regents of the University of California

™NEWDOS is a registered trademark of Tandy Corporation

™IBMDOS is a registered trademark of IBM Corporation

™CCOS is a registered trademark of Corvus Systems, Inc.

TROUBLESHOOTING FLOW CHART

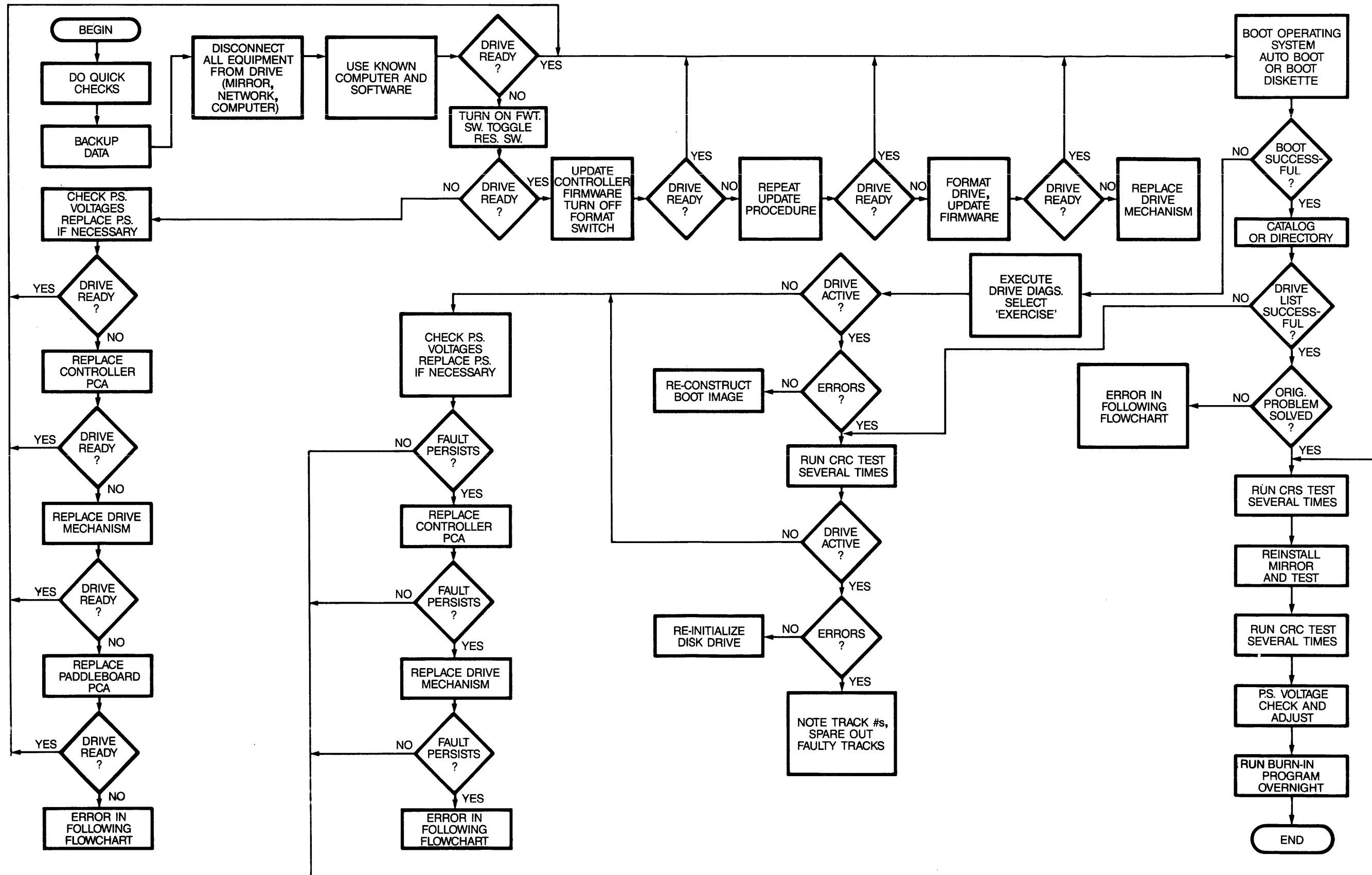

SYMPTOM	CAUSES	RECOMMENDED REPAIR
1. Drive platters won't turn.		
A. All LEDs off and stay off.	ac power improperly selected. +12V misadjusted +12V not present at drive mechanism +12V not existent or not adjustable	Check and adjust. Check voltage and adjust. Check dc power connector for continuity and proper connection at drive Replace power supply
B. All LEDs light then BUSY alone remains lit	Brake solenoid not releasing Drive motor defective	Adjust brake mechanism Replace drive sealed mechanism
2. Unable to format drive		
A. READY remains lit	Mirror switches set wrong Interface card defective Interface cable defective Controller ROMs defective Controller PCB defective Backplane defective	Check and set properly Replace interface card Replace interface cable Replace Controller ROM Replace Controller PCB Replace backplane
B. BUSY remains lit constantly	Controller unit address switches set incorrectly Controller ROMs defective Controller PCA defective Drive mechanism defective	Set switches correctly Replace Controller ROM Replace Controller PCA Replace drive mechanism
3. Unable to update Controller firmware		
A. All LEDs go off, remain off	Drive not ready. Bad track in firmware area HDA Controller PCA defective Drive sealed mechanism defective	Turn on FORMAT switch, toggle RESET switch Replace drive sealed mechanism Replace Controller PCA Replace drive sealed mechanism
B. Busy LED lights and remains lit	Drive format blown Controller ROMs defective Controller PCA defective Drive sealed mechanism defective	Reformat drive Replace Controller ROM Replace Controller PCA Replace drive mechanism

SYMPTOM	CAUSES	RECOMMENDED REPAIR
4. CRC FORMAT CHECK will not begin or finish		
A. Busy LED lights and remains lit, or FAULT LED only remains lit	Front bezel switches incorrect Controller ROMs defective Format not intact Controller PCA defective Drive sealed mechanism defective	Check switch settings Replace Controller ROMs Reformat drive Replace Controller Replace drive mechanism
5. Unable to spare track		
A. All LEDs off and remain off	Controller ROMs defective Controller PCA defective Drive sealed mechanism defective Maximum number of tracks already spared (7 total)	Replace Controller ROM Replace Controller PCA Replace drive mechanism Replace drive mechanism
6. Drive will not execute Servo Exercise under Diagnostic		
A. Busy LED remains lit	Power supply voltages misadjusted Drive sealed mechanism defective	Check voltages, adjust or replace supply as needed Replace drive mechanism
7. Computer boots into monitor (Apple)		
A. Drive goes BUSY, then READY	Boot image corrupted Boot program on Corvus utility diskette corrupt Boot ROM on interface PCA bad Interface PCA defective	Recreate boot image (see Corvus user guide) Recreate boot image using good copy of utilities Replace Boot ROM Replace Interface PCA
8. Drive will not Boot		
A. Busy LED lights and remains lit	Drive does not contain boot image Boot ROM on interface PCA defective Interface PCA defective	Create boot image on drive (see user's manual) Replace Boot ROM Replace Interface PCA

SYMPTOM	CAUSES	RECOMMENDED REPAIR
	Controller ROMs defective	Replace Controller ROM
	Controller PCA defective	Replace Controller PCA
	Drive sealed mechanism defective	Replace drive mechanism
B. READY light remains lit	Mirror switches set incorrectly	Set switches properly
	Front panel switches set incorrectly	Set switches correctly
	Interface board defective	Replace interface board
	Interface cable defective	Replace interface cable
9. I/O errors during normal operation		
A. Normal LED display or all LEDs off and remain off	Software currently running on host system defective	Replace software with known good copy and reexecute
	Boot image corrupted	Recreate boot image (see user's manual)
	Defective track	Execute CRC FORMAT CHECK. Spare any tracks returning errors
	Controller ROMs defective	Replace Controller ROM
	Controller PCA defective	Replace Controller PCA
	Power supply voltages out of tolerance	Adjust power supply
	Power supply voltages fluctuating	Replace power supply
	Drive sealed mechanism defective	Replace drive mechanism
10. Heads slam against inner crash stop (toward hub)		
A. Busy LED lights and remains lit	Controller Firmware corrupted	Update Controller Firmware
	Power supply voltages out of tolerance	Check voltages, adjust if necessary
	Power supply voltages intermittent or can't adjust	Replace supply
	Controller ROMs defective	Replace Controller ROM
	Controller PCA defective	Replace Controller PCA
	Drive sealed mechanism defective	Replace drive mechanism
11. Sector destroyed during normal operation		
A. Busy LED lights and remains lit	Boot ROM (where applicable) or interface board defective	Replace boot ROM. If problem persists, replace Interface PCA

SYMPTOM	CAUSES	RECOMMENDED REPAIR
	ac power surge during read/write operation	Determine quality of ac power supplied to Corvus and host. Determine types of devices on same ac circuit. Large power consuming devices should not share power with the disk drive.
	Power supply voltages out of tolerance	Check and adjust voltages
	Controller PCA defective	Replace Controller PCA
	Weak media spot on platter surface	Determine tracks affected and spare
	Defective drive sealed mechanism	Replace drive mechanism
12. Motor speed varies	+12V out of tolerance	Check and adjust voltage
	dc cable to drive defective	Check wiring, replace supply if bad
	Loose dc connection at drive	Clean connector pins, make sure connector is seated properly
	+12 V non-existent or not adjustable	Replace power supply
	Drive motor defective	Replace drive sealed mechanism
13. Low motor speed	ac input voltage set incorrectly	Check and adjust
	See #12. above	
14. Heads do not rezero		
A. BUSY LED lights and remains lit	Firmware corrupted	Update firmware
	Format corrupted	Reformat drive and update firmware
	Low motor speed	See #12 and 13 above
	Controller unit address set wrong	Set switches correctly
	Controller PCA defective	Replace Contoller PCA
	Drive sealed mechansim defective	Replace drive mechanism
B. FAULT and BUSY LEDs stay on, READY goes off	Controller ROMs defective	Replace Controller ROM
	Controller RAM defective	Replace 4118 RAM on Controller PCA
	Controller PCA defective	Replace Controller PCA
C. All LEDs stay off	Incorrect ac power setting	Check and adjust
	Power supply voltages incorrect	Adjust or replace supply as necessary
	Defective Controller ROMs	Replace Controller ROM
	Defective Controller PCA	Replace Controller PCA

SYMPTOM	CAUSES	RECOMMENDED REPAIR
	Paddleboard cable connected wrong	Check paddleboard cable connections
	Defective paddleboard	Replace paddleboard
	Defective paddleboard cable	Replace cable
	Defective drive sealed mechanism	Replace drive mechanism
	Defective backplane	Replace backplane
D. All LEDs stay on	Power supply voltages incorrect	Adjust or replace supply as necessary
	Defective Controller PCA	Replace Controller PCA
	Defective drive sealed mechanism	Replace drive mechanism
15. Head oscillates after drive is turned on		
A. BUSY LED lights and remains on	Controller Firmware corrupted	Update firmware
	Format corrupted	Reformat and update firmware
	Power supply voltages incorrect	Adjust power supply
	Power supply defective	Replace power supply
	Controller PCA defective	Replace Controller PCA
	Drive sealed mechanism defective	Replace drive mechanism

APPENDIX A
GLOSSARY

GLOSSARY

BACKPLANE OR MOTHERBOARD: two-slot printed circuit board which accepts the Mirror PCA (when installed) and Controller PCA.

BIT: single binary digit. Smallest representative unit of data, several of which make up characters (A-Z, 0-9, etc.). Bits may be either a one or a zero, on or off, set or reset. This may be shown by either a signal being present or not, or by a signal changing states or being constant.

BLOCK: a relative quantity of data bytes. The Corvus disk defines one block to contain 512 bytes of data, the smallest addressable unit within the drive. The host operating system may define a block as 128, 256 or 512 bytes in length. Externally, since the disk drive handles data in sectors, no apparent conflict appears to the host system.

BRAKE OR SOLENOID BRAKE: immediately after power-down, this mechanism engages, so as to minimize contact time between heads and disk surface, and brings the platters to a stop.

BYTE: any multi-bit digital value, usually eight bits long. The Corvus disk drives use eight-bit bytes.

CABINET OR ENCLOSURE: the cabinet which contains the IMI drive mechanism, power supply and fan. The front bezel attaches to the cabinet basepan. Two screws at the rear of the cabinet secure the cabinet top to the basepan.

CONTROLLER OR Z-80 CONTROLLER OR INTELLIGENT CONTROLLER: the disk controller circuitry including the Z-80 microprocessor and support logic.

CORCOM: the rear bezel unit which accepts the power cord, and contains the line filter, line voltage PCB and fuse.

CYLINDER: all data tracks in common vertical alignment. There are 306 concentric cylinders on all H-series drives. The Model 6 has two tracks per cylinder, the Model 11 has four, and the Model 20 has 6.

DISK MECHANISM OR SEALED MECHANISM: the IMI disk drive assembly consisting of platters, drive motor, head assembly and stepper-motor mechanism, all in a sealed, cast aluminum body. The above components inside the sealed mechanism are not field-servicable and the unit is not to be opened by any other than a Corvus factory facility, otherwise the warranty will be void.

DMA OR DIRECT MEMORY ACCESS: method by which data is transferred at a very high rate, independent of the processor. The processor is put into a "wait" state, where it does no data manipulation. The DMA circuitry takes care of all details, using the Z-80 address bus for destination or origin address for data transfer.

DVM: Digital Volt Meter. A meter used for measuring voltages, which shows output by means of a display consisting of changing digits, proportional to the voltage measured.

FIRMWARE or CONTROLLER FIRMWARE: Z-80 code contained in the first two cylinders of the drive consisting of routines for the Spare Track Table, Virtual Drive Offset table, Pipes, and Semaphore Status Flags. The appropriate routines are downloaded from the Firmware into the on-board RAM for execution by the Z-80 Controller at power-on time.

FRONT BEZEL: the front panel of the cabinet, containing the Paddleboard PCA and logo.

GROUNDSTRAP: located at the lower end of the spindle in the drive sealed mechanism, the groundstrap consists of a copper metal strip terminating with a carbon button which rides on the spindle end. This device discharges any static charge which may build up on the platters or spindle.

HEAD: in the Winchester disk, very low-mass glass-ferrite, aerodynamic-shaped component, containing a wire winding. There is one head for each data surface which float 18 microns above the platters on a cushion of air. When current passes through the winding, an electromagnetic flux is induced into the platter surface representing a bit.

HEADSTACK: casting to which all heads are attached. Located in the top of the headstack is the microchip responsible for head selection and signal buffering.

IC: Integrated Circuit. A hybrid, densely populated wafer of silicon containing many resistors and transistors.

CORVUS DEALER SERVICE

MEGABYTE: one million bytes.

MFM (MODIFIED FREQUENCY MODULATION): a method of writing information on a magnetic surface which allows a higher bit density to be used, therefore increasing storage capacity while decreasing size.

MOTOR CONTROL PCA: printed circuit board responsible for monitoring the spindle motor speed and adjusting this as necessary.

NRZ (NON-RETURN TO ZERO): digital representation of information used by microprocessors.

PADDLEBOARD: the small PCA located on the front bezel, which contains the three LEDs and four function switches.

PCA: Printed Circuit Assembly. The Printed Circuit Board, assembled with all its components.

PCB: Printed Circuit Board. Epoxy board with a copper circuit etched onto it. The PCB is the bare board without the usual components such as resistors, transistors and integrated circuits.

PLATTER: circular disks coated with a magnetic oxide that will retain a magnetic flux induced by the read/write heads. Both surfaces of each platter contain data. The 10-megabyte drive has two platters, while the 20-megabyte has three.

REAR BEZEL: the rear most panel area of the cabinet, containing the flatcable connectors for the interface cable, video connectors, power cable and fuse holder. Serial number is located on the rear bezel, also.

SECTOR: each track is divided radially into 20 segments. Each segment is one sector, and contains one block of data, one CRC value, and header information required by the disk controller.

SINUSOIDAL WAVE: a wave form that represents periodic oscillations.

TRACK: all points on one surface with the same radius. Tracks are configured concentrically on each surface.

WINCHESTER TECHNOLOGY: a unique design first developed by IBM as a means to reduce the size of a disk drive while increasing its capacity and removing the possibility of contamination of the disk components. The result was a disk unit much smaller than the traditional 14-inch disk platters with equivalent capacity. This is due to new head design and the use of the sealed-environment used with the disk drive which does not allow the external atmosphere inside the disk mechanism. Inherent in this design is heads that rest on the platters after the drive is powered off. The Corvus disk system uses International Memories Incorporated (IMI) Winchester disk drives.

READ/WRITE PCA: the printed circuit assembly responsible for changing the data received from the heads in MFm format and amplifying and shaping the data signal before passing it on to the Controller circuitry for manipulation.

APPENDIX B
PARTS LIST FOR B-SERIES 6MB DRIVES

APPENDIX B
PARTS LIST FOR B-SERIES 6MB DRIVES

PART NUMBER	DESCRIPTION
2200-01669	6MB DRIVE MECHANISM (REV B - E)
2200-01668	CONTROLLER PCA (REV B - E)
3100-02072	TOP COVER ONLY, REV D, E (GREY PLASTIC)
3100-02073	BOTTOM PAN ONLY, REV E (GREY PLASTIC)
8010-08109	FRONT BEZEL, REV A, B
3100-0271	FRONT BEZEL, REV D, E
2400-01527	DRIVE SUPPORT BRACKET/SHIELD, REV C - E
2600-01143	FAN, REV A, B
2600-01145	FAN, REV C - E
2600-04138	AC CORD FOR FAN, REV A, B
6000-01438	AC CORD FOR FAN, REV C - E
3010-08026	PCA MIRROR
4000-01667	CP134 POWER SUPPLY, REV A
8010-08629	HB5 POWER SUPPLY, REV A
8010-08060	CP417 POWER SUPPLY, REV B - E
6010-01447	AC LINE CORD
8010-08029	PADDLEBOARD PCA
8010-08040	FLATCABLE, PADDLEBOARD - BACKPLANE
8010-08042	FLATCABLE, INTERFACE (5FT)
8010-08108	BACKPLANE PCA, ASSEMBLY
8010-08063	DC HARNESS
8010-08050	AC HARNESS (POWER SWITCH, CORCOM)

APPENDIX C
B-SERIES 6-MEGABYTE CABLING CHART

APPENDIX C B-SERIES 6-MEGABYTE CABLING CHART

The following references of "left" and "right" are as seen from the front of the fully assembled drive cabinet.

REVISION A DRIVE

Flatcables:

- Mechanism-to-backplane (34-pin)
 - Mechanism: one-edge forward
 - Backplane: one-edge to the left
- Paddleboard-to-backplane (34-pin)
 - Paddleboard: one-edge down
 - Backplane: one-edge to the left
- Backplane-to-host interface (34-pin)
 - Backplane: one-edge to the left
 - Host interface: refer to the Installation Guide

Dc Power Cables:

- Drive mechanism (4-wire):
 - Black wire forward
- To Backplane (5-wire):
 - Red wire to the left

REVISION B - E DRIVES

Flatcables:

- Mechanism-to-controller (26-pin)
 - Mechanism: one-edge to the rear
 - Controller: one-edge to the left
- Paddleboard-to-backplane (20-pin)
 - Paddleboard: one-edge down
 - Backplane: one-edge to the left
- Backplane-to-host interface (34-pin)
 - Backplane: one-edge to the left
 - Host interface: refer to the Installation Guide

Dc Power Cables:

- Drive mechanism (5-wire):
 - Red wire forward

R E V I S I O N				
PCO NO	REV	DESCRIPTION	APPROVED	DATE
147	A	REL FOR PROD	<i>[Signature]</i>	7-2-81

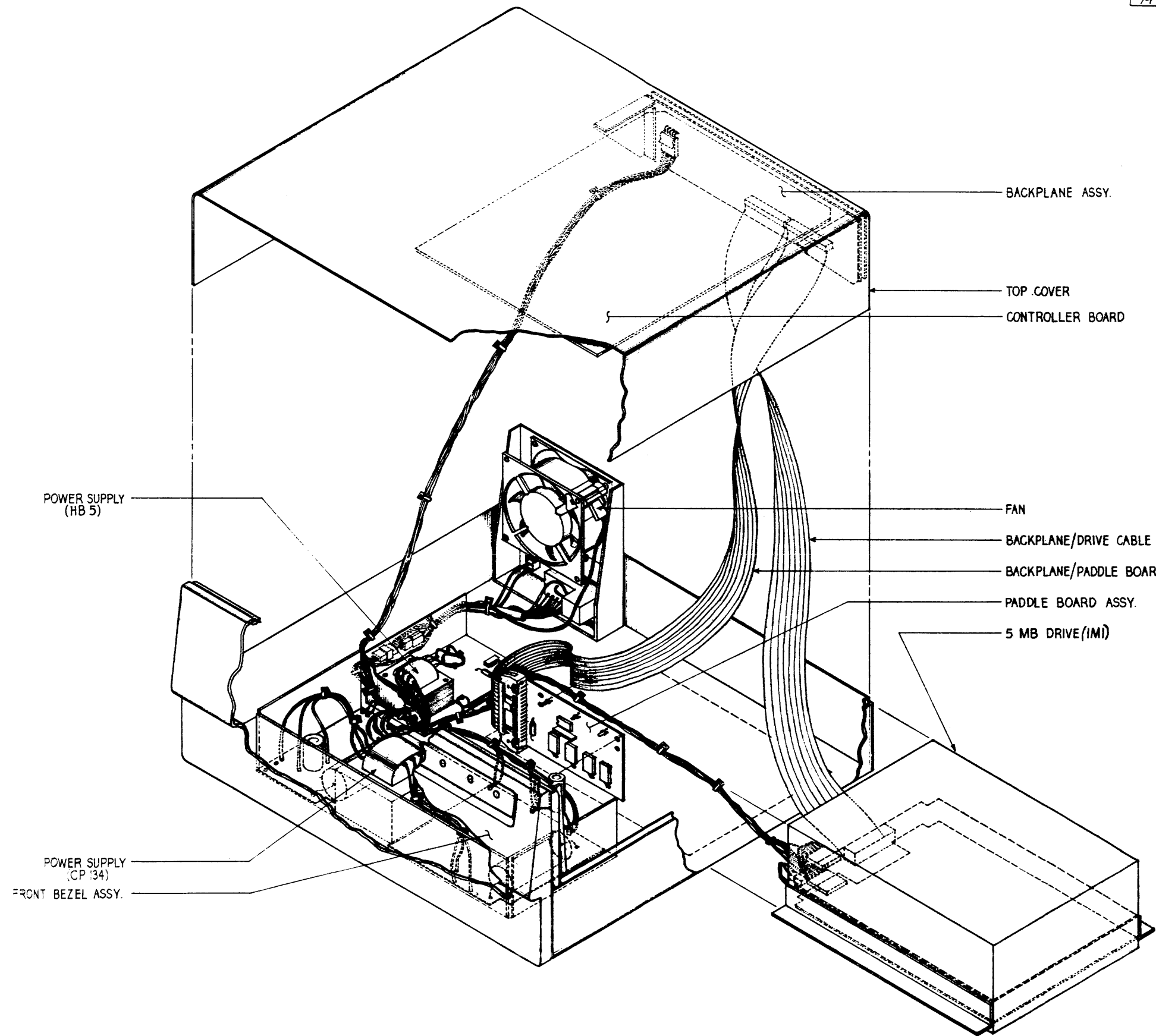

CORVUS SYSTEMS, INC.			
DATE: NONE	DESIGNED BY: CRD	DATE: 6-30-81	REV: A
DRAWN BY: <i>[Signature]</i>		CHECKED BY: <i>[Signature]</i>	
6 MB TOP ASSY. PHASE I			
ASSY. DRAWING			8000-06009

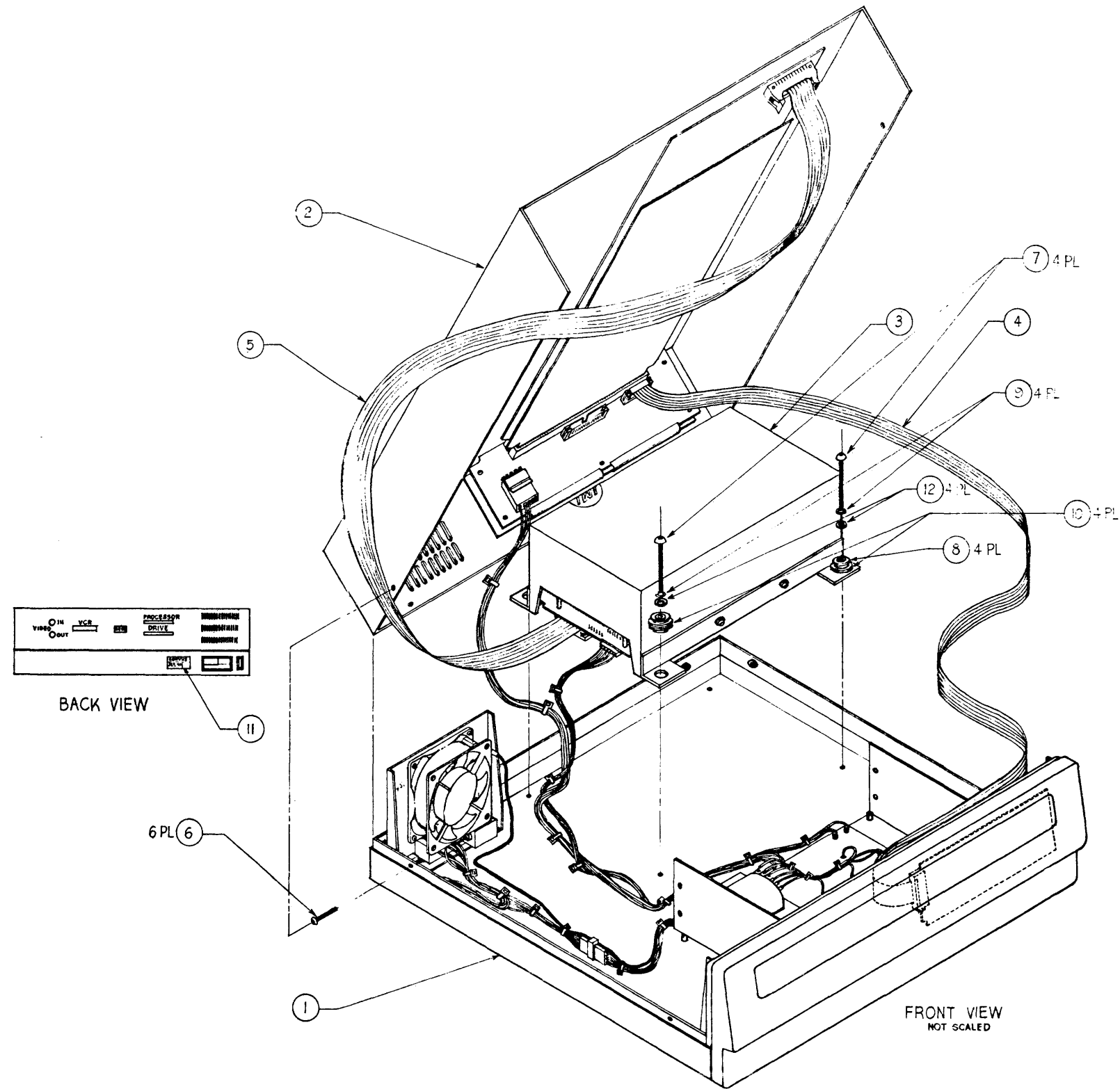

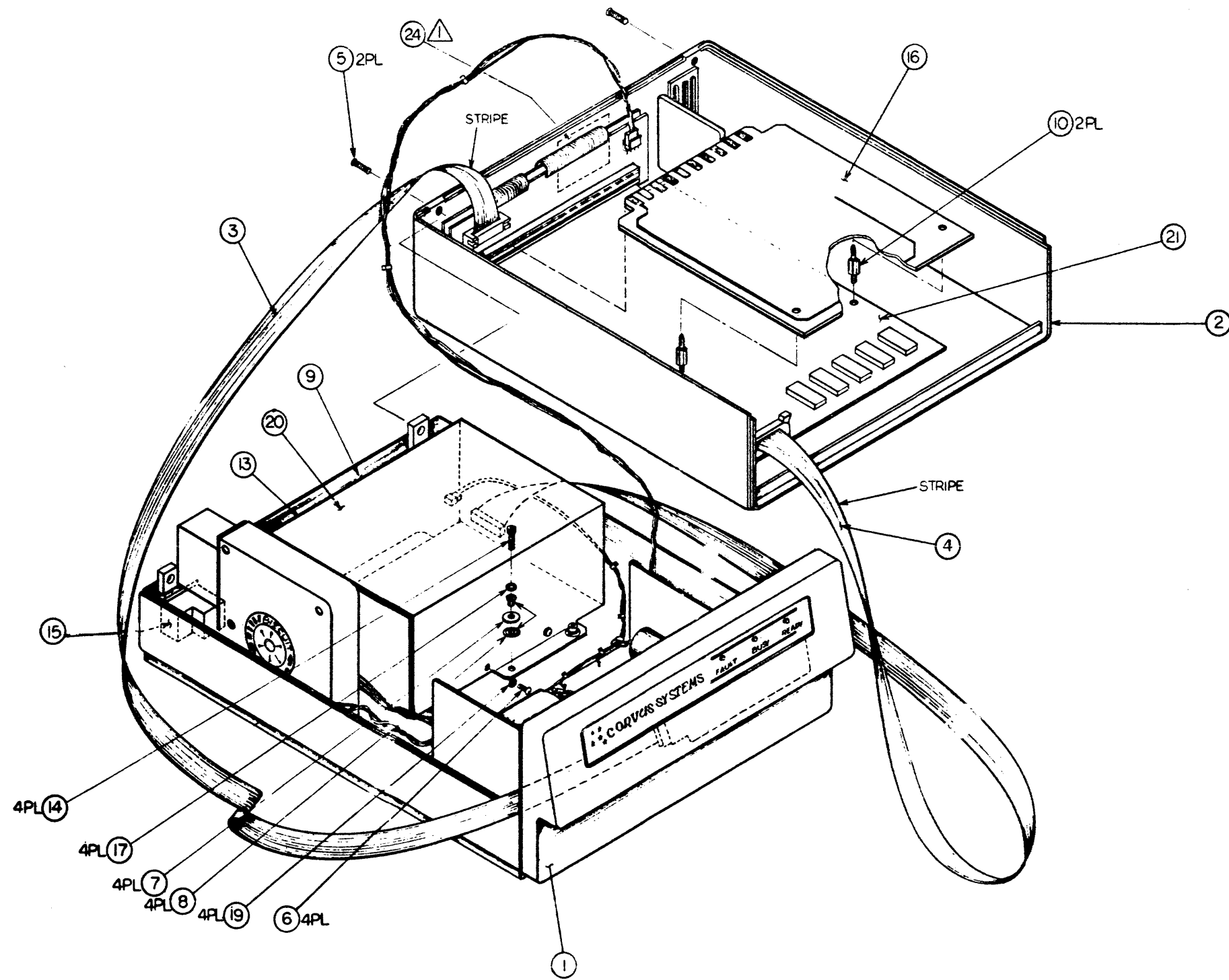

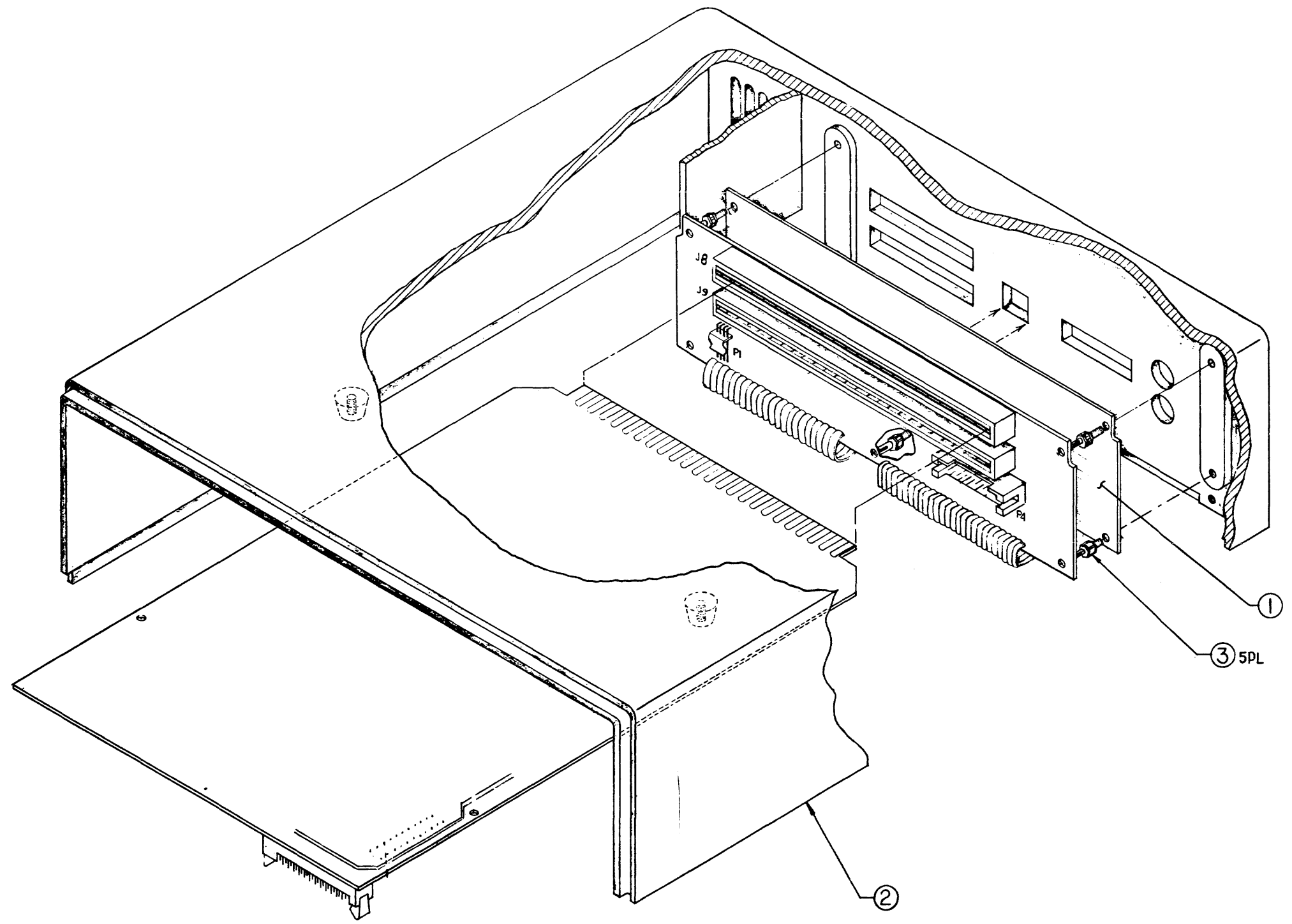

APPENDIX D
ASSEMBLY AND SCHEMATIC DRAWINGS

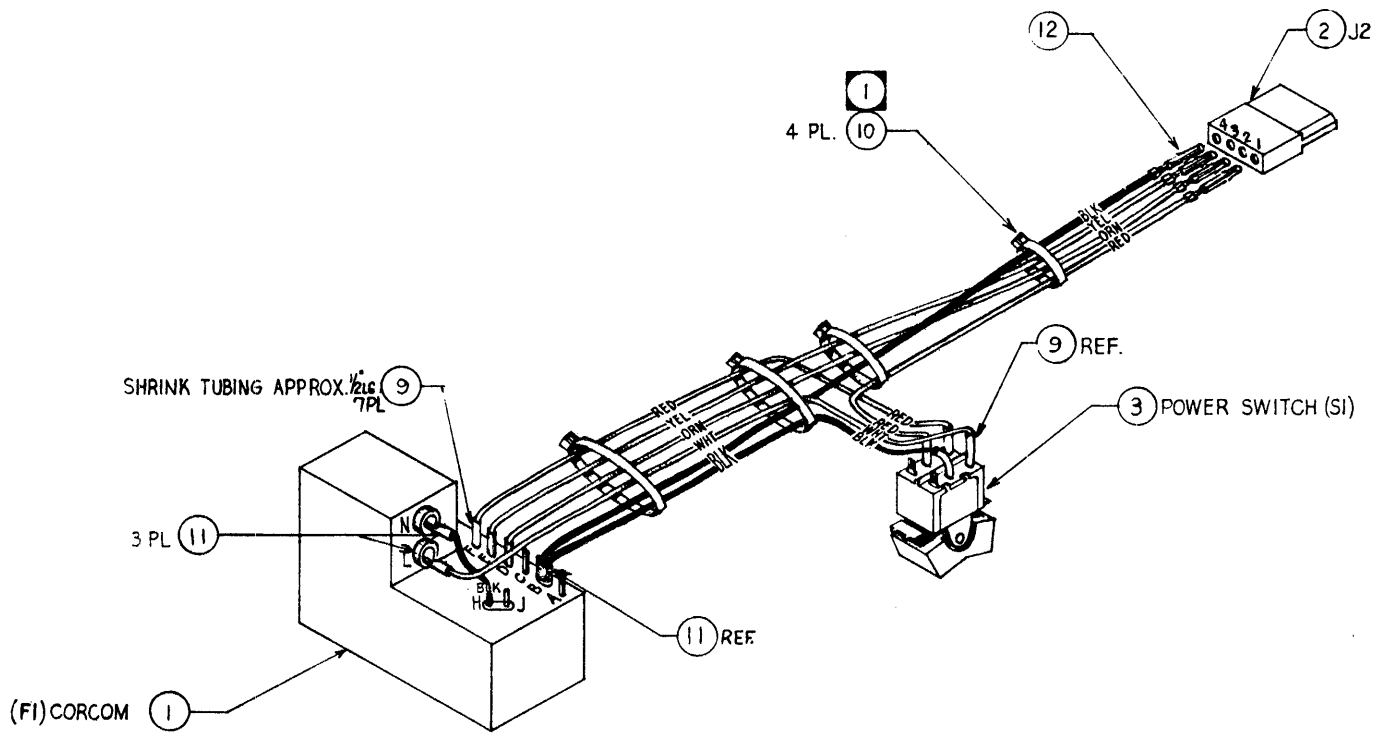

NOTE: UNLESS OTHERWISE SPECIFIED.

1. SHOWN OPEN TIE WRAPS FOR CLARITY ONLY.
WRAPS SHOULD BE PULLED TIGHTLY.

Microcomputer Power, Inc.

2272 Calle de Luna, Santa Clara, CA 95050

(408) 988-0265

TWX 910 338-7694



APPLICATION DATA INCLUDING:

1. SCHEMATIC
2. PARTS LIST
3. SPECIFICATION
4. OUTLINE & MOUNTING DRAWING

MODEL

CP134

MICRO/DISK
SERIES

SPECIFICATIONS:

AC INPUT: 115/230VAC $\pm 10\%$
47-63Hz

DC OUTPUT:

VOLTAGE	CURRENT (AMPS)
5	6.0
12	3.4
-12 OR*	0.5 OR*
-5	0.25

*JUMPER SELECTABLE ON P.C. BOARD

LINE REGULATION: $\pm 0.05\%$ FOR A 10%
LINE CHANGE

LOAD REGULATION: $\pm 0.05\%$ FOR A 50%
LOAD CHANGE

OUTPUT RIPPLE: 3mV Pk-Pk MAX

TRANSIENT RESPONSE: 30 μ SECONDS
FOR A 50% LOAD CHANGE

OVERLOAD AND SHORT CIRCUIT PROTECTION:
AUTOMATIC CURRENT LIMIT/
FOLDBACK

OVER VOLTAGE PROTECTION: SET AT 6.2
 ± 0.4 VDC ON +5V ONLY

STABILITY: $\pm 0.3\%$ FOR 24HRS AFTER WARM-UP

INPUT FUSING: RECOMMENDED, FUSE AT

4A FOR 115VAC, 2A FOR 230VAC

TEMPERATURE COEFFICIENT: $\pm 0.03\%$ /°C MAX

COOLING: UNITS ARE FULL RATED TO 50°C
IN FREE AIR, MUST BE FAN
COOLED WHEN MOUNTED IN CON-

FINED AREA

TEMPERATURE RATING:

0-50°C - 100%

60°C - 60%

70°C - 40%

EFFICIENCY: COMBINED EFFICIENCY

APPROX. 55% @ 115VAC FULL

LOAD ON ALL OUTPUTS

CONSTRUCTION: ALL ALUMINUM CHASSIS

WEIGHT: 8LBS (3.6KG)

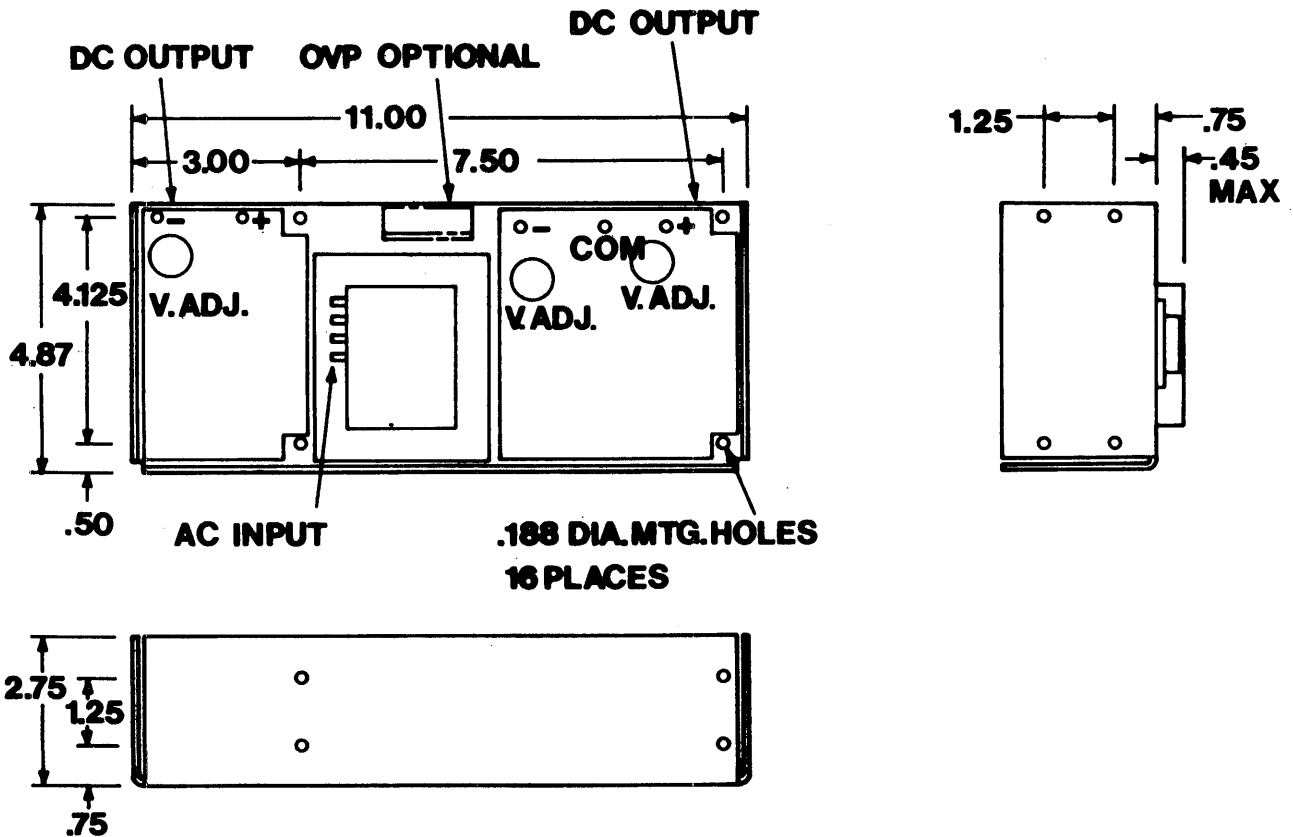

REF. DES.	C5-6/OVP		DESCRIPTION
C1	16000/15V		CAPACITOR, ELECTROLYTTIC
C2,4	1000/16V		CAPACITOR, FILM
C3	.001/100V		RECTIFIER, 6A 100V
CR1,2	MR751		RECTIFIER, 1A 200V
CR3,4	AE1C		ZENER DIODE, 300MW
CR5	1N752A		
R1,2	6.8		RESISTOR, 1/2W CF 5%
R3	47		
R4	1.5K		
R6	2.2K		
R7	3.9		
R8	1.1K		
R5	1500		
Q1,2	2N3055		
SCR1	S0308LS3		TRANSISTOR, POWER NPN
U1	UA723C		SCR, 8A 30V
T1	10101		I.C. VOLTAGE REGULATOR
P.C.B.	10005		TRANSFORMER
CHASSIS	10081		PRINTED CIRCUIT BOARD
			ALUMINUM, ANODIAED

TRANSFORMER CONNECTION DIAGRAM

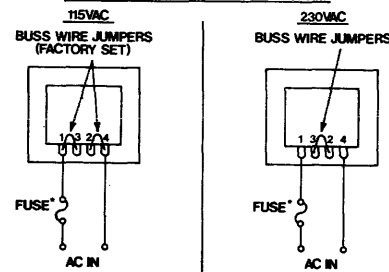

*SEE INPUT FUSING RATING FOR RECOMMENDED FUSE.

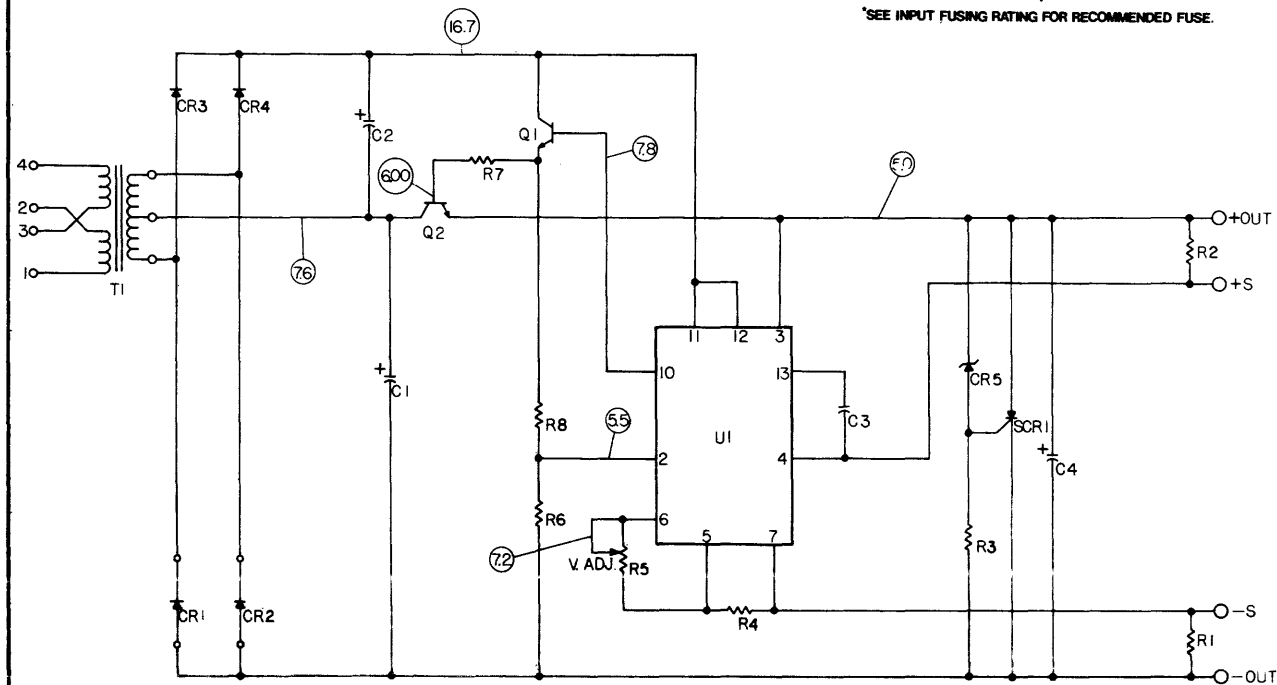

NOTES:

- VOLTAGE MEASUREMENTS AT 115 VAC INPUT FULL LOAD ON OUTPUT.
- ALL VOLTAGES REFERENCED TO NEG. OUTPUT.
- 5.0 DENOTES 5V UNIT.

REF. DES.	C5-6/OVP		DESCRIPTION
C1	16000/15V		CAPACITOR, ELECTROLYTTIC
C2,4	1000/16V		CAPACITOR, FILM
C3	.001/100V		RECTIFIER, 6A 100V
CR1,2	MR751		RECTIFIER, 1A 200V
CR3,4	AE1C		ZENER DIODE, 300MW
CR5	1N752A		
R1,2	6.8		RESISTOR, 1/2W CF 5%
R3	47		
R4	1.5K		
R6	2.2K		
R7	3.9		
R8	1.1K		
R5	1500		
Q1,2	2N3055		
SCR1	S0308LS3		TRANSISTOR, POWER NPN
U1	UA723C		SCR, 8A 30V
T1	10101		I.C. VOLTAGE REGULATOR
P.C.B.	10005		TRANSFORMER
CHASSIS	10081		PRINTED CIRCUIT BOARD
			ALUMINUM, ANODIAED

TRANSFORMER CONNECTION DIAGRAM

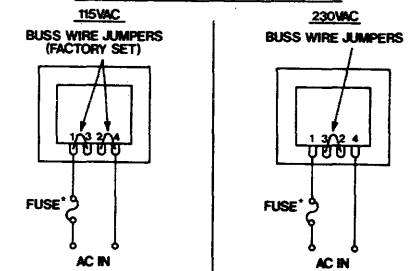

*SEE INPUT FUSING RATING FOR RECOMMENDED FUSE.

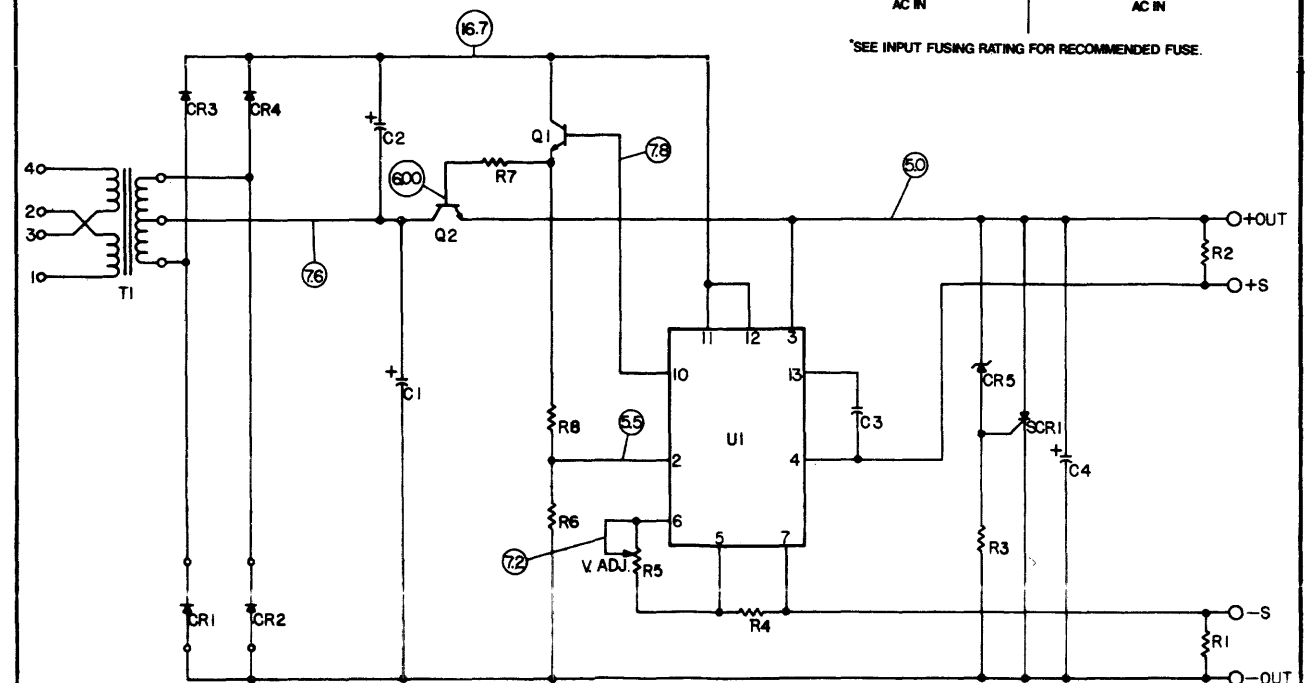

NOTES:

- VOLTAGE MEASUREMENTS AT 115 VAC INPUT FULL LOAD ON OUTPUT.
- ALL VOLTAGES REFERENCED TO NEG. OUTPUT.
- 5.0 DENOTES 5V UNIT.

Microcomputer Power, Inc.

2272 Calle de Luna, Santa Clara, CA 95050
 (408) 988-0265 TWX 910 338-7884



APPLICATION DATA INCLUDING:

1. SCHEMATIC
2. PARTS LIST
3. SPECIFICATION
4. OUTLINE & MOUNTING DRAWING

MODEL

C5-6/OVP

SPECIFICATIONS:

AC INPUT: 115/230VAC $\pm 10\%$
47-63Hz

DC OUTPUT: 5VDC AT 6.0AMPS

LINE REGULATION: $\pm .05\%$ FOR A 10%
LINE CHANGE

LOAD REGULATION: $\pm .05\%$ FOR A 50%
LOAD CHANGE

OUTPUT RIPPLE: 3mV Pk-Pk MAX

TRANSIENT RESPONSE: 30 μ SECONDS
FOR A 50% LOAD CHANGE

OVERLOAD AND SHORT CIRCUIT PROTECTION:
AUTOMATIC CURRENT LIMIT/
FOLDBACK

OVER VOLTAGE PROTECTION: SET AT
6.2 \pm .4VDC

STABILITY: $\pm .3\%$ FOR 24HRS AFTER WARM -UP

INPUT FUSING: RECOMMENDED, FUSE AT
2A FOR 115VAC, 1A FOR 230VAC

TEMPERATURE COEFFICIENT: $\pm .03\%/^{\circ}\text{C}$ MAX

COOLING: UNITS ARE FULL RATED TO 50 $^{\circ}\text{C}$
IN FREE AIR, MUST BE FAN
COOLED WHEN MOUNTED IN CON-
FINED AREA

TEMPERATURE RATING:
0-50 $^{\circ}\text{C}$ - 100%

60 $^{\circ}\text{C}$ - 60%

70 $^{\circ}\text{C}$ - 40%

EFFICIENCY: AT 115VAC, FULL LOAD ON
OUTPUT - 45%

CONSTRUCTION: ALL ALUMINUM CHASSIS
WEIGHT: 4LBS (1.8KG)

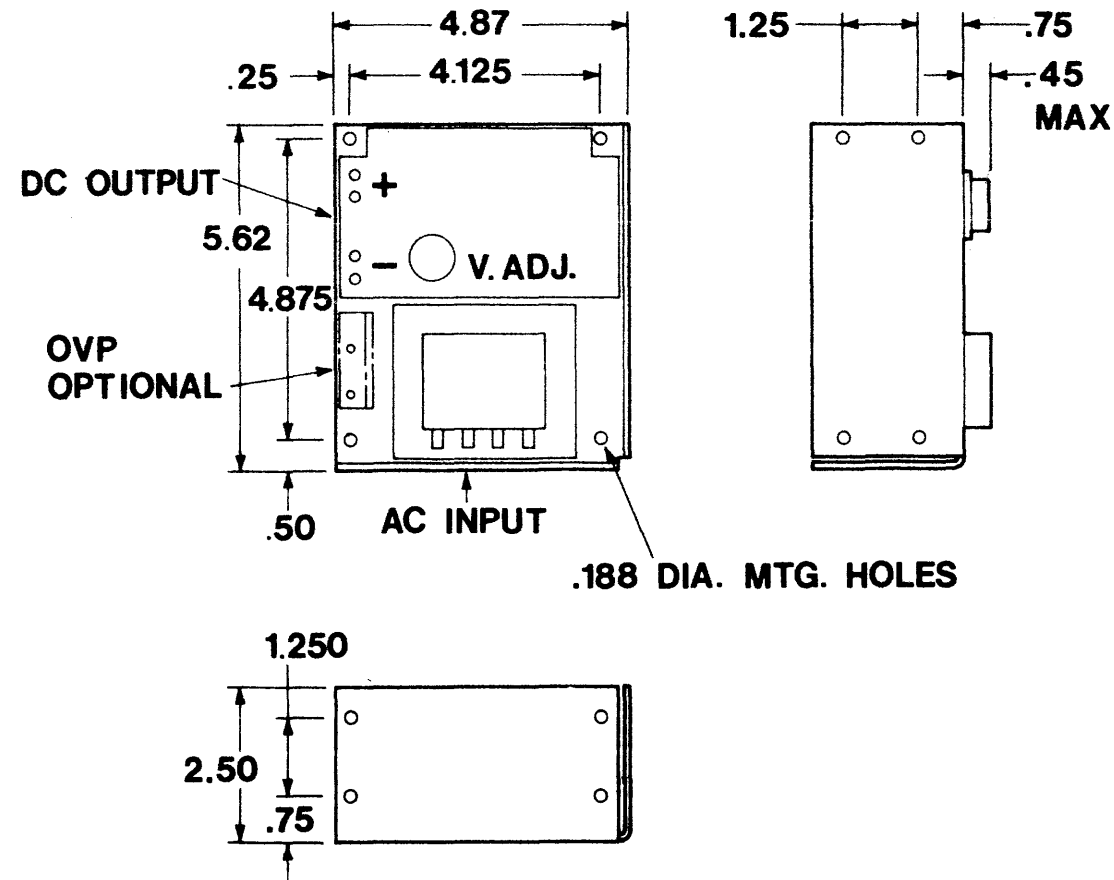

REF. DES.	CP134	CP135	CP136	DESCRIPTION
C1	7300/35V	7300/35V	7300/35V	CAPACITOR, ELECTROLYTIC
C4,5	470/35V	470/35V	470/35V	
C7	100/35V	100/35V	100/35V	
C3,6	.001/100V	.001/100V	.001/100V	CAPACITOR, FILM
CR1,2	AE1C	AE1C	AE1C	RECTIFIER, 1A 200V
CR3,4	MR751	MR751	MR751	RECTIFIER, 6A 100V
CR5,5	-	-	-	ZENER DIODE, 300MW
R1,2,5	330	330	330	RESISTOR, 1/2W CF 5%
R10,11,16	330	330	330	
R3,4	1	1	1	
R6,7	2.2K	2.2K	2.2K	
R9,13	-	-	-	
R12,18	1.1K	1.1K	1.1K	RESISTOR, 2W W ³
R17	4.7K	4.7K	4.7K	
R14,15	.12	.12	.12	POTENTIOMETER, 2W WW
R8,19	1500	1500	1500	TRANSISTOR, POWER NPN
Q1,4	2N3055	2N3055	2N3055	TRANSISTOR, SIGNAL PNP
Q2	2N2905A	2N2905A	2N2905A	TRANSISTOR, POWER NPN
Q3	TIP31A	TIP31A	TIP31A	SCR, 3A 30V
SCR1,2	-	-	-	I.C. VOLTAGE REGULATOR
U1,2	UA723C	UA723C	UA723C	TRANSFORMER
T1	10333	10334	10335	PRINTED CIRCUIT BOARD
P.C.B.	10324	10324	10324	ALUMINUM, ANODIZED
CHASSIS	10088	10091	10089	

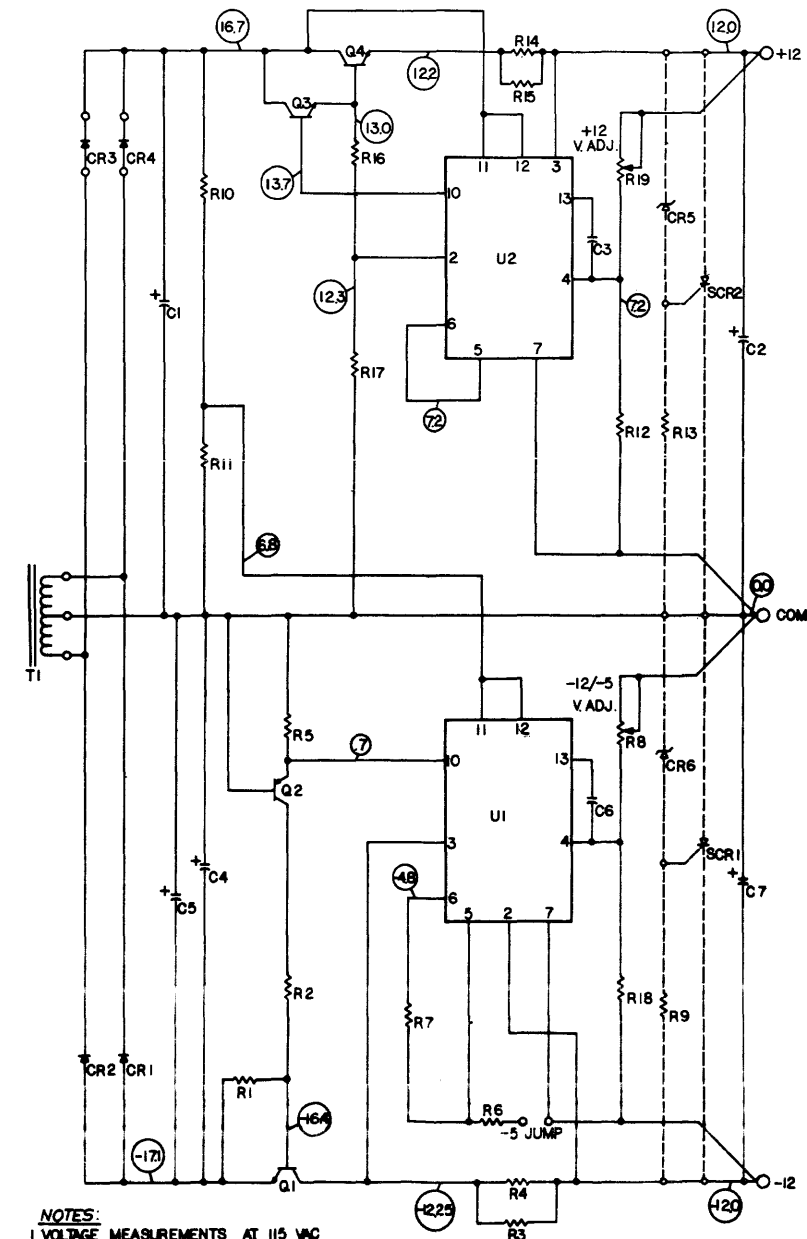

NOTES:
 1. VOLTAGE MEASUREMENTS AT 115 VAC
 INPUT FULL LOAD ON OUTPUT.
 2. ALL VOLTAGES REFERENCED TO COM. OUTPUT.

This drawing and specifications, herein, are the property of POWER-ONE INC. and shall not be reproduced or copied or used in whole or in part as the basis for the manufacture or sale of items without written permission.

REVISIONS				
ECO	LTR	DESCRIPTION	DATE	APPROVED
	A	PROD RELEASE	3-9-81	K.C.
5208	B	INC ECO	7-1-81	

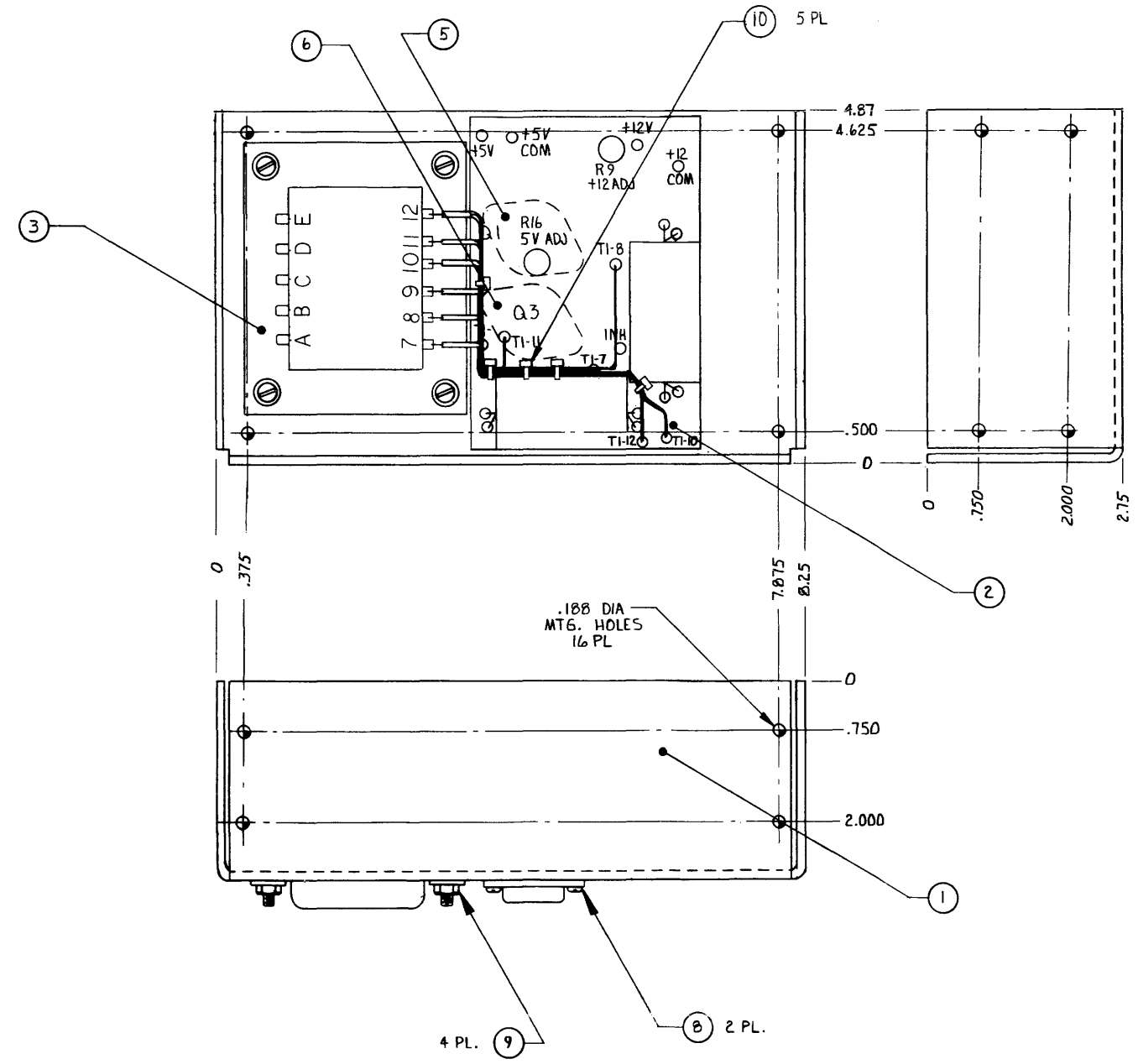

QTY REQD	ITEM	PART OR IDENTIFYING NO.	NOMENCLATURE OR DESCRIPTION	POWER-ONE STD. P/N
5	10		TY WRAP	316-10440
4	9	6-32	NUT, KEP	340-10602
2	8		MTG KIT, T0-3	088-20130
	7			
1	6	2N6055	TRANSISTOR T0-3	171-10263
1	5	2N3771	TRANSISTOR T0-3	171-10245
	4			
1	3		TRANSFORMER	082-19259
1	2		PRINTED CIRCUIT BOARD	081-19267
1	1		CHASSIS	412-19464

TOLERANCE .XX = .030 .XXX = .010		CONTRACT NO.		CAMARILLO, CALIF. 93010 (805) 484-2886	
APPROVALS		DATE		TITLE	
DRAWN <i>Jim Johnson</i>		1-20-81		ASSEMBLY	
CHECKED <i>[Signature]</i>		3-9-81			
ENG. APP. <i>[Signature]</i>		3-9-81			
APPROVED					
FINISH		SIZE		CODE IDENT NO.	
CP 417		D		54407	
NEXT ASSY		DRAWING NO.		REV	
USED ON		19263		B	
APPLICATION		DO NOT SCALE DRAWING		SCALE 1/8" = 1"	
				SHEET 1 OF 1	

NOTES: UNLESS OTHERWISE SPECIFIED

This drawing and specifications, herein, are the property of POWER-ONE INC. and shall not be reproduced or copied or used in whole or in part as the basis for the manufacture or sale of items without written permission.

REVISIONS				
ECO	LTR	DESCRIPTION	DATE	APPROVED
	A	PROD RELEASE	3-9-81	FL
6300	B	ADDED & MOVED PRODUCTION NOTES	2-22-82	FL
7016	C	CHANGED PART NUMBER & VALUE ON R20	6-22-82	FL

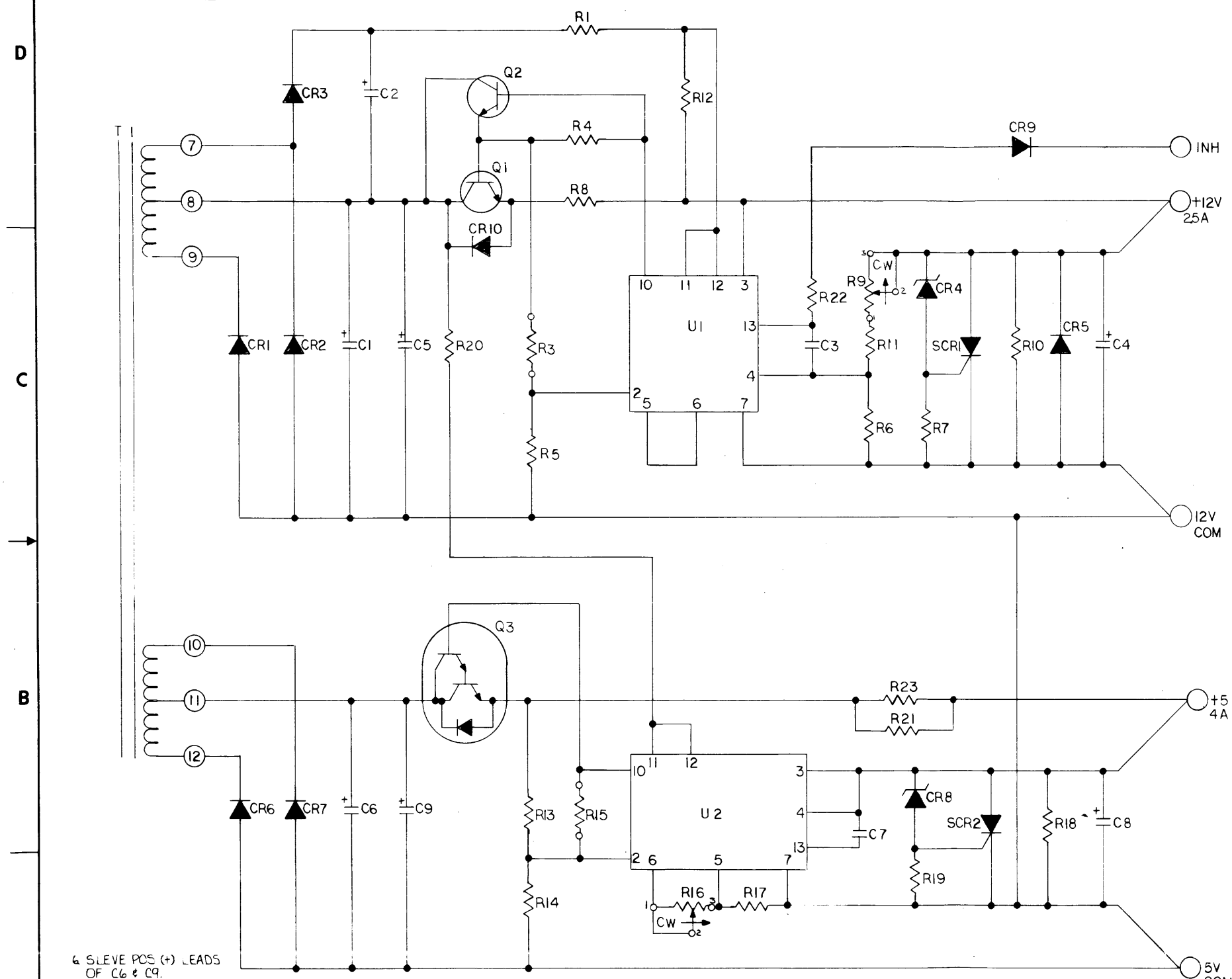

REF DES	PART OR IDENTIFYING NO.	NOMENCLATURE OR DESCRIPTION	POWER-ONE STD. P/N
C4,2	100/35 V	CAPACITOR ELECT	101-10110
C8	220/16 V		101-10107
C1,5	3300/35 V		102-10099
C6,9	9000/15 V	ELECT	102-10097
C3	.001/100 V	MYLAR	104-10093
C7	.01/100 V	CAPACITOR MYLAR	104-10095
CR1,2,6,7	MA 750	DIODE 50V	111-10256
CR3,5,9,10	IN4003	DIODE 200V	111-10251
CR4		ZENER	
CR8	IN752A	DIODE ZENER 5.6V	112-10006
SCR1		SCR	
SCR2	80303 LS3	SCR 3A 30V	160-10258
Q1	2N3771	TRANSISTOR, POWER NPN	171-10245
Q2	2N6551	TRANSISTOR, POWER NPN	172-10249
Q3	2N6055	TRANSISTOR, POWER NPN	171-10263
U1,2	μA 723	I.C. VOLTAGE REGULATOR	130-10287
R7			
R1,12	1.6 K	RESISTOR 1/2W 5% CF.	151-10370
R3	270 Ω		10351
R4,17,22	2.2 K		10373
R5	2.7 K		10375
R15	300 Ω		10352
R10,14	1 K		10365
R11	1.2 K		10367
R13	330 Ω		10353
R18,19	82 Ω		10339
R20	300 Ω		10352
R6	24K	RESISTOR 1/2W 5% CF.	151-10374
R8	.12 Ω	RESISTOR BWH 2W WW	158-10077
R21,23	.22 Ω	RESISTOR BWH 2W WW	158-10079
R9,16	2K	POTENTIOMETER ±10% .2W	154-20020
T1		TRANSFORMER	082-19259
P.C.B.		PRINTED CIRCUIT BOARD	505-19267

- SLEVE POS (+) LEADS OF C6 & C9.
- TYWRAP KNOT FOR C1,5 ON INSIDE OF BOARD TO HELP BRING C1 & C5 AWAY FROM CHASSIS.
- FACE BOTTOM PART OF CAP CRADLE TOWARD THE CENTER OF P.C.B. AND RTV CRADLE & CAP. ON C1,5,6,9.
- THIS BOARD IS TESTED ON FAULTFINDER DO NOT CHANGE P.C.B. WITH CONSULTING TEST ENGINEERING.
- R4 TO BE INSTALLED BEFORE Q2.
- FACE FLAT SIDE OF HEATSINK TOWARD C5.

NOTES: UNLESS OTHERWISE SPECIFIED

QTY	STD. P/N	DESCRIPTION	USED ON	LAST REFERENCE DESIGNATION USED	APPLICATION
2	321-10479	I.C. SOCKET	U1,2		CP417
1	482-15960	HEATSINK	Q2		
4	516-10646	TY-WRAP 11V ₂	C1,5,6,9	C9 CR10 Q3 R23	
2	516-10673	HEATSINK WHT	C6,C9	SCR2 T1 U2 E	
4	0R-15570	CAP CRADLE DUAL	C1,5,6,9		
				NOT USED	
				R2	

TOLERANCE .XX = 0.20 .XXX = 0.10	CONTRACT NO.		
MATERIAL	APPROVALS	DATE	TITLE
FINISH	DRAWING: <i>Henry Minton</i> 1-7-81 CHECKED: <i>[Signature]</i> ENG. APP: <i>K.A. Chubb</i> 2-9-81 APPROVED:		SCHEMATIC
DO NOT SCALE DRAWING	SIZE	CODE IDENT NO.	DRAWING NO.
	D	54407	19269
	SCALE 2X		SHEET 1 OF 1

THIS DRAWING AND THE INFORMATION IT CONTAINS ARE THE PROPERTY OF IBM AND ARE TO BE USED ONLY FOR THE PURPOSE OF MANUFACTURING PARTS FOR IBM.

REV	DATE	IC NO.	REV	DATE	IC NO.	263-00053-100
AA		302				
BB		338				
CC		369				
						NEXT ASSEMBLY USED ON

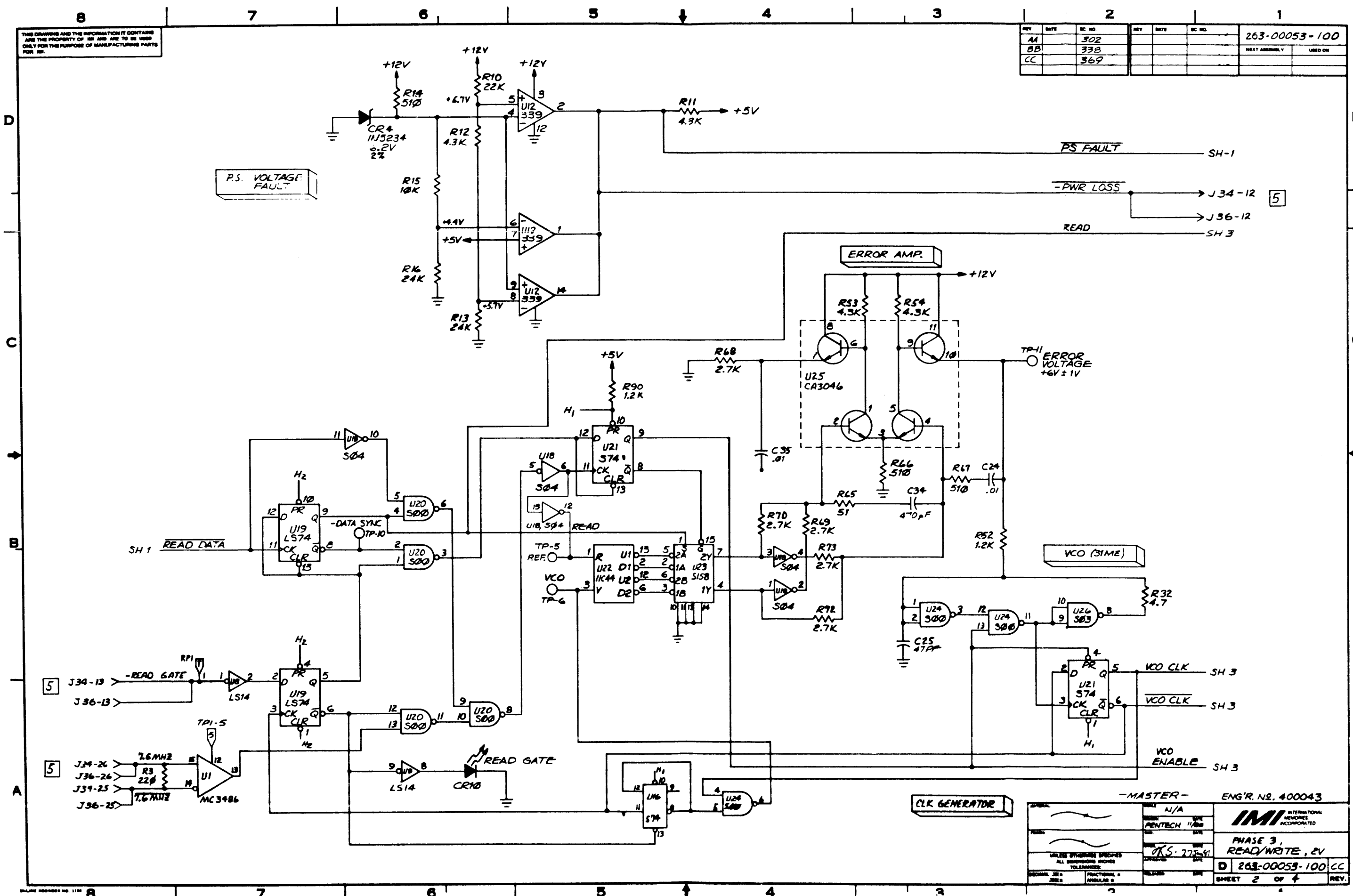

-MASTER-		ENG'R. NO. 400043
DATE	N/A	 INTERNATIONAL BUSINESS MACHINES CORPORATION
DESIGNER	PENTECH	
DATE	OKS: 278-61	PHASE 3, READ/WRITE, 2V
DESIGNER		D 263-00053-100 CC
DATE		SHEET 2 OF 4
DESIGNER		REV.

THIS DRAWING AND THE INFORMATION IT CONTAINS ARE THE PROPERTY OF IBM AND ARE TO BE USED ONLY FOR THE PURPOSE OF MANUFACTURING PARTS FOR IBM.

REV	DATE	EC NO.	REV	DATE	EC NO.	263-00053-100
AA		302				
BB		378				
CC		369				

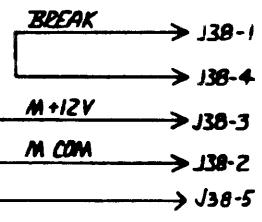
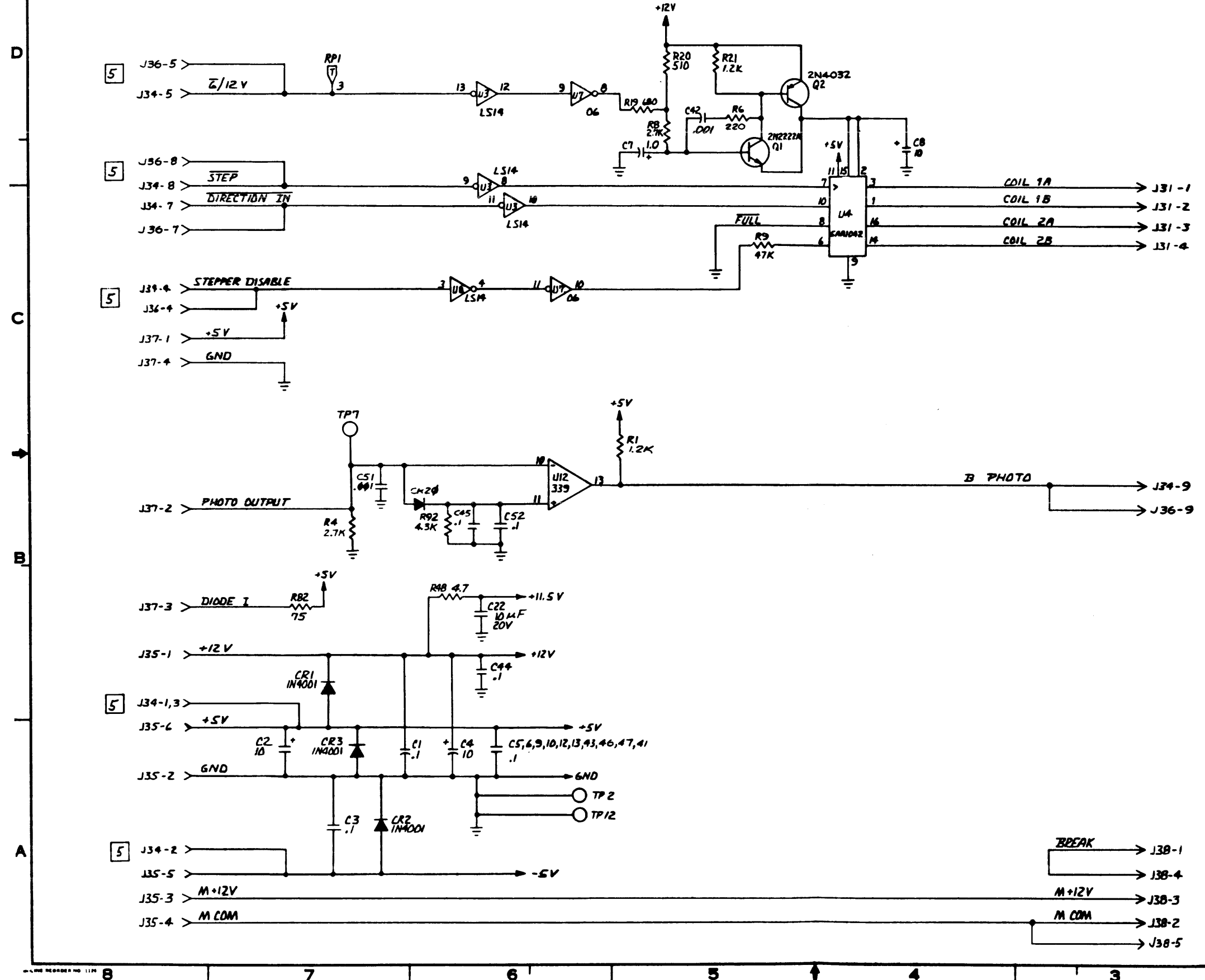

- MASTER -		ENG'R. NR. 400043
DATE	NONE	 INTERNATIONAL MEMORIAL INCORPORATED
REV	1/22/62	
UNLESS OTHERWISE SPECIFIED ALL DIMENSIONS ARE IN MILLIMETERS		PHASE 3, 2V, READ/WRITE
FORMAL SIZE & SERIAL	FRACTURE & SERIAL	D 263-00053-100 CC
		SHEET 4 OF 4 REV.

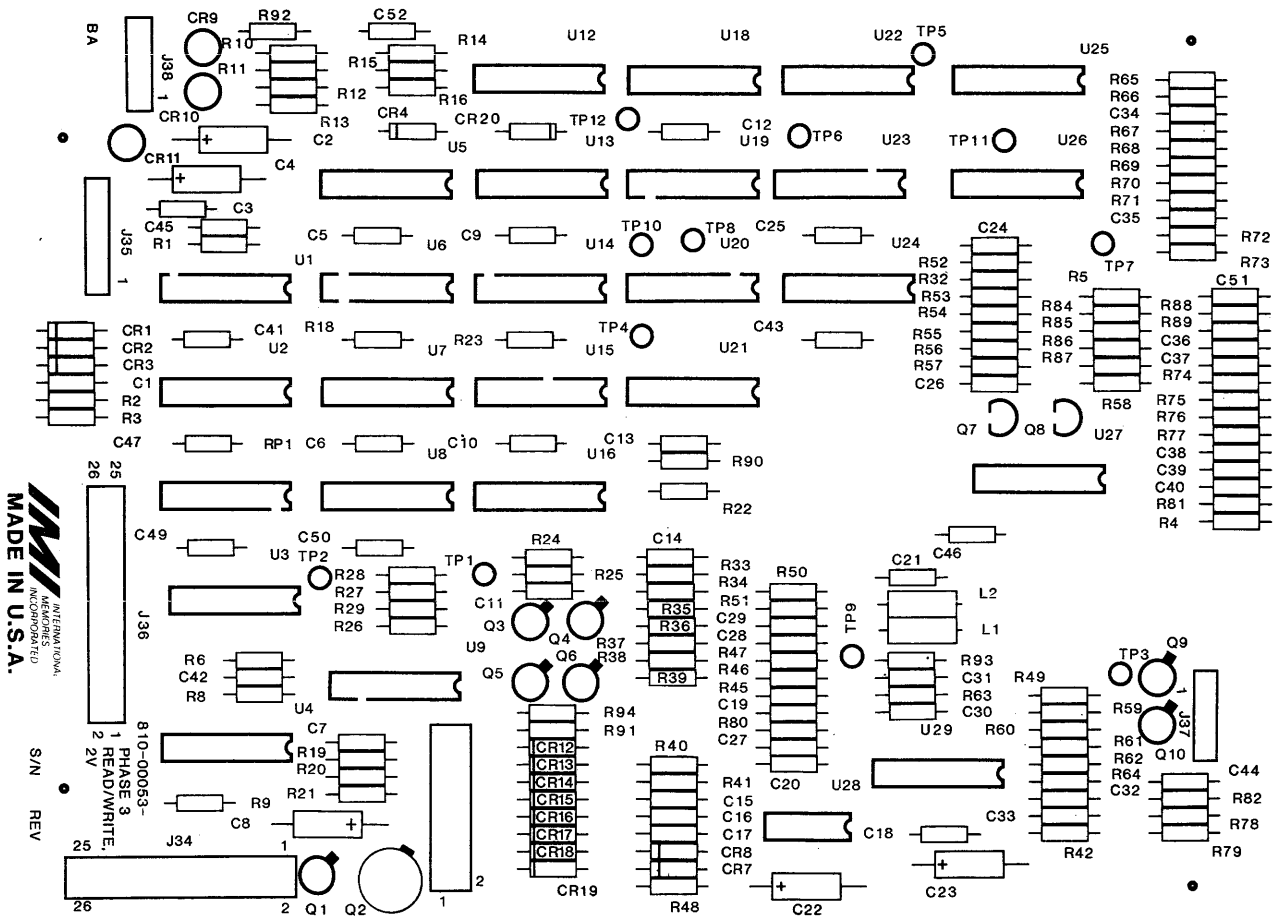

INTERNATIONAL
MEMBERS
INCORPORATED
MADE IN U.S.A.

S/N REV
810-00653-
1 PHASE 3
2 V
2 2V

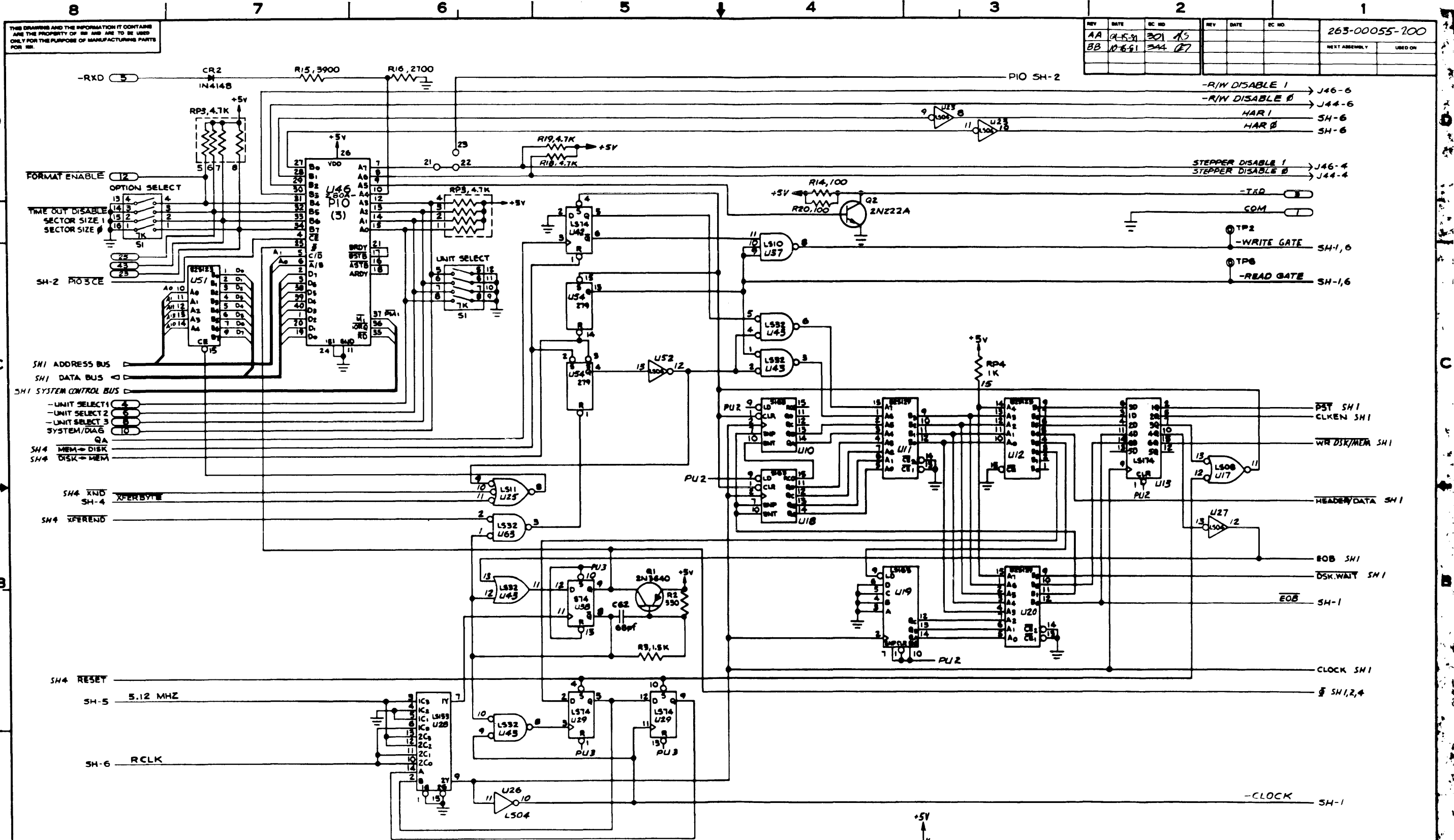

REV	DATE	EC NO	REV	DATE	EC NO	263-00055-100
AA	9-5-81	301 AS				
BB	10-6-81	344 B7				

- ORIGINAL -

ENG'R. NR. 400037

DATE	SCALE	DATE	SCALE
MIKALE 12-17-80	NONE		

IMI

5000 PHASE III CONTROLLER

D 263-00055-100 BB

SHEET 3 OF 6 REV

THIS DRAWING AND THE INFORMATION IT CONTAINS ARE THE PROPERTY OF IMI AND ARE TO BE USED ONLY FOR THE PURPOSE OF MANUFACTURING PARTS FOR IMI.

REV	DATE	EC NO	REV	DATE	EC NO	263-00055-200
AA	1-15-81	301 KS				
BB	10-16-81	324 JF				
			NEXT ASSEMBLY		USED ON	

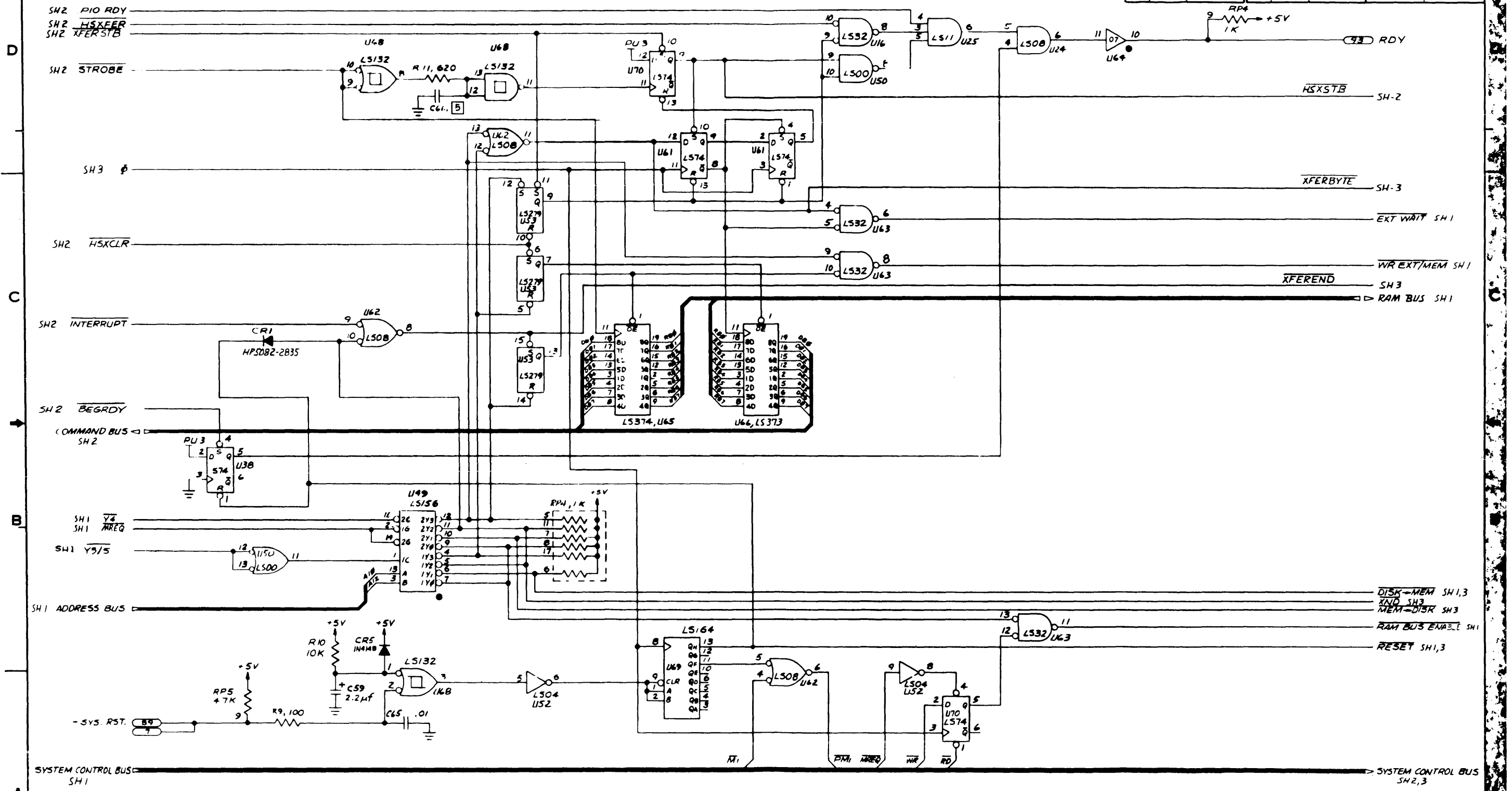

79

- ORIGINAL -

ENG'R. NO. 400037

DATE	NONE	
DATE	MIKE 1-27-81	
DATE		5000 (PHASE III)
DATE		CONTROLLER
DATE		D 263-00055-200 BB
DATE		SHEET 4 OF 6
DATE		REV

THIS DRAWING AND THE INFORMATION IT CONTAINS ARE THE PROPERTY OF IMI AND ARE TO BE USED ONLY FOR THE PURPOSE OF MANUFACTURING PARTS FOR IMI

REV	DATE	EC NO	REV	DATE	EC NO	263-00055-100
AA	9-15-81	301				
BB	10-6-81	344				
						NEXT ASSEMBLY
						USED ON

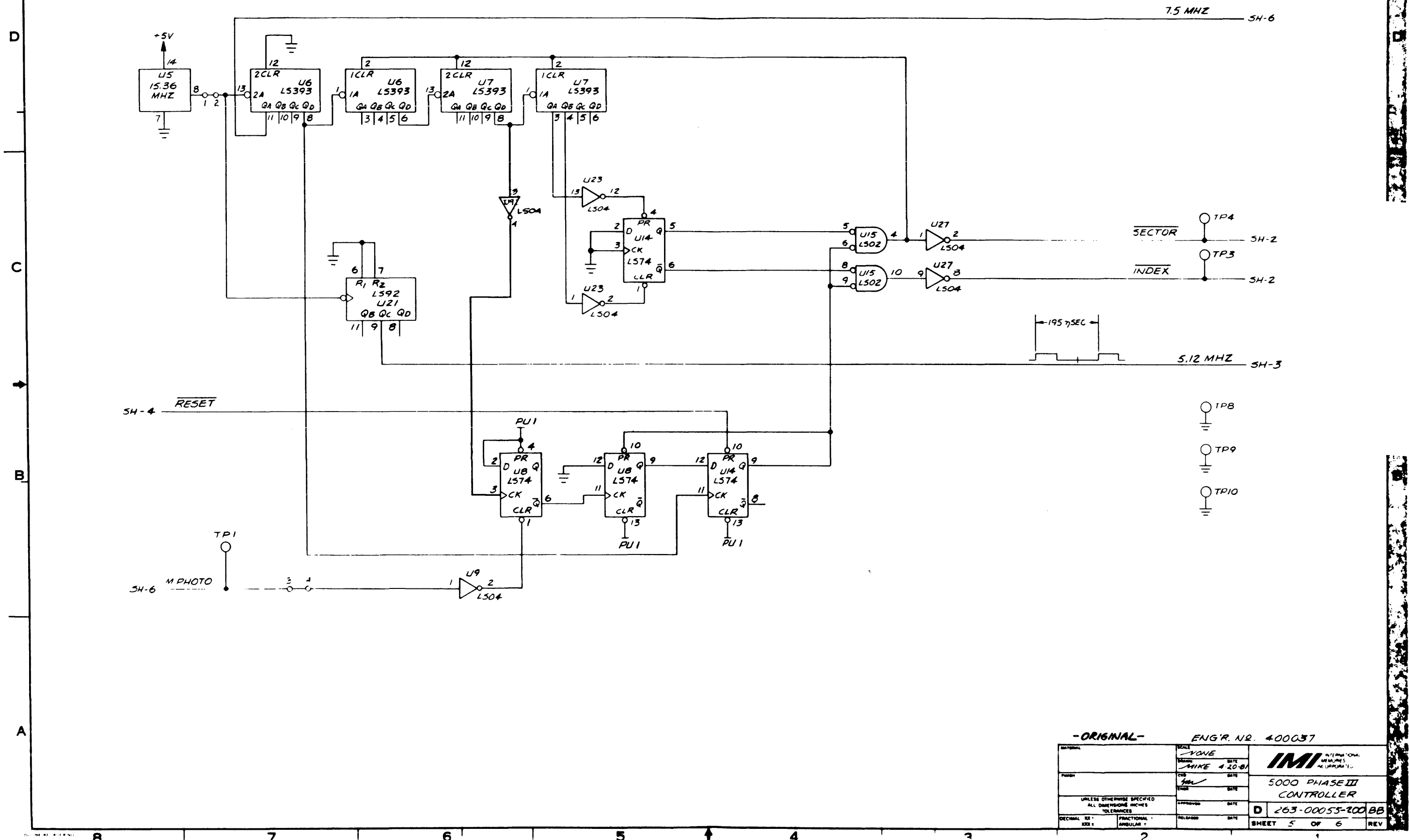

- ORIGINAL - ENG'R. NO. 400037

DESIGNED BY NONE	DATE MIKE 4-20-81	 INTERNATIONAL MEASURES AN UNLIMITED FUTURE
APPROVED BY [Signature]	DATE	
UNLESS OTHERWISE SPECIFIED ALL DIMENSIONS ARE IN INCHES TOLERANCES		5000 PHASE III CONTROLLER
DECIMAL ±	FRACTIONAL ±	D 263-00055-100 BB
RELASSED	DATE	SHEET 5 OF 6 REV

THIS DRAWING AND THE INFORMATION IT CONTAINS ARE THE PROPERTY OF IBM AND ARE TO BE USED ONLY FOR THE PURPOSE OF MANUFACTURING PARTS FOR IBM.

REV	DATE	EC NO	REV	DATE	EC NO	263-00055-200
AA	2-15-81	301				
BB	8-16-81	344				
						NEXT ASSEMBLY USED ON

D
C
B
A

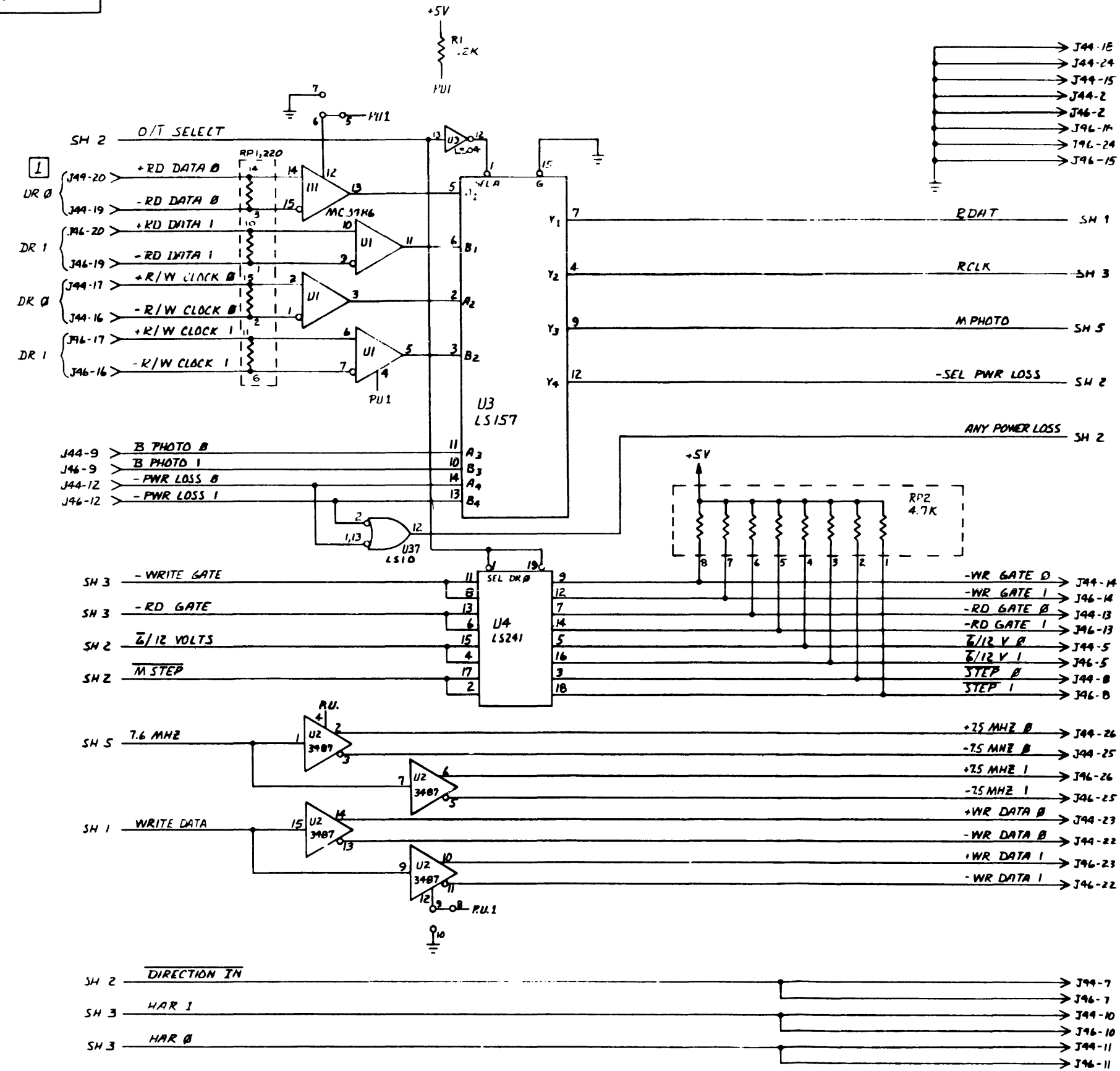

UNUSED GATES

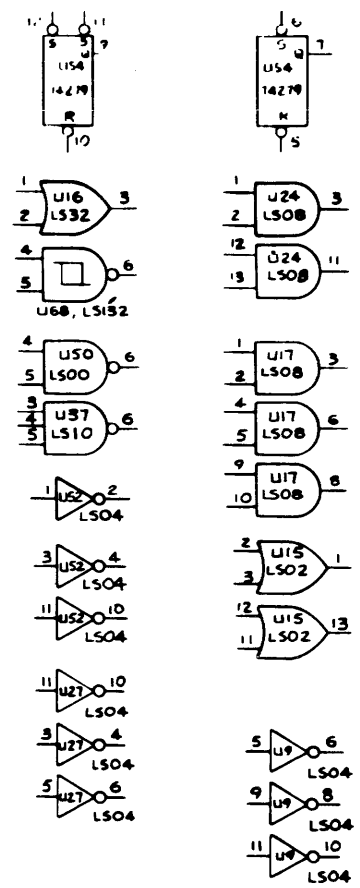

- ORIGINAL -

ENG'R. NO. 400D37

DESIGNED	DATE	BY	REVISED	DATE	BY
APPROVED	DATE	BY	APPROVED	DATE	BY
UNLESS OTHERWISE SPECIFIED ALL DIMENSIONS ARE IN INCHES TOLERANCES			FRACTIONAL 1 ANGULAR 2		
SHEET 6 OF 6			REV.		

5000 (PHASE III) CONTROLLER

D 263-00055-200 BB

CONTROLLER/LOGIC BOARD
LEGEND SILKSCREEN
310158

SH 5 OF 5
REV D

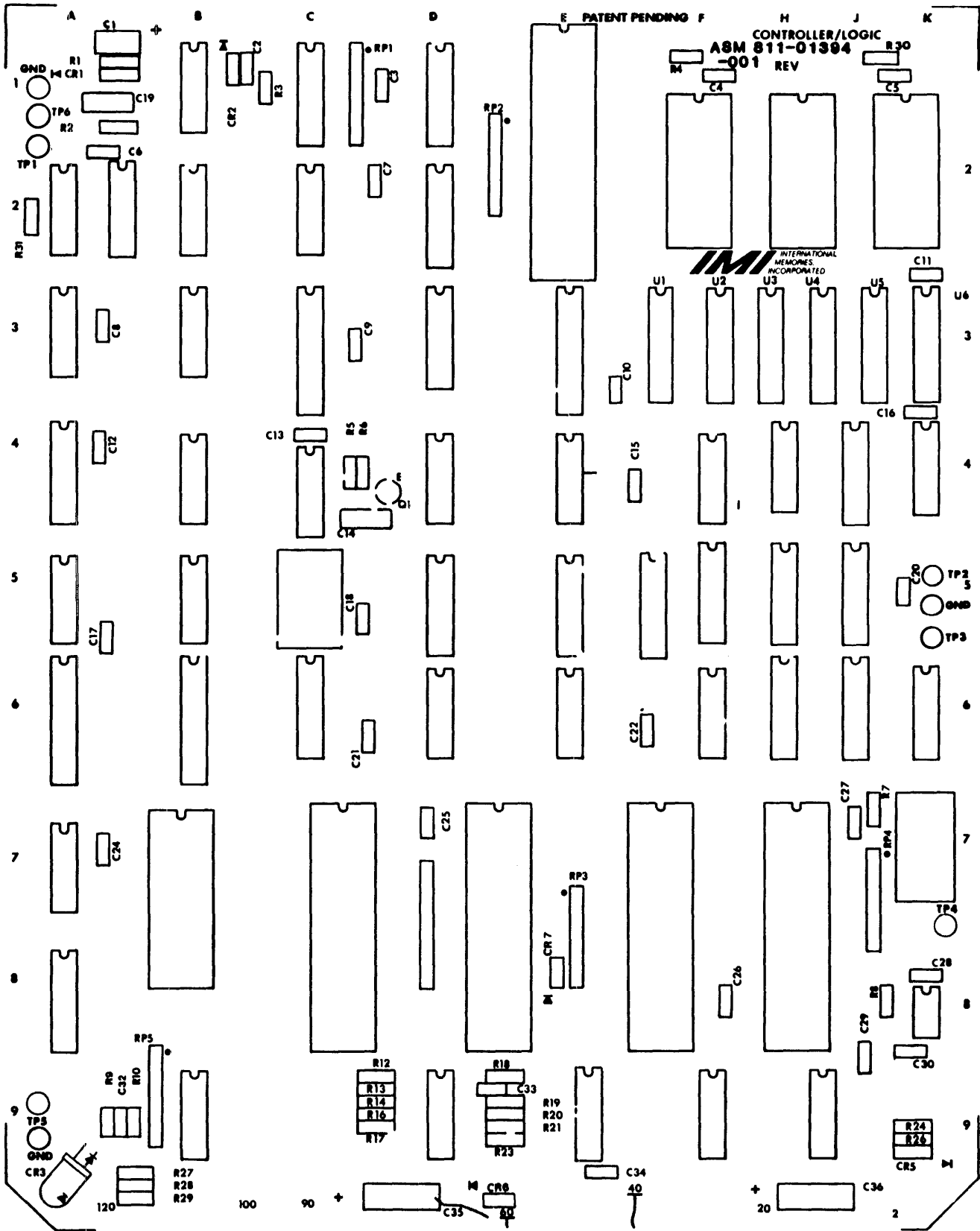

THIS DRAWING AND THE INFORMATION IT CONTAINS ARE THE PROPERTY OF IMI AND ARE TO BE USED ONLY FOR THE PURPOSE OF MANUFACTURING PARTS FOR IMI.

REV	DATE	EC NO.	REV	DATE	EC NO.
AA	01/6/61	324 JS			
BB	8/2/61	350 VP			
263-01556-00					
				NEXT ASSEMBLY	USED ON

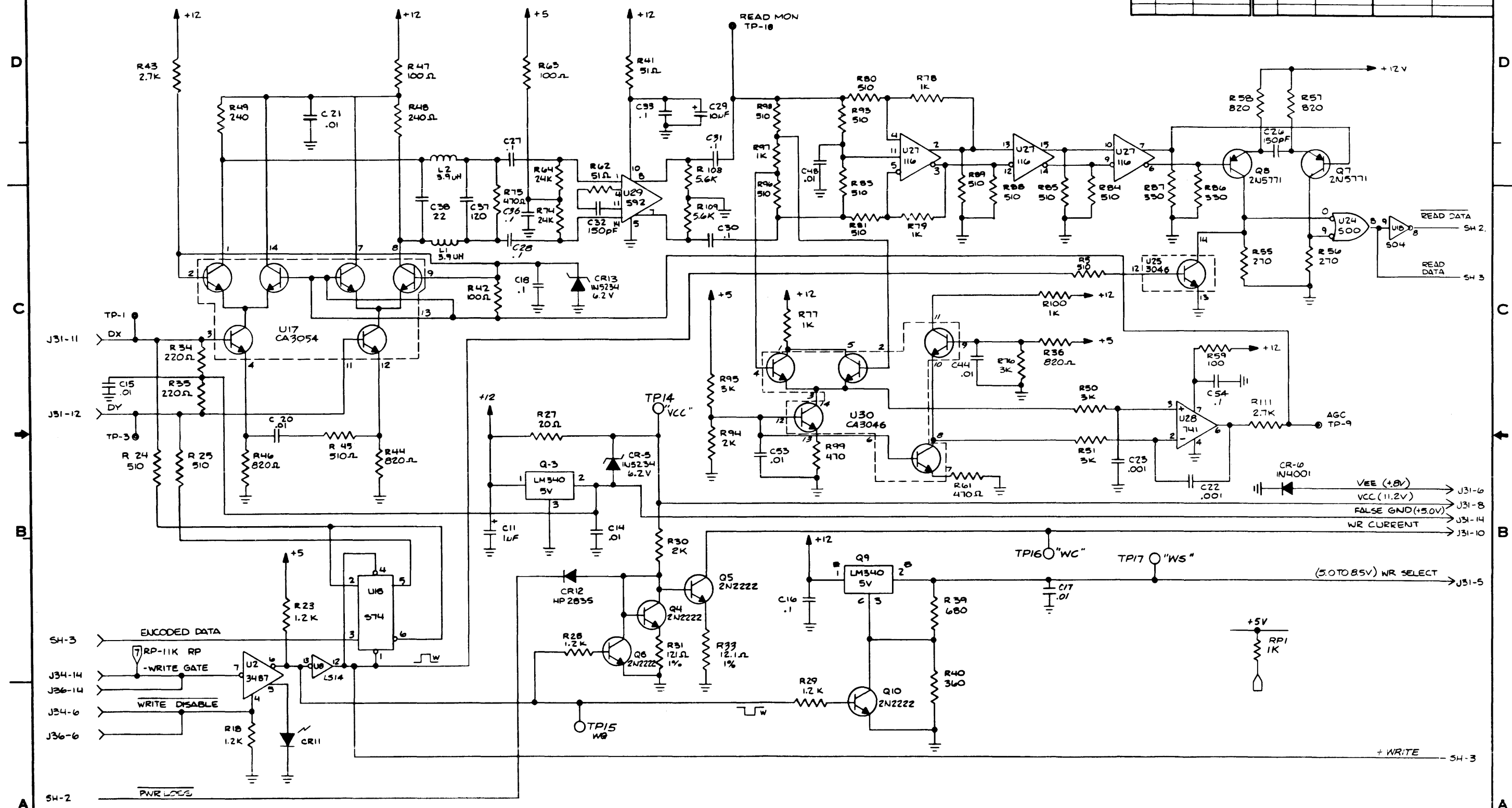

DESIGNED	SCALE	 INTERNATIONAL MEMORIES INCORPORATED
DRAWN	DATE	
CHEK	DATE	PHASE 4 R/W
APPROVED	DATE	D 263-01556-001 BB
RELEASED	DATE	SHEET 1 OF 4
DECIMAL SIZE & TOLERANCE	FRACTIONAL & TOLERANCE	REV.

THE DRAWING AND THE INFORMATION IT CONTAINS ARE THE PROPERTY OF IBM AND ARE TO BE USED ONLY FOR THE PURPOSE OF MANUFACTURING PARTS FOR IBM.

REV	DATE	BY	NO.	REV	DATE	BY	NO.
AA	10/6/81		324 MS				
BB	8/20/82		350 VB				

263-01556-001

SEE SH 1 FOR REV.

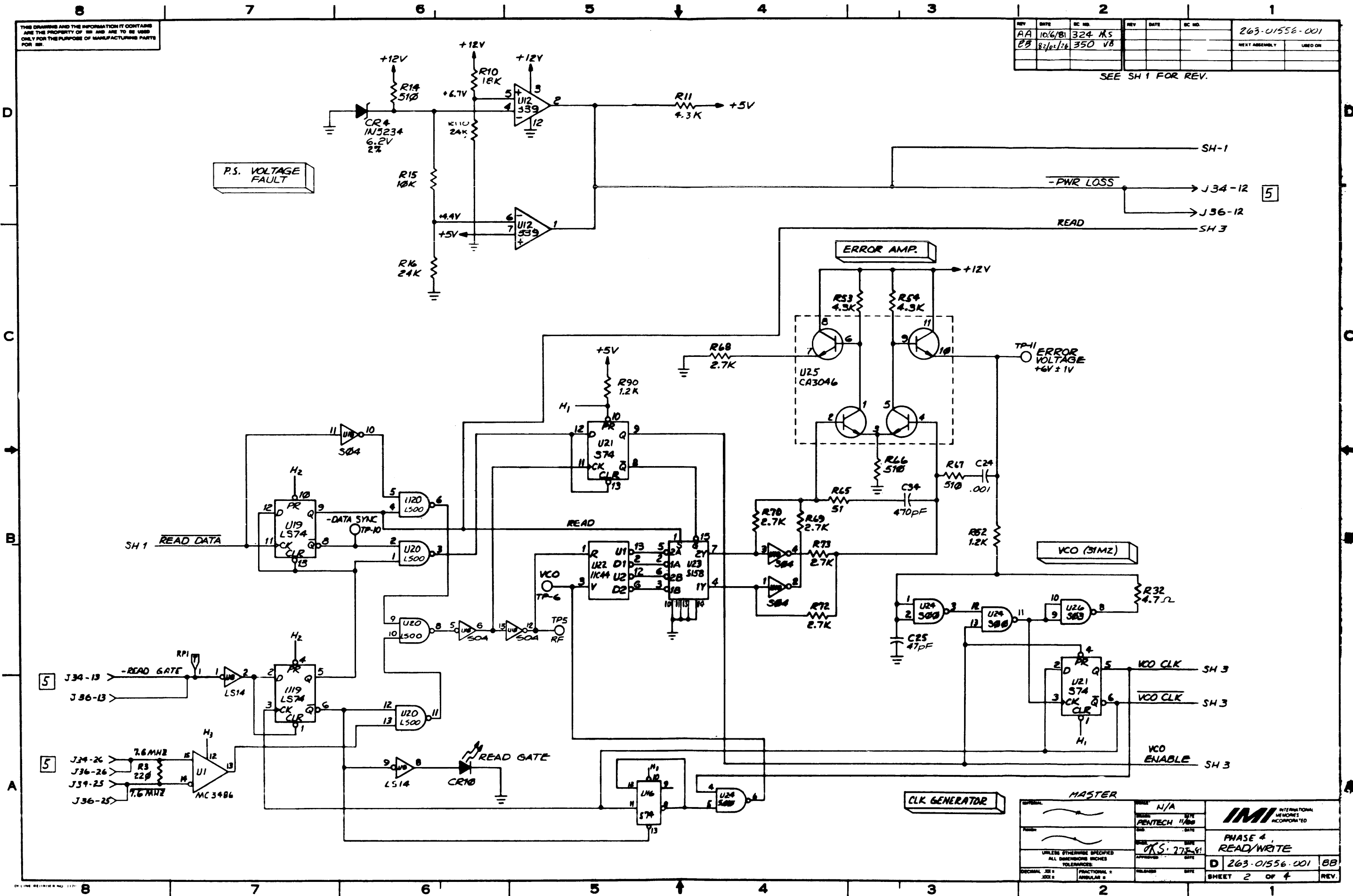

SYMBOL	DESCRIPTION	DATE	BY
~	N/A		
~	PENTECH	11/80	
~	OKS	7/7/81	

UNLESS OTHERWISE SPECIFIED ALL DIMENSIONS INCHES TOLERANCES:

DECIMAL	3/16"	FRACTIONAL	1/16"	RELEASED	DATE
---------	-------	------------	-------	----------	------

IMB INTERNATIONAL MEMORIES INCORPORATED

PHASE 4 READ/WRITE

D 263-01556-001 BB

SHEET 2 OF 4 REV.

THIS DRAWING AND THE INFORMATION IT CONTAINS ARE THE PROPERTY OF IBM AND ARE TO BE USED ONLY FOR THE PURPOSE OF MANUFACTURING PARTS FOR IBM.

REV	DATE	EC NO	REV	DATE	EC NO	263-01556-001
AA	10/6/81	324 KS				
BB	8/2/82	350 JB				
						NEXT ASSEMBLY USED ON

SEE SH1 FOR REV

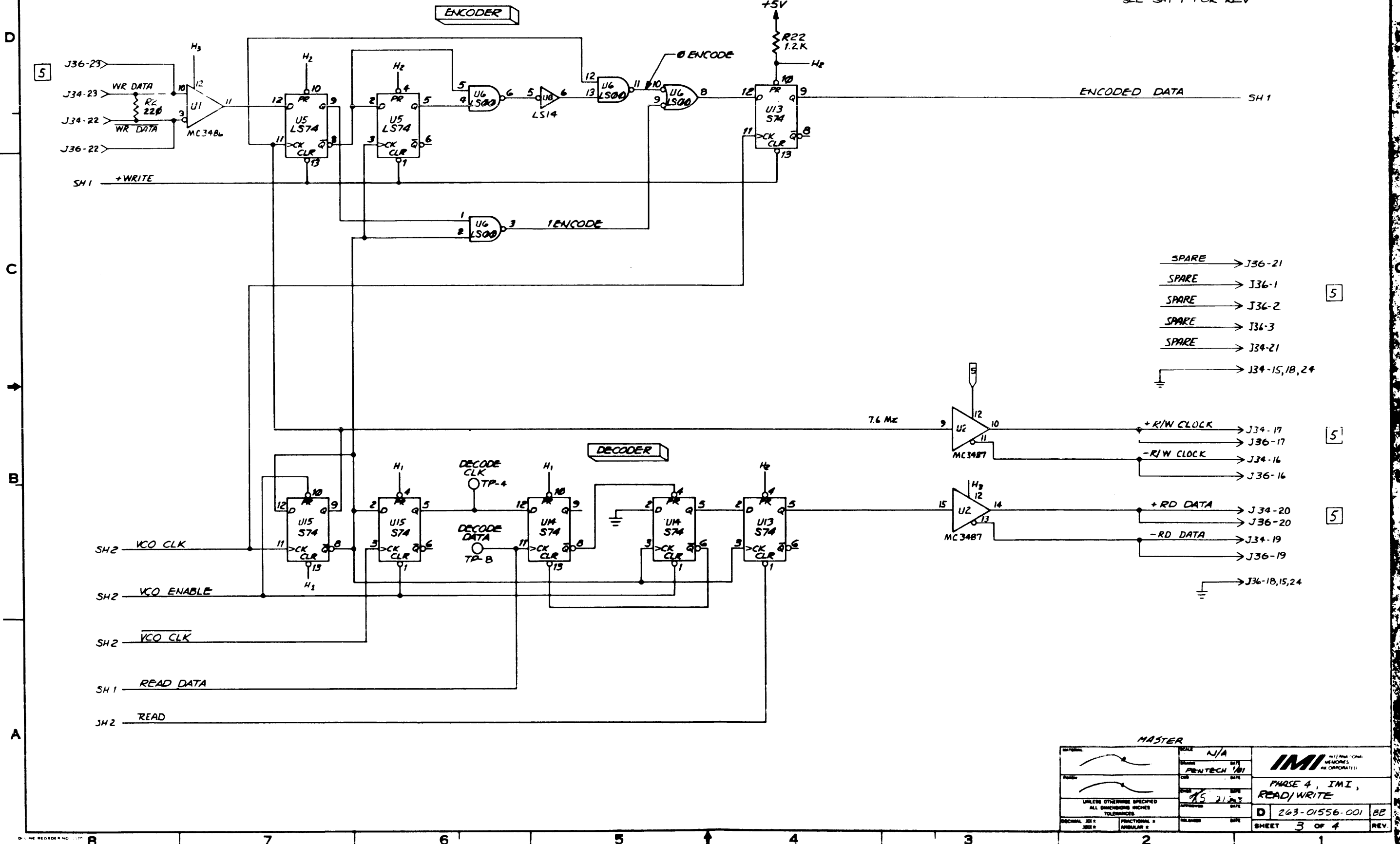

OPTIONAL		SCALE	N/A	
PENTECH 181		DATE		
UNLESS OTHERWISE SPECIFIED ALL DIMENSIONS INCHES TOLERANCES:		DATE	KS 2/1/82	PHASE 4, IMI, READ/WRITE
DECIMAL 33 ±	FRACTIONAL ±	RELEASED	DATE	D 263-01556-001 BB
				SHEET 3 OF 4 REV.

THIS DRAWING AND THE INFORMATION IT CONTAINS ARE THE PROPERTY OF IMI AND ARE TO BE USED ONLY FOR THE PURPOSE OF MANUFACTURING PARTS FOR IMI.

REV	DATE	BY	CHK BY
AA			324
BB			350

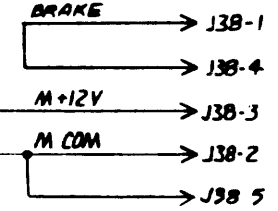
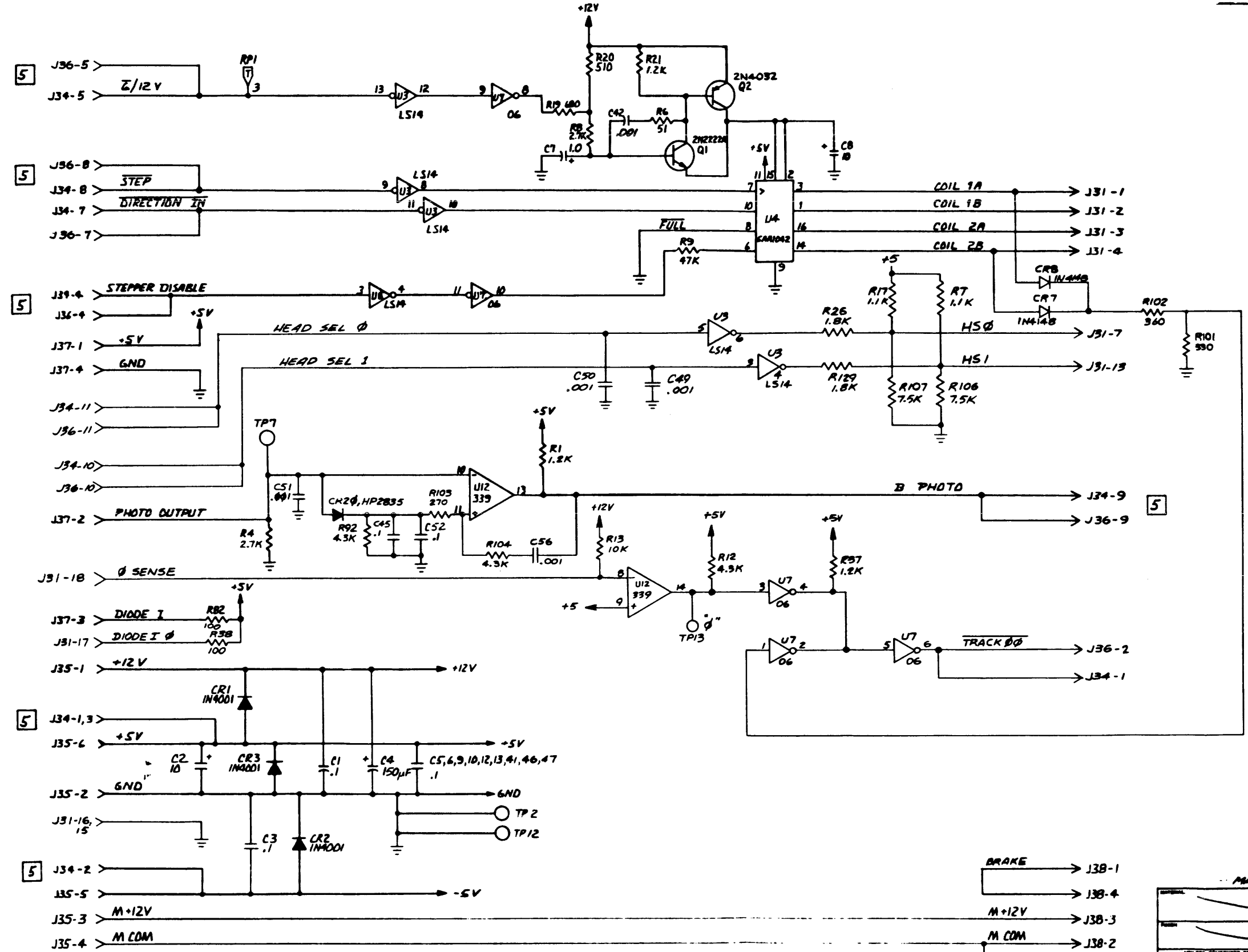

MASTER		DATE	REV
DATE	1/22/60	REV	1
UNLESS OTHERWISE SPECIFIED ALL DIMENSIONS SHOWN ARE IN INCHES		IMMI INTERNATIONAL MEMORIES INCORPORATED	
PHASE 4, READ/WRITE		D 269-01556-001 BB	
SHEET 4 OF 4		REV.	

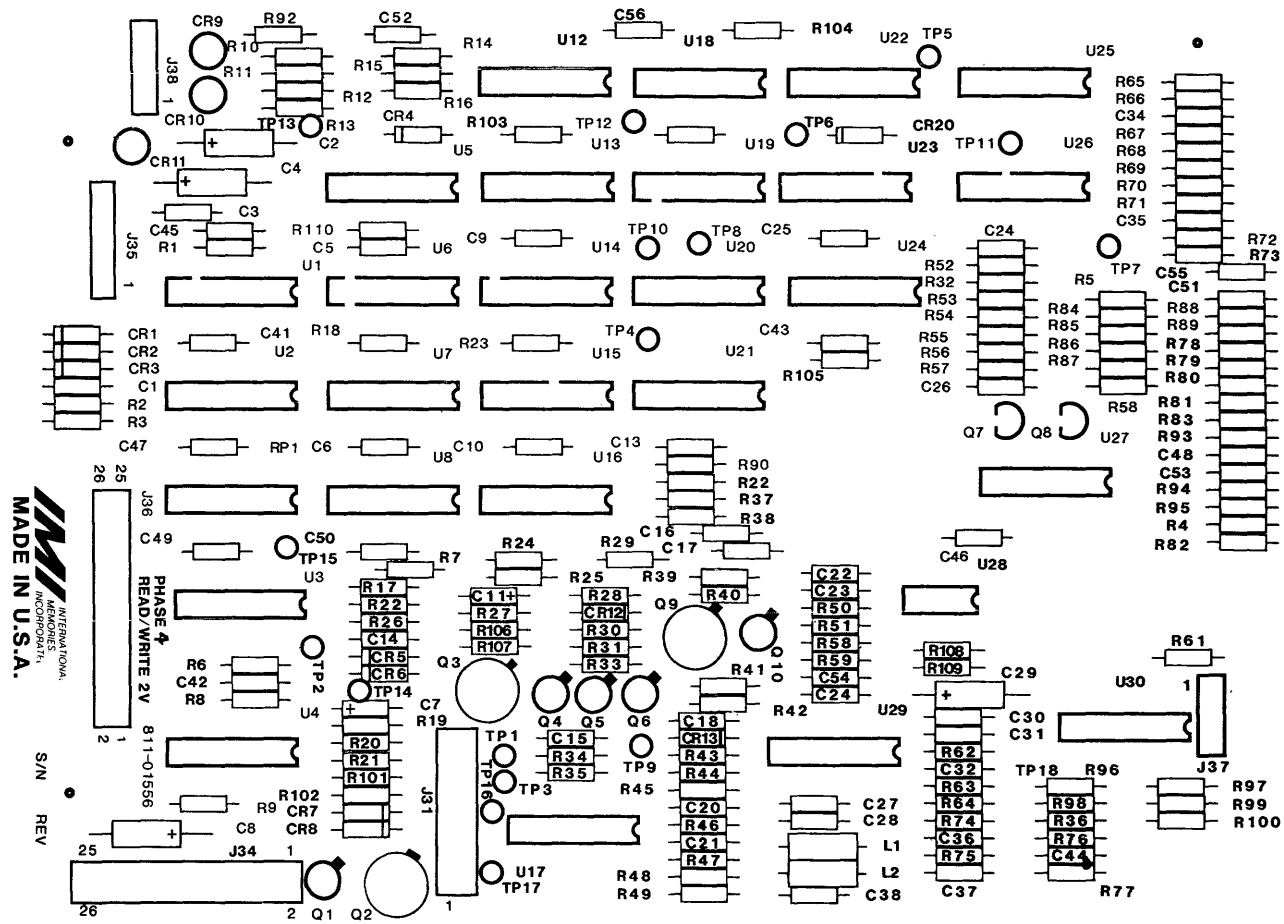

SILKSCREEN

THIS DRAWING AND THE INFORMATION IT CONTAINS ARE THE PROPERTY OF IMI AND ARE TO BE USED ONLY FOR THE PURPOSE OF MANUFACTURING PARTS FOR IMI.

REV	DATE	EC NO	REV	DATE	EC NO	263-01948-000	
AA	3-20-82	382				NEXT ASSEMBLY	USED ON

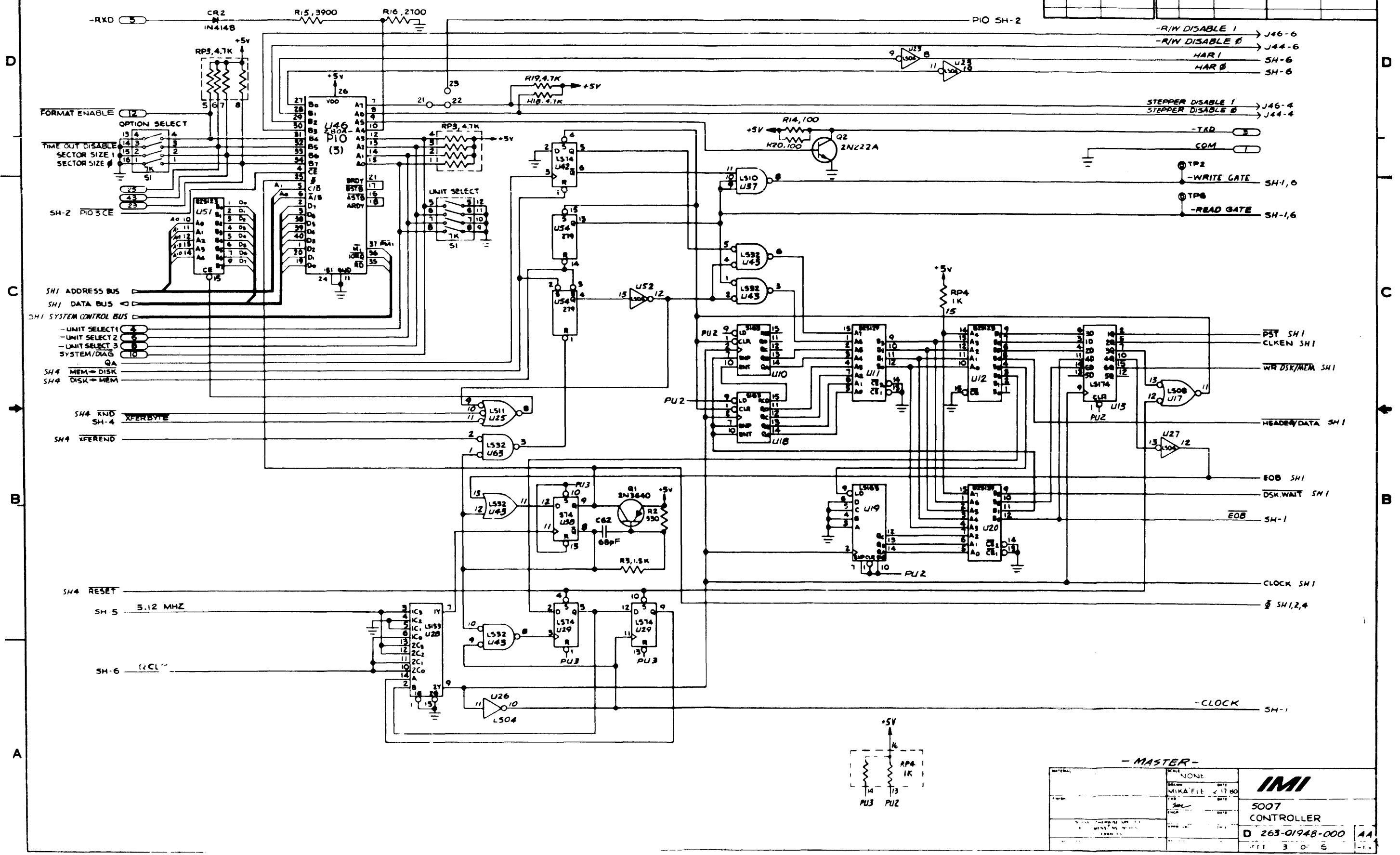

MATERIAL		SCALE		DATE		IM I	
		NONE		2-17-80		5007	
DRAWN		DATE		DATE		CONTROLLER	
CHKD		DATE		DATE		D 263-01948-000 AA	
APPROVED		DATE		DATE		REV 3 0 6	

THIS DRAWING AND THE INFORMATION IT CONTAINS ARE THE PROPERTY OF IMI AND ARE TO BE USED ONLY FOR THE PURPOSE OF MANUFACTURING PARTS FOR IMI

REV	DATE	EC NO	REV	DATE	EC NO	263-01948-000
AA	3-20-99	382				

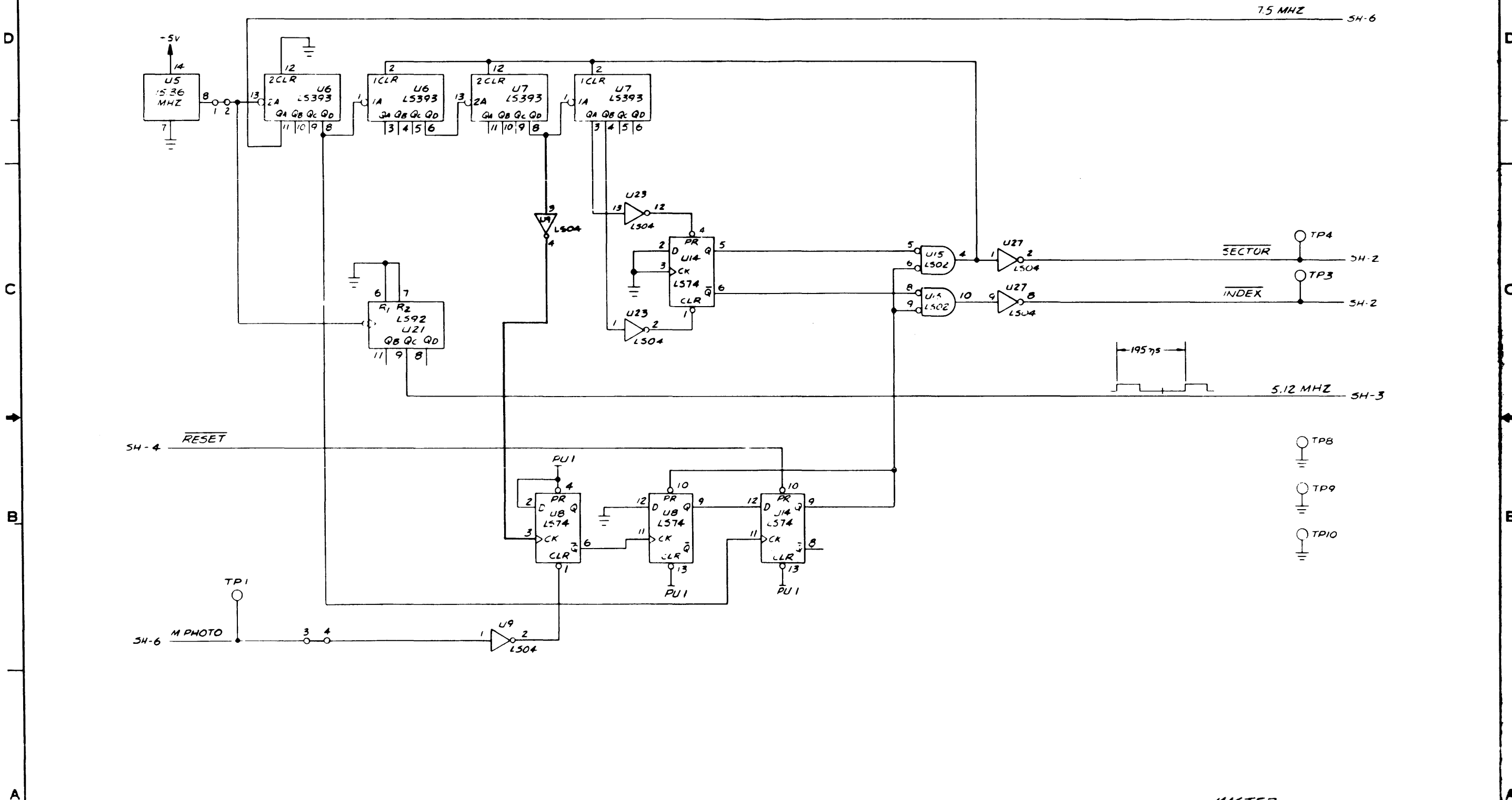

MASTER

MATERIAL	SCALE	IMI
FINISH	DRY	
UNLESS OTHERWISE SPECIFIED ALL DIMENSIONS IN INCHES TOLERANCES		5007 CONTROLLER
DECIMAL	FRACTIONAL	D 263-01948-000 AA
ANGULAR	ANGULAR	SHEET 5 OF 6

THIS DRAWING AND THE INFORMATION IT CONTAINS ARE THE PROPERTY OF IMI AND ARE TO BE USED ONLY FOR THE PURPOSE OF MANUFACTURING PARTS FOR IMI

REV	DATE	BY	CHK	APP	DATE	REV	DATE	BY	CHK	APP	DATE	263-01948-000
AA	3-20-82	382										

D
C
B
A

D
C
B
A

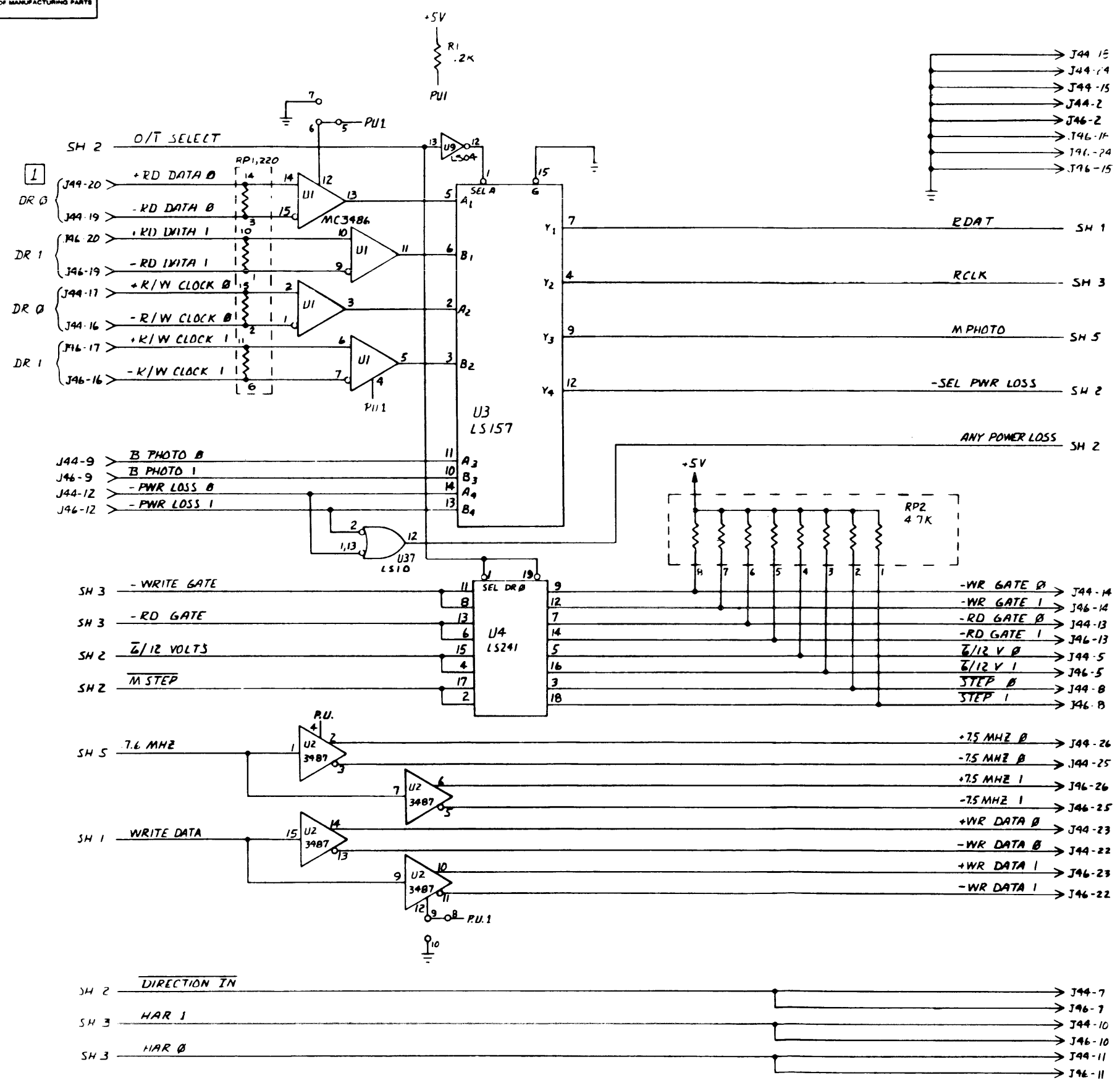

UNUSED GATES

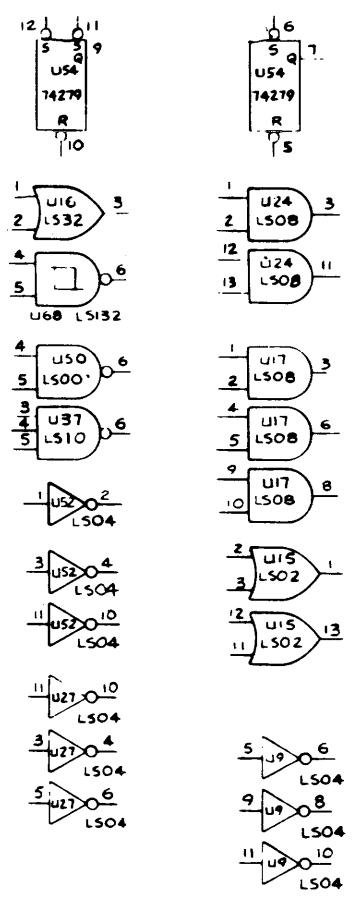

MATERIAL		SCALE	NONE		IM I	
FORM		DATE	THE CISO KID (U-2)		5007	
UNLESS OTHERWISE SPECIFIED ALL DIMENSIONS INCHES TOLERANCES		APPROVED	DATE		D 263-01948-000	
DECIMAL 22	FRACTIONAL	RELEASED	DATE		SHEET 6 OF 6	
REV	ANGULAR				REV	

ASM 811-01948-001 REV

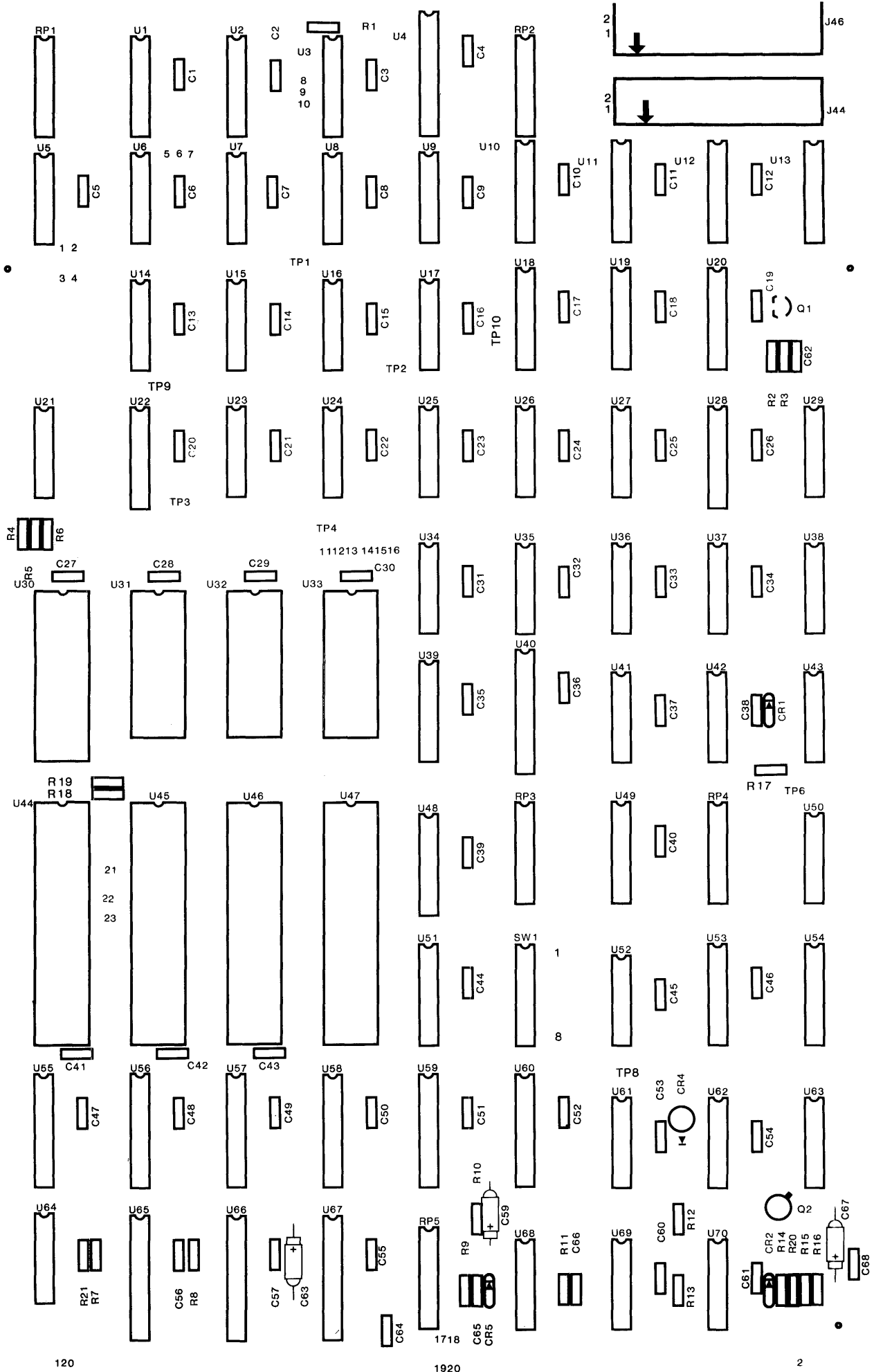

THIS DRAWING AND THE INFORMATION IT CONTAINS ARE THE PROPERTY OF IBM AND ARE TO BE USED ONLY FOR THE PURPOSE OF MANUFACTURING PARTS FOR IBM.

REV	DATE	EC NO.	REV	DATE	EC NO.	400017
X1						NEXT ASSEMBLY
X2						USED ON
X3						

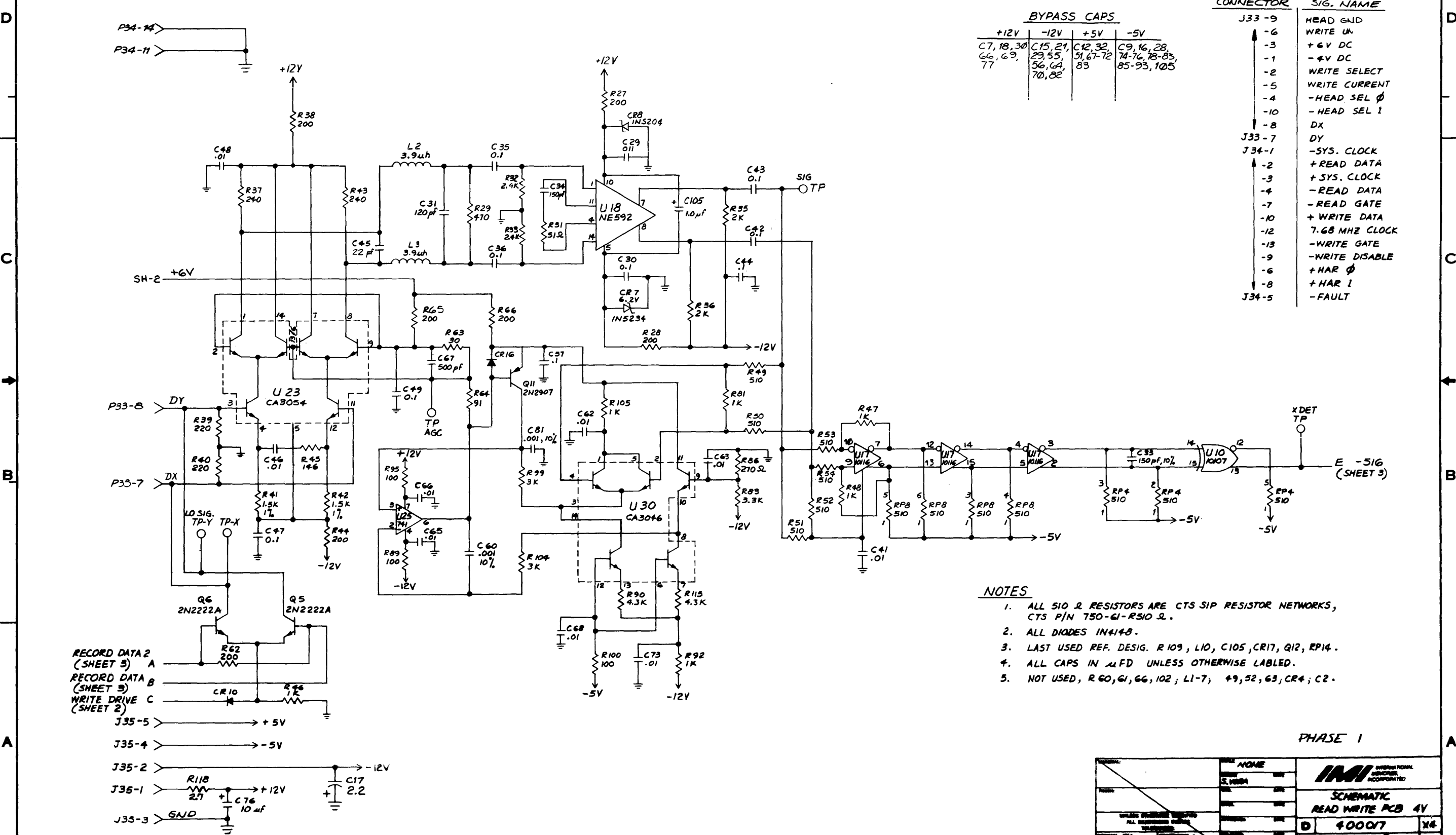

BYPASS CAPS

+12V	-12V	+5V	-5V
C7, 18, 30, 66, 69, 77	C15, 21, 29, 55, 56, 64, 70, 82	C12, 32, 51, 67-72, 83	C9, 16, 28, 74-76, 78-85, 85-93, 105

CONNECTOR SIG. NAME

J33-9	HEAD GND
-6	WRITE UN
-3	+6V DC
-1	-4V DC
-2	WRITE SELECT
-5	WRITE CURRENT
-4	-HEAD SEL 0
-10	-HEAD SEL 1
-8	DX
J33-7	DY
J34-1	-SYS. CLOCK
-2	+READ DATA
-3	+SYS. CLOCK
-4	-READ DATA
-7	-READ GATE
-10	+WRITE DATA
-12	7.68 MHZ CLOCK
-13	-WRITE GATE
-9	-WRITE DISABLE
-6	+HAR 0
-8	+HAR 1
J34-5	-FAULT

- NOTES**
1. ALL 510 Ω RESISTORS ARE CTS SIP RESISTOR NETWORKS, CTS P/N 750-61-R510 Ω.
 2. ALL DIODES IN4148.
 3. LAST USED REF. DESIG. R109, L10, C105, CR17, Q12, RP14.
 4. ALL CAPS IN μFD UNLESS OTHERWISE LABELED.
 5. NOT USED, R60, 61, 66, 102; L1-7; 49, 52, 63, CR4; C2.

PHASE 1

APPROVED	DATE	BY	APPROVED	DATE	BY
SCHEMATIC READ WRITE PCB 4V					
D 400017			X4		
SHEET 1 OF 3			REV.		

THIS DRAWING AND THE INFORMATION IT CONTAINS ARE THE PROPERTY OF IBM AND ARE TO BE USED ONLY FOR THE PURPOSE OF MANUFACTURING PARTS FOR IBM.

REV	DATE	EC NO.	REV	DATE	EC NO.
X1					
X2					
X3					
X4					

400017

NEXT ASSEMBLY	USED ON
---------------	---------

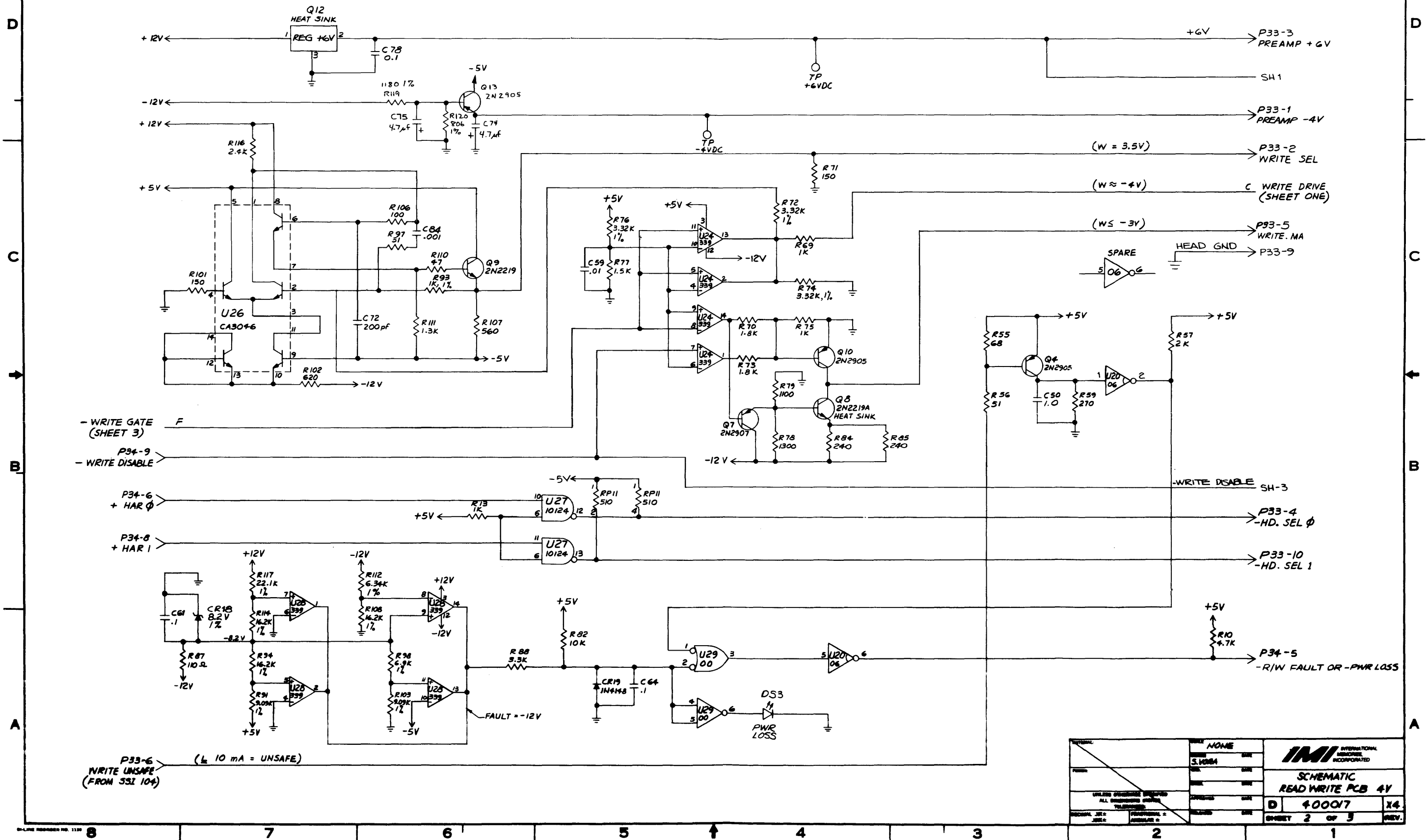

DESIGNED BY	NONE	DATE	
DRAWN BY	S.1084	DATE	
CHECKED BY		DATE	
APPROVED BY		DATE	
IBM INTERNATIONAL BUSINESS MACHINES CORPORATION			
SCHEMATIC			
READ WRITE PCB 4V			
REVISION	D	400017	X4
SHEET	2	OF 3	REV.

THIS DRAWING AND THE INFORMATION IT CONTAINS ARE THE PROPERTY OF IBM AND ARE TO BE USED ONLY FOR THE PURPOSE OF MANUFACTURING PARTS FOR IBM.

REV	DATE	EC NO.	REV	DATE	EC NO.	400017	
X3						NEXT ASSEMBLY	USED ON
X4							

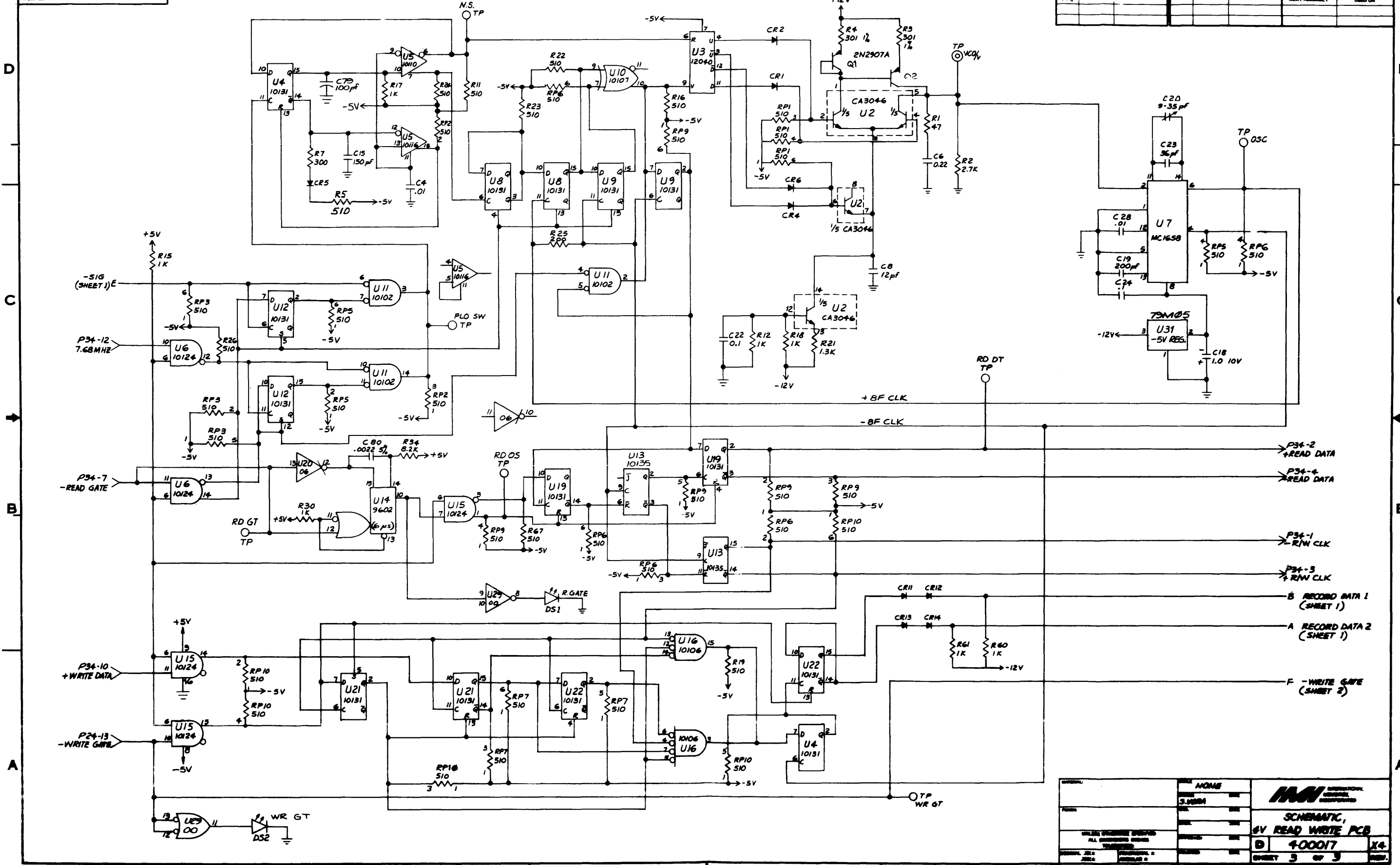

DESIGNED BY	NONE	IBM
DRAWN BY	S.M.H.	IBM
CHECKED BY		IBM
APPROVED BY		IBM
SCHEMATIC, 4V READ WRITE PCB		
REV	D	400017
SHEET	3	OF 3

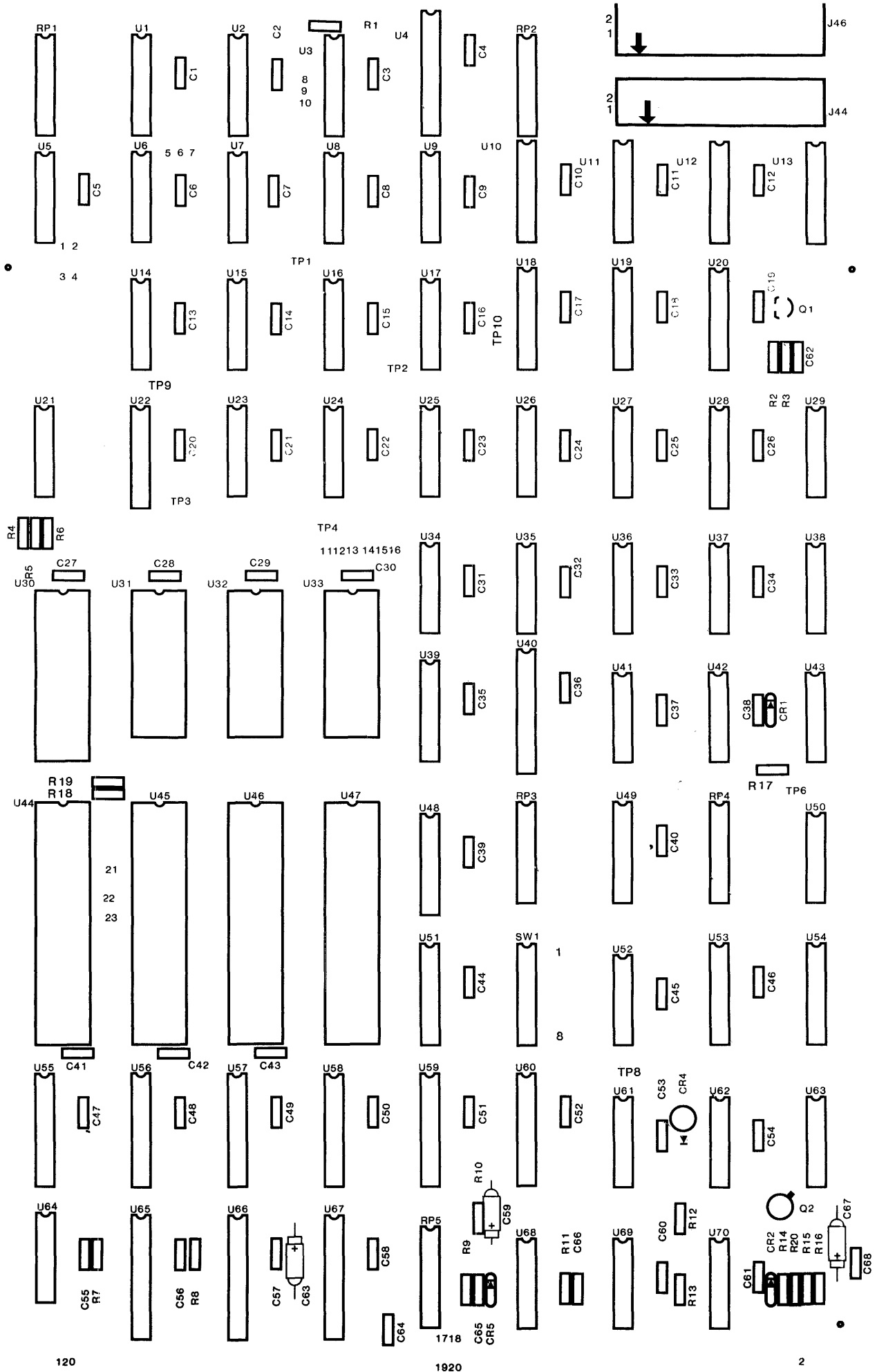

120

1920

2

THIS DRAWING AND THE INFORMATION IT CONTAINS ARE THE PROPERTY OF IMI AND ARE TO BE USED SOLELY FOR THE PURPOSE OF MANUFACTURING PARTS FOR IMI.

REV	DATE	DC NO.	REV	DATE	DC NO.
BB		270			
NEXT ASSEMBLY			USED ON		
			5007		

NOTES: UNLESS OTHERWISE SPECIFIED
 1. ALL RESISTORS ARE IN OHMS (Ω), $\frac{1}{4}$ W, 5%
 2. ALL CAPACITORS ARE MICROFARADS (μ F)
 3. ALL SN74XX SERIES I.C.'S:
 A. 14 PIN - PIN 14 = +5V, PIN 7 = GND
 B. 16 PIN - PIN 16 = +5V, PIN 8 = GND
 C. 20 PIN - PIN 20 = +5V, PIN 10 = GND

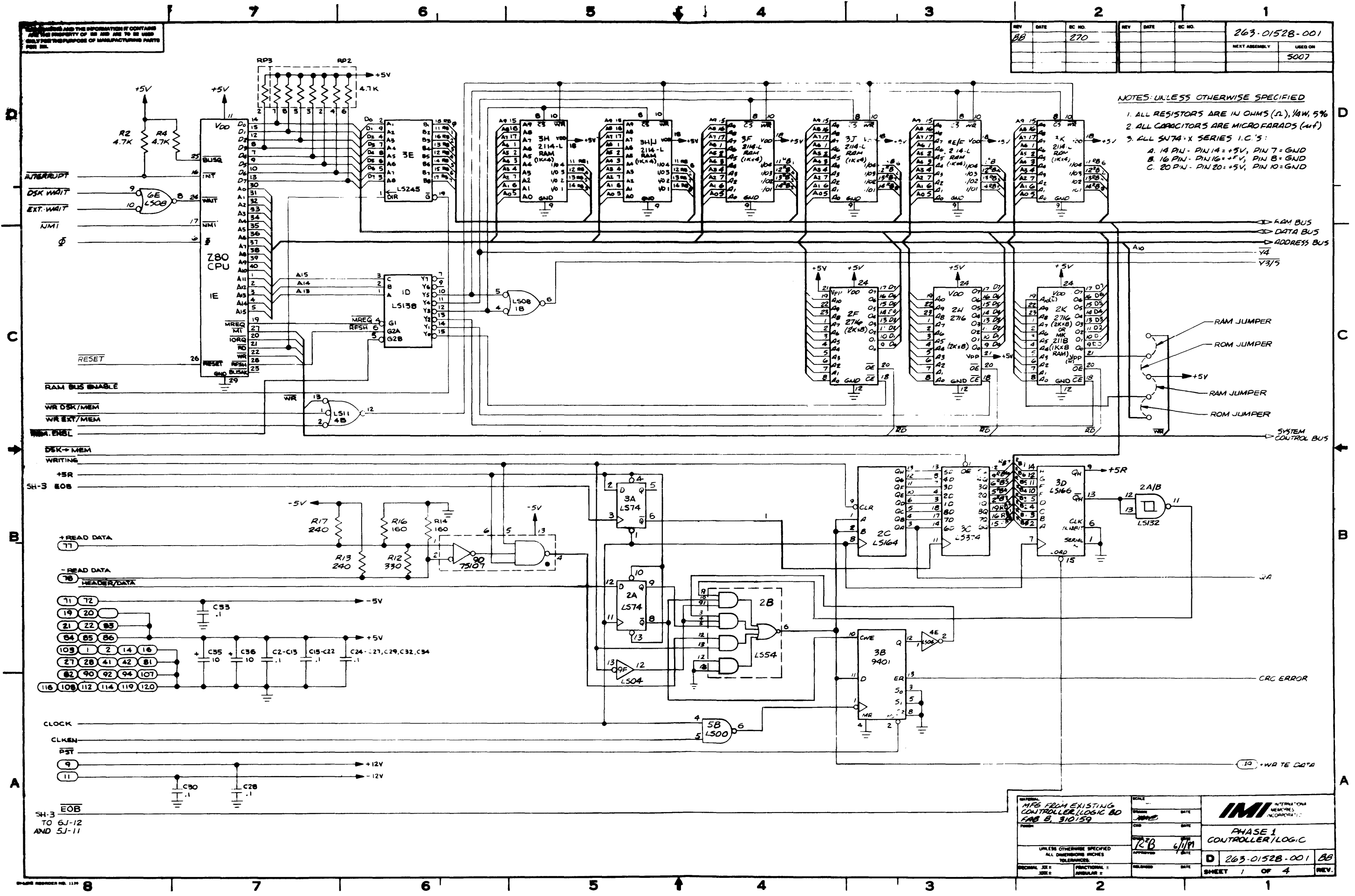

MATERIALS		SCALE		DATE	
PARTS FROM EXISTING CONTROLLER LOGIC BO FAB B, 310159		DRAWN		DATE	
UNLESS OTHERWISE SPECIFIED ALL DIMENSIONS IN INCHES		CHECKED		DATE	
TELEPHONE:		APPROVED		DATE	
MECHANICAL SIZE:		RELEASED		DATE	
JOB #:		FUNCTIONAL #:		RELEASED	
		ANNUAL #:		DATE	
				PHASE 1 CONTROLLER LOGIC	
D 263-01528-001 BB				SHEET 1 OF 4	

SH-3 EOB TO 6J-12 AND 5J-11

THIS DRAWING AND THE INFORMATION IT CONTAINS ARE THE PROPERTY OF IMI AND ARE TO BE USED ONLY FOR THE PURPOSE OF MANUFACTURING PARTS FOR IMI.

REV	DATE	EC NO.	REV	DATE	EC NO.
BB		270			
263-01528-001					
				NEXT ASSEMBLY	USEG ON
					5007

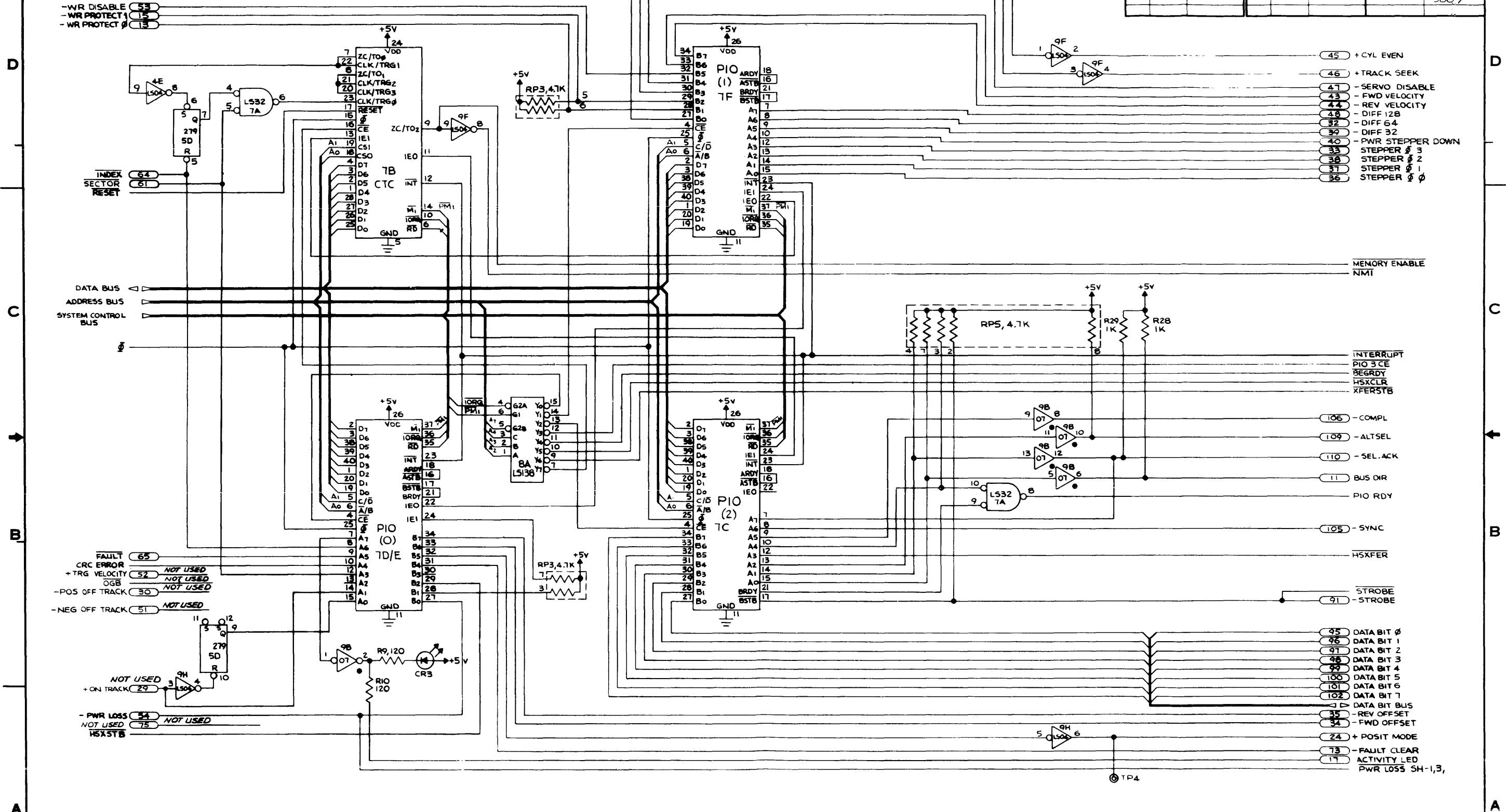

- WR DISABLE 53
- WR PROTECT 1 15
- WR PROTECT 2 15

INDEX SECTOR RESET
64
61

DATA BUS
ADDRESS BUS
SYSTEM CONTROL BUS

- FAULT 65
- CRC ERROR NOT USED
- + TRG VELOCITY 52 NOT USED
- OGB NOT USED
- POS OFF TRACK 30 NOT USED
- NEG OFF TRACK 51 NOT USED

- PWR LOSS 54 NOT USED
- NOT USED 75 NOT USED
- HSXSTB

- 45 + CYL EVEN
- 46 + TRACK SEEK
- 47 - SERVO DISABLE
- 43 - FWD VELOCITY
- 44 - REV VELOCITY
- 48 - DIFF 12B
- 49 - DIFF 64
- 39 - DIFF 32
- 40 - PWR STEPPER DOWN
- 33 STEPPER 3
- 36 STEPPER 2
- 37 STEPPER 1
- 36 STEPPER 0

MEMORY ENABLE
NMI

INTERRUPT
PIO 3 CE
BEGRDY
HSXCLR
XFERSTB

- 106 - COMPL
- 109 - ALTSEL
- 110 - SEL ACK
- 11 - BUS DR
- PIO RDY
- 105 - SYNC
- HSXFER
- STROBE
- 91 - STROBE

- 95 DATA BIT 0
- 96 DATA BIT 1
- 97 DATA BIT 2
- 98 DATA BIT 3
- 99 DATA BIT 4
- 100 DATA BIT 5
- 101 DATA BIT 6
- 102 DATA BIT 7
- DATA BIT BUS
- 35 - REV OFFSET
- 34 - FWD OFFSET
- 24 + POSIT MODE
- 73 - FAULT CLEAR
- ACTIVITY LED
- 17 PWR LOSS SH-1,3,

MATERIAL	SEE SHEET 1	SCALE	NONE	DATE	2-9-80
DESIGNER	MIKALE	DATE			
APPROVED		DATE			
UNLESS OTHERWISE SPECIFIED ALL DIMENSIONS INCHES TOLERANCES					
ORIGINAL JOB #	J002	FUNCTIONAL #		RELEASED	DATE
IMM INTERNATIONAL MEMORIES INCORPORATED				PHASE 1 CONTROLLER LOGIC	
D 263-01528-001 BB				SHEET 2 OF 4 REV.	

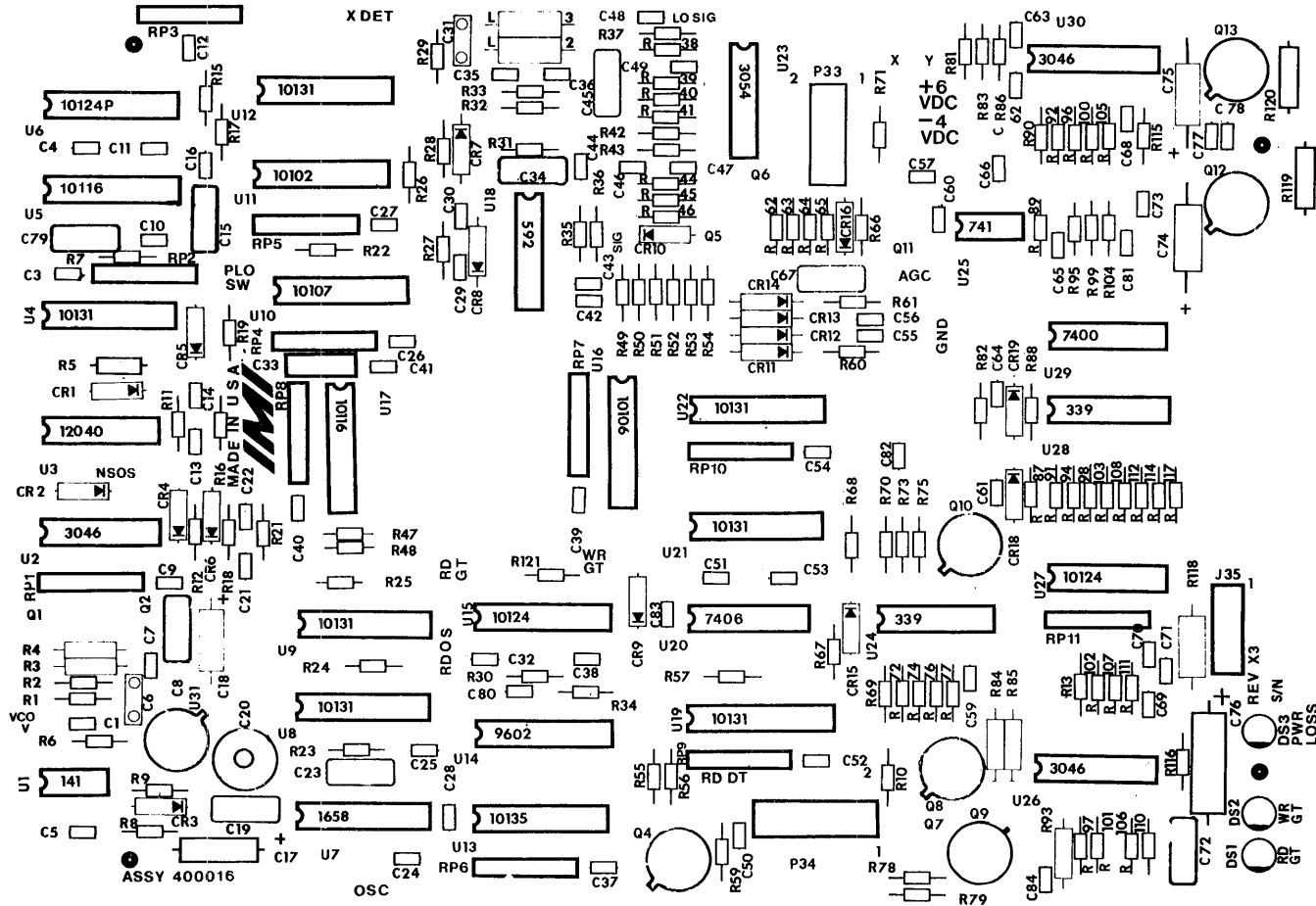

400018

REVISIONS				
PCO	REV	DESCRIPTION	DATE	APPROVED
259	A	FORMAT	20	dsilva

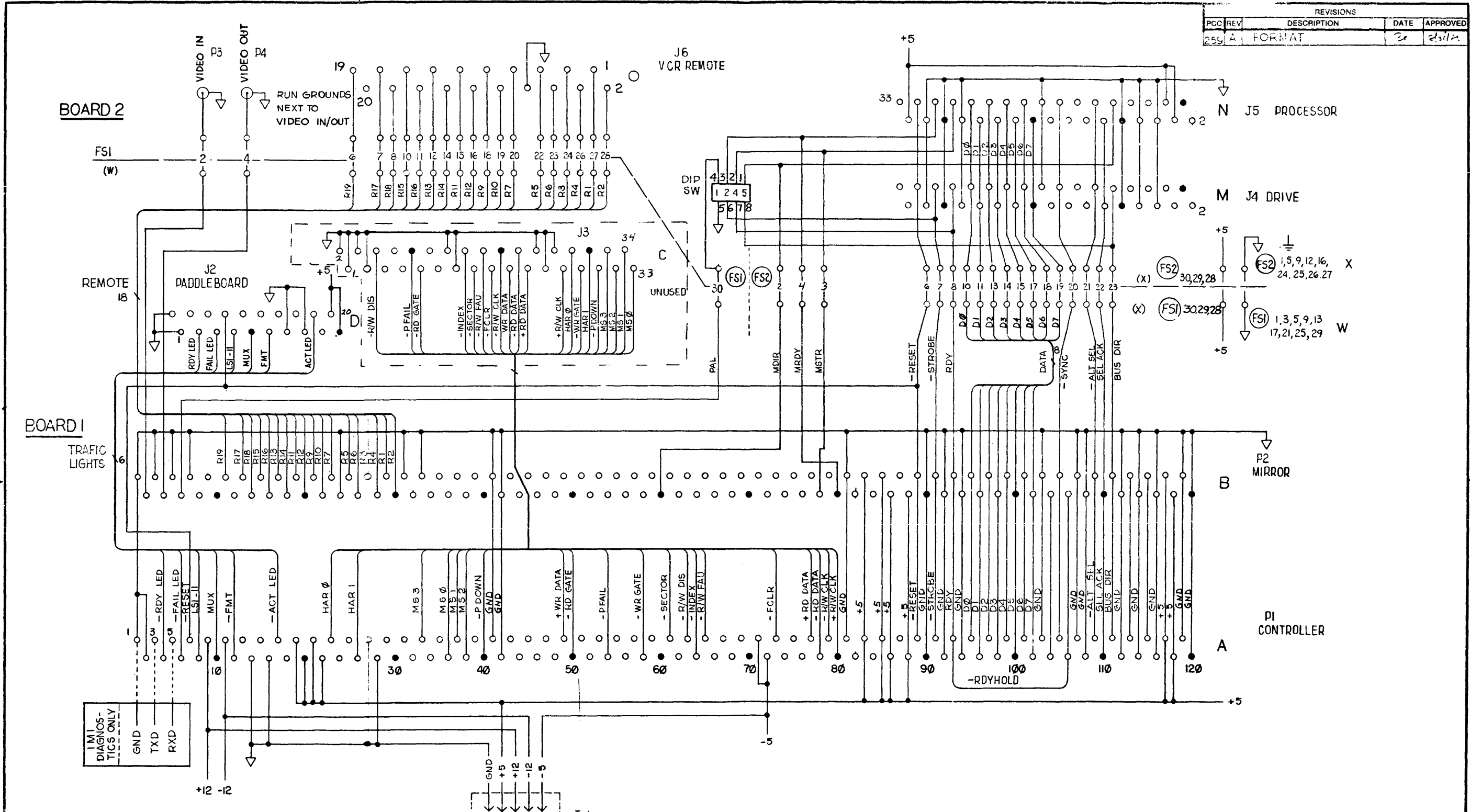

UNLESS OTHERWISE SPECIFIED DIMENSIONS ARE IN INCHES TOLERANCES ON		This document contains proprietary information and is delivered upon the expressed condition that it will not be used directly or indirectly in any way disparaging to the interest of CORVUS SYSTEMS.	★ ★ CORVUS SYSTEMS ★ 2029 O'Toole Avenue, San Jose, CA 95131	
ANGLES	DECIMALS		BACKPLANE ONE + TWO	
±	.XX ± .XXX ±	DRAWN BY HUY B.	DATE OF DRAWING 6-27-81	SCHEMATIC DWG. 1720-1791
MATERIAL		CHECKED BY	ENGINEER	
NEXT ASSY	USED ON	APPROVED		SHEET 1 OF 1
APPLICATION	FINISH	APPROVED		

REVISIONS				
PCO	REV	DESCRIPTION	DATE	APPROVED
27	A	REL. FOR MOD.		
323	B	REMOVE NOTCHES	2/26/82	JFS
380	C	DIP SW CHG-CORRECTIONS	4.14.82	JFS
669	D	CHG ITEM 2 ADD ITEM 1)	10-1-82	WIK

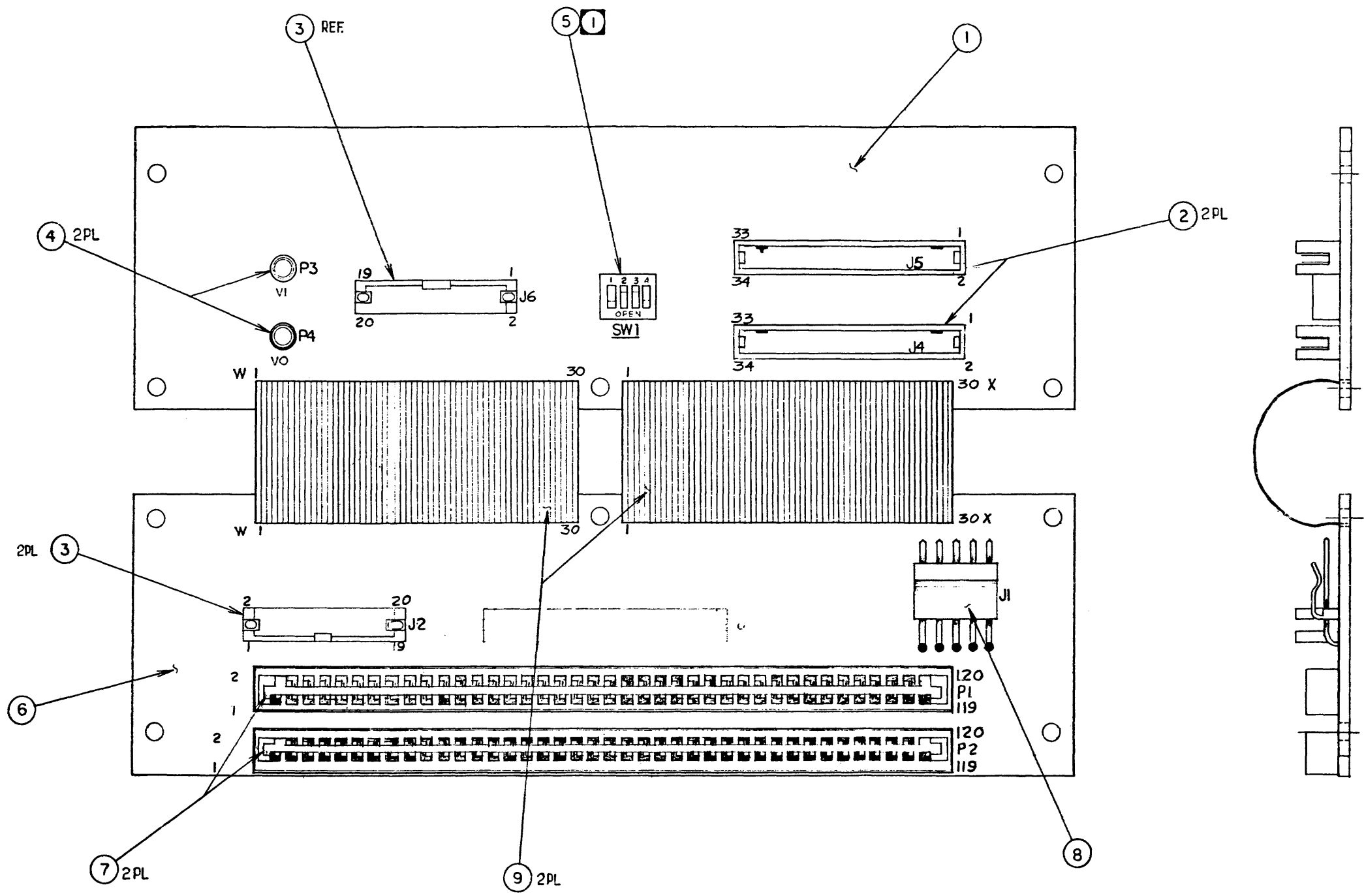

1 INSERT DIP SWITCH AS A SECONDARY OPERATION. (AFTER WAVE SOLDERING)

		UNLESS OTHERWISE SPECIFIED DIMENSIONS ARE IN INCHES TOLERANCES ON	This document contains proprietary information and is delivered upon the expressed condition that it will not be used directly or indirectly in any way detrimental to the interest of CORVUS SYSTEMS.		CORVUS SYSTEMS 2020 O'Toole Avenue, San Jose, CA 95131
		ANGLES DECIMALS ± .XX ±. .XXX ±.	DRAWN BY HUY B.	DATE OF DRAWING 12-4-81	
		MATERIAL	CHECKED BY <i>[Signature]</i>	DESIGNED BY L. FROHMAN	ASSY DWG 8010-08108
8076	TOP COVER	FINISH	APPROVED <i>[Signature]</i>	APPROVED <i>[Signature]</i>	SCALE 2:1 SHEET 1 OF 1
NEXT ASSY	USED ON	APPLICATION			