



MATADOR™



PALLADIUM 4 BURNER KITCHEN BBQ
MODEL: HS-18MAK600

Retain manual for future reference.

CONTENTS

FEATURES AND BENEFITS	3
IMPORTANT SAFETY WARNINGS	4
GAS LEAK TEST	5
GAS EMERGENCY PROCEDURE	6
GENERAL INFORMATION	7
EXPLODED PARTS VIEW	8
PARTS LIST	9
HARDWARE PACK	12
ASSEMBLY STEPS	13
BBQ LOCATION – OUTDOOR AREA	37
CONNECTION TO LPG	39
LIGHTING PROCEDURE	40
USING THE BBQ	41
USING THE SMOKER BOX	42
BBQ TIPS	43
BBQ MAINTENANCE	44
SPECIFICATIONS	51
CONNECTION TO NATURAL GAS	52
WARRANTY	54



FEATURES & BENEFITS

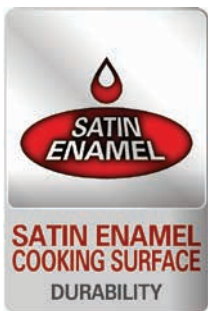
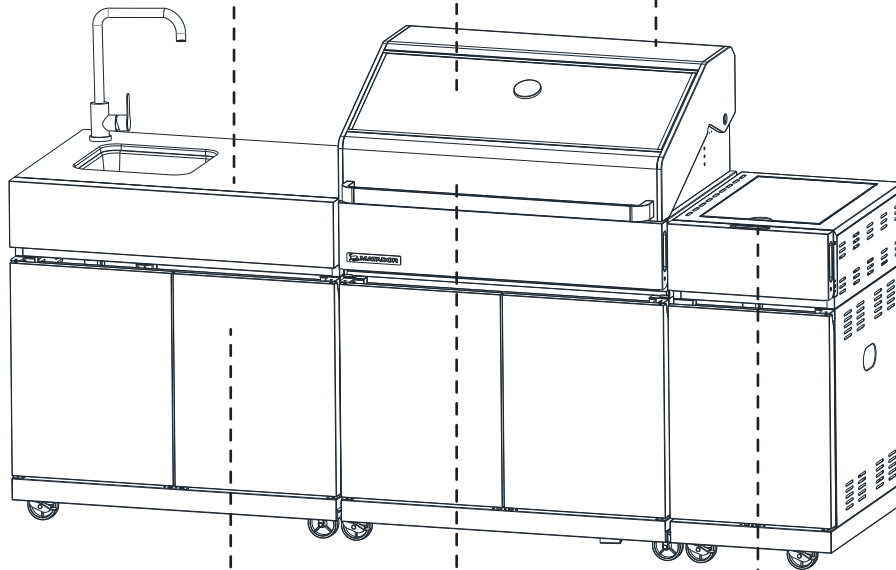

Overall Barbecue Dimensions

4B Freestanding	Length	Height	Depth
	2135 mm	1195 mm	654 mm

Gas Output

Gas Type	Burner	
	BBQ	Side
LPG / U-LPG	15 MJ/h	15 MJ/h
Natural Gas	15 MJ/h	15 MJ/h

IMPORTANT SAFETY WARNINGS

FOR OUTDOOR USE ONLY

1. DO NOT OPERATE THIS APPLIANCE BEFORE READING THE INSTRUCTION BOOKLET.
2. DO NOT PLACE ARTICLES ON OR AGAINST THIS APPLIANCE.
3. DO NOT STORE CHEMICALS OR FLAMMABLE MATERIALS OR SPRAY AEROSOLS NEAR THIS APPLIANCE.
4. DO NOT OPERATE THIS APPLIANCE INDOORS.
5. DO NOT ENCLOSE THIS APPLIANCE.
6. DO NOT LIGHT OR OPERATE WITH COVER ON.
7. Servicing can only be carried out by authorised technicians or licensed gas fitters.
8. Conduct a thorough gas leak check every time the cylinder is replaced or reconnected.
9. Do not store chemicals or flammable materials near this appliance.
10. Children must be supervised at all times while they are in the vicinity of this BBQ to prevent burn injuries and to ensure they do not attempt to use the BBQ.
11. In case of a fat fire, immediately isolate the gas supply - turn the LPG cylinder valve off.
12. Allow the BBQ to cool before removing the drip tray. Hot fat can cause serious injury.
13. This BBQ should not be located under overhead combustible construction.
14. Maintain the following minimum clearances to combustibles at all times:
From sides: 200mm **From back:** 500mm **Overhead:**1000mm
15. Turn all gas valves off including the LPG cylinder valve after use.
16. Never leave burners on high for more than 10 minutes unless actually cooking. If the burner makes a loud roaring sound when lit, it may be burning inside. If this occurs, turn the burner off, allow it to cool and light it again.
17. Do not delay ignition and allow a buildup of unburned gas.
18. Remove stickers (where fitted) from hood before use.
19. Do not store a spare LPG cylinder in the vicinity of the BBQ.



GAS LEAK TEST

Gas connections on the barbecue are leak tested at the factory prior to shipment however, a complete gas leak test must be performed during assembly. The cylinder to regulator connection must be leak tested every time the connection is made. In order to test for a gas leak, complete the following steps.

1. Make a soap solution of one part liquid detergent and one part water.

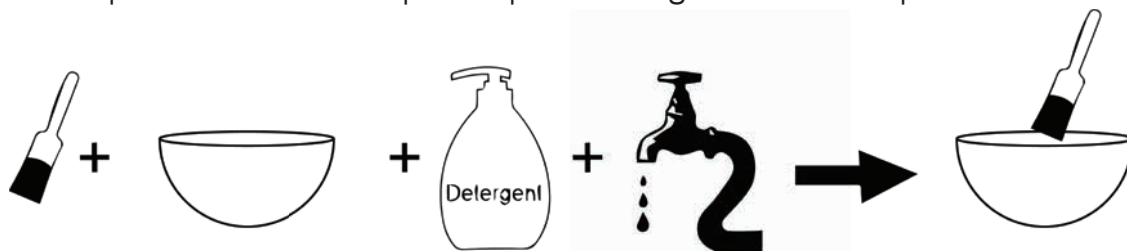

2. Ensure that the barbecue control knobs and LPG is turned off. Open the LPG cylinder valve and apply the soap solution to the gas connections using a soft bristle brush as seen below.

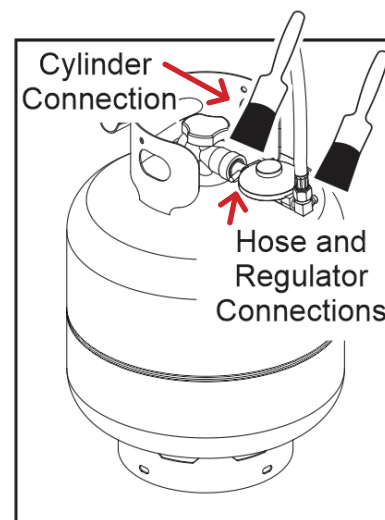
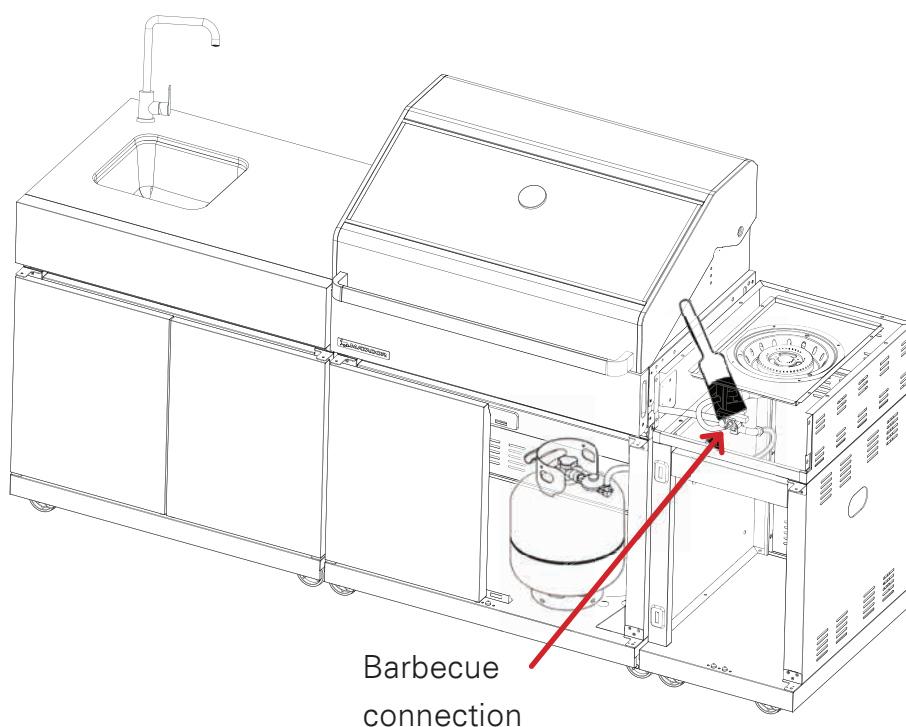

Soap bubbles will appear if there is a gas leak. In case of a leak, turn off the gas supply. Tighten any leaking fittings, then turn the gas supply on and re-check.

Warning: Do not operate the appliance until all gas leaks have been rectified. Never complete a gas leak test while smoking.

Note: If there is a leak anywhere on the gas cylinder, do not use the cylinder. Locate the leaking cylinder outdoors away from sources of ignition, then contact your local gas authority or cylinder exchange provider to arrange disposal.

GAS EMERGENCY PROCEDURE

A strong gas smell or hissing sound indicates a serious problem with your BBQ or the LPG gas cylinder. Failure to immediately follow the steps listed below could result in property damage, serious bodily injury, or even death. If a strong smell of gas or hissing sound occurs, complete the following steps.

1. Shut off the LPG cylinder valve.
2. Turn the control knobs to OFF position.
3. Put out any flame with a class B fire extinguisher and clear the area of people.
4. Move away from the LPG gas cylinder.
5. Do not try to fix the problem yourself.

If odour continues or you have a fire you cannot extinguish, call the fire department immediately.

WARNING



STORE CYLINDER IN A WELL VENTILATED AREA

STORE CYLINDER OUT OF REACH OF CHILDREN









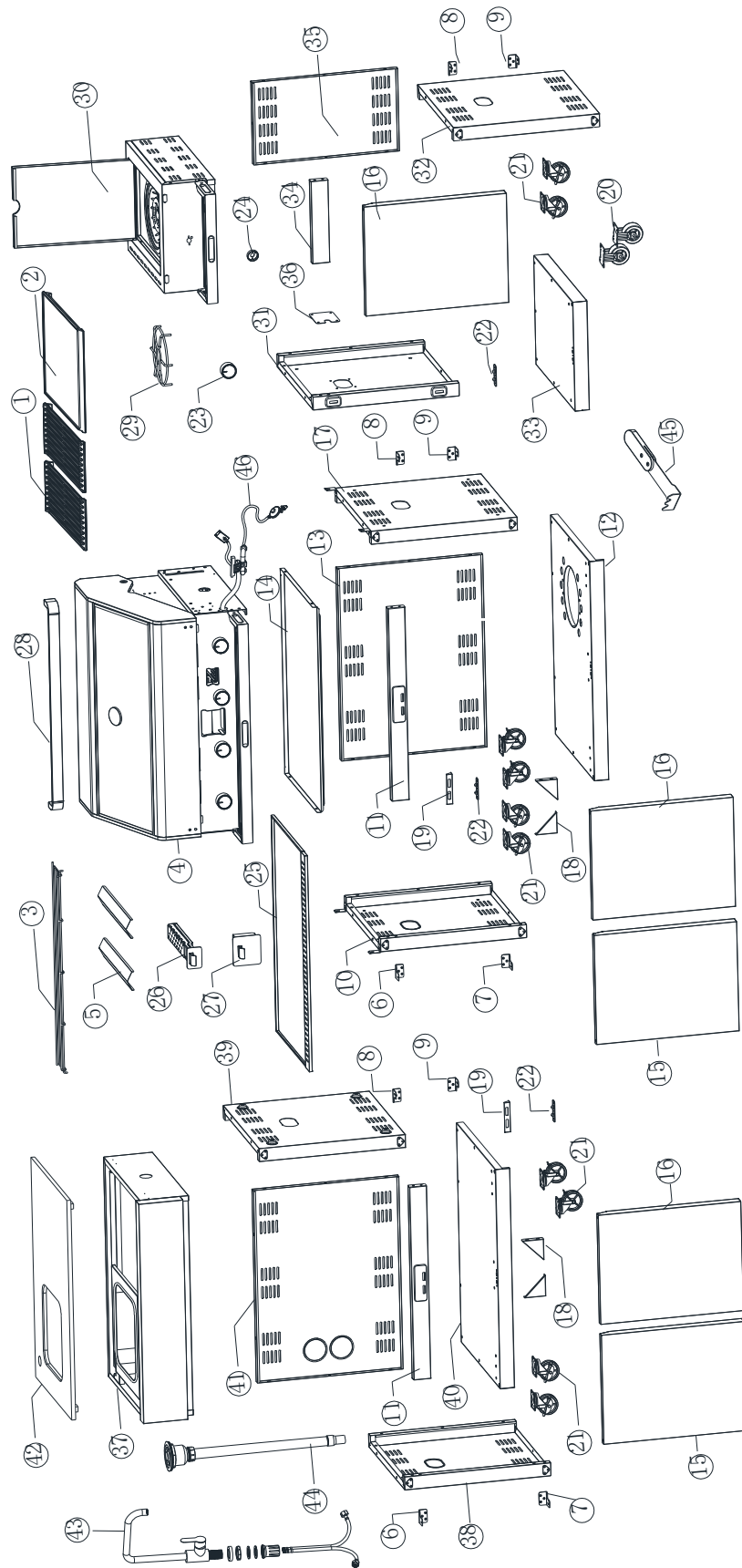

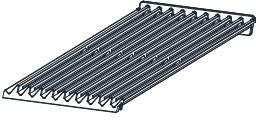

GENERAL INFORMATION

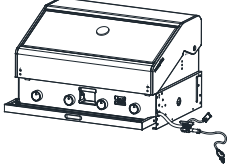
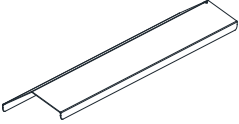
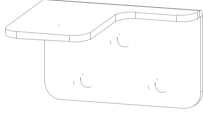
- **Note:** Before using the BBQ, remove any packaging material within and around the BBQ supplied for protection during transit.
- Improper installation, adjustment, alteration, service or maintenance can cause property damage, injury or death. Read the installation, operating and maintenance instructions thoroughly before installing or servicing this equipment.
- Strong winds and low temperatures can affect the heating and performance of your BBQ so factor in these elements when positioning your BBQ outdoors for cooking.
- Never use your BBQ in a garage, porch, shed, breezeway or any other enclosed area. Your BBQ is to be used outdoors only,. Do not obstruct the flow of ventilation air around the BBQ. This BBQ is not intended to be installed in or on recreational vehicles and/or boats.
- **Warning:** accessible parts may be very hot. Keep young children away.
- Do not move the appliance during use.
- Any modification of the appliance may be dangerous.
- Do not replace the grill with an extra hotplate. The warranty will become null and void.
- **Note:** The normal flow of gas through the Regulator and Hose Assembly can create a humming sound. A low volume of sound is perfectly normal and will not interfere with operation of the BBQ. If humming sound is loud and excessive you may need to purge air from the gas line.
- Do not store gas cylinders below ground level. LP gas is heavier than air so if a leak occurs the gas will collect at a low level and could ignite in the presence of a flame or spark.
- You must have the correct gas cylinder, regulator and hose for this BBQ to operate safely and efficiently. Use of an incorrect gas cylinder, regulator or hose is dangerous and will void the warranty on this product.

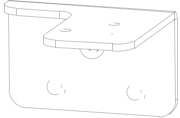
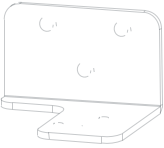
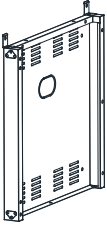

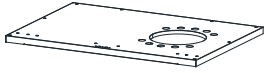
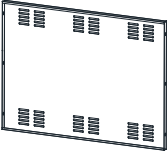





EXPLODED PARTS VIEW

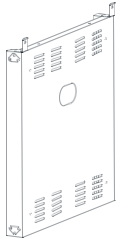
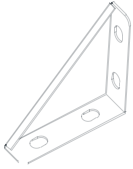
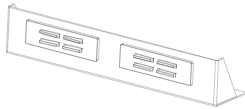
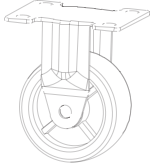
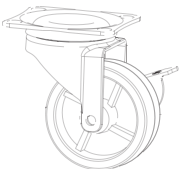

PARTS LIST

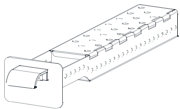
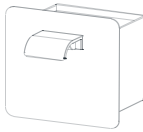

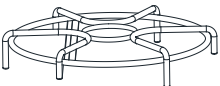
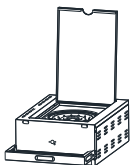









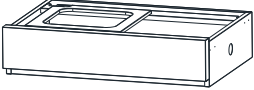

<p>1. Cooking Grill x 2</p> 	<p>2. Hotplate</p> 	<p>3. Warming rack</p> 	<p>4. Firebox</p> 
<p>5. Flame tamer x 2</p> 	<p>6. Left door hinge - upper x2</p> 	<p>7. Left door hinge - lower x2</p> 	<p>8. Right door hinge - upper x3</p> 
<p>9. Left door hinge - lower x3</p> 	<p>10. Left side cabinet panel</p> 	<p>11. Crossbeam x2</p> 	<p>12. Bottom cabinet panel</p> 
<p>13. Back cabinet panel</p> 	<p>14. Separation cabinet panel</p> 	<p>15. Left door x2</p> 	<p>16. Right door x3</p> 

PARTS LIST

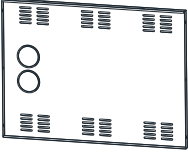
<p>17. Right side cabinet panel</p> 	<p>18. Side cabinet panel support x4</p> 	<p>19. Magnet plate x2</p> 	<p>20. Castor without lock x2</p> 
<p>21. Castor with lock x 10</p> 	<p>22. Plastic backing board x3</p> 	<p>23. Control knob</p> 	<p>24. Seat of control knob</p> 
<p>25. Grease tray</p> 	<p>26. Smoker box</p> 	<p>27. Grease cup</p> 	<p>28. Hood handle</p> 
<p>29. Side burner trivet</p> 	<p>30. Right side burner table</p> 	<p>31. Left side panel of right side cabinet</p> 	<p>32. Right side panel of right side cabinet</p> 

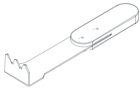

PARTS LIST

<p>33. Bottom panel of right side cabinet</p> 	<p>34. Crossbeam of right side cabinet</p> 	<p>35. Back panel of right side cabinet</p> 	<p>36. Fixed regulator plate</p> 
<p>37. Left side table</p> 	<p>38. Left side panel of left side cabinet</p> 	<p>39. Right side panel of left side cabinet</p> 	<p>40. Bottom panel of left side cabinet</p> 
<p>41. Back panel of left side cabinet</p> 	<p>42. Granite table</p> 	<p>43. Tap</p> 	<p>44. Water pipe</p> 
<p>45. Scraper tool</p> 	<p>46. Regulator set</p> 		

HARDWARE PACK

A	Bolt: M6*12 	146	B	Washer: M6 	48
C	Spring Washer: M6 	48	D	Bolt: M5*10 	2
E	Bolt: M4*12 	15	F	Nut: M4 	9
G	Screwdriver 	1	H	Bolt: M4*10 	30
I	Bolt: M6*25 	8			

ASSEMBLY STEPS

Remove all packaging and transit protection materials from parts before assembly. Wear gloves during assembly to protect your hands from cuts and abrasions. Some stages of assembly require a 2 person lift.

STEP 1

Assemble the door magnet panel (19) on the bottom cabinet panel (12) by screw (A) 2pcs as shown.

Assemble the plastic backing board (22) on the bottom cabinet panel (12) by screw (E) 3pcs and Nut (F) 3pcs as shown.

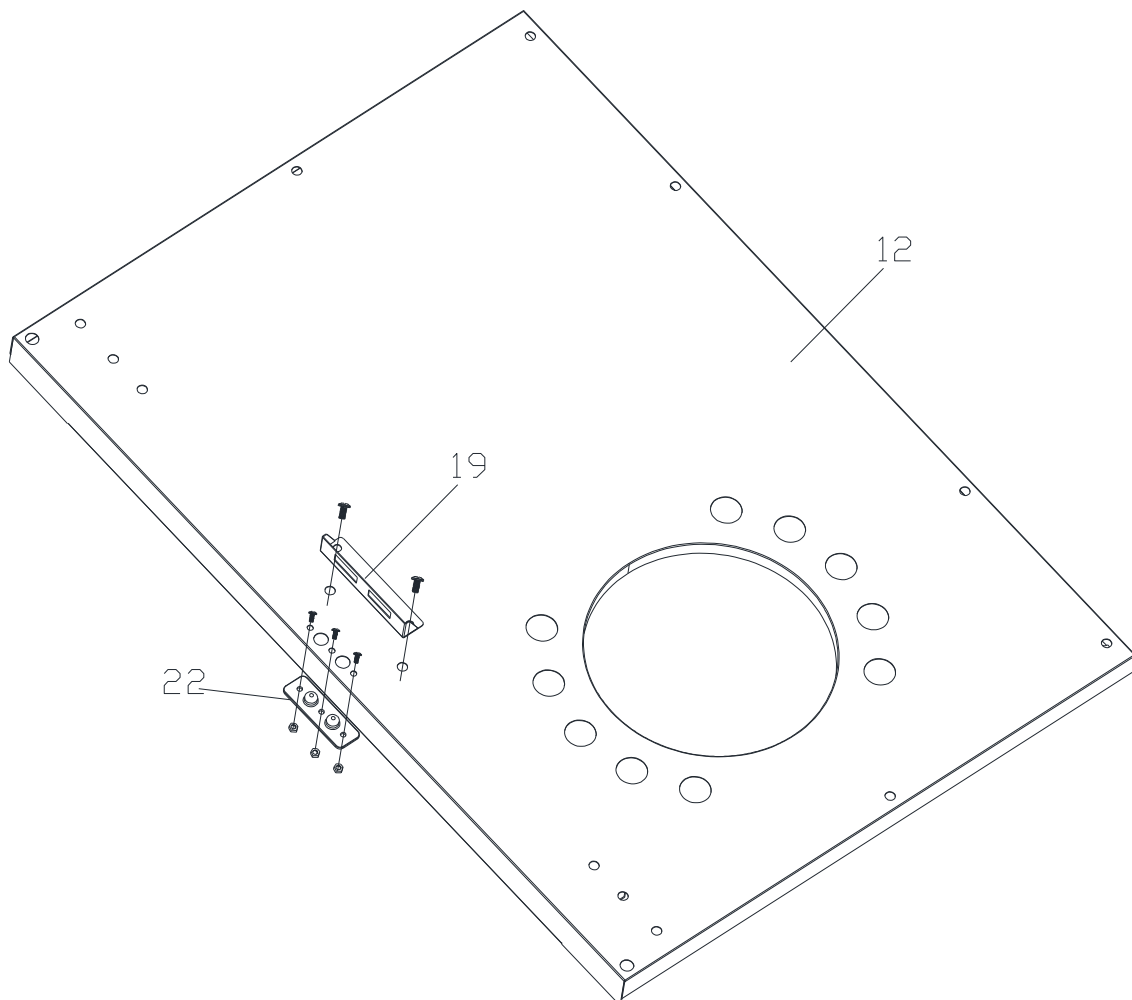

STEP 2

Assemble the castor with lock (21) on the bottom cabinet panel (12) by bolt (A), spring washer (C), washer (B) each 16pcs as shown.

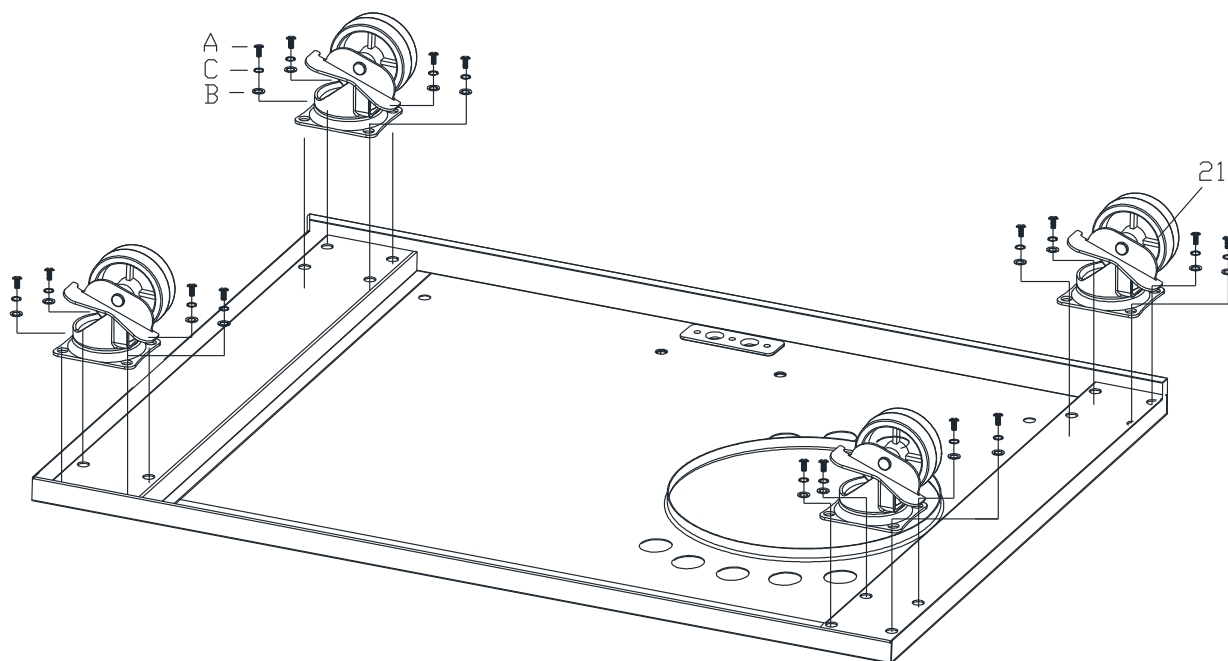

STEP 3

Assemble left door hinge - upper (6) and left door hinge - lower (7) on the left side cabinet panel (10) and assemble right door hinge - upper (8) and right door hinge - lower (9) on the right side cabinet panel (17) by bolt (H) 12pcs.

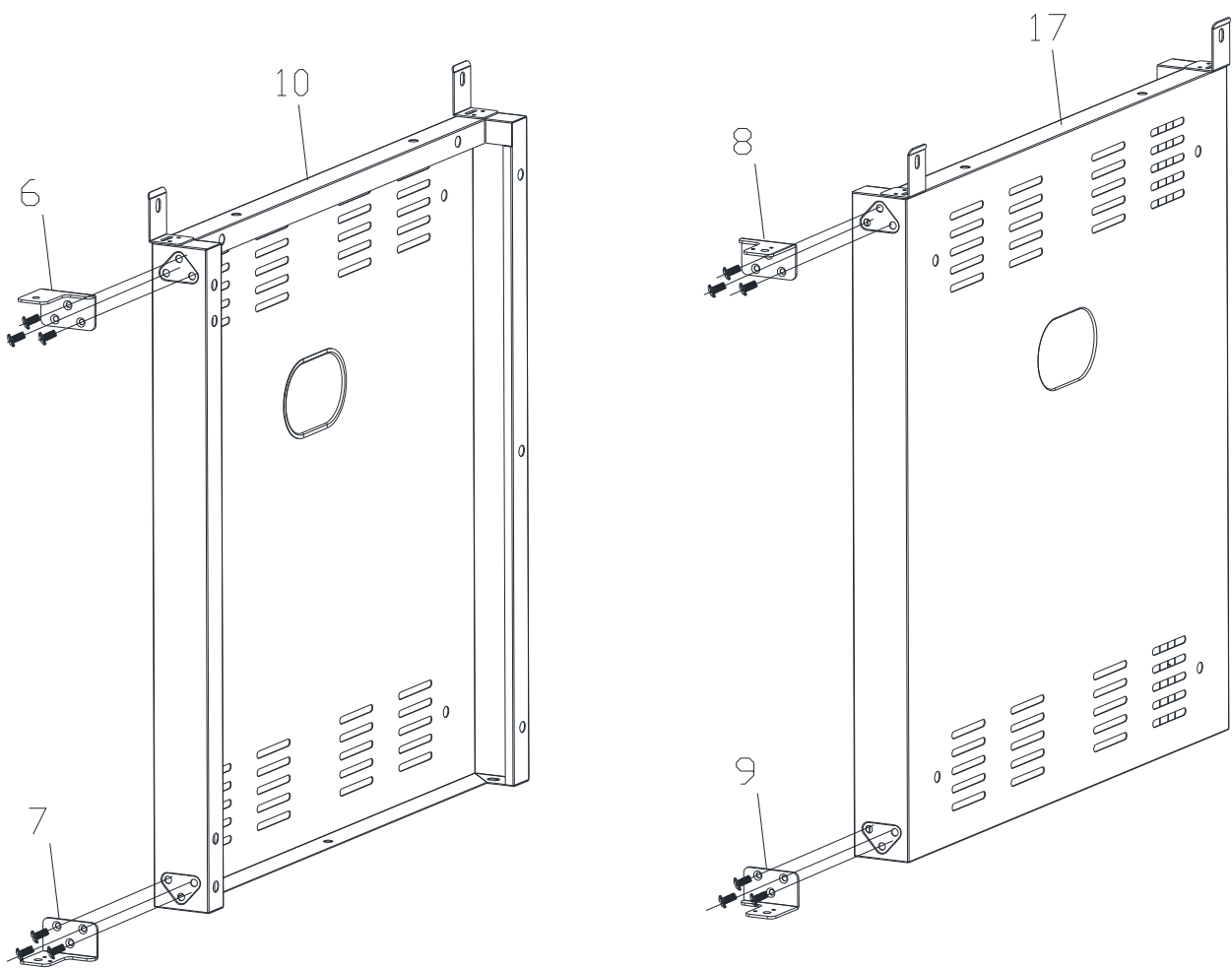

STEP 4

Assemble left side of main cabinet panel (10), back cabinet panel (13) and right side of main cabinet panel (17) on the bottom cabinet panel (12) by bolt (A) 14pcs as shown.

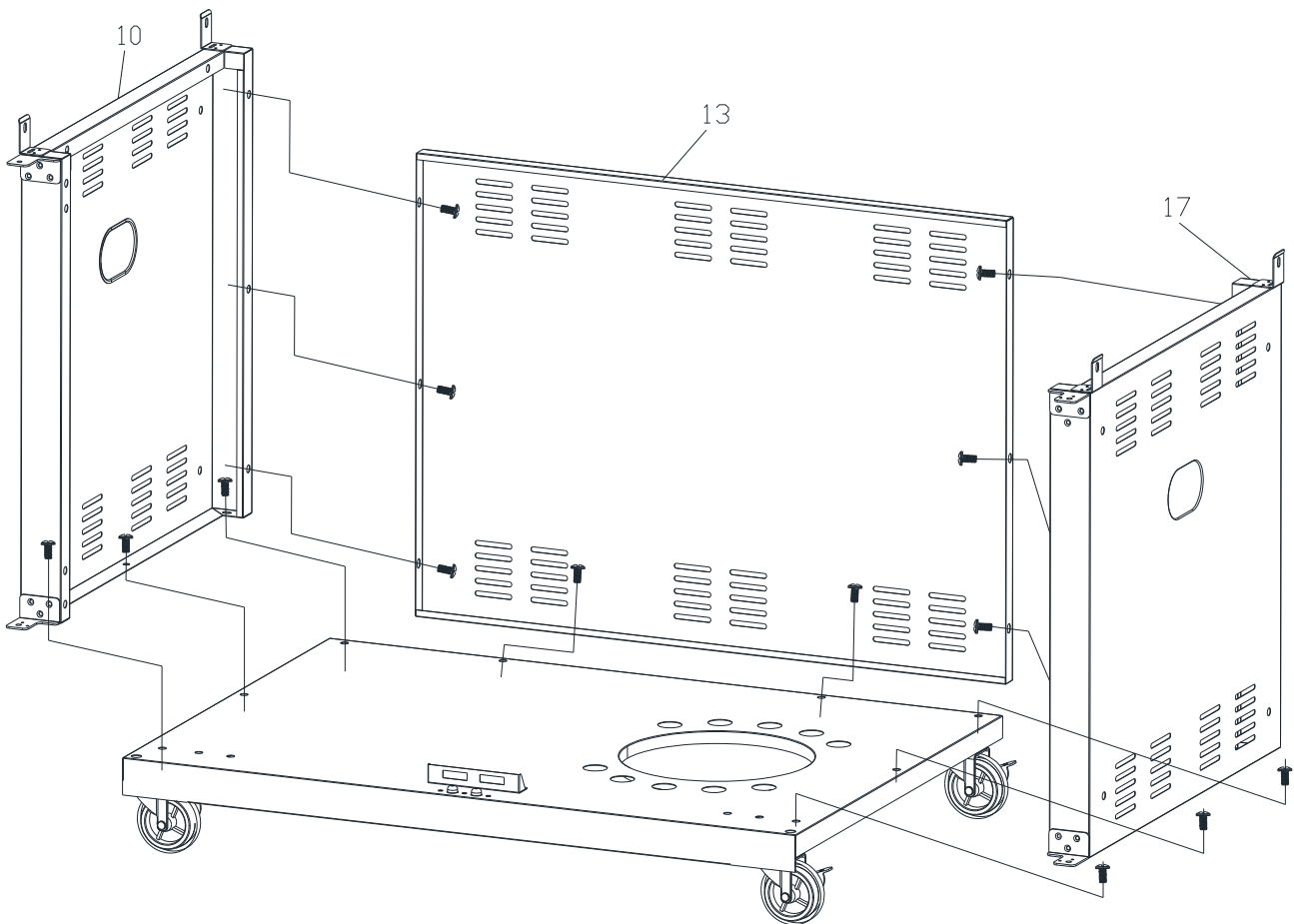

STEP 5

Assemble side cabinet panel support (18) on the bottom panel by bolt (A) 8pcs as shown.

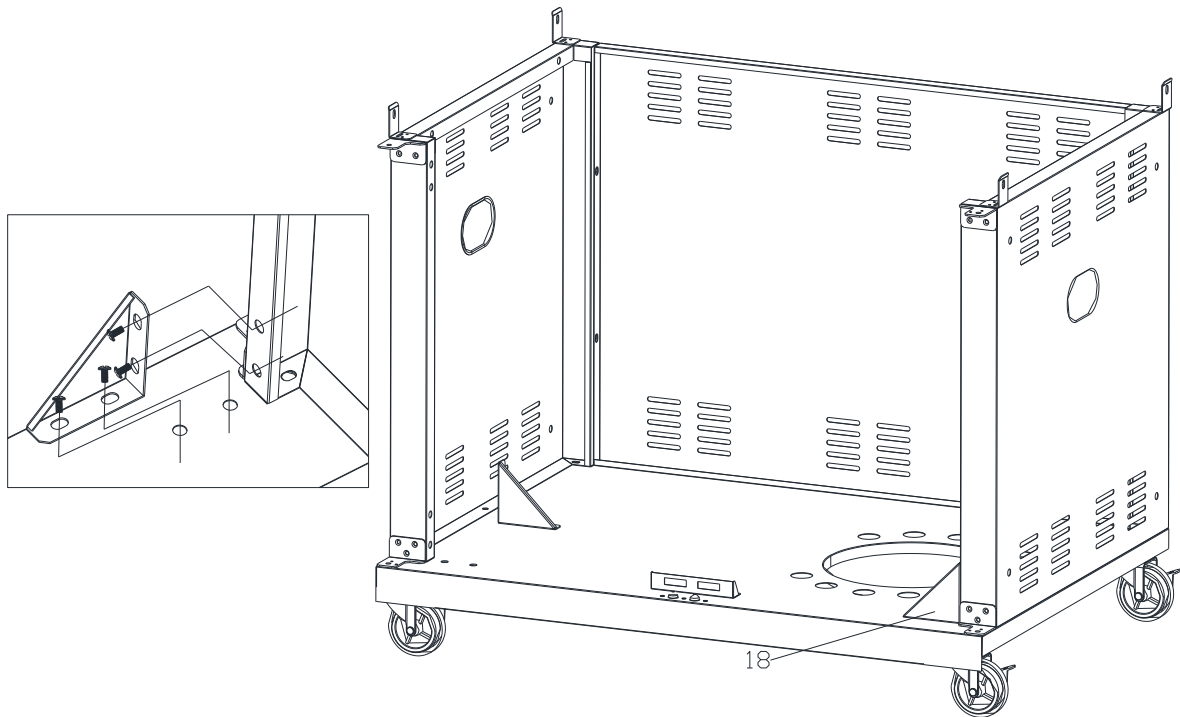

STEP 6

Assemble crossbeam (11) on the cabinet by bolt (A) 4pcs as shown.

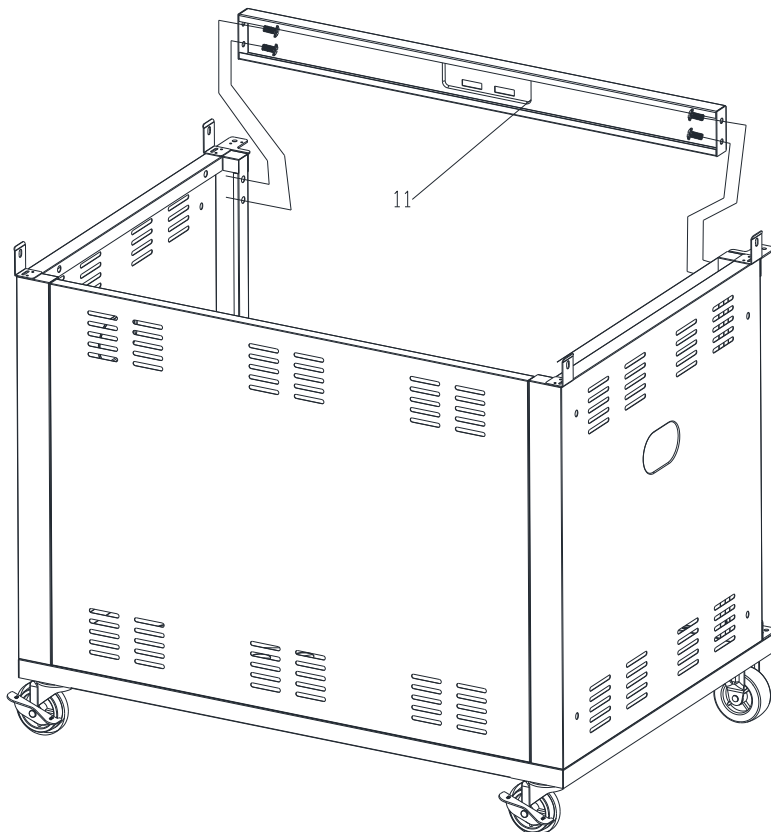

STEP 7

Assemble cabinet separation panel (14) on the cabinet by bolt (A) 4pcs as shown.

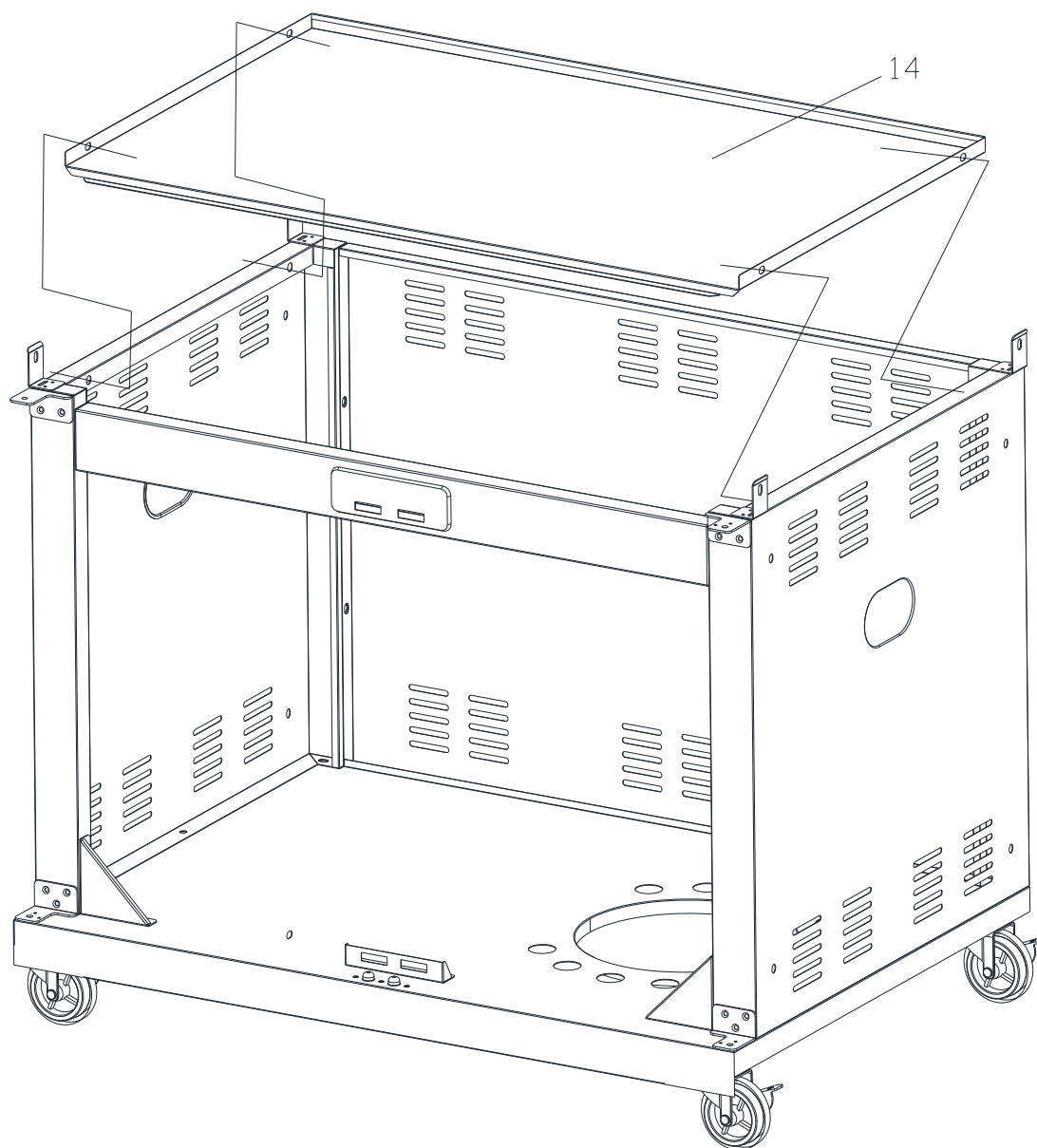

STEP 8

Assemble left door (15) and right door (16) on the cabinet as shown.

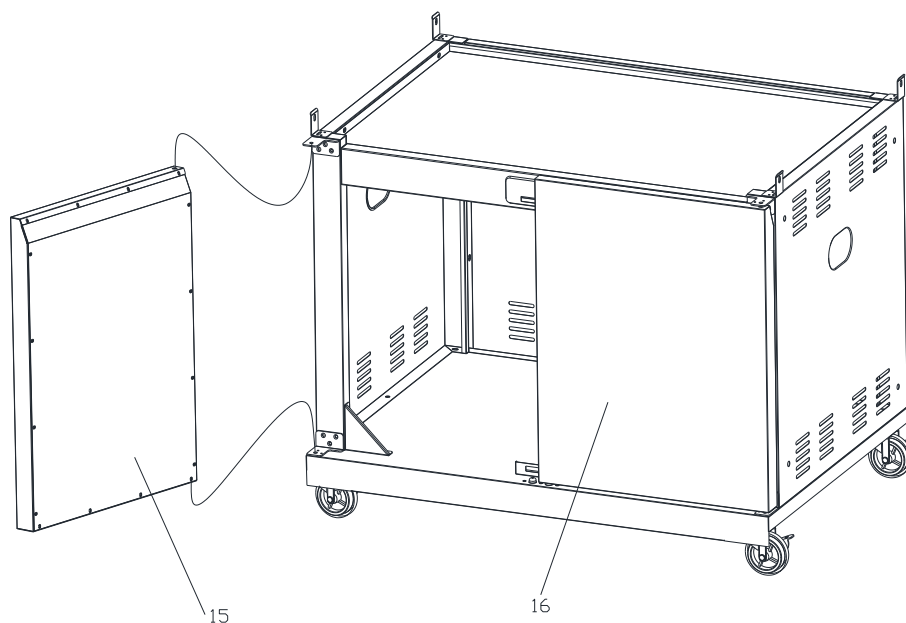

STEP 9

Assemble handle of hood (28) on the hood by bolt (A) 4pcs as shown.

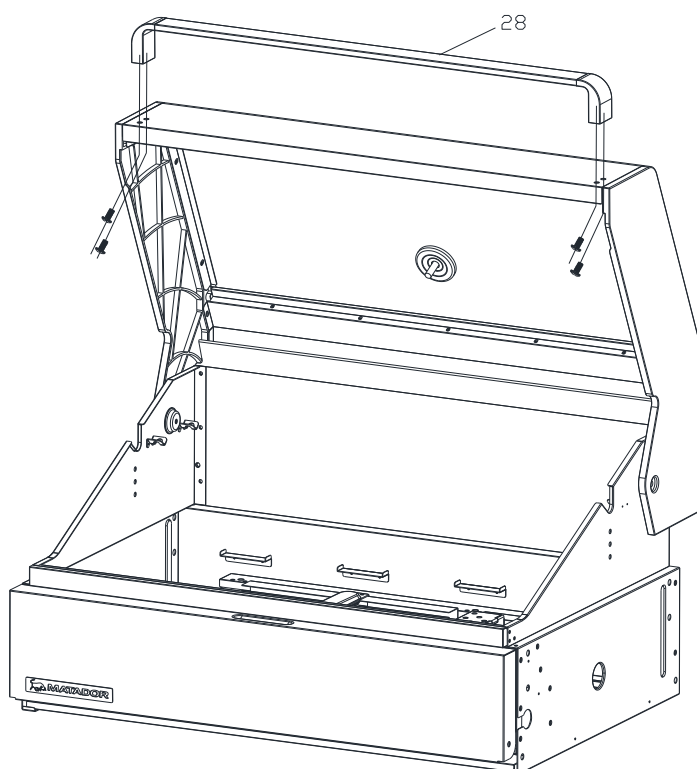

STEP 10

Assemble firebox (4) on the cabinet by bolt (A) 4pcs as shown.

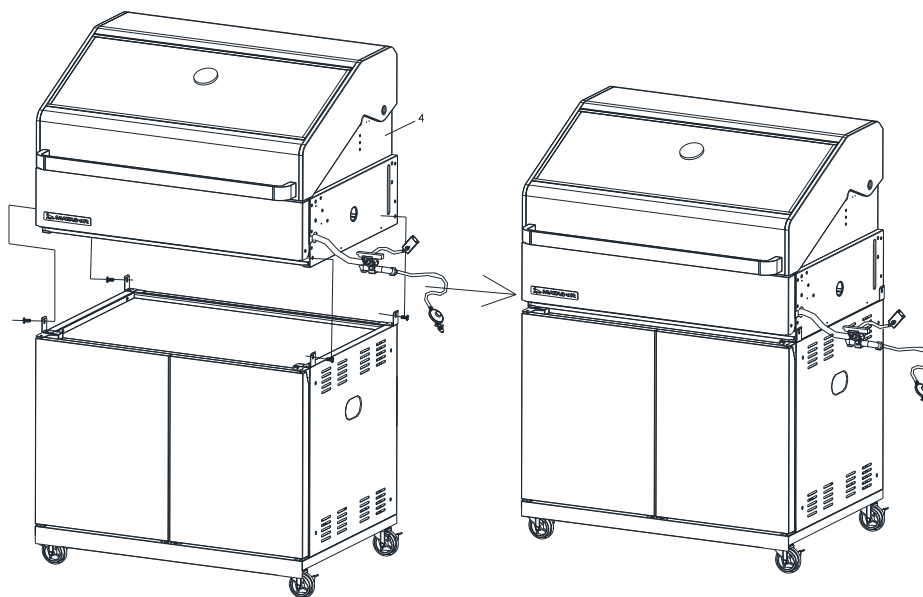

STEP 11

Assemble the door magnet panel (19) on the bottom panel of left side cabinet (40) by bolt (A) 2pcs as shown.

Assemble the plastic backing board (22) on the bottom panel of left cabinet (40) by bolt (E) 3pcs and Nut (F) 3pcs as shown.

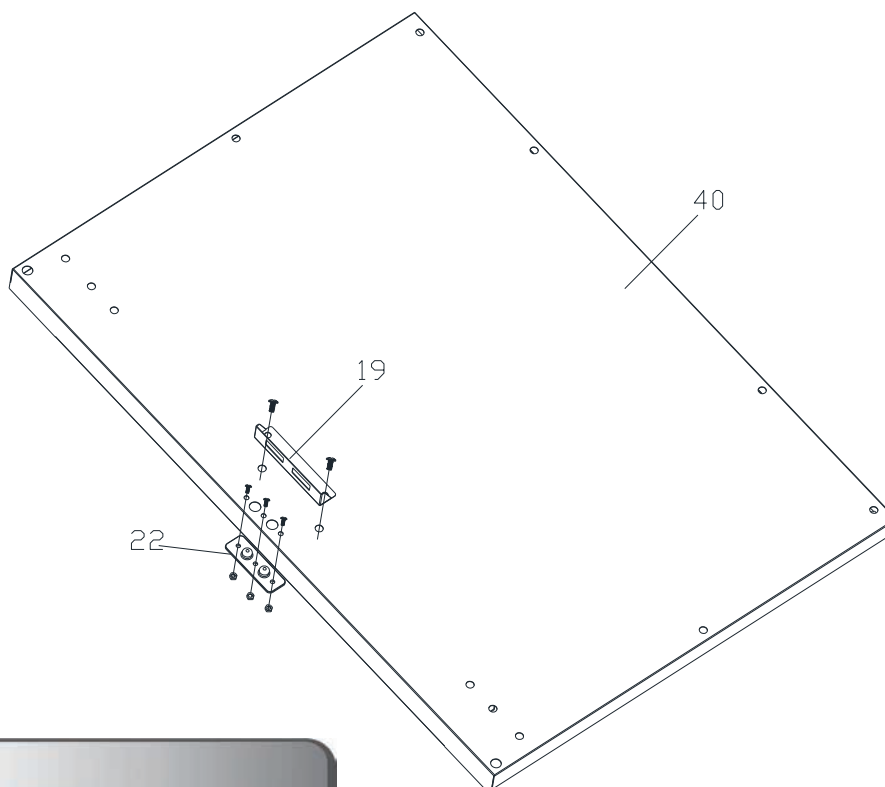

STEP 12

Assemble the castor with lock (21) on the bottom panel of left side cabinet (40) by bolt (A), spring washer (C), washer (B) each 16pcs as shown.

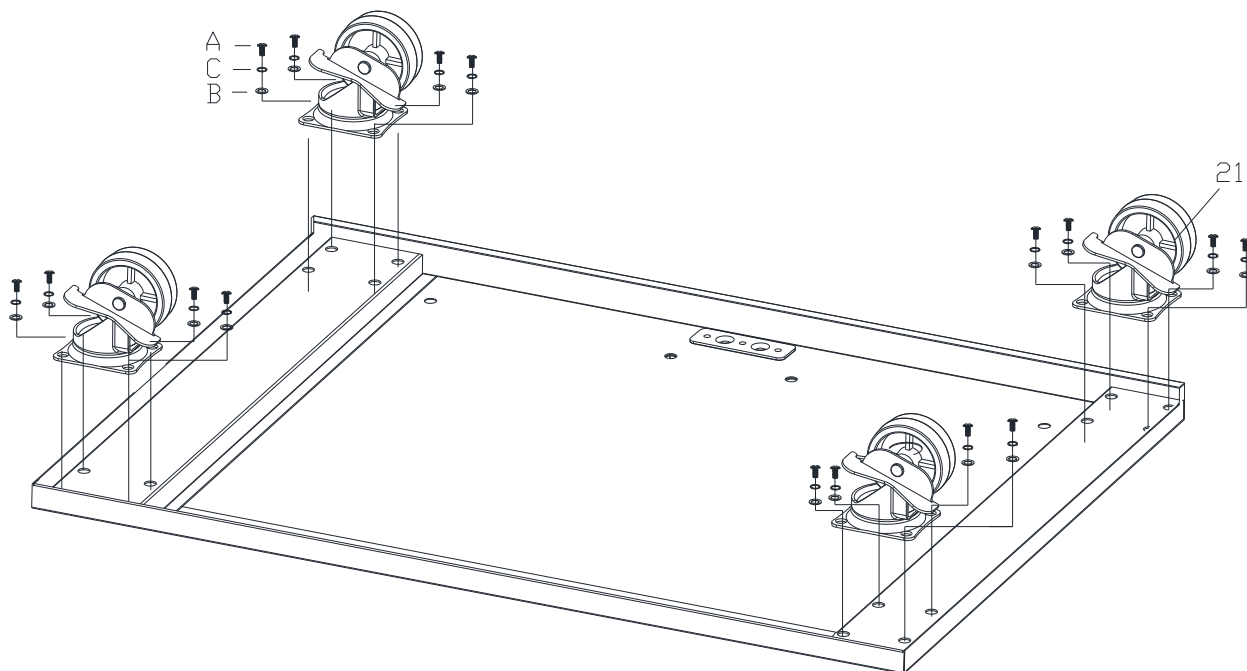

STEP 13

Assemble left door hinge-upper (6) and left door hinge-lower (7) on the left side panel of left side cabinet (38) and assemble right door hinge-Upper (8) and right door hinge-lower (9) on the right side panel of left cabinet (17) by bolt (H) 12pcs.

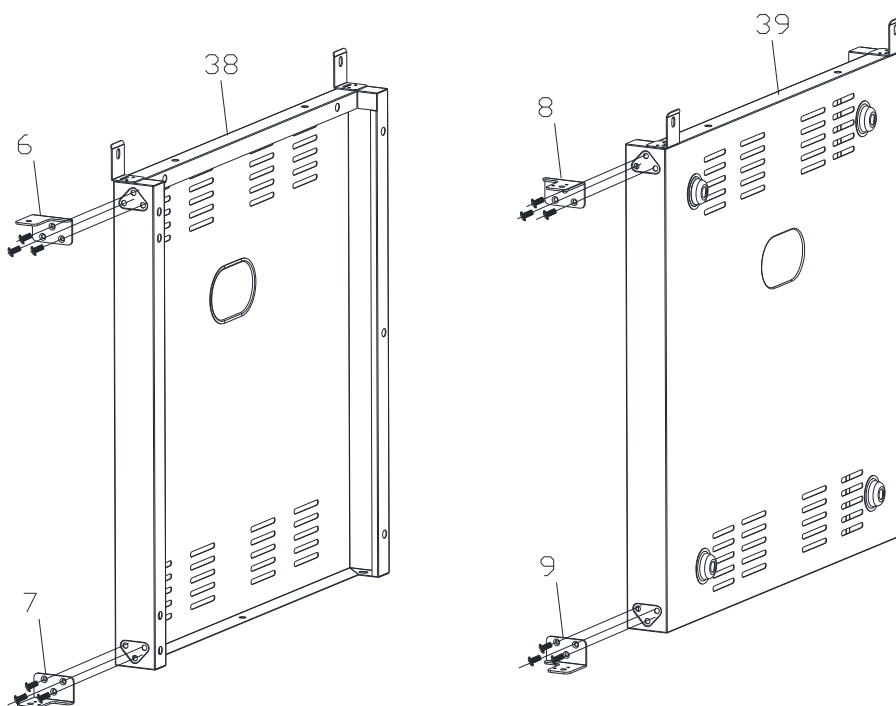

STEP 14

Assemble left side panel of left side cabinet (38), back panel of left side cabinet (41) and right side panel of left cabinet (39) on the bottom panel of left cabinet (40) by bolt (A) 14pcs as shown.

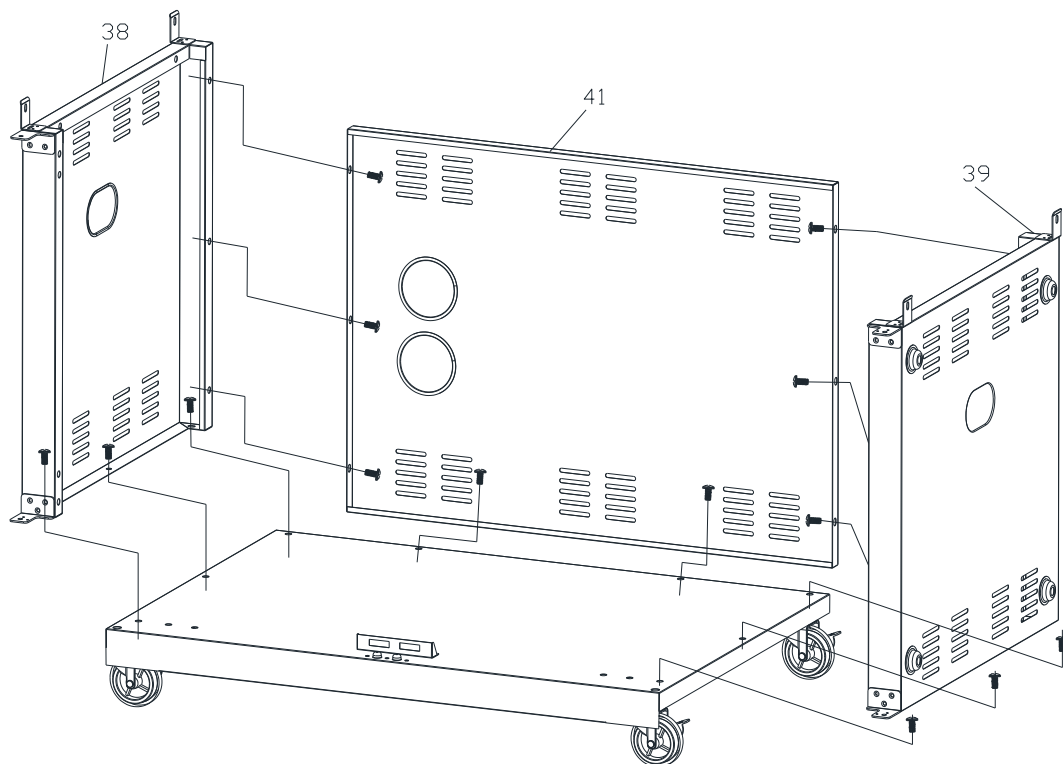

STEP 15

Assemble side cabinet panel support (18) on the bottom panel of left side cabinet (40) by bolt (A) 8pcs as shown.

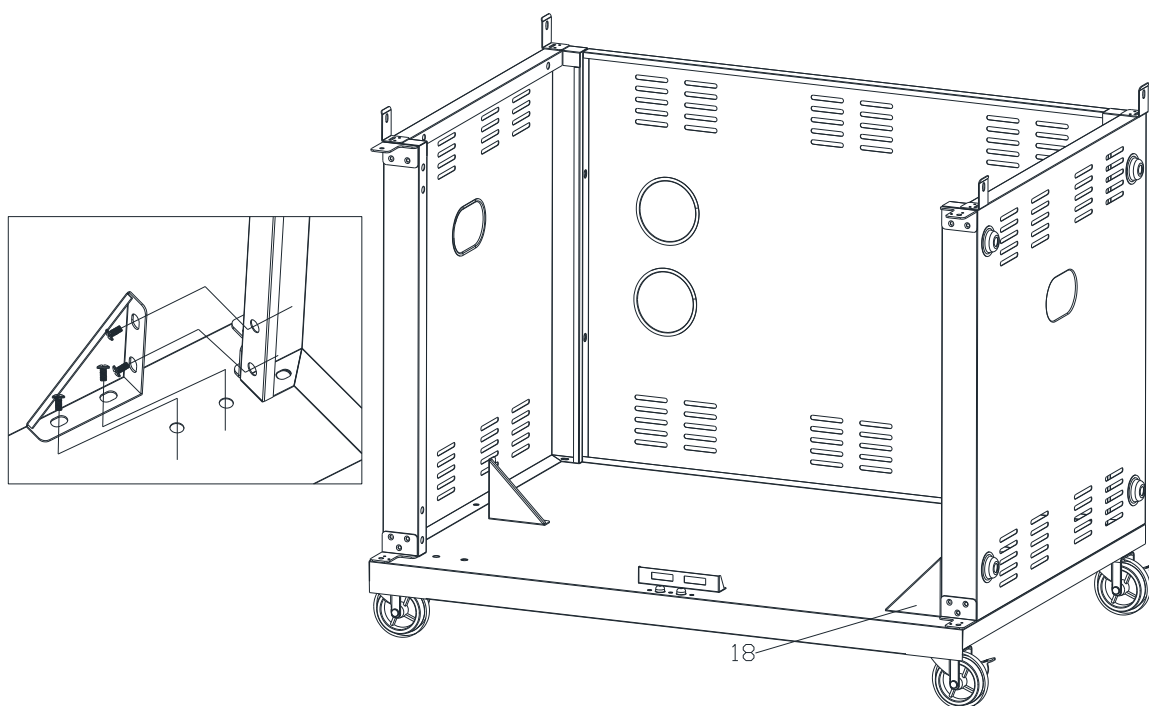

STEP 16

Assemble crossbeam (11) on the left side cabinet by bolt (A) 4pcs as shown.

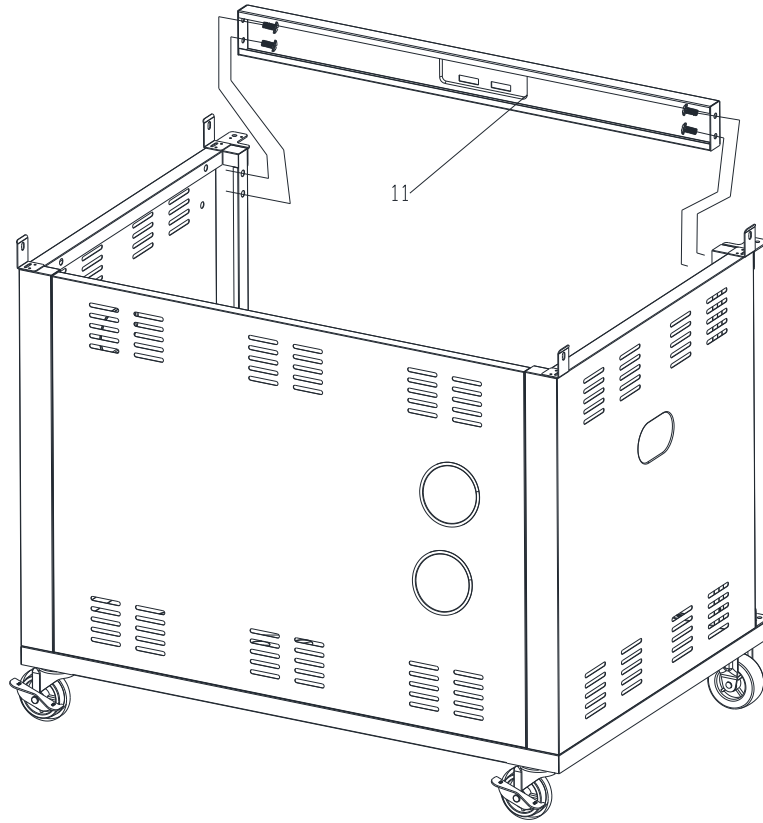

STEP 17

Assemble the water pipe (44) on the sink as shown.

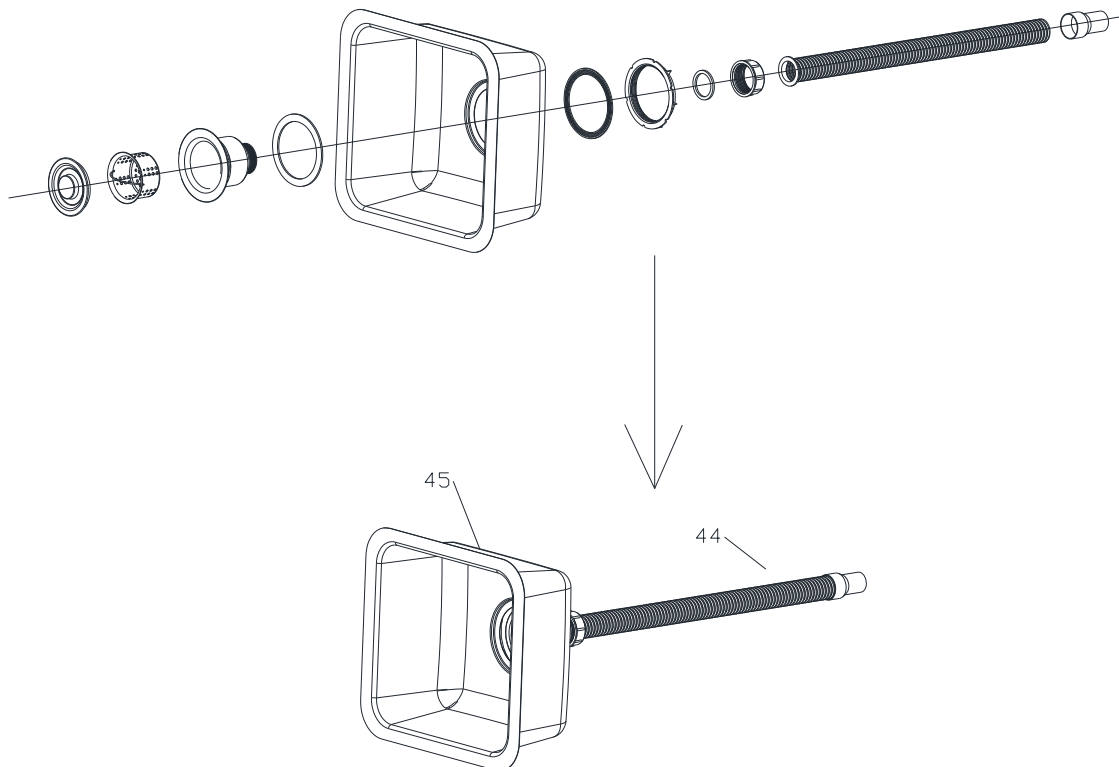

STEP 18

Assemble the left side table (37) on the left side cabinet by bolt (A) 6pcs as shown.

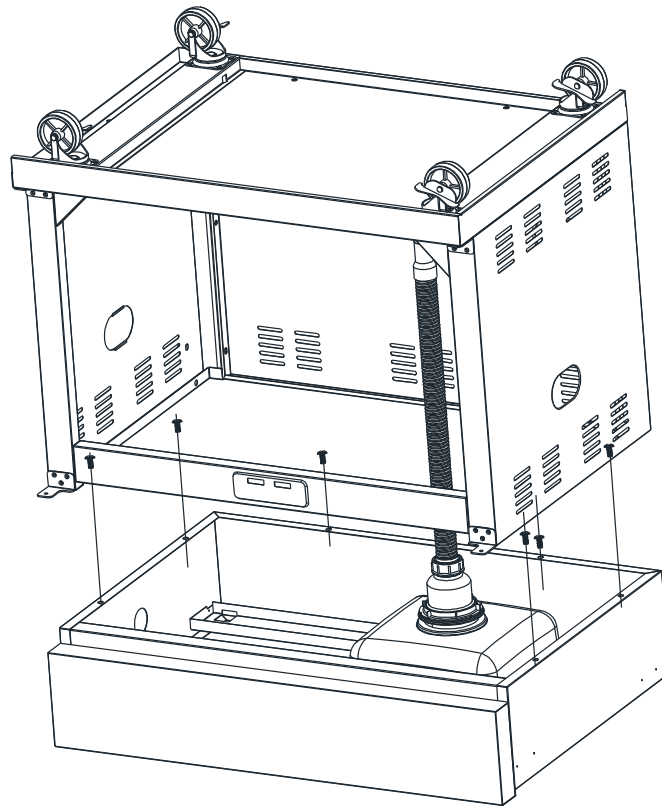

STEP 19

Assemble the left door (15) and right door (16) on the cabinet as shown.

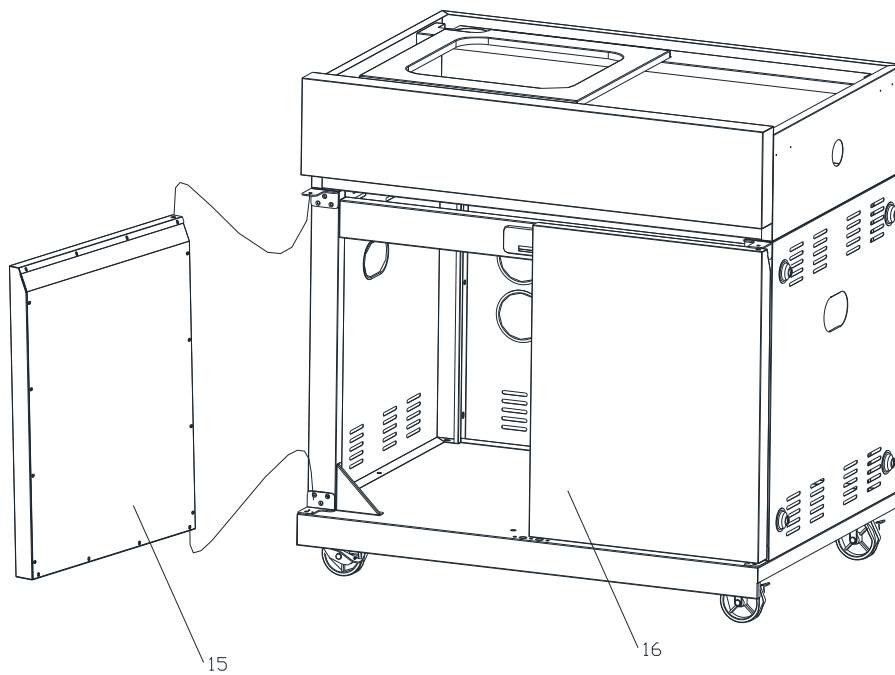

STEP 20

Assemble the tap (43) on the granite table (42) as shown.

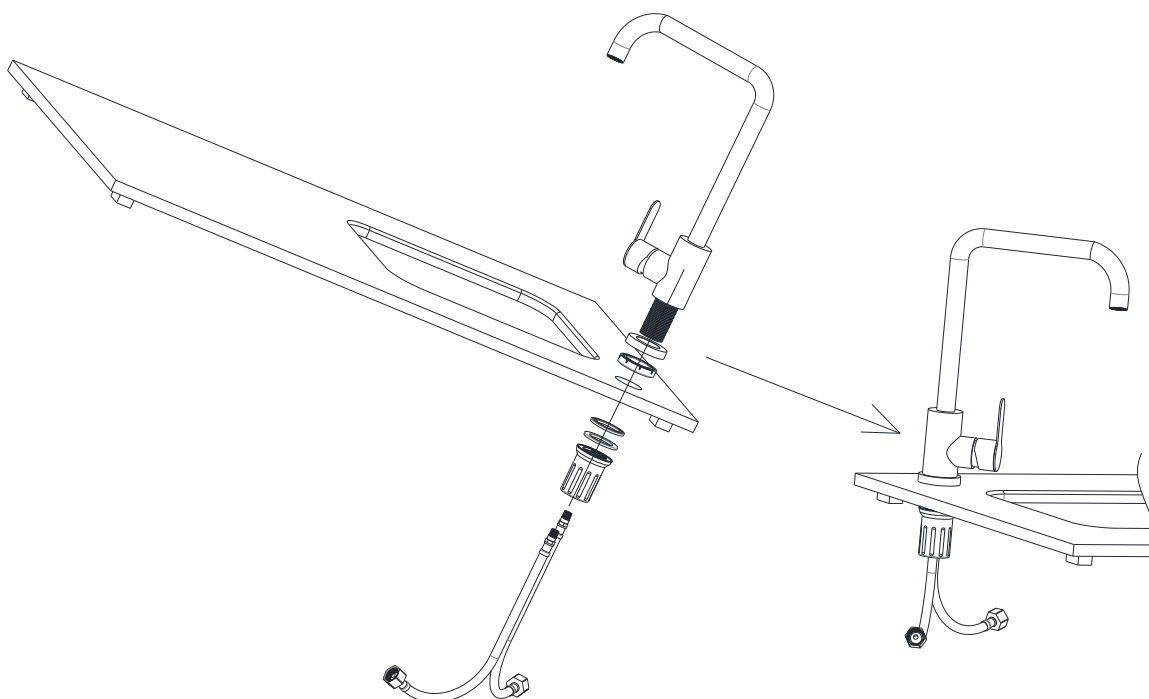

STEP 21

Assemble the granite table and sink on the cabinet as shown.

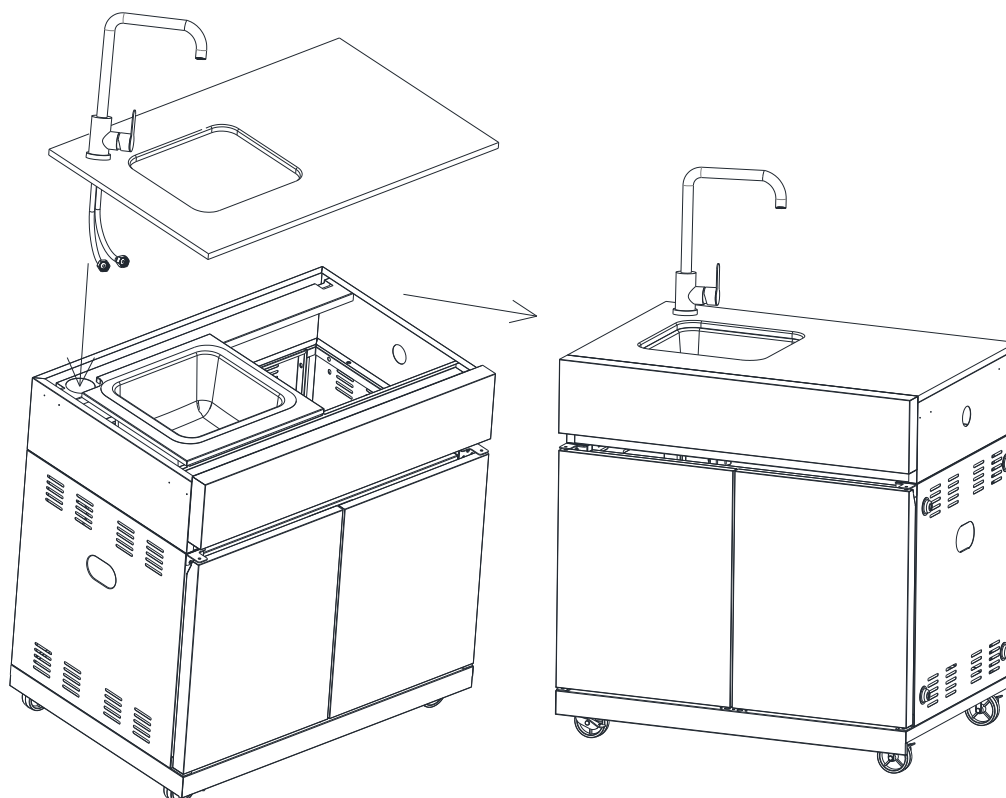

STEP 22

Assemble the plastic backing board (22) on the bottom panel of right side cabinet (33) by bolt (E) 3pcs and nut (F) 3pcs as shown.

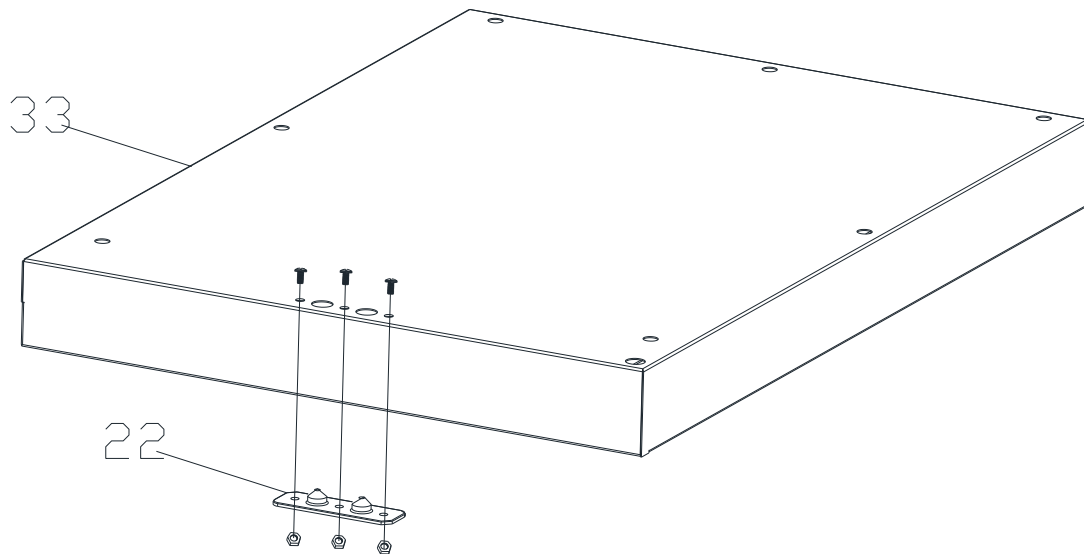

STEP 23

Assemble the castor without lock (20) and castor with lock (21) on the bottom panel of right side cabinet (33) by bolt (A), spring washer (C), washer (B) each 16pcs as shown.

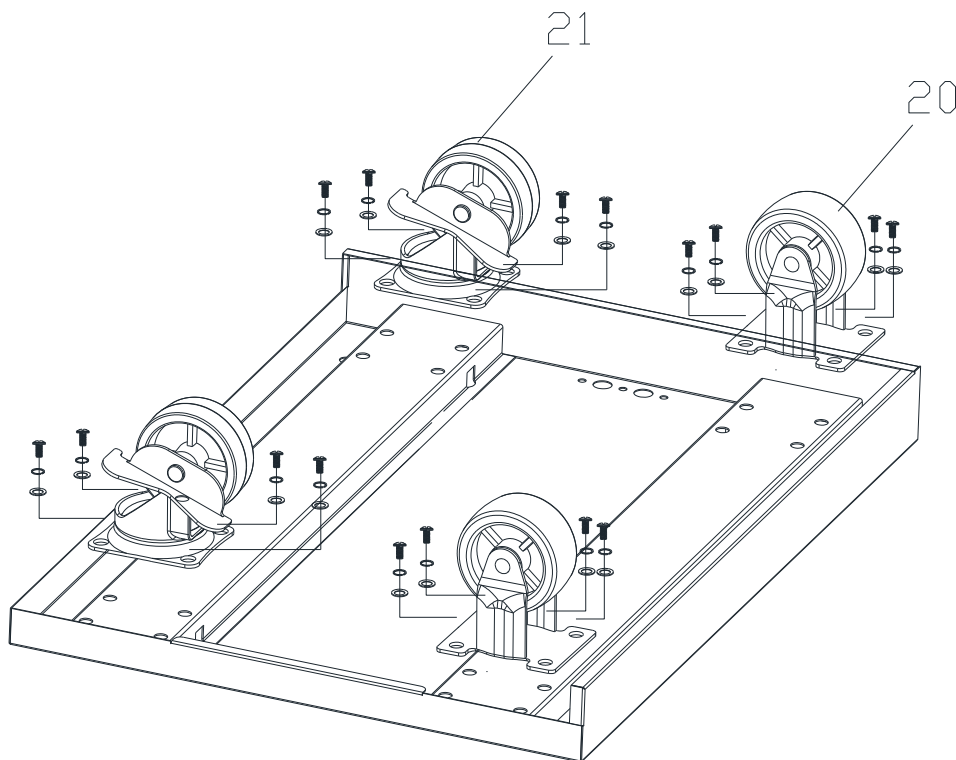

STEP 24

Assemble right door hinge-upper (8) and right door hinge-lower (9) on the right side panel of right cabinet (32) by bolt (H) 6pcs.

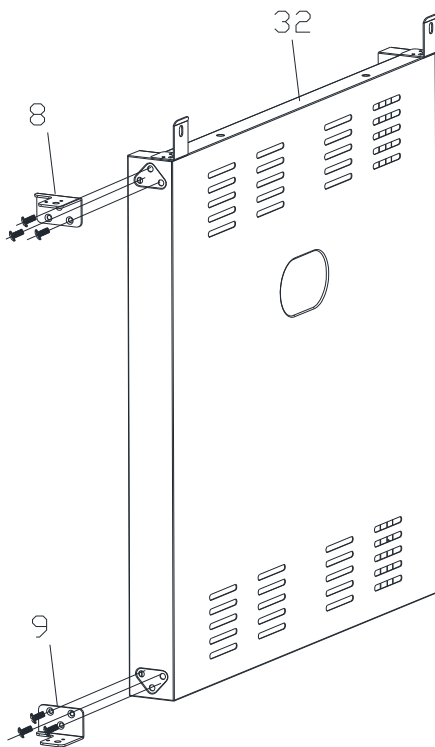

STEP 25

Assemble left side panel of right side cabinet (31), back panel of right side cabinet (35) and right side panel of right cabinet (32) on the bottom panel of right cabinet (33) by bolt (A) 14pcs as shown.

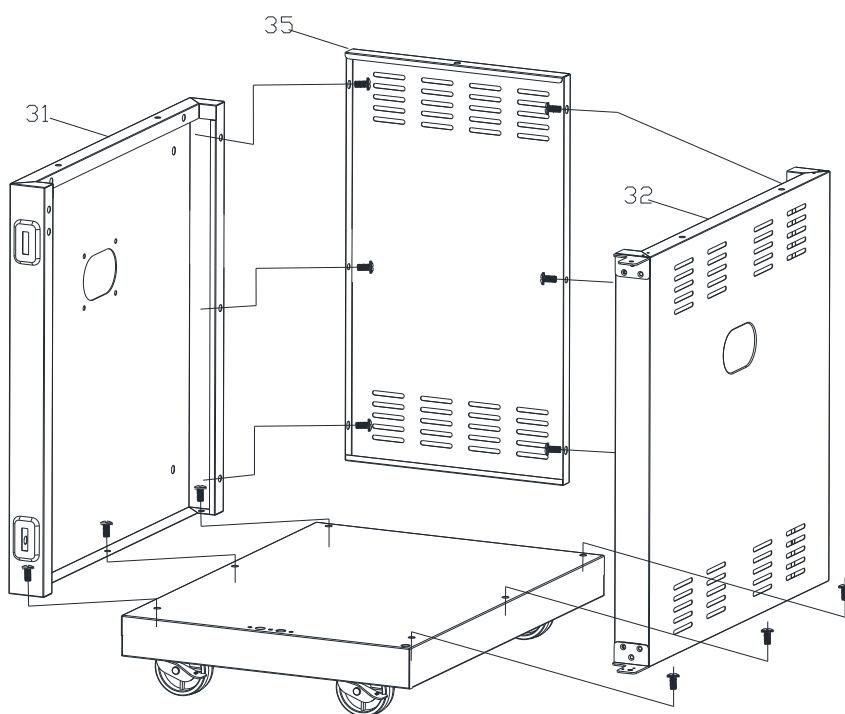

STEP 26

Assemble crossbeam (34) on the right side cabinet by bolt (A) 4pcs as shown.

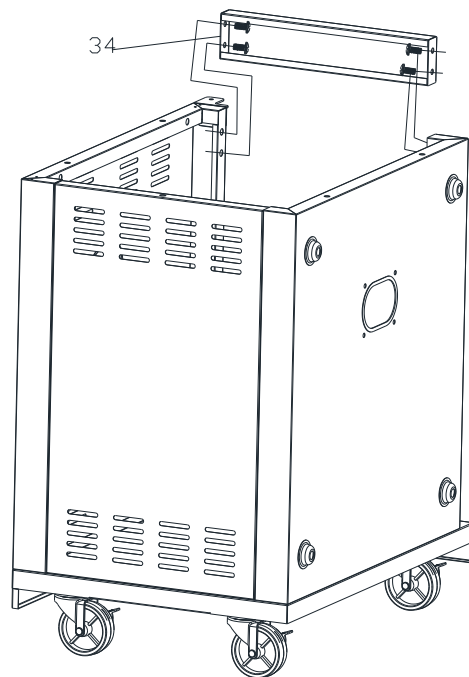

STEP 27

Assemble the right side burner table (30) on the right side cabinet by bolt (A) 5pcs as shown.

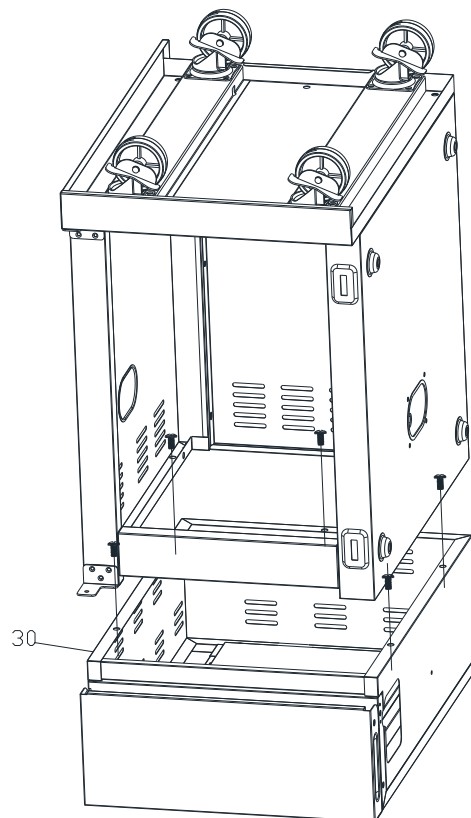

STEP 28

Assemble the right door (16) on the right side cabinet as shown.

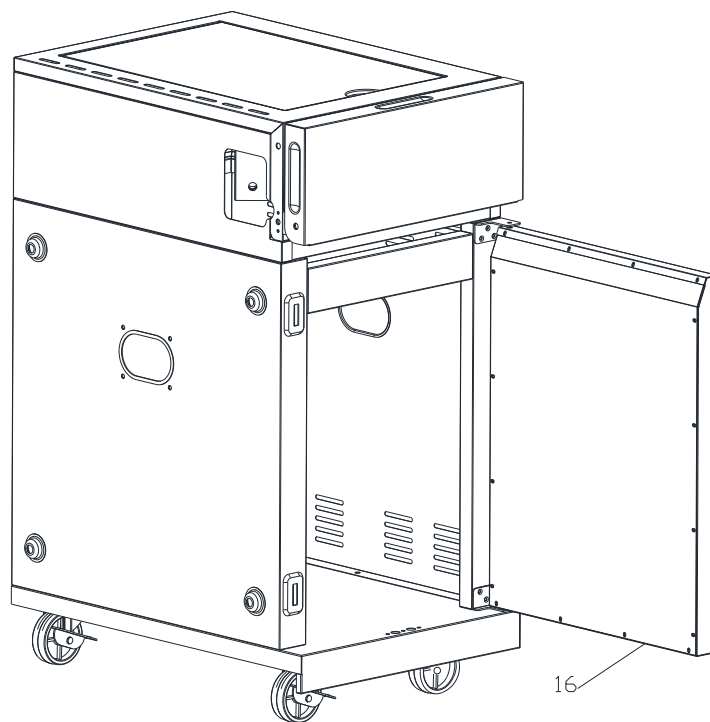

STEP 29

Put the regulator and side valve into right side cabinet square hole as below shown.

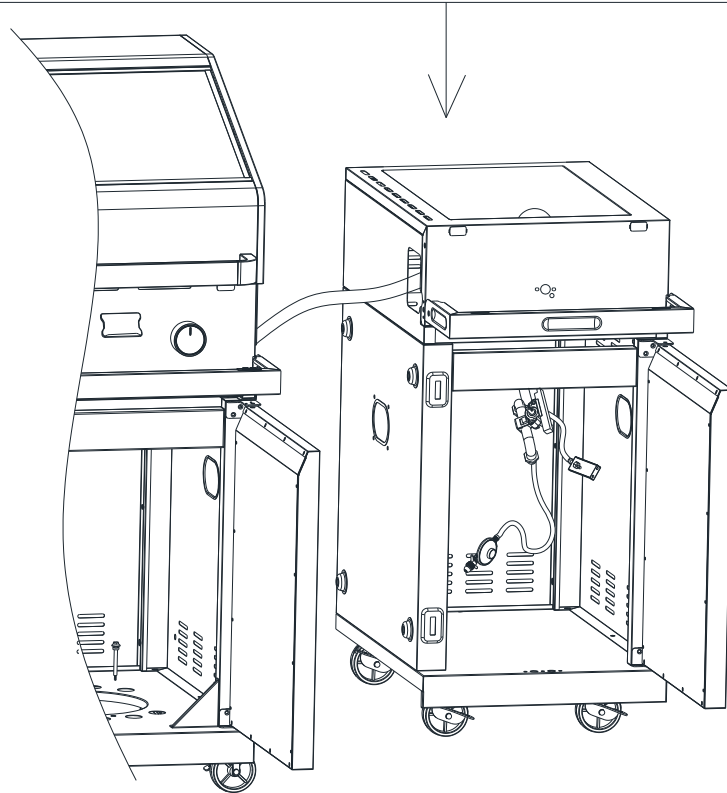
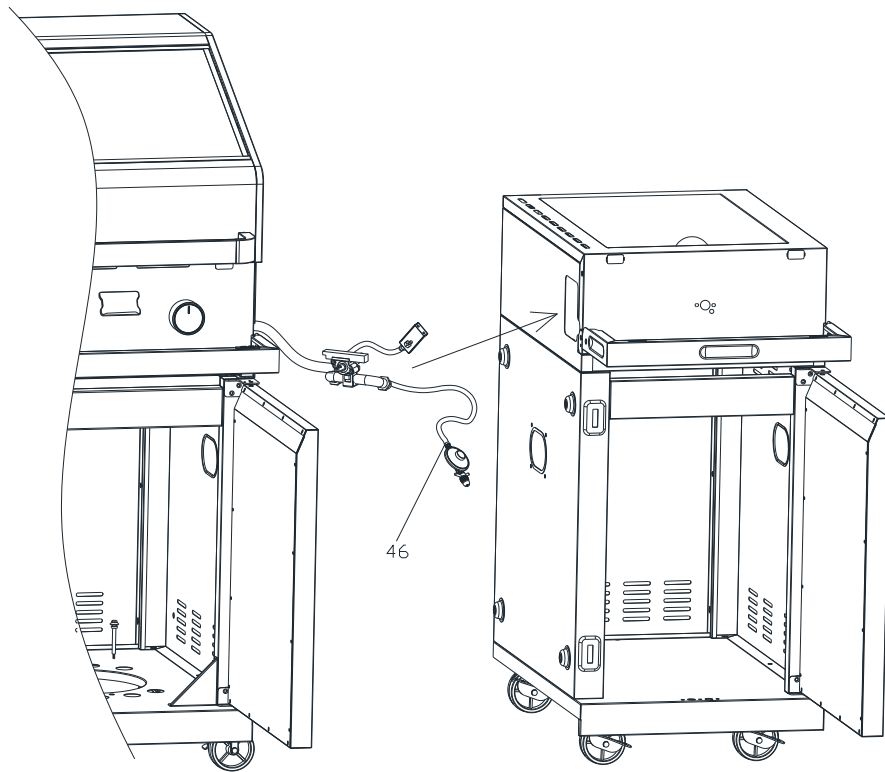

STEP 30

Assemble the left side cabinet and main body and right side cabinet by bolt (I) 8pcs as shown.

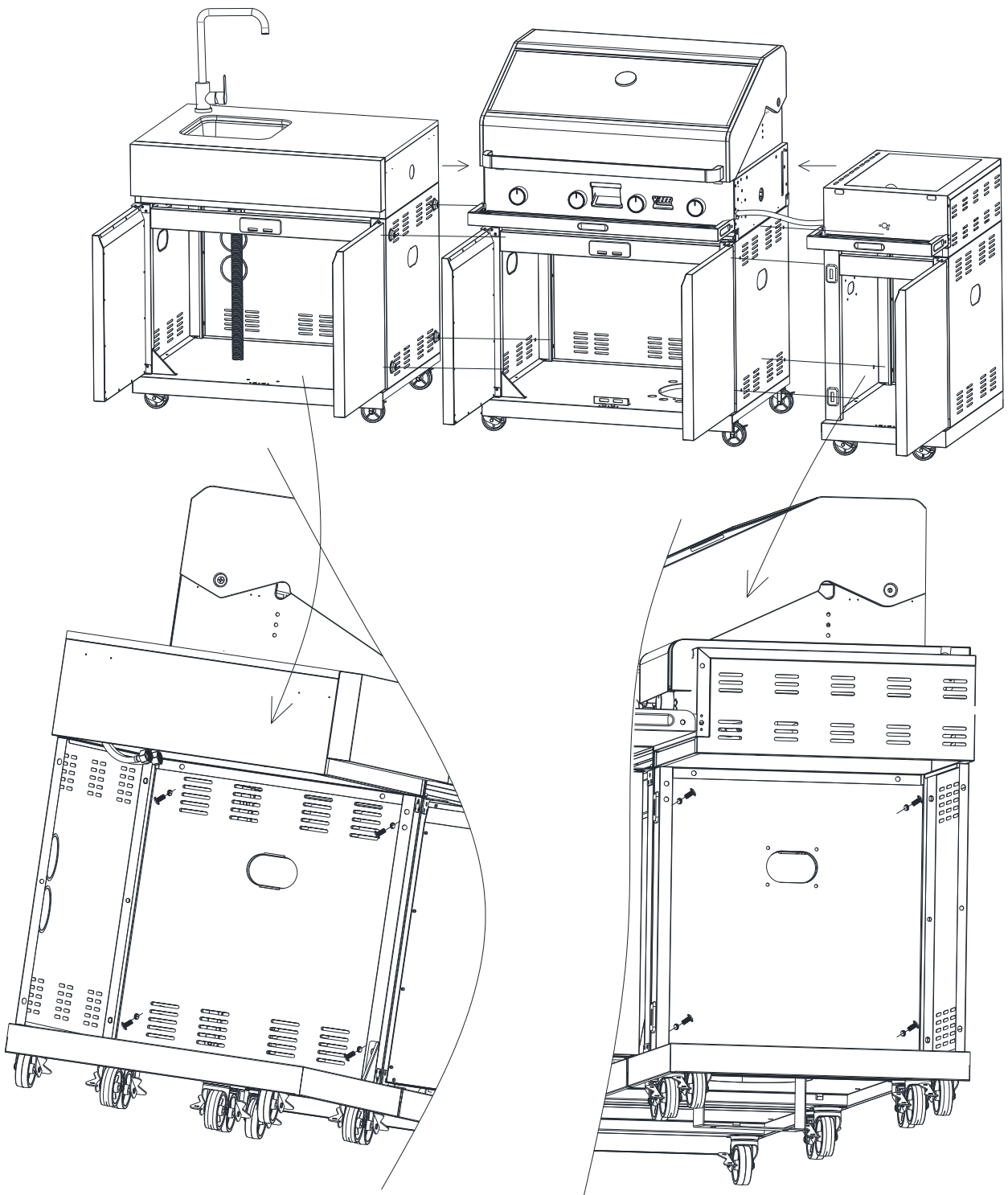

STEP 31

Assemble control knob seat (24) on the side valve by bolt (E) 2pcs as shown, put the control knob (23) on the valve bar as shown.

Insert the ignition wire as shown and put the regulator to main body cabinet from oval hole as shown.

Assemble the injector bracket by screw (D) 2pcs as photo A and B shown.

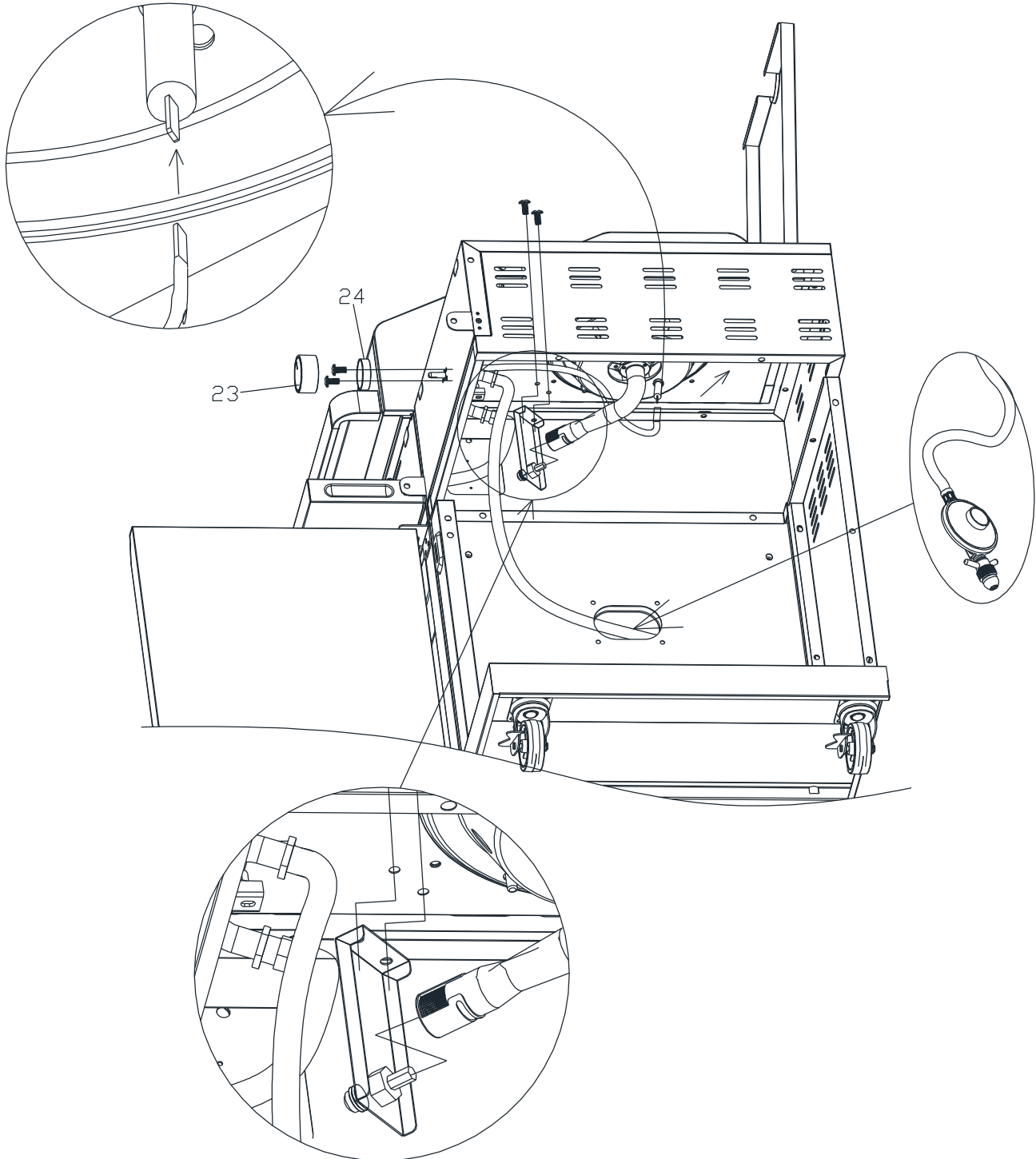

STEP 32

Assemble the fixed regulator plate (36) on the right side cabinet by bolt (E) 4pcs as shown.

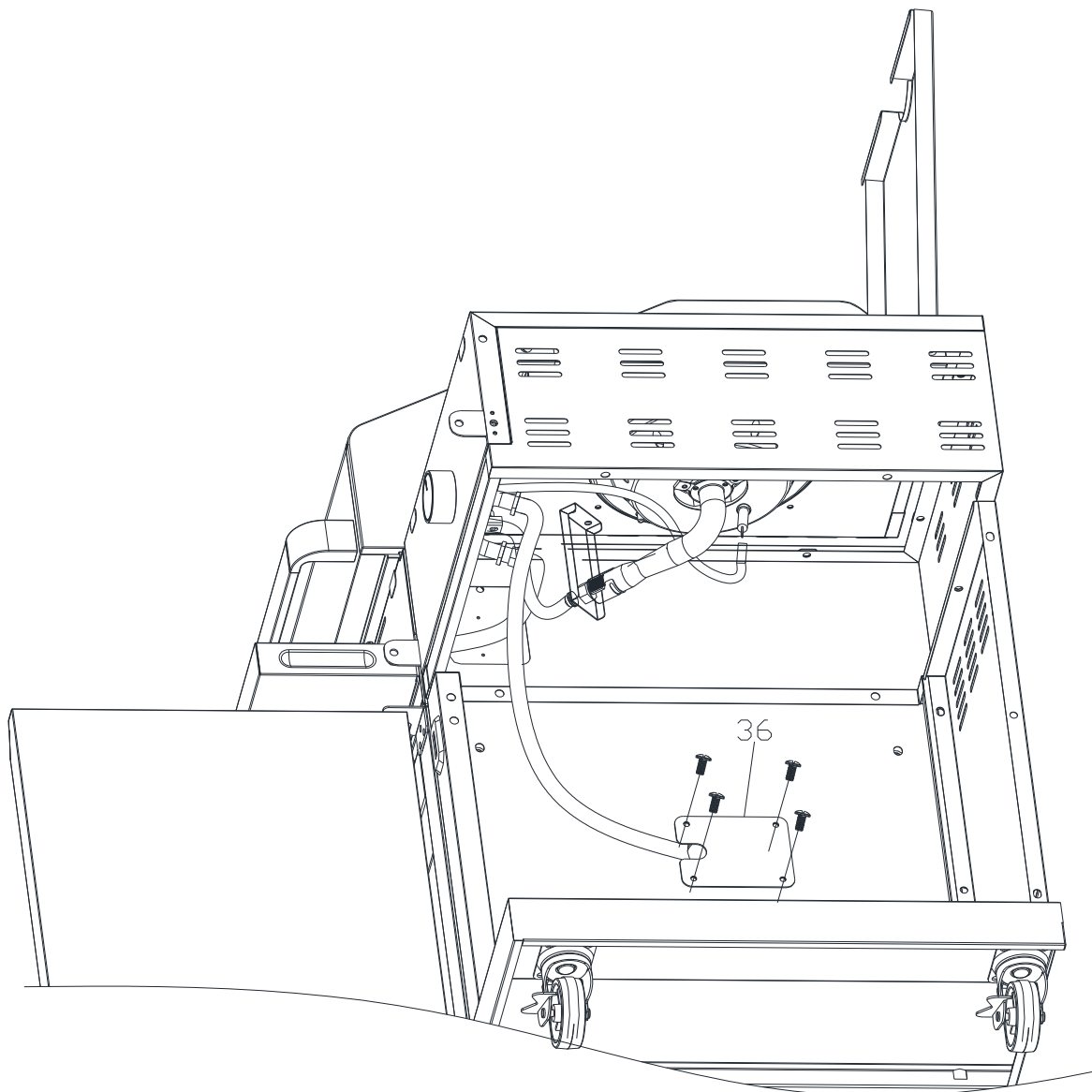

STEP 33

Insert the grease cup (27) and smoker box (26) on the control panel and insert the flame tamer (5) into the firebox as shown.

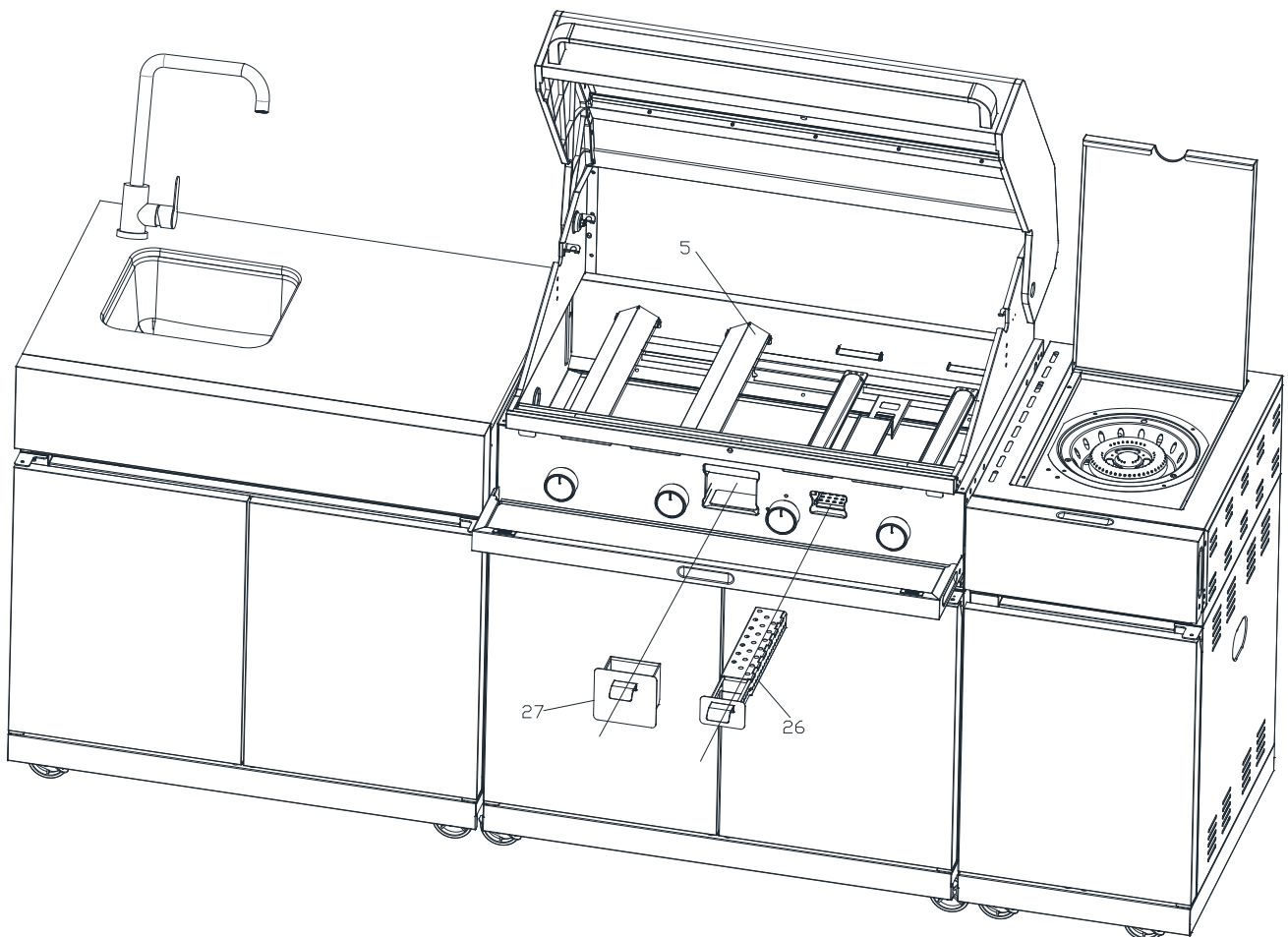

STEP 34

Insert the cooking grill (1) and hotplate (2) on the firebox as shown.

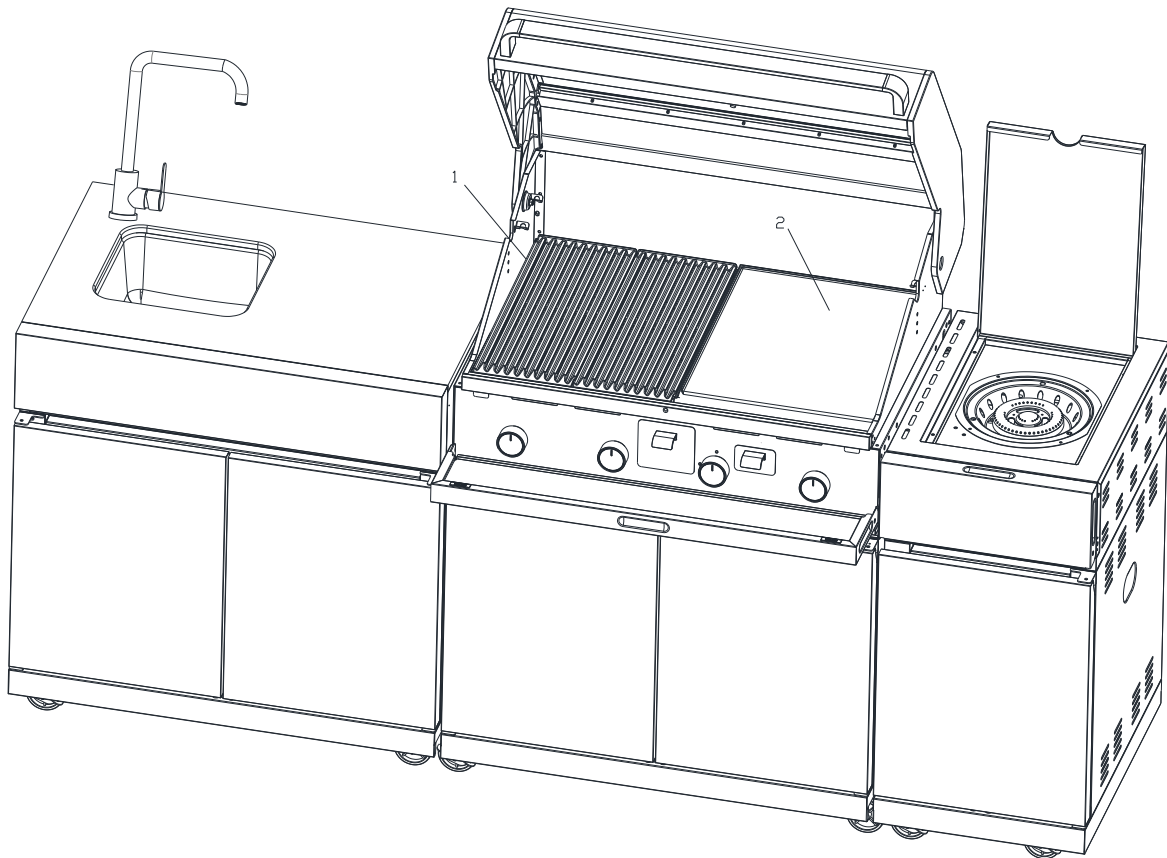

STEP 35

Insert the warming rack (3) and side burner trivet (29) as shown.

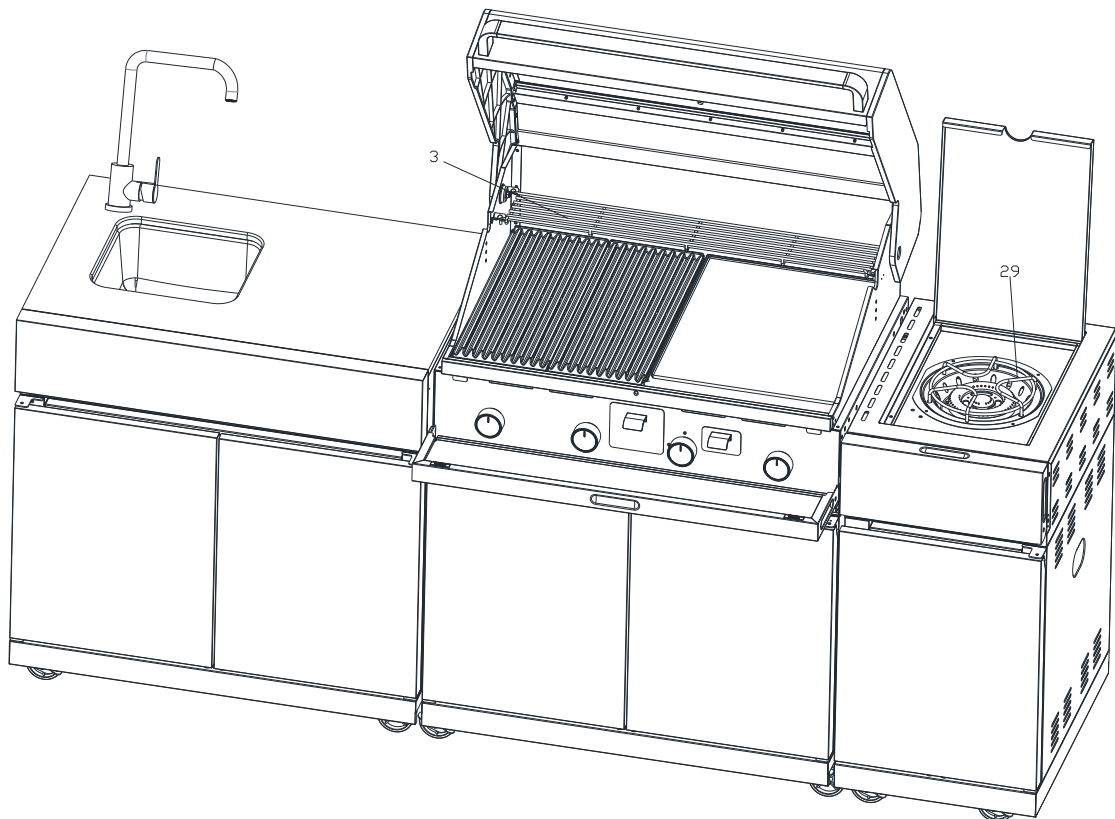

FULLY ASSEMBLED BBQ

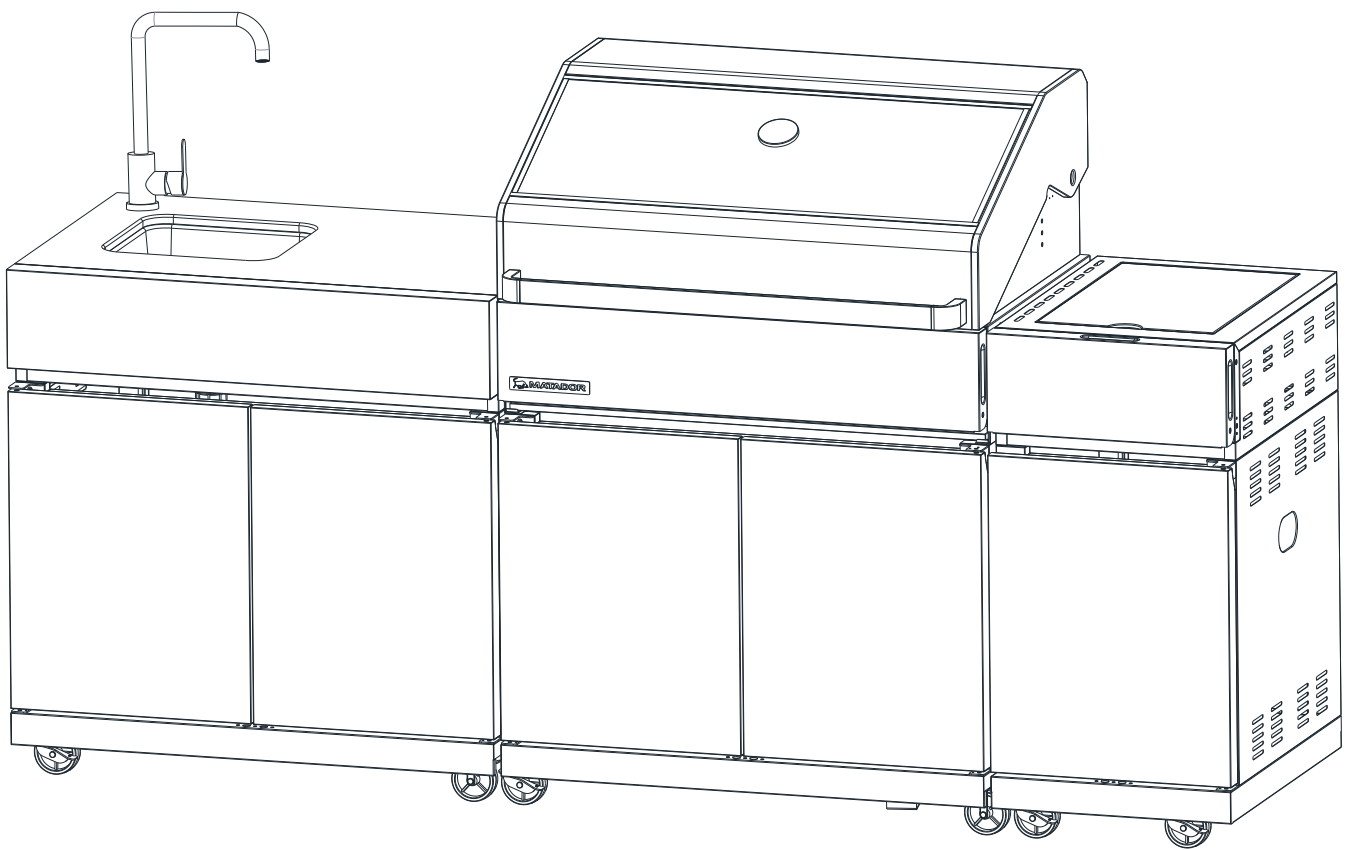

BBQ LOCATION - OUTDOOR AREAS

This appliance shall only be used in an above ground open-air situation with natural ventilation, without stagnant areas, where gas leakage and products of combustion are rapidly dispersed by wind and natural convection.

Any enclosure in which the appliance is used shall comply with one of the following:

- An enclosure with walls on all sides, but at least one permanent opening at ground level and no overhead cover.
- Within a partial enclosure that includes an overhead cover and no more than two walls.
- At least 25% of the total wall area is completely open; and
- At least 30% of the remaining wall area is open and unrestricted.
- In the case of balconies, at least 20% of the total of the side, back and front wall areas shall be and remain open and unrestricted.

Examples of the correct appliance outdoor setups can be seen below.

OUTDOOR AREA
EXAMPLE 1

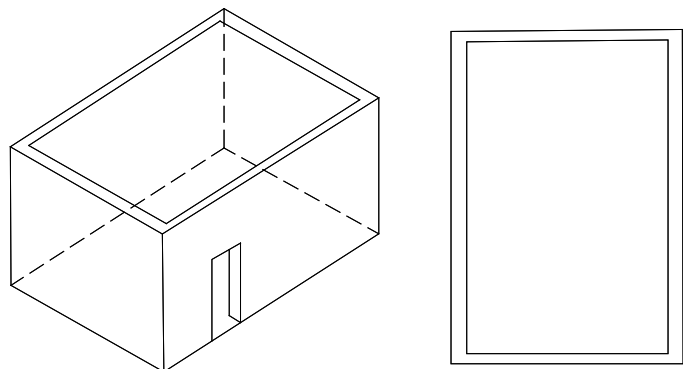

OUTDOOR AREA
EXAMPLE 2

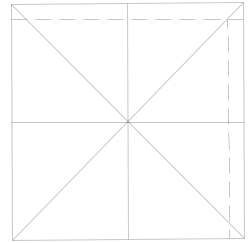
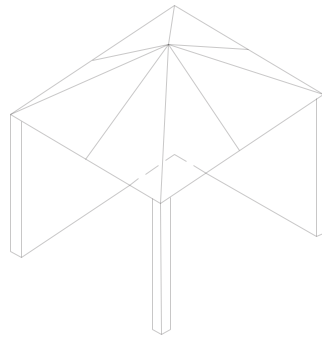

OUTDOOR AREA
EXAMPLE 3

Both ends open

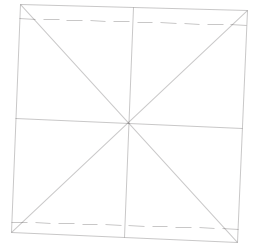
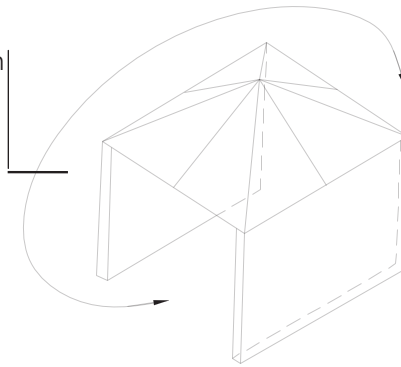

OUTDOOR AREA
EXAMPLE 4

Open sides are at least 25% of total wall area

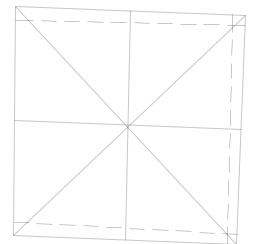
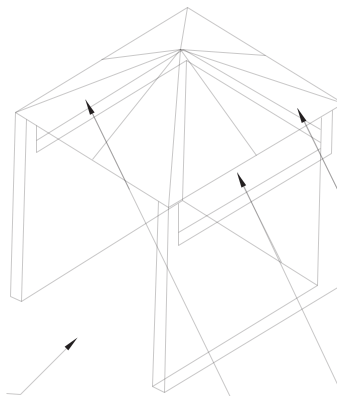

30% or more in total of the remaining wall area is open and unrestricted

OUTDOOR AREA
EXAMPLE 5

Open sides are at least 25% of total wall area

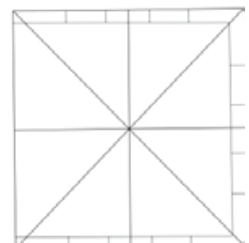
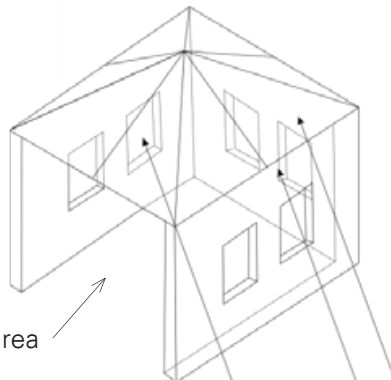

30% or more in total of the remaining wall area is open and unrestricted



CONNECTION TO LPG

GAS LEAK TESTING

Gas leak testing, mentioned earlier in the manual, must be done the first time you connect up the BBQ, and whenever the LPG cylinder is re-connected to the BBQ. Always inspect the hose at regular intervals to check for cracks or abrasion.

CONNECTING THE LPG CYLINDER

1. Connect the regulator to the LPG cylinder and tighten the connection. The two types of connections can be seen below.

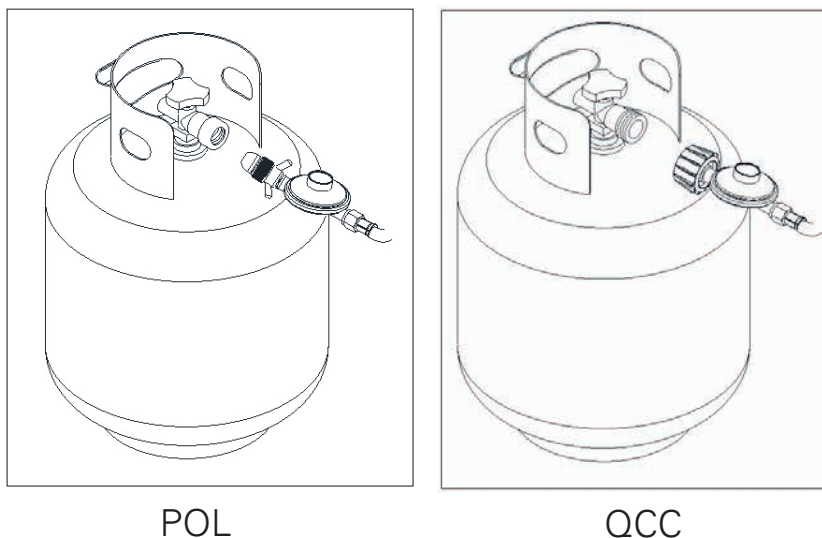

2. Turn the gas on at the cylinder, or make sure gas is available to the BBQ, but do not turn the burners on. This fills the gas lines with gas. Now brush or pour some soapy water onto all connections. If there is a leak, bubbles should appear within about 20 seconds. If you find any leaks, tighten the connection and repeat the leak test. If the leaks persist, contact your place of purchase.

WARNINGS

DO NOT USE NAKED FLAME FOR LOCATING GAS LEAKS

IF A LEAK PERSISTS, CALL AN AUTHORISED PERSON

DO NOT USE THIS BBQ UNLESS ALL CONNECTIONS ARE GASTIGHT

In the case of a problem arising with the hose and regulator please contact your BBQ supplier for a list of approved replacement parts.

LIGHTING PROCEDURE

BEFORE STARTING

- Lighting the BBQ is easy, but must be done with due care.
- Make sure the LPG cylinder is filled.
- Make sure that gas is turned on at the cylinder, or that gas is available to the BBQ.
- Check that the end of each burner tube is properly located over each valve orifice.
- Make sure all gas connections are securely tightened.
- Open the hood or side burner lid.

TYPES OF IGNITION

MANUAL IGNITION (in case of lighting failure from BBQ ignition)

- With the hood or side burner lid open, place a lit match or long stem gas lighter close to the burner you wish to light. Be cautious of the position of your hand and ensure it remains a reasonable distance from the burner. Turn the control to the "High" position. The burner should light. If it fails to light, return the control to the "OFF" position and try again in five minutes.

FLAME THROWER IGNITION OF BBQ BURNERS

- The BBQ burners are equipped with automatic ignition. It works by throwing a flame to the side of the burner to light. Push the knob in and turn anticlockwise to the high position. You should hear and feel a click from the knob. Hold the knob in and observe the flame extend towards the side of the burner. When the burner ignites, release the control knob. If the burner doesn't light on the first attempt, return the knob to the "OFF" position and try several more times. If the burner still does not light, wait a few minutes to allow the gas to disperse before trying again.

SIDE BURNER IGNITION

- The side burner incorporates an electrode next to the side burner. To light the side burner, simply push the side burner knob in and turn anticlockwise to the high position. You should hear and feel a click from the knob. When the burner ignites, release the control knob. If the burner doesn't light on the first attempt, return the knob to the "OFF" position and try several more times. If the burner still does not light, wait a few minutes to allow the gas to disperse before trying again.



USING THE BBQ

CONTROLLING THE FLAMES

The knobs have three basic positions. You can achieve any flame height between low and high by rotating the knob between these positions.

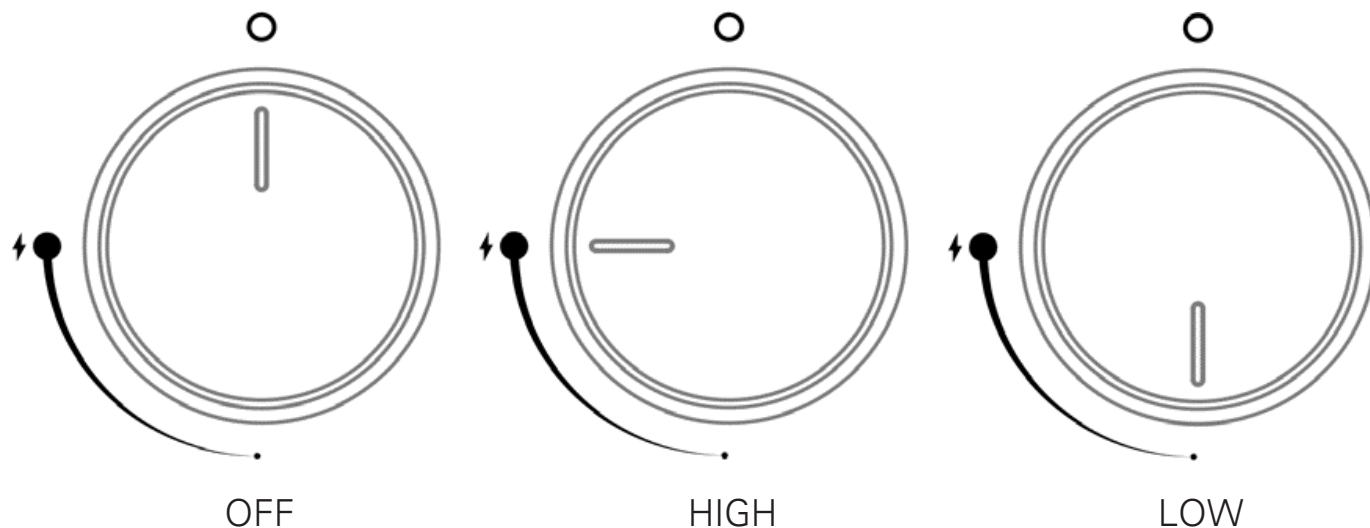

NOTE: 'Light back' is a situation where the flame burns inside the burner, towards the front, recognized by a sharp roaring sound coming from the burner. It is not dangerous unless allowed to persist. If this occurs, simply turn the burner off, wait a few minutes, and then relight.

COOKING FOR THE FIRST TIME

- **IMPORTANT: Please add sand or fat absorption granules to the grease tray before first use.**
- We recommended you wash the cooking surfaces with soap and warm water before use.
- The cooking plates are vitreous enamel coated and they do not require seasoning like most other BBQs.

USING THE SMOKER BOX

The following steps are guide to getting good lasting smoke from the wood chips in your smoker box.

1. With the hood open and the burners off, slide out the smoker box and fill with your favourite wood chips. Ensure the smoker box is not over filled and the lid can close fully before sliding back into the BBQ.
2. Ignite burners 3 and 4 (seen in the below image on either side of the smoker box) and turn to a medium setting. Ensure the hood of the BBQ remains open during this step.

Leave on medium for approximately 10 - 15 minutes or until you see white smoke wafting from the grill plates.

3. When smoke has been achieved, turn off burner 3, turn burner 4 to low and turn on burner 1 to low. At this stage, the lid of the BBQ can now be closed and is ready for smoking your favourite food.

You will receive approximately 20 - 25 minutes of smoke time. This depends on the weather conditions and type of wood chips used.

The smoker box can be refilled at anytime. Be sure to use high temperature gloves as the smoker box will be very hot.

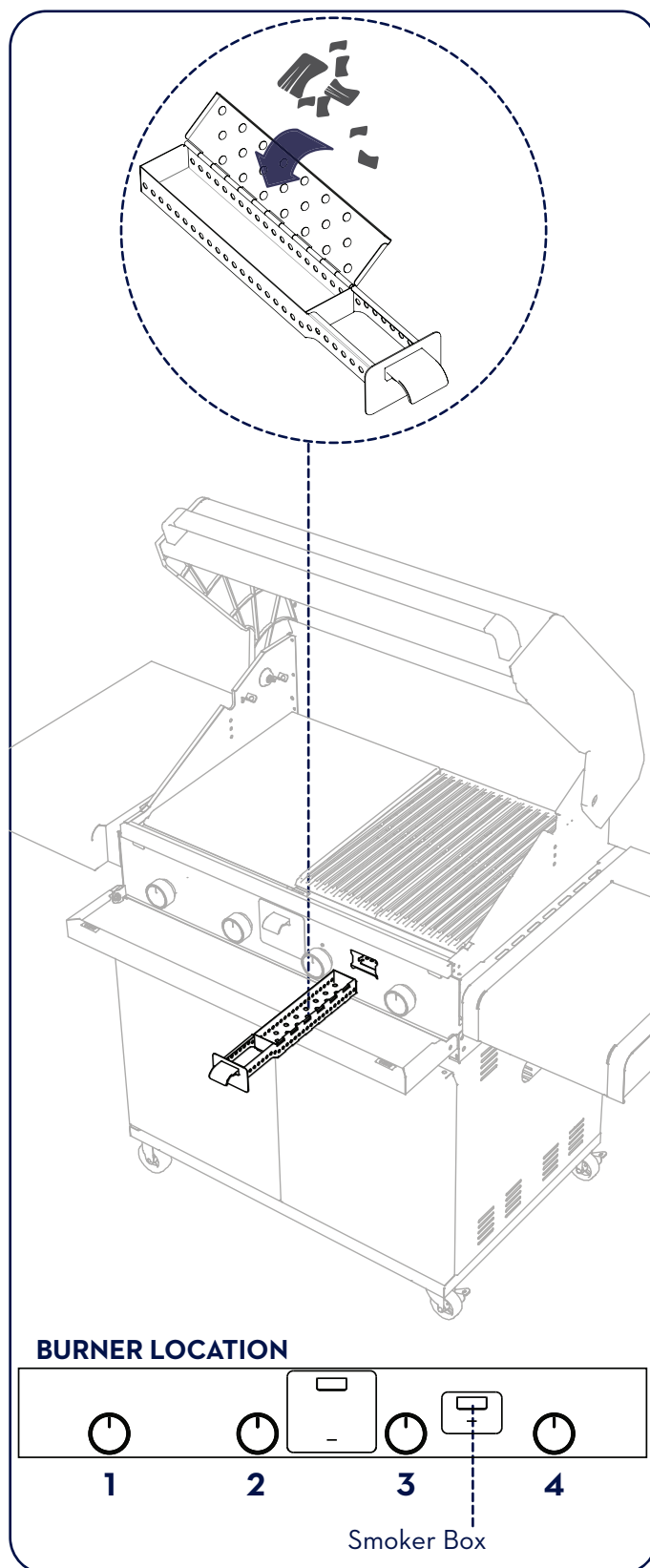

BBQ TIPS

Before cooking, coat the hotplate with oil. This will prevent food from sticking. Open the hood and light the burners to preheat the BBQ.

Avoid continually turning the meat over. When cooking internal juices rise to the surface of the meat and then settle. Each time you turn the meat over, the juices are lost.

Keep the valleys in the cooking plate clear for fat and oils to flow to the grease collection cup at the front of the BBQ. A scraper tool is provided to make this easy. This can be seen below.

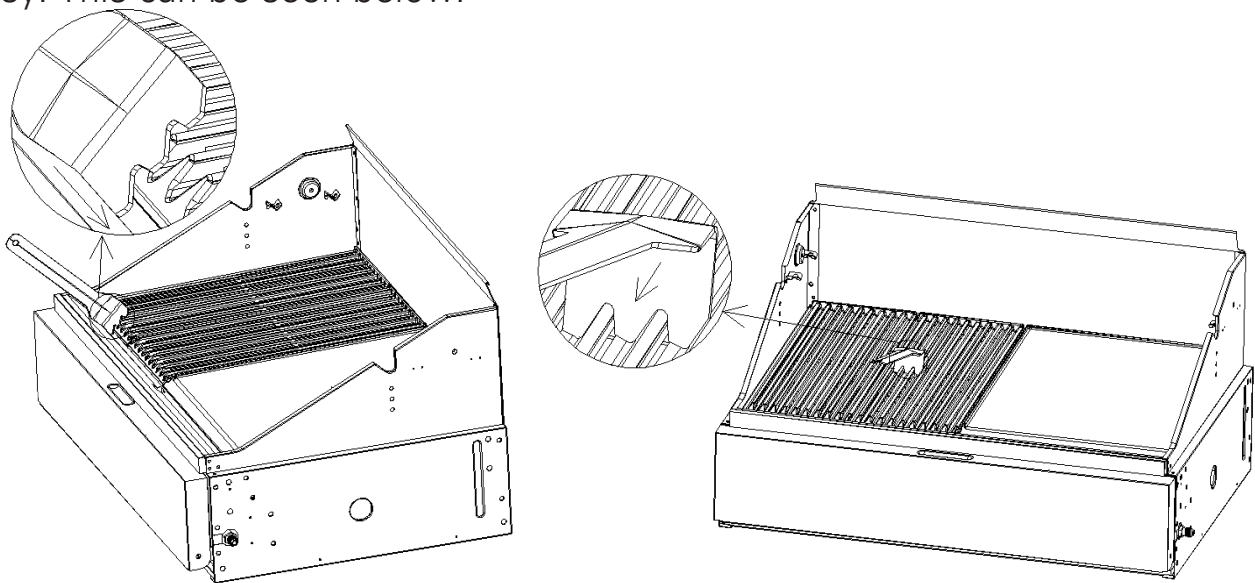

Oil does not flow uphill. If your BBQ is not correctly positioned, oil won't flow forward to the grease collection cup.

Avoid burning or charring food excessively and do not leave cooked food standing for too long before eating.

The minimum size LPG cylinder recommended for this BBQ is 9kg The maximum vessel size on the side burner is diameter 25cm

Check the Grease Cup before use to prevent overflow of grease.

AFTER USE

To turn the BBQ off, it is best to turn off the cylinder first, and allow all the gas remaining in the hose to burn off, this will only take a couple of seconds. Then turn off all burners. While the hotplate is still hot, take a long handled brush and a scraper and remove remaining oil and food scraps. You should use protective gloves to avoid burning yourself. Then re-coat the plate with oil for continued protection.

BBQ MAINTENANCE

PERIODIC CLEANING

- Your BBQ will look better and last longer if you keep it clean.
- You should check the burners periodically for any sort of blockage. To do this, remove and inspect them. If any of the holes are clogged, gently tap the burner onto a hard surface to remove residue. Use a wire brush to unclog the holes.
- Grease can build up on the frame itself. Most of it can be cleaned off with hot water. Use a non-caustic cleanser for more stubborn stains.
- You should empty the fat / drip tray frequently. Never touch the fat / drip tray until the BBQ and fat have cooled down completely.
- **A build up of grease, fat and carbon are flammable and a lack of regular cleaning can result in a fire.** Check the smoker tray for a build up of residue periodically or whenever you clean your BBQ.

ABNORMAL OPERATION

Abnormal operation which may require service can be identified by the following:

- A yellow burner flame
- A thick, black build-up of soot.
- Control valves that seize or are difficult to turn.
- Burners which are difficult to light.

If the BBQ fails to operate correctly, contact an authorised service person for repair.

BBQ STORAGE

- Ensure the BBQ is properly cooled.
- Storage of this gas BBQ indoors is permissible only if the gas cylinder is disconnected and removed from the BBQ.
- Store the BBQ in a cool dry place.
- Always disconnect the gas cylinder and store it in a safe place, never store a gas cylinder on its side.
- Never store a gas cylinder in a building, garage or any other enclosed area.
- If you intend to leave your BBQ outside make sure it is protected from the elements by a heavy-duty cover (not included).
- Keep outdoor cooking gas BBQ area clear and free from combustible materials, petrol and other flammable vapours and liquids.



BURNER MAINTENANCE

To reduce the chance of "FLASH-BACK" the procedure below should be followed at least once a month in late summer or early autumn when spiders are most active or when your BBQ has not been used for a period of time. The procedure is as follows:

1. Turn all burners' valves to the full OFF position.
2. Turn the LPG cylinder valve (clockwise) to the full OFF position.
3. Detach the regulator assembly from the LPG cylinder.
4. Remove the warming rack, cast iron grill, hotplate and drip tray from your grill.
5. Remove all burners from the bottom of the grill by unscrewing the screw at the end of the burner using a phillips head screwdriver.
6. Carefully lift each burner up and away from the gas valve orifice, as seen below.

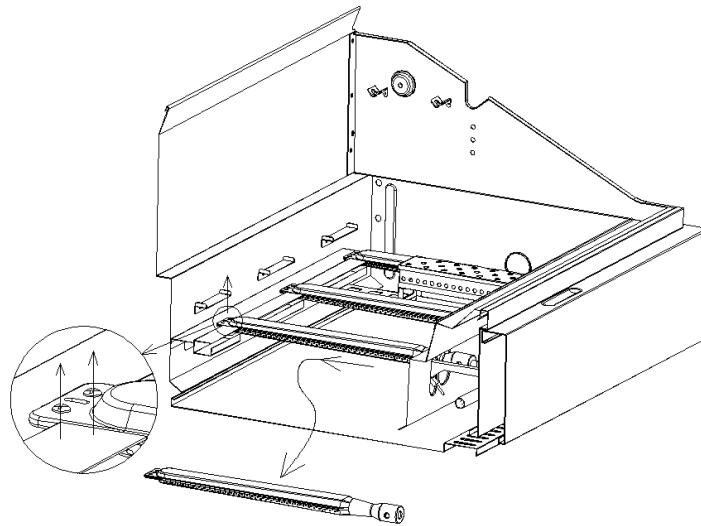

7. To clean the inside of the removed burner, multiple methods can be used, such as:
 - a. Bending a stiff wire (such as a coat hanger) into a hook (seen below)
 - b. Using a bottle brush with a flexible handle
 - c. Using an air hose



8. Use a wire brush to clean the entire outer surface of each burner until free of food residue, and dirt, as well as using a thin object to unclog ports
9. Inspect each burner after installation, check to ensure that the gas valve orifices are correctly placed inside the end of the burner tubes.

GLASS HOOD REPLACEMENT

Always wear gloves during replacement of the hood glass. The following steps outline the procedure to replace the glass hood.

1. Remove the Temperature Gauge.

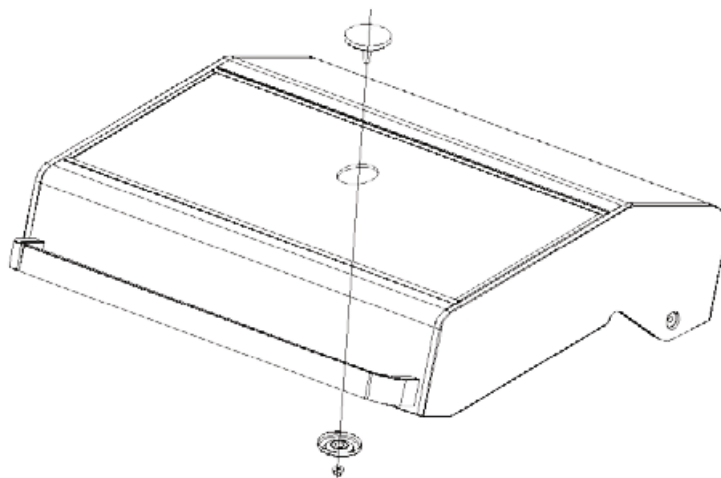

2. Disassemble the four M5 screws on the side of the unit

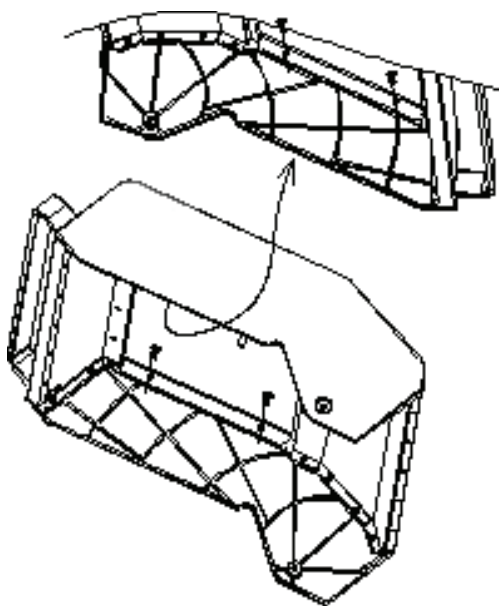

3. Carefully remove the glass.

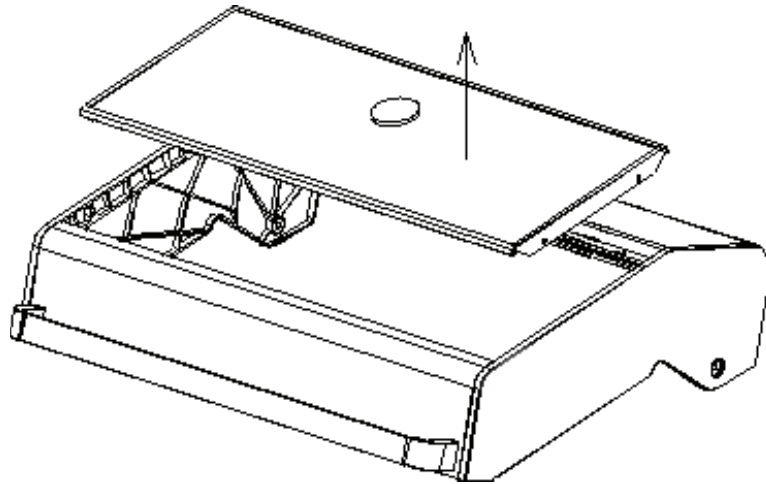

4. According to the arrow directions, remove all the parts from the glass as shown.

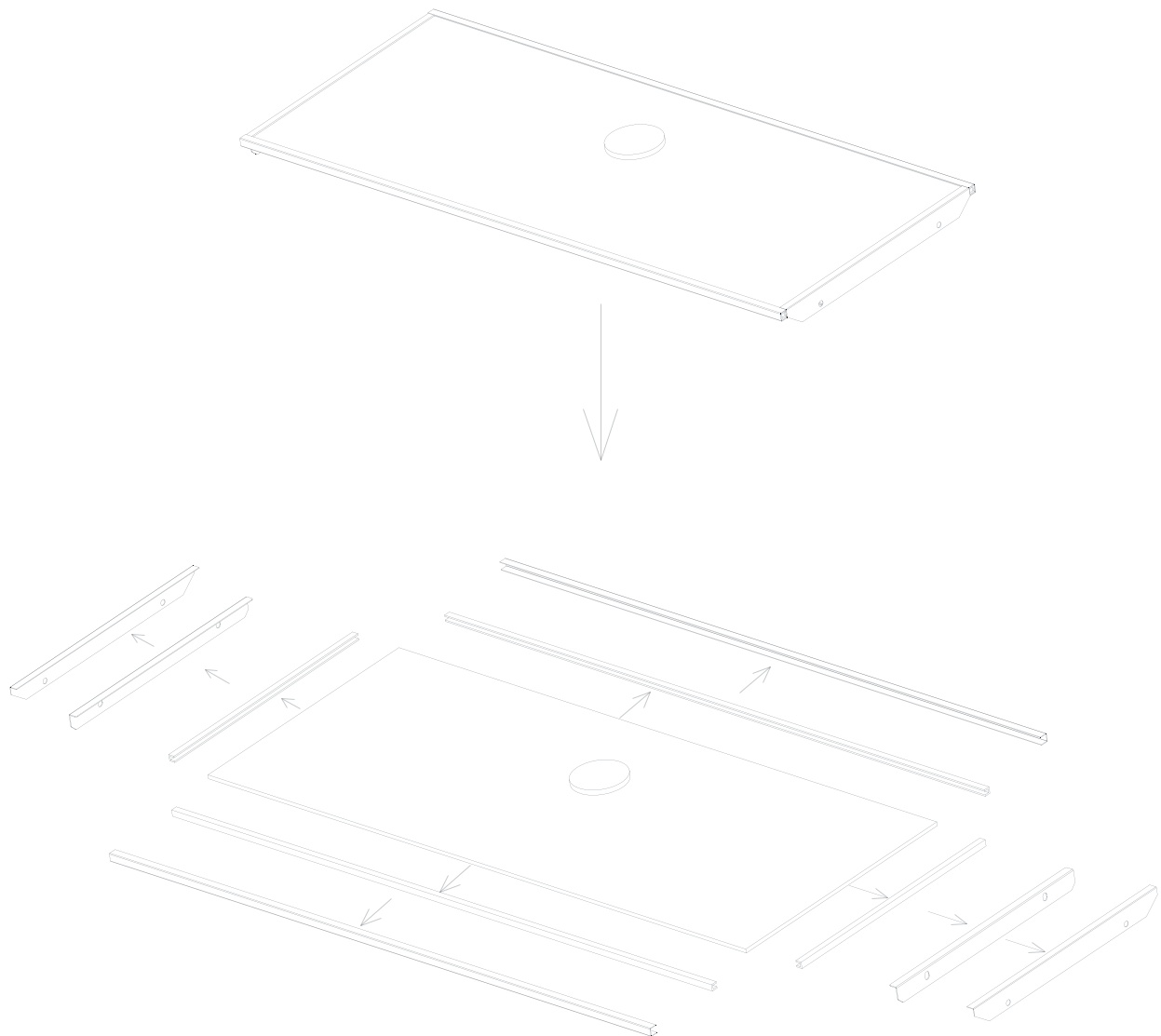

5. According to the arrow directions, assemble all the parts onto the replacement glass as shown.

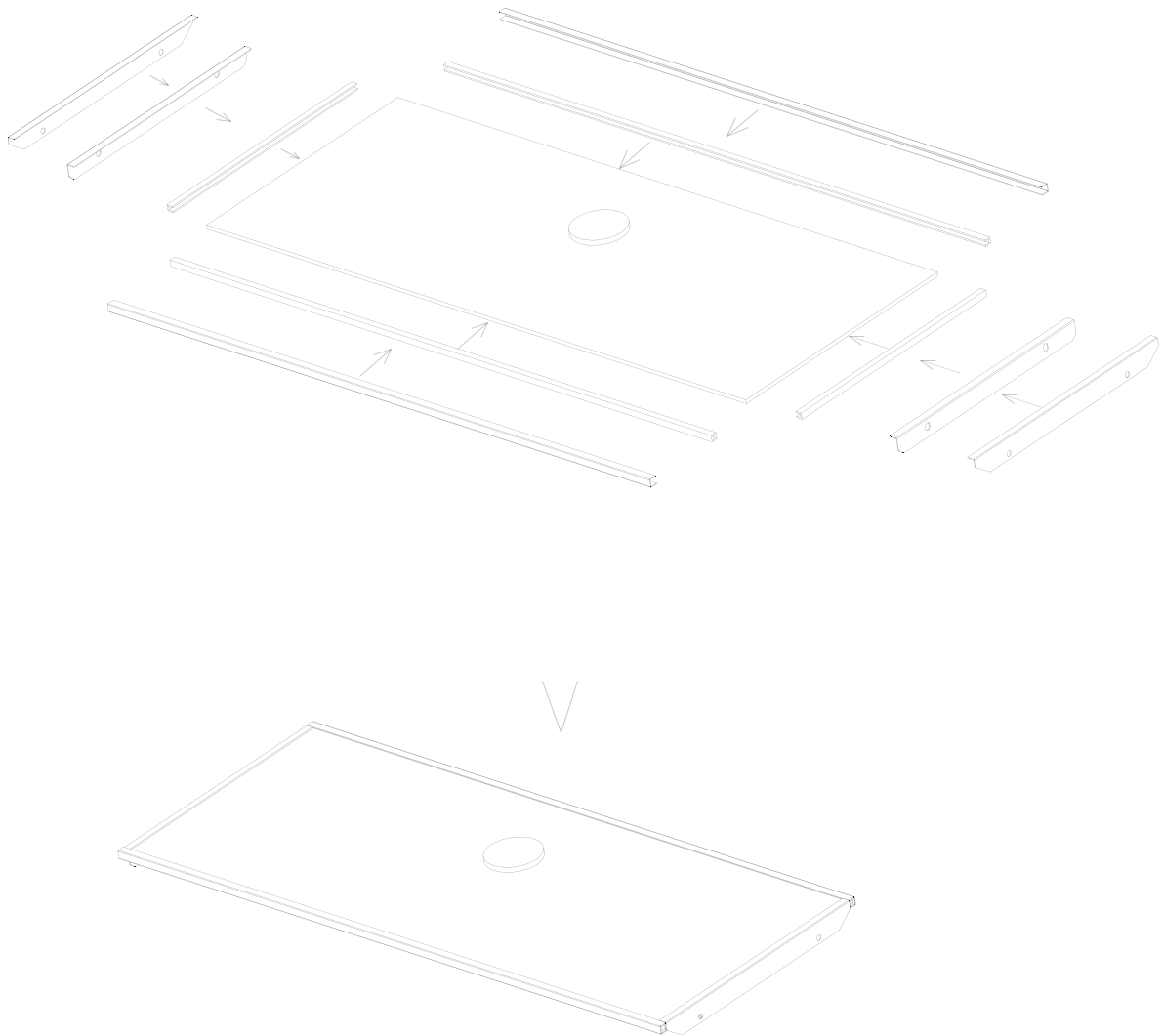

6. Place the new glass assembly back onto the hood.

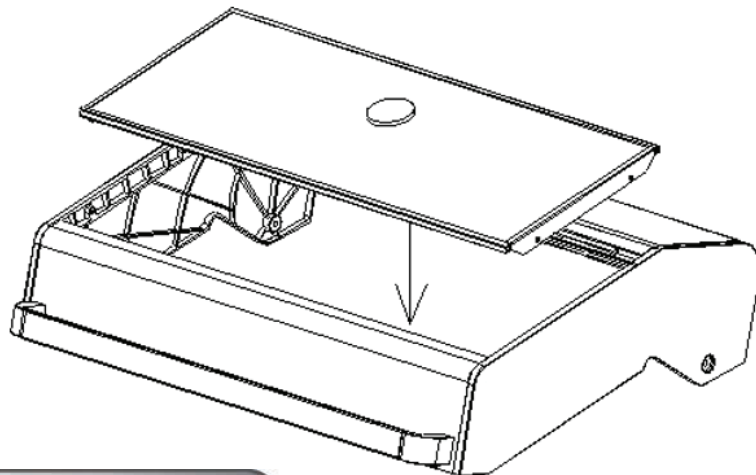

7. Assemble the side panels on the hood by fastening the four M5 screws as shown. Fit the temperature gauge on the glass.

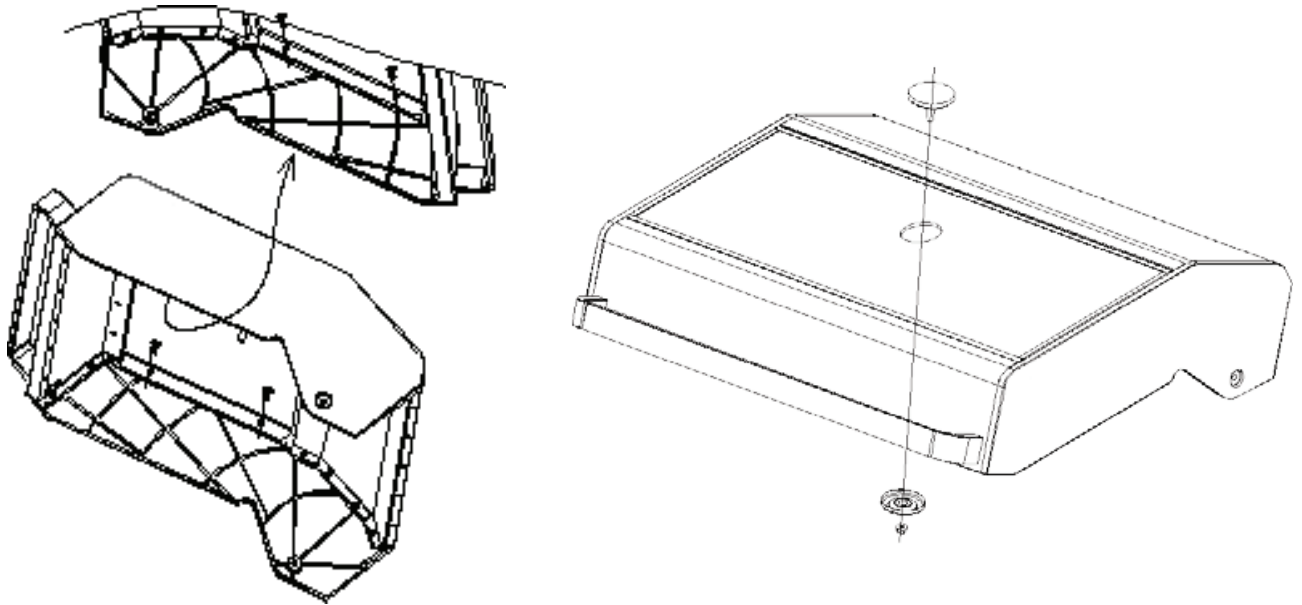

The process is now complete. Check to ensure that the glass is sitting correctly on the hood and that it is not loose.

HANDY BBQ TIPS

- Ensure your BBQ is level before use so excess fat and oil can freely flow to the oil cup in the front of the BBQ.
- If food debris falls into the valleys of the cooking grill and prevents flow to the oil cup, use the supplied Scraper Tool to quickly clear the valleys.
- Preheat the grill before cooking for perfect sear marks every time.
- Always keep a spare LPG cylinder filled and ready to go but never store the spare cylinder near the BBQ.
- Use BBQ wipes to wipe down the shiny black ceramic coated panels inside the BBQ before cooking. The Matte black panels inside the BBQ are Pyrolytic self-cleaning panels and they don't require wiping.
- Always keep the solid plate on the right, directly above the smoker/flavour tray to ensure the smoker/flavor tray is always free of fat and grease residue.

GENERAL CARE AND MAINTENANCE INFO

- **Note:** Remember to turn off and disconnect the gas before any maintenance is carried out.
- If your BBQ uses a flexible hose to connect to the gas cylinder, check the rubber O-ring on the regulator end of the hose assembly at least once a year. If it appears worn or cracked, have it replaced. Only use the hose supplied by the manufacturer.
- We recommend having your BBQ checked by an authorised service agent every 5 years. This is to ensure there are no leaks and that all components are still functioning correctly.
- Keep the outdoor gas BBQ area clear and free from combustible materials, petrol, and other flammable vapours or liquids.
- Make sure there is no obstruction surrounding the BBQ, which may block the flow of combustion and ventilation air.
- To maintain the surface of your hotplate and grill plate, it is recommended to periodically wash cooking surfaces with a mild soap and warm water solution. Afterwards keep the hotplate and grill plate oiled and covered with the hood when not in use. A BBQ cover (not included) is also recommended to cover your BBQ and maintain and protect from all weather conditions.
- Regularly change the sand / fat absorption granules in the drip tray.



SPECIFICATIONS

REGULATOR & HOSE ASSEMBLY: 2.75kPa, POL type regulator and 8mm ID, Class A hose 3/8SAE Female outlet. AGA approved.

Burner Configuration Table - Propane

BURNERS	NOMINAL GAS CONSUMPTION	TEST POINT PRESSURE	INJECTOR SIZE
BBQ	15 MJ/h (per burner)	2.75 kPa	1.1mm
Side	15 MJ/h	2.75 kPa	1.1mm

Burner Configuration Table - Universal LPG

BURNERS	NOMINAL GAS CONSUMPTION	TEST POINT PRESSURE	INJECTOR SIZE
BBQ	15 MJ/h (per burner)	2.75 kPa	1.07mm
Side	15 MJ/h	2.75 kPa	1.1mm

Burner Configuration Table - Natural Gas

BURNERS	NOMINAL GAS CONSUMPTION	TEST POINT PRESSURE	INJECTOR SIZE
BBQ	15 MJ/h (per burner)	1.00 kPa	1.8mm
Side	15 MJ/h	1.00 kPa	1.8mm

Tap Specifications

WATERMARK LICENSE NUMBER	WM-022545
WELS REGISTRATION NUMBER	T30270
LICENSE NUMBER	1547
NOMINAL FLOW RATE	4.47 LPM
WATER EFFICIENCY STAR RATING	6

CONNECTING TO NATURAL GAS

This BBQ has been configured for use with LPG from a gas cylinder. If you want to connect this BBQ to a permanent Natural Gas supply, the following steps must be undertaken.

1. Contact a licensed plumber or gas fitter and arrange a quote to convert this BBQ to Natural Gas, install any pipework necessary to bring a natural gas supply to the installation area and commission the BBQ. All works must be made by a licensed plumber or gas fitter in accordance with AS5601.1.
2. Contact Pacific Gas & Heating Pty Ltd directly on Tel: 1300 793978 or email info@pacificgas.com.au to order the gas conversion kit specific to your model and supply the name and license number of your chosen gas fitter.
3. Obtain a certificate of compliance from your licensed gas fitter after installation is complete.

Natural Gas Conversion Procedure

Gas conversion must be conducted by a licensed plumber or gas fitter only.

1. Remove the main BBQ Burners.
2. Remove LPG injectors from all the main burner valves and replace with Natural Gas Injectors. The natural gas injector size is 1.8mm on the main burners.
3. Install BBQ Burners.
4. Set the side burner aeration shutter to 4mm open.
5. Remove the side burner valve and replace it with the side burner valve for Natural Gas. Replace the side burner injector with the 1.8mm side burner injector for Natural Gas.
6. Remove 2.75kPa LPG hose and regulator assembly and replace with the stainless steel braided hose and adapter fitting to ½" BSP, and the ½" BSP Natural gas regulator with 1.0kPa operating pressure.



- 7.** Apply the Natural Gas type label over the Propane label.
- 8.** Permanently fix the BBQ to the floor in the installed position using the supplied fixing bracket, which slots into the LPG Cylinder hole on freestanding BBQs. This ensures the BBQ cannot move and strain the gas supply lines.
- 9.** Leak test all connections.
- 10.** Before leaving, test the operation of all burners on high and low to complete the commissioning process. This involves removal of the knobs to access the screw adjustable low flame by pass to set a stable low flame.
- 11.** Instruct the consumer on correct use of the BBQ and the location of the gas supply isolation valve which shall be closed after each use.
- 12.** If the BBQ is supplied with a duplicate data label, apply this label in the immediate vicinity of the BBQ in an easily accessible area.

PRODUCT WARRANTY

Thank you for purchasing one of our quality MATADOR products. Your MATADOR product is covered against defects for a period of 5 years for parts and labour, repair or replacement. This warranty excludes surface rust and damage caused by abuse or neglect.

This warranty in **Australia** is given by Pacific Gas & Heating Pty Ltd,
Tel: 1300 793978
Email: info@pacificgas.com.au

The warranty in **New Zealand** is given by Bunnings NZ Ltd, PO BOX 14436, Panmure, Auckland, 1741.
Tel: 09-9780000 Fax: 09-9782222
Email: marketing@bunnings.co.nz

Any claim under this warranty must be made within 5 years of the date of purchase of the product. Proof of purchase must be presented.

Goods presented for repair may be replaced by refurbished goods of the same type rather than being repaired. Refurbished parts may be used to repair the goods.

FOR AUSTRALIAN CUSTOMERS

To make a claim under the warranty please contact the store where the product was purchased or contact Pacific Gas & Heating Pty Ltd directly.

CONDITIONS OF THE WARRANTY

The warranty covers domestic use only and does not apply to commercial applications. You may submit details and proof to our store for consideration.

The warranty covers manufacture defects in materials, workmanship and finish under normal use. This warranty is provided in addition to other rights and remedies you

may have under law: our goods come with guarantees which cannot be excluded under the Australian Consumer Law. You are entitled to replacement or refund for a major failure and to compensation for other reasonably foreseeable loss or damage. You are also entitled to have the goods repaired or replaced if the goods fail to be acceptable quality and the failure does not amount to a major failure.

FOR NEW ZEALAND CUSTOMERS

To make a claim under the warranty, take the product (with proof of purchase) to any Bunnings store (See www.bunnings.co.nz for store locations). This warranty is provided in addition to other rights and remedies you may have under law: our goods come with guarantees which cannot be excluded under the Consumer Guarantees Act 1993(NZ). You are entitled to replacement or refund for a major failure and to compensation for other reasonably foreseeable loss or damage. You are also entitled to have the goods repaired or replaced if the goods fail to be of acceptable quality and the failure does not amount to a major failure.

Goods presented for repair may be replaced by refurbished goods of the same type rather than being repaired. Refurbished parts may be used to repair the goods.

The warranty excludes damage resulting from product misuse or product neglect.

The warranty covers domestic use only and does not apply to commercial applications.



PRODUCT WARRANTY

Please thoroughly read conditions of warranty.

- The appliance must be operated and maintained in accordance with the instructions supplied in the operating manual.
- Any repair does not extend the warranty period.
- Any parts other than original Matador parts will void this warranty.

INSTALLATION CONDITIONS

All installations must conform to the applicable Electrical and Building standards as laid down by the local codes or state or region.

WHAT IS NOT COVERED IN THE WARRANTY

- Removal or re-installation costs. This warranty does not cover costs for transit nor in home service.
- Lack of maintenance, abuse, neglect, misuse, accidental or improper installation of this appliance.
- Scratches, dents, corrosion or discolouration caused by heat, abrasive chemical cleaners or chipping.
- Corrosion or damage caused by exposure to the elements such as insects, weather or hail.
- Cleaning and wear and tear; service calls of this nature are chargeable. Commercial use of the product.
- Unauthorised repairs or modifications during the warranty period.
- Consumable items, example – heating elements.

RECORD THE FOLLOWING INFORMATION

Attach a copy of the purchase receipt here:

Date of purchase

Purchase from

Location

Model no. & name

Date of manufacture

Receipt number

FOR TECHNICAL ASSISTANCE

FOR AUSTRALIAN CUSTOMERS

If you experience any technical issues with your MATADOR product, in the first instance review the instruction manual or call the warranty service agent below.

FOR NEW ZEALAND CUSTOMERS

If you experience any technical issues with your MATADOR product, in the first instance review the instruction manual or call your local Bunnings Warehouse.

WARRANTY CLAIMS

FOR AUSTRALIAN CUSTOMERS

Please contact Pacific Gas & Heating Pty Ltd,

Tel: 1300 793978.

Email: info@pacificgas.com.au

FOR NEW ZEALAND CUSTOMERS

Please contact the store where the product was purchased.



Visit www.matadorbbqs.com.au

For technical and warranty support call
1300 793 978 (AUS)
09-9780 000 (NZ)

Your purchase receipt will be required for warranty claims.
For spare parts contact Pacific Gas & Heating Pty Ltd.