

---

**S P E C F I L E**

---

**Product Number :** PT-DW11K

**Product Name :** 3-Chip DLP™ Projector

Specifications

Main unit

Power supply		120 V AC, 9.1 A, 50/60 Hz 220–240 V AC, 4.8 A, 50/60 Hz
Power consumption	120 V AC, 50/60 Hz	980 W (1,010 VA) (0.2 W with standby mode set to eco.*1 6 W with standby mode set to normal. Both with fan stopped.)
	220–240 V AC, 50/60 Hz	950 W (980 VA) (0.3 W with standby mode set to eco.*1 9 W with standby mode set to normal. Both with fan stopped.)
DLP™ chip	Panel size	21.6 mm (0.85 inches) diagonal (16:9 aspect ratio)
	Display method	DLP™ chip × 3 (R, G, B), DLP™ projection system
	Pixels	1,049,088 (1,366 × 768) × 3, total of 3,147,264 pixels
Lens		Optional powered zoom/focus lenses
Lamp		380 W UHM lamps (× 2) (dual lamp, high mode)
Screen size		1.78–25.4 m (70–1,000 inches) (1.78–15.24 m (70–600 inches) with the ET-D75LE8), 16:10 aspect ratio
Brightness*2		11,000 lumens (dual lamp, high mode)
Center-to-corner uniformity*2		90%
Contrast*2		10,000:1 (full on/full off, in dynamic iris 3 mode)
Resolution		1,366 × 768 pixels (Input signals that exceed this resolution will be converted to 1,366 × 768 pixels.)
Scanning frequency	HDMI/DVI-D/RGB	Horizontal: 15 kHz–100 kHz, vertical: 24 Hz – 120 Hz, dot clock: 25–162 MHz or lower (HDMI/DVI: 25 MHz – 162 MHz)
	YPbPr (YCbCr)	525i (480i): fH 15.75 kHz; fV 60 Hz, 625i (576i): fH 15.63 kHz; fV 50 Hz, 525p (480p): fH 31.50 kHz; fV 60 Hz, 625p (576p): fH 31.25 kHz; fV 50 Hz, 750 (720)/60p: fH 45.00 kHz; fV 60 Hz, 750 (720)/50p: fH 37.50 kHz; fV 50 Hz, 1125 (1035)/60i: fH 33.75 kHz; fV 60 Hz, 1125 (1080)/60i: fH 33.75 kHz; fV 60 Hz, 1125 (1080)/50i: fH 28.13 kHz; fV 50 Hz, 1125 (1080)/25p: fH 28.13 kHz; fV 25 Hz, 1125 (1080)/24p: fH 27.00 kHz; fV 24 Hz, 1125 (1080)/24sF: fH 27.00 kHz; fV 48 Hz, 1125 (1080)/30p: fH 33.75 kHz; fV 30 Hz, 1125 (1080)/60p: fH 67.50 kHz; fV 60 Hz, 1125 (1080)/50p: fH 56.25 kHz; fV 50 Hz
	Video/S-Video	fH: 15.75 kHz, fV: 60 Hz [NTSC/NTSC4.43/PAL-M/PAL60] fH: 15.63 kHz, fV: 50 Hz [PAL/PAL-N/SECAM]
Optical axis shift	Vertical	±70% (±60% with the ET-D75LE6) from center of screen, powered
	Horizontal	±30% (±20% with the ET-D75LE6) from center of screen, powered
		<b>NOTE: Optical axis shift function cannot be operated when used with the ET-D75LE50.</b>
Keystone correction range		Vertical ±40° (vertical ±22° with the ET-D75LE5/LE50, vertical ±28° with the ET-D75LE6)
Installation		Ceiling/floor, front/rear
Terminals	HDMI IN	HDMI 19-pin × 1, Deep Color, compatible with HDCP, 525i(480i)*3, 625i(576i)*3, 525p(480p), 625p(576p), 750(720)/60p, 750(720)/50p, 1125(1080)/60i, 1125(1080)/50i, 1125(1080)/25p, 1125(1080)/24p, 1125(1080)/24sF, 1125(1080)/30p, 1125(1080)/60p, 1125(1080)/50p VGA (640 × 480)–WUXGA*4 (1,920 × 1,200), dot clock: 25 MHz–162 MHz <b>NOTE: Compatible with non-interlaced signals only.</b>

DVI-D IN	DVI-D 24-pin × 1, DVI 1.0 compliant, HDCP compatible, for single link only 525i(480i)*3, 625i(576i)*3, 525p(480p), 625p(576p), 750(720)/60p, 750(720)50p, 1125(1080)/60i, 1125(1080)/50i, 1125(1080)/25p, 1125(1080)/24p, 1125(1080)/24sF, 1125(1080)/30p, 1125(1080)/60p, 1125(1080)/50p VGA (640 × 480)–WUXGA*4 (1,920 × 1,200), dot clock: 25 MHz–162 MHz <b>NOTE: Compatible with non-interlaced signals only.</b>
RGB 1 IN R, G, B	BNC × 5 R: 0.7 Vp-p, 75 ohms, G: 0.7 Vp-p (G: 1.0 Vp-p for sync on G), 75 ohms, B: 0.7 Vp-p, 75 ohms HD, VD/SYNC: TTL, high impedance, positive/negative automatic <b>NOTE: SYNC/HD and VD terminals do not accept tri-level sync signals.</b>
Y, PB, PR (Y, CB, CR) S-Video signal	Y: 1.0 Vp-p (including sync signal), PB/PR (CB/CR): 0.7 Vp-p, 75 ohms Y: 1.0 Vp-p, C: 0.286 Vp-p, 75 ohms
RGB 2 IN R, G, B	D-sub HD 15-pin (female) × 1 R: 0.7 Vp-p, 75 ohms, G: 0.7 Vp-p (G: 1.0 Vp-p for sync on G), 75 ohms, B: 0.7 Vp-p, 75 ohms HD, VD/SYNC: TTL, high impedance, positive/negative automatic <b>NOTE: SYNC/HD and VD terminals do not accept tri-level sync signals.</b>
Y, PB, PR (Y, CB, CR) VIDEO IN	Y: 1.0 Vp-p (including sync signal), PB/PR (CB/CR): 0.7 Vp-p, 75 ohms BNC × 1, 1.0 Vp-p, 75 ohms
3D SYNC 1 IN/OUT	BNC × 1, 1.0 Vp-p, 75 ohms Input: TTL, high impedance. Output: TTL, max. 10 mA
3D SYNC 2 OUT	BNC × 1, 1.0 Vp-p, 75 ohms, TTL, max. 10 mA
SERIAL IN	D-sub 9-pin (female) × 1 for external control (RS-232C compliant)
SERIAL OUT	D-sub 9-pin (male) × 1 for link control (RS-232C compliant)
REMOTE 1 IN	M3 jack × 1 for wired remote control
REMOTE 1 OUT	M3 jack × 1 for link control
REMOTE 2 IN	D-sub 9-pin × 1 for external control (parallel)
LAN	RJ-45 × 1 for network connection, 100Base-TX/10Base-T, compliant with PLink™ (class 1)
Power cord length	3.0 m (9 ft 10 in)
Cabinet materials	Molded plastic
Dimensions (W × H × D):	530 × 200*5 × 548.5 mm (20-7/8 × 7-7/8*5 × 21-19/32 inches) (without lens)
Weight*6	24 kg (52.9 lbs) (without lens)
Operation noise*2	45 dB (high mode), 43 dB (middle mode), 37 dB (eco mode)
Operating temperature	0°–45°C (32°–113°F)*7
Operating humidity	10%–80% (no condensation)
<b>Remote control unit</b>	
Power supply	3 V DC (AA/R6 type battery × 2)
Operation range*8	Approx. 30 m (98 ft 5 in) when operated from directly in front of the signal receptor
Dimensions (W × H × D)	51 × 176 × 28 mm (2 × 6-15/16 × 1-3/32 inches)
Weight	Approx. 134 g (4.7 oz) (including batteries)
<b>Supplied accessories</b>	
	Power cord (×1) (x2 for PT-DW11KE)
	Wireless/wired remote control unit (× 1)
	Batteries for remote control (AA/R6 type × 2)
	Lens drop-prevention screw (× 1)
	Software CD-ROM (Logo Transfer Software, Multi Projector Monitoring & Control Software) (× 1)

**Optional accessories**

Zoom lens (1.0–1.2:1)	ET-D75LE6
Zoom lens (1.4–1.9:1)	ET-D75LE10
Zoom lens (1.8–2.7:1)	ET-D75LE20
Zoom lens (2.7–5.2:1)	ET-D75LE30
Zoom lens (5.1–8.2:1)	ET-D75LE40
Zoom lens (8.2–15.4:1)	ET-D75LE8
Fixed-focus lens (0.8:1)	ET-D75LE50
Lens motor cover	ET-D75MC1
Ceiling mount bracket* <sup>9</sup>	ET-PKD120H (for high ceilings) ET-PKD120S (for low ceilings)
Attachment for ceiling mount bracket	ET-PAD310
Frame	ET-PFD310
Smoke cut filter	ET-SFD320
Replacement smoke cut filter	ET-SFR320
Replacement lamp unit	ET-LAD310A (one bulb) ET-LAD310AW (a set of two bulbs)
Replacement lamp unit for portrait mode	ET-LAD320P (one bulb) ET-LAD320PW (a set of two bulbs)
Replacement filter unit	ET-EMF320

Weights and dimensions shown are approximate. Specifications and appearance are subject to change without notice.

- \*1 When the standby mode is set to eco, network functions such as power on over the LAN network will not operate, and the serial output terminal cannot be used. Also, only certain commands can be received for external control using the serial terminal.
- \*2 Measurement, measuring conditions, and method of notation all comply with ISO 21118 international standards.
- \*3 Only compatible with dot clock frequency of 27 MHz (pixel repetition signal)
- \*4 WUXGA resolution is supported only when the signals are compliant with VESA CVT-RB (Coordinated Video Timing-Reduced Blanking).
- \*5 With legs at shortest position.
- \*6 Average value (excluding the optional lens). May differ depending on models.
- \*7 The operating temperature range is 0 °C to 40 °C (32 °F to 104 °F) when the FAN CONTROL is set to HIGH ALTITUDE MODE (for altitudes from 1,400 m to 2,700 m (4,593 ft to 8,858 ft) above sea level). When the projector is used with the ET-SFD320 Smoke Cut Filter, the operating temperature range is 0 °C to 35 °C (32 °F to 95 °F), and the projector cannot be used in places at high altitude. The operating temperature range is 0 °C to 40 °C (32 °F to 104 °F) when the ET-LAD320P/LAD320PW lamp is mounted and the projector is used in portrait configuration. The operating temperature range is 0 °C to 35 °C (32 °F to 95 °F) when the FAN CONTROL is set to HIGH ALTITUDE MODE (for altitudes from 1,400 m to 2,700 m (4,593 ft to 8,858 ft) above sea level). When the projector is used with the ET-SFD320 Smoke Cut Filter, the operating temperature range is 0 °C to 30 °C (32 °F to 86 °F).
- \*8 Operation range differs depending on environments.
- \*9 Either the ET-PKD310H ceiling mount bracket for high ceilings or the ET-PKD310S ceiling mount bracket for low ceilings can be used.

Dimensions

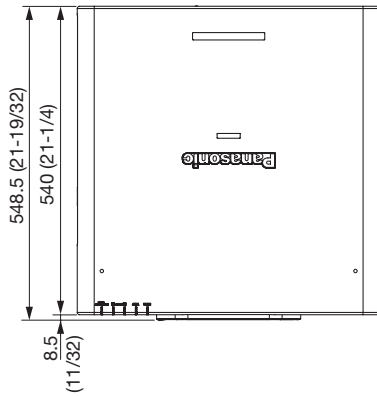

unit : mm (inch)

NOTE: This illustration is not drawn to scale.

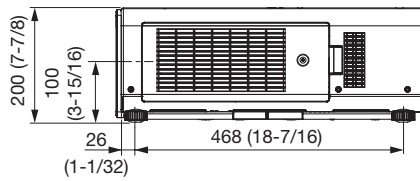
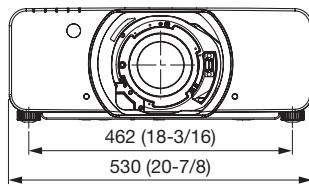

Terminals

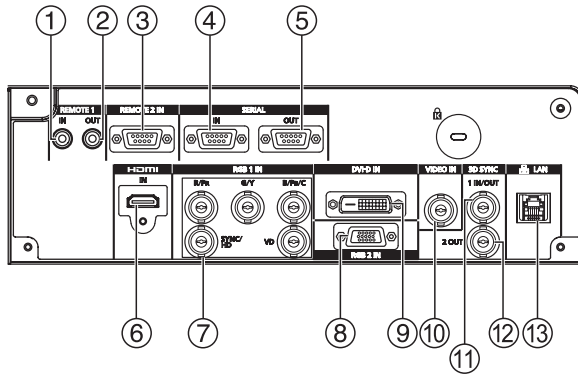

- 1 Remote 1 input
- 2 Remote 1 output
- 3 Remote 2 input
- 4 Serial input
- 5 Serial output
- 6 HDMI input
- 7 RGB 1 input
- 8 RGB 2 Input
- 9 DVI-D input
- 10 Video input
- 11 3D sync 1 input/output
- 12 3D sync 2 output
- 13 LAN connector

Standard setting-up position

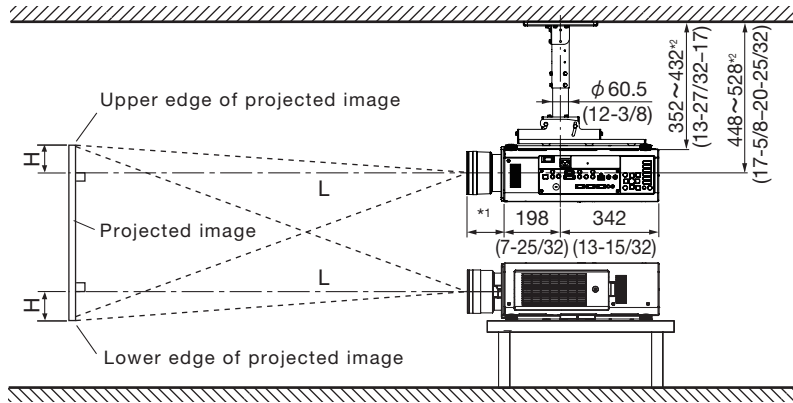

- \*1 When the lens protrudes to the maximum.
- 212 mm (8-11/32) with the ET-D75LE6
  - 125 mm (4-29/32) with the ET-D75LE10
  - 121 mm (4-3/4) with the ET-D75LE20
  - 121 mm (4-3/4) with the ET-D75LE30
  - 124 mm (4-7/8) with the ET-D75LE40
  - 254 mm (10) with the ET-D75LE8
  - 203 mm (8) with the ET-D75LE50

\*2 Adjustable in 40 mm (1-9/16) steps.

unit : mm (inch)

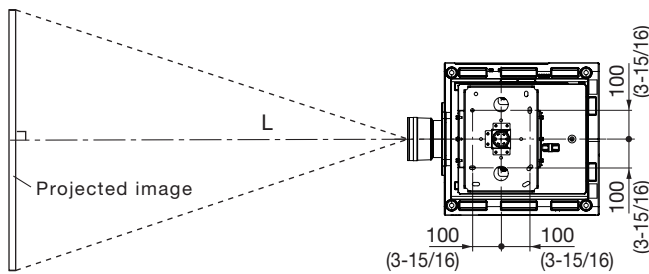

**NOTE:**  
 Illustrations show the projector installed using optional ceiling mount bracket ET-PKD120H, optional bracket assembly ET-PKD310 and an optional lens.

**Caution:**

- All construction work should be done by a qualified technician.
- When mounting to the ceiling, use the special mounting bracket. Furthermore, in order to prevent it from falling down from the ceiling, use the supplied wire on the mounting bracket.

**Projection distance for 16:9 aspect ratio screen**

(ET-D75LE6/D75LE10/D75LE20/D75LE30/D75LE40/D75LE8/D75LE50)

Unit: meters

Screen size (diagonal)	Distance to screen (L)												Height from the edge of screen to center of lens (H)					
	Zoom										Fixed-focus		Zoom lenses		Fixed-focus lens			
	ET-D75LE6 Zoom lens		ET-D75LE10 Zoom lens		ET-D75LE20 Zoom lens		ET-D75LE30 Zoom lens		ET-D75LE40 Zoom lens		ET-D75LE8 Zoom lens		ET-D75LE50 Fixed-focus lens	Except ET-D75LE6				
[m] / [in]	min.	max.	min.	max.	min.	max.	min.	max.	min.	max.	min.	max.						
1.78 / 70	1.56	1.87	2.18	2.82	2.82	4.10	4.07	7.94	7.86	12.62	12.43	23.65	1.16	-0.17	-1.05	-0.09	-0.96	0.44
2.03 / 80	1.79	2.14	2.51	3.24	3.23	4.70	4.67	9.10	9.01	14.45	14.26	27.08	1.34	-0.20	-1.20	-0.10	-1.10	0.50
2.29 / 90	2.02	2.42	2.83	3.66	3.65	5.31	5.27	10.26	10.15	16.27	16.09	30.51	1.51	-0.22	-1.35	-0.11	-1.23	0.56
2.54 / 100	2.25	2.70	3.16	4.08	4.06	5.91	5.87	11.42	11.30	18.10	17.92	33.94	1.69	-0.25	-1.49	-0.13	-1.37	0.62
3.05 / 120	2.72	3.25	3.80	4.92	4.89	7.11	7.07	13.75	13.59	21.75	21.59	40.80	2.04	-0.30	-1.79	-0.15	-1.64	0.75
3.81 / 150	3.41	4.08	4.78	6.18	6.14	8.92	8.86	17.23	17.02	27.23	27.08	51.10	2.57	-0.37	-2.24	-0.19	-2.06	0.93
5.08 / 200	4.56	5.47	6.40	8.27	8.21	11.93	11.85	23.03	22.75	36.36	36.23	68.25	3.45	-0.50	-2.99	-0.25	-2.74	1.25
6.35 / 250	5.72	6.85	8.02	10.36	10.28	14.95	14.84	28.83	28.48	45.49	45.39	85.40	4.33	-0.62	-3.74	-0.31	-3.42	1.56
7.62 / 300	6.87	8.24	9.64	12.46	12.36	17.96	17.83	34.63	34.20	54.62	54.54	102.55	5.21	-0.75	-4.48	-0.37	-4.11	1.87
10.16 / 400	9.18	11.01	12.88	16.65	16.50	23.98	23.81	46.23	45.66	72.88	72.85	136.85	6.97	-1.00	-5.98	-0.50	-5.48	2.49
12.70 / 500	11.49	13.78	16.12	20.84	20.65	30.01	29.80	57.83	57.11	91.14	91.16	171.16	8.72	-1.25	-7.47	-0.62	-6.85	3.11
15.24 / 600	13.80	16.55	19.36	25.02	24.80	36.03	35.78	69.43	68.56	109.40	109.47	205.46	10.48	-1.49	-8.97	-0.75	-8.22	3.74
17.78 / 700	16.11	19.32	22.60	29.21	28.94	42.06	41.76	81.03	80.02	127.66	127.78	-	12.24	-1.74	-10.46	-0.87	-9.59	4.36
20.32 / 800	18.42	22.09	25.84	33.40	33.09	48.08	47.74	92.63	91.47	145.92	146.09	-	14.00	-1.99	-11.96	-1.00	-10.96	4.98
22.86 / 900	20.73	24.86	29.08	37.59	37.23	54.11	53.72	104.23	102.92	164.18	164.40	-	15.76	-2.24	-13.45	-1.12	-12.33	5.60
25.40 / 1000	23.04	27.63	32.32	41.78	41.38	60.13	59.71	115.83	114.38	182.42	182.70	-	17.52	-2.49	-14.94	-1.25	-13.70	6.23

Unit: feet

Screen size (diagonal)	Distance to screen (L)												Height from the edge of screen to center of lens (H)					
	Zoom										Fixed-focus		Zoom lenses		Fixed-focus lens			
	ET-D75LE6 Zoom lens		ET-D75LE10 Zoom lens		ET-D75LE20 Zoom lens		ET-D75LE30 Zoom lens		ET-D75LE40 Zoom lens		ET-D75LE8 Zoom lens		ET-D75LE50 Fixed-focus lens	Except ET-D75LE6				
[m] / [in]	min.	max.	min.	max.	min.	max.	min.	max.	min.	max.	min.	max.						
1.78 / 70	5.1	6.1	7.2	9.3	9.2	13.5	13.4	26.1	25.8	41.4	40.8	77.6	3.8	-0.6	-3.4	-0.3	-3.1	1.4
2.03 / 80	5.9	7.0	8.2	10.6	10.6	15.4	15.3	29.9	29.5	47.4	46.8	88.9	4.4	-0.7	-3.9	-0.3	-3.6	1.6
2.29 / 90	6.6	7.9	9.3	12.0	12.0	17.4	17.3	33.7	33.3	53.4	52.8	100.1	5.0	-0.7	-4.4	-0.4	-4.0	1.8
2.54 / 100	7.4	8.8	10.4	13.4	13.3	19.4	19.3	37.5	37.1	59.4	58.8	111.4	5.5	-0.8	-4.9	-0.4	-4.5	2.0
3.05 / 120	8.9	10.7	12.5	16.1	16.0	23.3	23.2	45.1	44.6	71.4	70.8	133.9	6.7	-1.0	-5.9	-0.5	-5.4	2.5
3.81 / 150	11.2	13.4	15.7	20.3	20.1	29.3	29.1	56.5	55.8	89.3	88.8	167.6	8.4	-1.2	-7.4	-0.6	-6.7	3.1
5.08 / 200	15.0	17.9	21.0	27.1	26.9	39.2	38.9	75.5	74.6	119.3	118.9	223.9	11.3	-1.6	-9.8	-0.8	-9.0	4.1
6.35 / 250	18.8	22.5	26.3	34.0	33.7	49.0	48.7	94.6	93.4	149.2	148.9	280.2	14.2	-2.0	-12.3	-1.0	-11.2	5.1
7.62 / 300	22.5	27.0	31.6	40.9	40.5	58.9	58.5	113.6	112.2	179.2	178.9	336.4	17.1	-2.5	-14.7	-1.2	-13.5	6.1
10.16 / 400	30.1	36.1	42.2	54.6	54.1	78.7	78.1	151.7	149.8	239.1	239.0	449.0	22.9	-3.3	-19.6	-1.6	-18.0	8.2
12.70 / 500	37.7	45.2	52.9	68.4	67.7	98.5	97.8	189.7	187.4	299.0	299.1	561.5	28.6	-4.1	-24.5	-2.0	-22.5	10.2
15.24 / 600	45.3	54.3	63.5	82.1	81.3	118.2	117.4	227.8	224.9	358.9	359.1	674.1	34.4	-4.9	-29.4	-2.5	-27.0	12.3
17.78 / 700	52.9	63.4	74.1	95.8	95.0	138.0	137.0	265.8	262.5	418.8	419.2	-	40.2	-5.7	-34.3	-2.9	-31.5	14.3
20.32 / 800	60.4	72.5	84.8	109.6	108.6	157.7	156.6	303.9	300.1	478.7	479.3	-	45.9	-6.5	-39.2	-3.3	-36.0	16.3
22.86 / 900	68.0	81.5	95.4	123.3	122.2	177.5	176.3	342.0	337.7	538.7	539.4	-	51.7	-7.4	-44.1	-3.7	-40.4	18.4
25.40 / 1000	75.6	90.6	106.0	137.1	135.8	197.3	195.9	380.0	375.2	598.5	599.4	-	57.5	-8.2	-49.0	-4.1	-44.9	20.4

- The value for L (distance to screen) varies slightly within ±5% depending on the zoom lens characteristics.
- At the shortest projection distance, the zoom lens characteristics may cause slight image distortion.
- When vertical keystone correction is used, the image is corrected in the direction that reduces its projected size.

NOTE: When the ET-D75LE50 is mounted, the optical lens shift function cannot be used.

**Calculation of the projection distance**

For a screen size different from the above, use the equation below to calculate the projection distance.

**Aspect ratio 16:9****Zoom lenses**

ET-D75LE6	minimum	$L (m) = (\text{diagonal screen size in inches}) \times 0.0231 - 0.0566$
	maximum	$L (m) = (\text{diagonal screen size in inches}) \times 0.0277 - 0.0736$
ET-D75LE10	minimum	$L (m) = (\text{diagonal screen size in inches}) \times 0.0324 - 0.0857$
	maximum	$L (m) = (\text{diagonal screen size in inches}) \times 0.0419 - 0.1085$
ET-D75LE20	minimum	$L (m) = (\text{diagonal screen size in inches}) \times 0.0415 - 0.0832$
	maximum	$L (m) = (\text{diagonal screen size in inches}) \times 0.0602 - 0.1162$
ET-D75LE30	minimum	$L (m) = (\text{diagonal screen size in inches}) \times 0.0598 - 0.1131$
	maximum	$L (m) = (\text{diagonal screen size in inches}) \times 0.1160 - 0.1765$
ET-D75LE40	minimum	$L (m) = (\text{diagonal screen size in inches}) \times 0.1145 - 0.1577$
	maximum	$L (m) = (\text{diagonal screen size in inches}) \times 0.1826 - 0.1615$
ET-D75LE8	minimum	$L (m) = (\text{diagonal screen size in inches}) \times 0.1831 - 0.3862$
	maximum	$L (m) = (\text{diagonal screen size in inches}) \times 0.3430 - 0.3598$

**Fixed-focus lens**

ET-D75LE50		$L (m) = (\text{diagonal screen size in inches}) \times 0.0176 - 0.0713$
------------	--	--

- Distances calculated with the above equations will include slight deviations.



**Shift range**

Optical axis shift function allows to shift the position of a projected image as shown below.

- When the lens except the ET-D75LE6 is mounted

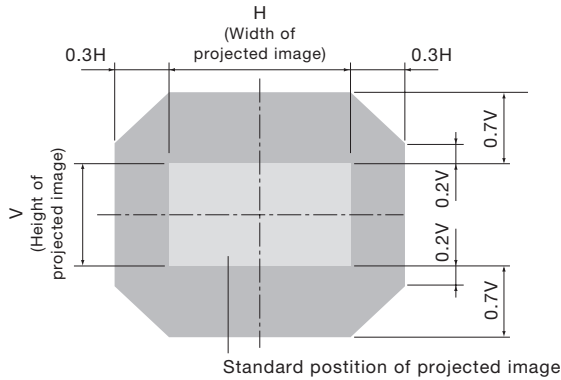

- When the ET-D75LE6 is mounted

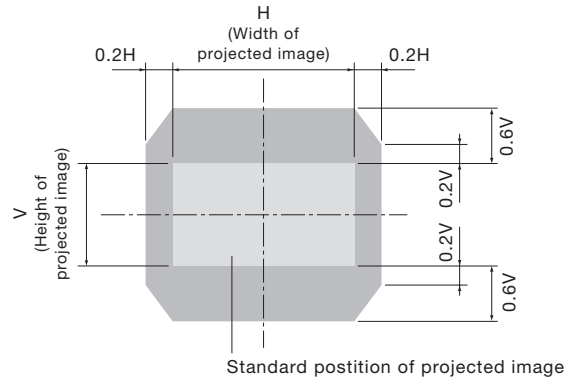

**NOTE:** Because the ET-D75LE50 is a fixed short-throw lens, the lens shift function cannot be used with it.

**Installable angle**

Install the projector at an angle within the range shown below.

- **Vertical direction**

The projector may be installed at a vertical angle of 360°.

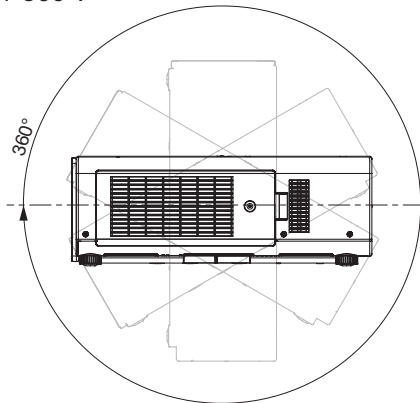

- **Horizontal direction**

The projector may be installed at a horizontal angle of ±15°.

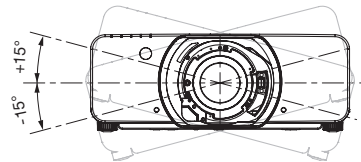

- **Vertical direction in portrait mode with the ET-LAD320P/LAD320PW mounted**

The projector may be installed at a vertical angle of ±15°.

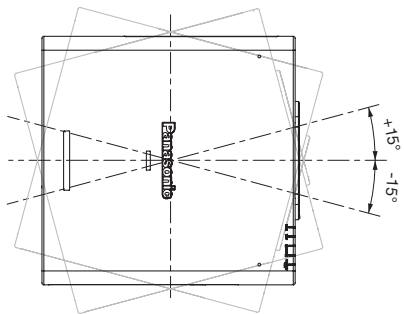

- **Horizontal direction in portrait mode with the ET-LAD320P/LAD320PW mounted**

The projector may be installed at a horizontal angle of ±15°.

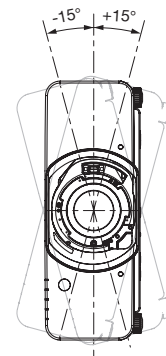

**NOTE:** The projector cannot be vertically installed all by itself. Also, the terminal side must face downward when vertically installed.

**List of compatible signals**

The signals that can be input to this projector are shown in the table below. Horizontal scanning frequencies of 15 kHz to 100 kHz, vertical scanning frequencies of 24 Hz to 120 Hz, and a dot clock of 162 MHz maximum can be input.

**NOTE:** The native resolution of this projector is 1,366 × 768 pixels. If the display resolution of the input signal is different from the native resolution, image compression or expansion will be used to convert the input signal to a level within the native resolution.

Display mode	Display resolution (dots) <sup>*1</sup>	Scanning frequency		Dot clock frequency (MHz)	Format
		H (kHz)	V (kHz)		
NTSC/NTSC4.43/PAL-M/PAL60	720 × 480i	15.7	59.9	–	VIDEO/S-VIDEO
PAL/PAL-N/SECAM	720 × 576i	15.6	50.0	–	
525i (480i)	720 × 480i	15.7	59.9	13.5	RGB/YCbCr
625i (576i)	720 × 576i	15.6	50.0	13.5	
525i (480i)	720(1440) × 480i <sup>*2</sup>	15.7	59.9	27.0	HDMI/DVI-D
625i (576i)	720(1440) × 576i <sup>*2</sup>	15.6	50.0		
525p (480p)	720 × 483	31.5	59.9	27.0	HDMI/DVI-D/ RGB/YCbCr
625p (576p)	720 × 576	31.3	50.0		
750 (720)/60p	1280 × 720	45.0	60.0	74.3	HDMI/DVI-D/ RGB/YCbPr
750 (720)/50p		37.5	50.0		
1125 (1080)/60i	1920 × 1080i	33.8	60.0		
1125 (1080)/50i		28.1	50.0		
1125 (1080)/25p	1920 × 1080	28.1	25.0		
1125 (1080)/24p		27.0	24.0		
1125 (1080)/24sF	1920 × 1080i	27.0	48.0		
1125 (1080)/30p	1920 × 1080	33.8	30.0		
1125 (1080)/60p		67.5	60.0	148.5	HDMI/DVI-D/ RGB/YCbPr
1125 (1080)/50p		56.3	50.0		
VGA400	640 × 400	31.5	70.1	25.2	HDMI/DVI-D/RGB
		37.9	85.1	31.5	
VGA480	640 × 480	31.5	59.9	25.2	
		35.0	66.7	30.2	
		37.9	72.8	31.5	
		37.5	75.0	31.5	
		43.3	85.0	36.0	
SVGA	800 × 600	35.2	56.3	36.0	
		37.9	60.3	40.0	
		48.1	72.2	50.0	
		46.9	75.0	49.5	
		53.7	85.1	56.3	
MAC16	832 × 624	49.7	74.6	57.3	
XGA	1024 × 768	39.6	50.0	51.9	
		48.4	60.0	65.0	
		56.5	70.1	75.0	
		60.0	75.0	78.8	
		65.5	81.6	86.0	
		68.7	85.0	94.5	
		81.4	100.0	113.3	
		98.8	120.0	139.1	
MXGA	1152 × 864	53.7	60.0	81.6	
		64.0	70.0	94.2	
		67.5	74.9	108.0	
		76.7	85.0	121.5	
MAC21	1152 × 870	68.7	75.1	100.0	

\*1 The “i” appearing after the resolution indicates an interlaced signal.

\*2 Pixel repetition signal only.

Display mode	Display resolution (dots)	Scanning frequency		Dot clock frequency (MHz)	Format	
		H (kHz)	V (kHz)			
1280 × 720	1280 × 720	37.1	49.8	60.5	HDMI/DVI-D/RGB	
		44.8	59.9	74.5		
		76.3	100.0	131.8		
		92.6	120.0	161.6		
1280 × 768	1280 × 768	39.6	49.9	65.3		
		47.8	59.9	79.5		
	1280 × 768*	47.4	60.0	68.3		
	1280 × 768	60.3	74.9	102.3		
1280 × 800	1280 × 800	68.6	84.8	117.5		
		41.3	50.0	68.0		
	1280 × 800*	49.7	59.8	83.5		
	1280 × 800	49.3	59.9	71.0		
MSXGA	1280 × 1024	62.8	74.9	106.5		
		71.6	84.9	122.5		
		60.0	60.0	108.0		
		52.4	50.0	88.0		
SXGA	1280 × 1024	64.0	60.0	108.0		
		72.3	66.3	125.0		
		78.2	72.0	135.1		
		80.0	75.0	135.0		
1366×768	1366 × 768	91.1	85.0	157.5		
		47.7	59.8	85.5		
		39.6	49.9	69.0		
		54.1	50.0	99.9		
SXGA+	1400 × 1050	64.0	60.0	108.0		
		65.2	60.0	122.6		
		65.3	60.0	121.8		
		78.8	72.0	149.3		
WXGA+	1440 × 900	82.2	75.0	155.9		
		55.9	59.9	106.5		
		46.3	49.9	86.8		
		75.0	60.0	162.0		
UXGA60	1600 × 1200	65.3	60.0	146.3		
		54.1	50.0	119.5		
		55.6	49.9	141.5		
		66.6	59.9	138.5		
WSXGA+	1680 × 1050	67.2	60.0	173.0	RGB	
		1920 × 1080	61.8	49.9		158.3
	1920×1080	1920 × 1200*	74.0	60.0	154.0	HDMI/DVI-D/RGB
		1920 × 1200	74.6	59.9	193.3	

\* Compliant with VESA CVT-RB (Coordinated Video Timing-Reduced Blanking).

List of compatible 3D signals

The 3D signals that can be input to this projector are shown in the table below.

Display mode	Display resolution (dots)*1	Scanning frequency		Dot clock frequency (MHz)	HDMI			DVI			
		H (kHz)	V (kHz)		Frame packing	Side by side*2	Top and bottom	Side by side*2	Top and bottom	Line by line	Frame sequential
750 (720)/60p	1280 × 720	45.0	60.0	74.3	Yes	Yes	Yes	Yes	Yes	Yes	-
750 (720)/50p		37.5	50.0	74.3							
1125 (1080)/60i	1920 × 1080i	33.8	60.0	74.3	-	-	-	-	-	-	-
1125 (1080)/50i		28.1	50.0	74.3							
1125 (1080)/25p	1920 × 1080	28.1	25.0	74.3	-	-	-	-	-	-	-
1125 (1080)/24p		27.0	24.0	74.3	Yes	Yes	Yes				
1125 (1080)/24sF	1920 × 1080i	27.0	48.0	74.3	-	-	-	-	-	-	-
1125 (1080)/30p	1920 × 1080	33.8	30.0	74.3	-	-	-	-	-	-	-
1125 (1080)/60p		67.5	60.0	148.5							
1125 (1080)/50p		56.3	50.0	148.5							
VGA480		640 × 480	31.5	59.9							
SVGA	800 × 600	37.9	60.3	40.0	-	-	-	-	-	-	-
XGA	1024 × 768	39.6	50.0	51.9							
		48.4	60.0	65.0							
		81.4	100.0	113.3							
		98.8	120.0	139.1	-	-	-	-	-	-	Yes
MXGA	1152 × 864	53.7	60.0	81.6	-	-	-	-	-	-	-
1280 × 720	1280 × 720	37.1	49.8	60.5							
		44.8	59.9	74.5							
		76.3	100.0	131.8							
		92.6	120.0	161.6	-	-	-	-	-	-	Yes
1280 × 768	1280 × 768	39.6	49.9	65.3	-	-	-	-	-	-	-
		47.8	59.9	79.5							
	1280 × 768 *3	47.4	60.0	68.3	-	-	-	-	-	-	-
1280 × 800	1280 × 800	41.3	50.0	68.0							
		49.7	59.8	83.5							
		49.3	59.9	71.0							
MSXGA	1280 × 960	60.0	60.0	108.0	-	-	-	-	-	-	-
SXGA	1280 × 1024	52.4	50.0	88.0							
		64.0	60.0	108.0	-	-	-	-	-	-	-
1366 × 768	1366 × 768	47.7	59.8	85.5							
		39.6	49.9	69.0	-	-	-	-	-	-	-
SXGA+	1400 × 1050	54.1	50.0	99.9							
		64.0	60.0	108.0							
		65.2	60.0	122.6							
		65.3	60.0	121.8							
WXGA+	1440 × 900	55.9	59.9	106.5	-	-	-	-	-	-	-
		46.3	49.9	86.8							
UXGA60	1600 × 1200	75.0	60.0	162.0	-	-	-	-	-	-	-
WSXGA+	1680 × 1050	65.3	60.0	146.3							
		54.1	50.0	119.5	-	-	-	-	-	-	-
1920 × 1080	1920 × 1080	55.6	49.9	141.5							
	1920 × 1080 *3	66.6	59.9	138.5	-	-	-	-	-	-	-
WUXGA	1920 × 1200	61.8	49.9	158.3							
	1920 × 1200 *3	74.0	60.0	154.0							

\*1 The "i" appearing after the resolution indicates an interlaced signal.  
 \*2 Compatible with half-resolution signals.  
 \*3 Compliant with VESA CVT-RB (Coordinated Video Timing-Reduced Blanking).

Display mode	Display resolution (dots)*1	Scanning frequency		Dot clock frequency (MHz)	RGB1/RGB2				SD1/SDI2			HDMI & DVI	RGB1 & RGB2	SD1 & SDI2	3G-SDI Level B										
		H (kHz)	V (kHz)		Side by side*2	Top and bottom	Line by line	Frame sequential	Side by side*2	Top and bottom	Line by line	Simultaneous	Simultaneous	Simultaneous	Simultaneous										
750 (720)/60p	1280 × 720	45.0	60.0	74.3	Yes	Yes	Yes	-	Yes	Yes	Yes	Yes	Yes	Yes	Yes	Yes*3									
750 (720)/50p		37.5	50.0	74.3																					
1125 (1080)/60i	1920 × 1080i	33.8	60.0	74.3																					
1125 (1080)/50i		28.1	50.0	74.3																					
1125 (1080)/25p	1920 × 1080	28.1	25.0	74.3																					
1125 (1080)/24p		27.0	24.0	74.3																					
1125 (1080)/24sF	1920 × 1080i	27.0	48.0	74.3																					
1125 (1080)/30p	1920 × 1080	33.8	30.0	74.3																					
1125 (1080)/60p		67.5	60.0	148.5													Yes*3	Yes*3							
1125 (1080)/50p		56.3	50.0	148.5																					
VGA480	640 × 480	31.5	59.9	25.2	-	-	-	-	-	-	-	-	-	-	-	-									
SVGA	800 × 600	37.9	60.3	40.0																					
XGA	1024 × 768	39.6	50.0	51.9																					
		48.4	60.0	65.0																					
		81.4	100.0	113.3	-	-	-	-	-	-	-	-	-	-	-	-									
		98.8	120.0	139.1																					
MXGA	1152 × 864	53.7	60.0	81.6																					
1280 × 720	1280 × 720	37.1	49.8	60.5																					
		44.8	59.9	74.5	-	-	-	-	-	-	-	-	-	-	-	-	-								
		76.3	100.0	131.8																					
		92.6	120.0	161.6																					
1280 × 768	1280 × 768	39.6	49.9	65.3	Yes	-	-	-	-	-	-	-	-	-	-	-	-								
		47.8	59.9	79.5																					
	1280 × 768 *4	47.4	60.0	68.3	-	-	-	-	-	-	-	-	-	-	-	-	-								
1280 × 800	1280 × 800	41.3	50.0	68.0																					
		49.7	59.8	83.5	-	-	-	-	-	-	-	-	-	-	-	-	-								
	1280 × 800 *4	49.3	59.9	71.0																					
MSXGA	1280 × 960	60.0	60.0	108.0	-	-	-	-	-	-	-	-	-	-	-	-	-								
SXGA	1280 × 1024	52.4	50.0	88.0																					
		64.0	60.0	108.0	-	-	-	-	-	-	-	-	-	-	-	-	-								
1366 × 768	1366 × 768	47.7	59.8	85.5																					
		39.6	49.9	69.0	Yes	-	-	-	-	-	-	-	-	-	-	-	-								
SXGA+	1400 × 1050	54.1	50.0	99.9																					
		64.0	60.0	108.0																					
		65.2	60.0	122.6																					
		65.3	60.0	121.8	-	-	-	-	-	-	-	-	-	-	-	-	-								
WXGA+	1440 × 900	55.9	59.9	106.5																					
		46.3	49.9	86.8	-	-	-	-	-	-	-	-	-	-	-	-	-								
UXGA60	1600 × 1200	75.0	60.0	162.0																					
WSXGA+	1680 × 1050	65.3	60.0	146.3	-	-	-	-	-	-	-	-	-	-	-	-	-								
		54.1	50.0	119.5																					
1920 × 1080	1920 × 1080	55.6	49.9	141.5	-	-	-	-	-	-	-	-	-	-	-	-	-								
	1920 × 1080 *4	66.6	59.9	138.5																					
WUXGA	1920 × 1200	61.8	49.9	158.3	-	-	-	-	-	-	-	-	-	-	-	-	-								
	1920 × 1200 *4	74.0	60.0	154.0																					

\*1 The "i" appearing after the resolution indicates an interlaced signal.  
 \*2 Compatible with half-resolution signals.  
 \*3 SDI 1 only.  
 \*4 Compliant with VESA CVT-RB (Coordinated Video Timing-Reduced Blanking).

**Serial connector**

The serial connector complies with RS-232C. To control the projector from a personal computer, commands must be input through communication software, based on the format and satisfying the communication conditions shown below.

**Pin assignments and signal names**

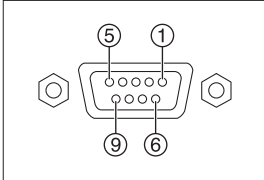

No.	Signal name	Description	No.	Signal name	Description
1	-	NC	6	-	NC
2	TXD	Send data	7	CTS	Connected internally
3	RXD	Receive data	8	RTS	Connected internally
4	-	NC	9	-	NC
5	GND	Ground			

D-sub 9-pin (female) Serial input

**Pin assignments and signal names**

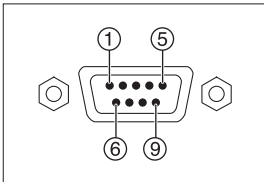

No.	Signal name	Description	No.	Signal name	Description
1	-	NC	6	-	NC
2	RXD	Receive data	7	RTS	Connected internally
3	TXD	Send data	8	CTS	Connected internally
4	-	NC	9	-	NC
5	GND	Ground			

D-sub 9-pin (male) Serial output

**Communication conditions (factory setting)**

Signal level	RS-232C-compliant
Synchronization method	Start-stop synchronization
Baud rate	9,600 bps
Parity	None
Character length	8 bits
Stop bit	1 bit
X parameter	None
S parameter	None

**Basic format**

Transmission from the computer begins with STX, then the ID, command, parameter, and ETX are sent in this order. Add parameters according to the details of control.

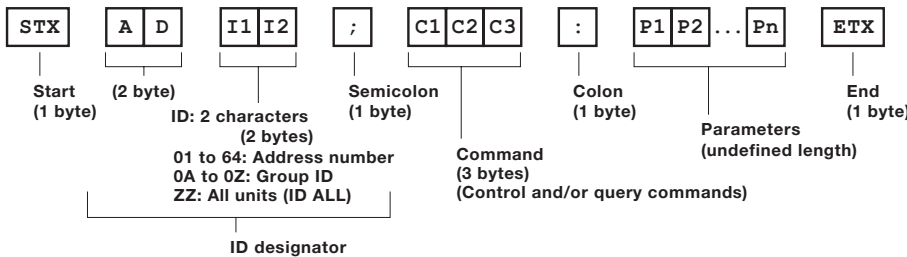

**CAUTION**

- It may not be possible to send or receive commands for about 10 to 60 seconds when the lamp is first turned on. If this occurs, wait for 60 seconds, then try sending or receiving again.
- When sending multiple commands, be sure to wait for at least 0.5 second after receiving a response from the projector before sending the next command.
- Additional time is sometimes required for response due to processing inside the projector. Set the time-out period for command response to 10 seconds or more.
- When using two or more units:
  - 1) Set different IDs for each unit.
  - 2) Designate only one unit as RESPONSE (ID ALL) ON and the rest as RESPONSE (ID ALL) OFF.
  - 3) Each group should have only one RESPONSE (ID GROUP) ON and the rest should be RESPONSE (ID GROUP) OFF.

Cable specifications

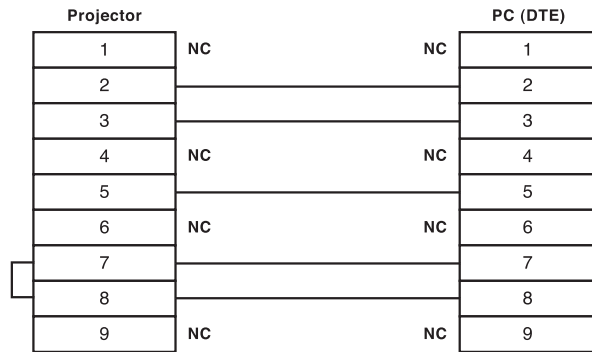

Control commands

Command : Parameter	Function		Callback
<b>PON</b>	POWER (STANDBY)	Standby power on	<b>PON</b>
<b>POF</b>		Standby power off	<b>POF</b>
<b>OSH : 0</b>	SHUTTER	Shutter off	<b>OSH : 0</b>
<b>OSH : 1</b>		Shutter on	<b>OSH : 1</b>
<b>IIS : SD1</b>	INPUT SELECT	HDMI	<b>IIS : HD1</b>
<b>IIS : DVI</b>		DVI	<b>IIS : DVI</b>
<b>IIS : RG1</b>		RGB 1	<b>IIS : RG1</b>
<b>IIS : RG2</b>		RGB 2	<b>IIS : RG2</b>
<b>IIS : VID</b>		Video	<b>IIS : VID</b>
<b>VXX : RYC1=+00000</b>	RGB INPUT SETTING	RGB/Y · PB · PR	<b>VXX : RYC1=+00000</b>
<b>VXX : RYC1=+00001</b>		S-Video	<b>VXX : RYC1=+00001</b>
<b>LPM : 0</b>	LAMP SELECT	Dual (two lamps)	<b>LPM : 0</b>
<b>LPM : 1</b>		Single lamp	<b>LPM : 1</b>
<b>LPM : 2</b>		Lamp 1	<b>LPM : 2</b>
<b>LPM : 3</b>		Lamp 2	<b>LPM : 3</b>
<b>OLP : 0</b>	Lamp power	High	<b>OLP : 0</b>
<b>OLP : 8</b>		Middle	<b>OLP : 8</b>
<b>OLP : 1</b>		Eco	<b>OLP : 1</b>
<b>VSE : 1</b>	ASPECT RATIO SWITCHING	Standard/VID Auto	<b>VSE : 1</b>
<b>VSE : 2</b>		4:3	<b>VSE : 2</b>
<b>VSE : 5</b>		16:9	<b>VSE : 5</b>
<b>VSE : 6</b>		HV fit	<b>VSE : 6</b>
<b>VSE : 9</b>		H fit	<b>VSE : 9</b>
<b>VSE : 10</b>		V fit	<b>VSE : 10</b>
<b>OPP : 0</b>	P IN P SELECT	Off	<b>OPP : 0</b>
<b>OPP : 1</b>		User 1	<b>OPP : 1</b>
<b>OPP : 2</b>		User 2	<b>OPP : 2</b>
<b>OPP : 3</b>		User 3	<b>OPP : 3</b>
<b>OAS</b>	AUTO SETUP		<b>OAS</b>
<b>VPM : NAT</b>	PICTURE MODE	Natural	<b>VPM : NAT</b>
<b>VPM : STD</b>		Standard	<b>VPM : STD</b>
<b>VPM : DYN</b>		Dynamic	<b>VPM : DYN</b>
<b>VPM : CIN</b>		Cinema	<b>VPM : CIN</b>
<b>VPM : GRA</b>		Graphic	<b>VPM : GRA</b>
<b>VPM : DIC</b>		DICOM	<b>VPM : DIC</b>
<b>VXX : DLVI0=+00000</b>	SYSTEM DAYLIGHT VIEW	Off	<b>VXX : DLVI0=+00000</b>
<b>VXX : DLVI0=+00001</b>		1	<b>VXX : DLVI0=+00001</b>
<b>VXX : DLVI0=+00002</b>		2	<b>VXX : DLVI0=+00002</b>
<b>VXX : DLVI0=+00003</b>		3	<b>VXX : DLVI0=+00003</b>
<b>OTE : 4</b>	COLOR TEMPERATURE	User 1	<b>OTE : 4</b>
<b>OTE : 9</b>		User 2	<b>OTE : 9</b>
<b>OTE : 10</b>		Default	<b>OTE : 10</b>
<b>OTE : p1p2p3p4</b>		3200 K – 9300 K (100 K steps)	<b>OTE : p1p2p3p4</b>
<b>TSD : y1y2y3y4m1m2d1d2w</b>	DATE	Date setting	<b>TSD : y1y2y3y4m1m2d1d2w</b>
<b>TST : h1h2m1m2s1s2</b>	TIME	Time setting	<b>TST : h1h2m1m2s1s2</b>
<b>OOS : 0</b>	ON SCREEN	On-screen display off	<b>OOS : 0</b>
<b>OOS : 1</b>		On-screen display on	<b>OOS : 1</b>

\* Do not send PON, POF, OSH, or OLP commands continuously in a short period of time. Doing so may burst the lamp or shorten the lamp replacement cycle.

\* When a command that cannot be executed, the projector will send an ER401 command in reply.

**Status request commands**

Command:Parameter	Function	Callback	Description
<b>QPW</b>	Main power status	000	Off
		001	On
<b>QSH</b>	Shutter function status	0	Off
		1	On
<b>QIN</b>	Input signal status	HD1	HDMI
		DVI-D	DVI
		RG1	RGB 1
		RG2	RGB 2
		VID	Video
<b>QSL</b>	Lamp operation mode status	0	Dual (two lamps)
		1	Single lamp
<b>QLP</b>	Lamp power mode status	0	High
		8	Middle
		1	Eco
		3	Off
<b>QPP</b>	P in P status	0	Off
		1	User 1
		2	User 2
		3	User 3
<b>QPM</b>	Picture mode status	NAT	Natural
		STD	Standard
		DYN	Dynamic
		CIN	Cinema
		GRA	Graphic
		DIC	DICOM
<b>QVX:DLVIO</b>	System daylight view status	DLVIO=+00000	Off
		DLVIO=+00001	1
		DLVIO=+00002	2
		DLVIO=+00003	3
<b>QST</b>	Projector run time	p1p2p3p4p5	00000h-99999h
<b>Q\$L:1</b>	Lamp 1 run time	p1p2p3p4	0000h-9999h
<b>Q\$L:2</b>	Lamp 2 run time	p1p2p3p4	0000h-9999h
<b>QTM:0</b>	Temperature status	p1p2p3p4/p5p6p7p8*1	p0 = Intake air
<b>QTM:1</b>			p1 = Around lamp
<b>QTM:2</b>			p2 = Optics module
<b>QGD</b>	Date setting status	y1y2y3y4m1m2d1d2w	yyyymmdd (day of week)*2
<b>QGT</b>	Time setting status	h1h2m1m2s1s2	hhmmss*3
<b>QOS</b>	On-screen display status	0	Off
		1	On

\*1 p1p2p3p4: Celsius (°C), p5p6p7p8: Fahrenheit (°F)

\*2 Day of week: Monday = 1, Tuesday = 2, ... Sunday = 7

\*3 Set the date and time to UTC (universal time coordinated).

\* When a wrong command is sent, the projector will send an ER401 or ER402 command in reply.

**Command example**

To set the on-screen display off, send the command as shown below.



**NOTE:** When sending commands without parameters, a colon (:) is not necessary.



### Notes on projector placement and operation

The projector uses a high-wattage lamp that becomes very hot during operation. Please observe the following precautions.

1. Never place objects on top of the projector while it is operating.
2. Make sure there is an unobstructed space of 500 mm (19-11/16") or more around the projector's exhaust openings.
3. Do not stack projector units directly on top of one another. If two units must be stacked for backup use in ordinary projection, use a method as shown below and provide ample space between the units to ensure that exhaust heat does not accumulate near the intake opening or around the units. Dual stacked projection is not recommended.
4. Make sure that nothing blocks the projector's air intake and exhaust openings. Also, install the projector so that cool or hot air from other air conditioning equipment does not flow directly toward the projector's air intake or exhaust openings.
5. Do not install the projector in an enclosed space. If it is necessary to install it in an enclosed space, add a separate ventilation system. If ventilation is insufficient, hot air will accumulate at the intake opening. This may cause the projector's protective circuit to interrupt projector operation.
6. If the projector is installed in an enclosed space, ensure that the temperature of the air surrounding the projector is between 0 °C and 45 °C (32 °F and 104 °F). Also make sure that the projector's intake and exhaust openings are not blocked. Even though the air surrounding the projector is 40 °C (104 °F) or less, if hot exhaust air accumulates inside the space, it may cause the projector's protective circuit to interrupt projector operation. Pay particular attention to the surrounding temperature conditions when planning the installation.
7. If the projector is not to be set on the floor using adjuster legs, install it by using the five ceilingmount screw holes (screw diameter: M6, length of each screw hole in the projector: 16 mm (5/8")). Provide a space of 5 to 10 mm (3/16" to 13/32") between the projector and the mounting surface by inserting metal spacers.

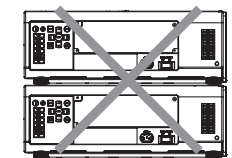
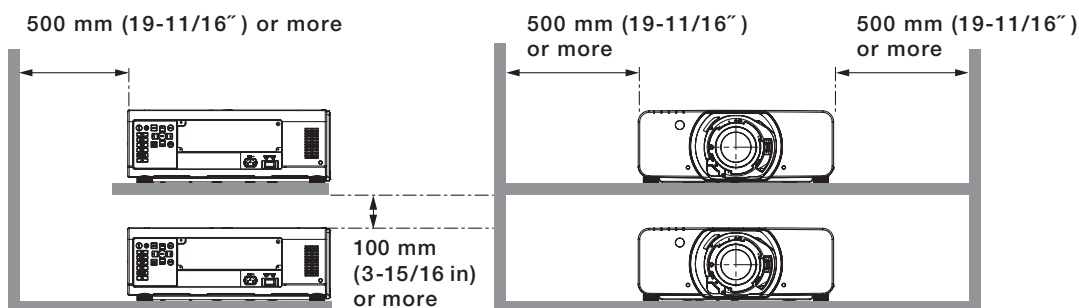

Do not stack projector units directly on top of one another.

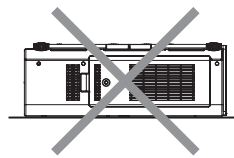

Do not support the projector unit by its top while it is in use.

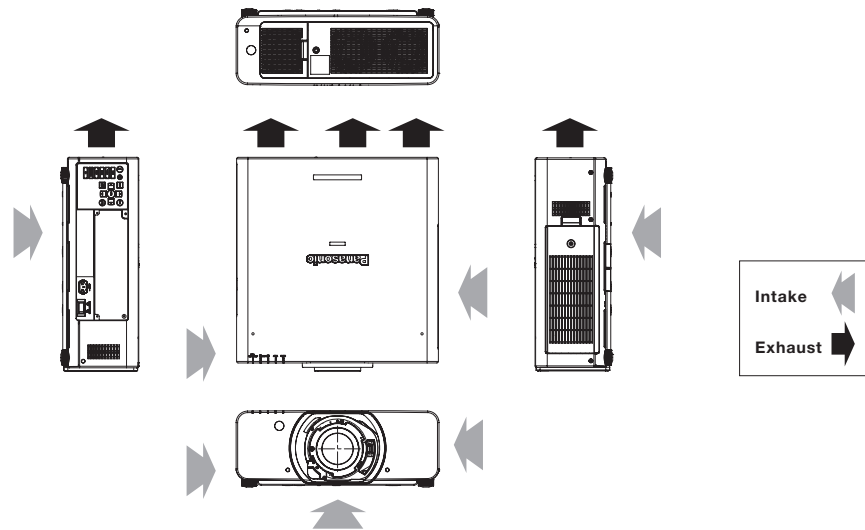
**Direction of air intake and exhaust****Operating the projector continuously**

1. If the projector is to be operated continuously one week, use the dual-lamp optical system's alternating lamp operation (lamp relay) function. The projector cannot be operated continuously one week in dual-lamp mode. Allow a minimum of two hours per day of non-operation time for each lamp if the projector is to be operated continuously for more than one week.
2. The lamp replacement cycle duration becomes shorter if the projector is operated repeatedly for short periods.

Weights and dimensions shown are approximate. Specifications and appearance are subject to change without notice. Product availability differs depending on region and country. This product may be subject to export control regulations.

DLP and the DLP logo are trademarks of Texas Instruments.  
HDMI, the HDMI logo and High-Definition Multimedia Interface are trademarks or registered trademarks of HDMI Licensing LLC in the United States and other countries.  
PJLink is a registered trademark, or a trademark application has been filed, in Japan, the United States, and other countries and regions.  
All other trademarks are the property of their respective trademark owners.