

BOSE[®]

VIRTUALLY INVISIBLE[®] 191 SPEAKERS

Installation Guide



SAFETY INFORMATION

Important words of caution

Please read this owner’s guide completely before you start. Then carefully consider your experience using the tools and taking the precautions referred to here. If you have doubts about doing this installation, you should contact either the dealer you purchased the product from, an electrician, or a professional audio/video installer. You can describe the job and request a cost estimate before committing to installation service.

⚠ WARNING: *Installation shall be in accordance with the applicable section of the National Electrical Code, ANSI/NFPA 70, and/or the National Fire Alarm Code, ANSI/NFPA 72, as applicable. The wiring method and compartment shall be such as not to interfere with the operation of the speaker.*

⚠ CAUTION: *Consult local building codes before you get started with this installation.*

⚠ CAUTION: *This product is not intended for use in Air-Handling Plenum Spaces.*

⚠ CAUTION: *Failure to follow the instructions in this owner’s guide voids all warranties on your speakers.*

Use these instructions with wood frame or similar construction only

Each speaker requires 8¹/₁₆ in. (20.5 cm) of horizontal space, and 14 in. (35.6 cm) of vertical space inside the wall or ceiling, plus a minimum of 4¹/₈ in. (10.5 cm) of depth from the face of wallboard that is a maximum of ³/₄ in. (1.9 cm) thick.

Bose recommends installing these speakers only in wood frame or similar construction where there is enough space between studs, as is found in 2 x 4 or 2 x 6 wall/ceiling construction. The instructions in this guide are specific to that type of installation only.

🎵 Note: *These speakers are not designed for installation in walls or ceilings of masonry.*

Important Safety Instructions

1. **Read these instructions** - for all components before using this product.
2. **Keep these instructions** - for future reference.
3. **Heed all warnings** - on the product and in the owner’s guide.
4. **Follow all instructions.**
5. **Do not block any ventilation openings, install in accordance with the manufacturer’s instructions.**
6. **Only use attachments/accessories specified by the manufacturer.**

Bose® Virtually Invisible® 191 Loudspeakers comply with the following specifications:

CE This product conforms to the EMC Directive 89/336/EEC and to the Low Voltage Directive 73/23/EEC. The complete Declaration of Conformity can be found on <www.bose.com>.

For your records

Serial numbers are located on the center rear of each of the Virtually Invisible® 191 speakers.

Serial numbers: _____ and _____

Dealer name: _____

Dealer phone: _____ Purchase date: _____

We suggest you keep your sales receipt and warranty card together with this owner’s guide.

INTRODUCTION	4
Before you begin...	4
What makes this speaker better also makes it different	4
PREPARATION	5
Unpacking	5
Other equipment you will need	5
Deciding on speaker placement	6
Three tips for determining speaker placement	6
Consider which shape you prefer for your speakers	7
Considering your wall type and the approach it requires	7
For placement in walls	7
For placement in ceilings	8
STEPS TO INSTALLING	9
Before you make any holes	9
Drill a pilot hole for testing the wall space	9
Using the template	9
Drilling the pilot hole	10
Testing the space behind the hole	11
Passing the pilot hole test	13
Repairing a pilot hole	13
Prepare the wall for inserting the speaker	13
Measure and mark the hole to be cut	13
Cutting the speaker hole	14
Reorienting or changing speaker frames	15
Reorienting the rectangular frame logo	15
Installing round speaker frames	15
Insert and wire the speaker	15
Insert the speaker into the opening	16
Make the speaker connections	17
Test the speaker now	17
Position the speaker all the way into the hole	17
Secure the speaker to the wall	18
Attaching rectangular grille frames	19
Attaching round grilles	19
REFERENCE	20
Painting the speakers	20
Painting the grille	20
Painting the frame	21
Help for the beginning installer	21
Optional items that will assist you:	21
Accessories that can help	22
Using speaker cord	22
Preparing the speaker cord	22
Before the wallboard goes up	22
Installing in a pre-wired room	23
Where the walls are finished	23
What to do when the room is not pre-wired	24
Installing in an exterior wall	26
Use special care in cutting through plaster and lath	26
Special considerations in cold climate regions	26
Troubleshooting	27
Customer service	27
Warranty period	27
Accessories	28
Technical information	28

INTRODUCTION

Before you begin...

CAUTION: Please be sure to read this guide carefully before you do any cutting. There are many factors to consider before proceeding with this type of installation.

Thank you for choosing to install Bose® Virtually Invisible® 191 speakers. Innovative engineering and advanced design enable these speakers to deliver Bose quality performance for big impact in spite of their small size.

Virtually Invisible® 191 speakers feature an Articulated Array® speaker configuration that delivers the type of clear, lifelike sound and even coverage known as Bose Stereo Everywhere® speaker performance.

What makes this speaker better also makes it different

When installed, Virtually Invisible® 191 speakers take up very little wall space. What isn't apparent is their advanced speaker enclosure design, shown in Figure 1. It ensures predictably fine performance wherever the speakers are installed, regardless of the size and shape of the wall space. It also helps prevent the speaker sound from invading other rooms, a common problem with installed speakers of more conventional design.

Figure 1

Speaker enclosure with the rectangular frame attached

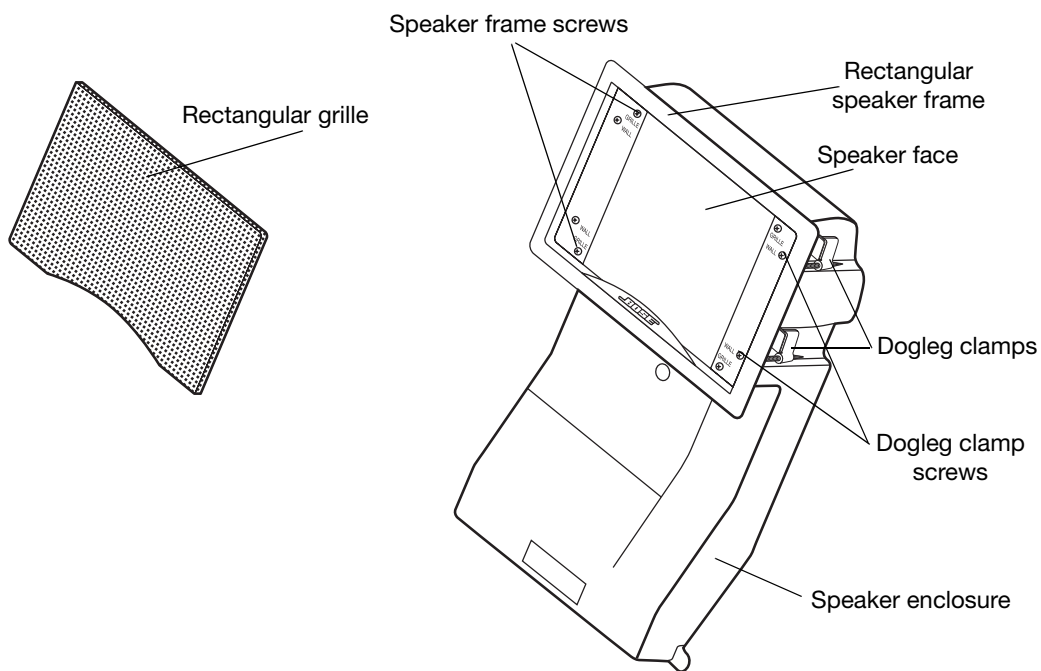

Unpacking

Carefully unpack the speakers. Check to be sure the carton includes all the parts shown in Figure 2. If any part of the speaker pair appears damaged, do not use them. Notify Bose or your authorized Bose dealer immediately. For Bose contact information, refer to the address list included in the carton.

Note: Now is a good time to find the serial numbers on the back of each speaker and copy the numbers onto your warranty card and in the “For your records” space on page 2.

Figure 2

Contents of the carton:

- 2 Speakers, rectangular frames attached
- 2 Rectangular speaker grilles
- 1 Rectangular paint shield
- 1 Template
- 2 Round speaker frames
- 2 Round speaker grilles
- 1 Circular paint shield

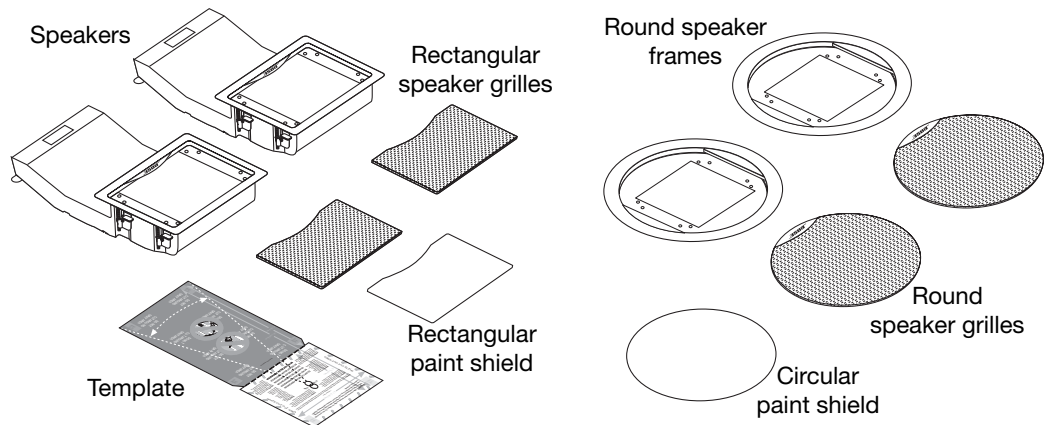

Other equipment you will need

Hardware for securing the speaker to a wall or ceiling comes attached to the speaker, but you will need a variety of other equipment and tools to install the speakers (Figure 3).

Please refer to “Help for the beginning installer” on page 21 for additional information on working with tools, materials, and other do-it-yourself information.

Figure 3

Items required to install the speakers as instructed

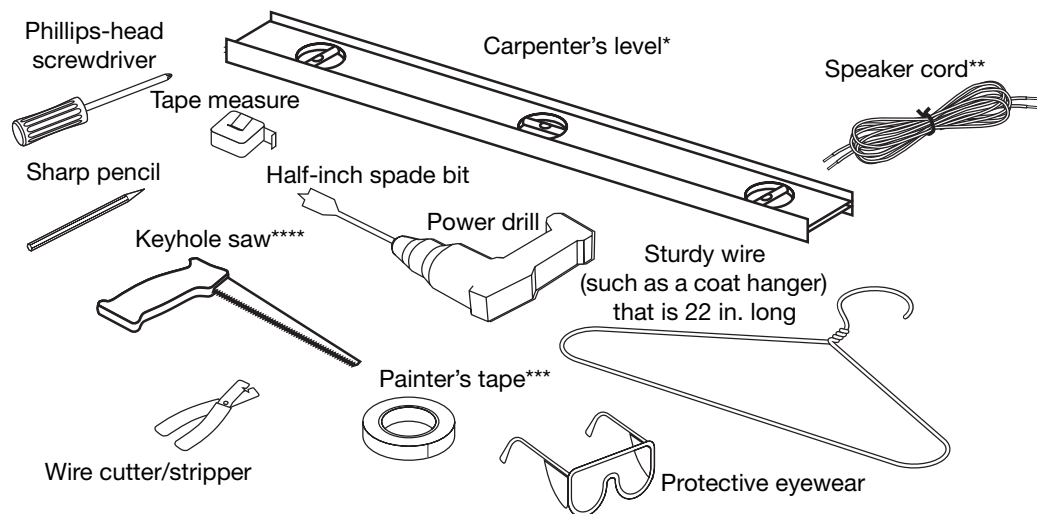

* Carpenter's level is suggested for use when installing speakers in a wall.

** Speaker cord specifications are provided in the Reference section of this guide.

*** Painter's tape or other tape with light adhesive that will not damage paint or wallpaper.

**** Cutting tool – For drywall: a keyhole saw, drywall saw, rotary cutting tool, or jigsaw.

For plaster and lath: a saber saw or a rotary cutting tool.

Deciding on speaker placement

The design of your new Virtually Invisible® 191 speakers makes them well-suited to either wall or ceiling installation. The location you choose will affect the procedure for installing them. Consider the options below, then follow the instructions that apply to your choices:

- How you will use the speakers?
 - for stereo sound at the front of a room or seating arrangement, or
 - as home theater front speakers or surround sound rear speakers
- What surface will you install them in?
 - an interior wall (abutting another room), or exterior wall (abutting outside), or ceiling
 - in finished (plaster and lath or wallboard), or new construction

Three tips for determining speaker placement

1. The template can be placed against a wall or ceiling to help determine the amount of space the speaker will need. Each speaker enclosure extends *into the wall or ceiling*, as shown in the gray DO NOT CUT area on the template (Figure 4). In a wall, the speaker may be inserted either up or down and will extend either above or below the grille.
2. Use of a stud finder can help ensure that the speaker hole is at least 4³/₄ in. (12 cm) from a stud or joist.
3. All electrical wiring, vents and plumbing pipes located inside the walls must be avoided (Figure 5 on page 7). Check with a trained professional to learn how to locate and avoid them.

Note: To prevent problems with condensation in cold climates where a humidifier is used, avoid inserting the speaker upside-down in an exterior wall.

Figure 4
Template

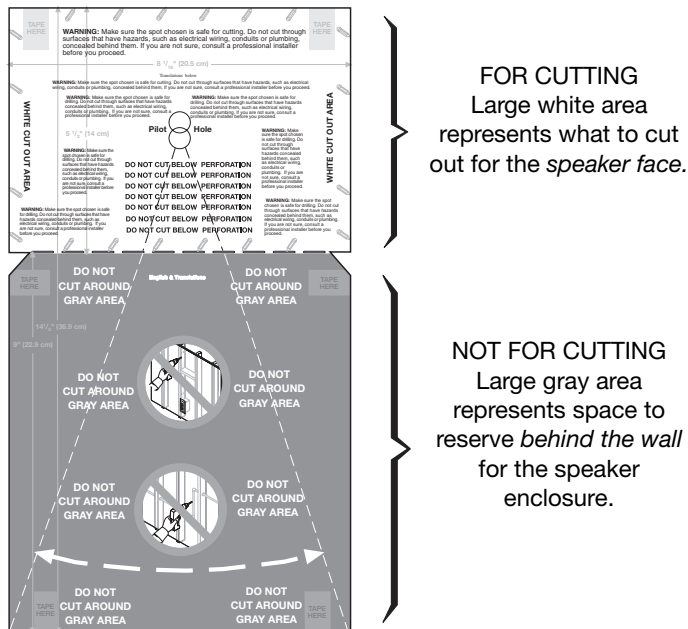

CAUTION: When installed, the speaker enclosure cannot be seen behind the wall or ceiling. Do not attempt to nail, cut, or drill on that surface area. Puncturing the speaker enclosure with a tool will seriously damage the speaker.

Figure 5

Cautions against unseen danger, such as (a) electrical wires or (b) plumbing pipes, behind the wallboard

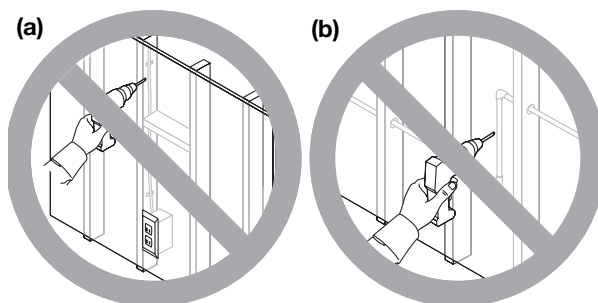

Consider which shape you prefer for your speakers

You have a choice of a rectangular or round speaker face – the part that is visible when the speaker is installed. Consider which shape will work best in the location you choose for the speakers. Typically, the rectangular shape is best suited for walls and the round shape is best suited for ceilings.

It is easy to remove the rectangular frames and replace them with round frames. You can do it now or wait until you know for sure where each speaker will fit. **However, be sure to make that change before you insert either speaker into the wall or ceiling.** The lip of the speaker frame prevents the speaker from slipping behind the wall and out of reach. Do not remove the frame while the speaker is in the wall. See “Reorienting or changing speaker frames” on page 15 for instructions for removing and replacing speaker frames.

Considering your wall type and the approach it requires

If you are installing the speakers in a pre-wired room of finished construction with 2 x 4 stud walls covered with wallboard, the placement of your speakers has already been determined. Please refer to “Steps to Installing” on page 9. These instructions cover installation of the speakers, with either a rectangular or round grille, in a wall or ceiling.

If your installation is different, use the information below to help determine where to place your speakers. As you decide where you want each speaker grille, use the guidelines below:

CAUTION: Do not install near any heat sources, such as halogen lamps, registers, stoves, or other apparatus (including amplifiers) that produce heat.

For placement in walls

- The two speakers should be a minimum of 5 ft. (1.5 m) apart.
- For in-wall speakers providing stereo at the front of the room or home theater surround sound from the rear, install so each speaker grille is 4 to 6 ft. (1.2 to 1.8 m) from the floor for best performance.
- For in-wall home theater front speakers, install the pair horizontally aligned with the center of the video screen (Figure 6 on page 8).

PREPARATION

- Place the in-wall center channel speaker above or below the video screen, centered between, but not on horizontal center with, the left and right front speakers. If a line were drawn between the left, center, and right front speakers a “V” shape would be created.
- The speakers should not be installed sideways in a wall; the enclosure should be either above or below the speaker face.

Figure 6

Orienting wall speakers for front home theater use

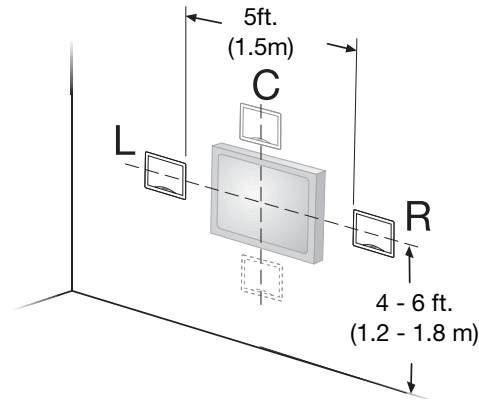
**For placement in ceilings**

When placing the speakers in the ceiling, please use the following guidelines. The direction the enclosures face will be determined by the spacing of the ceiling joists. The speaker enclosures should be parallel to the ceiling joists.

For best in-ceiling stereo performance:

- the speakers should each be placed an equal distance on either side of the primary listening area.

For best in-ceiling home theater performance:

- Place the right and left front speakers at equal distances to the right and left above the video screen.
- Place the center speaker above the center of the video screen.
- Place the surround speakers opposite the video screen wall, evenly spaced.

Before you make any holes

Be sure you have read and understand the considerations provided in “Preparation” starting on page 5, so you can proceed with confidence.

⚠ CAUTION: *If you are unsure of your ability to complete this process, contact a professional installer.*

- ✓ Small check marks call your attention to the tools you’ll need for the next step.
- Tips** offer ideas to make the job go easier and help you avoid mistakes.

Drill a pilot hole for testing the wall space

Before you make a large cut into the wallboard, check the space by probing behind the wall or ceiling through a small pilot hole. Time spent now can help ensure a successful installation.

🎵 Note: *If you are working in an exterior wall where there is insulation, it may be difficult to probe behind a pilot hole. You may prefer to eliminate this step and skip ahead to “Prepare the wall for inserting the speaker” on page 13. Do this only if you can be sure the insulation is malleable and that nothing else behind the wall will impede the installation.*

⚠ WARNING: *If you believe the insulation behind the wall may be composed of asbestos, do not drill or cut into that wall. Find a different location for the speakers instead.*

Using the template

- ✓ You will need a **sharp pencil** for this step.

The template shows where to drill two 1/2 in. (13 mm) pilot holes before you make an opening large enough for the entire speaker. You can then test the space behind the hole to make sure there is enough room for the speaker and that there are no materials blocking the installation.

Notice the dotted lines extending at an angle from the pilot hole to the bottom corners of the DO NOT CUT area on the template. Use them as a guideline to be sure there is enough room below the pilot hole for the length and width of the speaker enclosure.

To position the template

1. Select a spot on the wall or ceiling where you want the center of the speaker grille. Allow enough space for the speaker enclosure both above and below the pilot hole. You may need that second option if you find an impediment in the space below the hole.
2. Center the pilot-hole circles on the selected spot as you press the template to the wall.
3. Use a pencil to trace around the inside of the circles (Figure 7).
4. Remove the template.

Figure 7

Preparing to cut a pilot hole

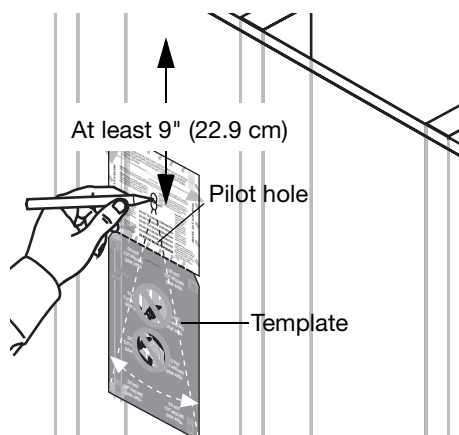

STEPS TO INSTALLING

Drilling the pilot hole

- ✓ You will need a **half-inch spade bit and power drill, or a special rotary cutting tool** for this step.
- ⚠ **WARNING:** Use eye protection and be sure to observe all safety precautions while using a drill or cutting tool (Figure 8).

Figure 8

Caution against drilling without eye protection

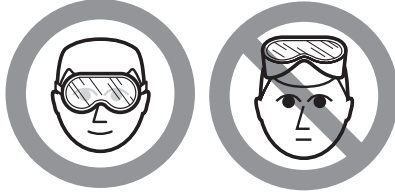

- ⚠ **WARNING:** Make sure the spot chosen is safe for cutting. Do not cut through surfaces that may have hazards such as electrical wiring, conduits, or plumbing concealed behind them. Follow all other safety precautions.

1. Center the tip of the drill bit in the top circle you have drawn.
2. Drill completely through the wallboard to create a hole that you can probe behind.

♪ **Note:** If you encounter insulation in the wall, it will be difficult, or impossible, to probe behind the pilot hole. If you are certain that your chosen location is free of hazards and impediments, you may choose to cut the hole for the speaker anyway, remove some of the malleable insulation, and proceed from there. Refer to “Prepare the wall for inserting the speaker” on page 13.

3. Drill the second hole just below the first one (Figure 9). This elongates the hole to allow for testing the space for the length of the speaker enclosure.

Figure 9

Using a spade bit with a power drill to create the pilot hole

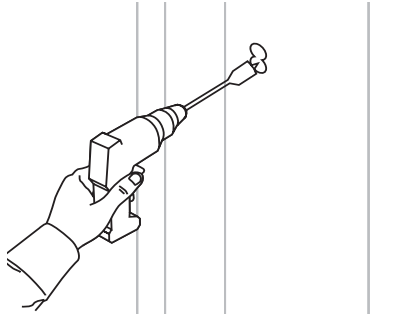

Testing the space behind the hole

Tip: You need a **tape measure** and a **sturdy wire** (such as a straightened coat hanger) 22 in. (55.9 cm) in length for this step.

1. Bend the wire as shown in Figure 10.

Figure 10

A 22-inch (55.9 cm) length of sturdy wire bent in two places

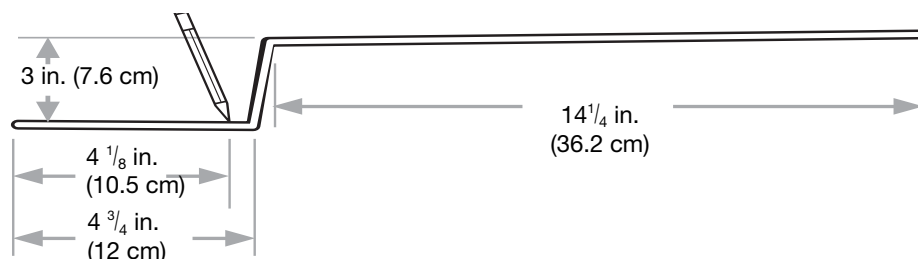

Tip: For greater accuracy, make the first bend a little long, measure again, and cut off the extra length at that end.

WARNING: If there is any possibility of electrical wiring in the space behind the wallboard, wrap the wire with electrical tape to prevent electric shock.

2. Make a mark $4\frac{1}{8}$ in. (10.5 cm) from the short end as an indicator of the proper front-to-back depth of the hole.
3. Use the bent wire to test for enough depth, front-to-back: Insert the short end of the wire into the hole and straight back (Figure 11). Probe to make sure nothing is in the way to a depth of $4\frac{1}{8}$ in. (10.5 cm). This indicates that the space behind the wallboard is deep enough for the front-to-back speaker dimension.

Figure 11

Checking the space for the depth of the speaker

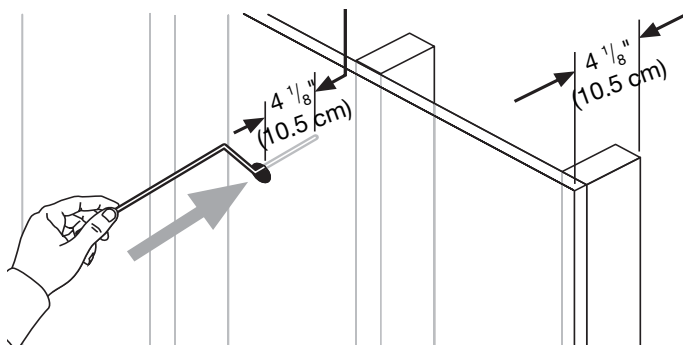

- If the wire goes in without a problem, proceed to step 4, below.
 - If you cannot insert the wire to the $4\frac{1}{8}$ -inch (10.5 cm) mark, you need to drill a new pilot hole elsewhere. Then repeat step 3.
4. Use the wire again to test the width, side-to-side: With the short end still in the hole, reposition it, as shown in Figure 12 on page 12, and rotate it 360° around the hole. This indicates if the wall space is wide enough on each side of the hole for the side-to-side dimension of the speaker.

STEPS TO INSTALLING

Figure 12

Checking the space for the width of the speaker

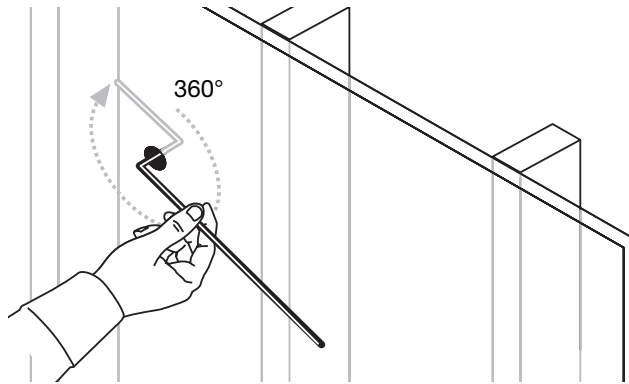

- If the wire goes around the 360° arc without a problem, proceed to step 5 below.
 - If you cannot rotate the wire all the way around up to the first bend, you need to drill a new pilot hole elsewhere. Then repeat the preceding steps 3 and 4.
5. Use the bent wire to check for enough length below the hole:
Holding the short end of the wire, insert the long end into the wall or ceiling and straight down from the hole (Figure 13a).

Tip: You may want to use the template for this step, as shown in Figure 13b.

- With the long end of the wire still in the hole, sweep it from side to side in a curve as shown on the template. This indicates if the wall or ceiling space is long enough and wide enough at the far end.

Tip: When testing for length, move the wire near the wall or ceiling, then farther back from it (as in Figure 13a, below).

Figure 13

Inserting the long end of the wire (a) and sweeping from side to side to check the length (b)

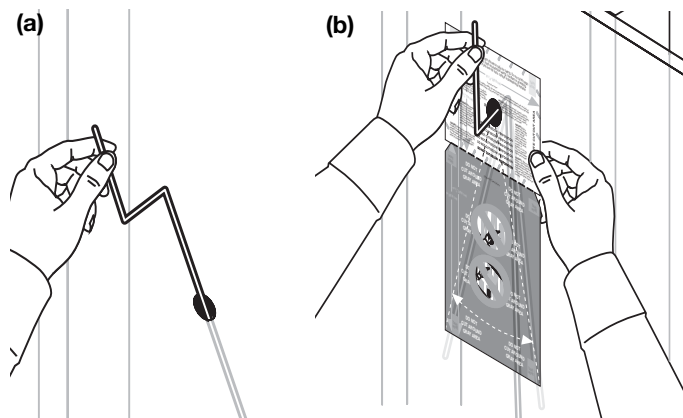

- If the wire goes in and sweeps from side to side at the far end without a problem, proceed to the next major step: “Prepare the wall for inserting the speaker” on page 13.
- If you find an impediment below the pilot hole, and you are working in an interior wall, insert the wire upward. If there are no impediments above the pilot hole, you can install the speaker upside-down. If you are working in an exterior wall, installing the speaker upside-down is not recommended. In this case, if you find an impediment you need to drill a new pilot hole elsewhere. Then repeat the preceding steps 3, 4, and 5.

Passing the pilot hole test

If you have successfully determined that this location will work for one speaker, test the wall or ceiling for the second speaker before making any larger holes. Refer to “Drill a pilot hole for testing the wall space” on page 9 and repeat those steps.

If the first speaker location is fine, but the second is not, you may want to relocate both speakers.

Repairing a pilot hole

To patch a pilot hole, fill it with spackle. Let the spackle dry, then add more until the hole is slightly overfilled. When it is thoroughly dry, sand the area to make it flush with the wall.

Prepare the wall for inserting the speaker

Use care in the steps that follow to ensure satisfaction with the end result.

- ⚠ **CAUTION:** Now is a good time to reconsider your comfort level with this job. If you have doubts about cutting into or running cord behind the wall, it is best to stop here. Contact a professional installer, describe the job, and request a cost estimate before engaging the installer's services.
- ⚠ **WARNING:** If you believe insulation in a wall may contain asbestos, do not cut into the wall. Find a different location for installing the speakers instead.

Measure and mark the hole to be cut

- ✓ You need a **carpenter's level**, a **sharp pencil**, and **optional tape** with the template to complete this step.
 1. Position the template carefully over the pilot hole where you want to install one speaker.
 2. Make sure the template is level (Figure 14).

Figure 14

Making sure the template is straight

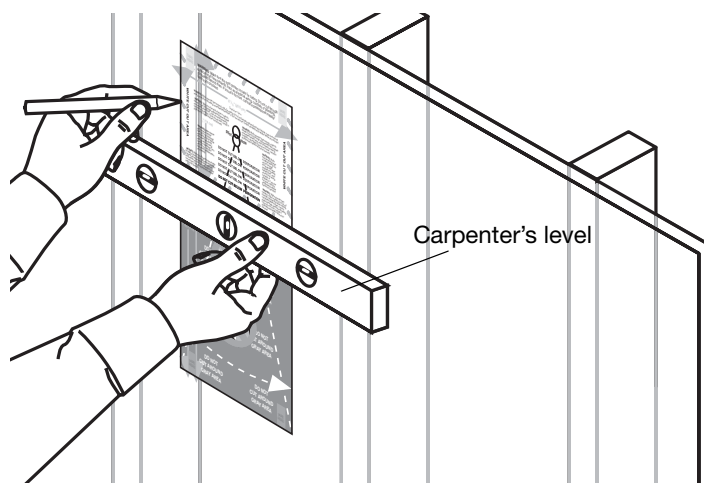

3. Tape or hold the template firmly in place as you trace around the sides and upper edge of the WHITE CUT-OUT AREA portion.

STEPS TO INSTALLING

4. Make a dotted line, using the slotted holes along the bottom of the WHITE CUT-OUT AREA portion, for the bottom edge of the hole.
5. Remove the template.

Tip: If necessary, use tape to hold the template temporarily in place (see TAPE HERE on the template). Then run your pencil along the entire template edge, except where there is tape.

Cutting the speaker hole

- ✓ You need a **small saw or specialized cutting tool (for example, a keyhole or drywall saw)** for this step of the installation.

WARNING: Use eye protection (Figure 15) and be sure to observe all safety precautions while using the saw or cutting tool.

Figure 15

Caution against drilling without eye protection

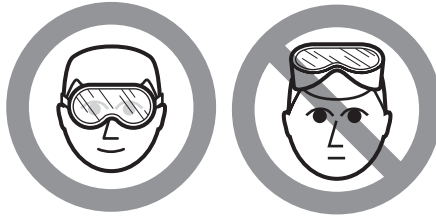

1. It is best to drill holes *inside* each corner of the rectangular outline you have drawn, before you begin cutting. Insert the blade into the pilot hole and cut down and at an angle until you reach one pencil line.

Tip: While it is important to cut carefully, remember that the speaker frame overlaps the wallboard by $\frac{1}{4}$ inch (0.6 cm) when the speaker is in place. Minor cutting inaccuracies will be hidden behind that frame.

2. Cut around three of four sides of the drawn outline, *not* all the way around (Figure 16a).

WARNING: Keep fingers away from the cutting blade.

3. Hook your finger into the pilot hole to keep the wallboard from falling behind the wall, and then make the final cut (Figure 16b).
4. Using your finger, pull out the piece of wallboard you have just cut.

Figure 16

Cutting along the outline (a), and using a finger to hold the cutout piece (b)

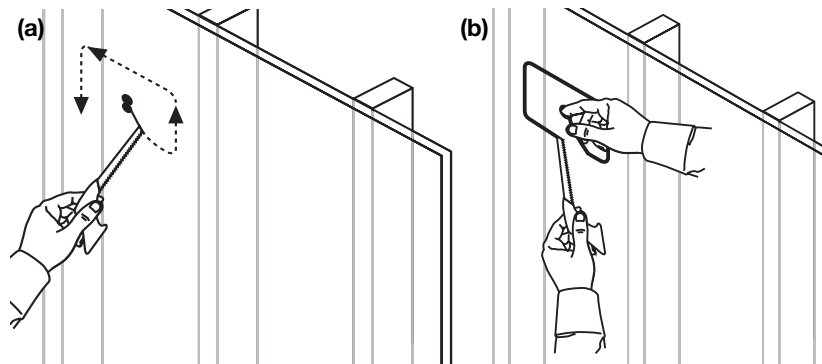

If you encounter insulation behind the wall

You can expect to find insulation in an exterior wall and sometimes in an interior wall. If the insulation found there is malleable, you can cut and remove some of it from both above and below the speaker hole to make room for the speaker. Other types of insulation will be difficult or possibly dangerous to handle.

⚠ CAUTION: Beware of hidden nails when reaching into the wall to remove insulation.

⚠ CAUTION: Wear gloves and protection for your mouth, nose, and eyes before handling insulation that contains fiberglass.

Reorienting or changing speaker frames***Reorienting the rectangular frame logo***

If you intend to mount a rectangular framed speaker upside-down due to a lack of space below the hole, you will need to reorient the logo before inserting it into the hole.

To do this, remove the frame from the speaker, rotate it 180°, and reattach the frame. There are four frame screws, labeled GRILLE, that hold the frame in place (See Figure 17 below and Figure 23 on page 18). Do not confuse them with the dogleg clamp screws that are labeled WALL.

Do not insert the speaker into the wall without a frame attached. The frame keeps the speaker from falling into the wall.

Figure 17

Replacing the rectangular speaker frame with the round frame

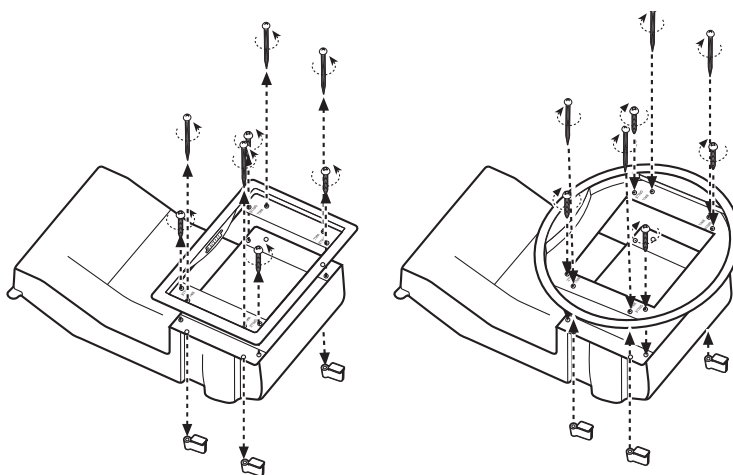
***Installing round speaker frames***

If you intend to use round speaker frames, install them now by removing the four screws that hold each rectangular frame and using them to secure the round frames (Figure 17). The logo is on the round speaker grille, which will be positioned later.

Insert and wire the speaker

✓ You need a **Phillips-head screwdriver** and **optional tape** to complete this step.

If your wall is not pre-wired, refer to “What to do when the room is not pre-wired” on page 24. When wire is within reach of the hole you have cut, follow the procedure below:

1. From inside the newly cut speaker hole, locate and pull out 14 in. (36 cm) or more of the pre-wired speaker cord (Figure 18 on page 16).

STEPS TO INSTALLING

Figure 18

Pulling the wire up and out, to the left (a) and securing it with tape (b).

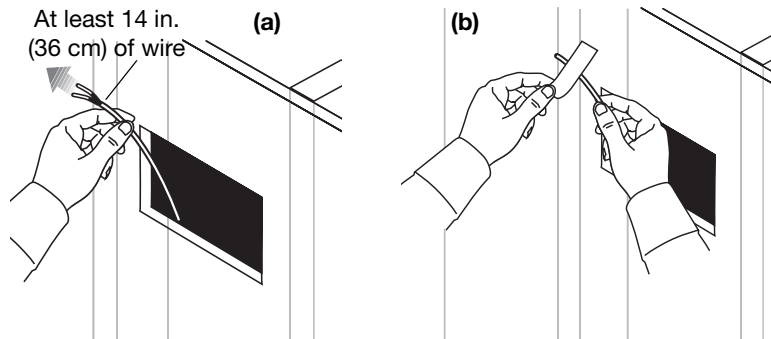

2. Use tape to temporarily affix the loose end of the wire above and to the left of the hole (Figure 18b). This keeps the wire out of the way until you have the speaker partially inserted in the wall and are ready to make the connections.

Insert the speaker into the opening

Before you follow the steps below, check to be sure none of the dogleg clamps (two on each side) are protruding from behind the frame of the speaker. If they are, press them back behind the frame so the speaker will fit into the hole.

Tip: Loosen the screw terminals on the upper left side of the speaker before inserting the speaker into the hole to save effort in making the connections.

1. Use both hands to support the speaker and angle it slightly, so it is diagonal to the hole. This allows clearance for the wall stops.
2. Insert the bottom of the enclosure through the hole and down part of the way – or up, depending on your clearance issues (Figure 19).

Figure 19

Partially inserting the rectangular-faced or round-faced speaker

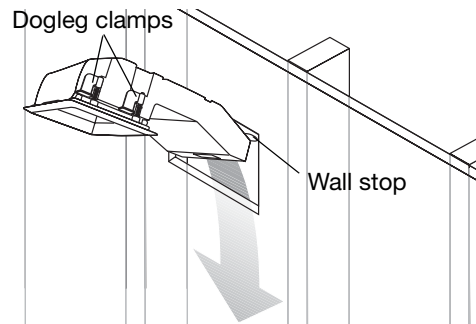

3. Leave the speaker in this partially inserted position, resting on the wall stops that prevent it from falling out (Figure 20). This allows ready access to the connection terminals on the upper left-hand side of the speaker.

Figure 20

Speaker held in place by wall stops

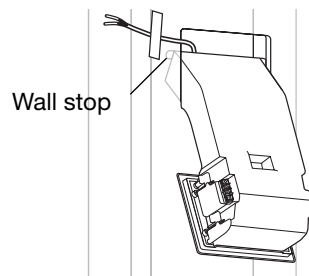

Make the speaker connections

- ✓ You need a **Phillips-head screwdriver** for this step.

Tip: Pay attention to maintaining the proper polarity (+ to + and – to –) with these connections. An error here will adversely affect speaker performance. Also be sure to tighten each screw securely, but not enough to cause undesirable compression of the wire.

1. If you have not done so earlier, loosen the screws on both terminals.
2. Insert the end of the marked wire (+) into the positive (+) terminal and tighten the screw (Figure 21).
3. Insert the end of the unmarked wire (–) into the negative (–) terminal. Tighten the screw.

⚠ **CAUTION:** Do not allow exposed wires to brush against each other, which could damage your components. Trim excess wire and reinsert as necessary.

Figure 21

Attaching wires to the terminals

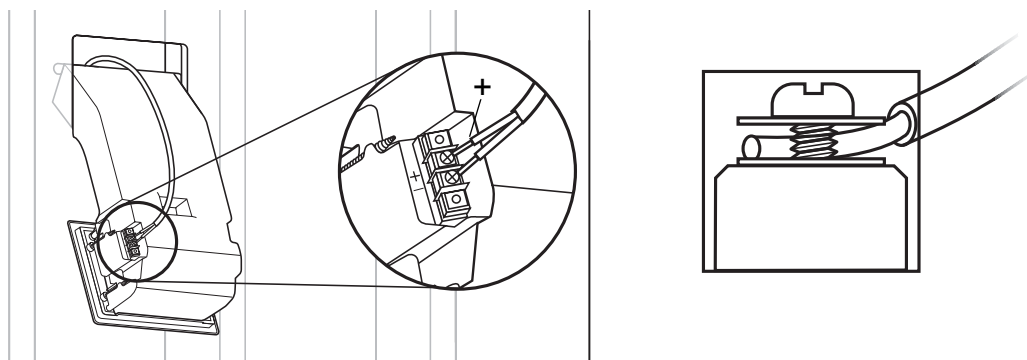

Test the speaker now

With the connections still within reach, now is a good time to test the speaker to make sure it functions properly before you secure it in the wall.

It may be preferable to begin installing the second speaker now, before you test either one. When you get the second speaker connected, you can test both speakers, and make sure they are both functioning fine before proceeding with the installation steps for each one.

⚠ **CAUTION:** If you are testing the first speaker before the other one is connected, make sure the wire to that first speaker is the only one connected to the receiver/amplifier. This prevents unattached speaker wires from making contact, which can damage the receiver/amplifier.

To test the speaker:

1. Turn on the receiver/amplifier and play a piece of music that is familiar to you.
2. Listen for clarity and accuracy of the performance from one speaker.
 - If you hear a problem, refer to “Troubleshooting” on page 27.
 - If the performance sounds fine, test the other speaker, or continue with the installation steps for this speaker.

Position the speaker all the way into the hole

1. When the connections are completed, push any excess wire into the hole behind the speaker (Figure 22 on page 18).

STEPS TO INSTALLING

2. Make sure the frame of the speaker is firmly screwed onto the face. The frame prevents the speaker from slipping all the way into the hole. Refer to Figure 17 on page 15 if you need to reverse the frame to orient the Bose logo on the rectangular speaker face.
3. Push the speaker into the hole until the face is straight and flush with the wall (Figure 22b).

Figure 22

Pushing excess wire behind the speaker (a) and Positioning the speaker all the way in the hole (b)

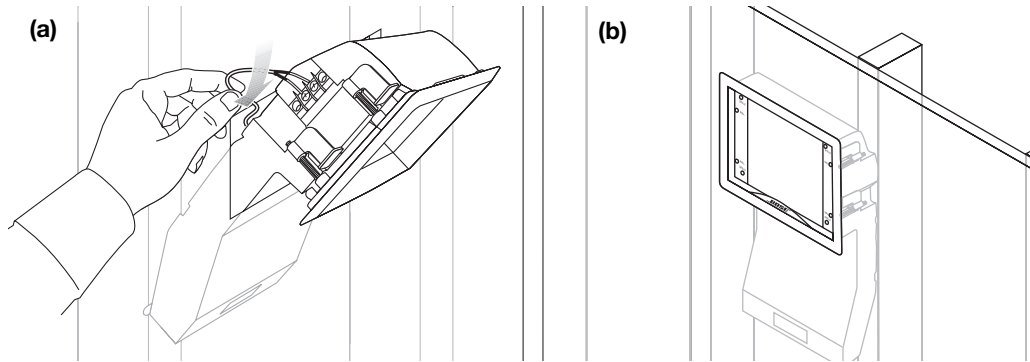
**Secure the speaker to the wall**

⚠ CAUTION: If you use a screw gun to tighten any screws, first select the gun's lowest torque setting (do not exceed 2-4 inch-pounds or 0.2-0.5 N-m of torque). If the screw does not seat properly, finish installing the screw at the next highest torque setting, or by hand.

When the speaker is positioned inside the hole with the face straight and flat against the wall, you are ready to tighten the dogleg clamp screws, labeled WALL, along the sides of the frame. The dogleg screws exert pressure from inside to hold the speaker firmly against the wall. Do not confuse the dogleg screws with those labeled GRILLE, which hold the frame.

⚠ CAUTION: Although they should be thoroughly screwed down, be sure not to overtighten the dogleg screws. Too much compression can crush the wallboard, making it crumble. This creates uneven surface support and can leave gaps between the speaker face and the wall.

1. Slightly tighten the four dogleg clamp screws (Figure 23) until each one begins to grip. This is caused by the clamps that swing out and press against the back of the wallboard.
2. With your fingers grasping the frame of the speaker, rock it slightly back and forth into position. Check for even seating of the face before you tighten the screws any further, and adjust the speaker if it needs to be straightened.

Figure 23

Tightening the dogleg clamp screws

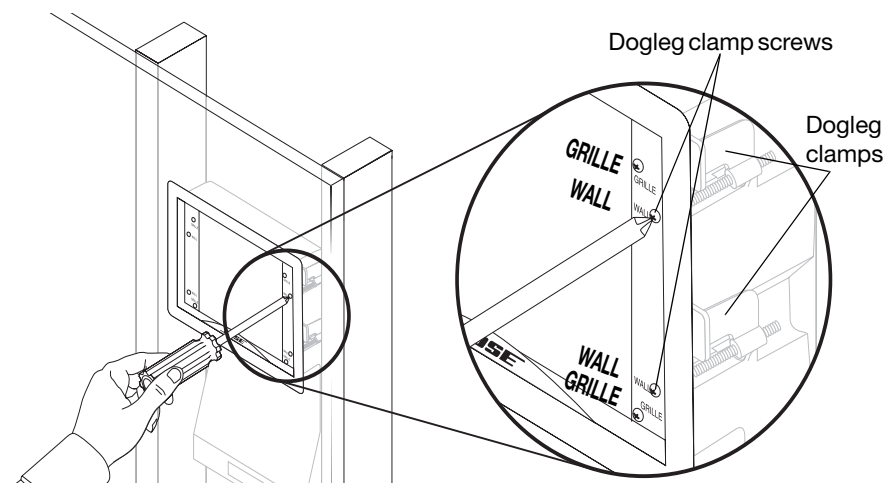

3. When the speaker is straight, tighten each screw.

Attaching rectangular grille frames

1. Line up the curved edge of the grille with the curve over the Bose® logo and press that edge into the speaker frame first (Figure 24).
2. Press the top of the grille firmly into place until you feel some resistance. When the grille lines up flush with the frame of the speaker, it is seated properly.

Figure 24

Snapping the grille into place

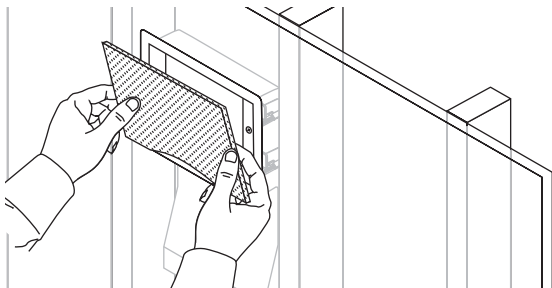

If the speaker looks crooked

When you step back from the wall, you may notice that the speaker is not straight. If so, it is easy to adjust the speaker slightly:

1. Remove the grille by inserting a thin-bladed tool between the speaker frame and the grille and carefully prying it out.
2. Slightly loosen each of the four dogleg clamp screws, labeled WALL.
3. Press on the sides of the speaker frame to shift it up or down into the proper position.
4. Stand back to make sure it is straight. Repeat step 3 if it is not.
5. Tighten all four dogleg clamp screws.
6. Reattach the grille to the front of the speaker.

Attaching round grilles

1. Line up the Bose logo in the desired position.
2. Tuck the Bose logo into the speaker frame first. See Figure 25.
3. Work your way to the top of the grille frame, using both hands to tuck the grille tabs into the frame. Be careful not to permanently bend the grille tabs.

🎵 **Note:** When the grille is inserted into the frame, the logo can not be re-positioned. Take care to insure it is in the desired position before pressing the entire grille into the frame.

Figure 25

Attaching round grilles

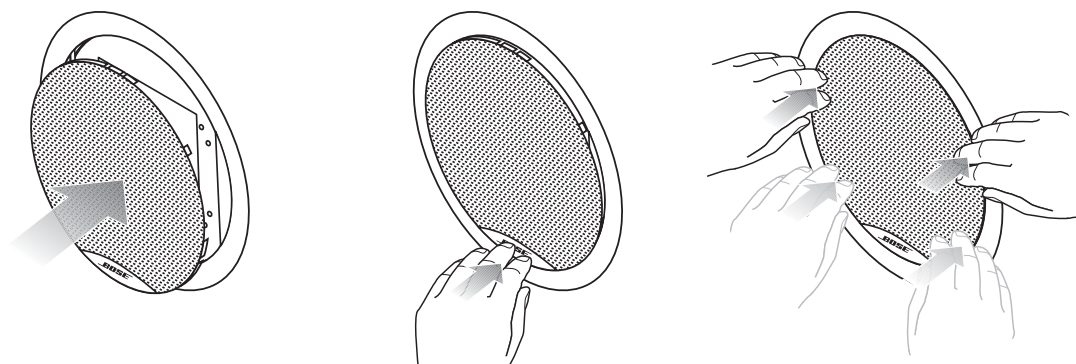

REFERENCE

Painting the speakers

The grille and frame of your Virtually Invisible® 191 speakers can be painted before or after the speaker is installed. This is optional, however, and Bose cannot be responsible for the quality of adhesion or finish of non-factory applied paints.

There are different techniques for painting the grille and painting the frame. Be sure to use paint that is appropriate to the technique you choose.

 **WARNING:** Follow all recommended safety procedures for the chemicals involved. This includes the proper use of eye protection, ventilation systems, respirators or filter masks, and fire safety equipment if flammable solvents are used.

Painting the grille

It is important to prevent paint from clogging the grille perforations, which can adversely affect performance. You can use a dry brush technique or spray paint the grille. However, do not use a paint roller:

- Remove the grille from the speaker if it has been installed.
- Before you begin to paint, clean the grille to remove possible contaminants. Even fingerprints can prevent uniform coverage.
- Check to be sure the paint is distributed evenly and covers the grille thoroughly. If not, you may need to paint the inside of the grille to fix the problem.
- When it is dry, protect the painted grille with a clean cloth or tissue paper until you attach it to the speaker.

Using a dry brush technique

Unthinned latex paint is appropriate for this method. Be sure to put down enough paper to cover your work area and allow for repeatedly blotting the brush.

1. Dip the tip of a clean, dry brush in the paint.
2. Stroke across the paper to reduce the amount of paint on the brush. When you can see individual bristle marks, the brush is ready to use on the grille.
3. Stroke lightly back and forth on the front of the grille, in a horizontal direction, until you need more paint.

Tip: If paint clogs any of the grille perforations, try angling your stroke to unclog it, or blow gently on the clog.

4. Repeat the above steps until the outside of the grille is completely covered.
5. Turn the grille 180° and repaint the entire surface using back-and-forth strokes again.

Using a spray technique

Latex or oil-based architectural paint requires thinning for use with a siphon-feed spray gun set for 30 psi (2.1 bar) and for application in a 3- to 5-inch (7.6-12.7 cm) fan pattern. The thinning formula depends on the type of paint you are using.

- Thin vinyl acrylic latex paint as follows:
To 6 parts of paint, add 3 parts of water and mix thoroughly. Add 1 part of denatured ethyl alcohol (which breaks down paint particles so they do not clog the grille) and mix again.
- For use of architectural or automotive paints:
This type of paint should be used by a professional with the right equipment and technique. This paint must also be thinned, using a solvent.
- Lacquer or enamel spray paint comes in an aerosol can and needs no further thinning.

1. To prevent dirt or dried paint particles from blowing back into the grille perforations, suspend the grille or place it on a wire screen.
2. Apply the paint to the grille surface at a 45° angle. Then rotate the grille by 180° and repaint it at 45°.

Figure 26

Angling and turning used to apply the paint twice

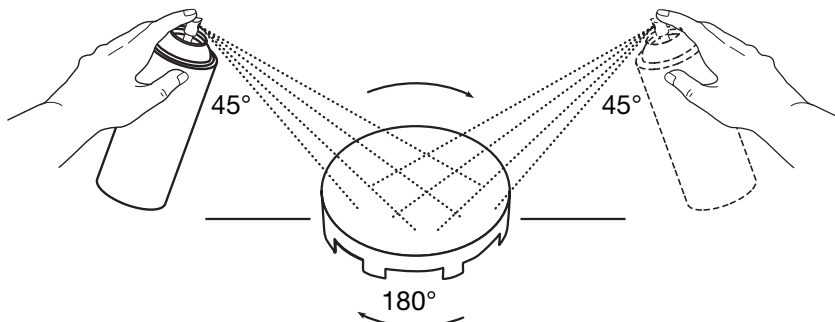

Tip: Piercing a perforation with a sharp implement to remove a clog can cosmetically damage the grille and is not recommended. If paint clogs any of the grille perforations, blow gently in that area to unclog it. If that does not work, immediately wash the grille with the appropriate solvent. Make sure the grille is thoroughly dry before repainting.

The paint may feel dry in a few minutes. However, if alcohol has been added, it may take several days to fully cure.

Painting the frame

Before you begin, protect the speaker cones by inserting the paint shield that came in the carton. Then you can use the same conventional spray or roller equipment used to paint the wall or ceiling.

You can use either latex or oil-based paints, which adhere to the speaker frame. However, both can be easily scratched through careless handling.

Be careful so the paint does not puddle or run. You may want to use a brush for spreading paint where needed.

Help for the beginning installer

This section provides information that may be helpful for the do-it-yourself installer.

Optional items that will assist you:

- Clothing appropriate for the job
- Gloves and protection for your mouth, nose, and eyes
- A drop cloth or other material to protect the area from debris
- A wire snake for running speaker cord behind wallboard
- A sturdy stool or ladder for installing speakers above your head

Accessories that can help

For installation in a drop ceiling (where tile is installed below the ceiling joists), Bose offers an optional Drop Ceiling Kit for two speakers. It protects the tile from bearing the weight of the speakers. Instructions are included with the kit.

For installation in new construction, Bose offers a Rough-in Kit for two speakers. It is designed for use after the studs are in place and before the wallboard is added to reserve a place for the speakers and indicate where the wallboard hole should be made. It also protects the wallboard by providing additional support for the dogleg clamps that secure the speaker to the wall. Instructions are included with the kit.

For more information or to order an accessory, contact your Bose dealer. Or, to contact Bose directly, refer to the address list included in the carton.

Using speaker cord

Before you cut any cord, estimate how much will be needed by measuring the distance from the receiver/amplifier to where each speaker will be installed. Make some allowance if the cord must go around corners or through walls, and leave at least 14 in. (36 cm) of cord to pull from the wall for making the connections easily. Allow extra length if you are installing ceiling speakers, so that you can make connections while standing on the floor.

Wire recommendations.

Gauge	Maximum Length
18 AWG (0.82 mm ²)	20 ft (6 m)
16 AWG (1.3 mm ²)	30 ft (9 m)
14 AWG (2.1 mm ²)	50 ft (15 m)

Preparing the speaker cord

Speaker cord consists of two insulated wires. The insulation around one wire is marked (striped, collared, or ribbed) to identify it as positive. The other wire is negative.

 **Note:** *It is sometimes difficult to distinguish wire markings. Inspect both wires carefully.*

1. Strip approximately $\frac{1}{2}$ inch (13 mm) of insulation from both wires. You will need a **wire cutter and wire stripper** for this work.
2. Twist the bare end of each wire so loose strands will not touch across terminals.

Be sure to connect each wire to the proper terminal, positive to positive (+) and negative to negative (-).

Before the wallboard goes up

There are some standard guidelines for working in unfinished construction.

- Begin this work after the studs and joists are in and the electrical wiring is completed.
- Snap a chalk line across the face of the studs or the bottom of the joists and move backward as you drill, so you can keep the last hole drilled in your line of sight.

- Never run speaker cord and electrical cable through the same hole or into the same junction box.
- If a short section of the cord must run parallel to nearby electrical cable, keeping that run to the absolute minimum will result in less interference.
- Use metal conduit or shielded speaker cord if the cord must run next to electrical cable for 10 ft. (3 m) or more.
- Use cable clamps or large wire staples to fasten the cord to a joist or stud wherever the cord runs more than 4½ ft. (1.4 m) from a hole.
- Use protective guard strips, raceways, or conduits to protect the cord from being stepped on or compressed in an attic or crawl space.

Installing in a pre-wired room

An installation is simplest when the room has been pre-wired during construction. In that case, the builder will have left speaker cord within easy reach of the intended speaker positions. In the ideal situation, after cutting the speaker hole you can simply reach inside to locate the length of cord the builder has installed.

If you are not sure that you have a pre-wired room, or do not know where the wiring is located, check the architectural drawings of your room or call the builder.

⚠ CAUTION: *It is important to know where the pre-wired cord is to prevent damaging it while drilling or cutting into the wall.*

Where the walls are finished

Here are some suggestions for how to make this job easier.

Look for ways to conceal cord outside the walls (See Figure 27):

- Along or behind baseboards
- Under carpets (using special flat speaker cord for under-the-rug speaker runs)
- Under doorjamb.

Figure 27

Running cord behind baseboards and a doorjamb

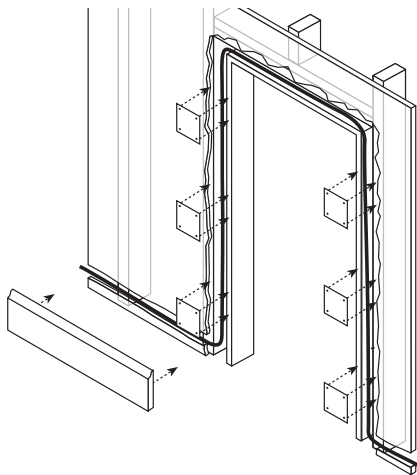

What to do when the room is not pre-wired

In this case, you will need to run speaker cord from the receiver or amplifier through the wall to the area you have chosen for installing the speakers. You will need to mount an open-backed junction box in the wall near the receiver or amplifier (Figure 28).

You also need to observe safe and practical standards:

▲ WARNING: Make sure the spot chosen is safe for drilling. Do not drill through surfaces that may have hazards, such as electrical wiring, conduits, or plumbing concealed behind them. Follow all other safety precautions.

▲ WARNING: Consult local building codes to inform yourself of the requirements in your area.

Figure 28

An open-backed junction box that allows cord to come through the wall near the receiver or amplifier

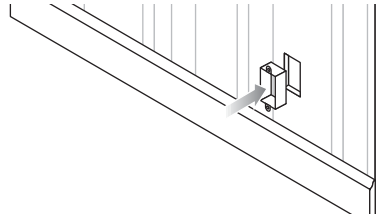

- Use a drill bit large enough for the cord you will pull through the holes.
- Use an auger bit, if possible, to make the work of drilling multiple holes less tiring.
- Do not drill through a load-bearing beam. Consult the building contractor if this is an issue.
- Keep cord 3 to 4 ft. (1 to 1.3 m) away from electrical cord, which can create a hum or buzz in the speakers. See Figure 29 on page 25.
- To avoid nails, drill holes in the center of each stud or joist.
- Use a nail plate to protect the cord if your only option is to notch a stud or joist.
- Line up holes as perfectly as possible to make pulling the cord through easier.
- Pull the cord so there are no sags but do not pull tight enough to create tension.

Find the easiest path for cord that must run behind the wallboard:

- Choose interior walls, which are less likely to have insulation packed behind the wallboard.
- Use an attic or basement run where possible, so you have easy access and can see where plumbing, electrical wires, and other impediments occur.
- In slab construction, consider using plenum-rated wire run through heating or air conditioning vents.

Figure 29

Techniques to use for running speaker cord through studs or joists

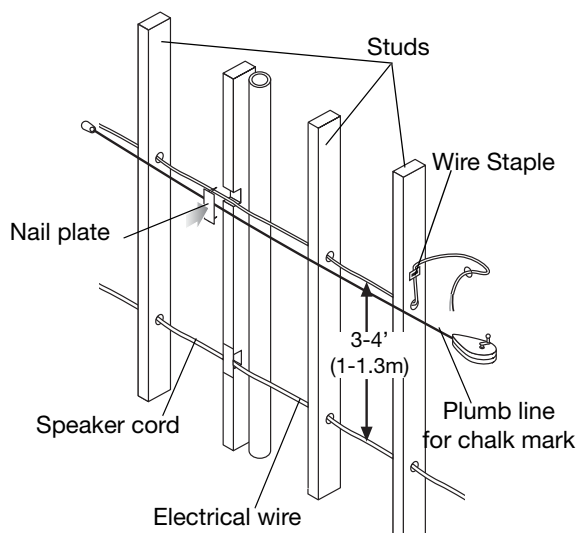

If you must route cord around a corner, you will need to cut out a rectangular piece of wallboard on either side of the joist at that corner. Use each regular-shaped cutout as the patch for the wall when you finish. By reaching through the cutout, you can notch the joist to make room for the cord and use nail plates to cover the cord in each notch (Figure 30).

Figure 30

Running cord around a corner with nail plates for protection (a) and cutout pieces as patches (b)

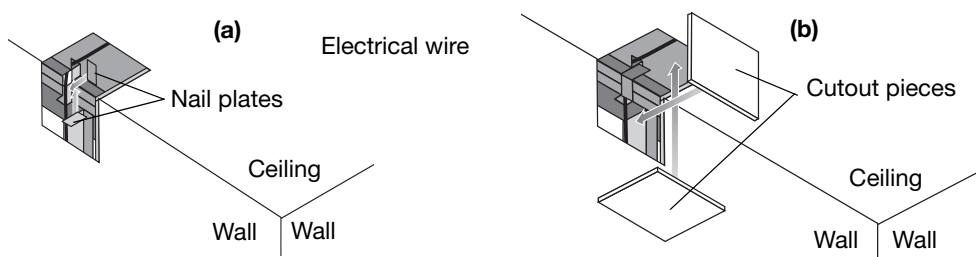

To patch the wall, reposition the cutout pieces and use joint tape and joint compound to hold them in place. When they are dry, sand and paint the area to match surrounding surfaces.

It is common to run cord from a speaker location in a wall or ceiling to the attic and through the wooden top plate that runs horizontally across the top of the vertical studs. You can then run the cord to the spot above the junction box near the receiver or amplifier. Drill through the top plate at that point and route the cord through the hole and down into the wall (Figure 31).

Figure 31

Running the cord up through the attic

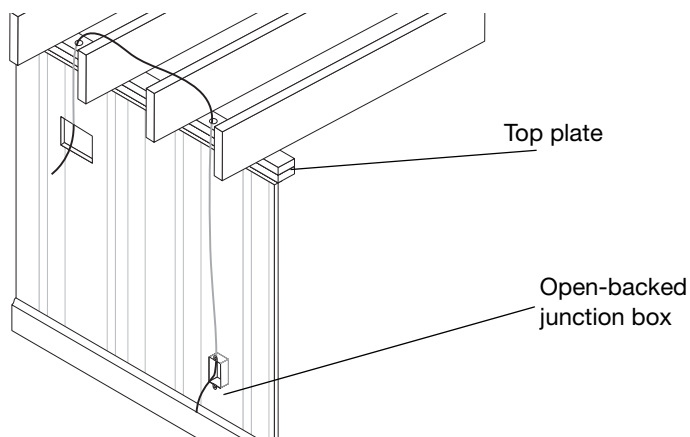

Installing in an exterior wall

If you choose to install these speakers in an exterior wall (abutting the outside of your house), you may encounter insulation behind the wallboard. This can complicate the installation, requiring you to trim and push malleable insulation out of the way. You will need to wear eye protection and gloves for working with fiberglass insulation.

 **WARNING:** *If you believe the insulation inside a wall may be composed of asbestos, do not cut into the wall. Choose a different location for the speakers instead.*

Insulation will also impede your use of a pilot hole to test the size of the space behind the wallboard. Doing such a test is recommended to make sure the space is large enough before cutting a speaker-sized hole.

Use special care in cutting through plaster and lath

For wall construction of plaster and lath, use special care to prevent plaster from cracking:

- After you have drawn an outline of the hole to cut, tape around the outline and use a sharp blade to make shallow cuts where the hole will be.
- Then, within the outline only, chip the plaster away until you expose the lath underneath.

Finally, cut through the lath very carefully. Using an electric sabre saw can be quick but risky. We recommend using a hand saw and proceeding cautiously to avoid damaging the surrounding plaster.

Special considerations in cold climate regions

With exterior wall installations in regions where outdoor temperatures dip below freezing for days at a time, using a humidifier can cause condensation to form inside the speakers. This can be more of a problem if the speakers are mounted upside down.

If you must mount in an exterior wall:

- Avoid installing the speakers upside down.
- Leave some of the insulation between the speakers and the exterior wall.
- Refrain from setting the humidifier on high, especially when outside temperatures are below freezing.

Troubleshooting

Neither speaker plays	<ul style="list-style-type: none"> • Check the settings on your receiver/amplifier. Refer to the owner's guide that came with it for instruction on settings. • If your Virtually Invisible® 191 speakers are the second pair of speakers connected to your receiver/amplifier, make sure the connections have been made to the "B" terminals and that the "B" speakers are selected to play.
The bass or treble is weak	<ul style="list-style-type: none"> • Check the tonal balance setting on your receiver/amplifier. • Check for consistent polarity of the connections (+ to + and – to –) to the receiver/amplifier and to the speaker. Review "Make the speaker connections" on page 17.
Only one speaker plays	<ul style="list-style-type: none"> • Check the balance control on your receiver/amplifier and make sure it is centered. • Check the wires connected to the speaker that does not play. Make sure the wires are in good condition and are firmly connected. Review "Make the speaker connections" on page 17.
Only one speaker still plays	<ul style="list-style-type: none"> • Trace the cord from the speaker in question to the receiver/amplifier. Disconnect the cord from the receiver/amplifier channel and reconnect it to a different receiver/amplifier channel. <ul style="list-style-type: none"> – If the performance is now fine, the problem lies in the original receiver/amplifier channel, the component source of the music, or the connections between the receiver/amplifier and the source. Check all of those to make sure they are performing properly. Reconnect the speaker to the correct channel of a functioning receiver/amplifier. – If the problem persists, its source is either the speaker wire or the speaker in question. Follow the next instruction. • Disconnect the cord from the speaker in question and reconnect it to the second speaker. <ul style="list-style-type: none"> – If the performance is now fine, the problem lies in the original speaker. Contact your authorized Bose® dealer, who will arrange for service. Or, to contact Bose directly, refer to the address list included in the carton. – If the problem persists, its source is the speaker wires. Follow the next instruction. • Before you take steps to replace and re-run the speaker wire, recheck all of the connections. Then repeat the procedure for pinning down the problem source, above.
Static or noise from one speaker	<ul style="list-style-type: none"> • Check the connections at the speaker and at the receiver/amplifier. Make sure the wires are in good condition, are firmly connected, and no wires are touching across terminals. Also check the connections from the receiver/amplifier to the component source of the music. <ul style="list-style-type: none"> – If the problem persists, follow the troubleshooting instructions for "Only one speaker still plays," above.

Customer service

For additional help in solving problems, contact your Bose dealer. Or, to contact Bose® Customer Service, refer to the address list included in the carton.

Warranty period

Bose Virtually Invisible® 191 speakers are covered by a limited 5-year transferable warranty. Details of coverage are on the warranty card that came with your speakers. Please fill out the information section, detach, and mail it to Bose.

Accessories

- Drop Ceiling Kit for two speakers
Protects the tile from bearing the weight of the speakers. Instructions included.
- Rough-in Kit for two speakers
Reserves a place for the speakers after the studs are in place and before the wallboard is added, and indicates where the wallboard hole should be made. Instructions included.

For further information or to order accessories, contact your Bose dealer. Or, to call Bose directly, refer to the address list included in the carton.

Technical information

Features

- Virtually Invisible® and Articulated Array® speaker design
- Proprietary enclosure technology
- Stereo Everywhere® speaker performance
- Paintable grille
- Syncom® computer tested

Compatibility

- Compatible with amplifiers or receivers rated 10-100W per channel/rated 4 to 8 ohms
- 50W IEC continuous power handling; rated 6 ohms

Driver complement

- Two (2) 2½" (6.4 cm) full-range drivers per speaker

Enclosure

- Ported and molded high-impact polystyrene
- White frame and grille

Dimensions

- Each speaker:
13¾"H x 7⅞"W x 3⅞"D (34.9 cm H x 19.9 cm W x 9.8 cm D)
- Wall or ceiling surface area required for each:
Rectangular-faced speaker – 8¾"W x 6"H (20.5 cm x 14 cm)
Round-faced speaker – 11¼" diameter (26 cm)

Weight

- 4.5 lb. (2.0 kg) each



BOSE[®]
Better sound through research[®]

©2005 Bose Corporation, The Mountain,
Framingham, MA 01701-9168 USA
288341 AM Rev.00 CCM-001615