



Installation, Operation & Maintenance Manual
Two Post
Surface Mounted Lift



MODEL QFP09

9,000 LBS. CAPACITY
2,250 LBS. PER ARM

200 Cabel Street, P.O. Box 3972 Louisville, Kentucky 40201-3972

Email: sales@qualitylifts.com

Web site: www.qualitylifts.com

Office 877-771-5438/ 502-625-0700 Fax 502-583-5488

**IMPORTANT: READ THIS MANUAL COMPLETELY BEFORE
INSTALLING or OPERATING LIFT**

GENERAL SPECIFICATIONS

See Figure 1	QFP09
A Column Height	120 7/8"
B Rise Height (<i>Screw Pads Highest Position</i>)	78 1/8"
C Screw Pad Height	4" to 5 7/8"
D Overall Width	137 1/2"
E Inside of Columns	109"
Drive Thru Clearance	98 3/16"
Ceiling Height Required	121 7/8"
* Maximum Capacity	9,000 lbs. (2250 lbs. Per Arm)
Lifting Time	60 Sec. (approximate for 2HP motor)
Motor	1HP/115v or 2HP/208-230v Single Phase, 60Hz Optional – 2HP, Three Phase, 50/60Hz, for 208 or 230 or 460

* Lift capacity ratings are based on loads equally distributed on all four arms.

** Lifting and lowering speeds may vary depending on the weight of the vehicle.

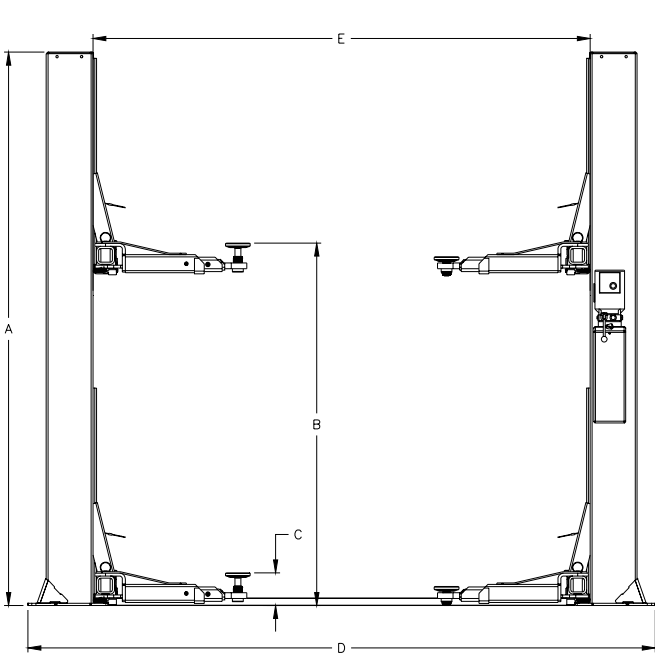

Fig 1a - General Specifications

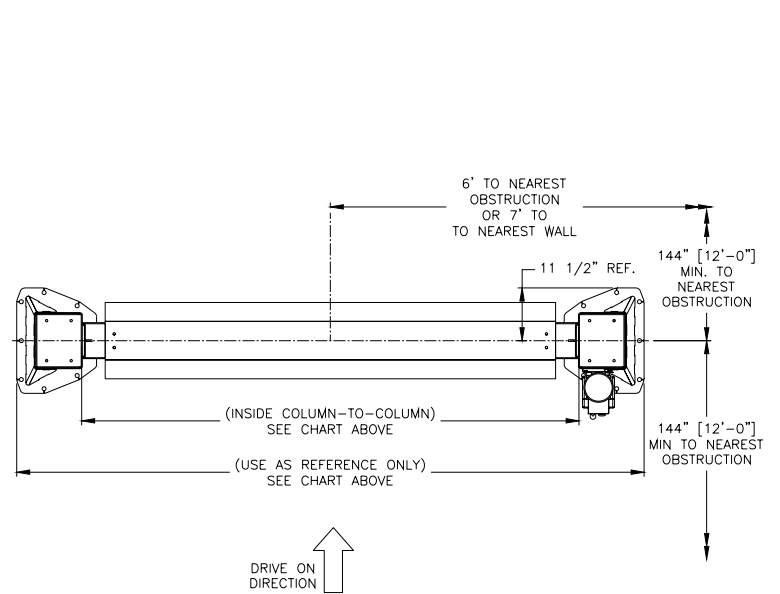

Fig1b - Service Bay Layout

VERTICAL CLEARANCE

Check the height of the area where the lift is to be installed. Clearance should be calculated based on the full raised height of the lift.



Failure by purchaser to provide adequate clearance could result in unsatisfactory lift performance, property damage, or personal injury.

FLOORING

Be certain you have the proper concrete floor to properly handle the loaded lift. Floor should be in generally good condition with no large cracks, spalling or deterioration.

Minimum requirements for concrete are 4 inches minimum depth, with steel reinforcement, 3500 psi, cured for 28 days per local commercial practice. Floor should be level within 3/8 inch over the installation area. No anchors should be installed within 8 inches of any crack, edge, or expansion joint. If these conditions cannot be met, a pad may be poured to accommodate the lift.

Check with local building inspectors and/or permits office for any special instructions or approvals required for your installation.



Failure by purchaser to provide the recommended mounting surface could result in unsatisfactory lift performance, property damage, or personal injury.

LOCATION

This lift has been evaluated for indoor use only with an operating ambient temp. range of 5 – 40°C (41– 104°F)

ELECTRICAL REQUIREMENTS

For lift installation and operation it is necessary to have a dedicated circuit with circuit breaker or time delay fuse. Refer to wiring diagram for circuit sizing.

SAFETY NOTICES AND DECALS

For your safety, and the safety of others, read and understand all of the safety notices and decals included here.

READ ENTIRE MANUAL BEFORE ASSEMBLING, INSTALLING, OPERATING, OR SERVICING THIS EQUIPMENT. PROPER MAINTENANCE AND INSPECTION IS NECESSARY FOR SAFE OPERATION. DO NOT OPERATE A DAMAGED LIFT.

Safety decals similar to those shown here are found on a properly installed lift. Be sure that all safety decals have been correctly installed on the Power Unit reservoir. Verify that all authorized operators know the location of these decals and fully understand their meaning. Replace worn, faded, or damaged decals promptly.



Do not attempt to raise a vehicle on the lift until the lift has been correctly installed and adjusted as described in this manual.

<p>SAFETY INSTRUCTIONS Read operating and safety manuals before using lift.</p>	<p>SAFETY INSTRUCTIONS Proper maintenance and inspection is necessary for safe operation.</p>	<p>If attachments, accessories or configuration modifying components that are located in the load path, affect operation of the lift, affect the lift electrical listing or affect intended vehicle accommodation are used on this lift and, if they are not certified for use on this lift, then the certification of this lift shall become null and void. Contact the participant for information pertaining to certified attachments, accessories or configuration modifying components.</p> <p>SAFETY INSTRUCTIONS</p> <p>www.autolift.org ©2007 by ALI, Inc. ALI/WLSIAO1</p>
<p>SAFETY INSTRUCTIONS Do not operate a damaged lift.</p>	<p>The messages and pictographs shown are generic in nature and are meant to generally represent hazards common to all automotive lifts regardless of specific style.</p> <p>Funding for the development and validation of these labels was provided by the Automotive Lift Institute, PO Box 33116 Indialantic, FL 32903</p> <p>They are protected by copyright. Set of labels may be obtained from ALI or its member companies.</p> <p>© 1992 by ALI, Inc. ALI/WLS1014</p>	

<p>CAUTION Lift to be used by trained operator only.</p>	<p>CAUTION Authorized personnel only in lift area.</p>	<p>WARNING Clear area if vehicle is in danger of falling.</p>	<p>WARNING Position vehicle with center of gravity midway between adapters.</p>
<p>CAUTION Use vehicle manufacturer's lift points.</p>	<p>CAUTION Always use safety stands when removing or installing heavy components.</p>	<p>WARNING Remain clear of lift when raising or lowering vehicle.</p>	<p>WARNING Avoid excessive rocking of vehicle while on lift.</p>
<p>CAUTION Use height extenders when necessary to ensure good contact.</p>	<p>CAUTION Auxiliary adapters may reduce load capacity.</p>	<p>WARNING Do not override self-closing lift controls.</p>	<p>WARNING Keep feet clear of lift while lowering.</p>
<p>The messages and pictographs shown are generic in nature and are meant to generally represent hazards common to all automotive lifts regardless of specific style.</p> <p>Funding for the development and validation of these labels was provided by the Automotive Lift Institute, PO Box 33116 Indialantic, FL 32903.</p> <p>They are protected by copyright. Set of labels may be obtained from ALI or its member companies.</p> <p>© 1992 by ALI, Inc. ALI/WLS1014</p>		<p>The messages and pictographs shown are generic in nature and are meant to generally represent hazards common to all automotive lifts regardless of specific style.</p> <p>Funding for the development and validation of these labels was provided by the Automotive Lift Institute, PO Box 33116 Indialantic, FL 32903.</p> <p>They are protected by copyright. Set of labels may be obtained from ALI or its member companies.</p> <p>© 1992 by ALI, Inc. ALI/WLS1014</p>	

RECEIVING

The shipment should be thoroughly inspected as soon as it is received. The signed bill of lading is acknowledgement by the carrier of receipt in good condition of shipment covered by our invoice.

If any of the goods called for on this bill of lading are shorted or damaged, do not accept them until the carrier makes a notation on the freight bill of the shorted or damaged goods. Do this for your own protection.

NOTIFY **Quality Lifts** AT ONCE if any hidden loss or damage is discovered after receipt.

IT IS DIFFICULT TO COLLECT FOR LOSS OR DAMAGE AFTER YOU HAVE GIVEN THE CARRIER A CLEAR RECEIPT.

File your claim with **Quality Lifts** promptly. Support your claim with copies of the bill of lading, freight bill, and photographs, if available.

Component Packing List

PART #	QTY/ LIFT	DESCRIPTION
B26075	1	Power Column Ass'y
B26076	1	Idler Column Ass'y
B26015	1	Drive Over Channel Weld
B26049	1	Drive Over Plate
B39071B	4	Arm Pack
B26027	1	Drive Over Extension Line
QFP09-001	1	HARDWARE BOX

ACCEPTED OILS – Do not use oils with detergents
Hydraulic fluid is not provided with the lift shipment
-10 wt. anti-foam, anti-rust hydraulic / biodegradable oil
-Dexron III ATF

INSTALLATION

IMPORTANT: Always wear safety glasses while installing lift.

TOOLS (MINIMUM REQUIRED)

- a. Tape measure, 16ft
- b. Chalk line
- c. 4ft level
- d. 10" adjustable wrench
- e. Open end wrenches 27mm or 1 1/16", 11/16"
- f. Needle nose pliers
- g. Hammer drill with 3/4" & 3/8" diameter carbide tipped bits
- h. 2lb hammer
- i. Torque wrench: 150 foot pounds minimum with 9/16" & 1 1/8" sockets
- j. 12 ft. Step ladder
- k. Anti-Seize lubricant (for arm pins and foot pad screw threads and stop rings)

LAYOUT

- 1) Layout the service bay according to the architect's plans or owners instructions (**see Fig 1b**). **Failure to install in this orientation can result in personal and property damage.** Be certain that the proper conditions exist, see page 3.
- 2) Erect both column assemblies. Align the notches in the column base and place the drive over channel in between. **Do not drill and anchor drive over channel at this time.**
- 3) When assembling top cap to the column, install hardware with nut and washers on the outside of the column.

COLUMN ANCHORING

- 4) The anchor bolts must be installed at least 8" from any crack, edge, or expansion joint.
- 5) Use a concrete hammer drill with a 3/4 inch carbide bit. Tip diameter should conform to ANSI Standard B94.12-1977 (.775 to .787). Do not use excessively worn bits or bits which have been incorrectly sharpened. A core bit may be necessary if an obstruction is encountered. **Never substitute with shorter anchor.**
- 6) Recheck "Inside of Columns" dimension, **Fig 1**. Drill the anchor holes using the base plate as a template. Drill through the floor if possible or to a depth of 4 inches minimum.

Complete steps 5 thru 8 for the five (5) exposed anchors around each column, then raise the carriages.

- 7) Vacuum dust from the hole for proper holding power.

- 8) Shim both columns to plumb using the shims provided as shown in **Fig 2**. DO NOT shim more than 1/2" at any given point. Use a level no less than 24" in length to plumb columns.
- 9) Assemble washer and nut to anchor with nut just below impact section of bolt. Drive anchor into hole until nut and washer contact base.

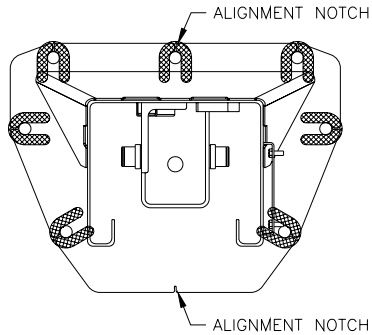

Fig 2 – Column Shimming

- 10) Tighten power column anchors and recheck column for plumb. Reshim if necessary. Torque to 150 foot pounds to set anchors.

POWER UNIT HYDRAULIC LINES

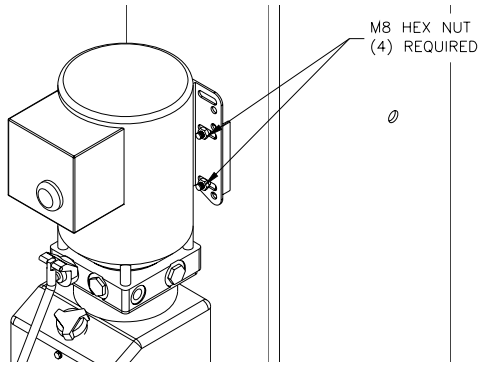

Fig 3 – Power Unit Mounting

IMPORTANT – To insure proper hose fitting seal without damage to the fitting follow this procedure for each hose connection: Screw flared fitting on finger tight. Rotate flared fitting 1 1/2 hex flats (90 deg.). Back the flared fitting off one full turn. Again tighten flared fitting finger tight, then rotate flared fitting 1 1/2 hex flats (90 deg.).

- 11) Mount Power Unit to power column as shown in **Fig 3**. The (4) mounting hardware nuts are pre-installed on power unit mounting bracket.
- 12) Thread 9/16-18 O-ring elbow (*in hardware box*) into power unit. Attach free end of power unit hose to elbow. See **Fig 4**. **CAUTION** do not damage rubber O-ring.

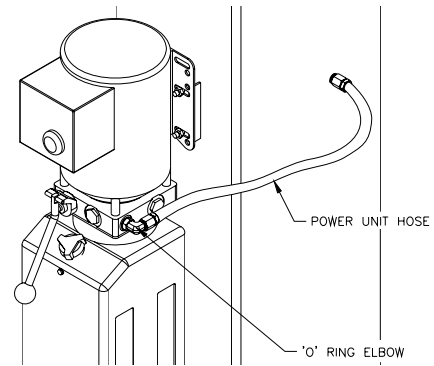

Fig 4-Power Unit Connection

SYNCHRONIZER CABLES & HYDRAULIC LINES

- 13) Raise each carriage into the first or second lock position.

Insure that the top of the hydraulic cylinder is still retained in the opening of the top plate of the carriage as shown in Fig 5.



Failure to follow previous step could result in personal injury.

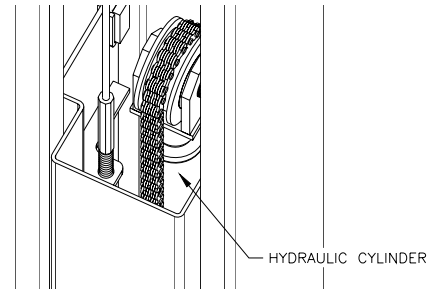

Fig 5-Cable Assembly

- 14) Position the provided hydraulic hose between the two columns in the drive over channel. Attach each end of the hose to the cylinders.
- 15) **Be Certain All Fittings and Connections are Tight. It is the installers responsibility to insure system is leak-free.** Fill the Power Unit with three gallons of clean 10wt anti-foam anti-rust hydraulic oil or Dexron III ATF. **Do Not Use Oils With Detergents.**
- 16) To install the cables around the bottom sheaves, remove the snap rings holding the sheave in place and disassemble, **Fig 6**.

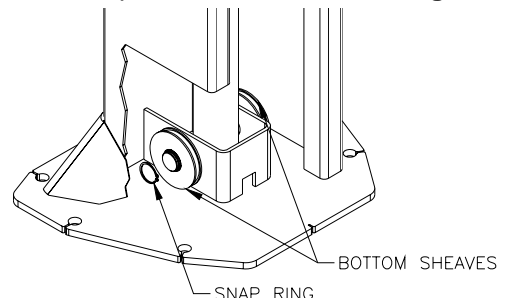

Fig 6-Lower Sheaves

- 17) Route the cable under the bottom sheave, along the drive over channel and under the bottom sheave of the opposite column, and reassemble.
- 18) Remove the cable trapping bolt assembly, **Fig 7**, on the top sheave. Route the cable up through the carriage and over the sheave. Reinstall the cable trapping bolt assembly once cable is routed properly.

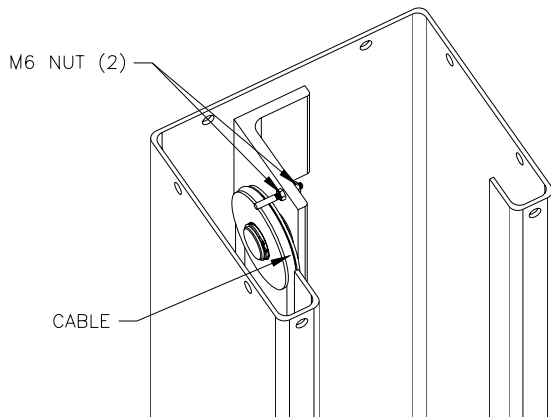

Fig 7-Upper Sheave

- 19) Attach the cable to the carriage with the provide nuts that came on the end of each cable,

Complete steps 15 thru 18 for the cables on each column.

- 20) Raise the carriages so the hydraulic cylinder is out of the way, and sent into the locks. Using a wrench, tighten the nut on the cable, **Fig 8** and then use the second nut as a jam nut once cables are adjusted properly.

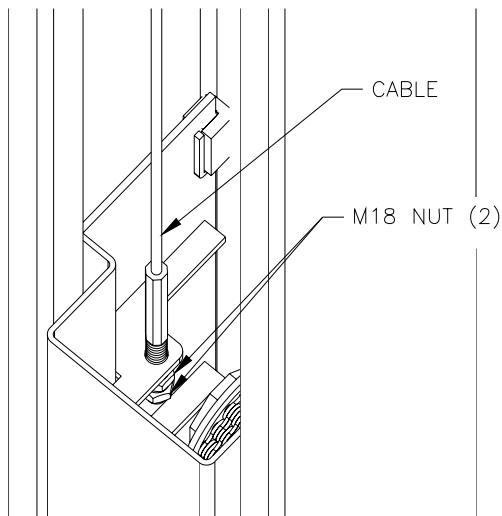

Fig 8-Cable Attachment

ARM INSTALLATION

- 21) Lubricate the arm pin or carriage arm pin hole with "anti-seize" and install the arms. Insure that the arm restraint gears engage and disengage properly. Arm restraints should disengage when lift is fully lowered. If any binding occurs, insure that the large gear mounted to the arm has been factory installed tight against the arm pin.
- 22) Extend the foot pad to both extents and apply "anti-seize" to the three retaining rings and where the double screw makes contact with the base of the foot pad.

ELECTRICAL

- 23) Have a certified electrician connect the power unit to a suitable electrical power source. The standard power unit is 208/230 volt 60 Hz single phase requiring a dedicated 25 amp double poll, double throw circuit breaker to operate lift at full capacity, **Fig 10**.

DRIVE OVER ANCHORING

- 24) Using the drive over channel as a template drill (4) Use a concrete hammer drill with a 3/8 inch carbide bit. Tip diameter should conform to ANSI Standard B94.12-1977 (.775 to .787). Do not use excessively worn bits or bits which have been incorrectly sharpened. A core bit may be necessary if an obstruction is encountered. **Never substitute with shorter anchor.**
- 25) Place the drive over plate over the drive over channel. Assemble washer and nut to anchor with nut just below impact section of bolt. Drive anchor into hole until nut and washer contact drive over plate.
- 26) Over tightening the 3/8 x 5" anchors will dimple the drive over plate. Torque anchors until top plate is secure.

COLUMN DECAL PLACEMENT

- 27) Center decal on idler column, opposite of the power unit.
- 28) Apply the decal 48" from the top of the base plate, **Fig 9**.

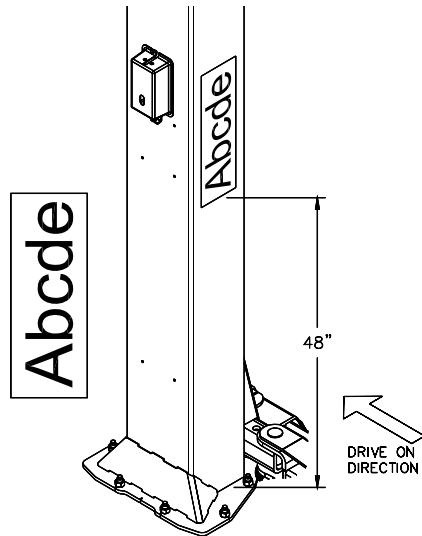

Fig 9 – Decal Placement

FINAL ADJUSTMENTS

HYDRAULICS

- 29) Pressure test hydraulic system. Energize power unit, raise lift to full rise and continue to run motor for additional 10 seconds. (NOTE: pressure relief will make a high pitch squeal sound for these 10 seconds.) Check hydraulic system for leaks.
- 30) Energize power unit again for 10 seconds. With a clean rag, wipe down both cylinder rods. (The cylinders are shipped with a small

amount of clear anti-corrosive lubricant that will be forced out through the wiper when the lift reaches full rise.) **If lubricant is not wiped clean from the cylinder rod, the cylinder will appear to be leaking.**

SYNCHRONIZING CABLES

- 31) Raise lift and insure carriages lower into same lock position.
- 32) Adjust synchronizing cables so the tension is equal in both cables and carriages are firmly sitting on locks.
- 33) Cycle lift to insure that latches operate simultaneously.

LOCK RELEASE CABLE

- 34) To lower the lift, raise the lift slightly off of a lock position and pull the lock release cables on each carriage.
- 35) Rise the lift fully making sure locks engage properly.

OWNER/OPERATOR CHECKLIST

- 36) Demonstrate the operation of the lift to the owner/operator and review correct and safe lifting procedures using the **Lifting It Right** booklet as a guide.
- 37) Complete the Installation Checklist/Warranty Validation questionnaire with the owner. Review the terms of the warranty registration card, and return the card and a copy of the questionnaires to:

Quality Lifts, Inc.
200 Cabel Street
Louisville, KY. 40206

Wiring Diagram

EACH LIFT SHOULD HAVE A DEDICATED CIRCUIT WITH A DOUBLE POLE (THREE POLE FOR 440-480V) BREAKER OR TIME DELAY FUSE SIZED ACCORDING TO THE FOLLOWING CHART

	1 ϕ 208-240V	3 ϕ 208V	3 ϕ 220-240V	3 ϕ 440-480V
2Hp	30amp	15amp	15amp	5amp

* WIRING MUST COMPLY WITH ALL LOCAL ELECTRICAL CODES *

FOR SINGLE PHASE

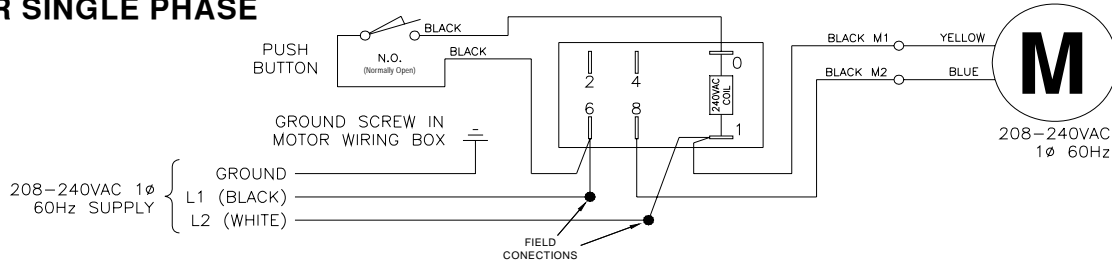

FOR THREE PHASE

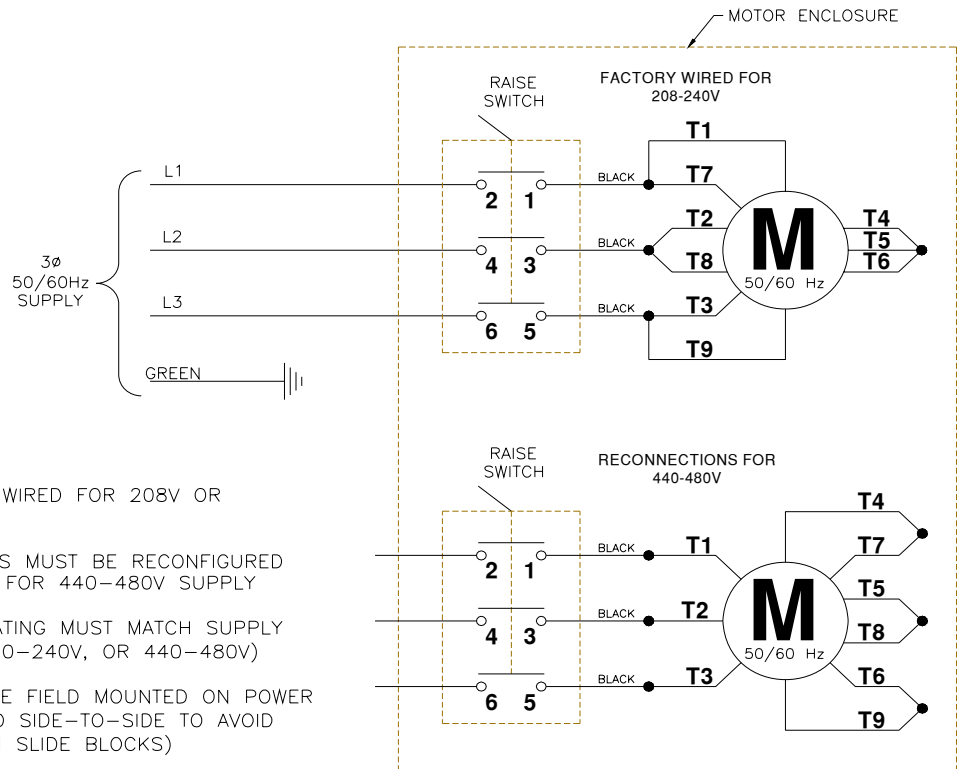

NOTES:

- 1) MOTOR IS FACTORY WIRED FOR 208V OR 220-240V SUPPLY
- 2) MOTOR CONNECTIONS MUST BE RECONFIGURED PER THIS DIAGRAM FOR 440-480V SUPPLY
- 3) CONTACTOR COIL RATING MUST MATCH SUPPLY VOLTAGE (208V, 220-240V, OR 440-480V)
- 4) CONTACTOR MUST BE FIELD MOUNTED ON POWER COLUMN (CENTERED SIDE-TO-SIDE TO AVOID INTERFERENCE WITH SLIDE BLOCKS)
- 5) MOTOR ROTATION IS COUNTER CLOCKWISE FROM TOP OF MOTOR

Fig 10 – Electrical Wiring Diagram

OPERATION PROCEDURE

SAFETY NOTICES AND DECALS

This product is furnished with graphic safety warning labels, which are reproduced on page 3 of these instructions. Do not remove or deface these warning labels, or allow them to be removed or defaced. For your safety, and the safety of others, read and understand all of the safety notices and decals included.

OWNER/EMPLOYER RESPONSIBILITIES

This lift has been designed and constructed according to ANSI/ALI ALCTV-2006 standard. The standard applies to lift manufactures, as well as to owners and employers. The owner/employer's responsibilities as prescribed by ANSI/ALI ALOIM-2000, are summarized below. For exact wording refer to the actual standard provided with this manual in the literature pack.

The Owner/Employer shall insure that lift operators are qualified and that they are trained in the safe use and operation of the lift using the manufacturer's operating instructions; ALI/SM 93 -1, ALI Lifting it Right safety manual; ALI/ST-90 ALI Safety Tips card; ANSI/ALI ALOIM-2000, American National Standard for Automotive Lifts-Safety Requirements for Operation, Inspection and Maintenance; ALI/WL Series, ALI Uniform Warning Label Decals/Placards; and in case of frame engaging lifts, ALI/LP-GUIDE, Vehicle Lifting Points/Quick Reference Guide for Frame Engaging Lifts.

The Owner/Employer shall establish procedures to periodically inspect the lift in accordance with the lift manufacturer's instructions or ANSI/ALI ALOIM-2000, American National Standard for Automotive Lifts-Safety Requirements for Operation, Inspection and Maintenance; and the employer shall insure that the lift inspectors are qualified and that they are adequately trained in the inspection of the lift.

The Owner/Employer shall establish procedures to periodically maintain the lift in accordance with the lift manufacturer's instructions or ANSI/ALIOIM-2000, American National Standard for Automotive Lifts-Safety Requirements for Operation, Inspection and Maintenance; and the employer shall insure that the lift maintenance personnel are qualified and that they are adequately trained in the maintenance of the lift.

The Owner/Employer shall maintain the periodic inspection and maintenance records recommended by the manufacturer or ANSI/ALI ALOIM-2000, American National Standard for Automotive Lifts-Safety Requirements for Operation, Inspection and Maintenance.

The Owner/Employer shall display the lift manufacturer's operating instructions; ALI/SM 93 -1, ALI Lifting it Right safety manual; ALI/ST-

90 ALI Safety Tips card; ANSI/ALI ALOIM-2000, American National Standard for Automotive Lifts-Safety Requirements for Operation, Inspection and Maintenance; and in the case of frame engaging lift, ALI/LP-GUIDE, Vehicle Lifting Points/Quick Reference Guide for Frame Engaging Lifts; in a conspicuous location in the lift area convenient to the operator.

IMPORTANT SAFETY INSTRUCTIONS

When using your garage equipment, basic safety precautions should always be followed, including the following:

1. Read all instructions.
2. Care must be taken as burns can occur from touching hot parts.
3. To reduce the risk of fire, do not operate equipment in the vicinity of open containers of flammable liquids (gasoline).
4. Keep hair, loose clothing, fingers, and all parts of body away from moving parts.
5. Use only as described in this manual. Use only manufacturer's recommended attachments.
6. ALWAYS WEAR SAFETY GLASSES. Everyday eyeglasses only have impact resistant lenses, they are not safety glasses.

SAVE THESE INSTRUCTIONS

LIFTING A VEHICLE

- 1) Insure that the lifting arms are parked, out to full drive thru position.
- 2) Center the vehicle between the columns in the service bay and position the vehicle's center of gravity midpoint between the columns. NOTE: the center of gravity is based on the weight distribution and is not the same as the center point of the vehicle.

DO NOT EXCEED 2250 POUNDS PER ARM.

DO NOT ATTEMPT TO LIFT THE VEHICLE WITH ONLY TWO ARMS, AS THIS WILL VOID THE WARRANTY

INSURE THAT THE HIGHEST POINT ON THE VEHICLE WILL CONTACT THE OVERHEAD LIMIT SWITCH BAR.

DO NOT PLACE THE VEHICLE IN THE SERVICE BAY BACKWARDS.

WHEN LIFTING FRAMED VEHICLES IT IS SUGGESTED THAT YOU USE THE FRAME ENGAGING ADAPTERS ((10318) OPTIONAL). FAILURE TO DO SO ON SLICK (UNDERCOATED) AND/OR PITCHED FRAME RAILS MAY RESULT IN PERSONAL OR PROPERTY DAMAGE.

REFER TO THE VEHICLE MANUFACTURERS SERVICE MANUAL, TECHNICAL BULLETINS, "VEHICLE LIFTING POINTS GUIDE" (ALI/LP-GUIDE) OR OTHER PUBLICATIONS TO LOCATE THE RECOMMENDED LIFTING POINTS.

- 3) Position the arms and adapters so all four pads contact the vehicle simultaneously.

The vehicle should remain level during lifting.

- 4) Raise the lift until all four wheels are off the ground. Test the stability of the vehicle by attempting to rock the vehicle. Check adapters for secure contact with vehicle lift points. If the vehicle seems unstable, lower the lift and readjust the arms. If the vehicle is stable, raise the vehicle to a height a few inches above the desired working height.
- 5) Lower the vehicle until the safety latches on both columns engage. The vehicle should remain level when both latches are engaged. If one side engages and the other continues to descend, stop lowering the vehicle, raise it several inches, and try again to engage both latches.

Always lower lift into locks before entering the area beneath the vehicle.

Always use safety stands when removing or installing heavy components.

LOWERING A VEHICLE

- 1) Insure that the area under the vehicle is clear of personnel and tools.
- 2) Raise the vehicle until both latches are free.
- 3) Disengage the latches by pulling both the lock release latches on both carriages.

- 4) Lower the vehicle by depressing the lowering valve handle.

- 5) Continue to lower the vehicle until the carriages stop against the base plate. Retract the extension arms, and park them.

MAINTENANCE

To avoid personal injury, permit only qualified personnel to perform maintenance on this equipment. Maintenance personnel should follow lockout/tagout instructions per ANSI Z244.1.

The following maintenance points are suggested as the basis of a routine maintenance program. The actual maintenance program should be tailored to the installation. See ANSI/ALI ALOIM booklet for periodic inspection checklist and maintenance log sheet.

- If lift stops short of full rise or chatters, check fluid level and bleed both cylinders per Installation Instructions.
- Replace all Safety, Warning or Caution Labels if missing or damaged (**See Installation instructions page 3.**)

Daily

- Keep lift components clean.
- Check for loose or broken parts.
- Check hydraulic system for fluid leaks.
- Check adapters for damage or excessive wear. Replace as required with genuine Challenger Lifts parts.
- Check lock release activation. When properly adjusted, the idler column lock should rest firmly against the back of the column when engaged and against the spring mount tab when disengaged.

Weekly

- Check synchronizer cables and sheaves for wear. Replace as required with genuine Challenger Lifts parts.
- Check lock release cable adjustment per Installation Instructions step 19.
- Check synchronizer cable tension per Installation Instructions. Adjust if necessary.

Monthly

- Torque concrete anchor bolts to 80 ft-lbs.
- Lubricate carriage slide tracks with heavy viscous grease. (Grease all (4) corners of both columns.)
- Visually inspect concrete floor for cracks and/or spalls within 12" of base plate

If any problems are encountered, contact your local service representative.

PARTS BREAKDOWN

Fig A. Column & Overhead

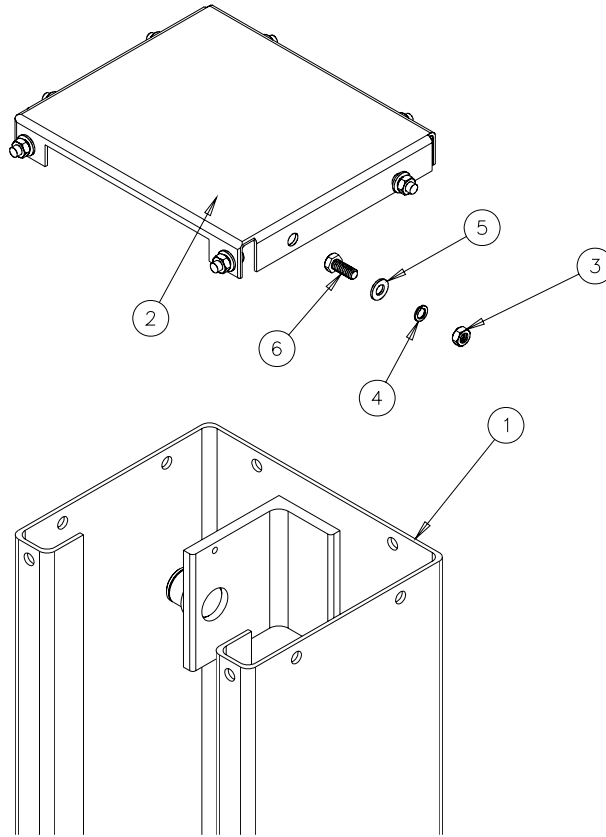

ITEM #	PART #	QTY/LIFT	DESCRIPTION
1	B26075	1	POWER COLUMN WELD
	B26076	1	IDLER COLUMN WELD
2	B26011	2	TOP CAP
3	B31038	16	M10 NUT
4	B31037	16	M10 SPLIT LOCKWASHER
5	B31036	16	M10 FLAT WASHER
6	B1068	16	M10x25mm HEX FLANGE HEAD BOLT

Replace all worn or broken parts with genuine **Quality Lifts Inc.** parts.
 Contact your local Quality Lifts Parts Distributor for pricing and availability.
 (Call Quality Lifts Inc. (502) 625-0700 for the Parts Distributor in your area)

PARTS BREAKDOWN (continued)

Fig B. Lock

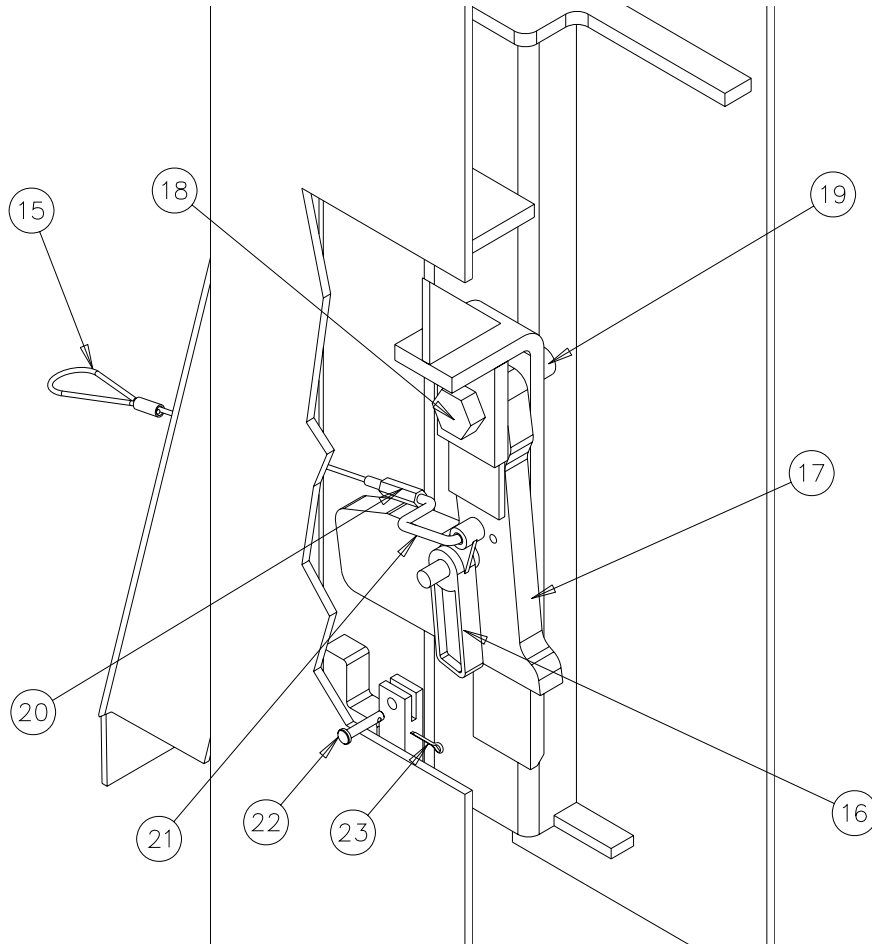

ITEM #	PART #	QTY/LIFT	DESCRIPTION
15	B31150	2	SOFT LATCH RELEASE
16	B31262	2	TRIGGER GRAVITY LATCH
17	B31261	2	GRAVITY LATCH
18	B31081	2	M20x70mm Lg. HEX HEAD CAP SCREW
19	B31082	2	M20 LOCK NUT
20	B31149	2	M6 COUPLING NUT
21	B31151	2	HOOK-LOCK RELEASE HANDLE
22	31079-01	4	CLEVIS PIN
23	31079-02	4	COTTER PIN, Ø2.5mm X 20mm

Replace all worn or broken parts with genuine **Quality Lifts Inc.** parts.
Contact your local Quality Lifts Parts Distributor for pricing and availability.
(Call Quality Lifts Inc. (502) 625-0700 for the Parts Distributor in your area)

Model QFP09
Installation, Operation and Maintenance

PARTS BREAKDOWN (continued)

Fig C. Hydraulics

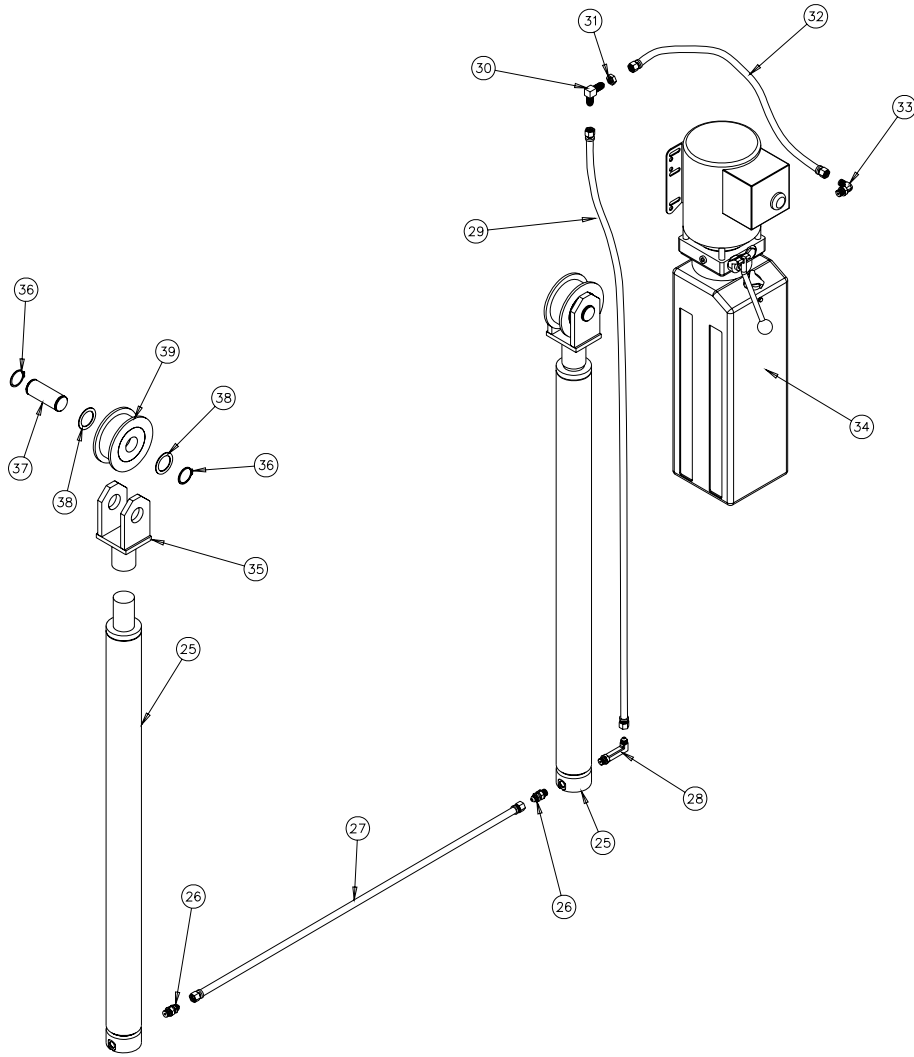

ITEM #	PART #	QTY/LIFT	DESCRIPTION
25	QY31265	2	36" STROKE HYD. CYLINDER
26	B31116	2	9/16-18 O-RING UNION
27	B26027	1	DRIVE OVER EXTENSION LINE
28	JSS3-19	2	9/16-18 ELBOW 90°
29	B31090	1	CYLINDER HYD. LINE
30	B26000-01	2	9/16-18 ELBOW 90°
31	B26000-02	2	9/16-18 NUT
32	JSJ5-17CH	1	HYD. HOSE ASSEMBLY (P/U – 22")
33	16167	1	HYD ELBOW, 9/16 O-RING MALE TO #6 MALE FLARE
34	31368-19	(1)	POWER UNIT 1Ph, 60Hz, 208-230V
	AB-7816-1	(1)	POWER UNIT 1Ph, 60Hz, 115v
	31355-19	(1)	POWER UNIT 3Ph, 60Hz, 208-460V
35	B31094	2	CYLINDER ROD END WELDMENT
36	B31021	10	35mm RETAINING RING
37	B31093	2	Ø35mm PIN
38	B31092	4	36mm x 50mm x 1.5mm WASHER
39	B31095	2	ROLLER ASSEMBLY

Replace all worn or broken parts with genuine **Quality Lifts Inc.** parts.
Contact your local Quality Lifts Parts Distributor for pricing and availability.
(Call Quality Lifts Inc. (502) 625-0700 for the Parts Distributor in your area)

Model QFP09
Installation, Operation and Maintenance

PARTS BREAKDOWN (continued)

Fig D. Synchronizer

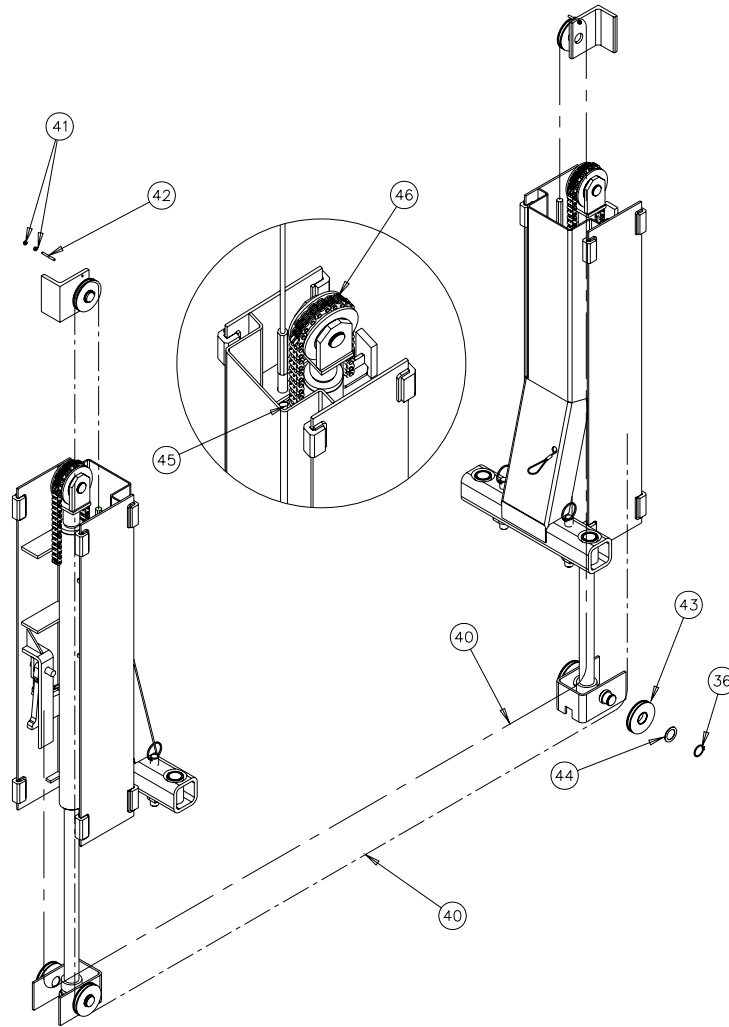

ITEM #	PART #	QTY/LIFT	DESCRIPTION
40	B26052	2	POWER / IDLER CABLE
41	B26044-03	4	M6 HEX NUT
42	B26044-02	2	CABLE TRAPPING THREADED ROD
43	B26008	6	CABLE SHEAVE
44	B26008-02	6	M35 WASHER
45	JSJ5-04-02	8	M18 HEX NUT
46	B31079	2	73P DRIVE CHAIN

Replace all worn or broken parts with genuine **Quality Lifts Inc.** parts.
Contact your local Quality Lifts Parts Distributor for pricing and availability.
(Call Quality Lifts Inc. (502) 625-0700 for the Parts Distributor in your area)

Model QFP09
Installation, Operation and Maintenance

PARTS BREAKDOWN (continued)

Fig E. Carriage & Arms

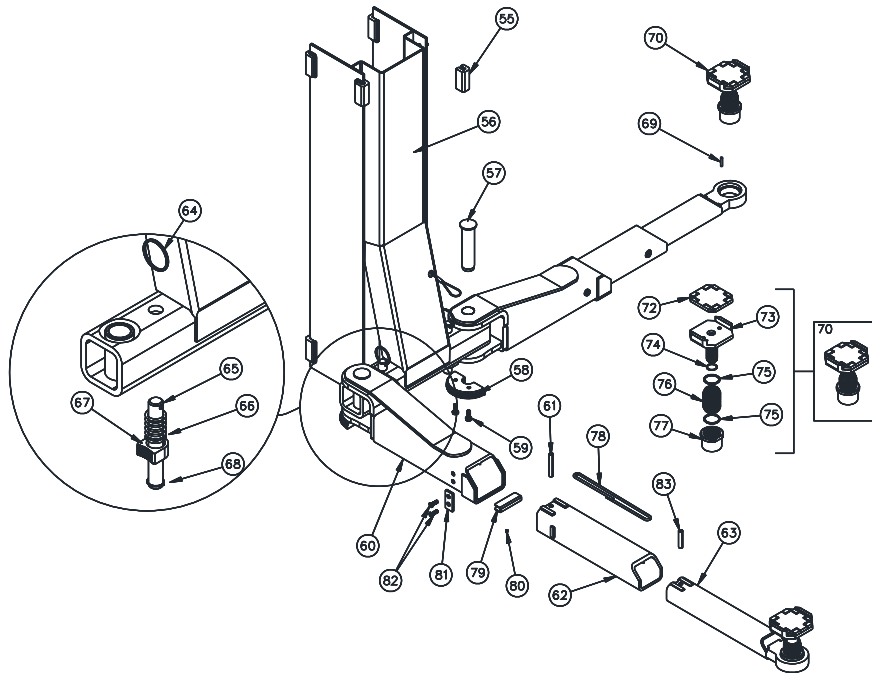

ITEM #	PART #	QTY/LIFT	DESCRIPTION
55	B31023	16	SLIDE BLOCK
56	B26024	2	CARRIAGE WELD
57	A1078	4	ARM PIN
58	A1070TC	4	INNER GEAR (ARM RESTRAINT)
59	B1068	8	M8x1.25 x 16 Flat Socket Head Screw
60	B39072B	4	FEMALE ARM WELD
61	B2202-02	4	ROLL PIN, 12mm DIA x 80mm Lg
62	B39071-01-00C	4	INTERMEDIATE ARM WELD
63	B39071-02-00A	4	MALE ARM WELD
64	A1075	4	PULL RING
65	A1073C	4	SHAFT
66	B31109	4	COMPRESSION SPRING (RESTRAINT SHAFT)
67	A1072TC	4	OUTER GEAR
68	B36014	4	RETAINING RING
69	B2211	4	ROLL PIN, 6mm DIA x 30mm Lg
70	B2270	4	FOOT PAD ASSEMBLY (items 72-77)
72	A1104-H	4	RUBBER INSERT
73	A1101-1H	4	FOOT PAD WELD
74	B17256	4	2 x 30mm ROUND WIRE RETAINING RING
75	B17257	8	3 x 45mm ROUND WIRE RETAINING RING
76	B2261	4	THREADED SLEEVE
77	B17276-1	4	THREADED INSERT
78	39073	4	STOP LOOP
79	17425	4	FEMALE ARM SHIM
80	17426	4	¼-20 x ¼" Lg. SELF LOCKING SET SCREW
81	CS1020-04	4	STOP BLOCK
82	17350	8	M8 x 10mm Lg. FLAT HEAD BOLT
83	B2202-01	4	ROLL PIN, 12mm DIA x 60mm Lg
	B39071D	4	ARM ASSEMBLY ITEMS: 58, 59, 60, 61, 63, 70, 78, 79, 80, 81, 82, 83

Replace all worn or broken parts with genuine **Quality Lifts Inc.** parts.
Contact your local Quality Lifts Parts Distributor for pricing and availability.
(Call Quality Lifts Inc. (502) 625-0700 for the Parts Distributor in your area)

PARTS BREAKDOWN (continued)

Fig F. Drive Over Assembly

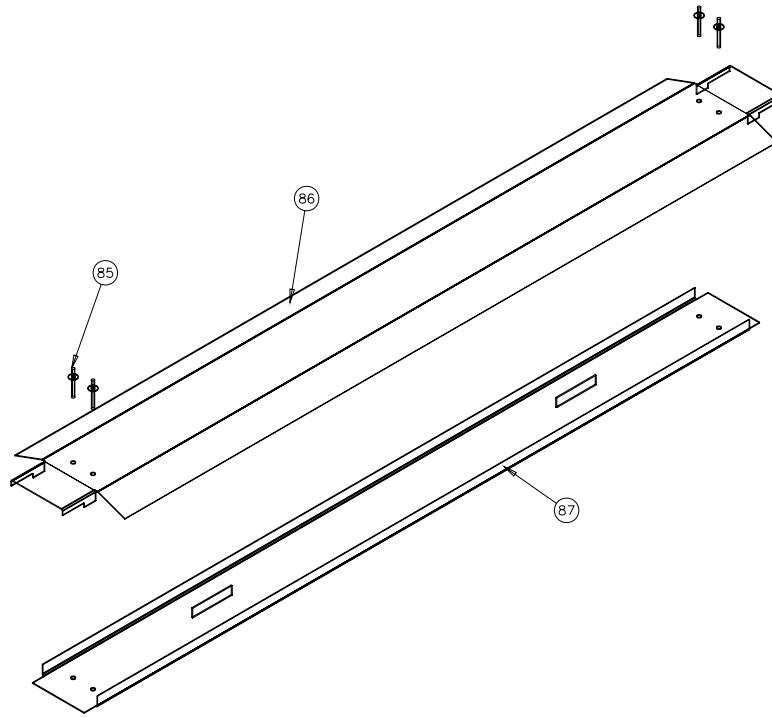

ITEM #	PART #	QTY/LIFT	DESCRIPTION
85	26028	4	3/8 x 5" ANCHOR BOLTS
86	B26049	1	DRIVE OVER PLATE
87	B26015	1	DRIVE OVER CHANNEL

Replace all worn or broken parts with genuine **Quality Lifts Inc.** parts.
Contact your local Quality Lifts Parts Distributor for pricing and availability.
(Call Quality Lifts Inc. (502) 625-0700 for the Parts Distributor in your area)

WARRANTY REGISTRATION FORM

SERIAL # _____ INV. DATE: _____

DISTRIBUTED BY: _____

ADDRESS: _____

CITY: _____ STATE: _____ ZIP: _____

CUSTOMER INFORMATION

COMPANY NAME: _____

CONTACT: _____

PHONE NUMBER: _____

ADDRESS: _____

CITY: _____ STATE: _____ ZIP: _____

Please remit form to:

**Quality Lifts
P.O. Box 3972
Louisville, KY 40201
(877) 771-5438 office
(502) 583-5488 fax**

This form must be received by Quality lifts for warranty to become effective!