



Internal Use Only

North/Latin America  
Europe/Africa  
Asia/Oceania

<http://aic.lgservice.com>  
<http://eic.lgservice.com>  
<http://biz.lgservice.com>

# PLASMA TV

# SERVICE MANUAL

CHASSIS : PB11K

**MODEL : 50PT490B**

**50PT490B-SA**

**50PT490B**

**50PT490B-SD**

## CAUTION

BEFORE SERVICING THE CHASSIS,  
READ THE SAFETY PRECAUTIONS IN THIS MANUAL.

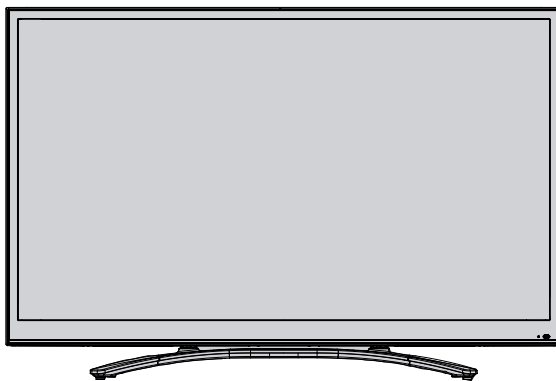

P/NO : MFL66986913 (1106-REV00)

Printed in Korea

# CONTENTS

<b>CONTENTS .....</b>	<b>2</b>
<b>SAFETY PRECAUTIONS .....</b>	<b>3</b>
<b>SPECIFICATION .....</b>	<b>4</b>
<b>ADJUSTMENT INSTRUCTION .....</b>	<b>6</b>
<b>BLOCK DIAGRAM .....</b>	<b>13</b>
<b>EXPLODED VIEW .....</b>	<b>14</b>
<b>SCHEMATIC CIRCUIT DIAGRAM .....</b>	<b></b>

# SAFETY PRECAUTIONS

## IMPORTANT SAFETY NOTICE

Many electrical and mechanical parts in this chassis have special safety-related characteristics. These parts are identified by  $\triangle$  in the Schematic Diagram and Exploded View.

It is essential that these special safety parts should be replaced with the same components as recommended in this manual to prevent X-RADIATION, Shock, Fire, or other Hazards.

Do not modify the original design without permission of manufacturer.

### General Guidance

An **isolation Transformer should always be used** during the servicing of a receiver whose chassis is not isolated from the AC power line. Use a transformer of adequate power rating as this protects the technician from accidents resulting in personal injury from electrical shocks.

It will also protect the receiver and its components from being damaged by accidental shorts of the circuitry that may be inadvertently introduced during the service operation.

If any fuse (or Fusible Resistor) in this monitor is blown, replace it with the specified.

When replacing a high wattage resistor (Oxide Metal Film Resistor, over 1W), keep the resistor 10mm away from PCB.

Keep wires away from high voltage or high temperature parts.

Due to high vacuum and large surface area of picture tube, extreme care should be used in **handling the Picture Tube**. Do not lift the Picture tube by its Neck.

### Leakage Current Cold Check(Antenna Cold Check)

With the instrument AC plug removed from AC source, connect an electrical jumper across the two AC plug prongs. Place the AC switch in the on position, connect one lead of ohm-meter to the AC plug prongs tied together and touch other ohm-meter lead in turn to each exposed metallic parts such as antenna terminals, phone jacks, etc.

If the exposed metallic part has a return path to the chassis, the measured resistance should be between  $1M\Omega$  and  $5.2M\Omega$ .

When the exposed metal has no return path to the chassis the reading must be infinite.

An other abnormality exists that must be corrected before the receiver is returned to the customer.

### Leakage Current Hot Check (See below Figure)

Plug the AC cord directly into the AC outlet.

**Do not use a line Isolation Transformer during this check.**

Connect 1.5K/10watt resistor in parallel with a 0.15uF capacitor between a known good earth ground (Water Pipe, Conduit, etc.) and the exposed metallic parts.

Measure the AC voltage across the resistor using AC voltmeter with 1000 ohms/volt or more sensitivity.

Reverse plug the AC cord into the AC outlet and repeat AC voltage measurements for each exposed metallic part. Any voltage measured must not exceed 0.75 volt RMS which is corresponds to 0.5mA.

In case any measurement is out of the limits specified, there is possibility of shock hazard and the set must be checked and repaired before it is returned to the customer.

### Leakage Current Hot Check circuit

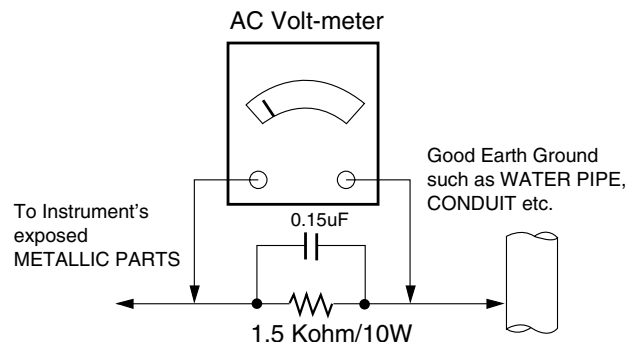

# SPECIFICATION

**NOTE :** Specifications and others are subject to change without notice for improvement.

## 1. Application Range

(1) This spec sheet is applied all of PDP TV with PB11K chassis.

Model Name	Market	Brand
50PT490B-SA 50PT490B-SD	Brazil / chile / Peru / Venezuela / Costarica / Uruguay	LG

## 2. Specification

Each part is tested as below without special appointment.

(1) Temperature : 25 °C ± 5 °C (77 °F ± 9 °F), CST : 40 °C ± 5 °C

(2) Relative Humidity : 65 % ± 10 %

(3) Power Voltage : Standard input voltage (100 V - 240 V ~ 50 / 60 Hz)

\* Standard Voltage of each product is marked by models

(4) Specification and performance of each parts are followed each drawing and specification by part number in accordance with BOM.

(5) The receiver must be operated for about 5 minutes prior to the adjustment.

## 3. Test Method

(1) Performance : LGE TV test method followed.

(2) Demanded other specification

Safety : CE, IEC specification

Model Name	Market	Appliance
50PT490B-SA 50PT490B-SD	Brazil / chile / Peru / Venezuela/ Costarica / Uruguay	Safety : IEC / EN60065

## 4. General Specification

No	Item	Specification	Remark
1.	Receiving System	1) SBTVD / NTSC / PAL-M / PAL-N	PW350B, PV550B, PT250B, PT350B
		2) DVB-T	PW350E, PV550E, PT250E, PT260E
2.	Available Channel	1) VHF : 02~13 2) UHF : 14~69 3) DTV : 07-69 (VHF high/UHF) 4) CATV : 02~135	PW350B, PV550B, PT250B, PT260E
		1) VHF : 02~13 2) UHF : 14~69 3) DTV : 14~69 (UHF) 4) CATV : 02~135	PW350E, PV550E, PT250E, PT260E
3.	Input Voltage	1)AC 100 ~ 240V 50/60Hz	
4.	Market	Brazil / Chile / Peru / Venezuela / Costa Rica / Uruguay	PW350B, PV550B, PT250B, PT350B
		Colombia / Panama	PW350E, PV550E, PT250E, PT260E
5.	Screen Size	42 inch Wide(1024 x 768)	PW350B, PW350E, PT350B PT250B, PT250E, PT260E
		50 inch Wide(1024 x 768)	PW350B, PW350E, PT350B PT250B, PT250E, PT260E
		50 inch Wide(1024 x 768)	PV550B, PV550E
		60 inch Wide(1024 x 768)	PV550B, PV550E
6.	Aspect Ratio	16:9	50/42PW350B-SA 50/42PW350E-DC
7.	Tuning System	FS	
8.	Module	PDP42T3 (3D)#### (1024 x 768)	42PW###
		PDP42T3N (2D)#### (1024 x 768)	42PT###
		PDP50T3 (3D)#### (1024 x 768)	50PW###
		PDP50T3N (2D)#### (1024 x 768)	50PT###
		PDP60R3 #### (1920 x 1080)	60PZ###, 60PV###
		PDP50R3 #### (1920 x 1080)	50PZ###, 50PV###
9.	Operating Environment	1) Temp : 0 ~ 40 deg	
		2) Humidity : ~ 80 %	
10.	Storage Environment	1) Temp : -20 ~ 60 deg	
		2) Humidity : 0 ~ 90 %	

# ADJUSTMENT INSTRUCTION

## 1. Application Range

This spec. sheet applies to PB11K Chassis applied PDP TV all models manufactured in TV factory.

## 2. Specification

- (1) Because this is not a hot chassis, it is not necessary to use an isolation transformer. However, the use of isolation transformer will help protect test instrument.
- (2) Adjustment must be done in the correct order. But it is flexible when its factory local problem occurs.
- (3) The adjustment must be performed in the circumstance of 25 °C ± 5 °C of temperature and 65 % ± 10 % of relative humidity if there is no specific designation.
- (4) The input voltage of the receiver must keep 100 V - 240 V, 50 / 60 Hz.
- (5) Before adjustment, execute Heat-Run for 5 minutes.

- After Receive 100% Full white pattern (06CH) then process Heat-run (or "8. Test pattern" condition of Ez-Adjust status)
- How to make set white pattern

- 1) Press Power ON button of Service Remocon
- 2) Press ADJ button of Service remocon. Select "10. Test pattern" and, after select "White" using navigation button, and then you can see 100% Full White pattern.

\* In this status you can maintain Heat-Run useless any pattern generator

\* Notice: if you maintain one picture over 20 minutes (Especially sharp distinction black with white pattern – 13Ch, or Cross hatch pattern – 09Ch) then it can appear image stick near black level.

## 3. Adjustment items

### 3-1. PCB Assembly adjustment

- (1) Adjust 480i Comp1
- (2) Adjust 1080p Comp1/RGB
  - If it is necessary, it can adjustment at Manufacture Line
  - You can see set adjustment status at "9. ADJUST CHECK" of the "In-start menu"

### 3-2. Set Assembly Adjustment

- (1) EDID (The Extended Display Identification Data )
- (2) Color Temperature (White Balance) Adjustment
- (3) Make sure RS-232C control
- (4) Selection Factory output option

## 4. PCB Assembly Adjustment

### 4-1. Using RS-232C

- Adjust 3 items at 3-1 PCB assembly adjustments
- " (3) Adjustment sequence" one after the order.

#### (1) Adjustment protocol

Order	Command	Set response
1. Inter the Adjustment mode	aa 00 00	a 00 OK00x
2. Change the Source	XB 00 40 XB 00 60	b 00 OK40x (Adjust 480i Comp1 ) (Adjust 1080p Comp1) b 00 OK60x (Adjust 1080p RGB)
3. Start Adjustment	ad 00 10	
4. Return the Response		OKx ( Success condition ) NGx ( Failed condition )
5. Read data Adjustment data	( main ) ad 00 20 ( main ) ad 00 30	(main : component1 480i, RGB 1080p) 000000000000000000000000000000007c007b006dx (main : component1 480i, RGB 1080p) 000000070000000000000000000000007c00830077x
6. Confirm Adjustment	ad 00 99	NG 03 00x (Failed condition) NG 03 01x (Failed condition) NG 03 02x (Failed condition) OK 03 03x (Success condition)
7. End of Adjustment	ad 00 90	d 00 OK90x

< See ADC Adjustment RS232C Protocol\_Ver1.0 >

#### (2) Necessary items before Adjustment items

- Pattern Generator : (MSPG-925FA)
- Adjust 480i Comp1  
(MSPG-925FA:model :209, pattern :65) – Comp1 Mode
- Adjust 1080p Comp1  
(MSPG-925FA:model :225, pattern :65) – Comp1 Mode
- Addjust RGB (MSPG-925FA:model :225, pattern :65)  
– RGB-PC Mode

\* If you want more information then see the below Adjustment method (Factory Adjustment)

#### (3) Adjustment sequence

- aa 00 00: Enter the ADC Adjustment mode.
- xb 00 40: Change the mode to Component1 (No actions)
- ad 00 10: Adjust 480i Comp
- ad 00 10: Adjust 1080p comp
- xb 00 60: Change to RGB-PC mode(No action)
- ad 00 10: Adjust 1080p RGB
- xb 00 90: Endo of Adjustmennt

## 5. Factory Adjustment

PU11A / PB11A : USE INTERNAL ADC(S7R) : using internal pattern.

### 5-1. Auto Adjust Component 480i/1080p RGB 1080p

(1) Summary : Adjustment component 480i/1080i and RGB 1080p is Gain and Black level setting at Analog to Digital converter, and compensate the RGB deviation

(2) Using instrument

- 1) Adjustment remocon, 801GF(802B, 802F, 802R) or MSPG925FA pattern generator  
(It can output 480i/1080i horizontal 100 % color bar pattern signal, and its output level must setting  $0.7 V \pm 0.1 V$  p-p correctly)

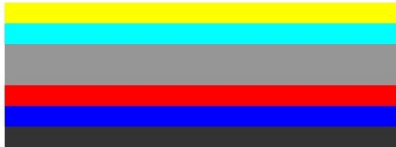

< Adjustment pattern : 480i / 1080p 60Hz Pattern >

\* You must make it sure its resolution and pattern cause every instrument can have different setting

2) Adjustment method 480i Comp1, Adjust 1080p Comp1/RGB (Factory adjustment)

- ADC 480i Component1 adjustment -
  - Check connection of Component1
  - MSPG-925FA Model: 209, Pattern 65
- Set Component 480i mode and 100% Horizontal Color Bar Pattern(HozTV31Bar), then set TV set to Component1 mode and its screen to "NORMAL"
- ADC 1080p Component1 / RGB adjustment
  - Check connection both of Component1 and RGB
  - MSPG-925FA Model: 225, Pattern 65
- Set Component 1080p mode and 100% Horizontal Color Bar Pattern(HozTV31Bar), then set TV set to Component1 mode and its screen to "NORMAL"
- After get each the signal, wait more a second and enter the "IN-START" with press IN-START key of Service remocon. After then select "7. External ADC" with navigator button and press "Enter".
- After Then Press key of Service remocon "Right Arrow(VOL+)"
- You can see "ADC Component1 Success"
- Component1 1080p, RGB 1080p Adjust is same method.
- Component 1080p Adjustment in Component1 input mode
- RGB 1080p adjustment in RGB input mode
- If you success RGB 1080p Adjust. You can see "ADC RGB-DTV Success"

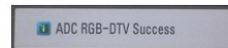
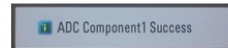
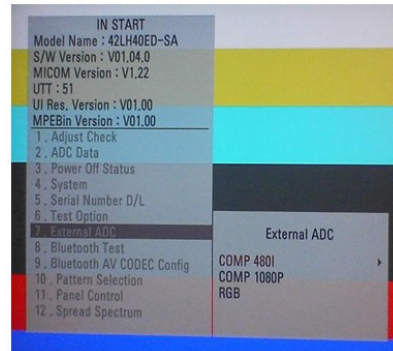

Caution : Set Volume 0 after adjustment

### 5-2. Use Internal ADC(S7R)

- ADJ(EZ ADJUST) -> 6.ADC Calibration -> ADC Calibration(START)

### 5-3. EDID(The Extended Display Identification Data) / DDC(Display Data Channel) download

(1) Summary

- 1) It is established in VESA, for communication between PC and Monitor without order from user for building user condition. It helps to make easily use realize "Plug and Play" function.
- 2) For EDID data write, we use DDC2B protocol.

### 5-4. Auto Download

- (1) After enter Service Mode by pushing "ADJ" key,
- (2) Enter EDID D/L mode.
- (3) Enter "START" by pushing "OK" key.

Caution

- Never connect HDMI & D-sub Cable when the user downloading .
- Use the proper cables below for EDID Writing.

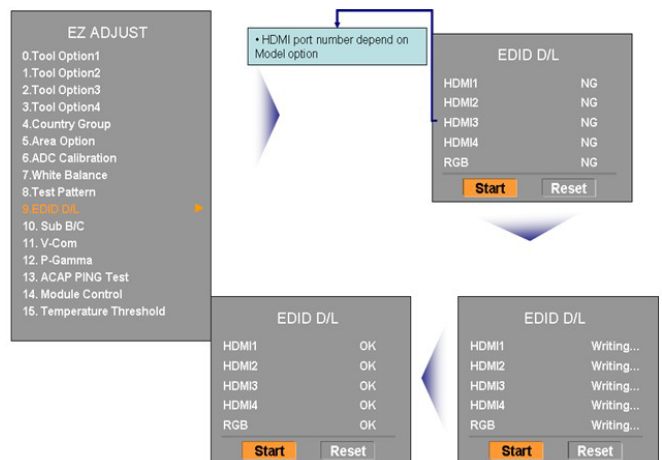

- It only needs to PCM EDID D/L for North America Product. (PU11A)

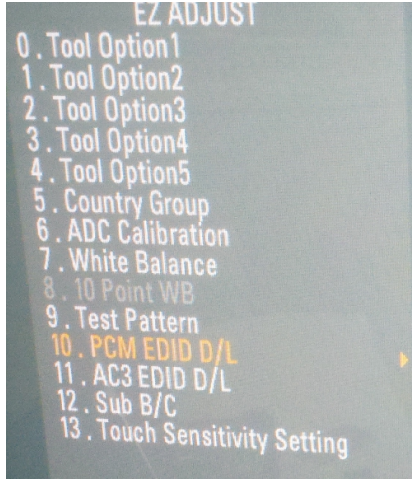

EDID data (Model name = LG TV)

HDMI-1 EDID table(2D HD) -  
- North America & South Centural America  
(PT350B, PT250B/E, PT260E/PT490/U/R)

	0	1	2	3	4	5	6	7	8	9	A	B	C	D	E	F
0	00	FF	FF	FF	FF	FF	FF	00	1E	6D	01	00	01	01	01	01
10	01	15	01	03	80	A0	5A	78	0A	EE	91	A3	54	4C	99	26
20	0F	50	54	A1	08	00	31	40	45	40	61	40	01	01	01	01
30	01	01	01	01	01	01	64	19	00	40	41	00	26	30	18	88
40	36	00	40	84	63	00	00	1C	A0	0F	20	00	31	58	1C	20
50	28	80	11	00	BC	39	20	00	00	00	00	00	00	FD	00	3A
60	3E	1E	53	10	00	0A	20	20	20	20	20	20	00	00	00	FC
70	00	4C	47	20	54	56	0A	20	20	20	20	20	20	20	01	0F
0	02	03	27	F1	4E	02	03	11	12	93	04	15	16	05	14	10
10	1F	22	20	26	15	07	50	09	57	07	68	03	0C	00	10	00
20	B8	2D	00	E3	05	03	01	02	3A	80	18	71	38	2D	40	58
30	2C	45	00	40	84	63	00	00	1E	01	1D	80	18	71	1C	16
40	20	58	2C	25	00	40	84	63	00	00	9E	01	1D	00	72	51
50	D0	1E	20	6E	28	55	00	40	84	63	00	00	1E	00	00	00
60	00	00	00	00	00	00	00	00	00	00	00	00	00	00	00	00
70	00	00	00	00	00	00	00	00	00	00	00	00	00	00	00	D2

\* Edid data and Model option download(RS232)

NO	Item	CMD 1	CMD 2	Data 0	Data 1	
Enter download MODE	Download 'Mode In'	A	E	0	0	When transfer the 'Mode In', Carry the command.
Edid data and Model option download	Download	A	E	*Note1	*Note2	Automatically download (The use of a internal Data)
	Adjust 'Mode Out'	A	E	9	0	
	Adjustment Confirmation	A	E	9	9	To check Download on Assembly line.

HDMI-2 EDID table(2D HD)

- North America & South Centural America  
(PT350B, PT250B/E, PT260E/PT490/U/R)

	0	1	2	3	4	5	6	7	8	9	A	B	C	D	E	F
0	00	FF	FF	FF	FF	FF	FF	00	1E	6D	01	00	01	01	01	01
10	01	15	01	03	80	A0	5A	78	0A	EE	91	A3	54	4C	99	26
20	0F	50	54	A1	08	00	31	40	45	40	61	40	01	01	01	01
30	01	01	01	01	01	01	64	19	00	40	41	00	26	30	18	88
40	36	00	40	84	63	00	00	1C	A0	0F	20	00	31	58	1C	20
50	28	80	11	00	BC	39	20	00	00	00	00	00	00	FD	00	3A
60	3E	1E	53	10	00	0A	20	20	20	20	20	20	00	00	00	FC
70	00	4C	47	20	54	56	0A	20	20	20	20	20	20	20	01	0F
0	02	03	27	F1	4E	02	03	11	12	93	04	15	16	05	14	10
10	1F	22	20	26	15	07	50	09	57	07	68	03	0C	00	20	00
20	B8	2d	00	E3	05	03	01	02	3A	80	18	71	38	2D	40	58
30	2C	45	00	40	84	63	00	00	1E	01	1E	80	18	71	1C	16
40	20	58	2C	25	00	40	84	63	00	00	9E	01	1D	00	72	51
50	D0	1E	20	6E	28	55	00	40	84	63	00	00	1E	00	00	00
60	00	00	00	00	00	00	00	00	00	00	00	00	00	00	00	00
70	00	00	00	00	00	00	00	00	00	00	00	00	00	00	00	C2

## 5-5. Manual Download

(1) Write HDMI EDID data

1) Using instruments

- Jig. (PC Serial to D-Sub connection) for PC, DDC adjustment.
- S/W for DDC recording (EDID data write and read)
- D-sub jack
- Additional HDMI cable connection Jig.

2) Preparing and setting.

- Set instruments and Jig. Like pic.5), then turn on PC and Jig.
- Operate DDC write S/W (EDID write & read)
- It will operate in the DOS mode.

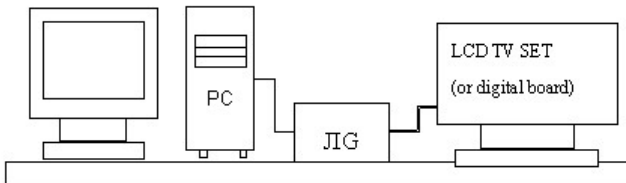

< For write EDID data, setting Jig and another instruments >



HDMI-3 EDID table(2D HD)  
 - North America & South Centural America  
 (PT350B, PT250B/E, PT260E/PT490/U/R)

0	1	2	3	4	5	6	7	8	9	A	B	C	D	E	F
0	00	FF	FF	FF	FF	FF	FF	00	1E	6D	01	00	01	01	01
10	01	15	01	03	80	A0	5A	78	0A	EE	91	A3	54	4C	99
20	0F	50	54	A1	08	00	31	40	45	40	61	40	01	01	01
30	01	01	01	01	01	01	64	19	00	40	41	00	26	30	18
40	36	00	40	84	63	00	00	1C	A0	0F	20	00	31	58	1C
50	28	80	11	00	BC	39	20	00	00	00	00	00	FD	00	3A
60	3E	1E	53	10	00	0A	20	20	20	20	20	20	00	00	FC
70	00	4C	47	20	54	56	0A	20	20	20	20	20	20	01	0F
0	02	03	27	F1	4E	02	03	11	12	93	04	15	16	05	14
10	1F	22	20	26	15	07	50	09	57	07	68	03	0C	00	30
20	B8	2d	00	E3	05	03	01	02	3A	80	18	71	38	2D	40
30	2C	45	00	40	84	63	00	00	1E	01	1D	80	18	71	1C
40	20	58	2C	25	00	40	84	63	00	00	9E	01	1D	00	72
50	D0	1E	20	6E	28	55	00	40	84	63	00	00	1E	00	00
60	00	00	00	00	00	00	00	00	00	00	00	00	00	00	00
70	00	00	00	00	00	00	00	00	00	00	00	00	00	00	B2

RGB EDID table(2D HD)  
 - North America & South Centural America  
 (PT350B, PT250B/E, PT260E/PT490/U/R)

0	1	2	3	4	5	6	7	8	9	A	B	C	D	E	F
0	00	FF	FF	FF	FF	FF	FF	00	1E	6D	01	00	01	01	01
10	01	15	01	03	68	A0	5A	78	0A	EE	91	A3	54	4C	99
20	0F	50	54	A1	08	00	31	40	45	40	61	40	01	01	01
30	01	01	01	01	01	01	64	19	00	40	41	00	26	30	18
40	36	00	40	84	63	00	00	1C	A0	0F	20	00	31	58	1C
50	28	80	11	00	BC	39	20	00	00	00	00	00	FD	00	3A
60	3E	1E	53	10	00	0A	20	20	20	20	20	20	00	00	FC
70	00	4C	47	20	54	56	0A	20	20	20	20	20	20	00	28

\* See Working Guide if you want more information about EDID communication.

## 5-6. Adjustment Color Temperature (White balance)

### (1) Using Instruments

- 1) Color Analyzer: CA-210 (CH 9)
  - Using LCD color temperature, Color Analyzer (CA-210) must use CH 9, which Matrix compensated (White, Red, Green, Blue compensation) with CS-2100. See the Coordination bellowed one.
- 2) Auto-adjustment Equipment (It needs with Auto-adjustment – It is availed communicate with RS-232C : Baud rate: 115200)
- 3) Video Signal Generator MSPG-925F 720p, 216Gray (Model: 217, Pattern 78)

### (2) Connection Diagram (Auto Adjustment)

#### 1) Using Inner Pattern

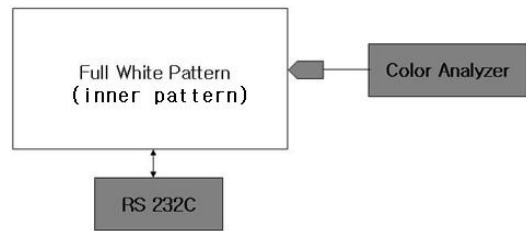

#### 2) Using HDMI input

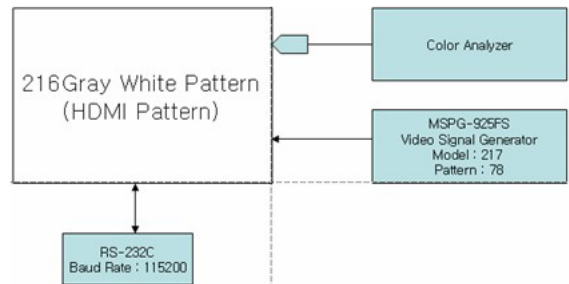

< Connection Diagram for Adjustment White balance >

### (3) White Balance Adjustment

- If you can't adjust with inner pattern, then you can adjust it using HDMI pattern. You can select option at "Ez-Adjust Menu – 7. White Balance" there items "NONE, INNER, HDMI". It is normally setting at inner basically. If you can't adjust using inner pattern you can select HDMI item, and you can adjust.

- In manual Adjust case, if you press ADJ button of service remocon, and enter "Ez-Adjust Menu – 7. White Balance", then automatically inner pattern operates. (In case of "Inner" originally "Test-Pattern. On" will be selected in The "Test-Pattern. On/Off".

- Connect all cables and equipments like Pic.5)
- Set Baud Rate of RS-232C to 115200. It may set 115200 orignally.
- Connect RS-232C cable to set
- Connect HDMI cable to set

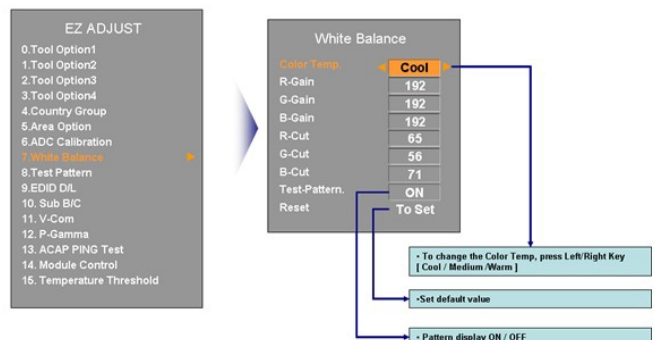

■ RS-232C COMMAND(Commonly apply)

RS-232C COMMAND			Meaning
[CMD]	ID	DATA]	
wb	00	00	White Balance adjustment start.
wb	00	10	Start of adjust gain (Inner white pattern)
wb	00	1f	End of gain adjust
wb	00	20	Start of offset adjust (Inner white pattern)
wb	00	2f	End of offset adjust
wb	00	ff	End of White Balance adjust (Inner pattern disappeared)

- "wb 00 00": Start Auto-adjustment of white balance.
- "wb 00 10": Start Gain Adjustment (Inner pattern)
- "jb 00 c0" :
- ...
- "wb 00 1f": End of Adjustment  
\* If it needs, offset adjustment (wb 00 20-start, wb 00 2f-end)
- "wb 00 ff": End of white balance adjustment (inner pattern disappear)

■ Adjustment Mapping information

	RS-232C COMMAND			MIN	CENTER			MAX
	[CMD ID DATA]				(DEFAULT)			
	Cool	Mid	Warm	Cool	Mid	Warm		
R Gain	jd	Ja	jd	00	184	192	192	192
G Gain	jh	Jb	je	00	187	183	159	192
B Gain	ji	Jc	jf	00	192	161	95	192
R Cut					64	64	64	127
G Cut					64	64	64	127
B Cut					64	64	64	127

- When Color temperature (White balance) Adjustment (Automatically)  
- Press "Power only key" of service remocon and operate automatically adjustment.  
- Set BaudRate to 115200.
- You must start "wb 00 00" and finish it "wb 00 ff".
- If it needs, then adjustment "Offset".

(4) White Balance Adjustment (Manual adjustment)

- 1) Test Equipment: CA-210  
- Using PDP color temperature, Color Analyzer (CA-210) must use CH 10, which Matrix compensated (White, Red, Green, Blue compensation) with CS-2100. See the Coordination bellowed one.
- 2) Manual adjustment sequence is like bellowed one.  
- Turn to "Ez-Adjust" mode with press ADJ button of service remocon.  
- Select "10.Test Pattern" with CH+/- button and press enter. Then set will go on Heat-run mode. Over 30 minutes set let on Heat-run mode.  
- Let CA-210 to zero calibration and must has gap more 10cm from center of PDP module when adjustment.  
- Press "ADJ" button of service remocon and select "7.White-Balance" in "Ez-Adjust" then press "▶" button of navigation key. (When press "▶" button then set will go to full white mode)  
- Adjust at three mode (Cool, Medium, Warm)  
- If "cool" mode  
Let B-Gain to 192 and R, G, B-Cut to 64 and then control R, G gain adjustment High Light adjustment.  
- If "Medium" and "Warm" mode Let R-Gain to 192 and R, G, B-Cut to 64 and then control G, B gain adjustment High Light adjustment.  
- All of the three mode  
Let R-Gain to 192 and R, G, B-Cut to 64 and then control G, B gain adjustment High Light adjustment.  
- With volume button (+/-) you can adjust.  
- After all adjustment finished, with Enter ( \_ key) turn to Ez-Adjust mode. Then with ADJ button, exit from adjustment mode

\* Attachment: White Balance adjustment coordination and color temperature.

- Using CS-1000 Equipment.  
- COOL : T=11000K, \_uv=0.000, x=0.276 y=0.283  
- MEDIUM : T=9300K, \_uv=0.000, x=0.285 y=0.293  
- WARM : T=6500K, \_uv=0.000, x=0.313 y=0.329
- Using CA-210 Equipment. (10 CH)  
- Contras value : 216 Gray

Color temperature	Test Equipment	Color Coordination	
		x	y
COOL	CA-210	0.276 ± 0.002	0.283 ± 0.002
MEDIUM	CA-210	0.285 ± 0.002	0.293 ± 0.002
WARM	CA-210	0.313 ± 0.002	0.329 ± 0.002

- Brighness spec.

Item	Min	Typ	Max	Unit	Remark
White average brightness	49	60	-	cd/m	- 100%Window White Pattern - 100IRE(255Gray) - Picture: Vivid(Medium )
Brightness uniformity	-20		+20	%	- 85IRE(216Gray) 100% Window White Pattern - Picture: Vivid(Medium)

## 6. Test of RS-232C control.

- Press In-Start button of Service Remocon then set the "4.Baud Rate" to 115200. Then check RS-232C control and

## 7. Selection of Country option.

- Selection of country option is allowed only North American model (Not allowed Korean model). It is selection of Country about Rating and Time Zone.

- (1) Models: All models which PB82C Chassis (See the first page.)
- (2) Press "In-Start" button of Service Remocon, then enter the "Option" Menu with "PIP CH-" Button
- (3) Select one of these three (USA, CANADA, MEXICO) depends on its market using "Vol. +/-"button.

Caution : Don't push The INSTOP KEY after completing the function inspection

Caution : Inspection only PAL M / NTSC

## 8. GND and ESD Testing

### 8-1. Prepare GND and ESD Testing.

- Check the connection between set and power cord

### 8-2. Operate GND and ESD auto-test.

- (1) Fully connected (Between set and power cord) set enter the Auto-test sequence.
- (2) Connect D-Jack AV jack test equipment.
- (3) Turn on Auto-controller(GWS103-4)
- (4) Start Auto GND test.
- (5) If its result is NG, then notice with buzzer.
- (6) If its result is OK, then automatically it turns to ESD Test.
- (7) Operate ESD test
- (8) If its result is NG, then notice with buzzer.
- (9) If its result is OK, then process next steps. Notice it with Good lamp and STOPER Down.

### 8-3. Check Items.

- (1) Test Voltage  
GND: 1.5KV/min at 100mA  
Signal: 3KV/min at 100mA
- (2) Test time: just 1 second.
- (3) Test point  
- GND test: Test between Power cord GND and Signal cable metal GND.  
- ESD test: Test between Power cord GND and Live and neutral.
- (4) Leakage current: Set to 0.5mA(rms)

## 9. POWER PCB Ass'y Voltage Adjustment (Va/Vs Voltage Adjustment)

- (1) Test equipment : D.M.M 1EA
- (2) Connection Diagram for Measuring : refer to fig.1

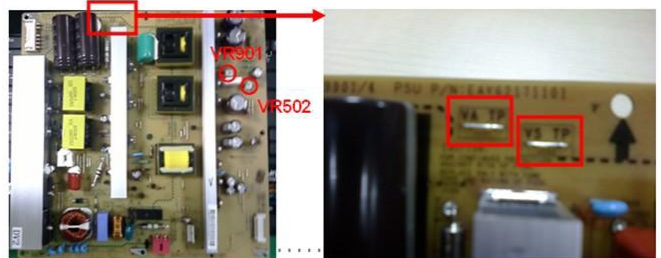

<XPOWER4 50T3 PSU>

< fig.1 : 50 inch Power PCB Assy Voltage adjustment >

### 9-1. Adjustment method

- (1) Vs adjustment (refer fig.1)
  - 1) Connect + terminal of D.M.M. to Vs pin of P811, connect -terminal to GND pin of P811
  - 2) After turning VR901, voltage of D.M.M adjustment as same as Vs voltage which on label of panel left/top ( deviation ;  $\pm 0.5V$ )
- (2) Va adjustment (refer fig.1)
  - 1) After receiving 100% Full White Pattern, HEAT RUN.
  - 2) Connect + terminal of D.M.M. to Va pin of P811, connect -terminal to GND pin of P811.
  - 3) After turning VR502, voltage of D.M.M adjustment as same as Va voltage which on label of panel left/top ( deviation;  $\pm 0.5V$ )

## 10. Default Service option.

### 10-1. ADC-Set.

- R-Gain adjustment Value (default 128)
- G-Gain adjustment Value (default 128)
- B-Gain adjustment Value (default 128)
- R-Offset adjustment Value (default 128)
- G-Offset adjustment Value (default 128)
- B-Offset adjustment Value (default 128)

### 10-2. White balance. Value.

	CENTER (DEFAULT)		
	Cool	Mid	Warm
R Gain	192	192	192
G Gain	192	192	192
B Gain	192	192	192
R Cut	64	64	64
G Cut	64	64	64
B Cut	64	64	64

### 10-3. Temperature Threshold

- Threshold Down Low 20
- Threshold Up Low 23
- Threshold Down High 70
- Threshold Up High 75

### 11. Touch Pen Operating check (Pen touch model only)

- applied model : 50PT490B / 50PT490E / 60PZ850B

- (1) Press Pen mode hot key to insert check mode in POWER ONLY condition.  
(Green Pen mode key on center of remocon)
- (2) Pen check mode  
: You can see a 2X5 matrix.  
(Checker have to use right-hand.)
- (3) 2X5 Matrix construction : When the screen is divided by fixel in 16:9, matrix is applicable 14th,15th fixel in row, 3rd ~ 7th fixel in columne. And they are numbered from 1 to 10.  
(TV & Jig Monitor is numbered samely.)
- (4) When checker touched a box numbered 3 of Pen touch TV, same box of JIG monitor blinks three times.

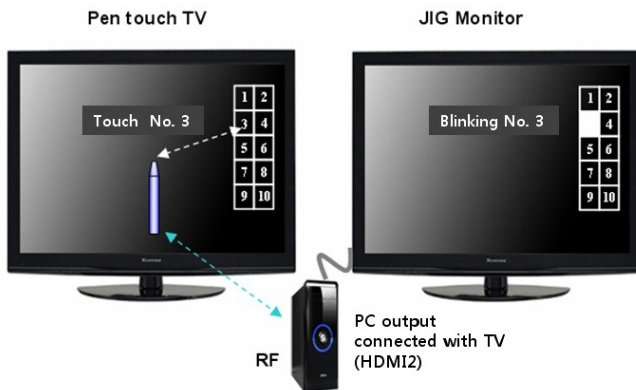

### 12. USB DOWNLOAD (\* .epk file download)

- Put the USB Stick to the USB socket
- Press Menu key, and move OPTION



- Press "FAV" Press 7 times.

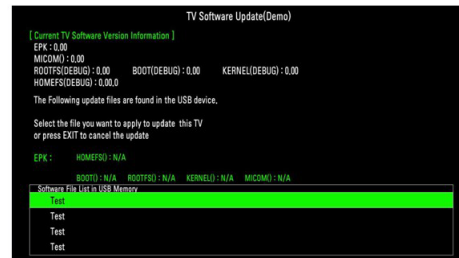

- Select download file (epk file)



- After download is finished, remove the USB stick.
- Press "IN-START" key of ADJ remote control, check the S/W version.

# BLOCK DIAGRAM

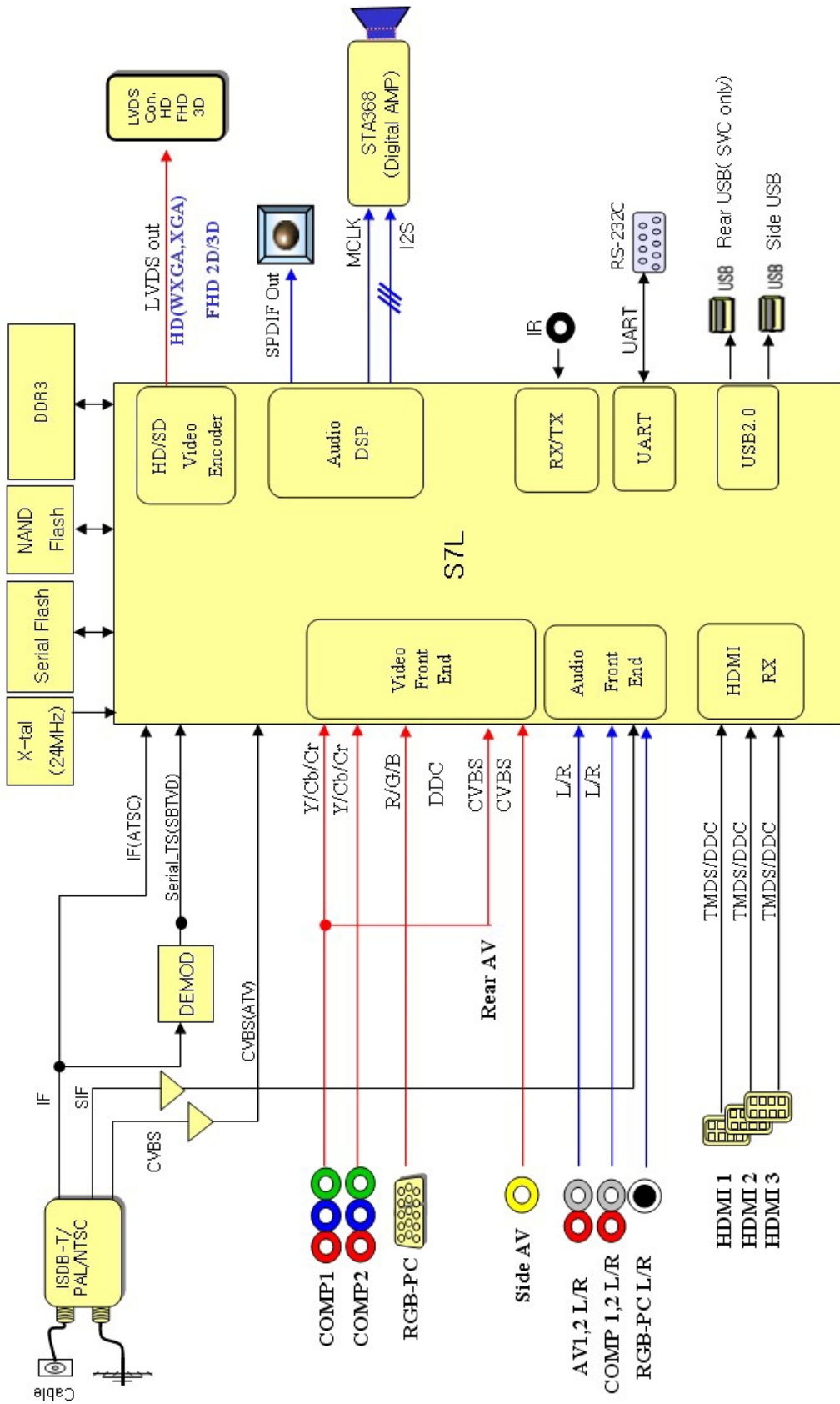

# EXPLODED VIEW

## IMPORTANT SAFETY NOTICE

Many electrical and mechanical parts in this chassis have special safety-related characteristics. These parts are identified by  $\Delta$  in the Schematic Diagram and EXPLODED VIEW. It is essential that these special safety parts should be replaced with the same components as recommended in this manual to prevent X-RADIATION, Shock, Fire, or other Hazards. Do not modify the original design without permission of manufacturer.

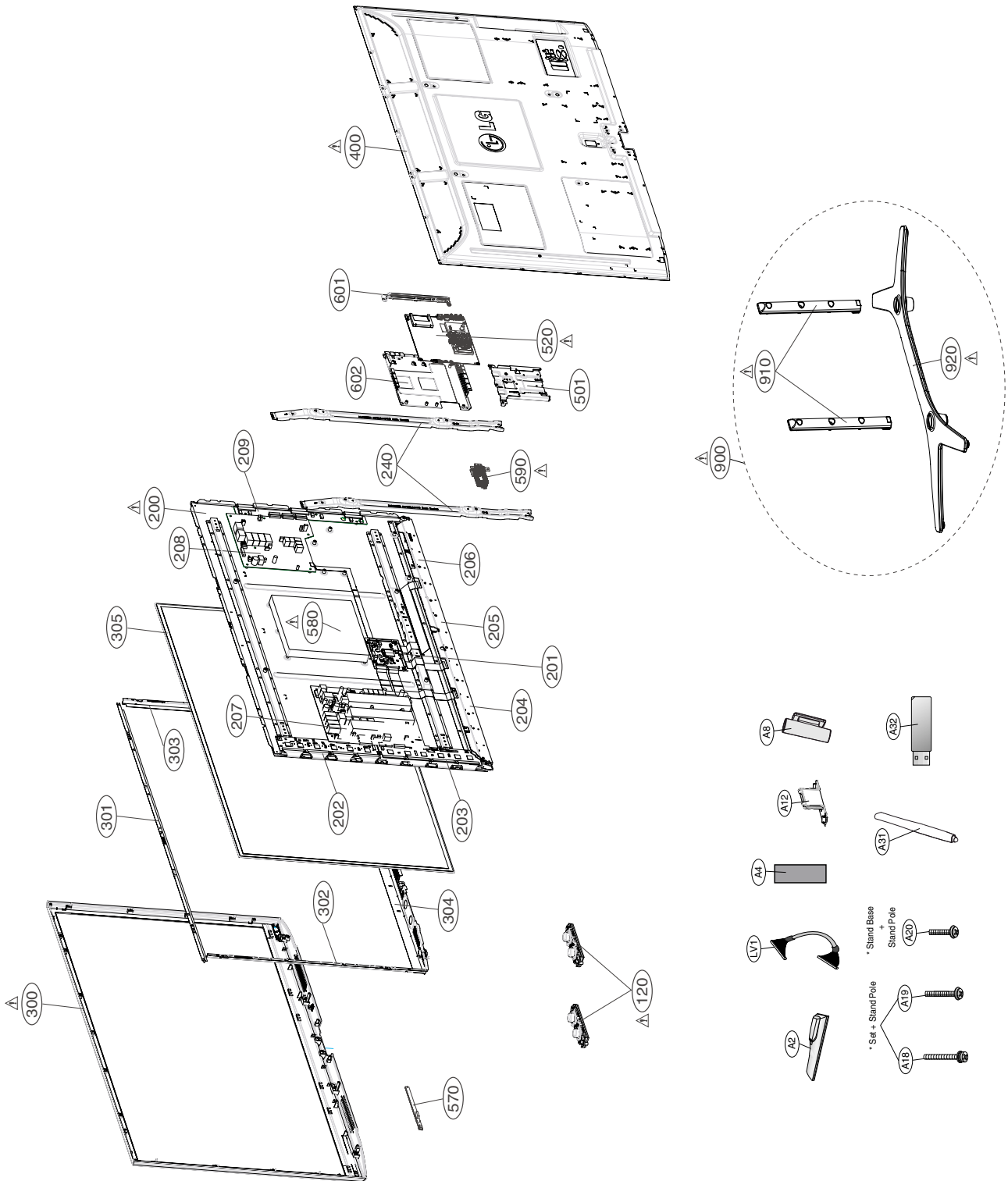

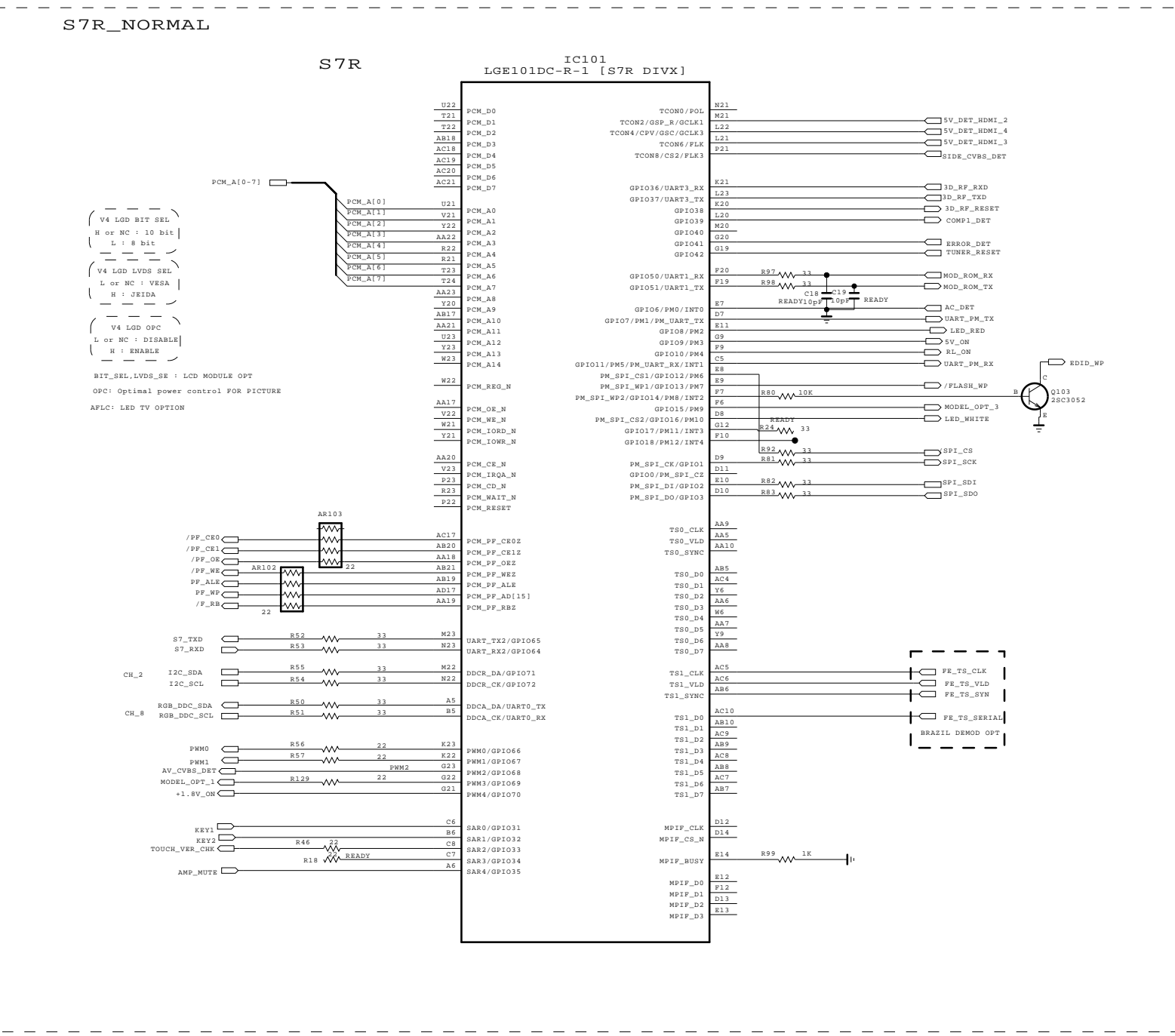
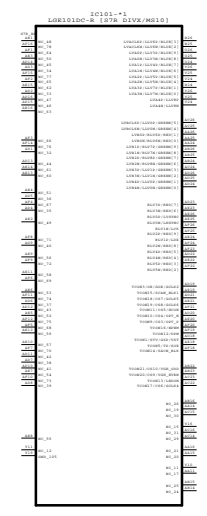
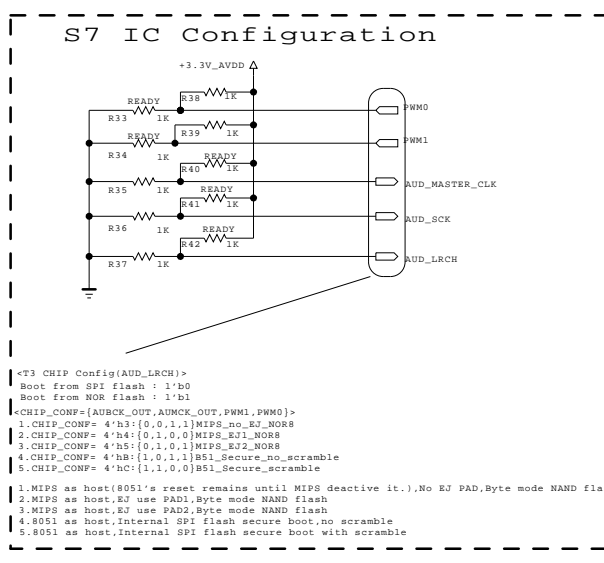
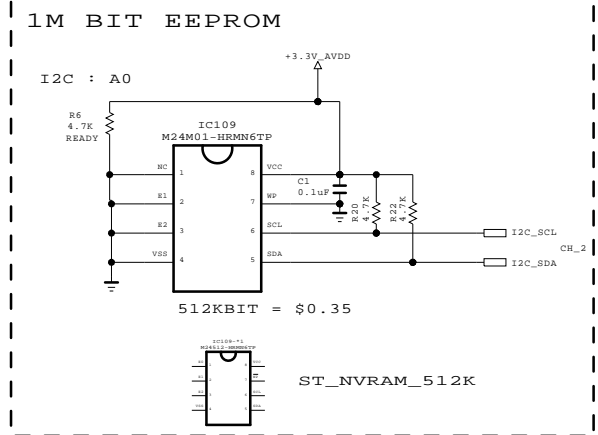
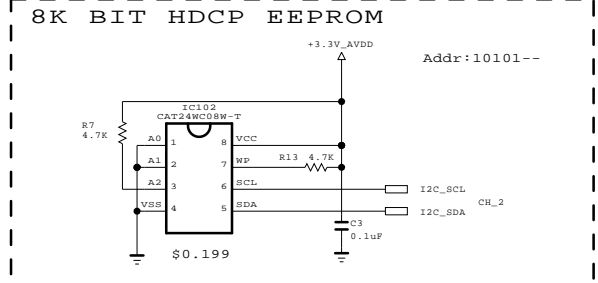
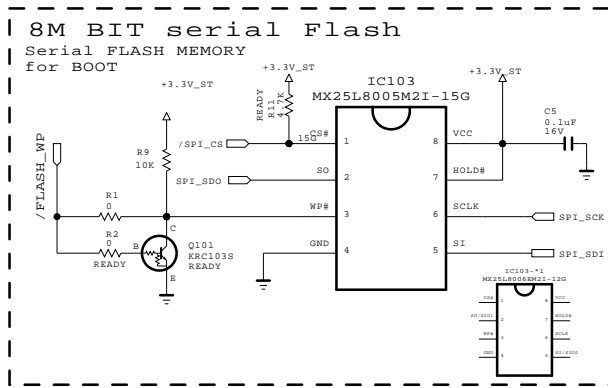
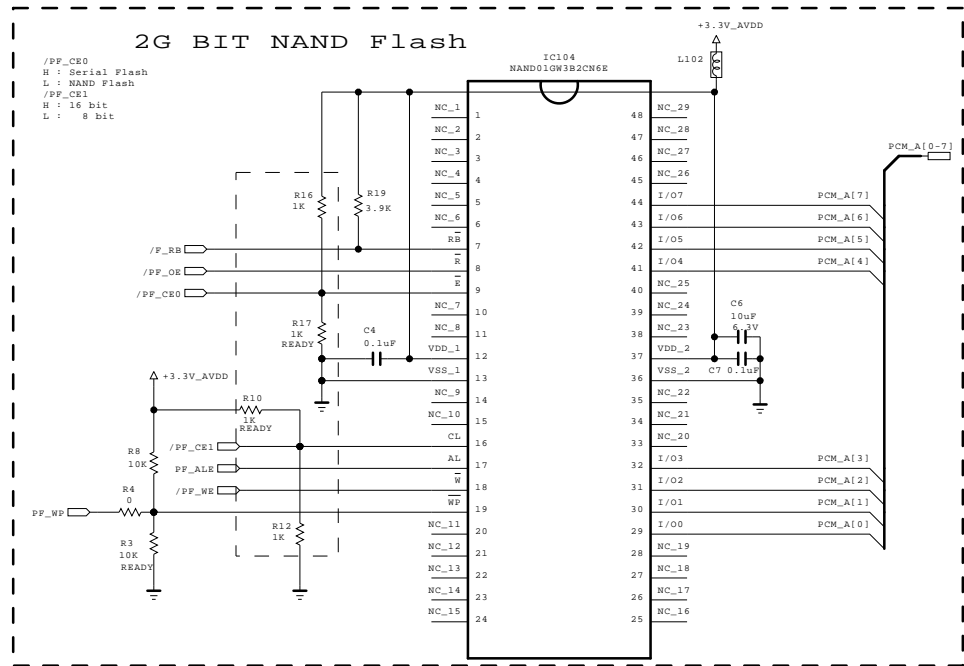

THE SYMBOL MARK OF THIS SCHEMATIC DIAGRAM INCORPORATES SPECIAL FEATURES IMPORTANT FOR PROTECTION FROM X-RADIATION. FILRE AND ELECTRICAL SHOCK HAZARDS, WHEN SERVICING IF IS ESSENTIAL THAT ONLY MANUFACTURES SPECIFIED PARTS BE USED FOR THE CRITICAL COMPONENTS IN THE SYMBOL MARK OF THE SCHEMATIC.

SECRET  
LGElectronics



MODEL	EAX63425902(5)	DATE	2010.10.21
BLOCK	S7/FLASH/NVRAM/GPIO	SHEET	1 / 14



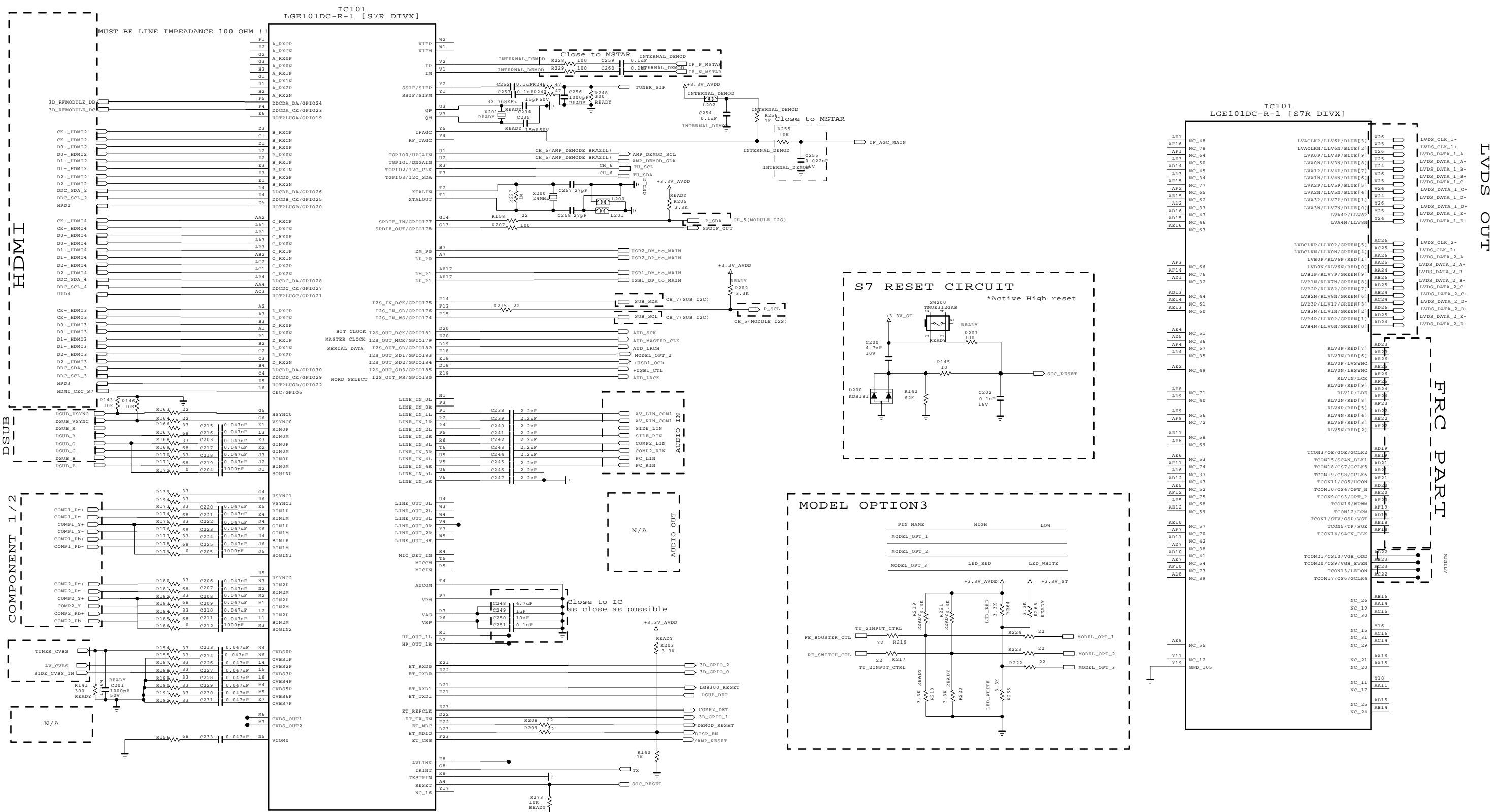

THE SYMBOL MARK OF THIS SCHEMATIC DIAGRAM INCORPORATES SPECIAL FEATURES IMPORTANT FOR PROTECTION FROM X-RADIATION. FILRE AND ELECTRICAL SHOCK HAZARDS, WHEN SERVICING IF IS ESSENTIAL THAT ONLY MANUFACTURES SPECIFIED PARTS BE USED FOR THE CRITICAL COMPONENTS IN THE SYMBOL MARK OF THE SCHEMATIC.

**SECRET**  
 LG ELECTRONICS

LG ELECTRONICS

MODEL	EAX63425902(5)	DATE	2010.10.21
BLOCK	· · 里 · · 留 · · 廣	SHEET	2 / 14



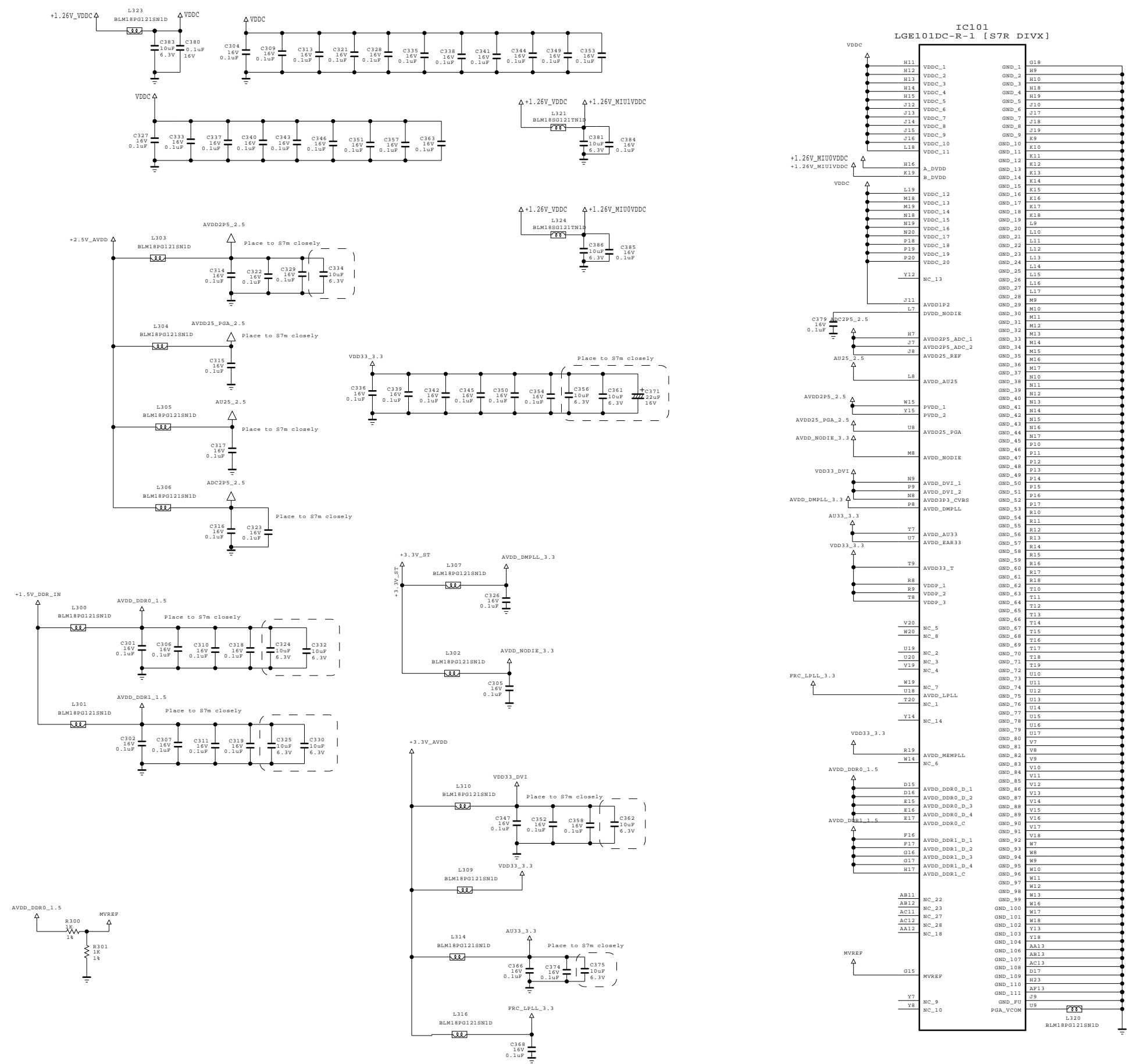

THE SYMBOL MARK OF THIS SCHEMATIC DIAGRAM INCORPORATES SPECIAL FEATURES IMPORTANT FOR PROTECTION FROM X-RADIATION. FILRE AND ELECTRICAL SHOCK HAZARDS, WHEN SERVICING IF IS ESSENTIAL THAT ONLY MANUFACTURES SPECIFIED PARTS BE USED FOR THE CRITICAL COMPONENTS IN THE SYMBOL MARK OF THE SCHEMATIC.

**SECRET**  
LGElectronics



MODEL	EAX63425902(5)	DATE	2010.10.21
BLOCK	Main IC Power	SHEET	3 / 13

POWER Wafer 18P

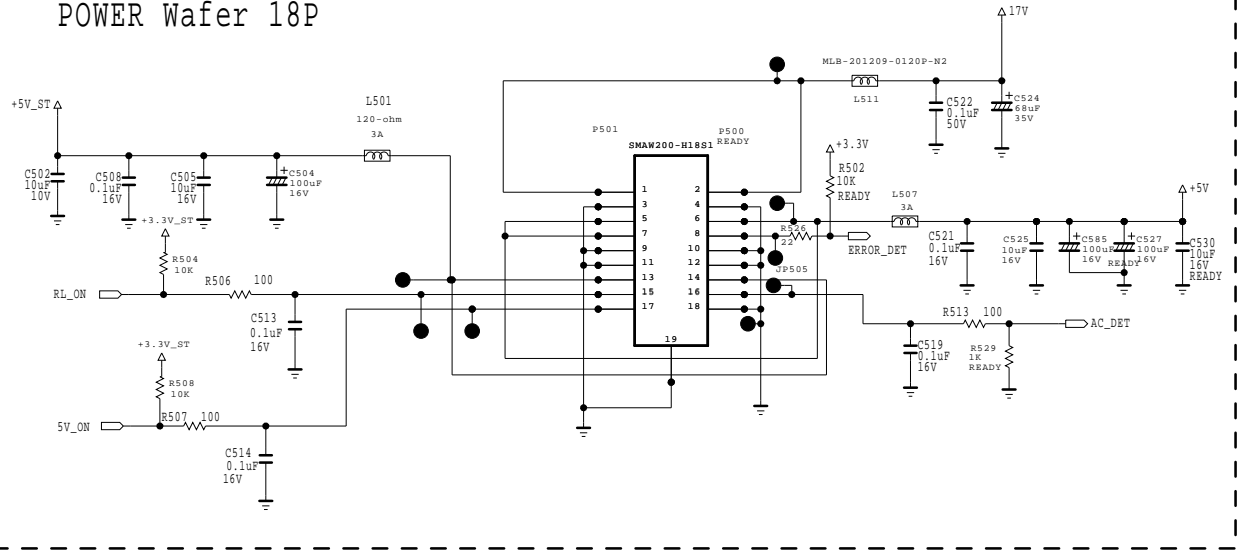

Stand-by (5V\_ST --> +3.3V ST)

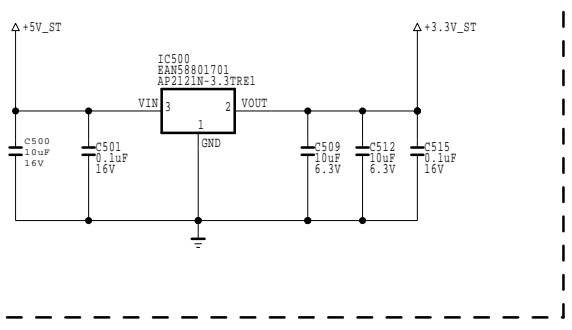

+5V --> +3.3V

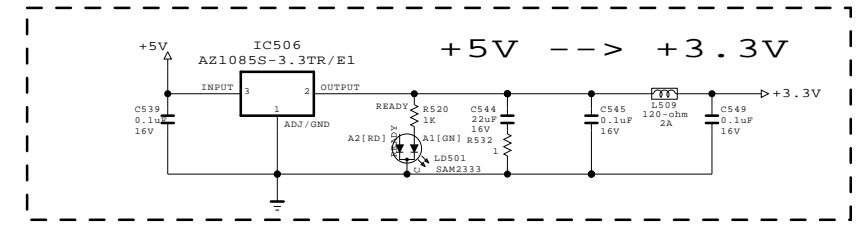

P\_CH FET (+5V\_ST\_EN Source)

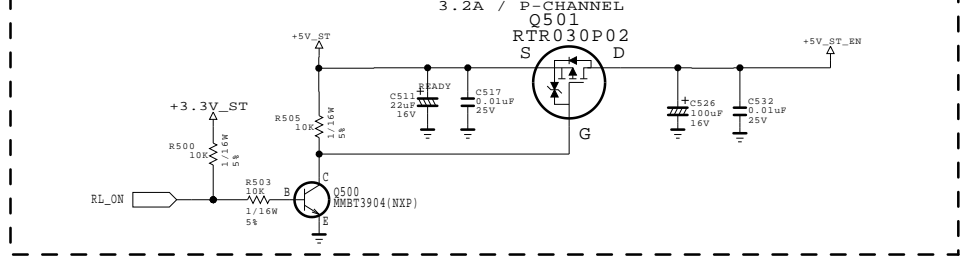

17V => +5V

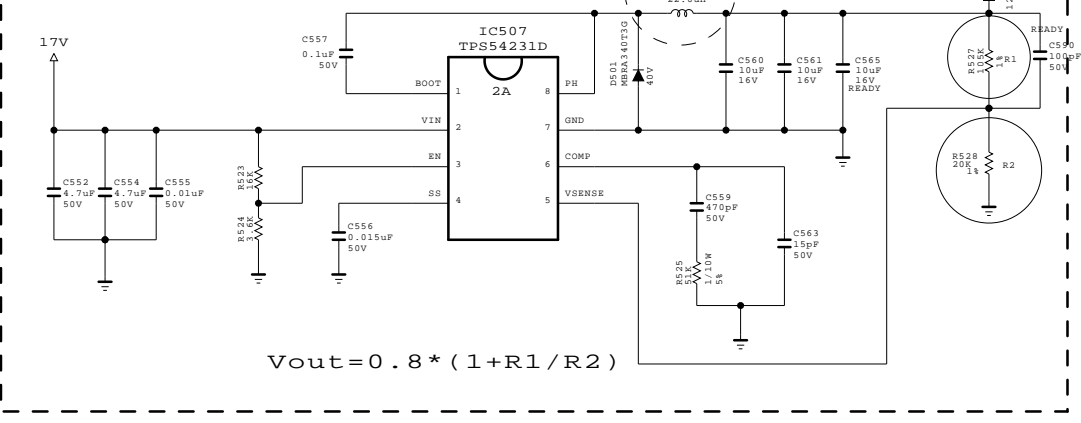

$V_{out} = 0.8 * (1 + R1/R2)$

+5V\_ST\_EN --> +1.5V\_DDR\_IN

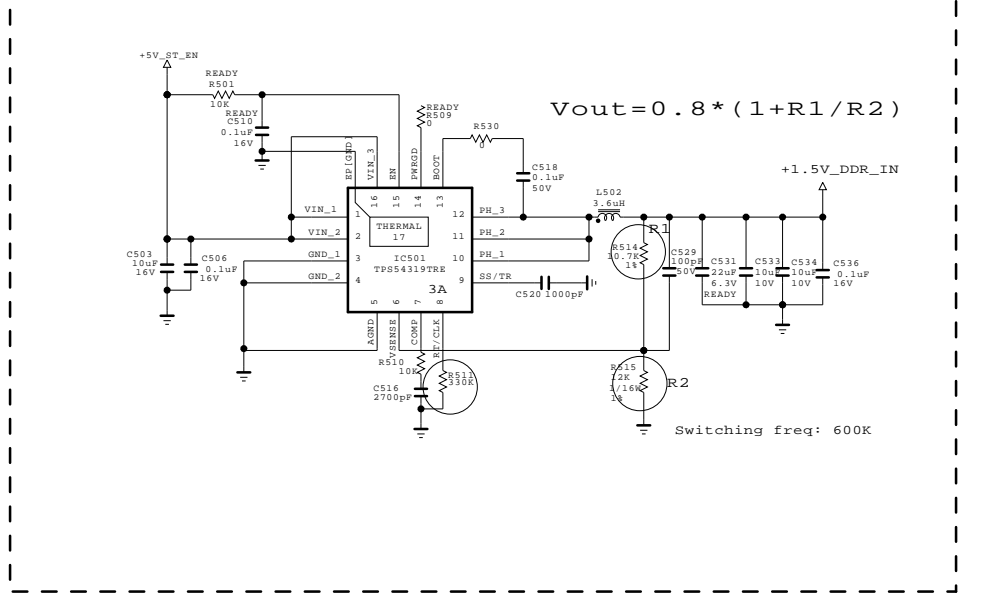

$V_{out} = 0.8 * (1 + R1/R2)$

Switching freq: 600K

+5V\_ST\_EN --> +1.26V\_VDDC

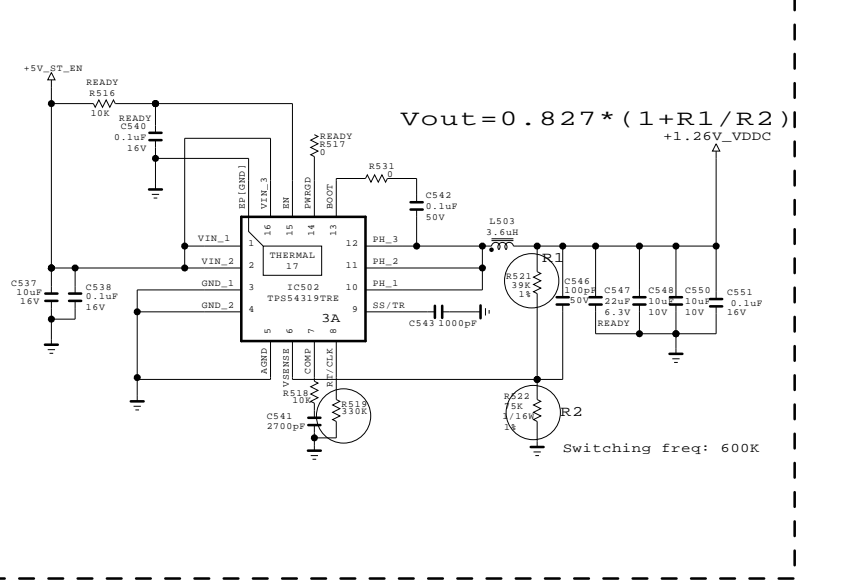

$V_{out} = 0.827 * (1 + R1/R2)$

Switching freq: 600K

+5V\_ST\_EN --> +3.3V\_AVDD

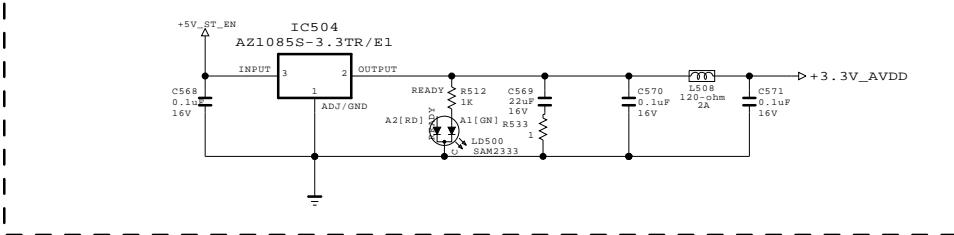

S7 core 2.5V

Multi Power (+3.3V\_AVDD --> 2.5V\_AVDD)

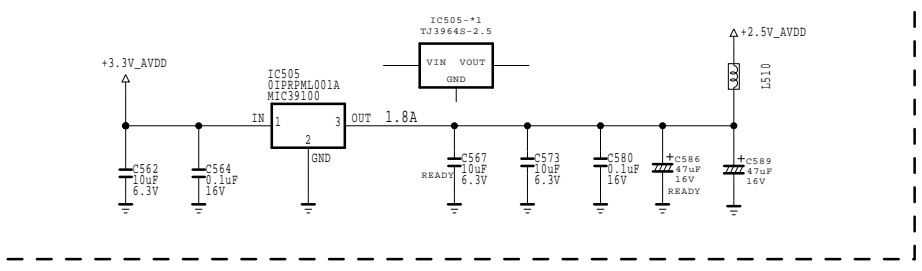

THE  $\Delta$  SYMBOL MARK OF THIS SCHEMATIC DIAGRAM INCORPORATES SPECIAL FEATURES IMPORTANT FOR PROTECTION FROM X-RADIATION. FILRE AND ELECTRICAL SHOCK HAZARDS, WHEN SERVICING IF IS ESSENTIAL THAT ONLY MANUFACTURES SPECIFIED PARTS BE USED FOR THE CRITICAL COMPONENTS IN THE  $\Delta$  SYMBOL MARK OF THE SCHEMATIC.

SECRET  
LGElectronics



MODEL	EAX63425901 (5)	DATE	2010.10.21
BLOCK	POWER	SHEET	5 / 13

# BRAZIL DEMODULATOR

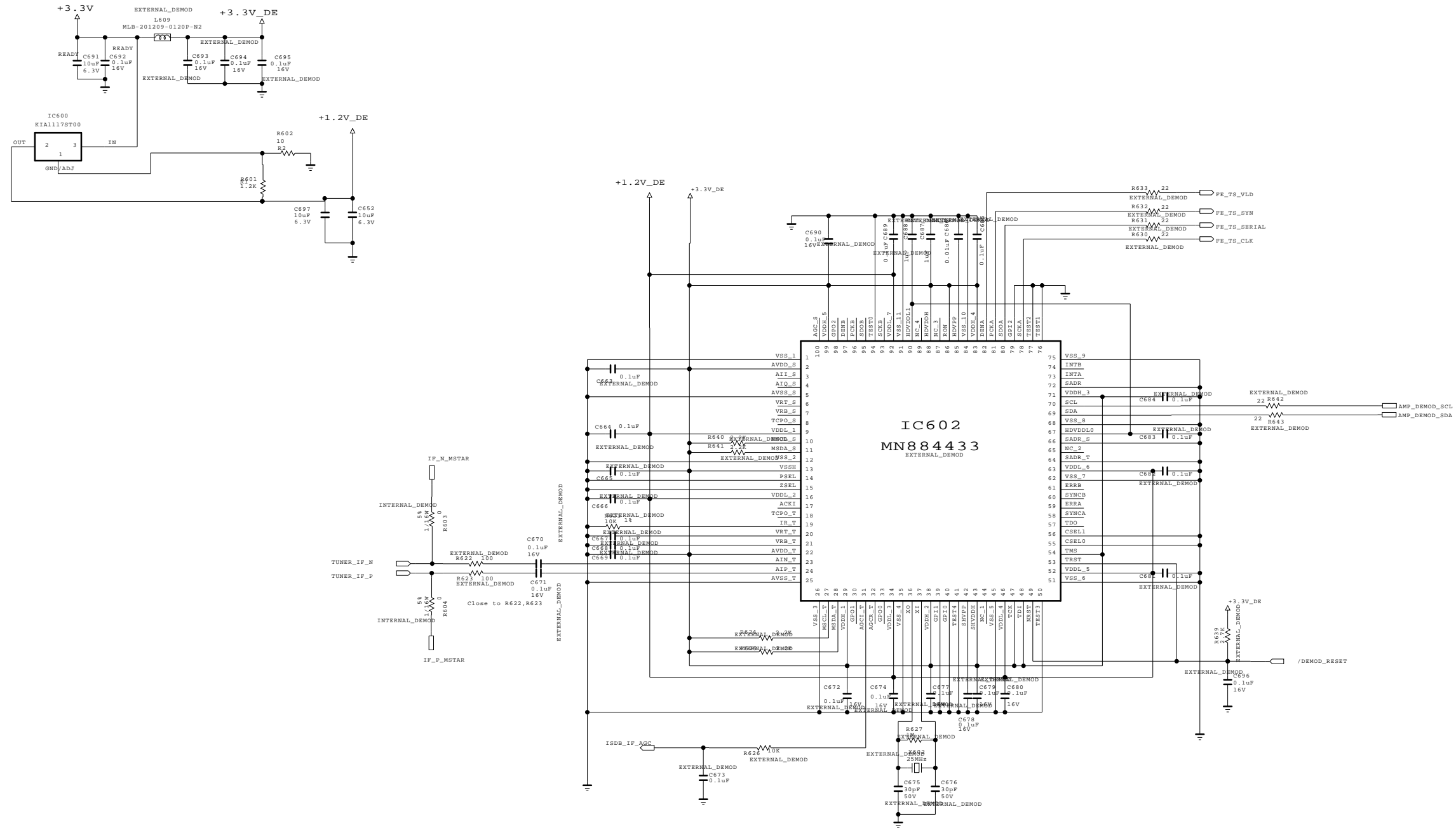

THE SYMBOL MARK OF THIS SCHEMATIC DIAGRAM INCORPORATES SPECIAL FEATURES IMPORTANT FOR PROTECTION FROM X-RADIATION. FILRE AND ELECTRICAL SHOCK HAZARDS, WHEN SERVICING IF IS ESSENTIAL THAT ONLY MANUFACTURERS SPECIFIED PARTS BE USED FOR THE CRITICAL COMPONENTS IN THE SYMBOL MARK OF THE SCHEMATIC.

**SECRET**  
LGElectronics



MODEL	EAX63425902 (5)	DATE	2010.10.21
BLOCK	BRAZIL DEMODULATOR	SHEET	6 / 14

# ST Audio AMP

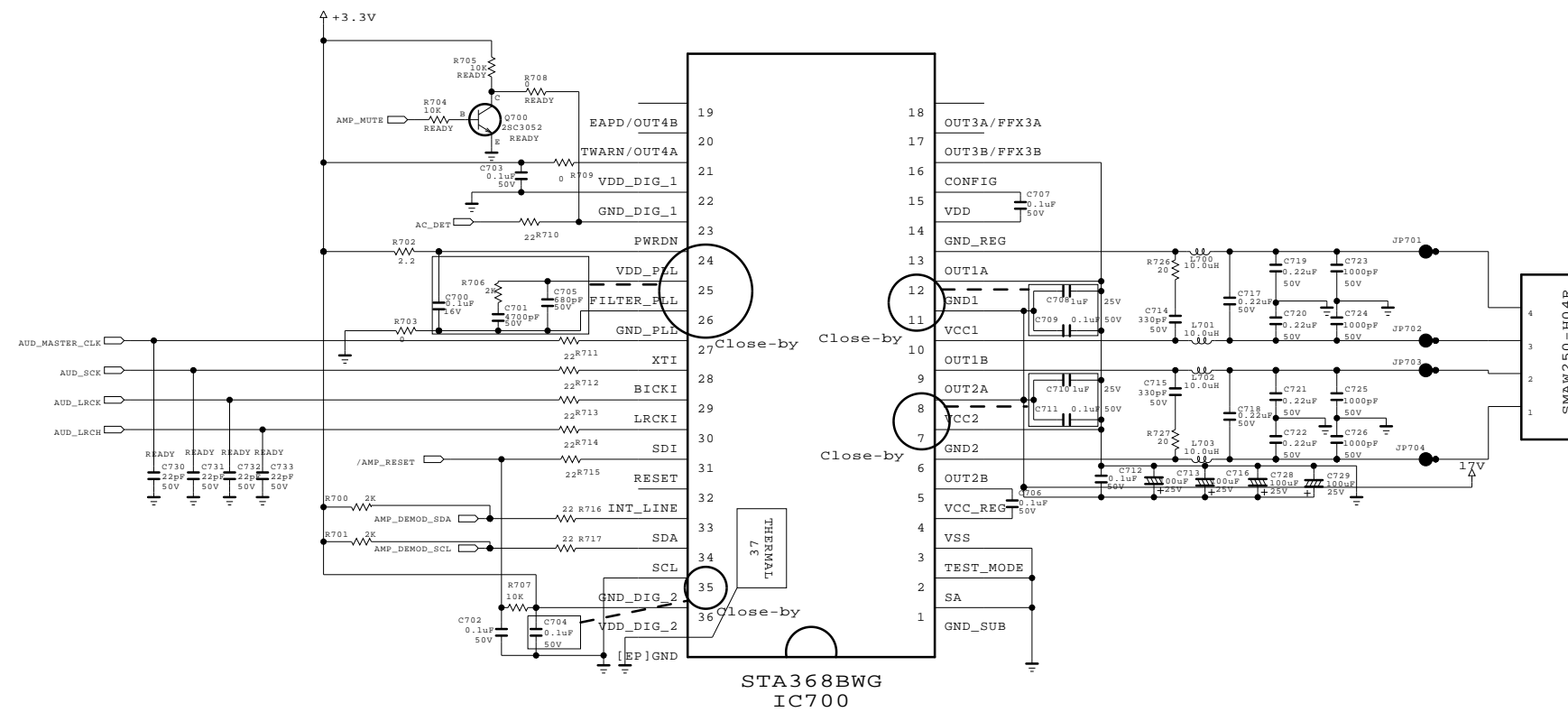

THE SYMBOL MARK OF THIS SCHEMATIC DIAGRAM INCORPORATES SPECIAL FEATURES IMPORTANT FOR PROTECTION FROM X-RADIATION. FILRE AND ELECTRICAL SHOCK HAZARDS, WHEN SERVICING IF IS ESSENTIAL THAT ONLY MANUFACTURES SPECIFIED PARTS BE USED FOR THE CRITICAL COMPONENTS IN THE SYMBOL MARK OF THE SCHEMATIC.

**SECRET**  
LGElectronics



MODEL	EAX63425902 (5)	DATE	2010.10.21
BLOCK	AUDIO AMP	SHEET	7 / 14

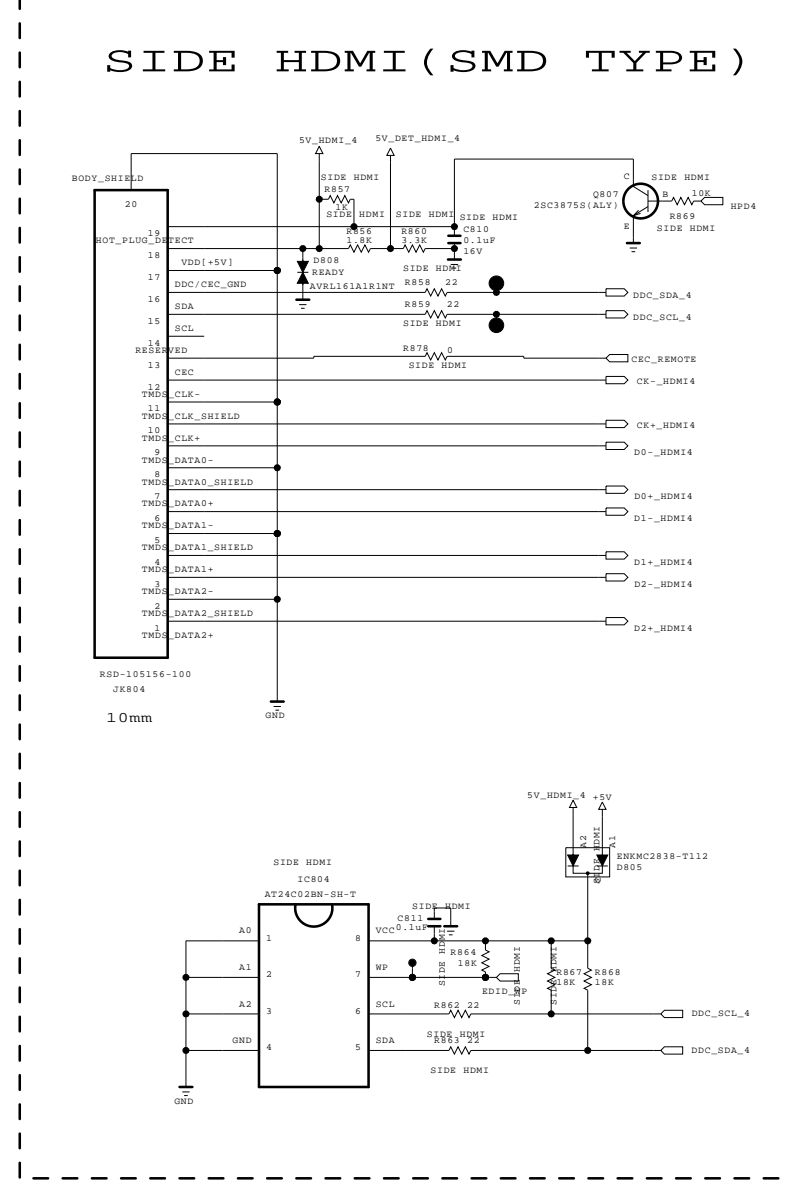
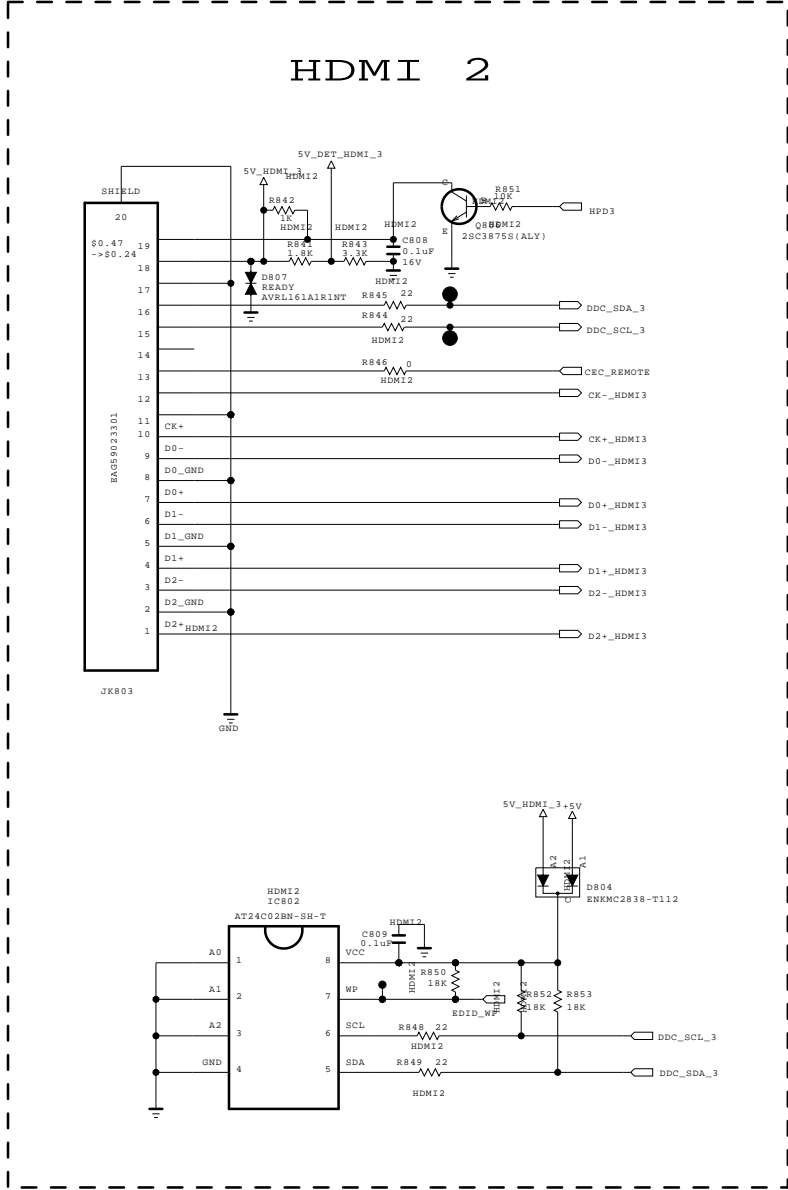
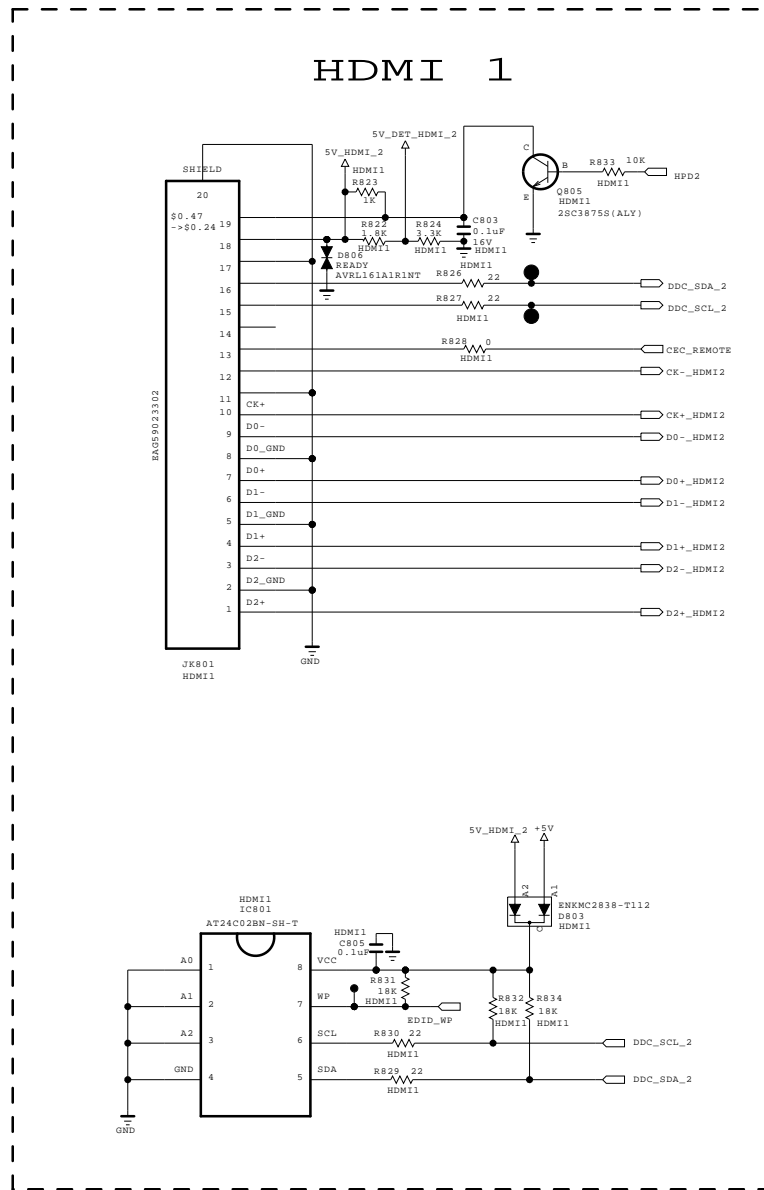
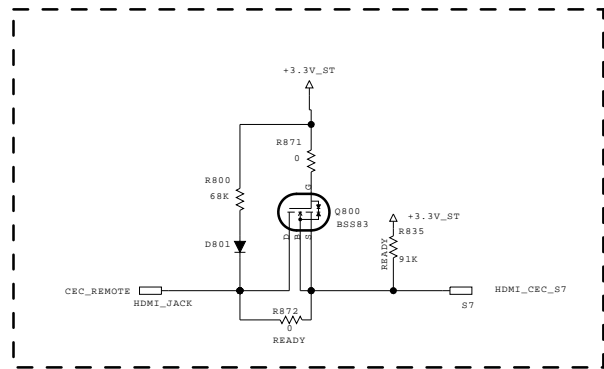

THE SYMBOL MARK OF THIS SCHEMATIC DIAGRAM INCORPORATES SPECIAL FEATURES IMPORTANT FOR PROTECTION FROM X-RADIATION. FILRE AND ELECTRICAL SHOCK HAZARDS, WHEN SERVICING IF IS ESSENTIAL THAT ONLY MANUFACTURES SPECIFIED PARTS BE USED FOR THE CRITICAL COMPONENTS IN THE SYMBOL MARK OF THE SCHEMATIC.

**SECRET**  
LGElectronics



MODEL	EAX63425902 (5)	DATE	2010.10.21
BLOCK	HDMI	SHEET	8 / 14

### RGB

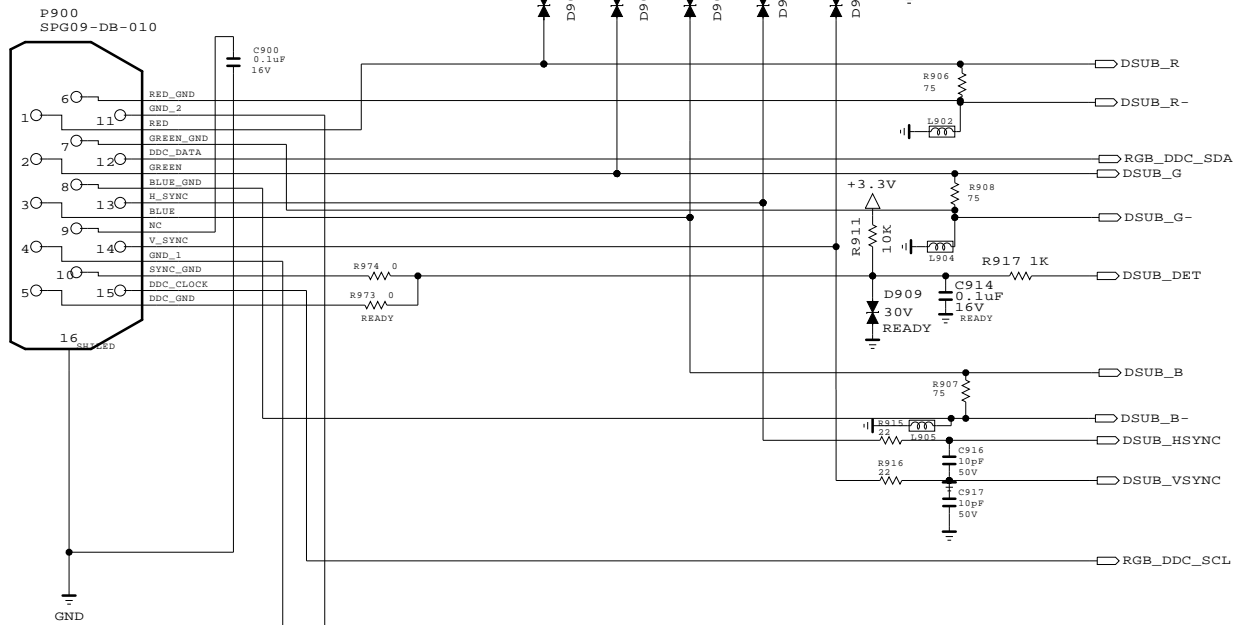

### SUB Board I/F

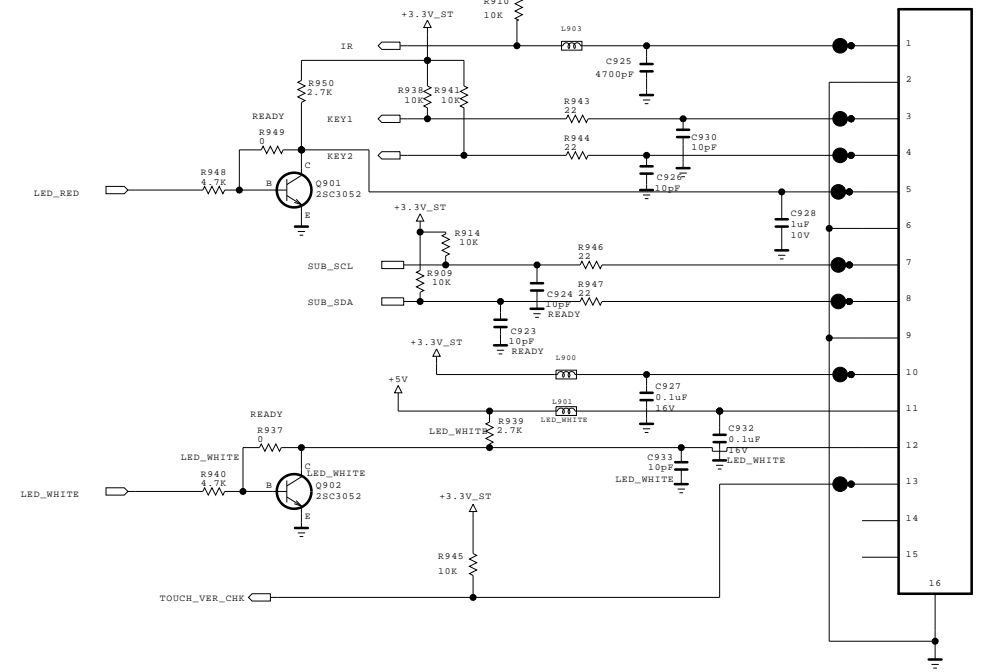

### ROM DOWNLOAD FOR PDP

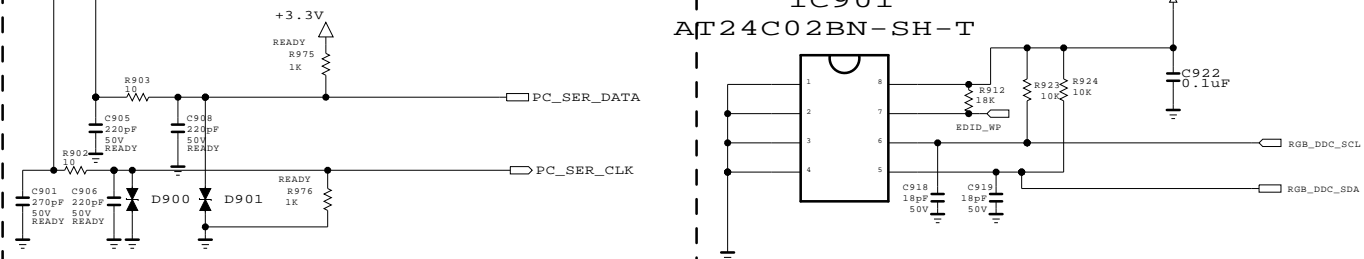

### For RGB Debugging

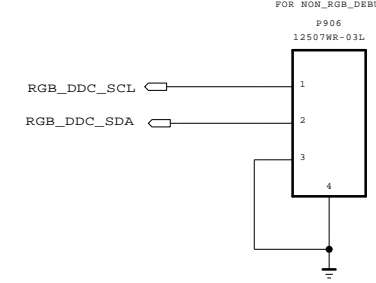

### RS232C

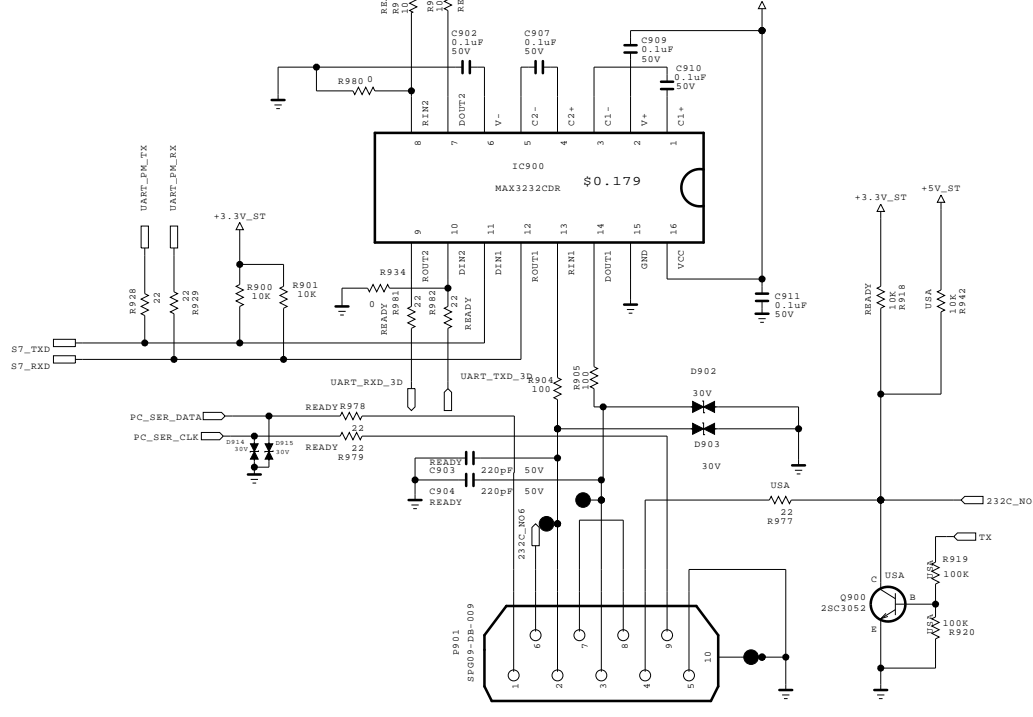

### PC AUDIO

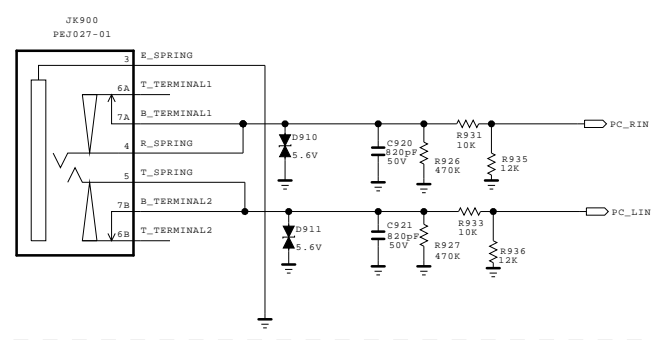

### USA IR JACK

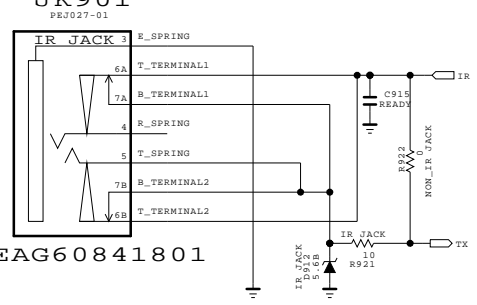

### SCREW GND Separate

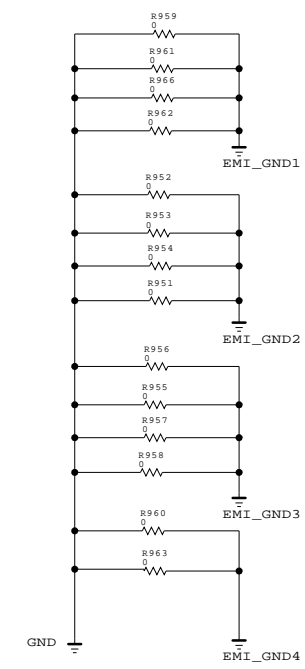

### IR Wafer/ SIDE\_HDMI/USB GASKET GND

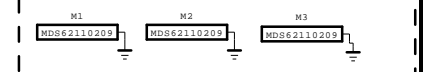

THE SYMBOL MARK OF THIS SCHEMATIC DIAGRAM INCORPORATES SPECIAL FEATURES IMPORTANT FOR PROTECTION FROM X-RADIATION. FILRE AND ELECTRICAL SHOCK HAZARDS, WHEN SERVICING IF IS ESSENTIAL THAT ONLY MANUFACTURES SPECIFIED PARTS BE USED FOR THE CRITICAL COMPONENTS IN THE SYMBOL MARK OF THE SCHEMATIC.

**SECRET**  
LGElectronics



MODEL	EAX63425902(5)	DATE	2010.10.21
BLOCK	RGB/RS232/PC/USA IR SUB IR	SHEET	9 / 14

JK1000  
PPJ239-01

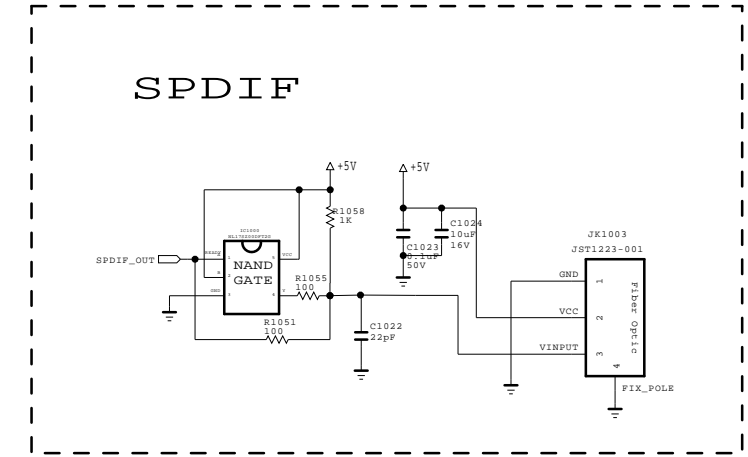
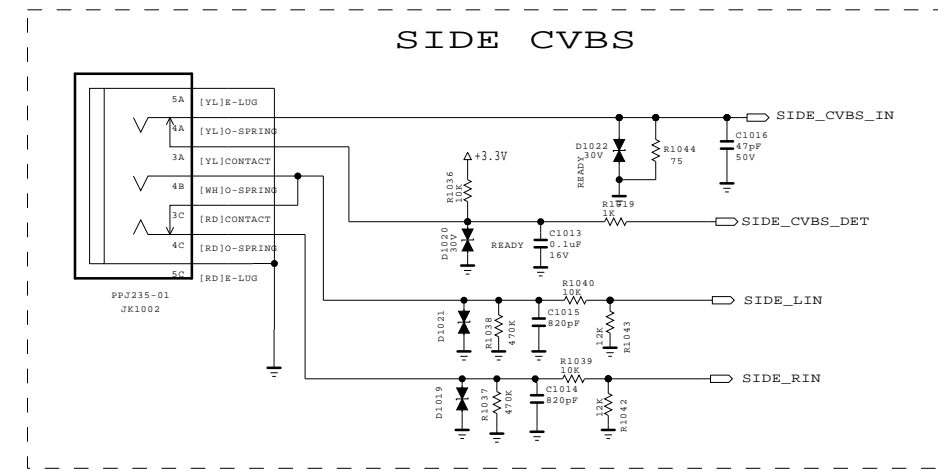
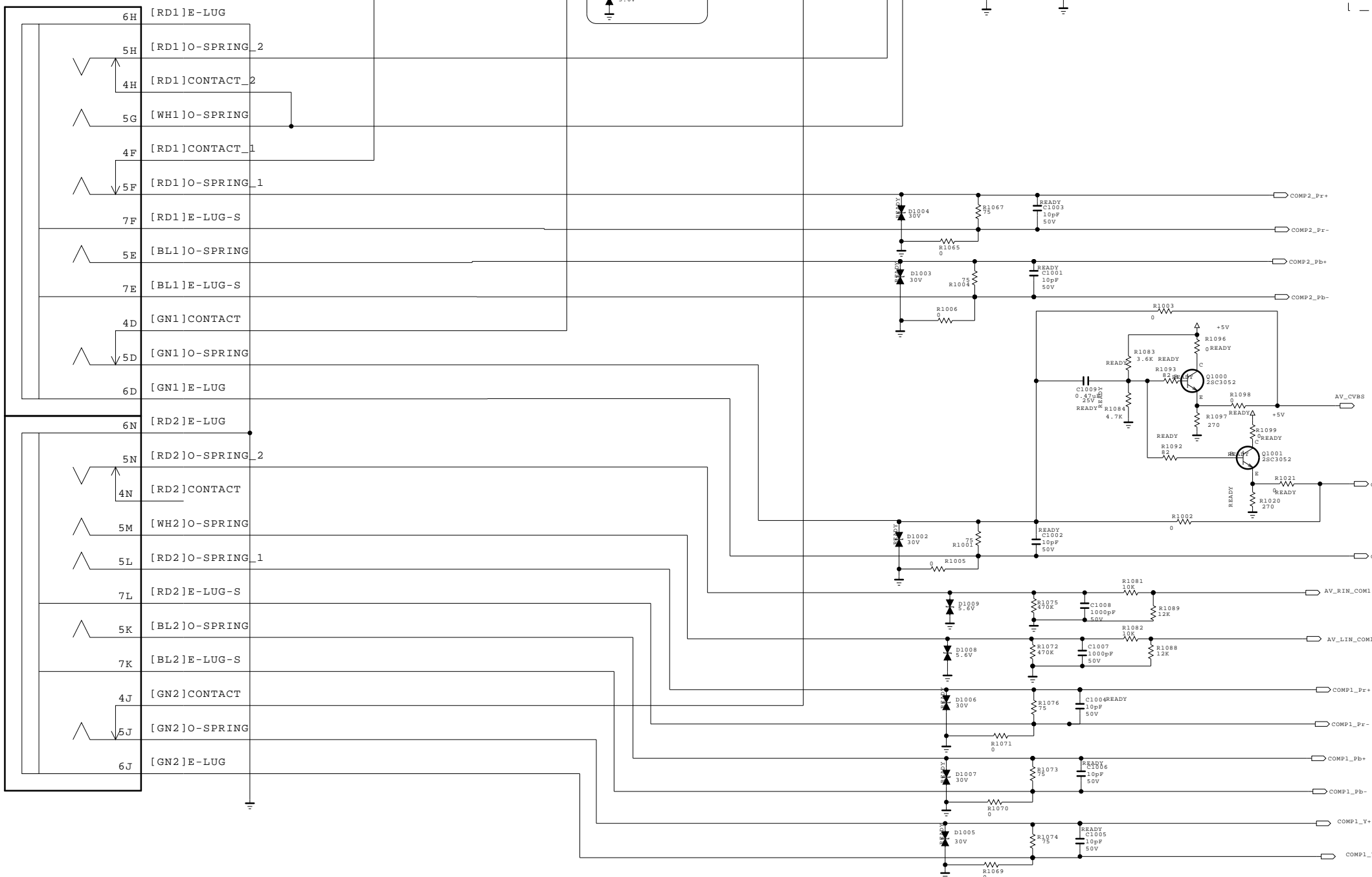

COMP1_DET	AV_CVBS_DET	RESULT
HIGH	HIGH	COMP1_DET
HIGH	LOW	AV_CVBS
LOW	HIGH	
LOW	LOW	

THE  $\Delta$  SYMBOL MARK OF THIS SCHEMATIC DIAGRAM INCORPORATES SPECIAL FEATURES IMPORTANT FOR PROTECTION FROM X-RADIATION. FILRE AND ELECTRICAL SHOCK HAZARDS, WHEN SERVICING IF IS ESSENTIAL THAT ONLY MANUFACTURES SPECIFIED PARTS BE USED FOR THE CRITICAL COMPONENTS IN THE  $\Delta$  SYMBOL MARK OF THE SCHEMATIC.

SECRET  
LGElectronics



MODEL	EAX63425902(5)	DATE	2010.10.21
BLOCK	CVBS/COM1/2 JACK	SHEET	10 / 14

### USB1 SIDE

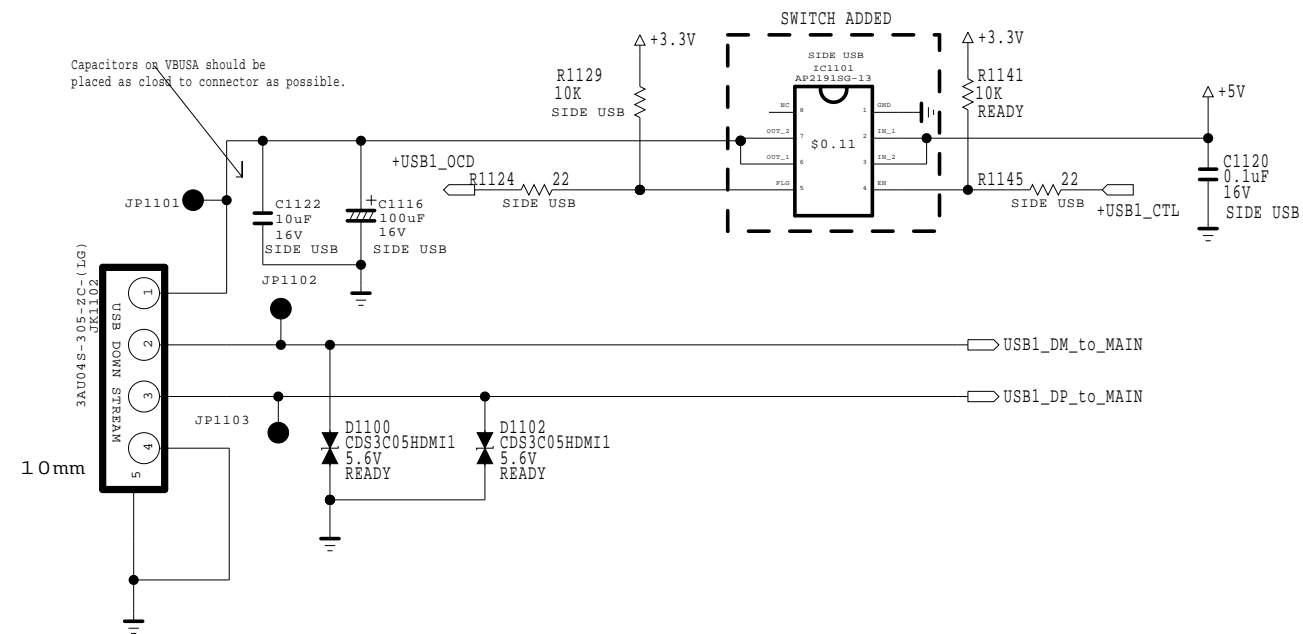

### USB2 REAR (SVC)

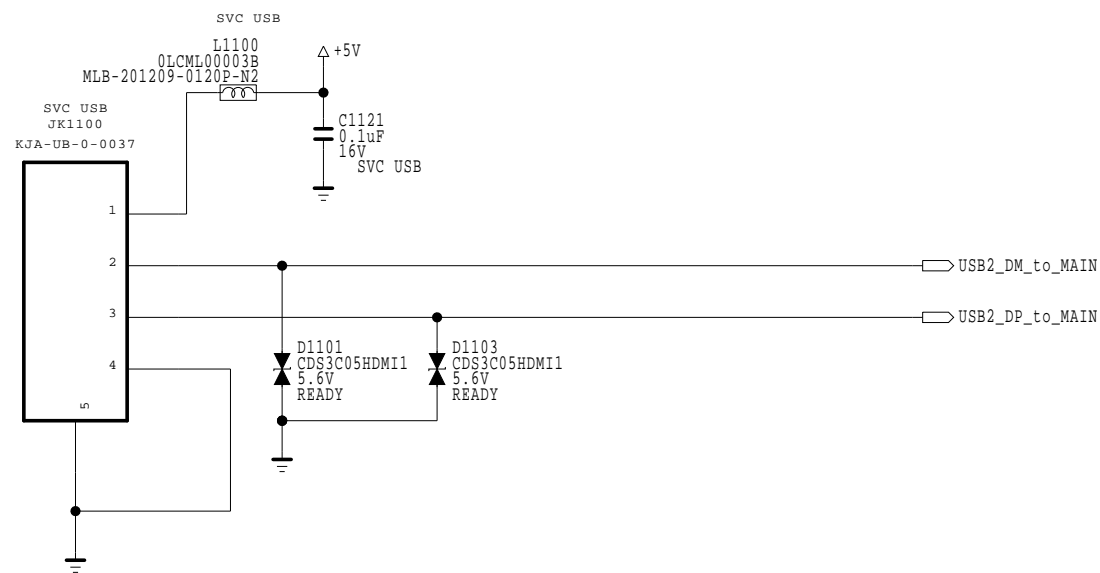

THE SYMBOL MARK OF THIS SCHEMATIC DIAGRAM INCORPORATES SPECIAL FEATURES IMPORTANT FOR PROTECTION FROM X-RADIATION. FILRE AND ELECTRICAL SHOCK HAZARDS, WHEN SERVICING IF IS ESSENTIAL THAT ONLY MANUFACTURES SPECIFIED PARTS BE USED FOR THE CRITICAL COMPONENTS IN THE SYMBOL MARK OF THE SCHEMATIC.

SECRET	LG ELECTRONICS
LGElectronics	

MODEL	EAX63425902(3)	DATE	2010.10.21
BLOCK	SIDE / SVC USB	SHEET	11 / 14



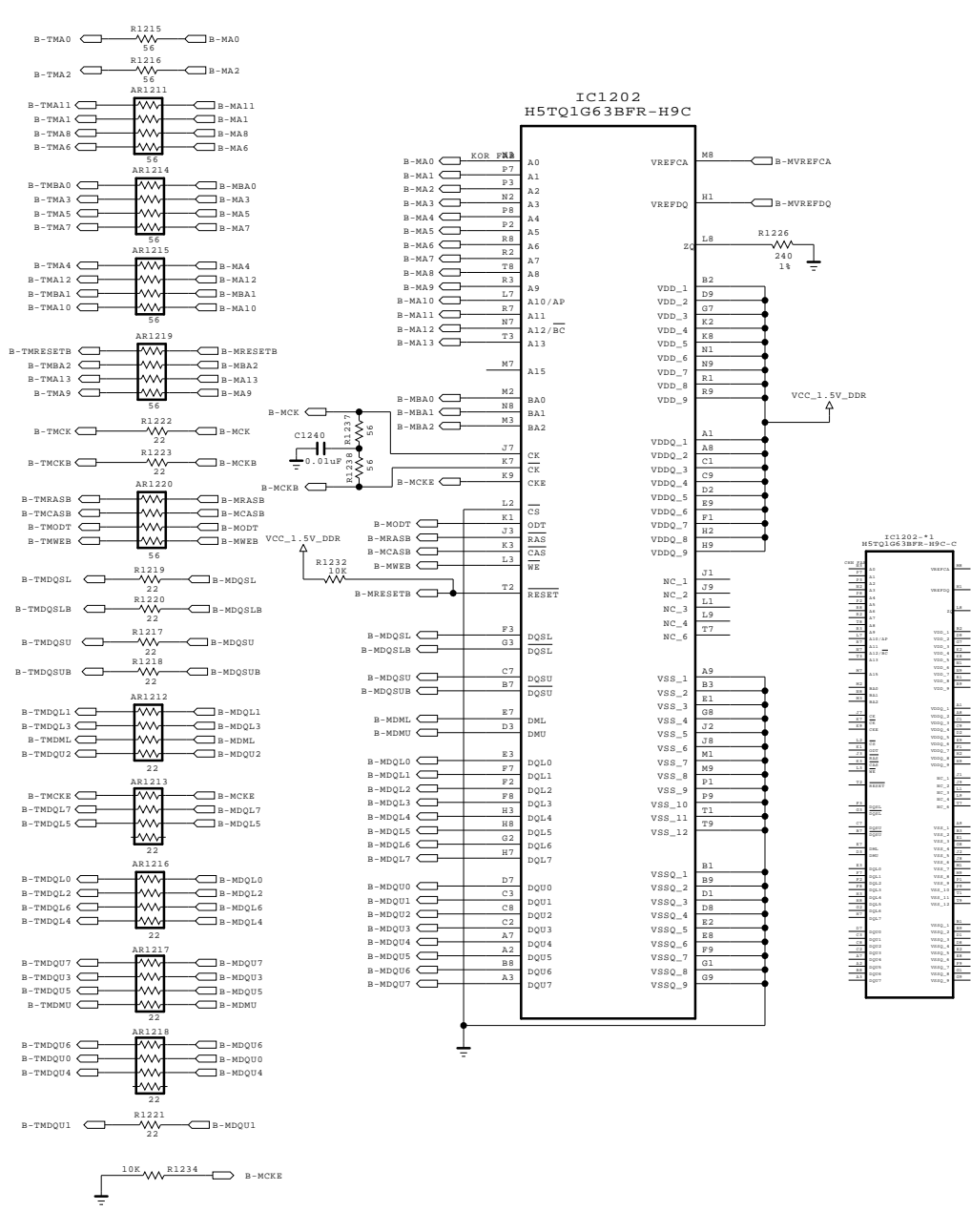
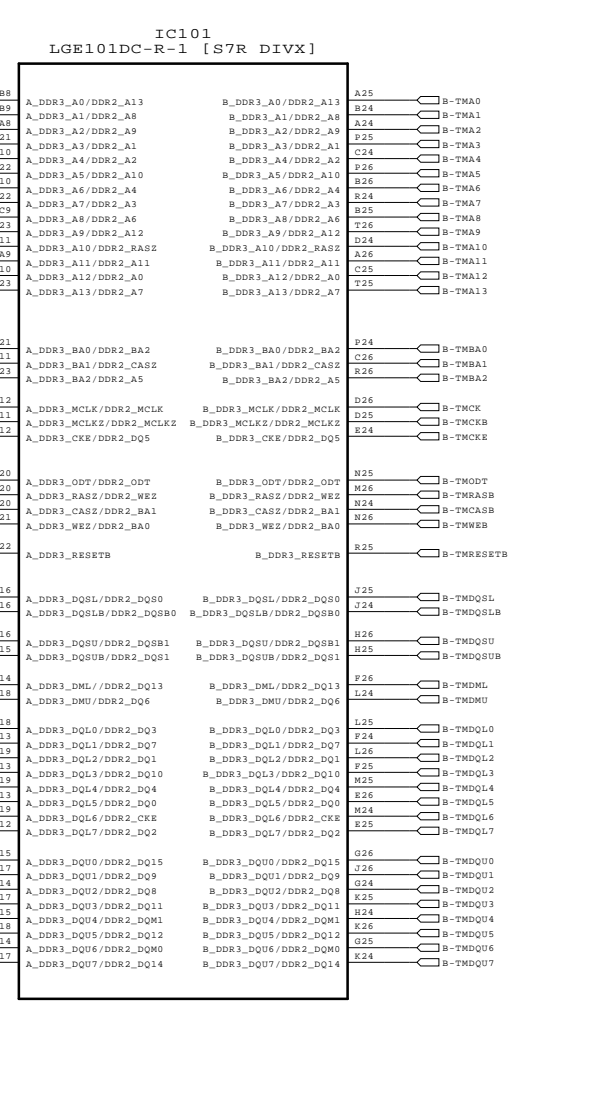
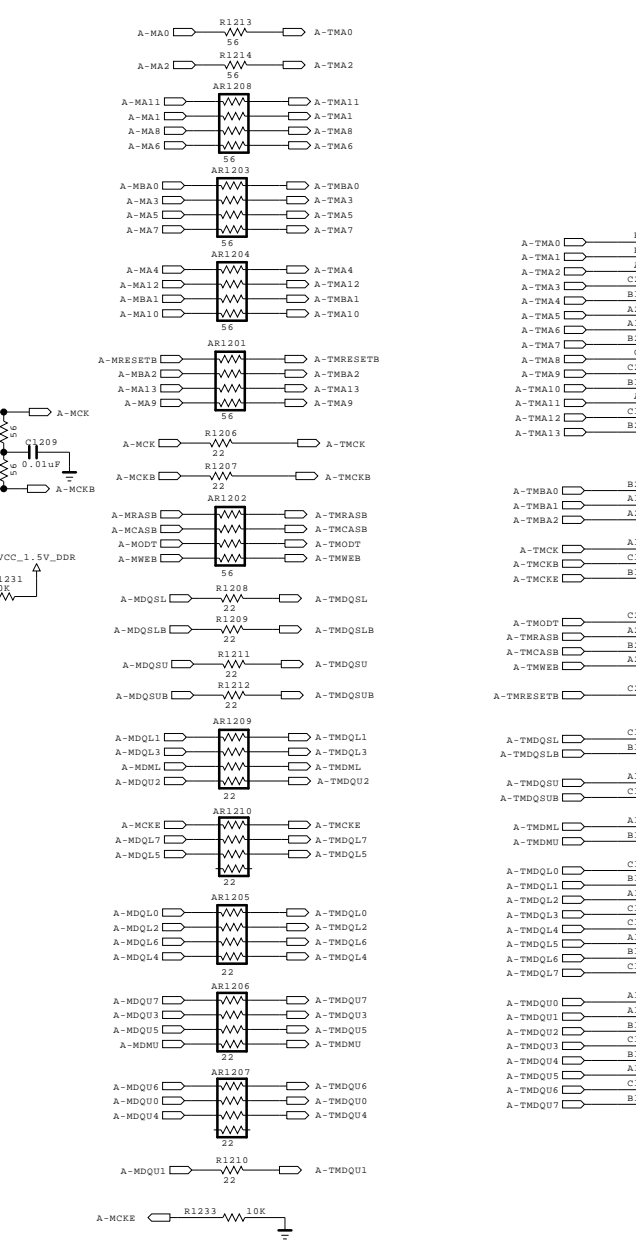
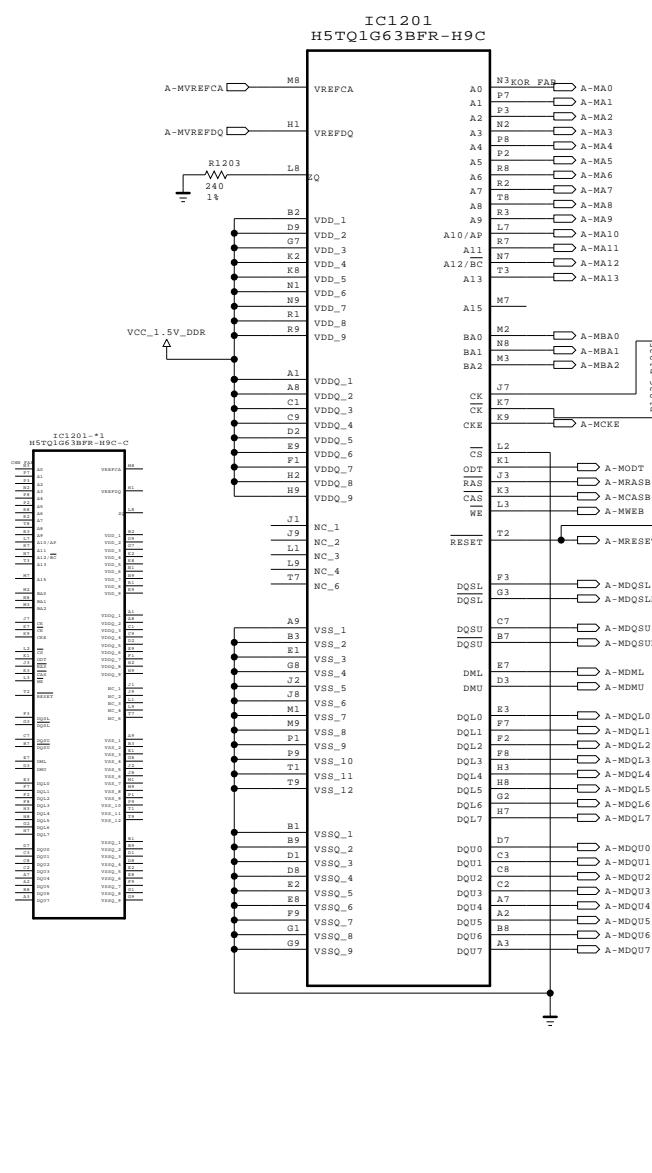
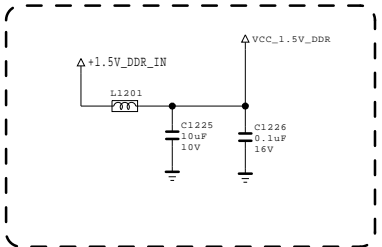
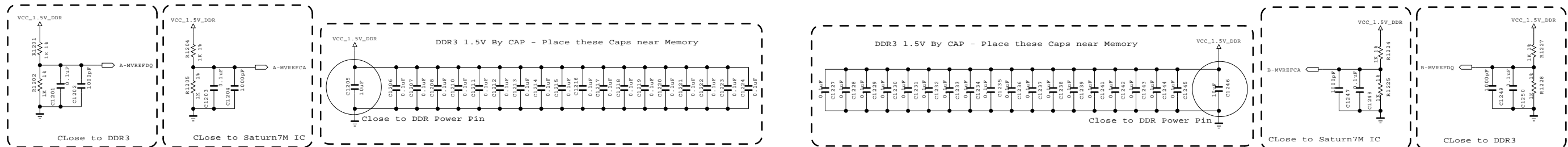

THE SYMBOL MARK OF THIS SCHEMATIC DIAGRAM INCORPORATES SPECIAL FEATURES IMPORTANT FOR PROTECTION FROM X-RADIATION. FILRE AND ELECTRICAL SHOCK HAZARDS, WHEN SERVICING IF IS ESSENTIAL THAT ONLY MANUFACTURES SPECIFIED PARTS BE USED FOR THE CRITICAL COMPONENTS IN THE SYMBOL MARK OF THE SCHEMATIC.

**SECRET**  
LGElectronics

LG ELECTRONICS

MODEL	EAX63425902(5)	DATE	2010.10.21
BLOCK	DDR	SHEET	12 / 14

# < KOREA / BRAZIL TUNER >

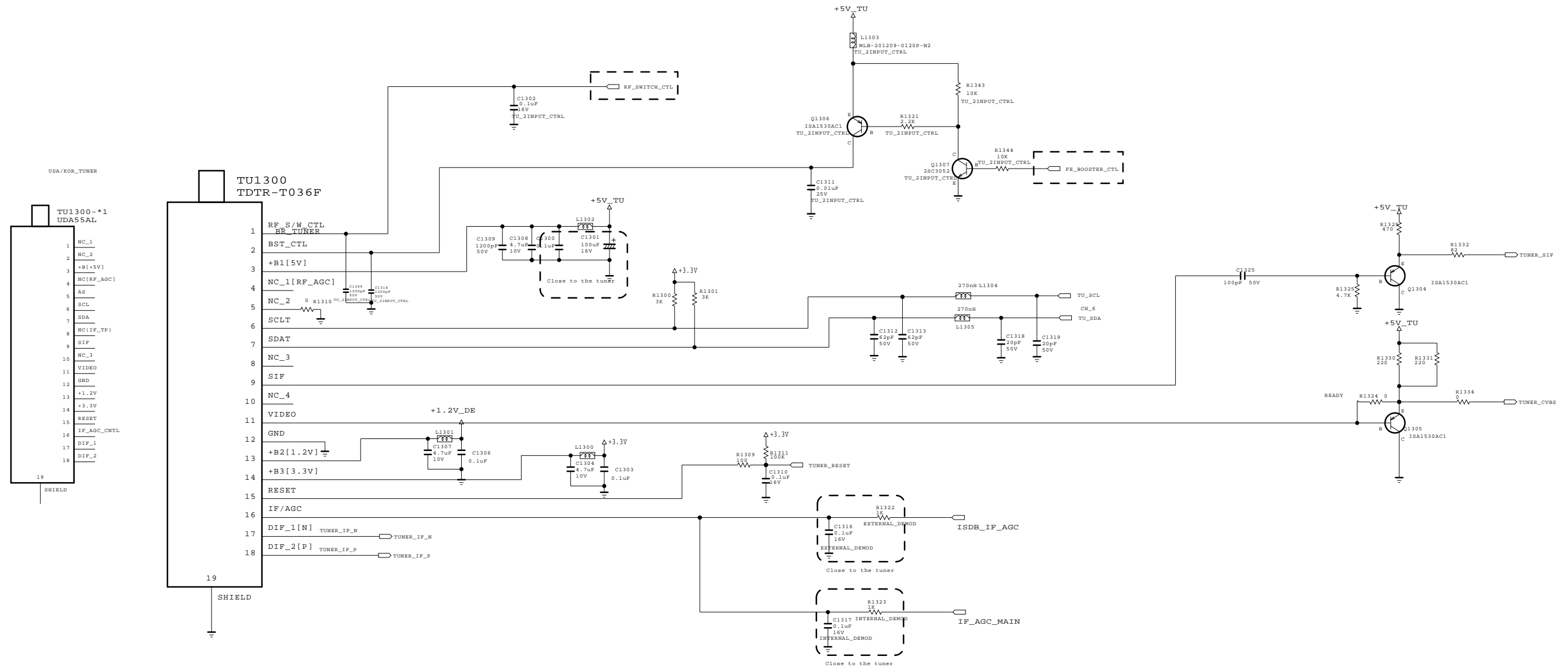

THE SYMBOL MARK OF THIS SCHEMATIC DIAGRAM INCORPORATES SPECIAL FEATURES IMPORTANT FOR PROTECTION FROM X-RADIATION. FILRE AND ELECTRICAL SHOCK HAZARDS, WHEN SERVICING IF IS ESSENTIAL THAT ONLY MANUFACTURES SPECIFIED PARTS BE USED FOR THE CRITICAL COMPONENTS IN THE SYMBOL MARK OF THE SCHEMATIC.

SECRET  
LGElectronics



MODEL	EAX63425902(5)	DATE	2010.10.21
BLOCK	KOREA/BRAZIL CAN TUNER	SHEET	13 / 14

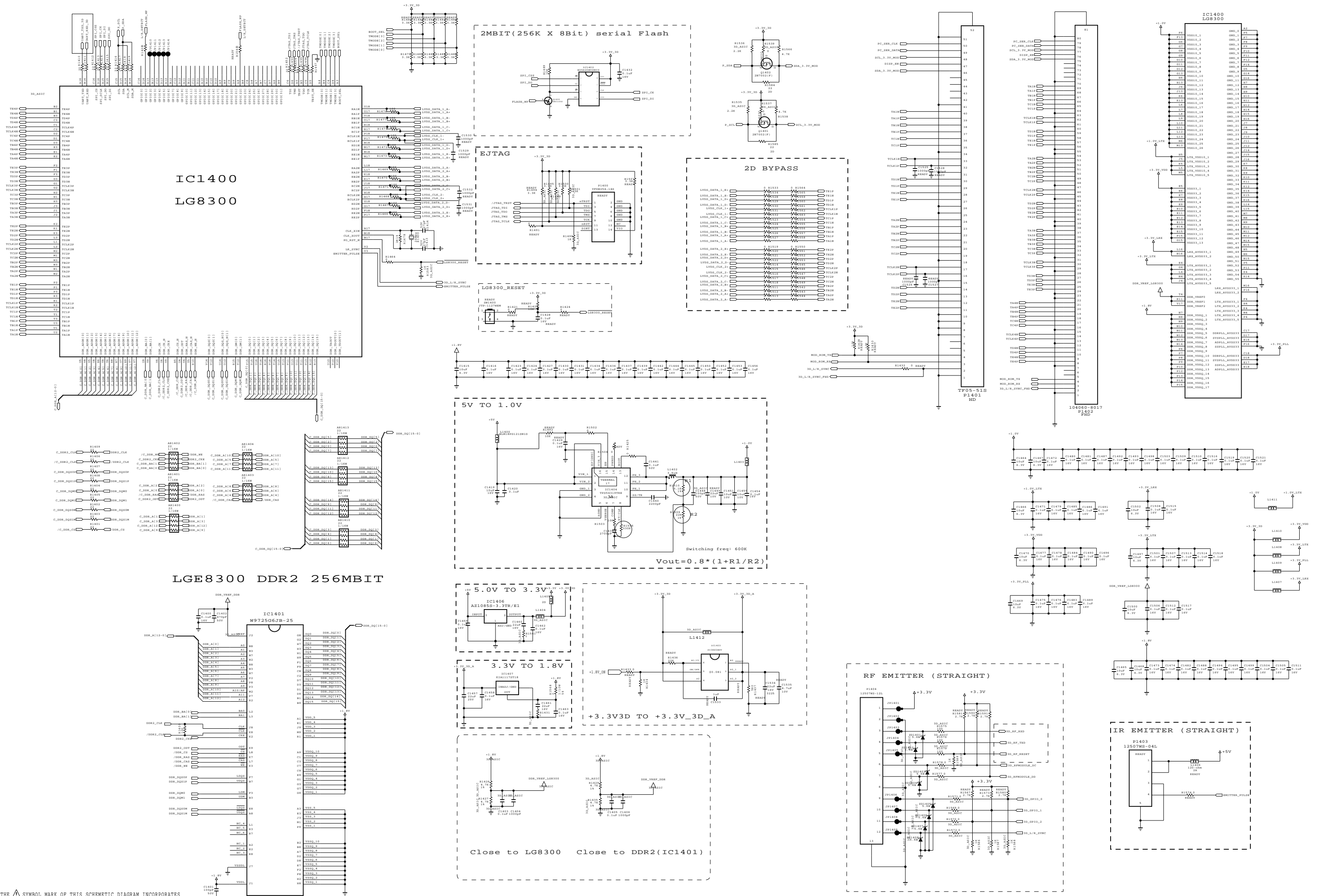

THE  $\Delta$  SYMBOL MARK OF THIS SCHEMATIC DIAGRAM INCORPORATES SPECIAL FEATURES IMPORTANT FOR PROTECTION FROM X-RADIATION. FILTRATION AND ELECTRICAL SHOCK HAZARDS, WHEN SERVICING IT IS ESSENTIAL THAT ONLY MANUFACTURERS SPECIFIED PARTS BE USED FOR THE CRITICAL COMPONENTS IN THE  $\Delta$  SYMBOL MARK OF THE SCHEMATIC.

SECRET  
LGElectronics

LG ELECTRONICS

MODEL	EAX63425902(5)	DATE	2010.10.21
BLOCK	3DF	SHEET	14 / 14



*Great Company Great People*

***Think New***

***ERRC*** *Eliminate, Reduce,  
Raise, Create*

## GP2-R Training manual

### Contents

- Block Diagram
- System Design
- Trouble Shooting Guide



ATSC Group GP2-R Team

# Block Diagram – Overview()

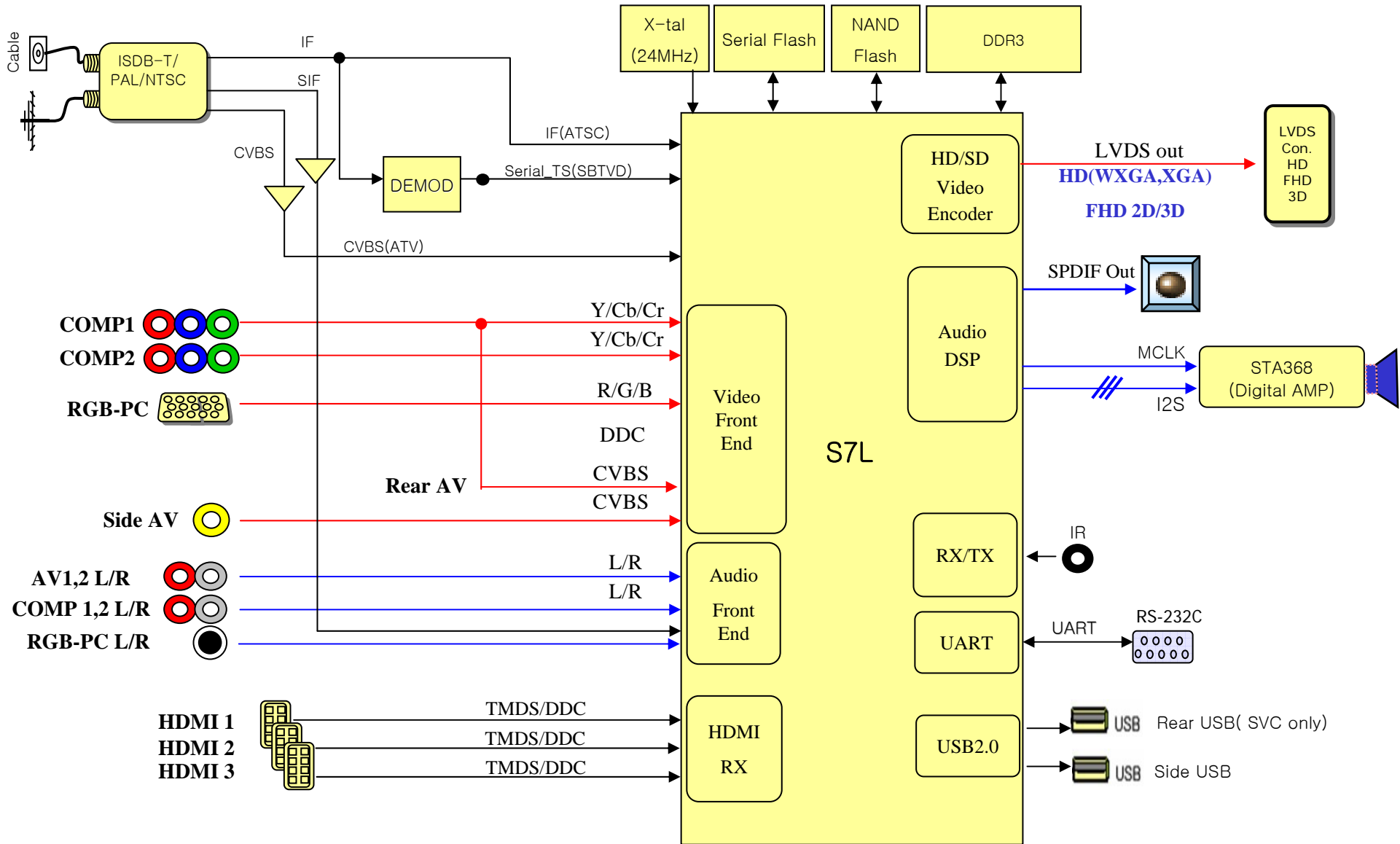

# 1. Power-Up Boot Fail Trouble Shooting

(Front-end)

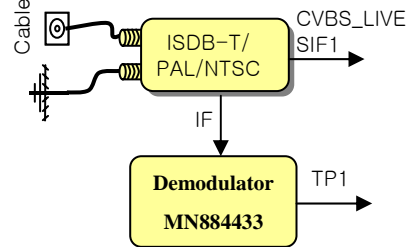

(System + Scalar)

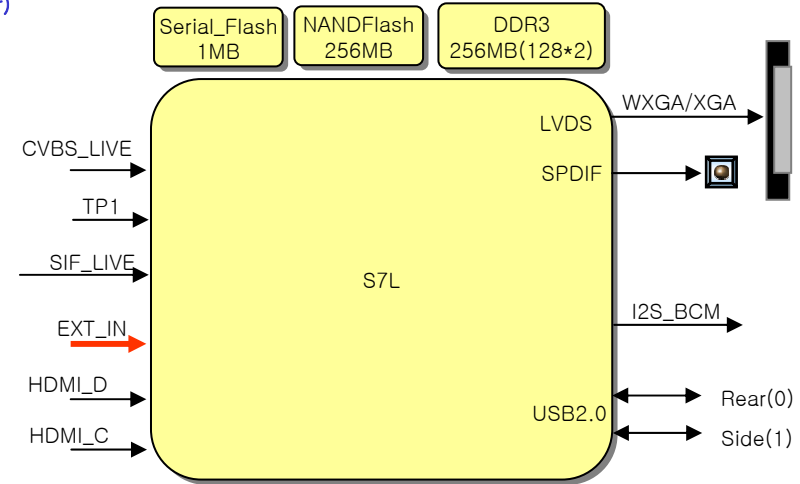

(External Input)

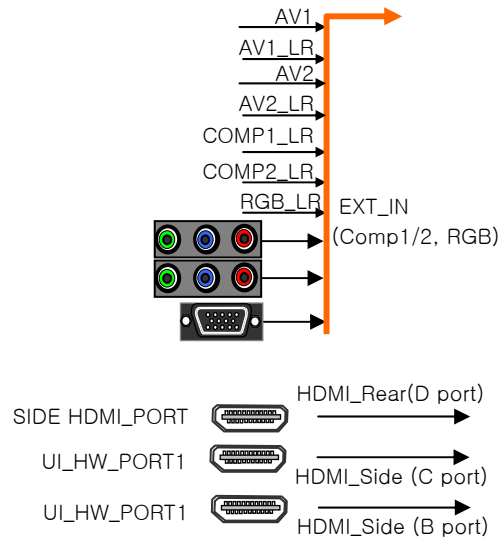

(Audio Out)

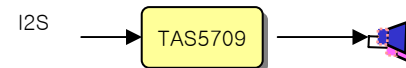

(USB)



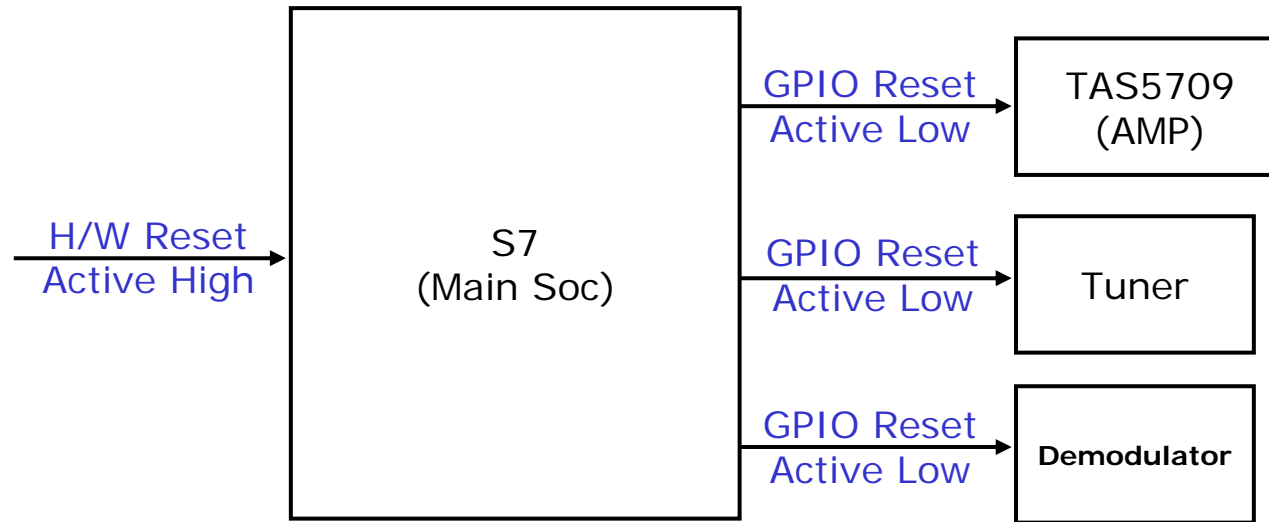



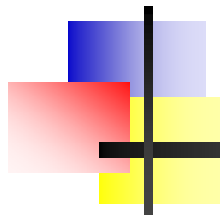

## Power Up Sequence

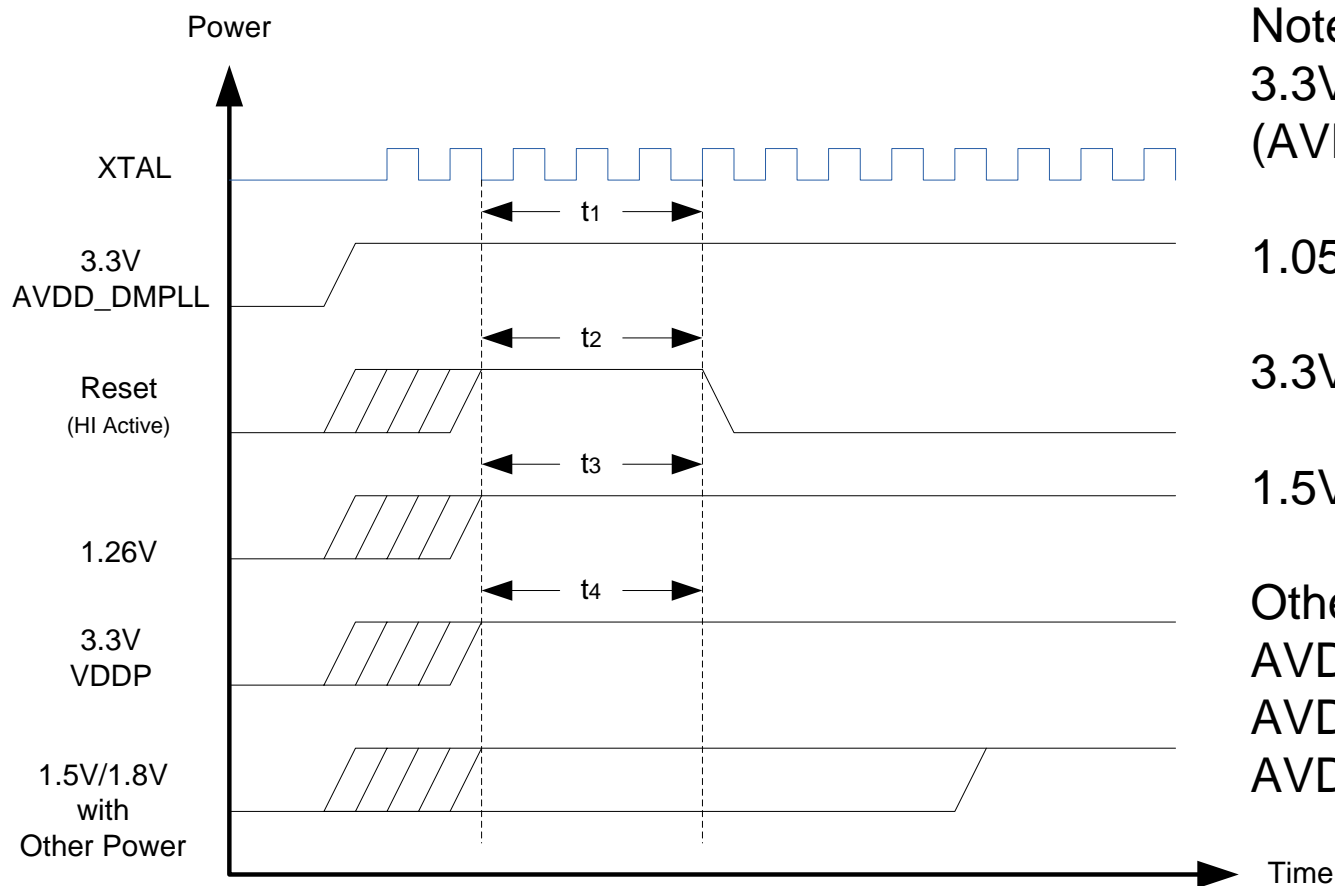

Note:  
 3.3V\_AVDD\_MPLL  
 (AVDD\_DMPLL)  
 1.05V (VDDC)  
 3.3V\_VDDP (VDDP)  
 1.5V/1.8V (AVDD\_DDR0/1)  
 Other Power (AVDD\_AU25,  
 AVDD\_AU33,  
 AVDD\_MEMPLL,  
 AVDD2P5\_ADC...etc)

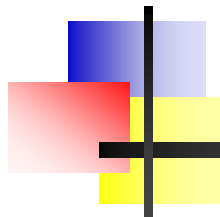

## ◆ Power Up Timing Requirements

Time	Description	Min	Typ.	Max	Unit
$t_1$	XTAL stable to Reset falling	5	—	—	ms
$t_2$	Reset pulse width	5	—	—	ms
$t_3$	1.26V to Reset falling	5	—	—	ms
$t_4$	3.3VDDP to Reset falling	5	—	—	ms

# t2 : Reset Pulse Width : 40ms → OK

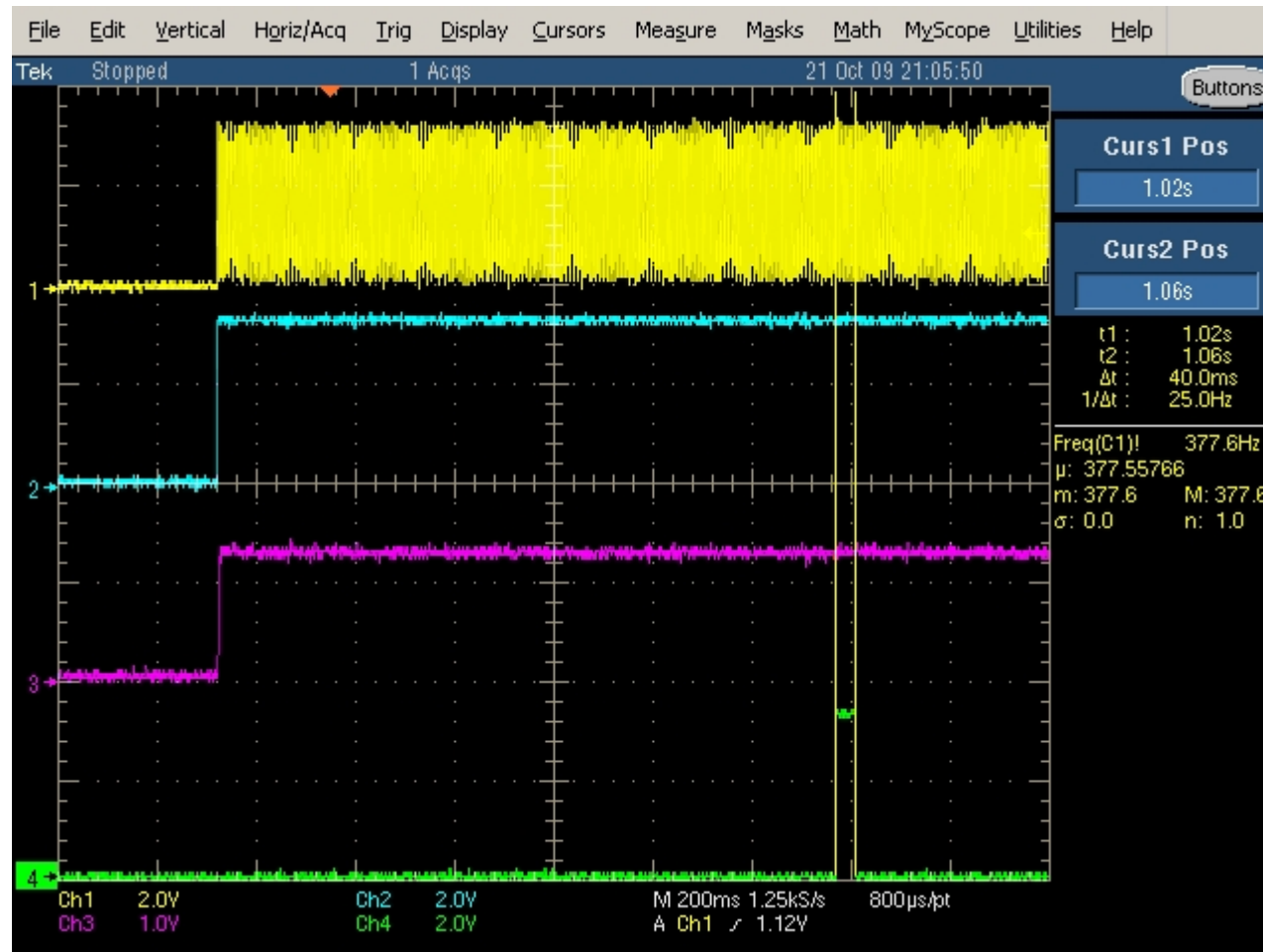

## a) AC On

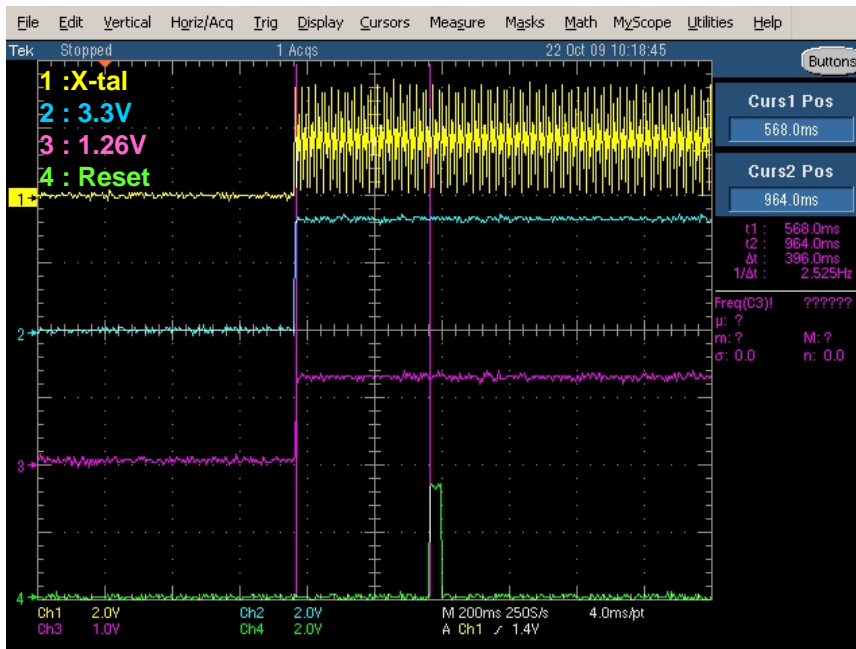

- # t1 : Reset Pulse Width : 400ms → OK
- # t3 : Reset Pulse Width : 400ms → OK
- # t4 : Reset Pulse Width : 400ms → OK

## b) DC(Remocon) On

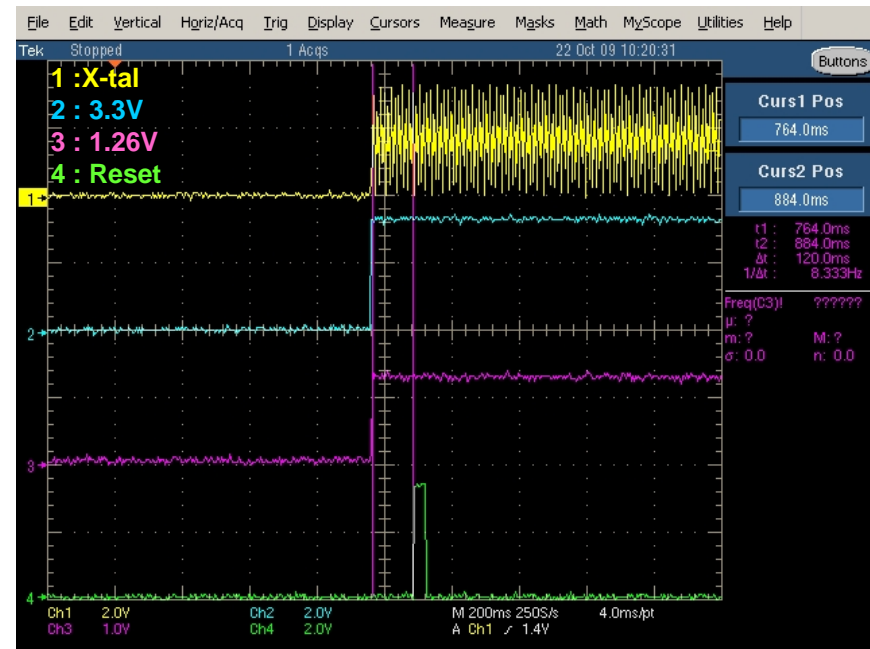

- # t1 : Reset Pulse Width : 120ms → OK
- # t3 : Reset Pulse Width : 120ms → OK
- # t4 : Reset Pulse Width : 120ms → OK

# GP2-R I2C MAP

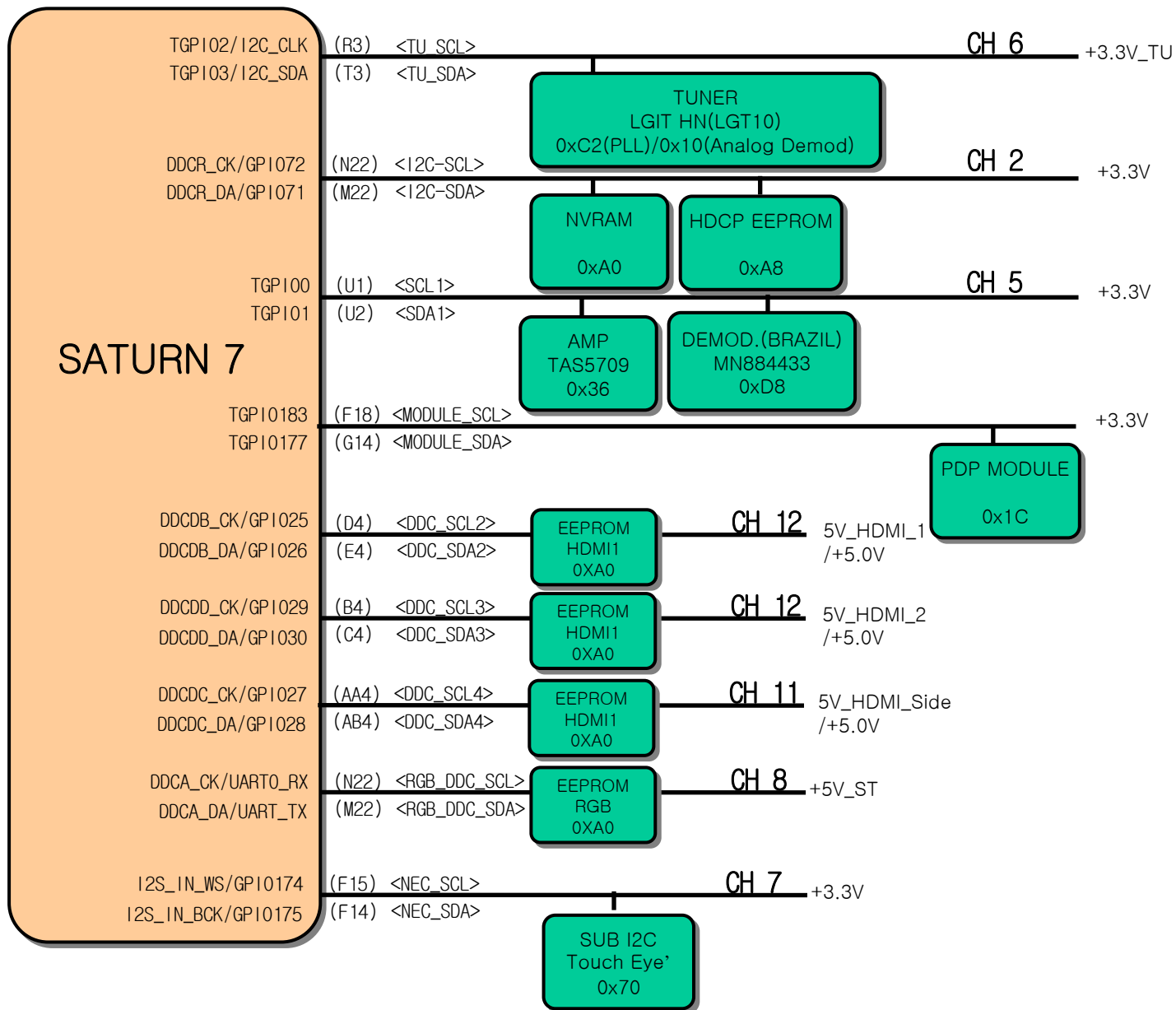

GPIO	Signal Name	Direction	Description
66	PWMO	Input	Chip configuration
67	PWM1	Input	Chip configuration
31	DSUB_DET	Input	D-Sub Auto link check
32	Model_OPT_3	Input	Model option 3
42	Model_OPT_0	Input	Model option 0
11	Model_OPT_1	Input/Output	Model option 1 /FE_BOOSTER_CTRL
14	Model_OPT_2	Input/Output	Model option 2/RF_SWITCH_CTL
TCON2/GSP_R/GCLK1	5V_DET_HDMI_2	Input	(HDMI 3 Ready) HDMI 5V Detect
TCON4/CPV//GSC_R/GCLK3	5V_DET_HDMI_4	Input	HDMI Side 5V Detect
TCON6/FLK	5V_DET_HDMI_3	Input	HDMI_1 5V Detect
40	COMP1_DET	Input	Component1 Auto link
50	MOD_ROM_RX	Input	Module Rom download UART
51	MOD_ROM_TX	Output	Module Rom download UART
5	USB1_OCD	input	USB1_OCD
7	USB1_CTRL	Output	USB1_5V Power Control
15	TUNER_RESET	Output	TUNER_RESET
16	DEMOD_RESET	Output	Demodulator Reset
17	AV_CVBS_DET	Input	AV_CVBS Auto link
176	COMP2_DET	Input	Component2 Auto link
TCON8/CS2/FLK3	SIDE_CVBS_DET	Input	SIDE_CVBS Auto link

# GP2-R Power flow

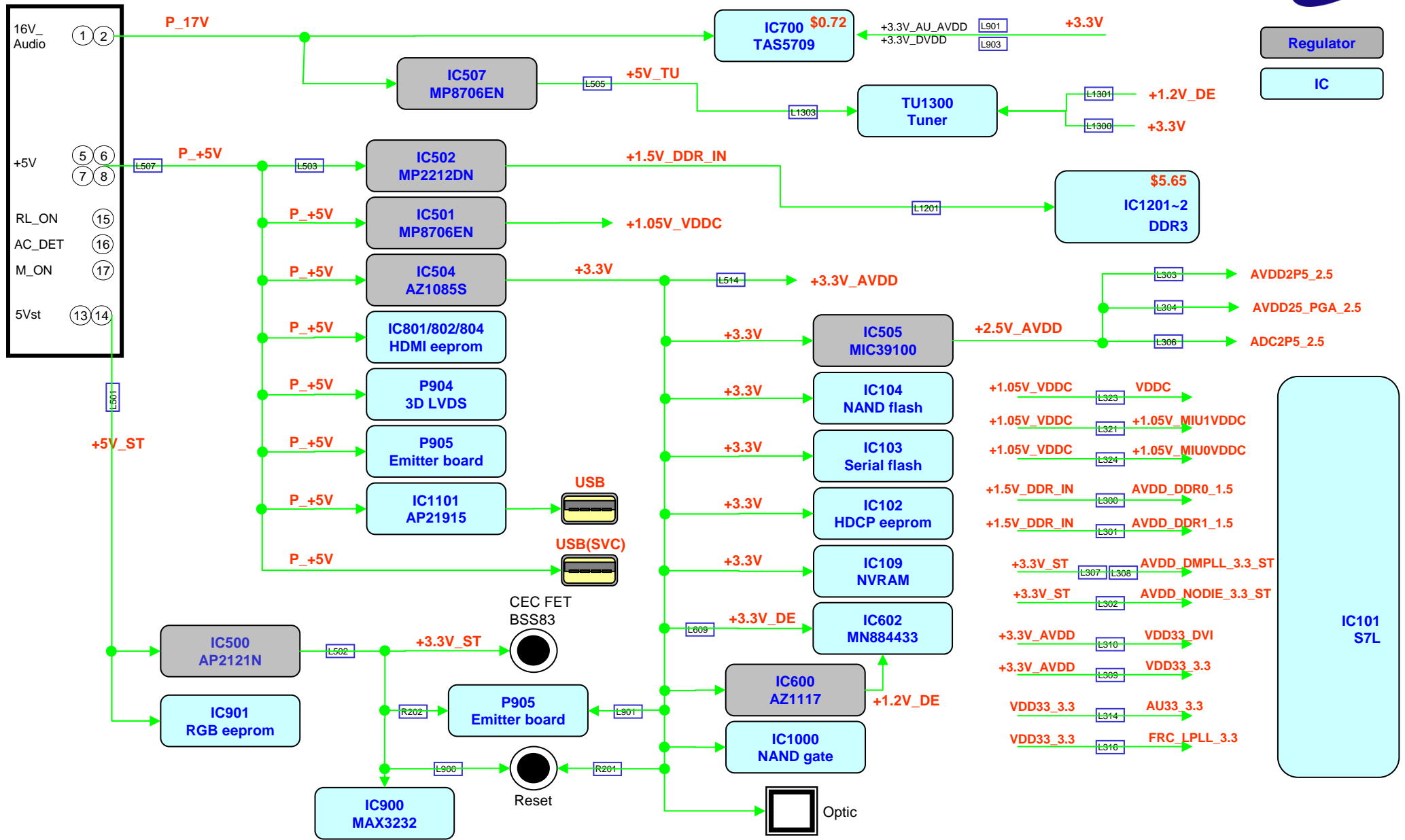

**Please check system, after power Off/On one time**

1. Power-Up Boot Fail Trouble Shooting
2. No OSD Trouble Shooting
3. Digital TV Video Trouble Shooting
4. Analog TV Video Trouble Shooting
5. Component Video Trouble Shooting
6. RGB Video Trouble Shooting
7. AV Video Trouble Shooting
8. HDMI Video Trouble Shooting
9. All Source Audio Trouble Shooting
10. Digital TV Audio Trouble Shooting
11. Analog TV Audio Trouble Shooting
12. Component / RGB / AV Audio Trouble Shooting
13. HDMI Audio Trouble Shooting
14. USB Trouble Shooting



# 1. Power-Up Boot Fail Trouble Shooting

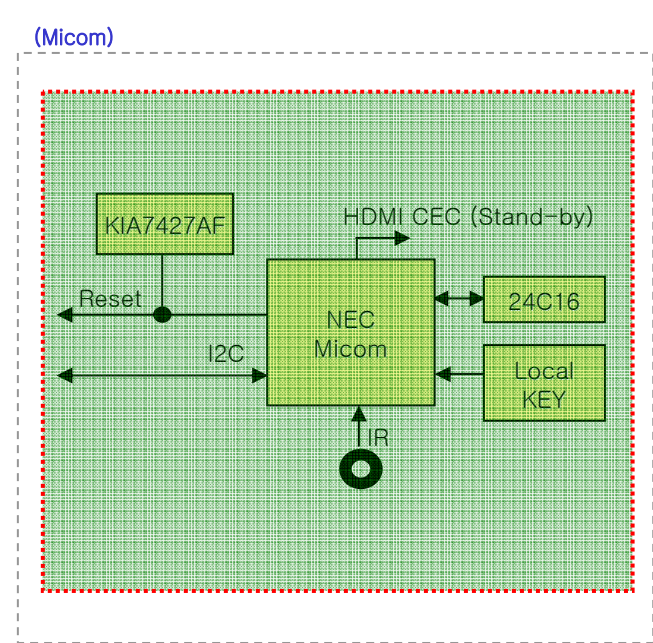
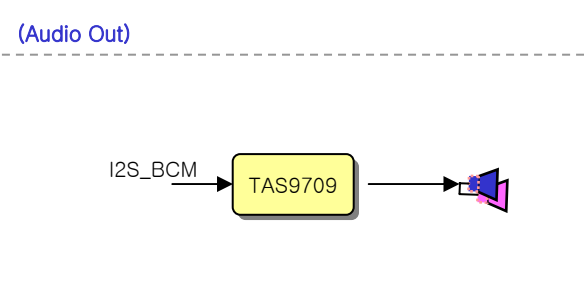
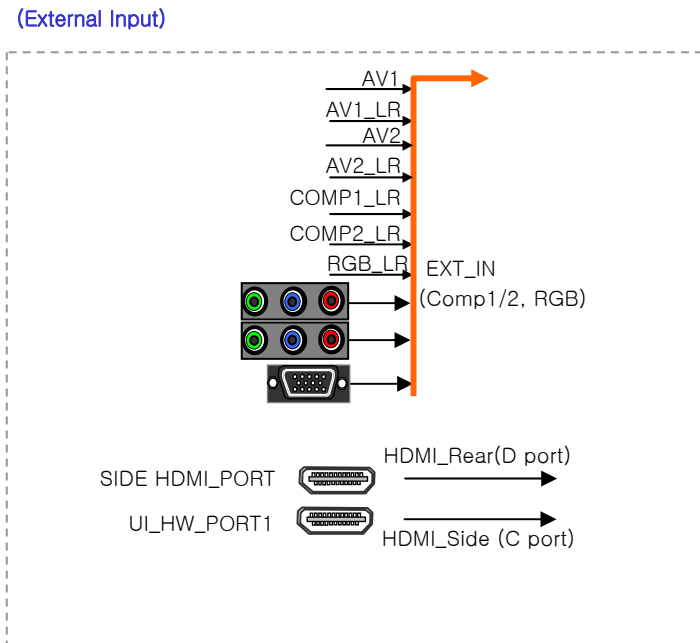
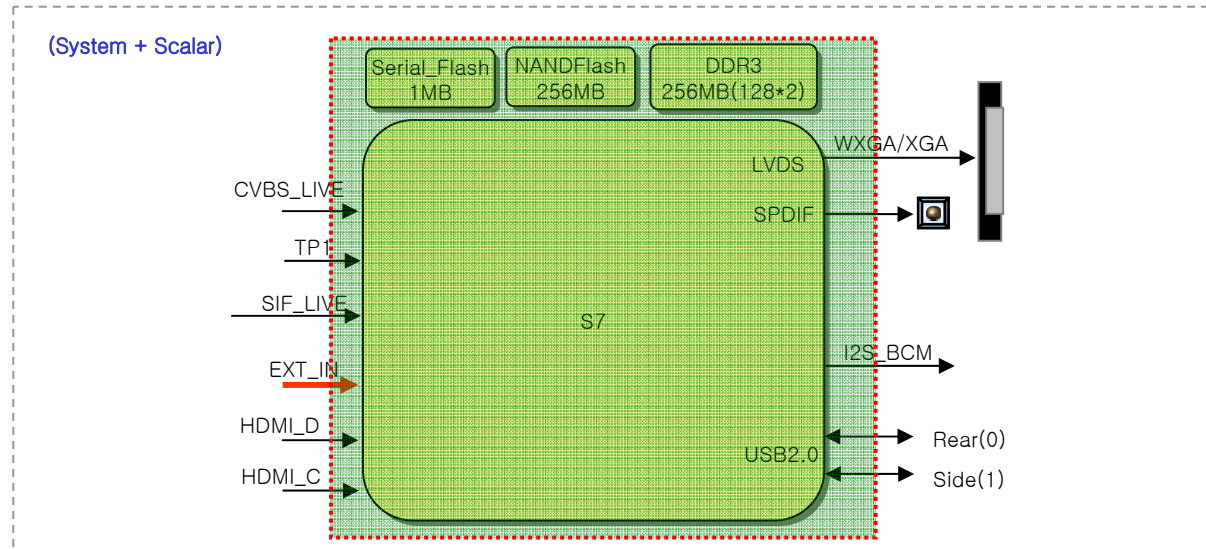
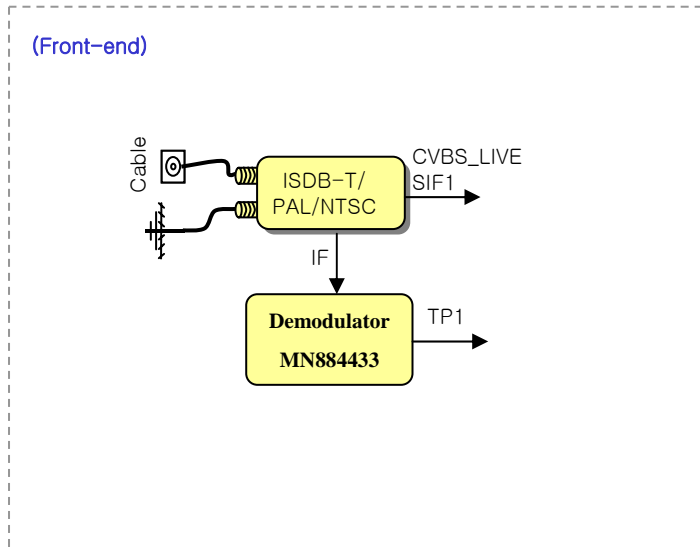

# 1. Power-Up Boot Fail Trouble Shooting

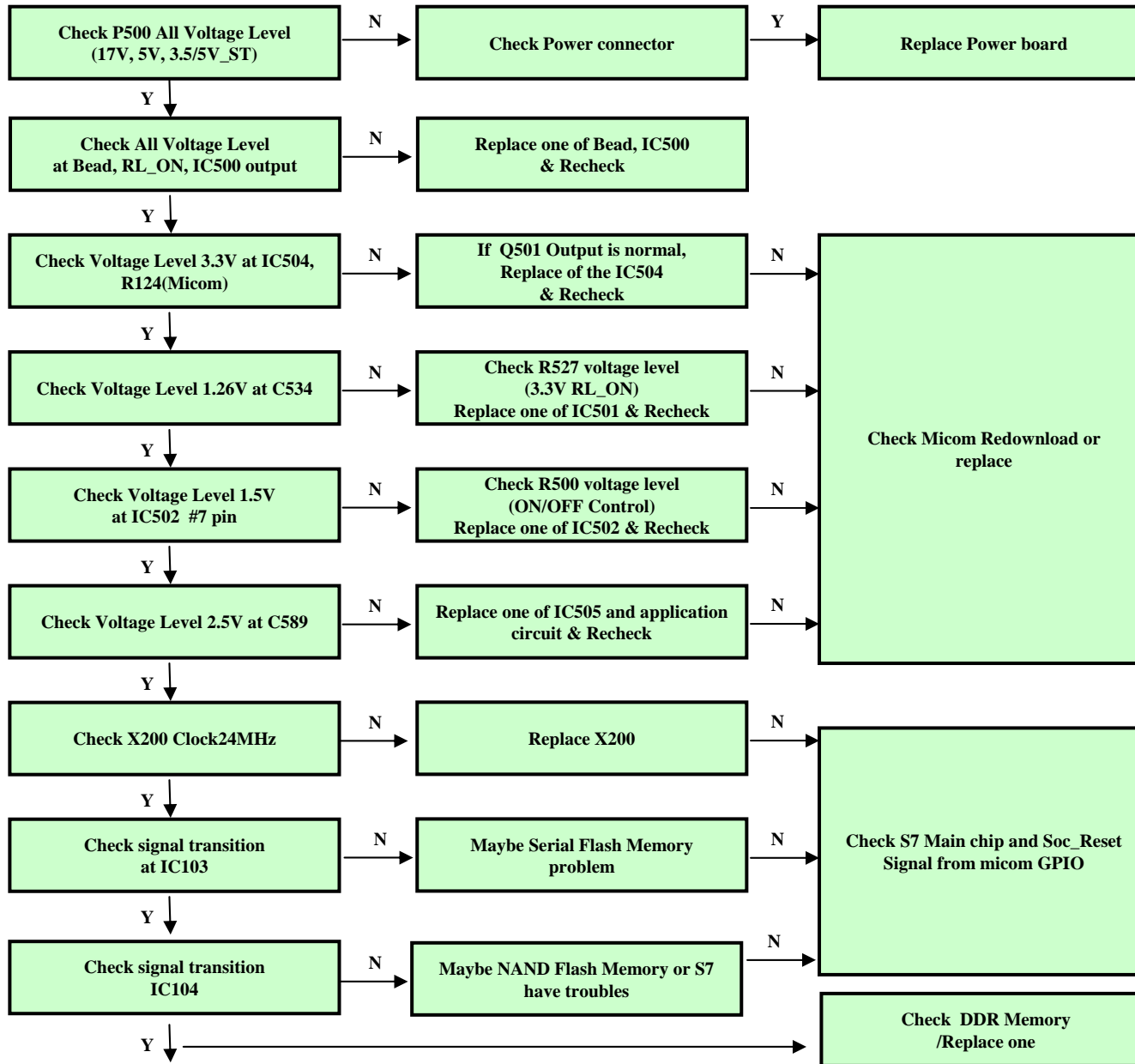

## 2. No OSD Trouble Shooting

(Front-end)

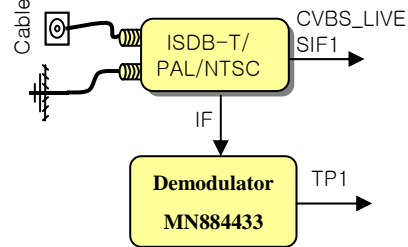

(System + Scalar)

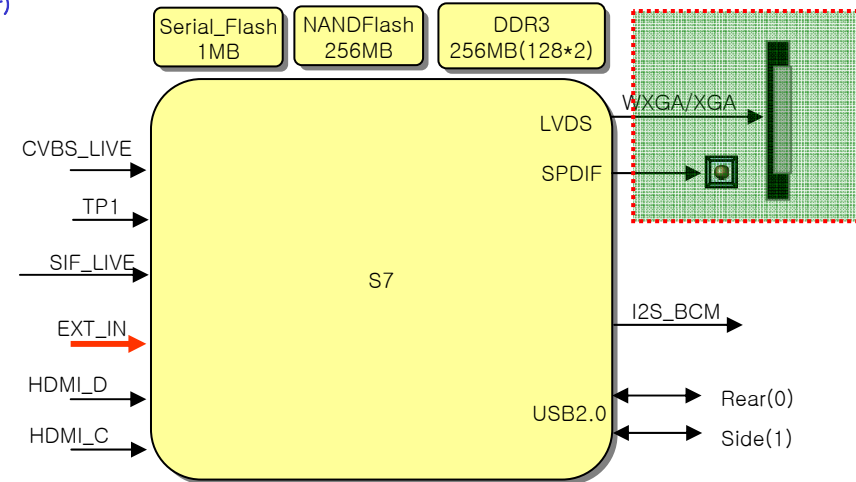

(External Input)

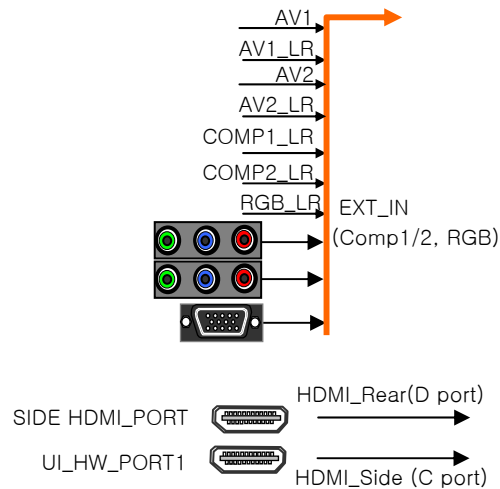

(Audio Out)

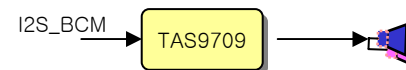

(Micom)

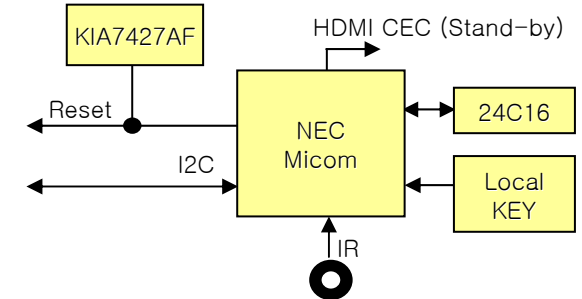

(USB)

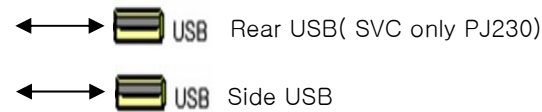

## 2. No OSD Trouble Shooting

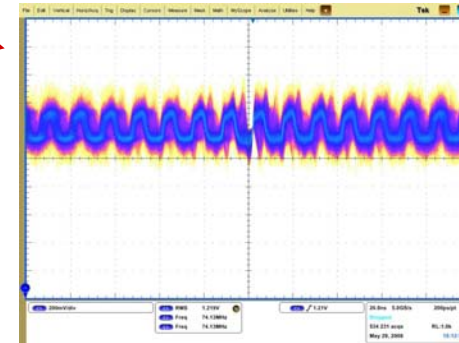
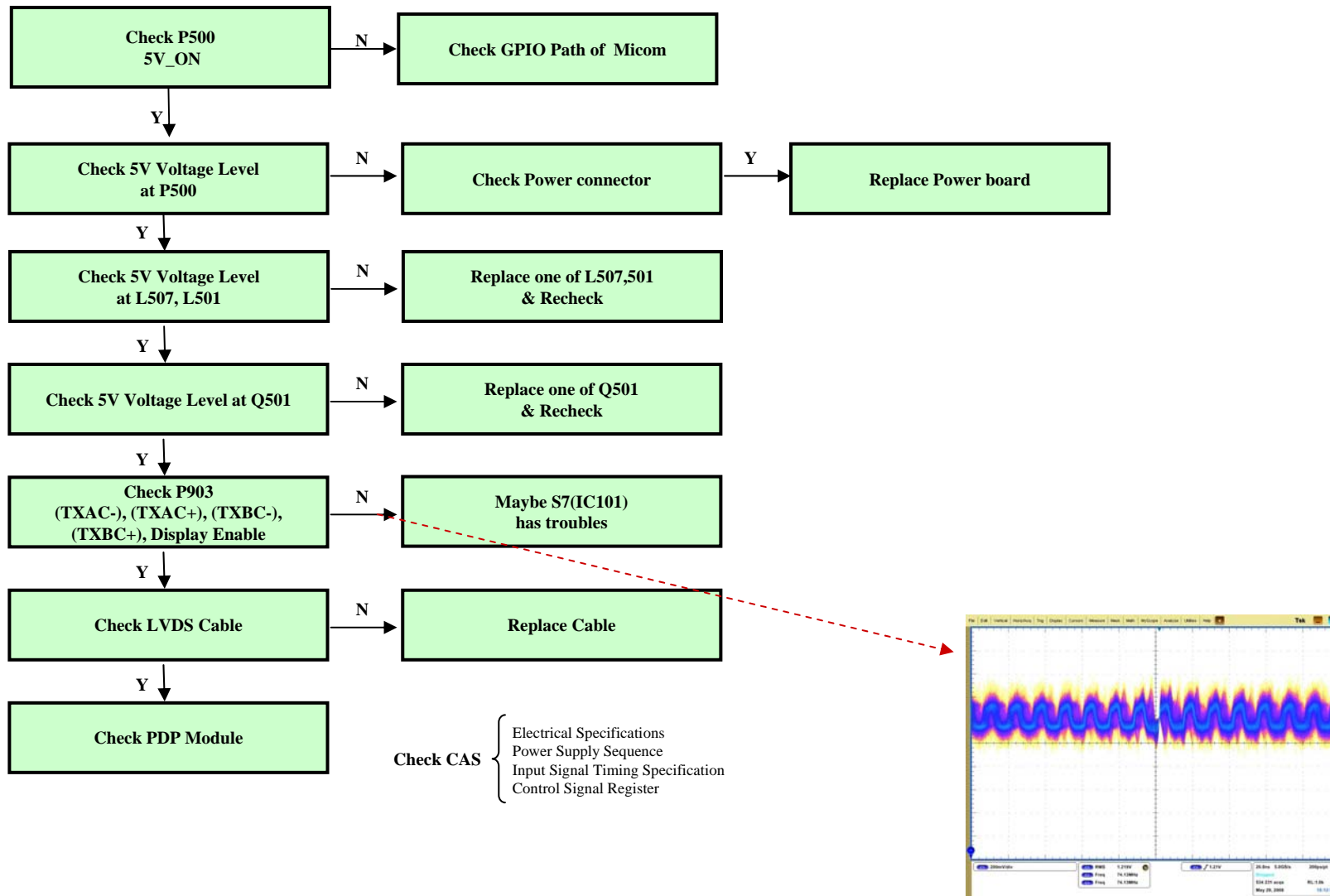

It should satisfy the Pixel Clock on CAS.

# No OSD Trouble Shooting (Module Power Sequence)

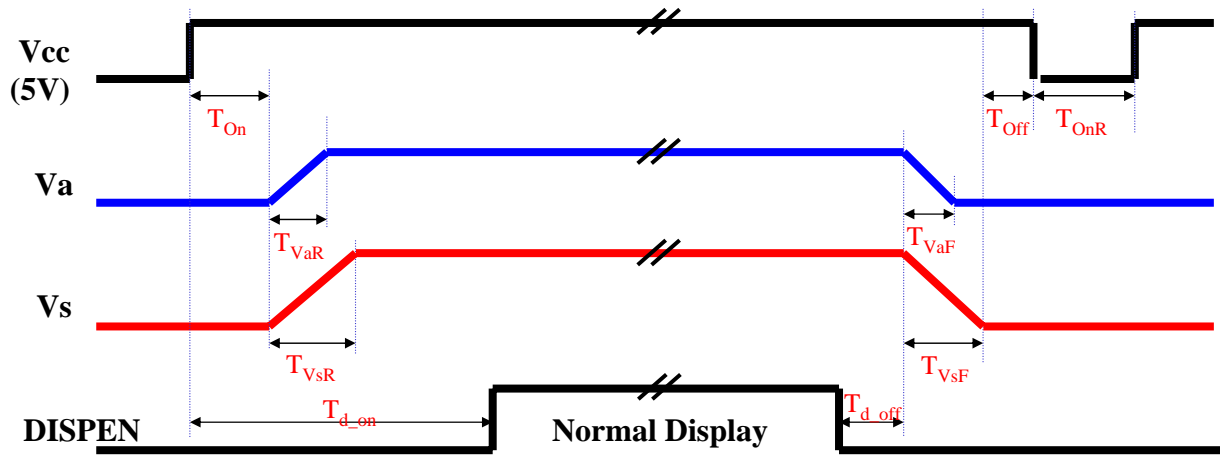

Symbol	Description	Min.	Max.	unit
$T_{On}$	Time interval between 90% of Vcc and 10% of Vs when Power On	750	1250	msec
$T_{Off}$	Time interval between 10% of Vs and 90% of Vcc when Power Off	20	-	msec
$T_{OnR}$	Time interval between 10% of Vcc and 90% of Vcc when Power On	2000	-	msec
$T_{VaR}$	Rising Time of Va (10% to 90%)	10	300	msec
$T_{VaF}$	Falling Time of Va (90% to 10%)	50	500	msec
$T_{VsR}$	Rising Time of Vs (10% to 90%)	100	400	msec
$T_{VsF}$	Falling Time of Vs (90% to 10%)	90	500	msec
$T_{d\_on}$	Time interval between 90% of Vs and DISPEN rising edge when Power On	3100	-	msec
$T_{d\_off}$	Time interval between DISPEN falling edge and 90% of Vs when Power Off	1500	6000	msec
		Recommended 2sec		

# Module Control Trouble Shooting

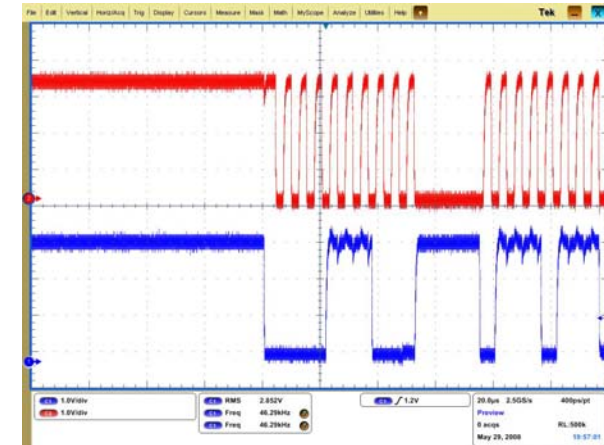
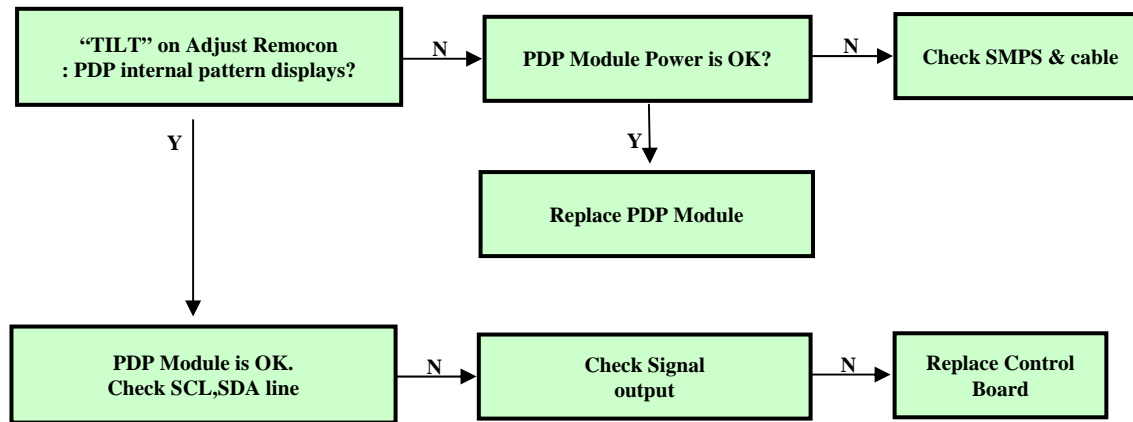

< Sample Signal >

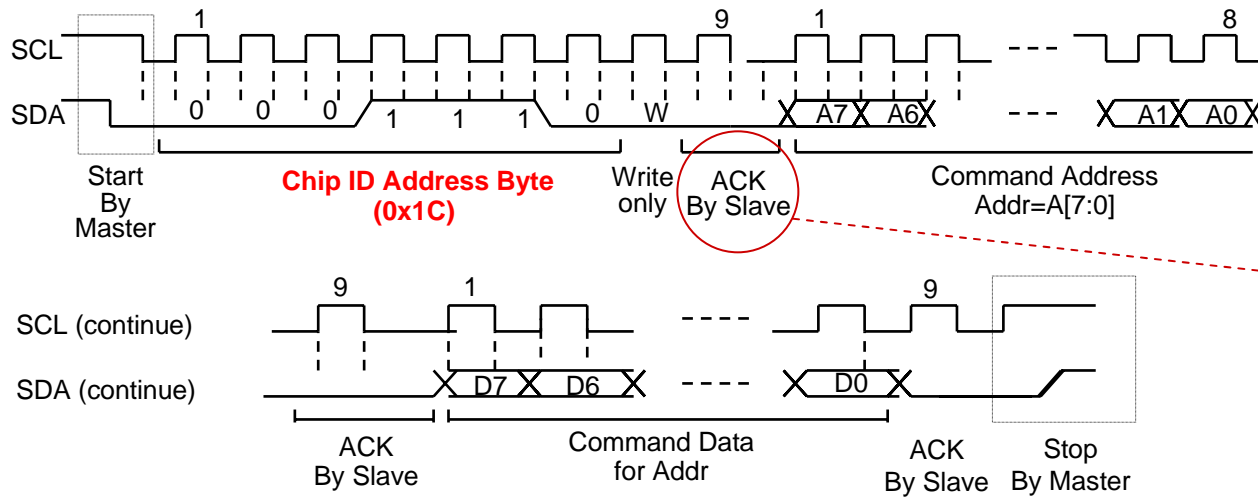

ACK signal Check  
 Low : OK  
 High : Error

Master : Image Board  
 Slave : PDP Module

### 3. Digital TV Video Trouble Shooting

(Front-end)

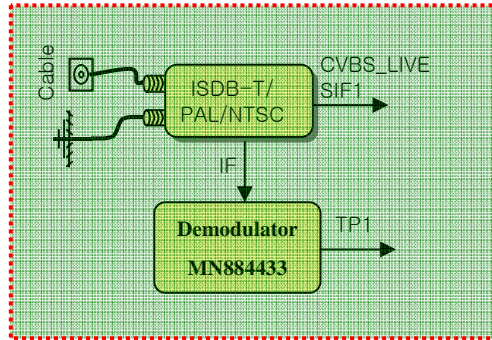

(System + Scalar)

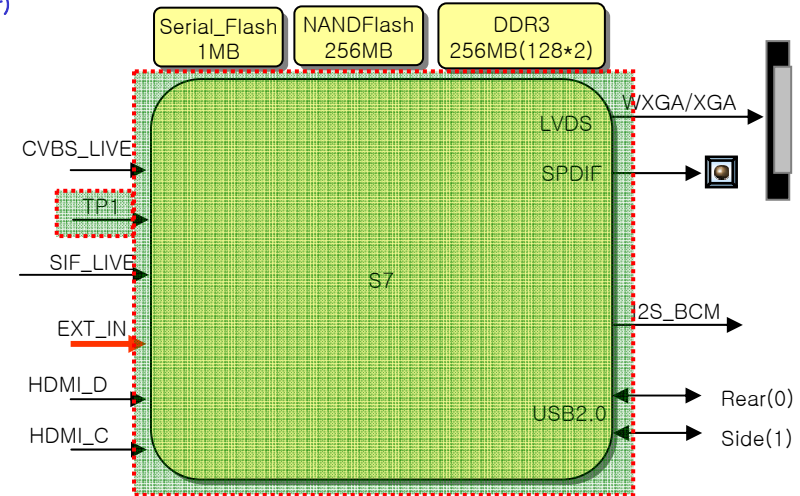

(External Input)

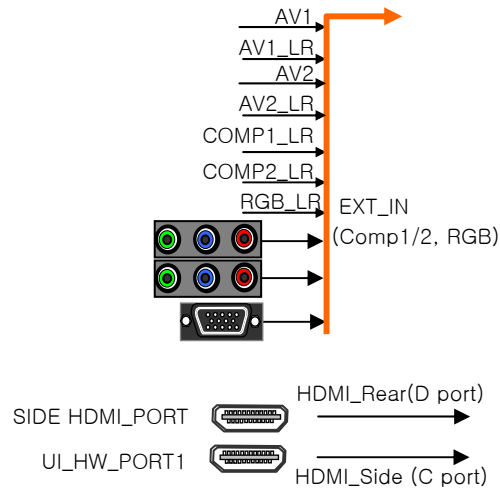

(Audio Out)

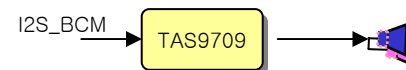

(Micom)

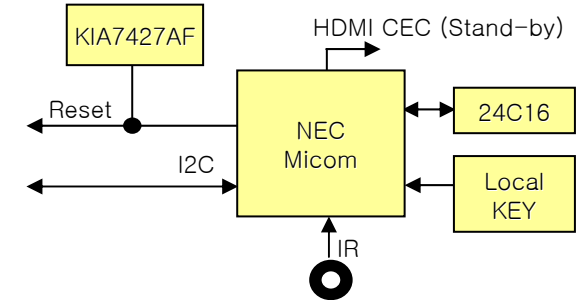

(USB)

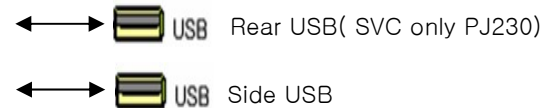

### 3. Digital TV Video Trouble Shooting

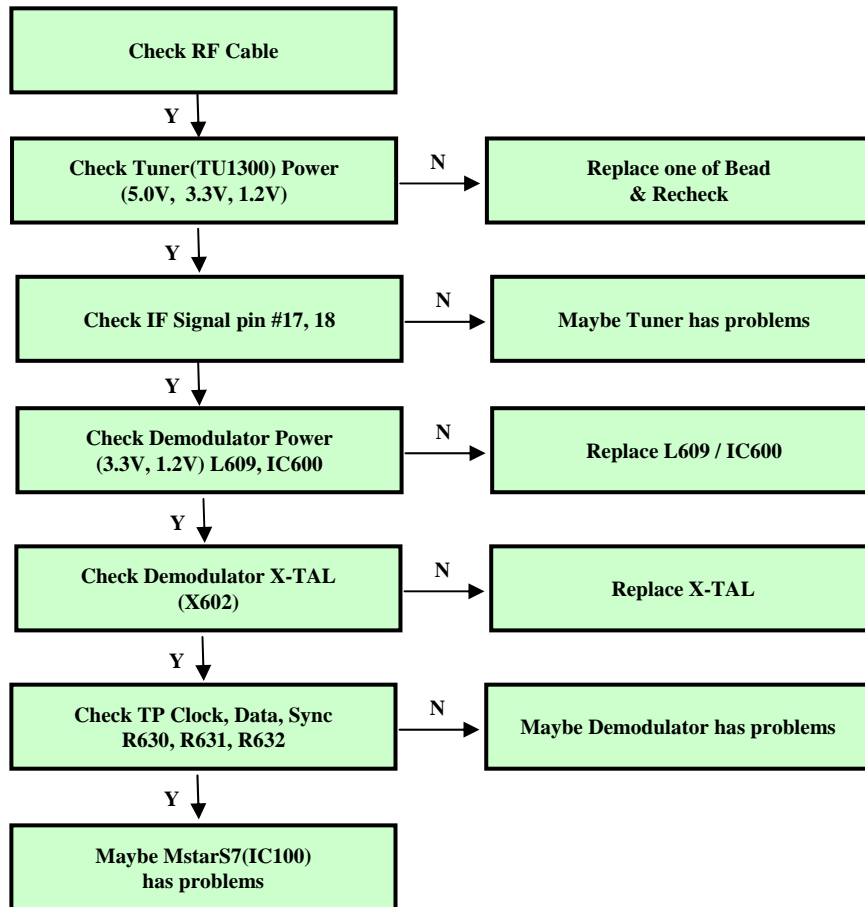



# 4. Analog TV Video Trouble Shooting

(Front-end)

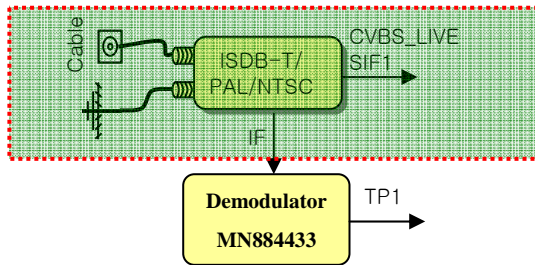

(System + Scalar)

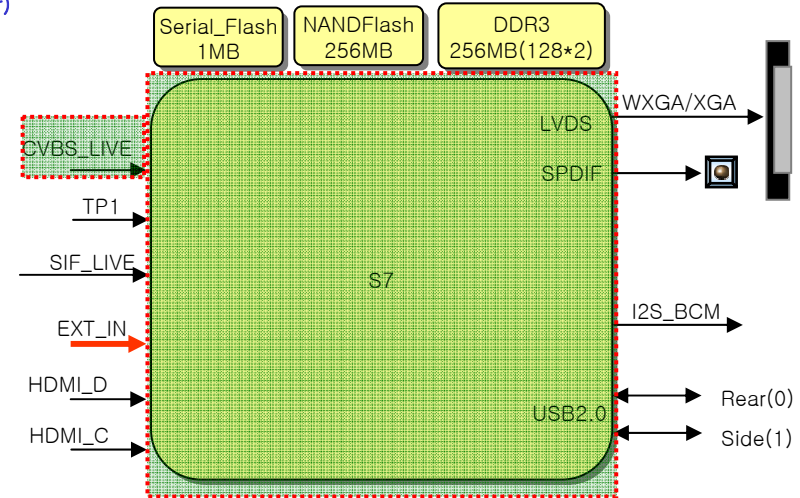

(External Input)

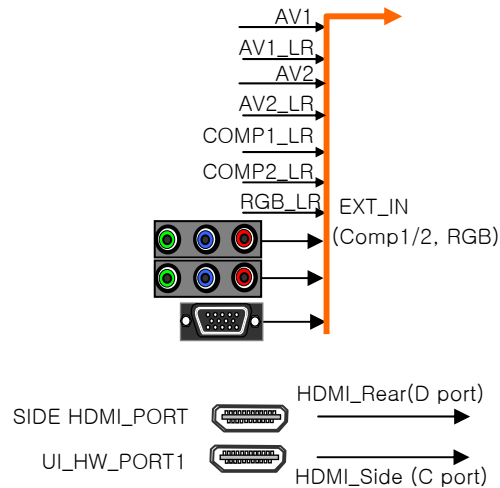

(Audio Out)

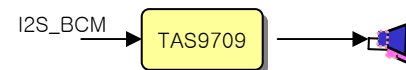

(Micom)

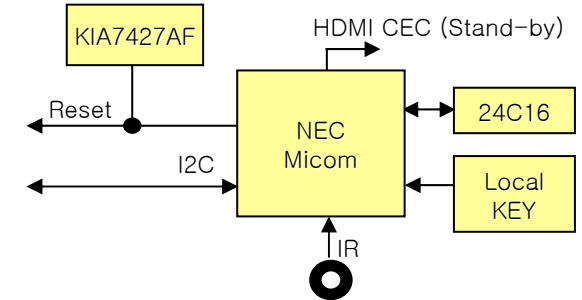

(USB)

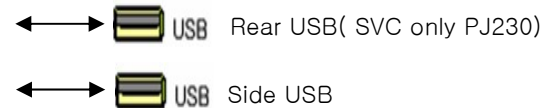

## 4. Analog TV Video Trouble Shooting

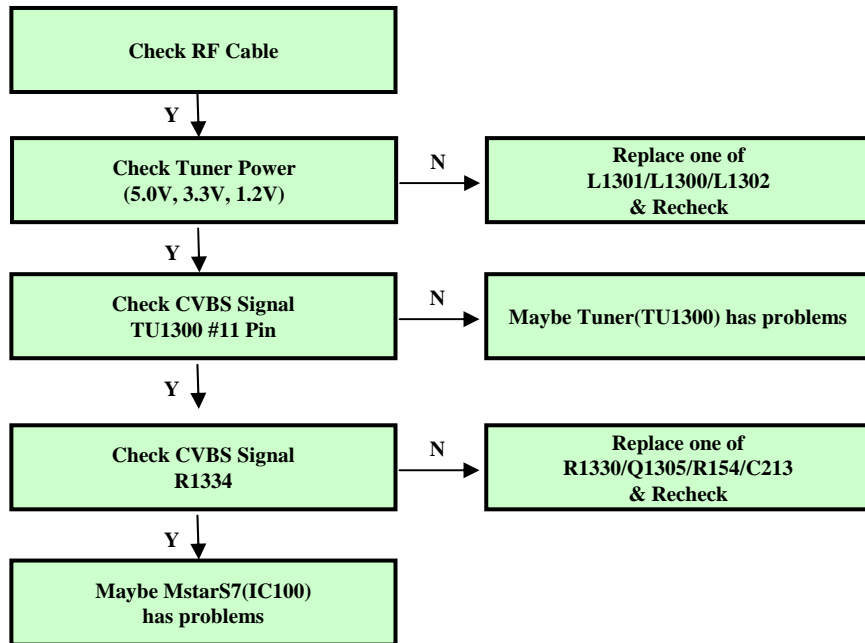

# 5. Component Video Trouble Shooting

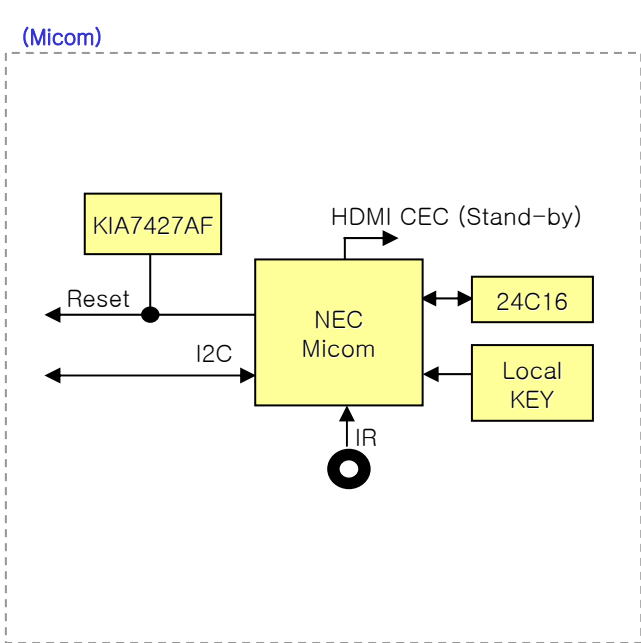
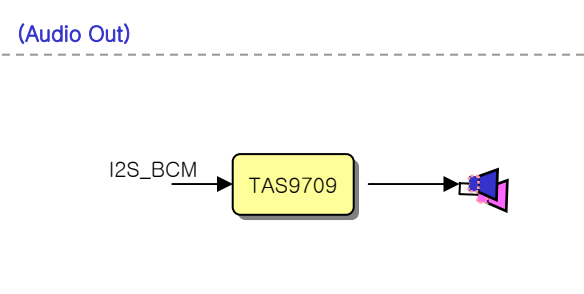
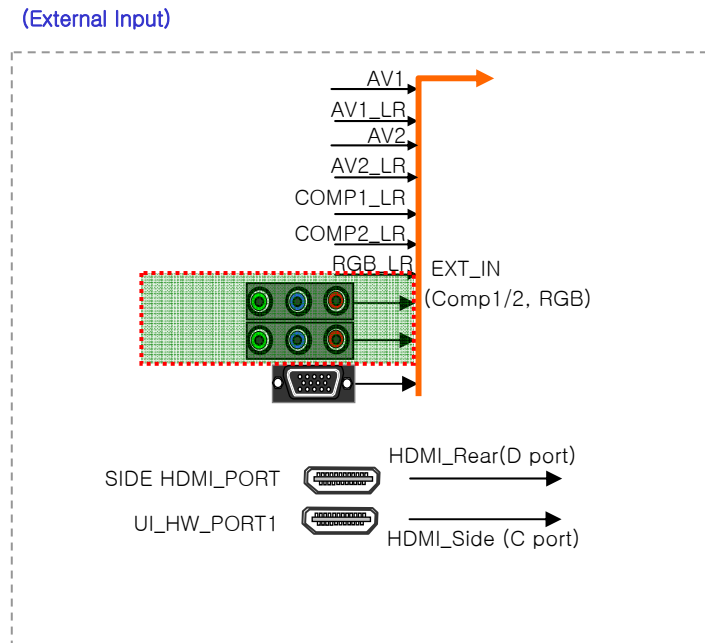
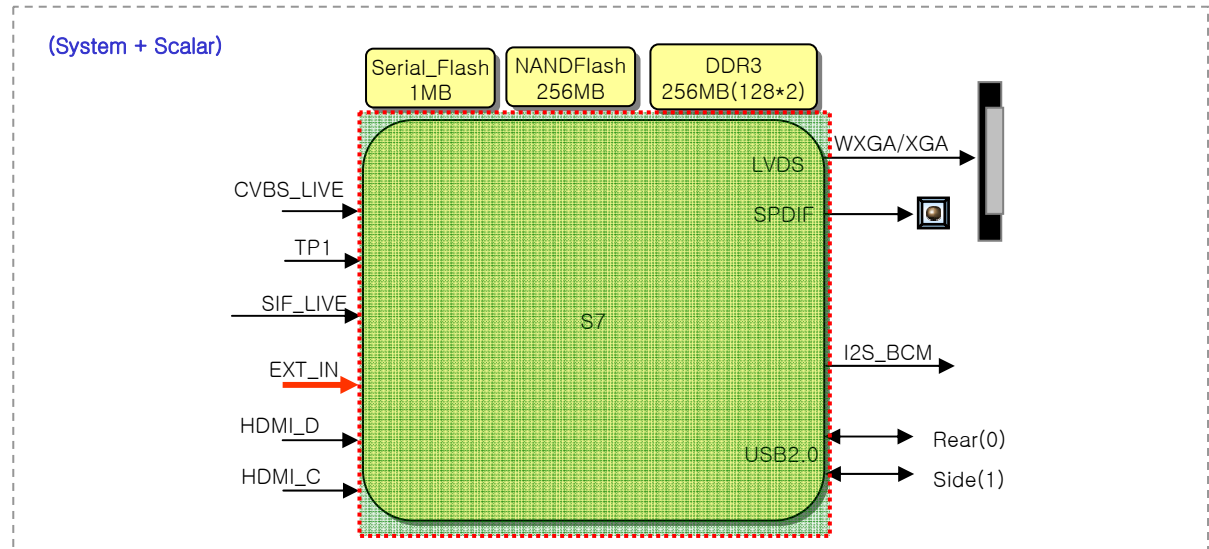
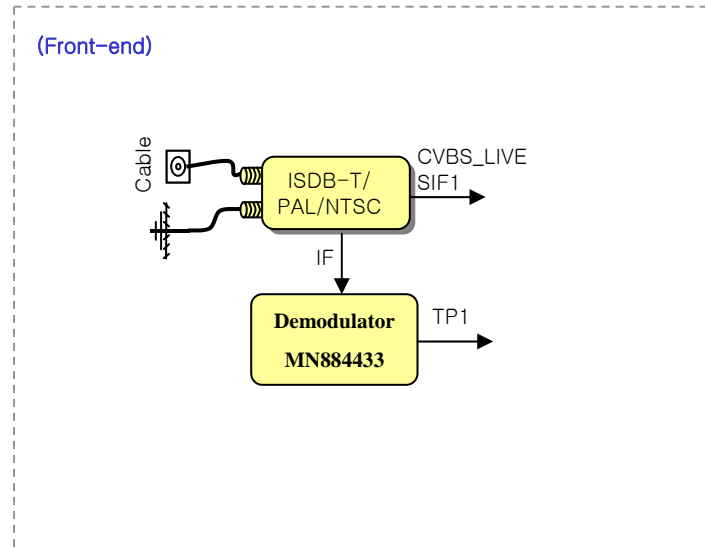

## 5. Component Video Trouble Shooting

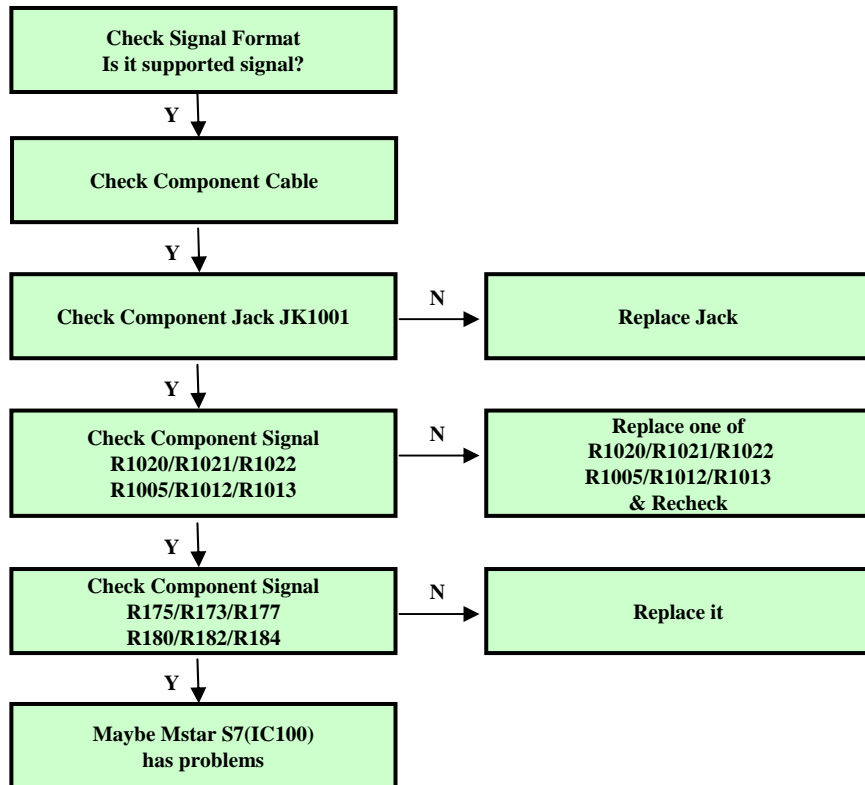

# 6. RGB Video Trouble Shooting

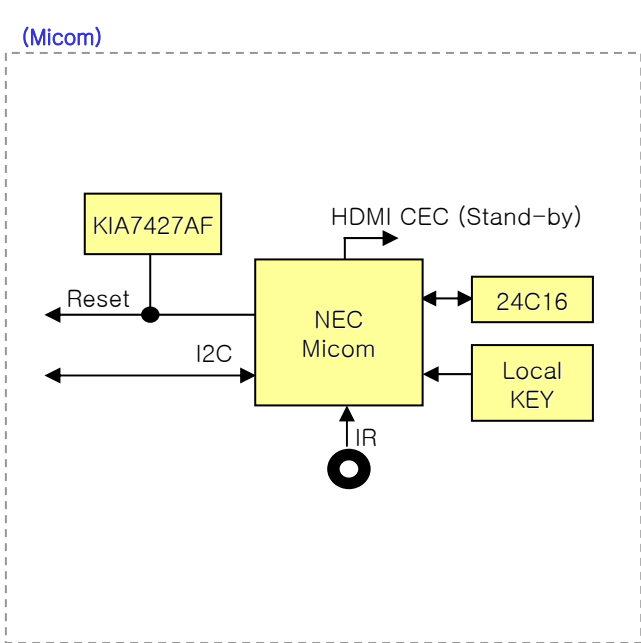
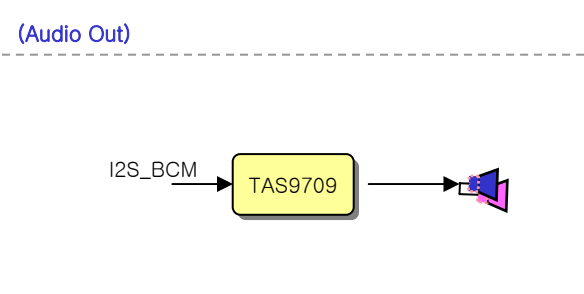
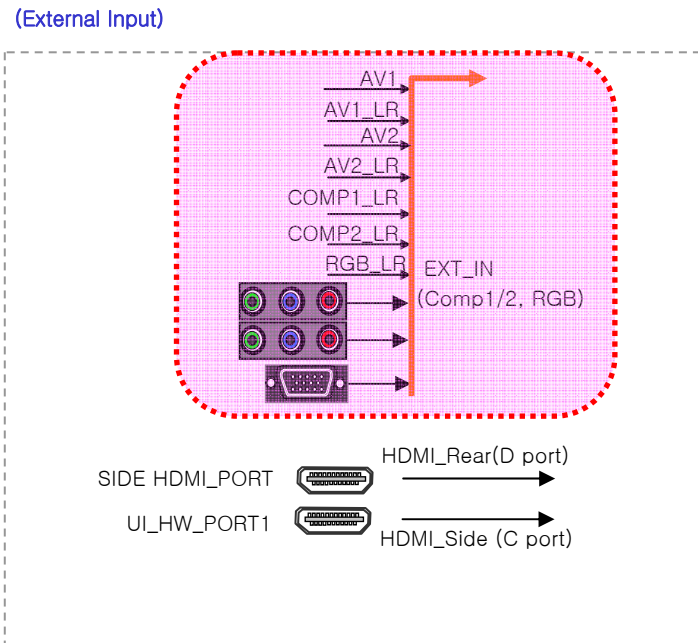
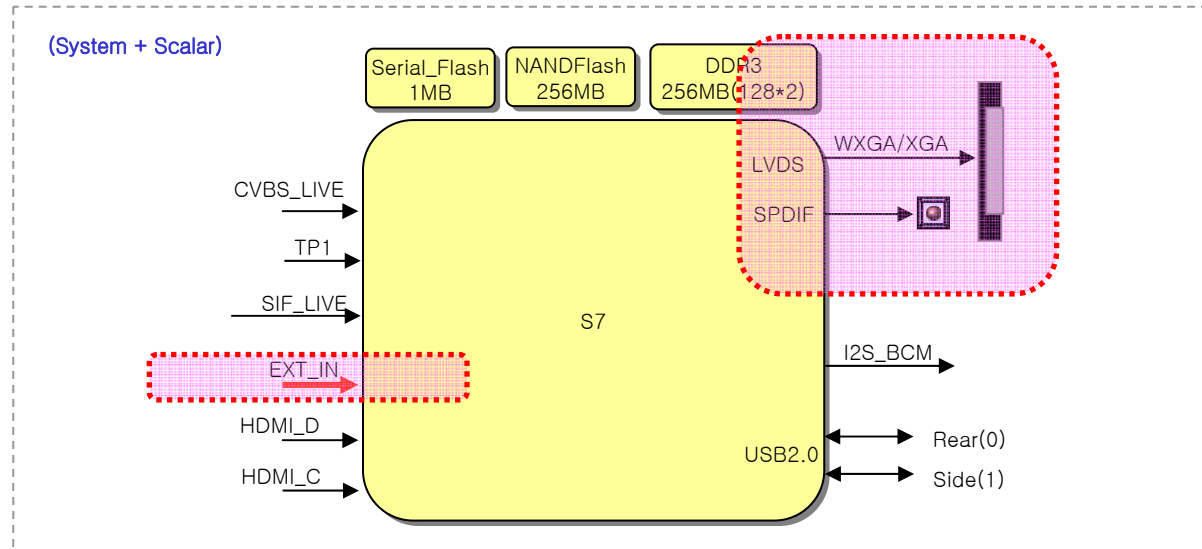
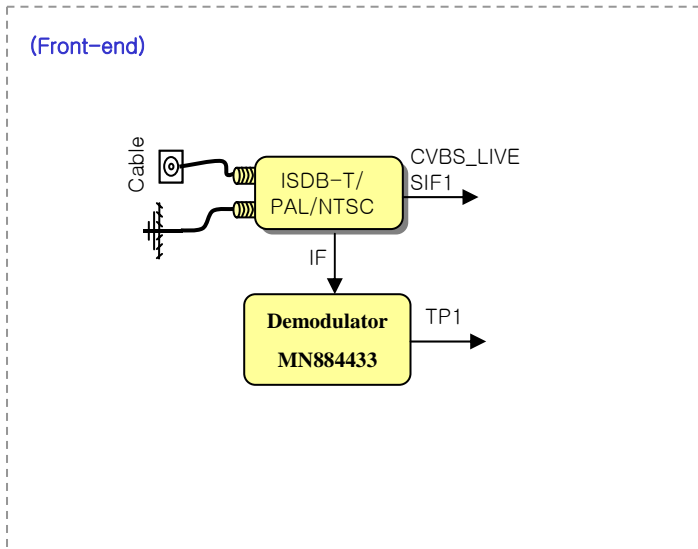

## 6. RGB Video Trouble Shooting

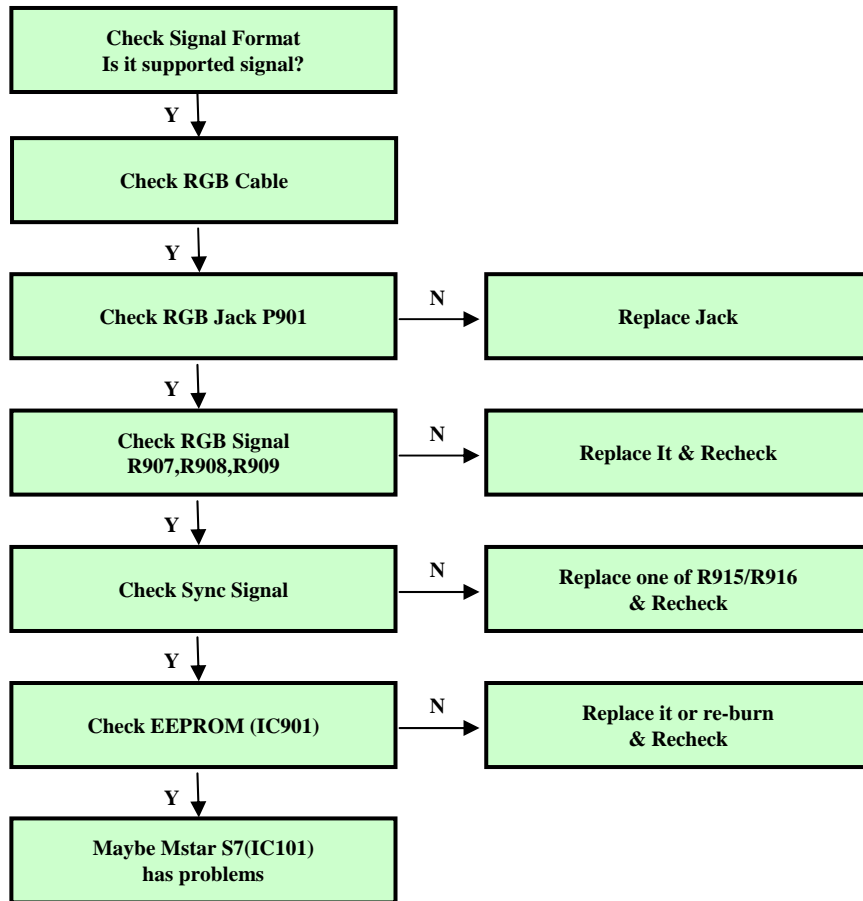

# 7. AV Video Trouble Shooting

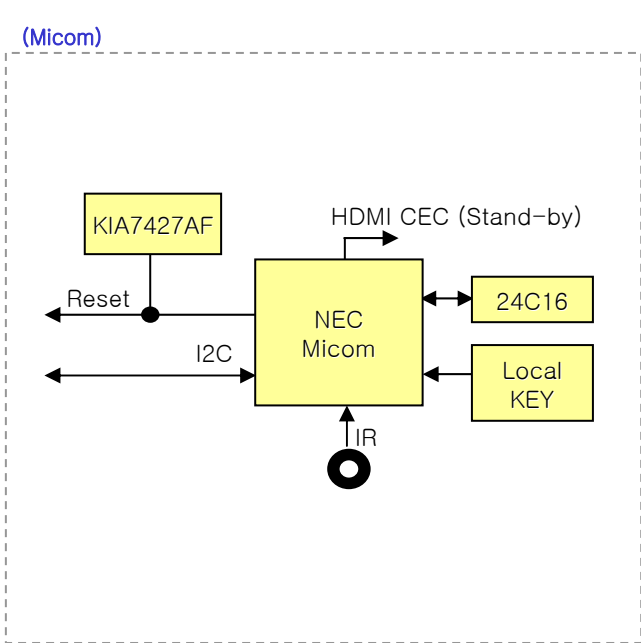
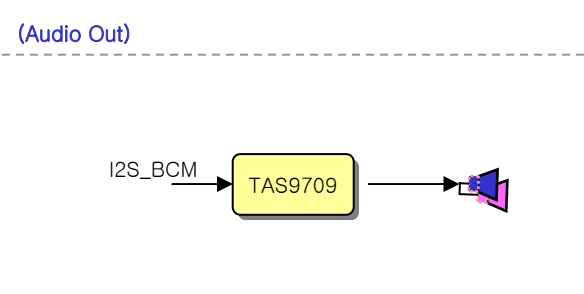
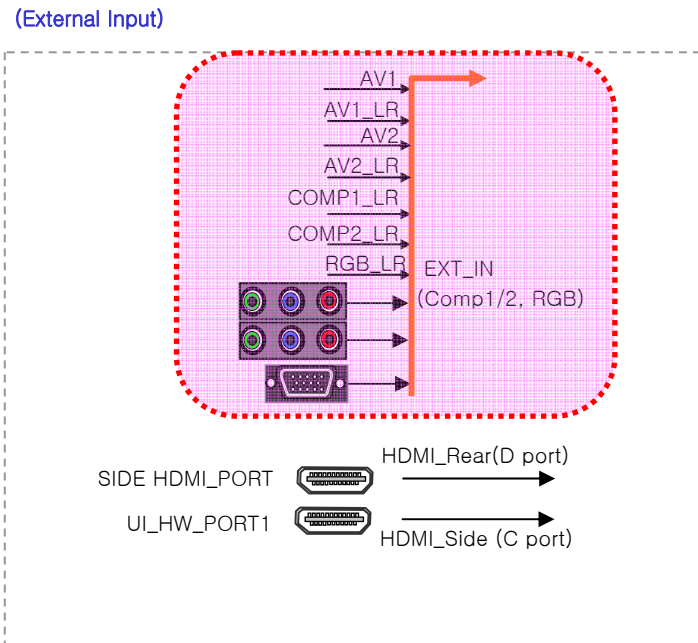
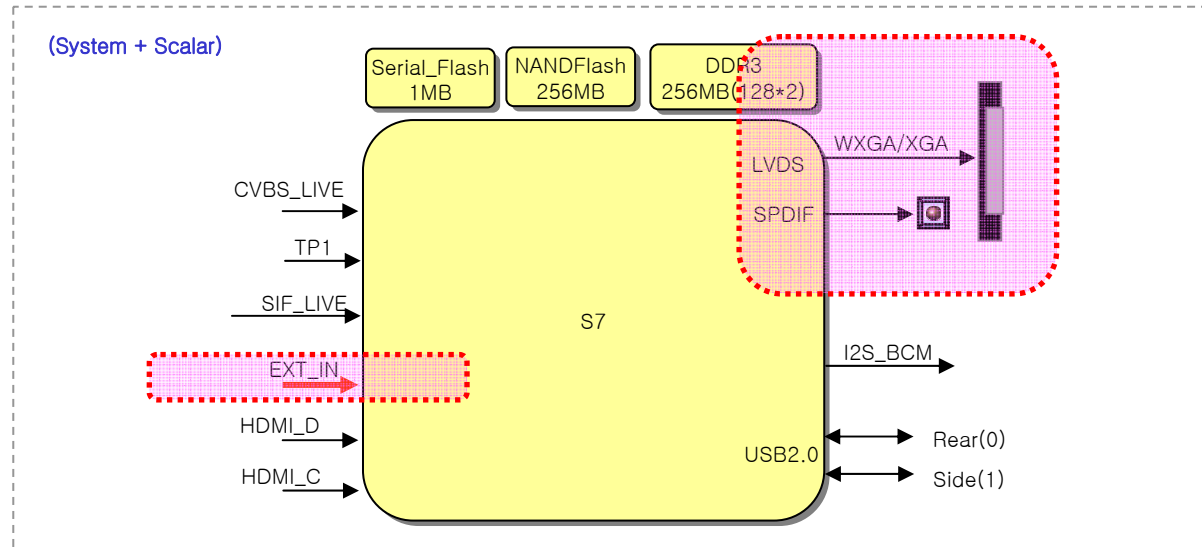
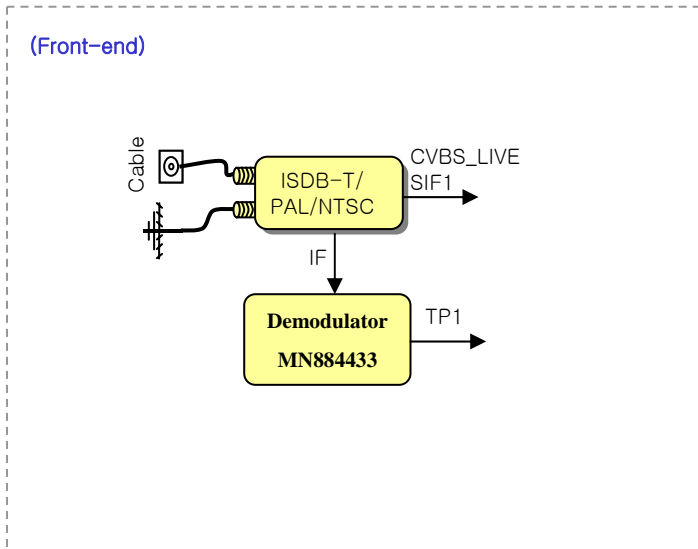

## 7. AV Video Trouble Shooting

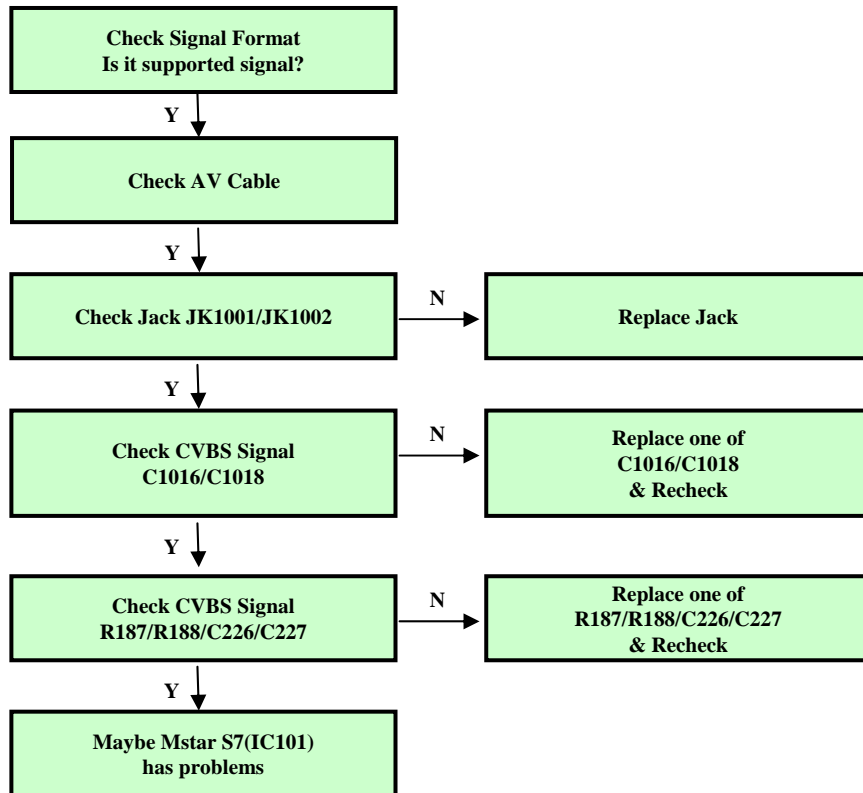



# 8. HDMI Video Trouble Shooting

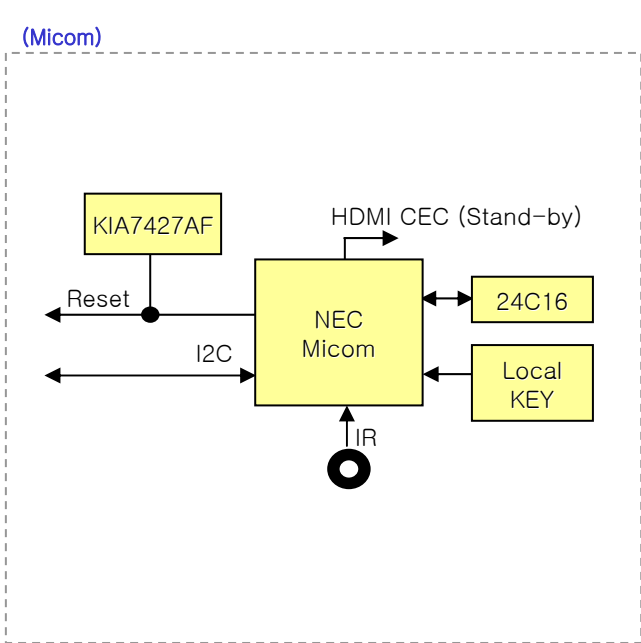
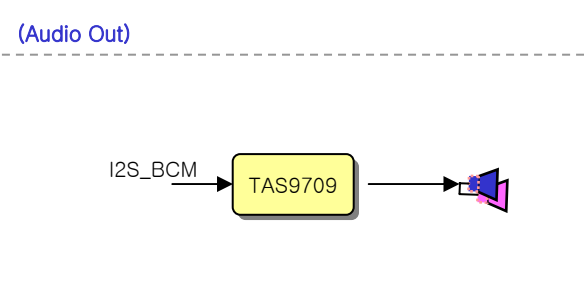
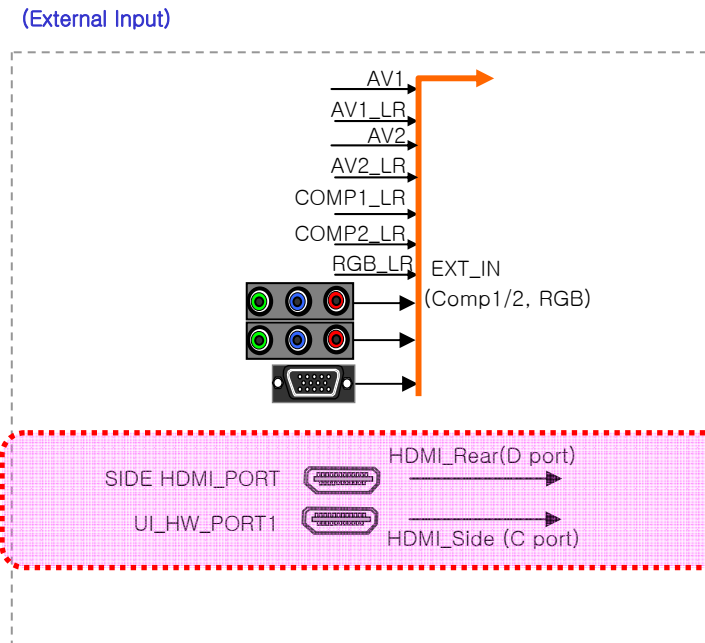
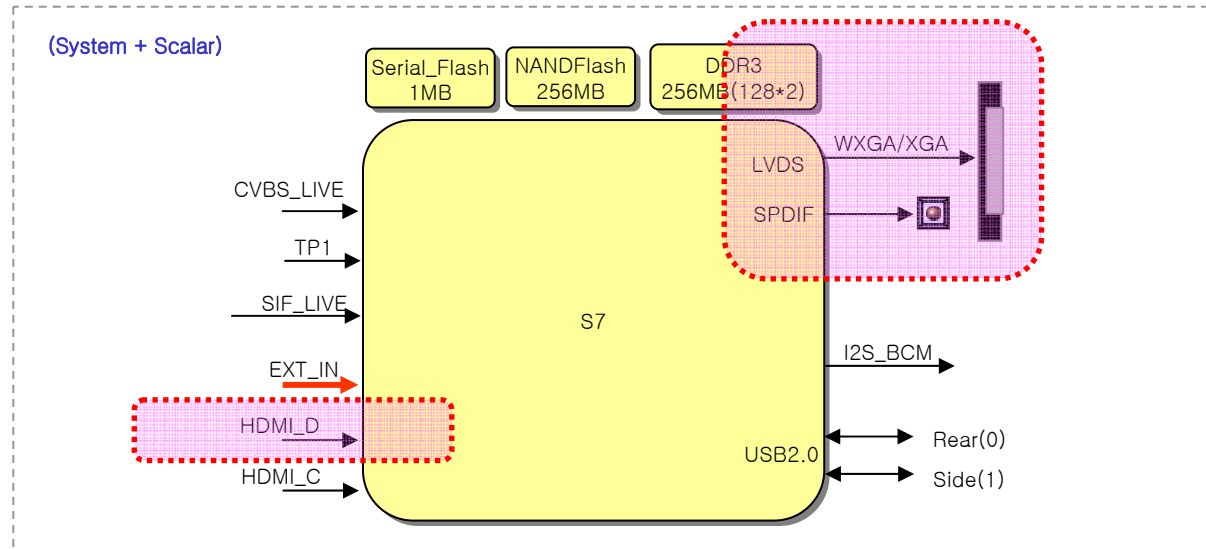
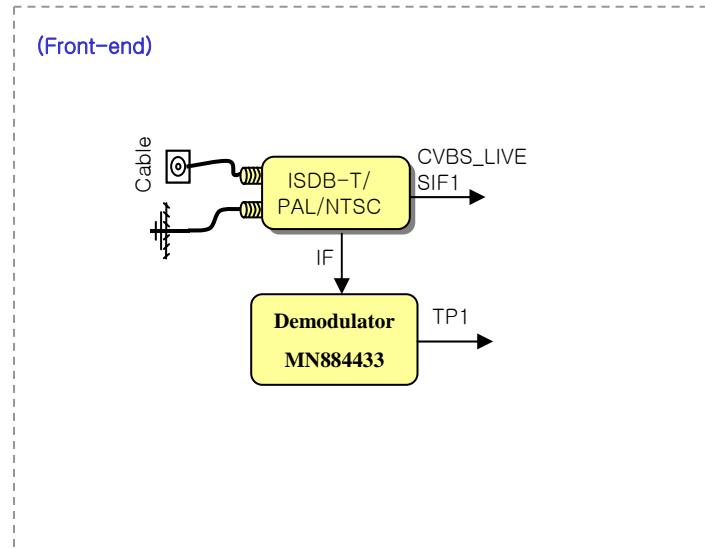

## 8. HDMI Video Trouble Shooting

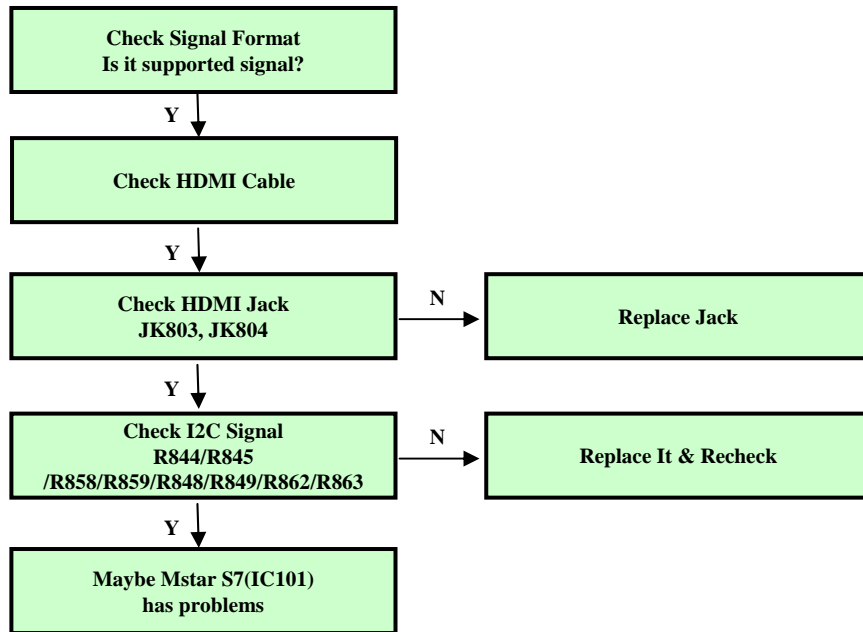

# 9. All Source Audio Trouble Shooting

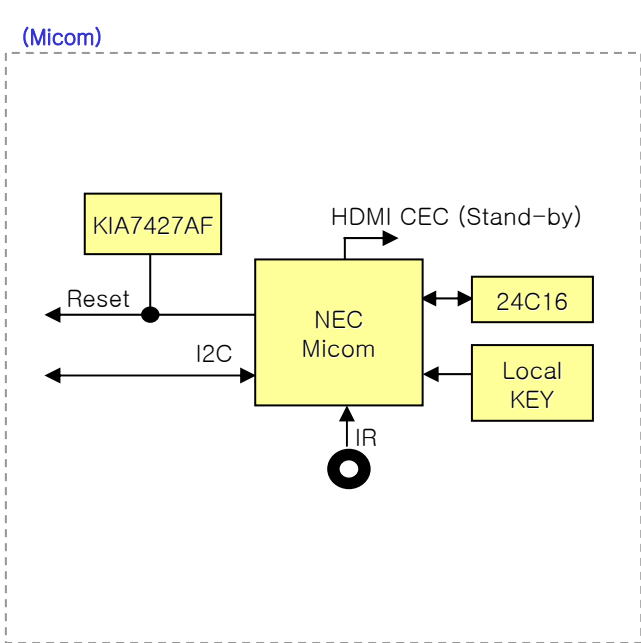
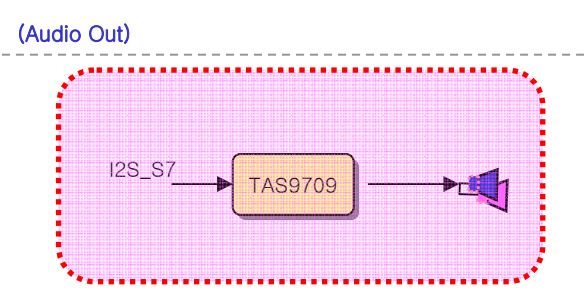
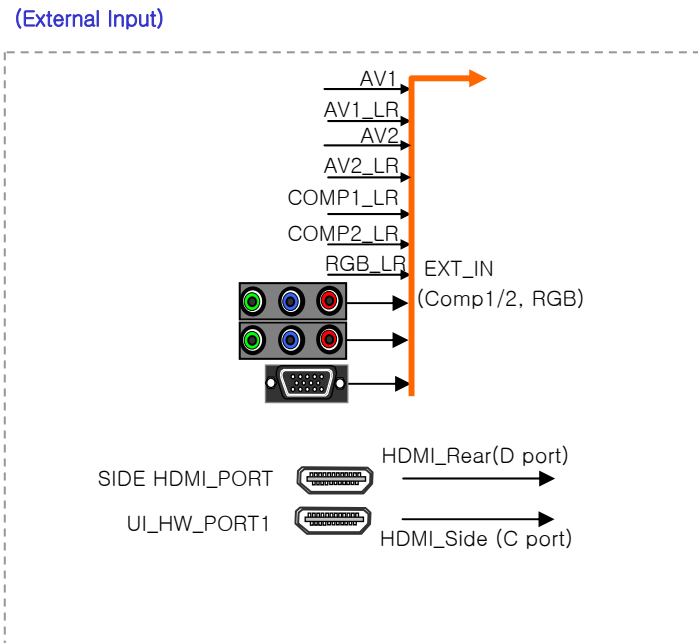
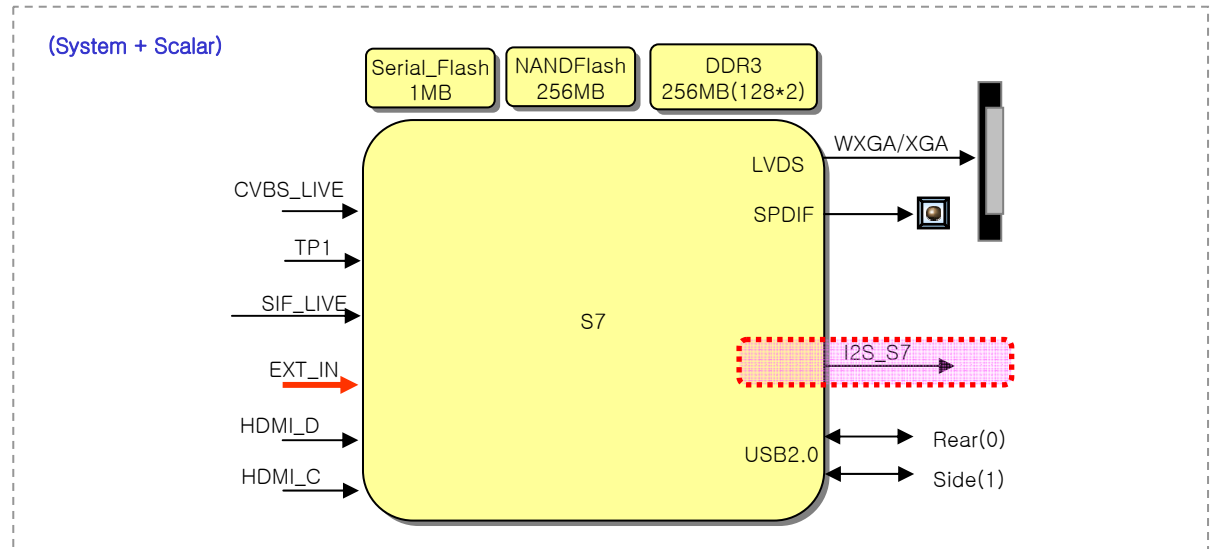
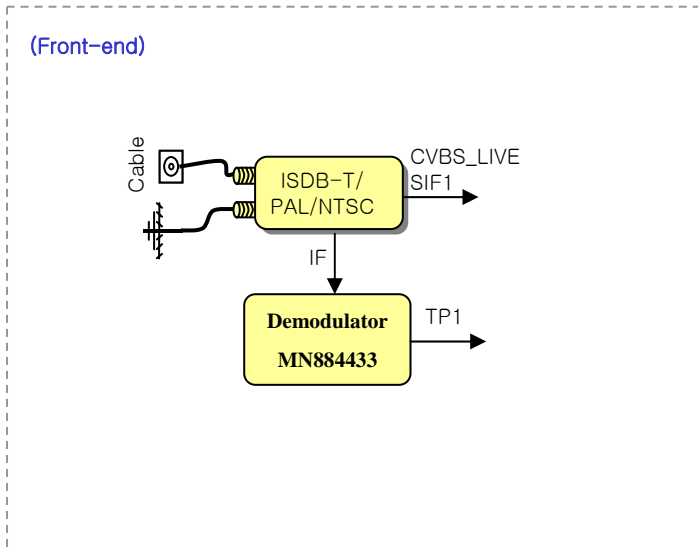

## 9. All Source Audio Trouble Shooting

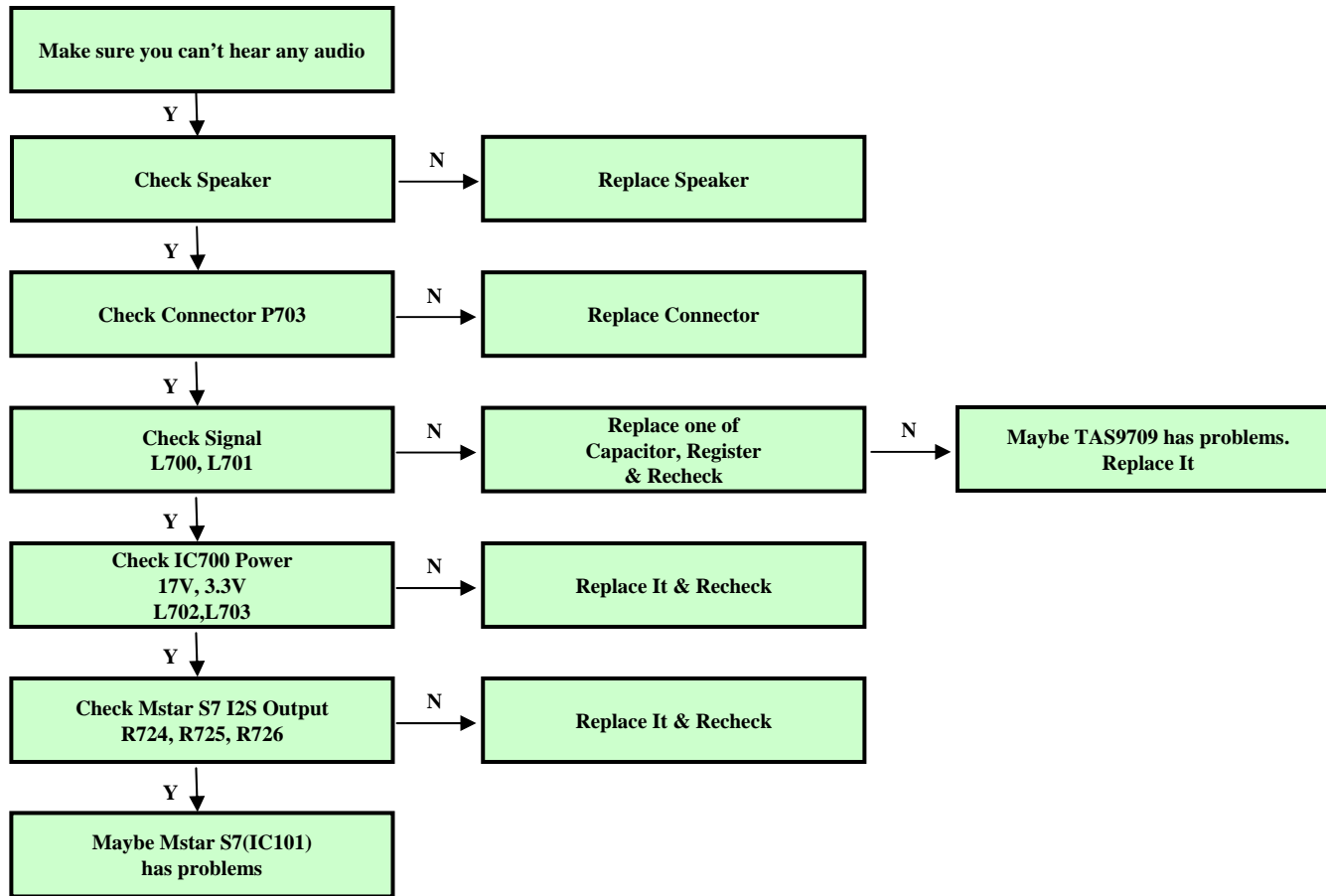

# 10. Digital TV Audio Trouble Shooting

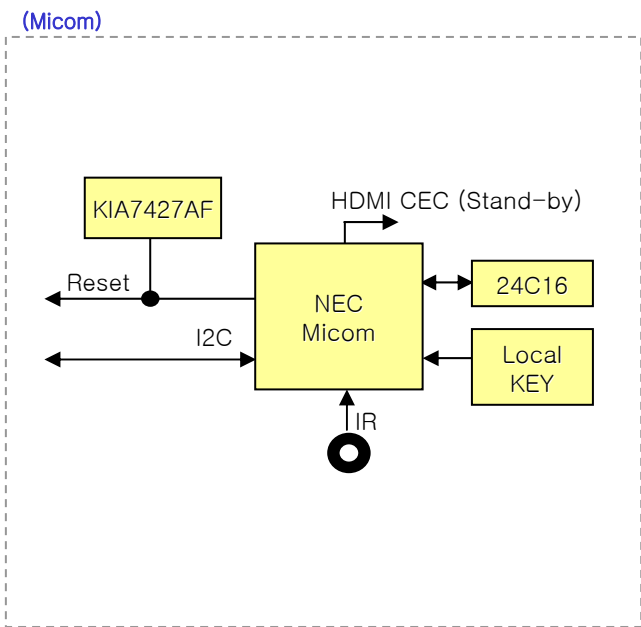
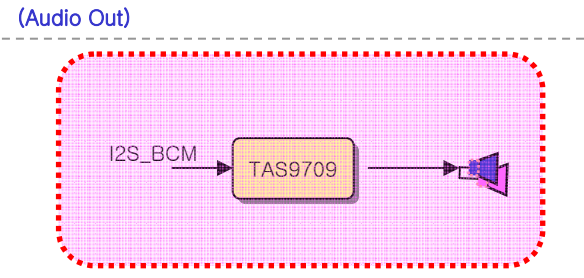
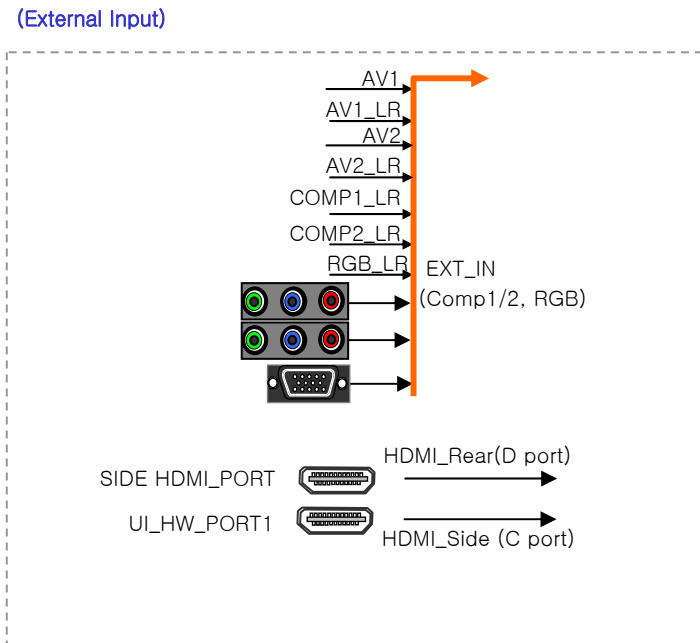
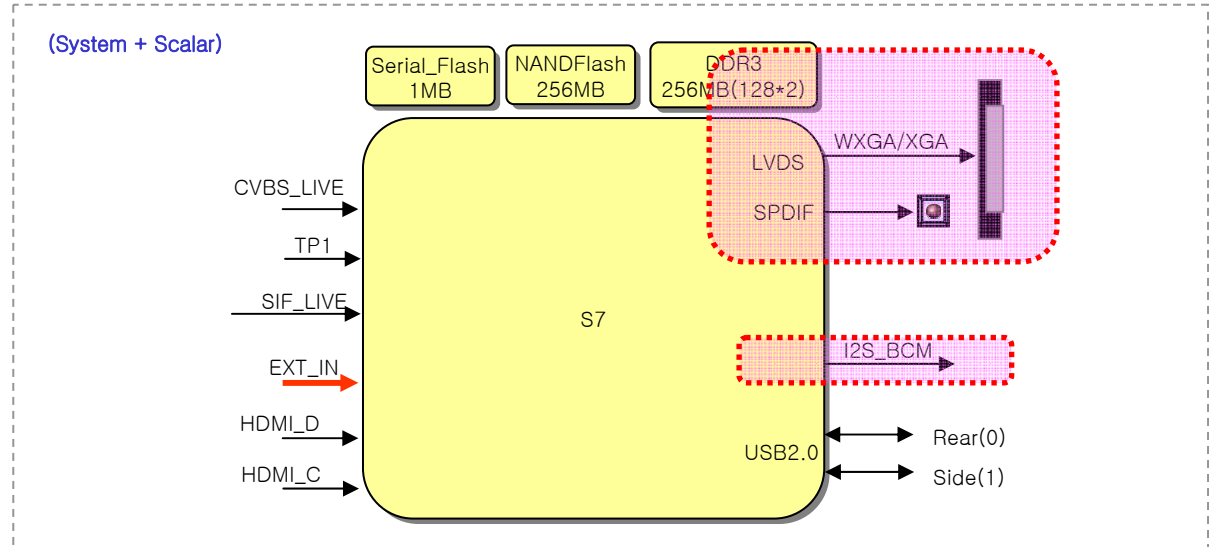
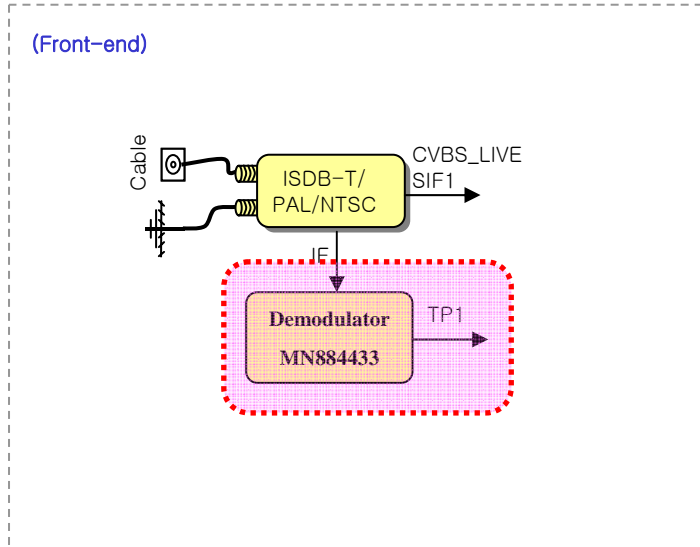

## 10. Digital TV Audio Trouble Shooting

---

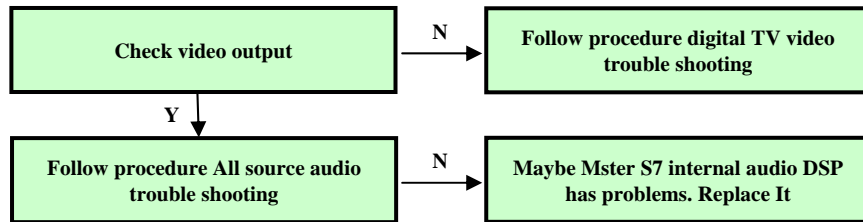

# 11. Analog TV Audio Trouble Shooting

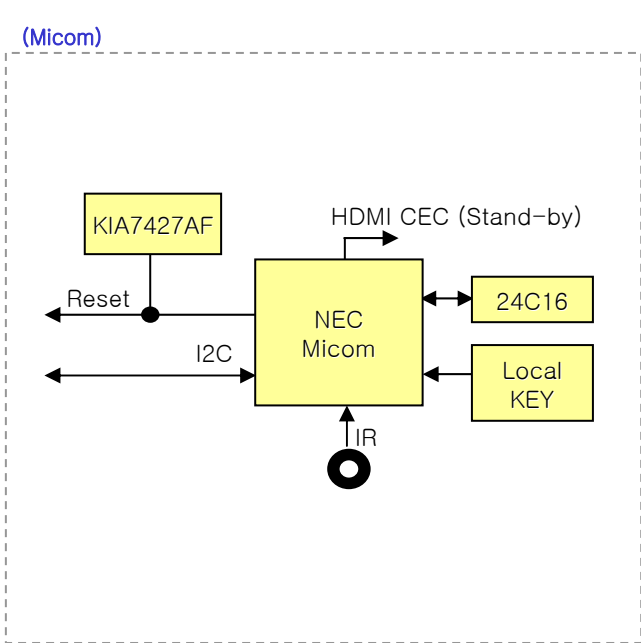
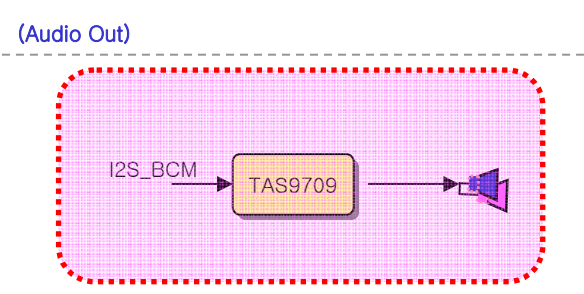
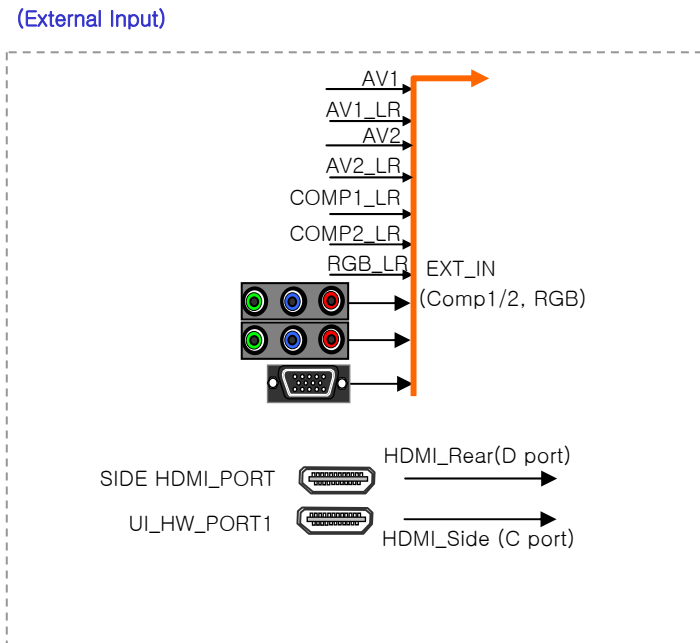
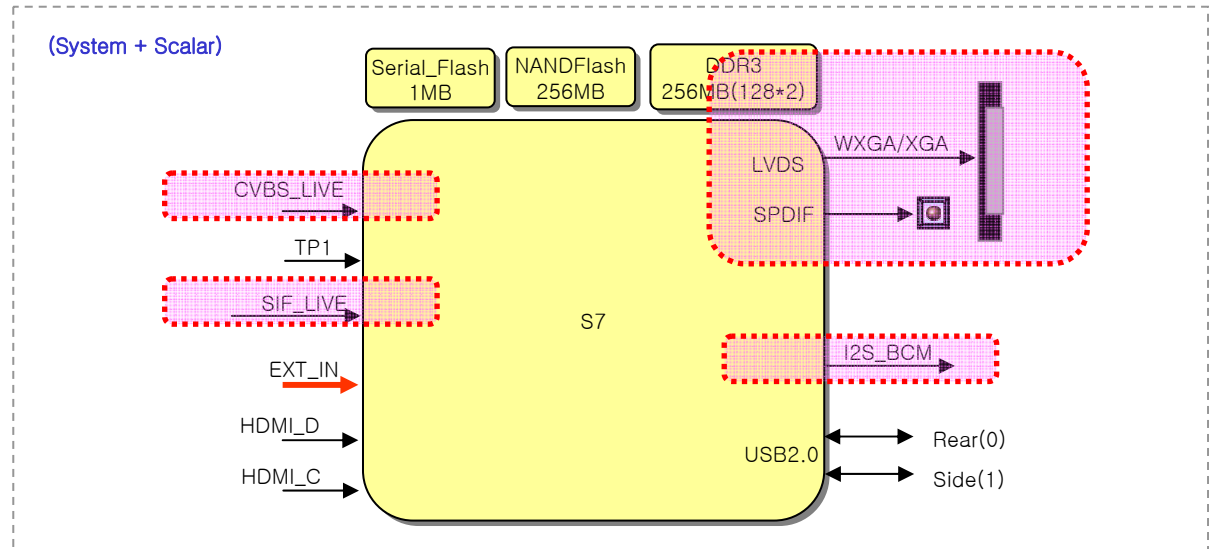
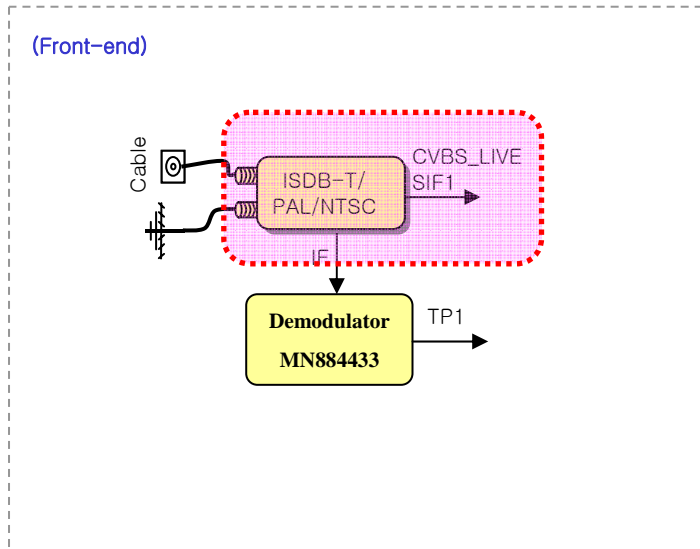

# 11. Analog TV Audio Trouble Shooting

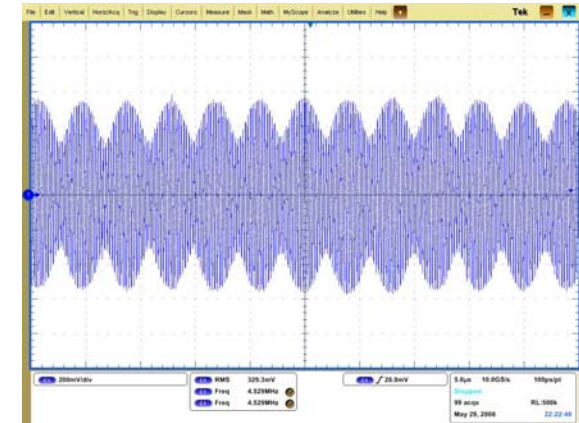
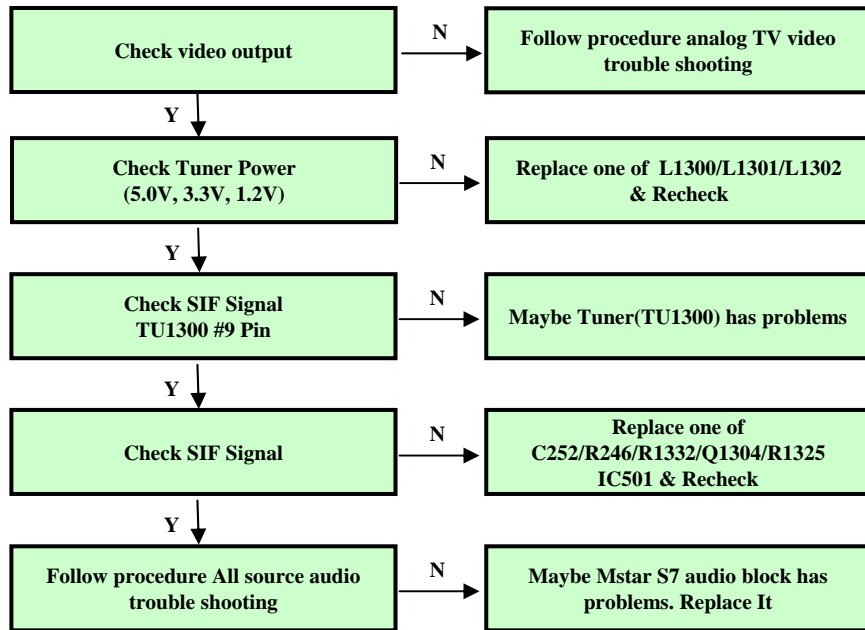

< SIF waveform – sample >  
– Depend on the input signal.



# 12. Component / RGB / AV Audio Trouble Shooting

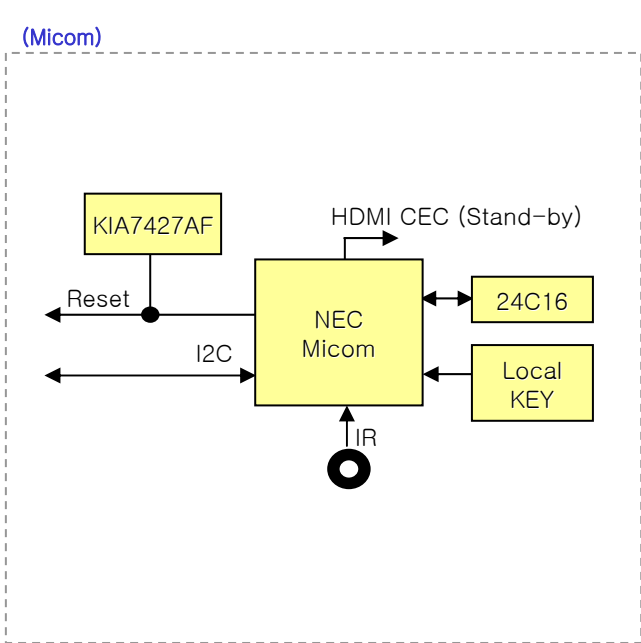
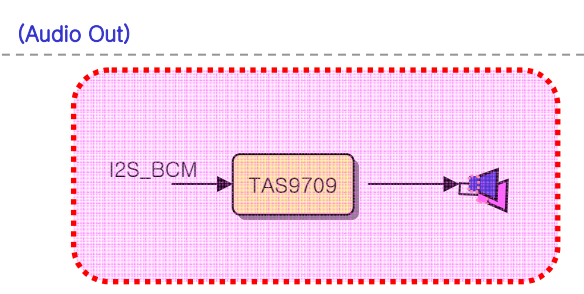
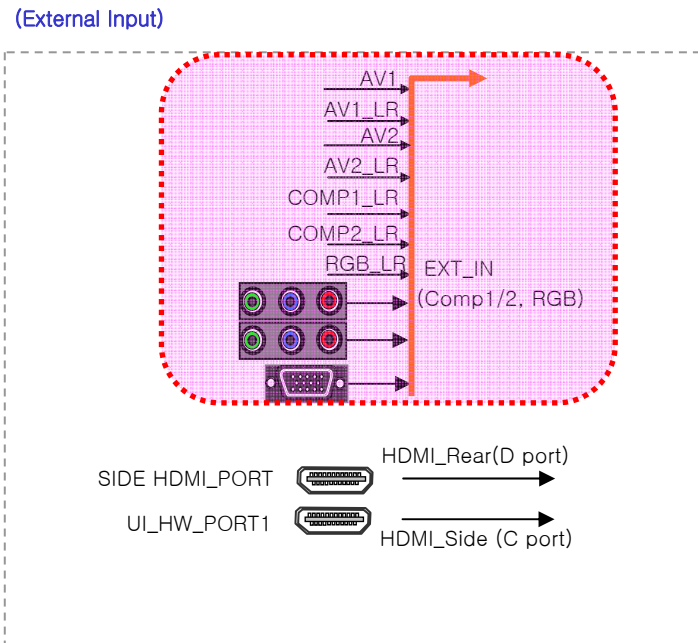
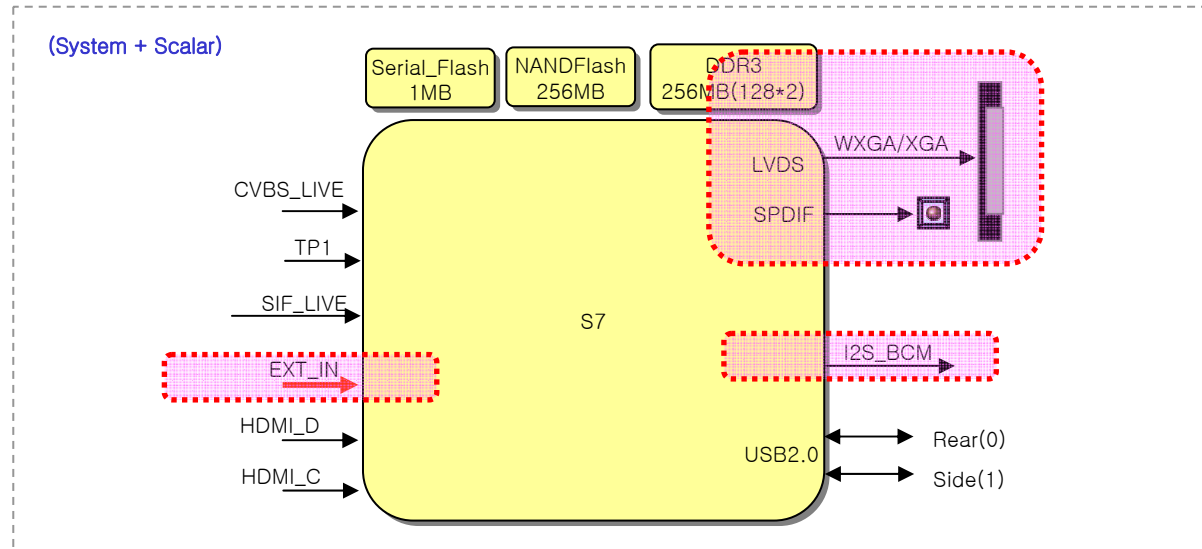
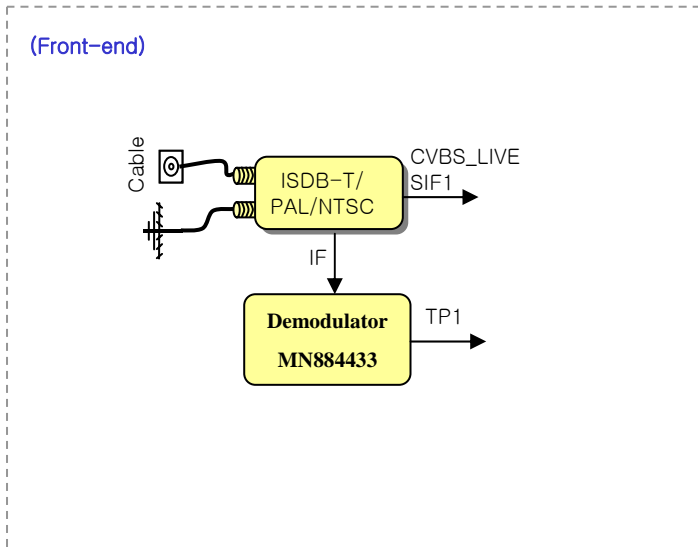

## 12. Component / RGB / AV Audio Trouble Shooting

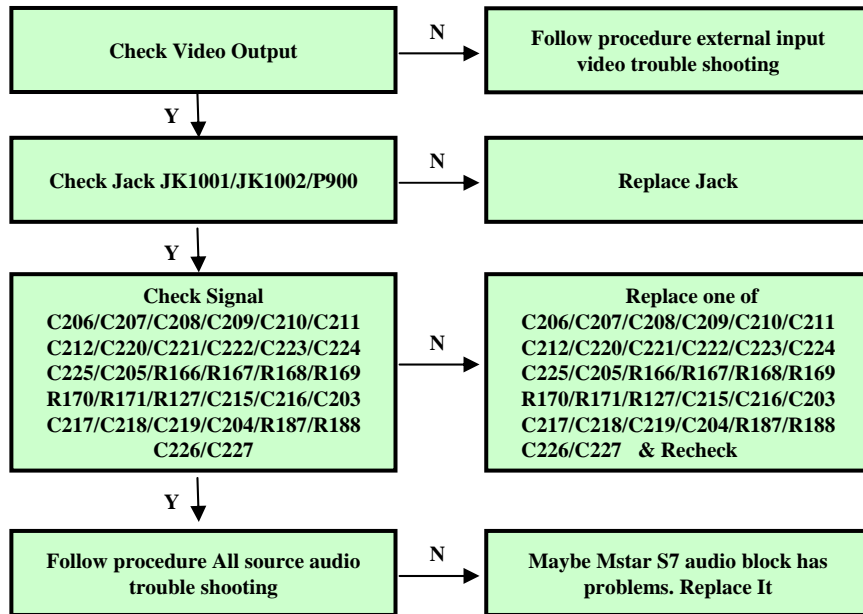

# 13. HDMI Audio Trouble Shooting

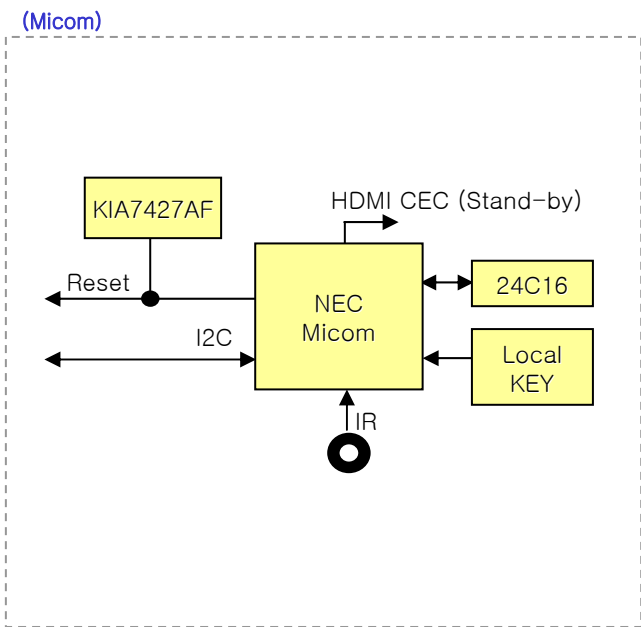
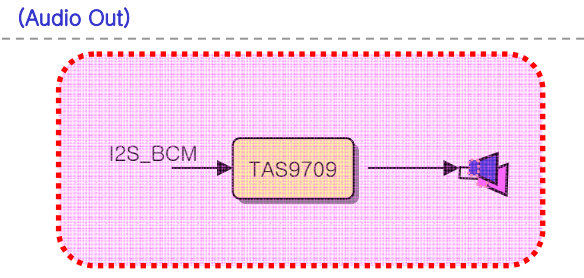
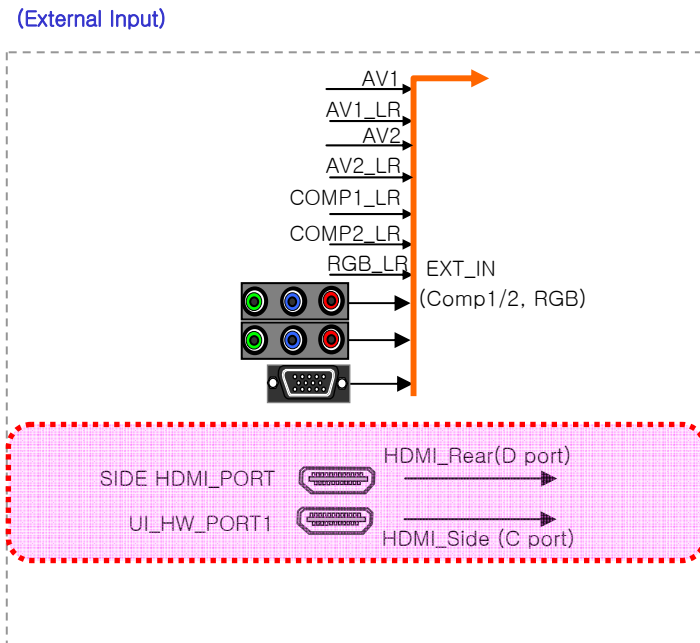
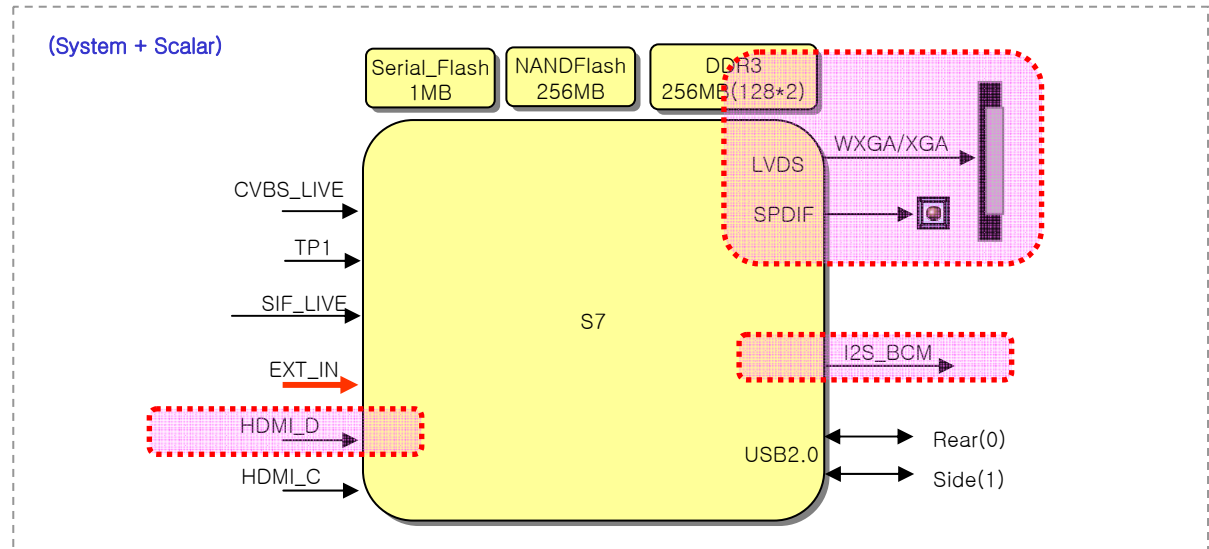
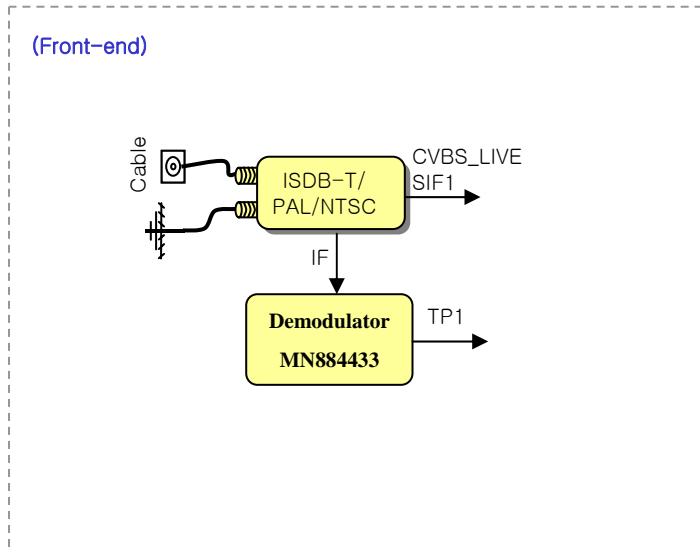

## 13. HDMI Audio Trouble Shooting

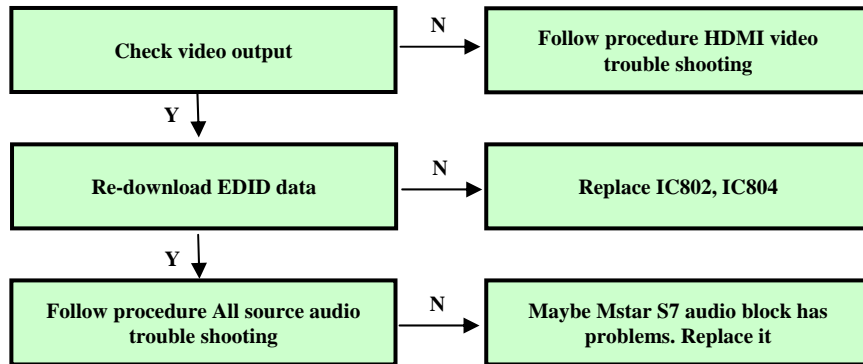

# 14. USB Trouble Shooting

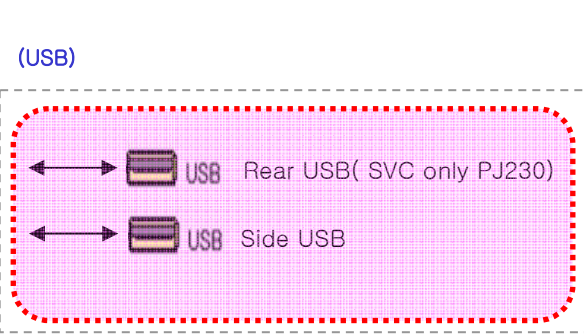
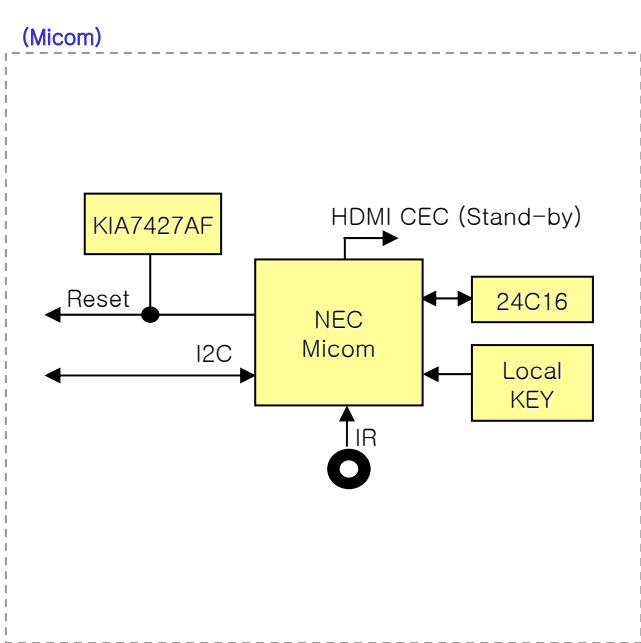
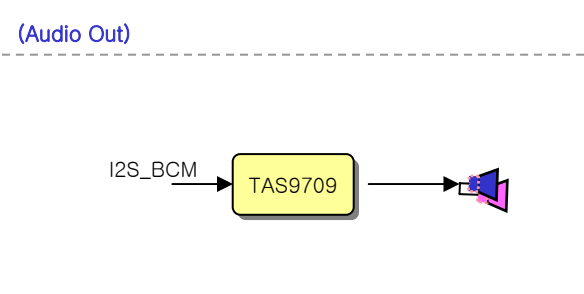
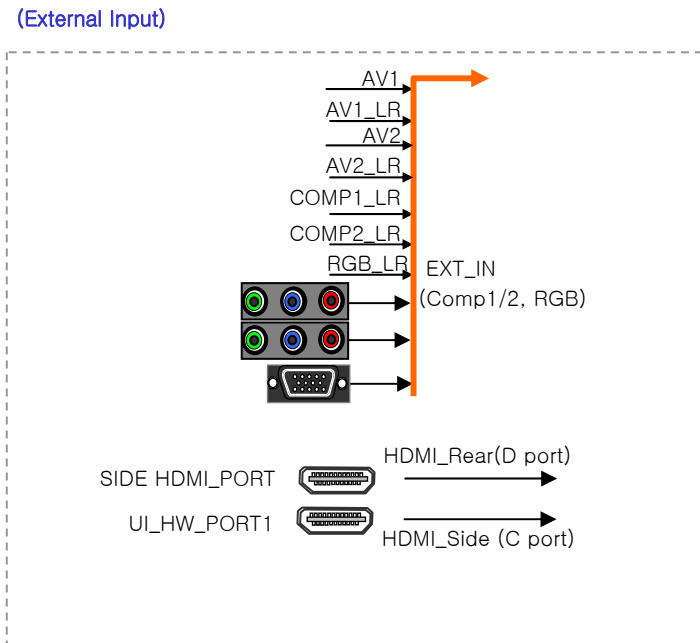
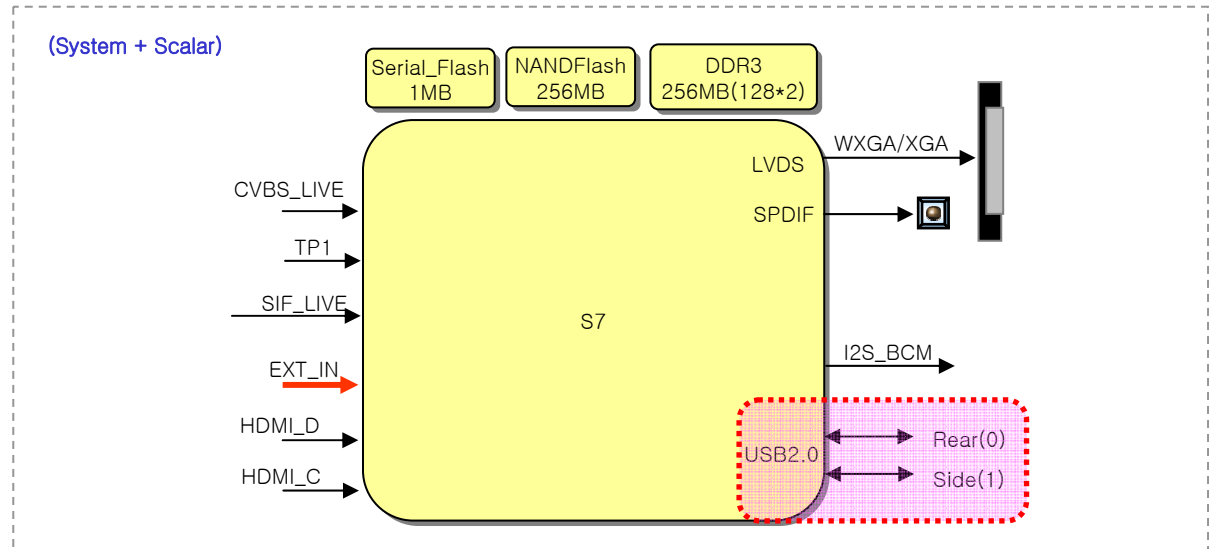
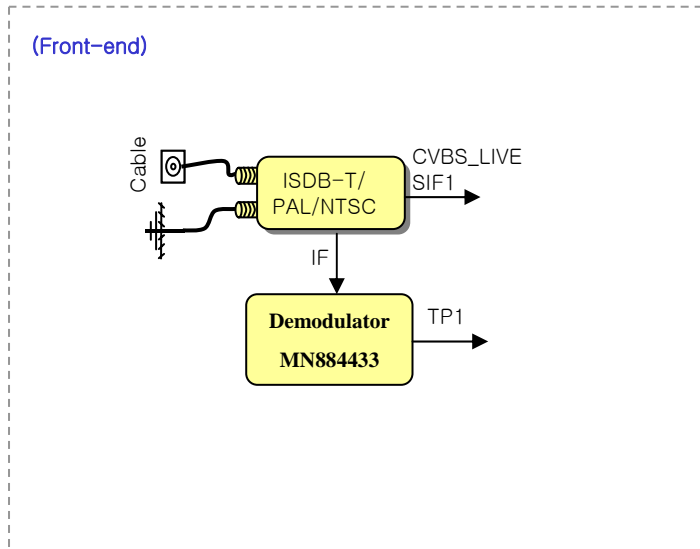

## 14. USB Trouble Shooting

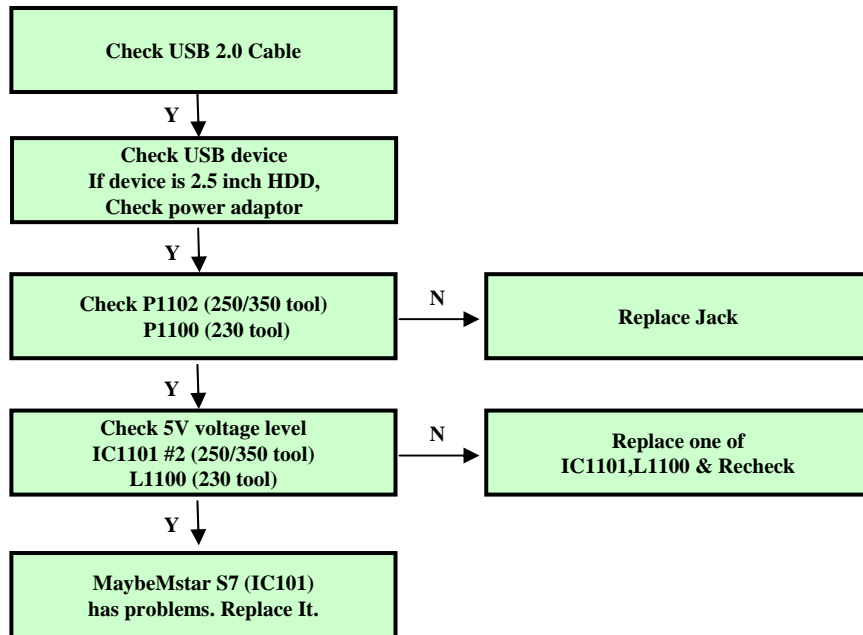

• **Exception**

- USB power could be disabled by inrushing current
- In this case, remove the device and try to reboot the TV (AC power off/on)