

Printer Components

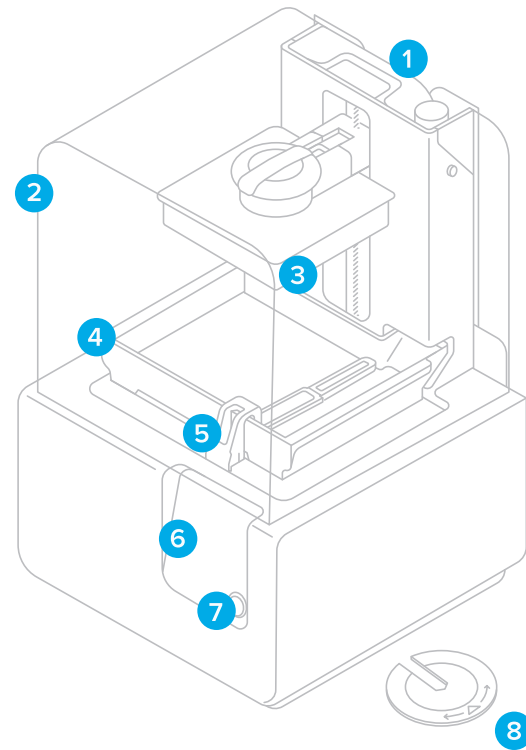

- 1 Cartridge
- 2 Cover
- 3 Build Platform
- 4 Resin Tank
- 5 Wiper
- 6 Touchscreen
- 7 Button
- 8 Leveling Tool

1. Connect Cables

Connect power cable to printer and power supply.

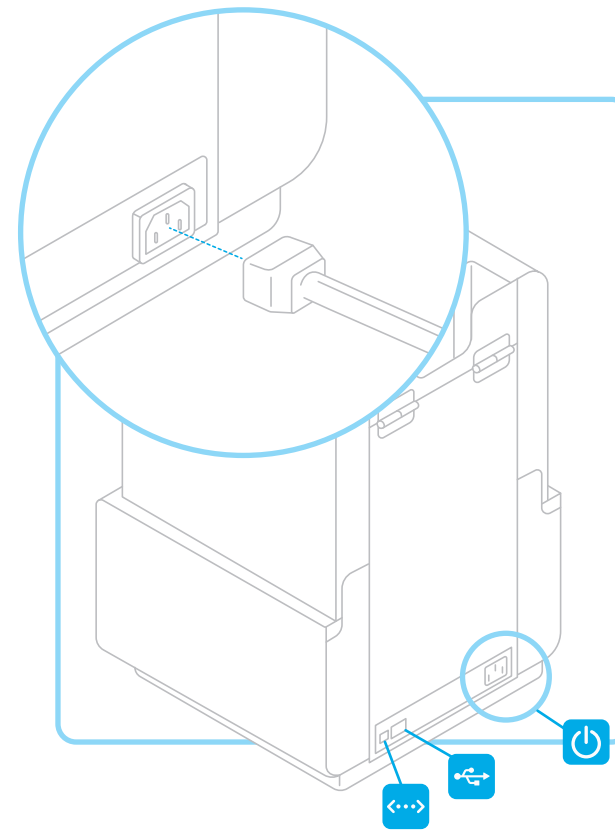

Files can be uploaded via USB, Wifi, or ethernet. For USB, connect the printer to a nearby computer. For ethernet, connect the printer to an ethernet port.

2. Connect to Wifi (Optional)

To connect to Wifi, touch "Wifi" in the settings tab on the touchscreen, then select the name of the network you would like to connect to.

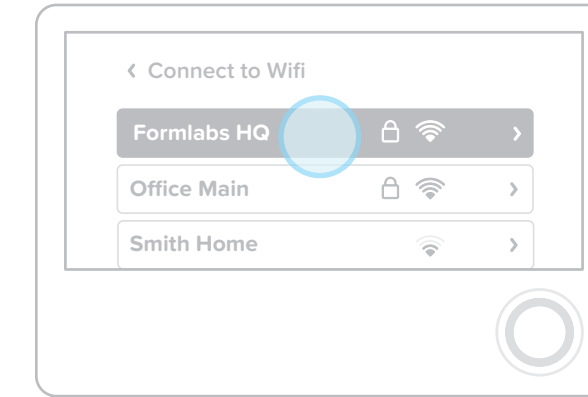

Enter the password for that Wifi network using the on-screen keyboard.

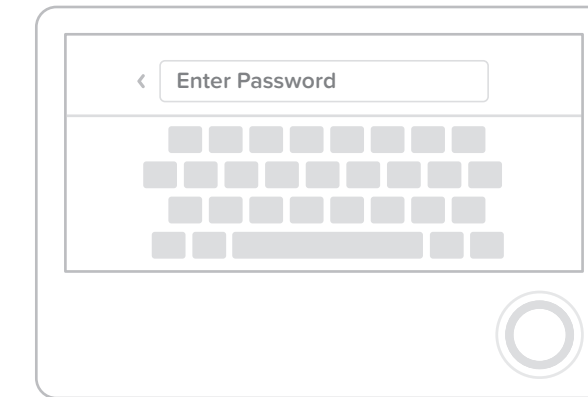

3. Level Printer

If prompted, use the leveling tool to raise or lower each foot of your printer. Adjust the feet until the circle is aligned on the screen.

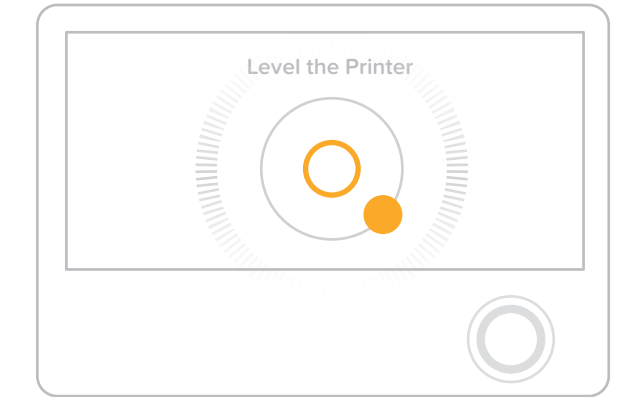

It is important the printer sits level so that resin does not overflow from the tank during printing.

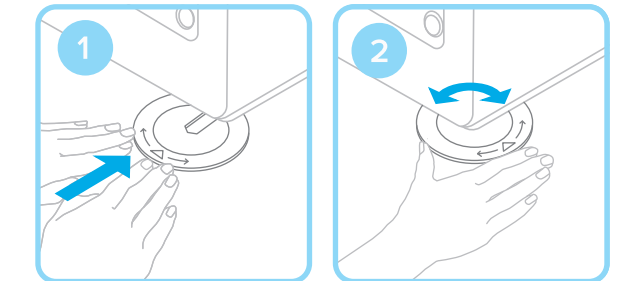

4. Insert Resin Tank with Wiper

Remove the tank lid and align the four small feet of the resin tank with the corresponding holes in the tank carrier; push forward into place.

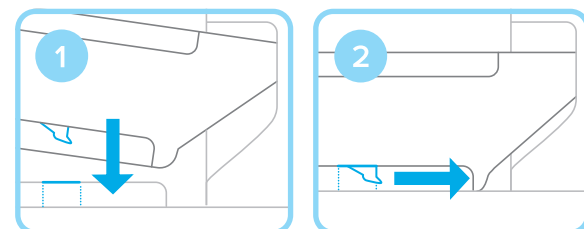
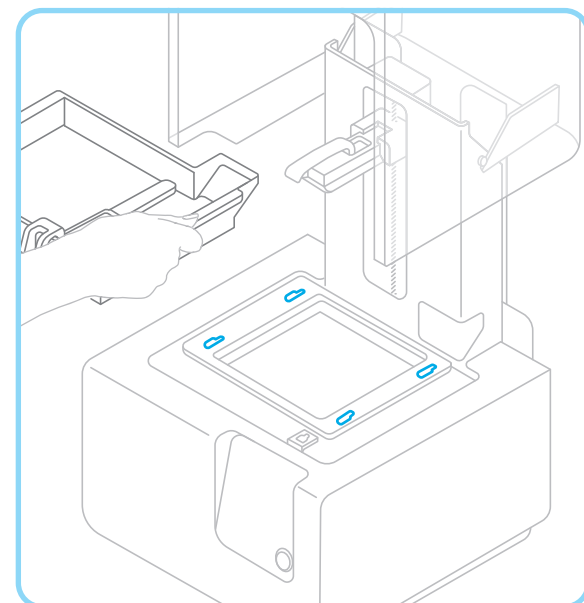

5. Lock Wiper

Ensuring the wiper is straight, align the foot of the wiper with the corresponding hole and push forward, snapping it into place.

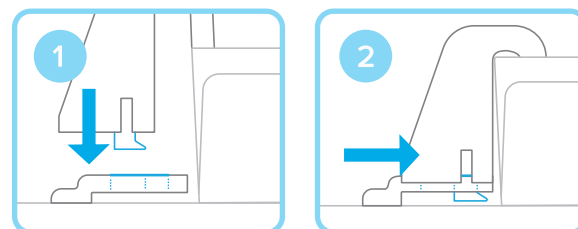
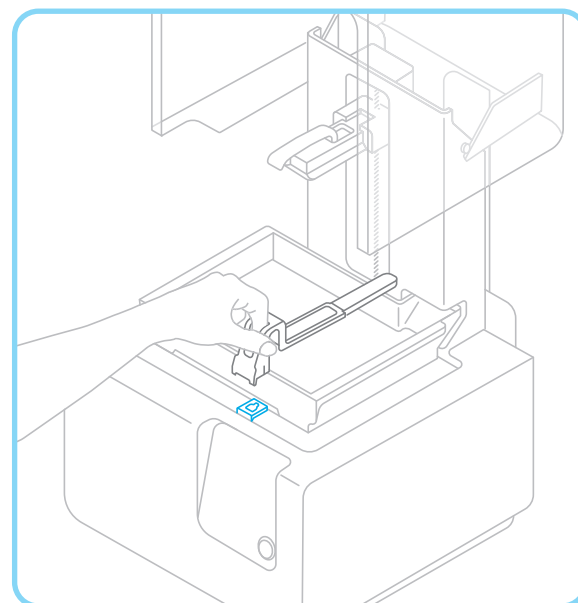

6. Insert Build Platform

Align the build platform with the platform carrier and push it into place, locking the handle down to secure.

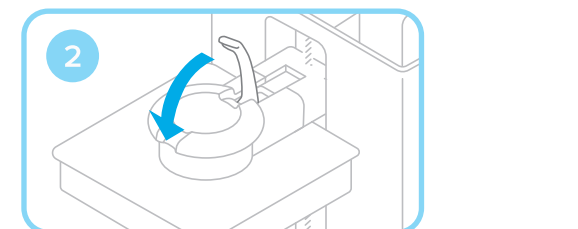
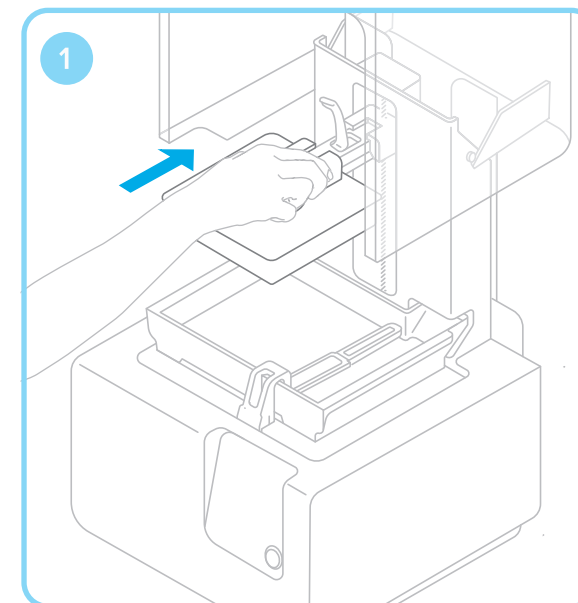

7. Insert Resin Cartridge

Align the cartridge with the opening in the back of the printer. Push down until it sits securely. Be sure to remove the valve cover and press open the cap before starting a print, so that your resin tank fills correctly.

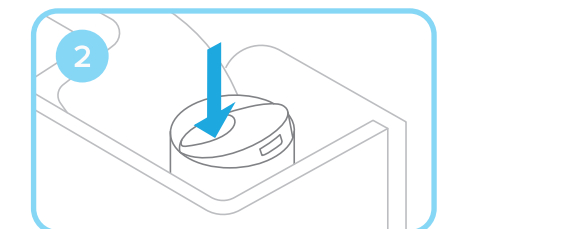
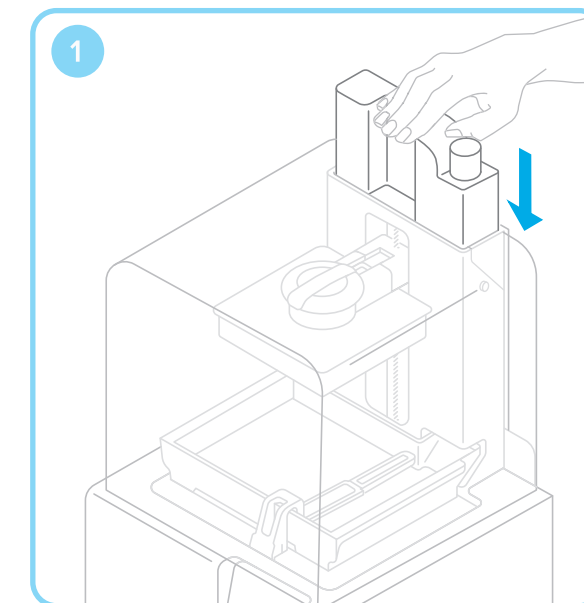

REV 00

8. Download PreForm

Visit our website to download the latest version of our software PreForm.

formlabs.com/products/preform

Opening PreForm, you will see the boundaries of the build volume and the build platform, which is inverted from the print orientation. Click through PreForm Tools to explore basic functions for setting up your print.



- 1 Menu Bar
- 2 PreForm Tools
- 3 Print Set-up
- 4 View Menu
- 5 Info Bar

9. Prepare File for Print

Open your .STL or .OBJ files. Most parts print better when supported at an angle. For automatic set-up, use PreForm Tools to "orient all," "generate all," and "layout all". PreForm will do these steps in sequence if you select "One-Click Print."

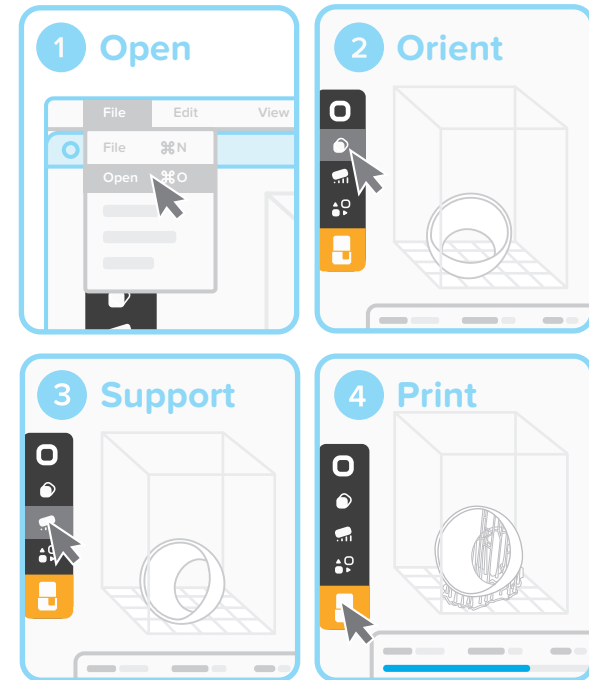

Confirm your print's material and layer height, then click the orange print icon. Select which printer to upload the file to from the printer dialogue.

10. Confirm Print on Printer

You will see your file uploading to the print queue on your printer's touchscreen. Select the file name and confirm the print by pushing the button on your printer.

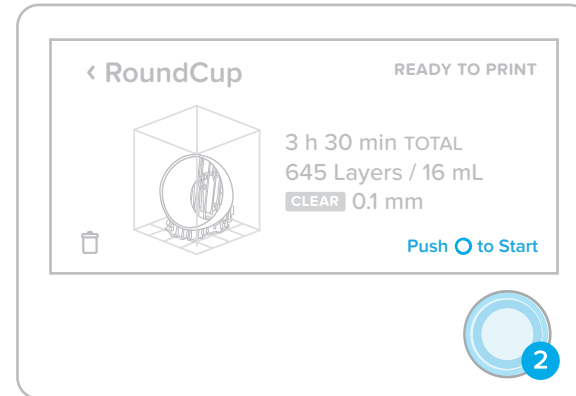
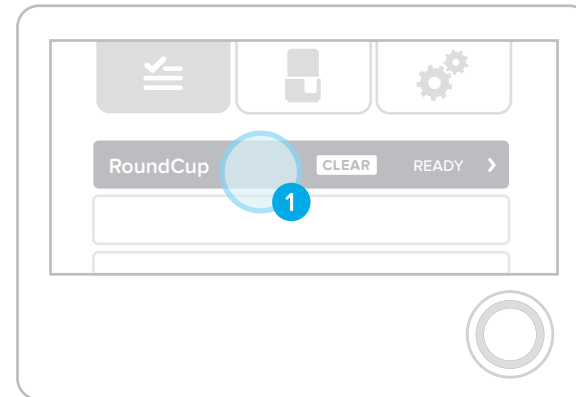

11. Pre-Print Checks

Before printing, the resin tank will fill and heat up to around 35 °C. Once the tank is full, your print will automatically start.

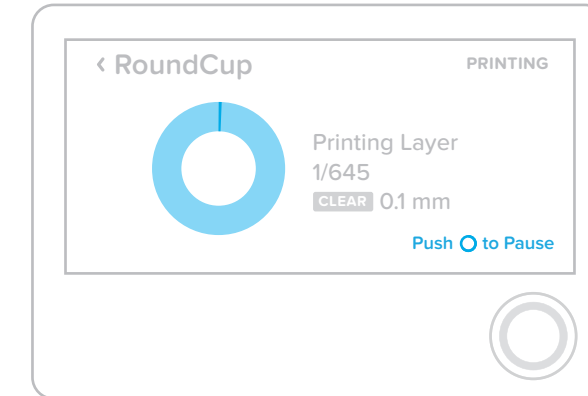
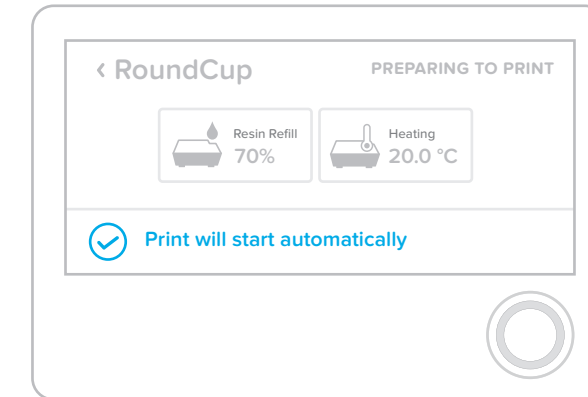

Additional Resources

VISIT OUR WEBSITE FOR:

Video tutorials and more instructions

formlabs.com/support

Fast access to common questions

formlabs.com/faq

Cleaning and caring for your printer

formlabs.com/form2/maintenance

Basic Care

Check that the following are clean and clear:

- ✓ **GLASS OPTICAL WINDOW**
This sits under the tank to protect the internal components. Keep clear of dust and fingerprints.
- ✓ **UNDERSIDE OF THE RESIN TANK**
The laser passes through the clear acrylic of the tank to hit the resin. Keep clean from dust and fingerprints.
- ✓ **INSIDE OF THE RESIN TANK**
Any cured material left in the tank can affect future prints. Check the silicone layer, wiper, and remaining resin to remove any debris.

12. Remove the Build Platform

When your print is finished, wear gloves to remove the build platform. Turn the platform over to prevent dripping while transferring to the finish kit. Make sure to close the printer cover.

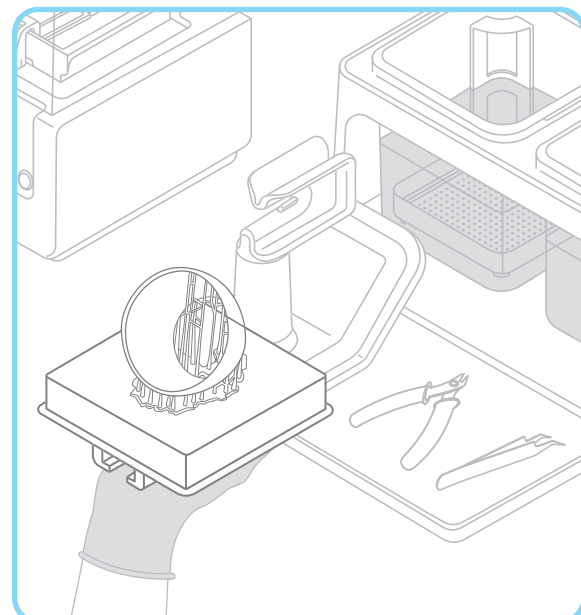
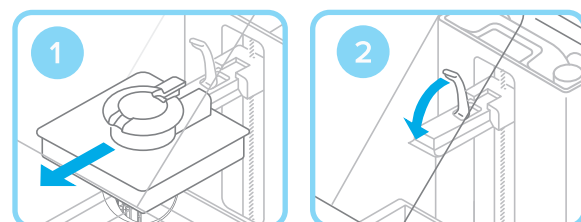

13. Remove Your Print

Attach the build platform to the jig and slide the removal tool under the base of your print to release the part. Use the removal tabs for easy entry points.

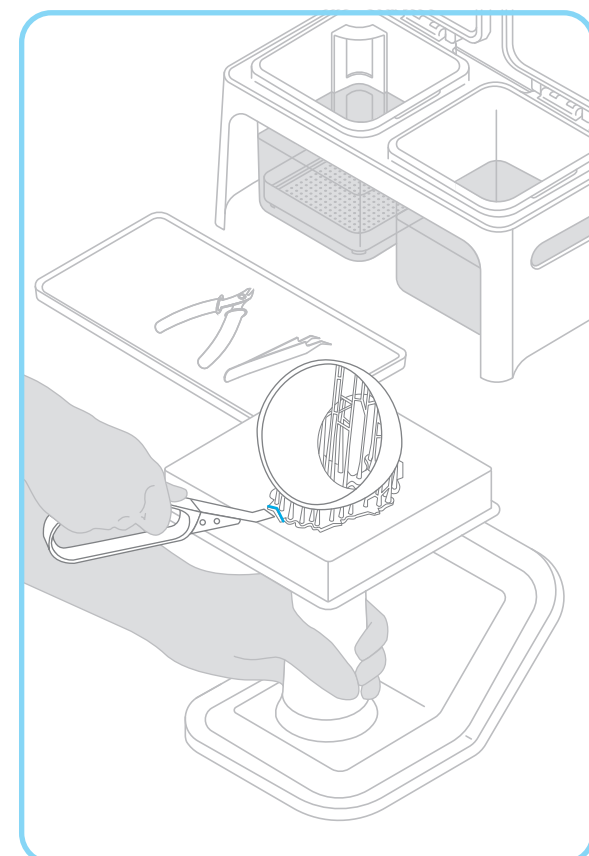

14. Wash Your Print

Fill two rinse buckets with isopropyl alcohol (IPA). Keep the lids closed and keep out of reach of children; IPA is flammable.

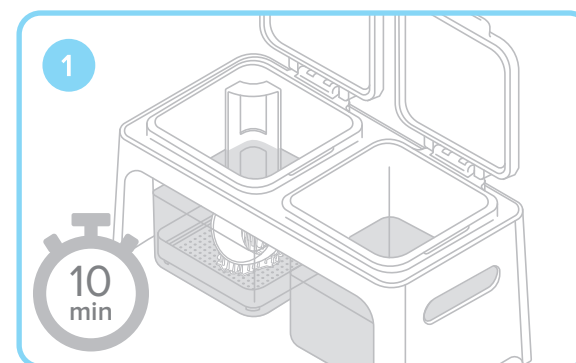

Drop your print in the rinse bucket and leave for 10 minutes. Agitate the part and repeat with the second rinse bucket. This two step process will help your IPA last longer.

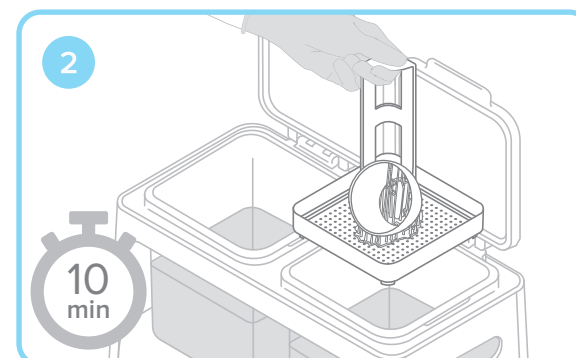

15. Finish Your Print

Once dry, use the flush cutters to remove supports from your print. You can sand support marks and polish your part for a clean finish. You may need to UV post-cure your part if using our Functional Resins.

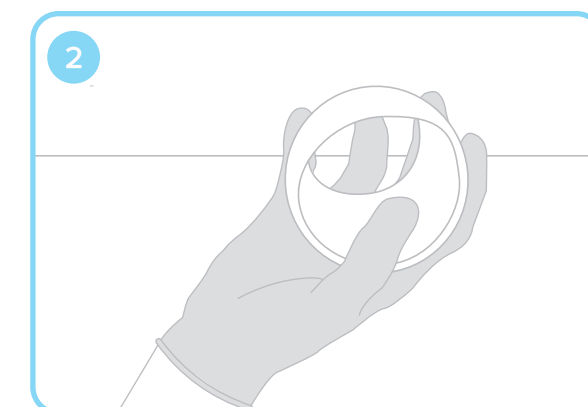
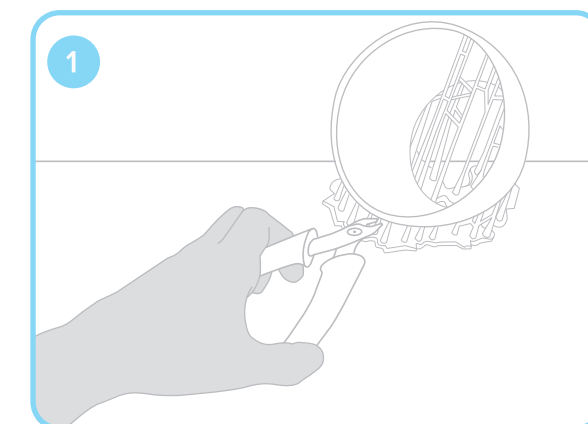

Helpful Supplies

REQUIRED

- Isopropyl Alcohol (IPA), 90% or higher
- Powder-free disposable gloves
- Paper towels

SUGGESTED

- Novus 1 Acrylic cleaner
- Compressed air
- Cotton swabs
- Paint filters, 190 micron mesh

VISIT FORMLABS.COM FOR:

- Chat Support
- Email Support
- Discussion Forums
- Help Articles

This guide is available in other languages on our website.