

# Operating Instructions

## Flowphant<sup>®</sup> T

### DTT31, DTT35

Flow Switch

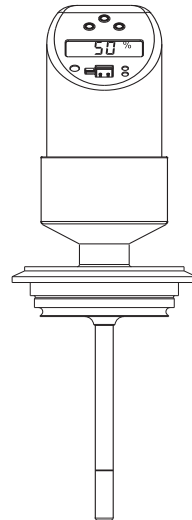
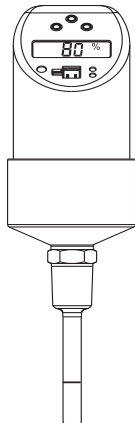

## Brief overview

For quick and easy commissioning:

<b>Safety instructions</b>	→ Page 4
▼	
<b>Installation</b>	→ Page 7
▼	
<b>Wiring</b>	→ Page 12
▼	
<b>Operation</b>	→ Page 13
Display and operating elements Onsite operation Operation with PC and configuration software	
▼	
<b>Troubleshooting</b>	→ Page 31

## Table of contents

<b>1</b>	<b>Safety instructions</b> . . . . .	<b>4</b>	<b>9</b>	<b>Technical data</b> . . . . .	<b>34</b>
1.1	Designated use . . . . .	4	9.1	Power supply . . . . .	34
1.2	Installation, commissioning and operation . . . . .	4	9.2	Output . . . . .	34
1.3	Operational safety . . . . .	4	9.3	Operating conditions . . . . .	35
1.4	Return . . . . .	4			
1.5	Notes on safety conventions and icons . .	5			
<b>2</b>	<b>Device identification</b> . . . . .	<b>6</b>			
2.1	Nameplate . . . . .	6			
2.2	Certificates and approvals . . . . .	6			
<b>3</b>	<b>Installation</b> . . . . .	<b>7</b>			
3.1	Incoming acceptance, storage . . . . .	7			
3.2	Dimensions . . . . .	7			
3.3	Process connection . . . . .	8			
3.4	Installation instructions . . . . .	10			
<b>4</b>	<b>Wiring</b> . . . . .	<b>12</b>			
4.1	DC voltage version with M12x1 connector . . . . .	12			
4.2	DC voltage version with valve connector	13			
<b>5</b>	<b>Operation</b> . . . . .	<b>13</b>			
5.1	Onsite operation . . . . .	13			
5.2	Operation with PC and configuration software . . . . .	25			
<b>6</b>	<b>Maintenance</b> . . . . .	<b>26</b>			
<b>7</b>	<b>Accessories</b> . . . . .	<b>27</b>			
7.1	Welding bosses and coupling . . . . .	27			
7.2	Electrical connection . . . . .	28			
7.3	Configuration kit . . . . .	29			
7.4	Configuration software . . . . .	30			
<b>8</b>	<b>Troubleshooting</b> . . . . .	<b>31</b>			
8.1	Error messages and warning messages	31			
8.2	Repair . . . . .	32			
8.3	Disposal . . . . .	32			
8.4	Change status (release) . . . . .	33			
8.5	Software history . . . . .	33			

# 1 Safety instructions

## 1.1 Designated use

The Flowphant® T is a flow switch for monitoring mass flow rates in industrial processes. The device is designed to meet state-of-the-art safety requirements and conforms to applicable standards and EC regulations. It can, however, be a source of danger if used incorrectly or for anything other than the designated use.

## 1.2 Installation, commissioning and operation

Installation, electrical connection, commissioning, operation and maintenance of the measuring system must be carried out by trained, qualified specialists authorized to perform such work by the facility's owner-operator. The specialist must have read and understood these Operating Instructions and must follow the instructions they contain. The device may only be modified and repair work carried out if this is explicitly permitted in the Operating Instructions. Damaged devices which could be a source of danger may not be commissioned and must be labeled and identified as defective.

## 1.3 Operational safety

- **Functional safety**  
The Flowphant® T flow switch has been developed in accordance with the IEC 61508 and IEC 61511-1 (FDIS) standards. The device version with a PNP switch output and additional analog output is equipped with features for detecting and preventing errors within the electronics and software.
- **Ex-area**  
The Flowphant® T is not approved for use in Ex-areas.

## 1.4 Return

The following procedures must be carried out before a device is returned to Endress+Hauser:





- Always enclose a fully completed “Declaration of Contamination” form with the device. Only then can Endress+Hauser transport and examine a returned device. A copy of the “Declaration of Contamination” can be found on the second last page of these Operating Instructions.
- Remove all fluid residues. This is particularly important if the fluid is hazardous to health, e.g. flammable, toxic, caustic, carcinogenic, etc.

### **⚠ WARNING**

**Do not return a device if you are not absolutely certain that all traces of hazardous substances have been removed, e.g. substances which have penetrated crevices or diffused through plastic.**

## 1.5 Notes on safety conventions and icons

Always refer to the safety instructions in these Operating Instructions labeled with the following symbols:

Symbol	Meaning
 <small>A0011190-EN</small>	<b>WARNING!</b> This symbol alerts you to a dangerous situation. Failure to avoid this situation can result in serious or fatal injury.
 <small>A0011191-EN</small>	<b>CAUTION!</b> This symbol alerts you to a dangerous situation. Failure to avoid this situation can result in minor or medium injury.
 <small>A0011192-EN</small>	<b>NOTICE</b> This symbol contains information on procedures and other facts which do not result in personal injury.
 <small>A0011193</small>	Indicates additional information, Tip

## 2 Device identification

### 2.1 Nameplate

To identify your device, compare the complete order code and the version information on the delivery papers with the data on the nameplate.

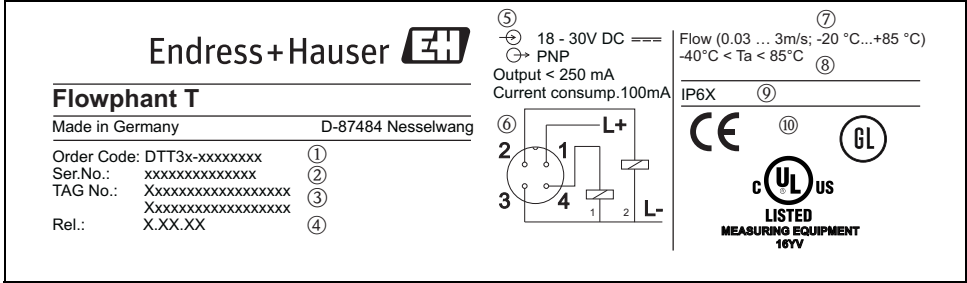

Fig. 1: Nameplate for device identification (as example)

A0006981

①	Order code	⑥	Connection diagram
②	Serial number	⑦	Measuring range
③	TAG number	⑧	Ambient temperature range
④	Release number (change status)	⑨	Degree of protection
⑤	Connection values	⑩	Approvals



The release number indicates the change status of the device. A change in the last two figures does not have any affect on the compatibility, → Chap. 8.4.

### 2.2 Certificates and approvals

#### CE mark, declaration of conformity

On leaving the factory, the device was in perfect condition from the point of view of safety. It complies with the standards EN 61010 -1 "Protection Measures for Electrical Equipment for Measurement, Control, Regulation and Laboratory Procedures" and with the EMC requirements of IEC/EN 61326. The device meets the legal requirements of the EU Directives. The manufacturer confirms a positive completion of all tests by fitting the unit with a CE mark.

#### Hygiene standard

The DTT35 flow switch meets the requirements of Sanitary Standard no. 74-06. Endress+Hauser confirms this by applying the 3-A symbol (not valid for process connection conical metal-metal).

**UL listed for Canada and USA**

The device was examined by Underwriters Laboratories Inc. (UL) in accordance with the standards UL 61010B-1 and CSA C22.2 No. 1010.1-92 and listed under the number E225237 UL.

**3 Installation**

**3.1 Incoming acceptance, storage**

- Incoming acceptance:
  - Check the packaging and the device for damage. Check that the goods delivered are complete and nothing is missing.
- Storage:
  - Storage temperature -40 °C to +85 °C (-40 °F to 185 °F).

**3.2 Dimensions**

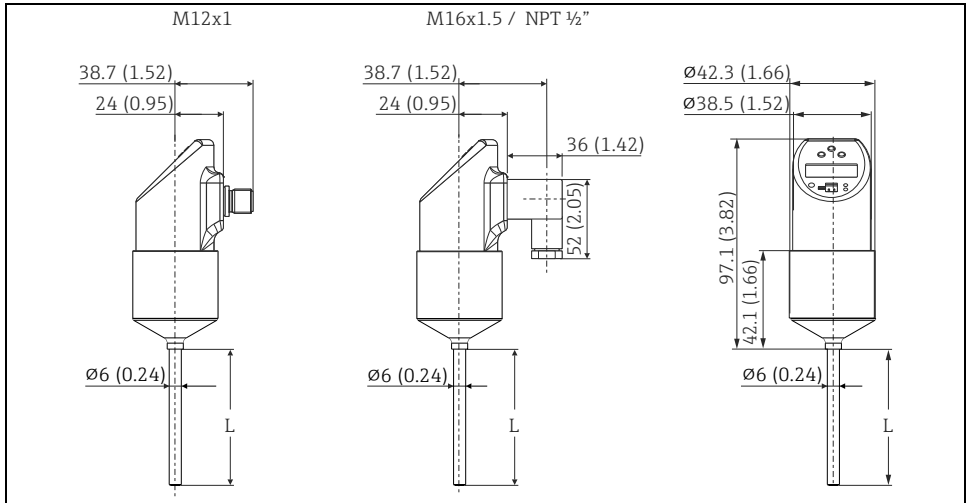

Fig. 2: Dimensions in mm (in)

Version L with 30 and 100 mm (1.18 and 3.94 in) for DTT31  
 Version L with 30, 50 and 100 mm (1.18, 1.97 and 3.94 in) for DTT35  
 M12x1 connector as per IEC 60947-5-2  
 M16x1.5 or NPT 1/2" valve connector as per DIN 43650A/ISO 4400

### 3.3 Process connection

#### 3.3.1 DTT31 design, dimensions of the process connections

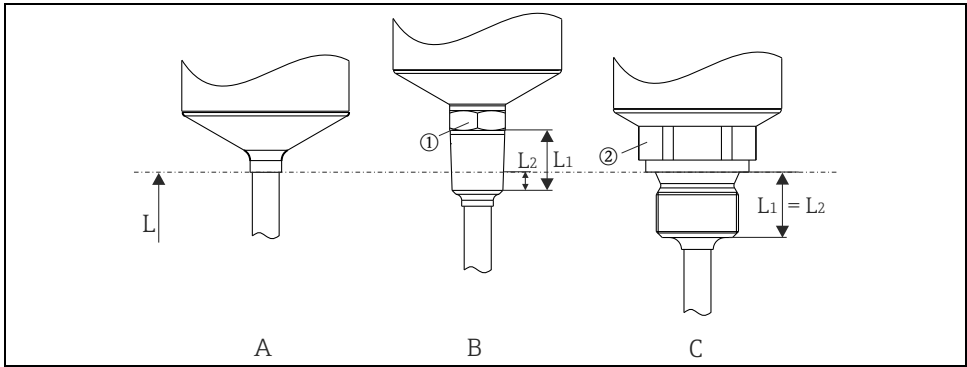

Fig. 3: Process connection versions of DTT31

A0007101

Item no.	Version	Insertion length L	Thread length $L_1$	Thread length $L_2$
A	Without process connection. For suitable welding boss and coupling see chapter 'accessories'.		-	-
B	Thread process connection: <ul style="list-style-type: none"> <li>■ ANSI NPT 1/4" (① = AF15)</li> <li>■ ANSI NPT 1/2" (① = AF22)</li> </ul>	30 or 100 mm (1.18 or 3.94 in)	<ul style="list-style-type: none"> <li>■ 14.3 mm (0.56 in)</li> <li>■ 19 mm (0.75 in)</li> </ul>	<ul style="list-style-type: none"> <li>■ 5.8 mm (0.23 in)</li> <li>■ 8.1 mm (0.32 in)</li> </ul>
C	Thread process connection cylindrical as per ISO 228: <ul style="list-style-type: none"> <li>■ G1/4" (② = AF19)</li> <li>■ G1/2" (② = AF27)</li> </ul>		<ul style="list-style-type: none"> <li>■ 12 mm (0.47 in)</li> <li>■ 14 mm (0.55 in)</li> </ul>	-



### 3.3.2 DTT35 design, dimensions of the process connections

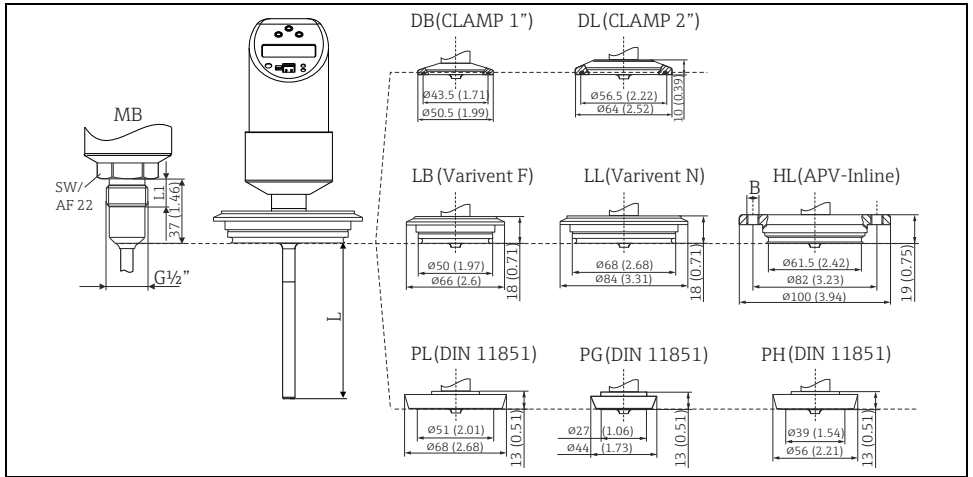

Fig. 4: Hygienic process connections. All dimensions in mm (in)

L = Insertion length L

Item no.	Process connection versions DTT35 Insertion length L = 30, 50 or 100 mm (1.18, 1.97 or 3.94 in)
MB	Conical metal-metal for hygienic processes, G $\frac{1}{2}$ " thread, thread length L1 = 14 mm (0.55 in). Suitable welding boss available as accessory.
DB	Clamp 1" $1\frac{1}{2}$ " (ISO 2852) or DN 25...DN 40 (DIN 32676)
DL	Clamp 2" (ISO 2852) or DN 50 (DIN 32676)
LB	Varivent F DN25-32, PN 40
LL	Varivent N DN40-162, PN 40
HL	APV-Inline, DN50, PN40, 316L, B = bores 6 x $\varnothing 8.6$ (0.34 in) + 2 x thread M8
PL	DIN 11851, DN50, PN40 (including coupling nut)
PG	DIN 11851, DN25, PN40 (including coupling nut)
PH	DIN 11851, DN40, PN40 (including coupling nut)



The maximum process pressure for the conical metal-metal process connection (→ Fig. 4, item MB) is 16 bar!

## 3.4 Installation instructions

### 3.4.1 Installation conditions



The sensor requires a fully developed flow profile for correct monitoring.

For this reason, steadying sections ( $5 \times \text{DN}$ ) must be provided in the pipe after a pump, pipe bend, internal fittings and cross-sectional changes.

#### NOTICE

Do not turn the device into the process connection thread at the housing. Always install the device at the spanner flats (**Fig. 5**, item 1). Use a suitable open-ended wrench for this task (see Table → **Chap. 3.3.1**).

- The onsite display can be rotated electronically  $180^\circ$ , → Chap. 5.1 "Onsite operation".
- The upper housing section can be rotated mechanically up to  $310^\circ$ .

- The sensor tip should be completely surrounded by medium.
- Position the sensor tip in the area of maximum fluid velocity (pipe center).
- Minimum sensor immersion length:  $L_1 \geq 10 \text{ mm}$ .

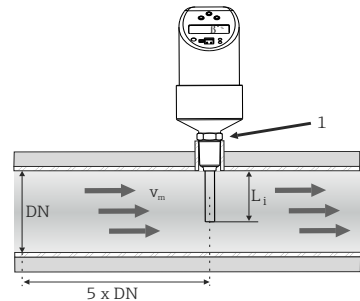

A0006976

Fig. 5: Installation conditions

#### Orientation

- For horizontal pipes: lateral installation.  
Installation from above (see Fig. 5) **only** if the pipe is completely filled with medium during operation.
- For vertical pipes: installation in the ascending pipeline.
- Installation of DTT35 by min.  $3^\circ$  inclination, because of self draining.

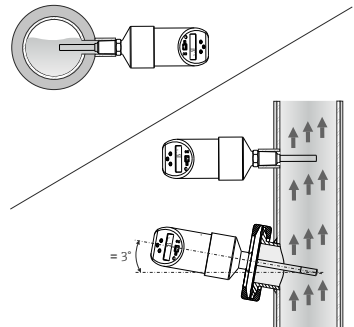

A0006977

Fig. 6: Correct orientation

**NOTICE**

Do not install in down pipes open towards the end.  
The sensor tip should never touch the pipe wall.

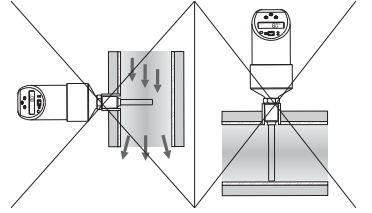

Fig. 7: Incorrect installation!

A0006978

**3.4.2 Mounting instructions for installation in hygienic processes**

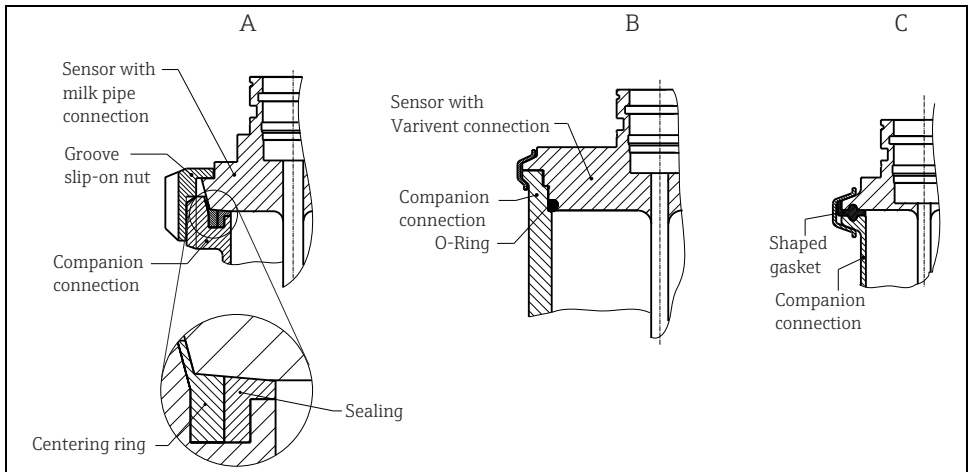

Fig. 8: Installation in hygienic processes

A0011673-EN

- A Milk pipe connection as per DIN 11851 (connection PL, PG, PH), only in linkage with EHEDG certified and self centering ring
- B Varivent and APV-Inline (connection LB, LL, HL)
- C Clamp as per ISO 2852 (connection DB, DL)

## 4 Wiring



DTT35: Electrical cables must comply with 3-A standard.  
They must be smooth, corrosion resistant and cleanable.

### 4.1 DC voltage version with M12x1 connector

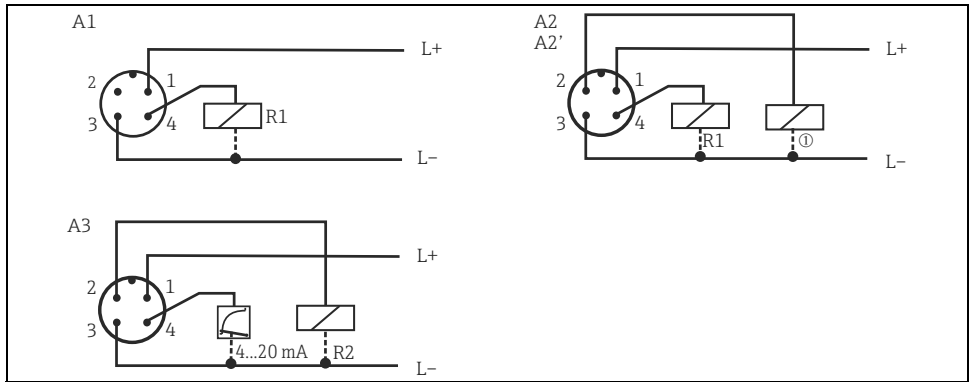

A0006818

*Flowphant® T with M12x1 connector*

A1: 1x PNP switch output

A2: 2x PNP switch outputs R1 and m (R2)

A2': 2x PNP switch output R1 and m (diagnosis/NC contact for "DESINA" setting)

A3: 1x PNP switch output and 1x analog output (4 to 20 mA)

#### ⚠ CAUTION

To avoid any damage to the analog input of a PLC, do not connect the active PNP switch output of the device to the 4 to 20 mA input of a PLC.

DESINA (→ Chap. 5.1.6, basic settings):

R2 = diagnosis/NC contact (more information on DESINA can be found at [www.desina.de](http://www.desina.de)).

#### NOTICE

Once connected to the power supply, the sensor tip of the device heats up! The temperature can reach up to approx. 90 °C (194 °F).

## 4.2 DC voltage version with valve connector

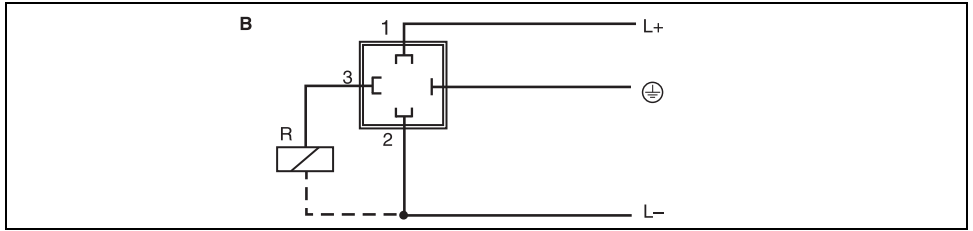

P01-PTX3xxxx-04-xx-xx-xx-003

Fig. 9: Flowphant® T with M16x1.5 valve connector or NPT 1/2"

B: 1x PNP switch output

## 5 Operation

### 5.1 Onsite operation

The Flowphant® T is operated by means of three keys. The digital display and the light emitting diodes (LED) support navigation in the operating menu.

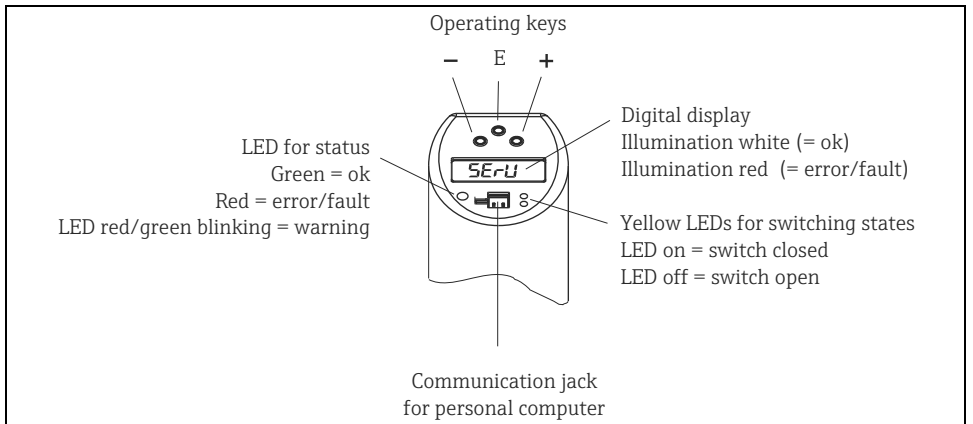

A0020825-EN

Fig. 10: Position of operating elements and possibilities for display

### 5.1.1 Navigating in the operating menu

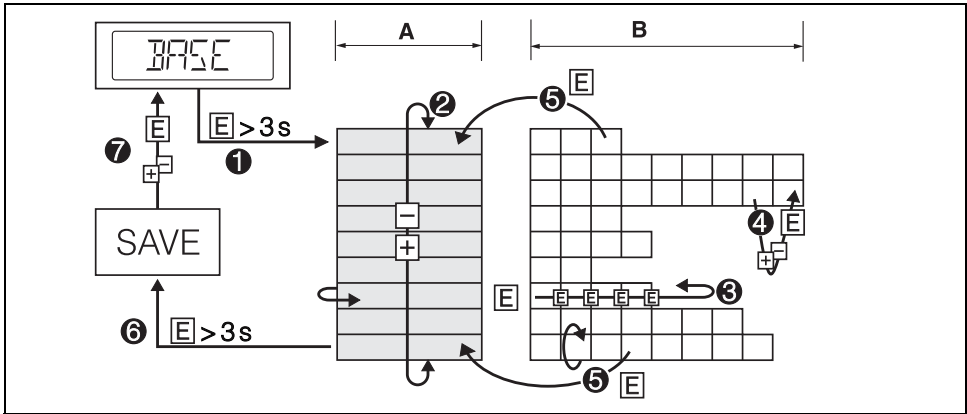

T09-TTR31.xxx-19-xx-xx-xx-002

Fig. 11: Navigating in the operating menu

A Function group selection

B Function selection

- ➊ Enter the operating menu  
-Press the E key for longer than 3 s
- ➋ Select the "Function group" with the + or -key
- ➌ Select the "Function" with the E key
- ➍ Enter or change parameters with the + or -key  
-Then return to "Function" with the E key Note: If software locking is enabled, it must be disabled before making entries or changes
- ➎ Return to the "Function group" by pressing the E key several times  
-until the appropriate function group is reached again
- ➏ Jump to the measuring position (Home position)  
-Press the E key for longer than 3 s
- ➐ Query to save data (select "YES" or "NO" with the + or -key)  
-Confirm with the E key



Changes to the parameter settings only become effective if you choose s 'YES' when asked to save data.

### 5.1.2 Navigating the Calibration function group (CAL)

Variable limits for HIF (Learn High Flow) or LOWF (Learn Low Flow) can be configured using the 'Learn' function.

- HIF configuration (Learn High Flow): Enter a random flow rate between 70% and 100% of the maximum value in the process. The measuring device uses this value to automatically calculate the corresponding 100% value.
- LOWF configuration (Learn Low Flow): Enter a random flow rate between 0% and 20% of the maximum value in the process. The measuring device uses this value to automatically calculate the corresponding 0% value.

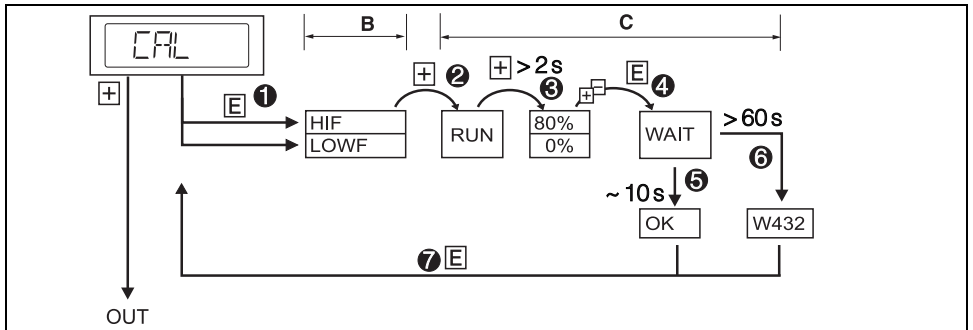

Fig. 12: Navigating the 'Learn' function using the Calibration (CAL) function group as an example

A00107B7

#### B Select function

- ➊ Select the HIF (Learn High Flow) or LOWF (Learn Low Flow) function with the E key

#### C Select settings

- ➋ Select the "RUN" function with the + key, 'Learn' function is initialized
- ➌ Select the flow rate with the + key, press for longer than 2 s:
  - If the HIF is configured (Learn High Flow), the upper flow rate (70% - 100%) is selected. Enter the current relative flow rate in increments of 1% with the + or - key (factory setting 80%).
  - If the LOWF is configured (Learn Low Flow), the lower flow rate (0% - 20%) is selected. Enter the current relative flow rate in increments of 1% with the + or - key (factory setting 0%).
- ➍ Select the "WAIT" function with the E key
- ➎ Accept ('Learn') the current measured value after approx. 10 s - "OK" appears on the display
- ➏ Or: The message "W432" appears on the display after 60 s
  - A sufficiently stable flow rate was not detected during the learning process. The system takes an average of the 10 values last measured during the learning process.
- ➐ Return to the CAL function group (Home position) with the E key



The device is still operative if message W432 appears. There can be large measuring uncertainties however. Recommendation: Repeat 'Learn' process (points 1 to 4) until "OK" appears on the display.

### 5.1.3 Navigating the 'Learn' switch point (SPL)

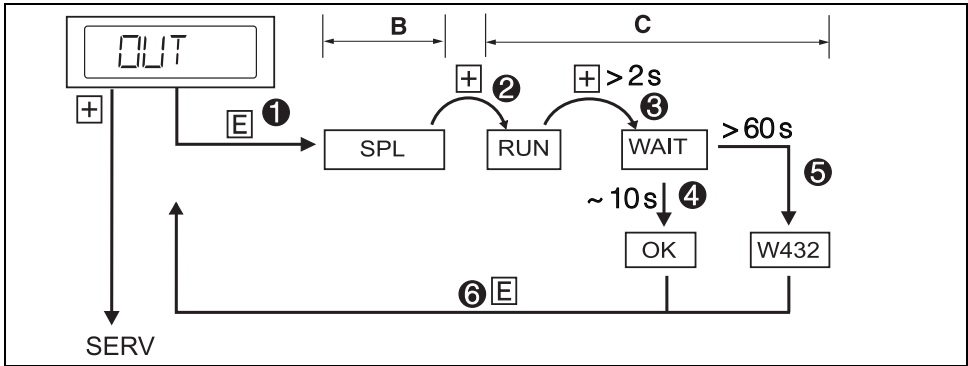

Fig. 13: Navigating the 'Learn' switch point

A0005785

#### B Select function

- 1 SPL ('Learn' switch point), optional SPL2 ('Learn' switch point 2) with the E key

#### C Select settings

- 2 Select the "RUN" function with the + key, 'Learn' function is initialized
- 3 Select the "WAIT" function with the + key, press for longer than 2 s
- 4 Accept ('Learn') the current measured value after approx. 10 s - "OK" appears on the display
- 5 Or: The message "W432" or "NOK" appears on the display after 60 s
  - W432: A sufficiently stable flow rate was not detected during the learning process. The system takes an average of the 10 values last measured during the learning process.
  - NOK: The switch point determined is under 5% of the measuring range and cannot be accepted as the switch point must be a min. of 5% greater than the switch-back point (RSP).
- 6 Return to the OUT function group (Home position) with the E key



The device is still operative if message "W432" or "NOK" appears. However, large deviations at the switch point may result. Recommendation: Repeat 'Learn' process (points 1 to 4) until "OK" appears on the display.



### 5.1.4 Structure of the operating menu for 2 switch outputs

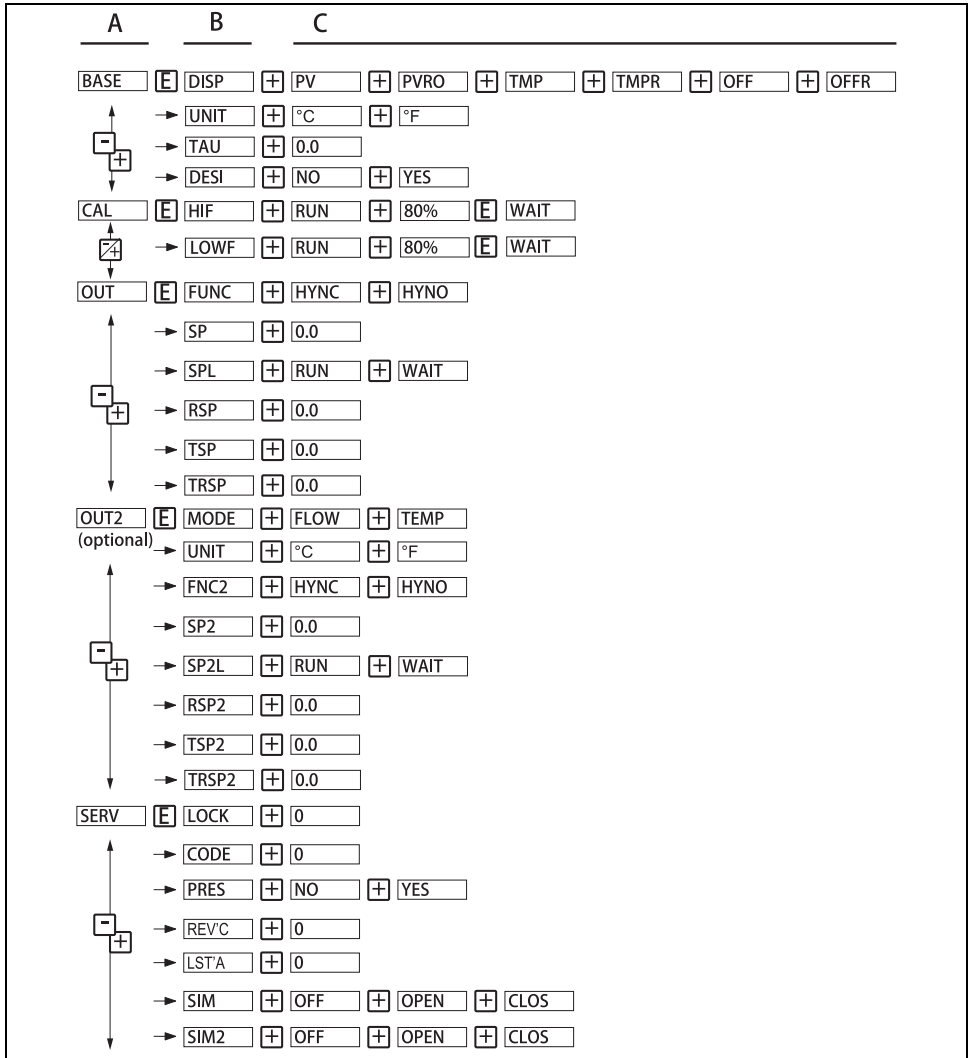
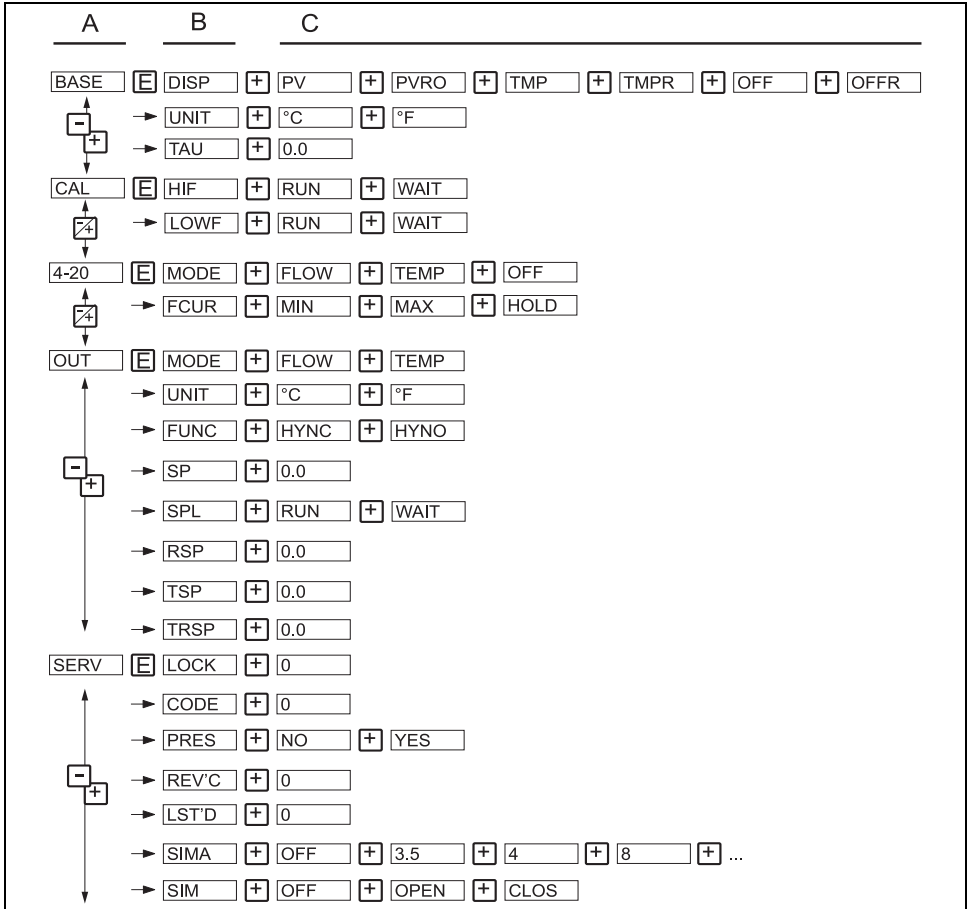

Fig. 14: Operating menu: A function groups, B functions, C settings

A0005784

**5.1.5 Structure of the operating menu for 1 x analog output (4 to 20 mA) and 1 x switch output.**



A0006819

Fig. 15: Operating menu: A function groups, B functions, C settings

### 5.1.6 Basic settings

Function group	Function		Settings	Description
<b>BASE</b> Basic settings	<b>DISP</b>	Display	<b>PV</b> <b>PVRO</b> <b>TMP</b> <b>TMPR</b> <b>OFF</b> <b>OFFR</b>	PV: displays the current measured value PVRO: displays the current measured value rotated 180° TMP: displays the current medium temperature TMPR: displays the current medium temperature rotated 180° OFF: display off OFFR: display off, rotated 180°  Factory setting: <b>current measured value (PV)</b>
	<b>UNIT</b>	Technical unit	<b>×C</b> <b>×F</b>	Display medium temperature unit °C or °F Factory setting: °C   Only visible if the current medium temperature TMP is selected in the DISP mode.
	<b>TAU</b>	Damping	<b>0.0</b>	Measured value damping with regard to display value and output: 0 (no damping) or 9 to 40 s (in increments of 1 second) Factory setting: <b>0 s</b>
	<b>DESI</b>	DESINA Only for 2 x PNP switch outputs	<b>NO</b> <b>YES</b>	Behavior as per DESINA: PIN assignment of the M12 connector is in accordance with the guidelines of DESINA (DESINA = DistributEd and Standardized INstAllation technology for machine tools and manufacturing systems) Factory setting: <b>NO</b>

### 5.1.7 Calibration

Function group	Function		Settings	Description
<b>CAL</b> Calibration	<b>HIF</b>	Learn High Flow	<b>RUN</b> <b>WAIT</b>	RUN, WAIT: setting for the maximum flow rate occurring. 100% value (→ Page 15)
	<b>LOWF</b>	Learn Low Flow	<b>RUN</b> <b>WAIT</b>	RUN, WAIT: setting for the minimum flow rate occurring. 0% value (→ Page 15)

### 5.1.8 Settings for output - 2 x switch output

#### Functions of the switch point

- **Hysteresis function**  
 The hysteresis function enables two-point control via a hysteresis. Depending on the mass flow, the hysteresis can be set via the switch point SP and the switch-back point RSP.
- **NO contact or NC contact**  
 This switch function is freely selectable.
- **Delay times for switch point SP and switch-back point** can be set in increments of 1 s. By this means undesirable temperature peaks of short duration or of high frequency can be filtered out.

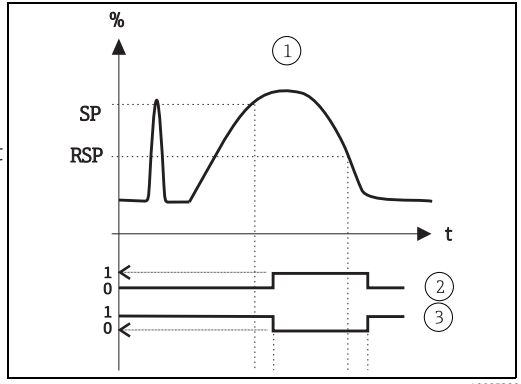







Fig. 16: ① Hysteresis function, ② NO contact, ③ NC contact  
 SP switch point; RSP switch-back point

Function group	Function		Settings	Description
<b>OUT</b> Output 1 <b>OUT2</b> Output 2, optional	<b>MODE</b>	Switching mode	<b>FLOW</b> <b>TEMP</b>	Output switching mode for channel 2 FLOW: flow rate or TEMP: temperature Factory setting: <b>FLOW</b>
	<b>UNIT</b>	Technical unit	× <b>C</b> × <b>F</b>	Temperature unit selection °C or °F ⓘ Function only visible if the switching mode MODE is set to temperature TEMP in the 2nd output. Factory setting: °C

Function group	Function		Settings	Description
<b>OUT/OUT2</b> continued	<b>FUNC FNC2</b>	Switching characteristics	<b>HYNC HYNO</b>	HYNC: hysteresis/NC contact HYNO: hysteresis/NO contact (→ Fig. 16) Factory setting: <b>HYNO</b>
	<b>SP SP2</b>	Switch point value	<b>0.0</b>	<ul style="list-style-type: none"> <li>Enter value 5 to 100% in increments of 1%. Factory setting: <b>50%</b></li> </ul> <b>Or optionally for SP2:</b> <ul style="list-style-type: none"> <li>Enter value -15 to 85 °C (-5 to 185 °F) in increments of 1 °C (1 °F) if the switching mode MODE is set to temperature TEMP. Factory setting: <b>55 °C</b></li> </ul>
	<b>SPL SP2L</b>	Switch point 'Learn'	<b>RUN WAIT</b>	RUN, WAIT: take the current flow rate as the switch point SP or SP2. See 'Navigating the Learn function' (→ Fig. 12).
	<b>RSP RSP2</b>	Switchback point value	<b>0.0</b>	<ul style="list-style-type: none"> <li>Enter value 0 to 95% in increments of 1%. Factory setting: <b>40%</b></li> </ul>  The value has to be at least 5% smaller than the switch point (SP or SP2).  <b>Or optionally for RSP2:</b> <ul style="list-style-type: none"> <li>Enter value -20 to 80 °C (-4 to 176 °F) in increments of 1 °C (1 °F) if the switching mode MODE is set to temperature TEMP. Factory setting: <b>50 °C</b></li> </ul>  Value has to be at least 5 °C (9 °F) smaller than switch point 2 (SP2).
	<b>TSP TSP2</b>	Switch point delay	<b>0.0</b>	Can be set anywhere between 0 and 99 s in increments of 1 second. Factory setting: <b>0 s</b>
	<b>TRSP TRSP2</b>	Switchback point delay	<b>0.0</b>	Can be set anywhere between 0 and 99 s in increments of 1 second. Factory setting: <b>0 s</b>

## 5.1.9 Settings for output - 1 x analog output (4 to 20 mA) and 1 x switch output

Function group	Function		Settings	Description
<b>4-20</b> Output 1	<b>MODE</b>	Measurement mode for analog output	<b>FLOW TEMP</b>	Output FLOW: flow rate or TEMP: temperature  For TEMP setting (temperature), the measuring range is specified at -20 °C to +85 °C (-4 °F to 185 °F). Factory setting: <b>FLOW</b>
	<b>FCUR</b>	Error current	<b>MIN MAX HOLD</b>	Current value in event of error: MIN = ≤ 3.5 mA MAX = ≥ 21.7 mA HOLD = last current value Factory setting: <b>MAX</b>
<b>OUT</b> Output 2	<b>MODE</b>	Switching mode	<b>FLOW TEMP</b>	Output switching mode FLOW: flow rate or TEMP: temperature Factory setting: <b>temperature (TEMP)</b>
	<b>UNIT</b>	Technical unit	<b>×C ×F</b>	Temperature unit selection °C or °F  Function only visible if the switching mode MODE is set to temperature TEMP in the 2nd output. Factory setting: °C
	<b>FUNC</b>	Switching characteristics	<b>HYNC HYNO</b>	HYNC: hysteresis/NC contact HYNO: hysteresis/NO contact (→ Fig. 16) Factory setting: <b>HYNO</b>
	<b>SP</b>	Switch point value	<b>0.0</b>	<ul style="list-style-type: none"> <li>▪ Enter value 5 to 100% in increments of 1%.                Factory setting: <b>50%</b></li> </ul> <b>or:</b> <ul style="list-style-type: none"> <li>▪ Enter value -15 to 85 °C (-5 to 185 °F) in increments of 1 °C (1 °F) if the switching mode MODE is set to temperature TEMP.                Factory setting: <b>55 °C</b></li> </ul>
	<b>SPL</b>	Switch point 'Learn'	<b>RUN WAIT</b>	RUN, WAIT: take the current flow rate as the switch point SP. See 'Navigating the Learn function' (→ Page 15).

Function group	Function		Settings	Description
<b>OUT</b> continued	<b>RSP</b>	Switchback point value	<b>0.0</b>	<ul style="list-style-type: none"> <li>▪ Enter value 0 to 95% in increments of 1%. Factory setting: <b>40%</b></li> <li>                      The value has to be at least 5% smaller than the switch point SP.                 </li> </ul> <p>or:</p> <ul style="list-style-type: none"> <li>▪ Enter value -20 to 80 °C (-4 to 176 °F) in increments of 1 °C (1 °F) if the switching mode MODE is set to temperature TEMP. Factory setting: <b>50 °C</b></li> <li>                      Value has to be at least 5 °C (9 °F) smaller than switch point SP2.                 </li> </ul>
	<b>TSP</b>	Switch point delay	<b>0.0</b>	Can be set anywhere between 0 and 99 s in increments of 1 second. Factory setting: <b>0 s</b>
	<b>TRSP</b>	Switchback point delay	<b>0.0</b>	Can be set anywhere between 0 and 99 s in increments of 1 second. Factory setting: <b>0 s</b>

### 5.1.10 Setting for service functions

Function group	Function		Settings	Description
<b>SERV</b> Service functions	<b>LOCK</b>	Locking code	<b>0</b>	Enter the device locking code.
	<b>CODE</b>	Change locking code	<b>0</b>	User-defined code 1 to 9999; 0 = no locking; Only visible if the locking code is valid.
	<b>PRES</b>	Reset	<b>NO YES</b>	Reset all entries to factory settings.
	<b>REV' C</b>	Static revision counter	<b>0</b>	Configuration counter, incremented each time the configuration is changed.
	<b>STAT</b>	Device status		
	<b>LST'D</b>	Last error	<b>0</b>	Display of last error to occur.
Switch output version	<b>SIM SIM2</b>	Simulation for 2 x switch output	<b>OFF OPEN CLOS</b>	OFF: no simulation OPEN: switch output open CLOS: switch output closed
Analog output version (4 to 20 mA)	<b>SIM  SIMA</b>	Simulation for 1 x analog output (SIMA) and 1 x switch output (SIM)	<b>OFF OPEN CLOS</b>  <b>3.5 4 8 ...</b>	OFF: no simulation OPEN: switch output open CLOS: switch output closed  3.5, 4, 8...: Simulation values for analog output in mA (3.5/4.0/8.0/12.0/16.0/20.0/21.7)



## 5.2 Operation with PC and configuration software

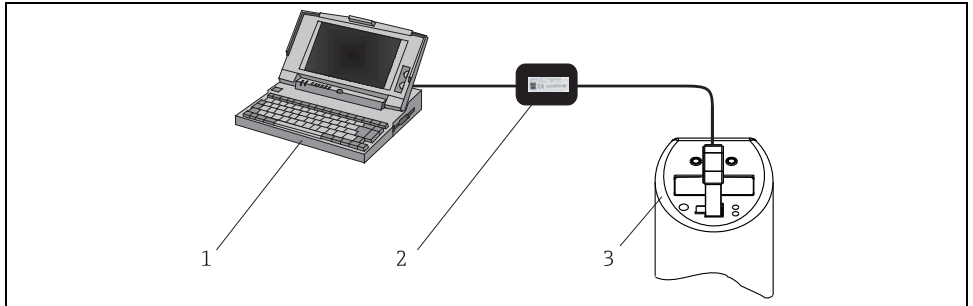

Fig. 17: Operation, visualization and maintenance with PC and configuration software.

- Item 1: PC with ReadWin® 2000 or Fieldcare configuration software
- Item 2: Configuration kit TXU10-AA or FXA291 with USB port
- Item 3: Flow switch

### 5.2.1 Additional operating options

In addition to the operating options listed in the previous "Onsite operation" section, the ReadWin® 2000 or FieldCare configuration software provides further information on the Flowphant® T:

Function group	Function (display)	Description
SERV (Service)	Switching processes 1 Switching processes 2, optional	Number of changes in switching status for switch output 1; optionally switch output 2
INFO (device information)	TAG 1 TAG 2	Tagging, 18-digit
	Order code	Order code
	Device serial number	-
	Sensor serial number	-
	Electronics serial number	-
	Device revision	Display of entire revision
	Hardware revision	-
	Software revision	-

### 5.2.2 Hints for the configuration with ReadWin® 2000

Comprehensive information on the ReadWin® 2000 configuration software may be found in the Operating Instructions BA137R/09/en.

### 5.2.3 Hints for the configuration with FieldCare

FieldCare is an universal configuration software based on FDT/DTM technology.

#### **NOTICE**

To configure the Flowphant® T DTT31/35 with FieldCare the “PCP (ReadWin) Communication DTM” and the Flowphant Device-DTM are required.

The device supports only offline configuration and up-/download of parameters. The online configuration is not supported.

Detailed information concerning FieldCare may be found in the operation manual (BA027S/c4) or see: [www.endress.com](http://www.endress.com).

## 6 Maintenance

Any buildup on the sensor can have a negative effect on the accuracy. For this reason, check the sensor for buildup at regular intervals.

#### **⚠ CAUTION**

Make sure the process is unpressurized before you remove the device! Do not twist the device out of the process connection thread at the housing. Always use a suitable open-ended wrench for disassembly work (see also → Fig. 5) (→ Chap. 3.3.1).

## 7 Accessories

All dimensions in the drawings are given in mm (in).

### 7.1 Welding bosses and coupling

#### 7.1.1 Welding boss with sealing taper

Collar welding boss moveable with sealing taper and pressure screw;  
 material of parts in contact with the process:  
 316L, PEEK,  
 Max. process pressure 10 bar (145 psi)  
 Order number: 51004751

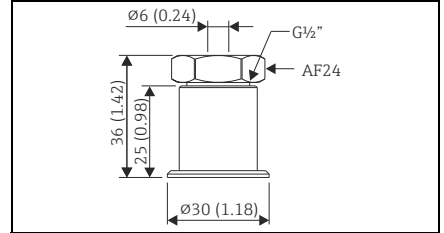

A0020709-EN

#### 7.1.2 Collar welding boss

Material of parts in contact with process:  
 316L  
 Order no. 51004752

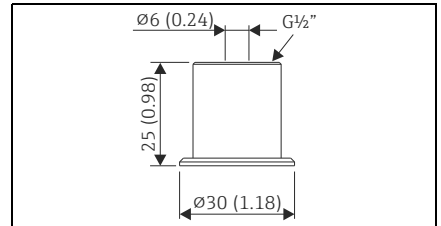

A0020710

#### 7.1.3 Welding boss with sealing taper (metal - metal)

Welding boss  
 Seal, metal-metal,  
 Material of parts in contact with process:  
 316L  
 Max. process pressure 16 bar (232 psi)  
 Order no. 60021387

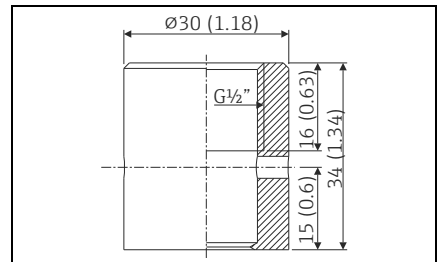

A0006621

### 7.1.4 Coupling

Moveable coupling, G $\frac{1}{2}$ " process connection, material coupling and parts in contact with process: 316L  
 Order no. 51004753

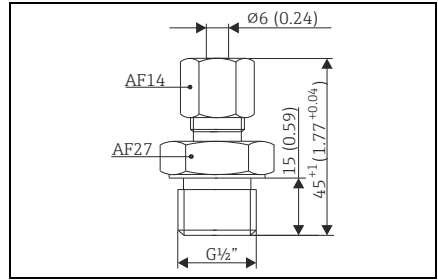

A0020174-EN

## 7.2 Electrical connection

### 7.2.1 Coupling; connecting cable

Coupling M12x1; straight  
 Connection to M12x1 housing connector  
 Order number: 52006263

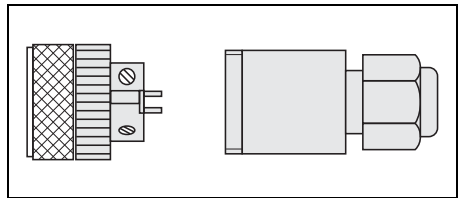

F01-PMP13xxx-00-xx-00-xx-003

Coupling M12x1 for own assembly of the connecting cable; elbowed  
 Connection to M12x1 housing connector  
 Degree of protection (connected): IP67, PG7  
 Order number: 51006327

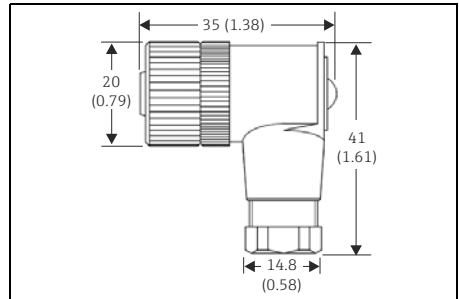

A0020722

PVC cable, 4 x 0.34 mm<sup>2</sup> (22 AWG) with M12x1 coupling (assembled), elbowed, screw plug, length 5 m (16.4 ft), degree of protection: IP67  
 order number: 51005148

Core colors:

- 1 = BN brown
- 2 = WH white
- 3 = BU blue
- 4 = BK black

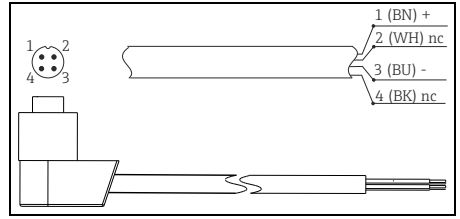

A0020723

PVC cable, 4 x 0.34 mm<sup>2</sup> (22 AWG) with M12x1 coupling, with LED, elbowed, 316L screw plug, length 5 m (16.4 ft), especially for hygiene applications, degree of protection (connected): IP69K  
 order number: 52018763

Display:

- gn: device operational
- ye1: switch status 1
- ye2: switch status 2



Not suitable for 4 to 20 mA analog output!

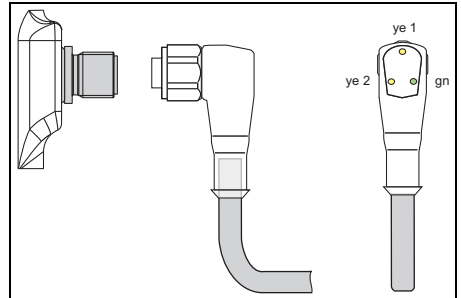

T09-TTR31xxx-00-00-xx-xx-001

### 7.3 Configuration kit

- Configuration kit for PC-programmable transmitters - ReadWin<sup>®</sup> 2000 setup program and interface cable (4 pin plug) for PCs with USB port, Order code: **TXU10-AA**
- Configuration kit "Commubox FXA291" with interface cable for PCs with USB port. Intrinsically safe CDI interface (Endress+Hauser Common Data Interface) for transmitters with 4-pole post connector. Suitable device configuration tool is e.g. FieldCare. Order code: **FXA291**

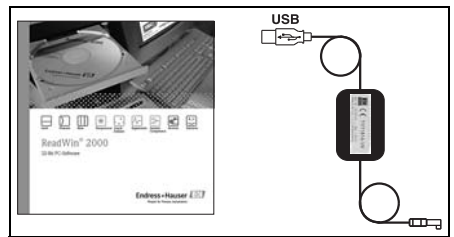

A0008067

## 7.4 Configuration software

The ReadWin® 2000 and FieldCare 'Device Setup' configuration programs can be downloaded free of charge from the Internet at the following address:

- [www.endress.com/readwin](http://www.endress.com/readwin)
- [www.products.endress.com/fieldcare](http://www.products.endress.com/fieldcare)

FieldCare 'Device Setup' can also be ordered from an Endress+Hauser sales office.

## 8 Troubleshooting

### 8.1 Error messages and warning messages

If an error occurs in the device, the color of the status LED changes from green to red and the illumination of the digital display changes from white to red. A status LED flashing red and green signals a warning. The display shows:

- E-code for errors  
In the event of an error message, the measured value is uncertain.
- W-code for warnings  
In the event of a warning, the measured value is reliable.

Code	Explanation	Remedy
E011	Device configuration faulty	Reset device (→ Chap. 5.1.10)
E012	Error in measurement or medium temperature outside measurable range	Check medium temperature, return device to Endress+Hauser where necessary
E013	Sensor heating defective	Return device to Endress+Hauser
E019	Power supply outside specification	Check operating voltage
E015	Memory error	Return device to Endress+Hauser
E020		
E021		
E022	Power is only supplied to the device via the communication interface (measurement is deactivated)	Check operating voltage
E042	Output current can no longer be generated (only for 4 to 20 mA output, e.g. load at analog output too high or open analog output)	Check load; switch off analog output

Code	Explanation	Remedy
W107	Simulation active	
W200	Fluid temperature outside specification (> 85 °C)	Check fluid temperature and, where necessary, adapt it to the specification
W202	Measured flow rate outside the range between set Low and High Flow (< -10% or > 110%)	Set High and Low Flow again, reset device to factory setting where necessary (PRES function)
W209	Device starts	
W210	Configuration changed (warning code displayed for approx. 15 s)	
W240	Flow velocity too high (> 3 m/s in water), the device is operated outside its specified measuring range. The measurement is uncertain.	Reduce flow velocity of the medium
W250	Number of max. switch cycles exceeded	
W260	Values for High Flow (HIF) and Low Flow (LOWF) too close	Set High and Low Flow again (greater distance apart), reset device to factory setting where necessary (PRES function)
W270	Short-circuit and overload at output 1	Check output wiring
W280	Short-circuit and overload at output 2	Check output wiring
W432	Values for High Flow (HIF) or Low Flow (LOWF) could not be determined with certainty (→ Page 15). The device can be operated however.	Set High and Low Flow again (keep flow velocity constant!)

## 8.2 Repair

A repair is not planned.

## 8.3 Disposal

Please pay particular attention to the local disposal regulations of your country. When disposing, ensure that the materials of the device components are separated and processed accordingly.



## 8.4 Change status (release)

The release number on the nameplate and in the Operating Instructions indicates the change status of the device: XX.YY.ZZ (example 01.02.01).

XX	Change in the main version. Compatibility no longer provided. Device and Operating Instructions change.
YY	Change in functionality and operation. Compatibility provided. Operating Instructions change.
ZZ	Troubleshooting and internal modifications. Operating Instructions do not change.

## 8.5 Software history

Date	Software version	Software modifications	Documentation
02.2006	01.00.00	Original firmware	BA218r/09/en/02.06 (71022232)
12.2006	01.00.03	Analog output version (4 to 20 mA) available	BA235r/09/en/12.06 (71036991)
12.2006	01.00.03	-	BA235r/09/en/10.07 (71036991)
11.2008	01.00.04	Calibration function: Variable configuration for HIF (70 to 100%) and LOWF (0 to 20%); Warning message W200	BA235r/09/en/11.08 (71036991)
11.2008	01.00.04	-	BA235r/09/en/06.09 (71098494)
11.2008	01.00.04	-	BA235r/09/en/13.10 (71098494)
07.2013	01.00.08	-	BA00235R/09/EN/14.13 (71226085)
01.2014	01.00.08	-	BA00235R/09/EN/15.14 (71243850)

## 9 Technical data

### 9.1 Power supply

Supply voltage

- DC voltage version 18 to 30 V DC

Current consumption

- < 100 mA (open-circuit operation) at 24 V DC, max. 150 mA (open-circuit operation); with reverse polarity protection

Power supply failure

- Behavior in case of over voltage (> 30 V)

The device works continuously up to 34 V DC without any damage. No damage is caused to the device in case of a short-term over voltage up to 1 kV (as per EN 61000-4-5). If the supply voltage is exceeded, the properties specified are no longer guaranteed.

- Behavior in case of under voltage

If the supply voltage drops below the minimum value, the device switches off (status as if not supplied with power = switch open).

### 9.2 Output

Switching capacity

- Switch status ON:  $I_a \leq 250$  mA
- Switch status OFF:  $I_a \leq 1$  mA
- Switching cycles: > 10,000,000
- Voltage drop PNP:  $\leq 2$  V
- Overload protection

Automatic load testing of switching current; output is switched off in event of over current, the switching current is tested again every 0.5 s; max. capacitance load: 14  $\mu$ F for max. supply voltage (without resistive load); periodical protective disconnection in event of over current ( $f = 2$  Hz) and 'Warning' display.

Analog output: Signal on alarm as per NAMUR NE43

- Under ranging:

Linear drop to 3.8 mA

- Over ranging:

Linear rise to 20.5 mA

- Sensor breakage; sensor short-circuit:

$\leq 3.6$  mA or  $\geq 21.0$  mA (output 21.7 mA is guaranteed for setting  $\geq 21.0$  mA)

- Switch outputs: with safe status (switch open)

## 9.3 Operating conditions

- Orientation, → Chap. 3.4.1
- Top housing section can be rotated 310°

### 9.3.1 Operating conditions: Environment

- Ambient temperature range  
-40 to +85 °C (-40 to 185 °F)
- Storage temperature  
-40 to +85 °C (-40 to 185 °F)
- Climate class  
4K4H as per DIN EN 60721-3-4
- Degree of protection  
IP65 (optional IP66, depending on used connector)
- Shock resistance  
50 g as per DIN IEC 68-2-27 (11 ms)
- Vibration resistance  
20 g as per DIN IEC 68-2-6 (10-2000Hz)  
4 g as per guidelines of German Lloyd GL
- Electromagnetic compatibility  
Interference emission as per IEC 61326, class B equipment  
Interference immunity as per IEC 61326, Appendix A (industry) and  
NAMUR Recommendation NE21  
EMC influence: ≤ 0.5%

### 9.3.2 Operating conditions: Process

- Process flow limits  
Liquids: 0.03 to 3.0 m/s (0.1 to 9.84 ft/s)
- Process temperature limits  
-20 to 85 °C (-4 to 185 °F)  
The sensor can be exposed up to 130 °C (266 °F) without damage; monitoring switches off automatically at  $T \geq 85 \text{ °C}$  (185 °F) and starts again at  $T \leq 85 \text{ °C}$  (185 °F).
- Process pressure limits  
Maximum permitted process pressure  $p_{\max.} \leq 10 \text{ MPa} = 100 \text{ bar}$  (1450 psi)

#### **NOTICE**

The maximum process pressure for the conical metal-metal process connection (**MB** option) for the DTT35 is 1.6 MPa = 16 bar (232 psi)!



# Declaration of Contamination

## Erklärung zur Kontamination



People for Process Automation

RA No.

Because of legal regulations and for the safety of our employees and operating equipment, we need the "declaration of contamination", with your signature, before your order can be handled. Please make absolutely sure to include it with the shipping documents, or – even better – attach it to the outside of the packaging.  
*Aufgrund der gesetzlichen Vorschriften und zum Schutz unserer Mitarbeiter und Betriebseinrichtungen, benötigen wir die unterschriebene "Erklärung zur Kontamination", bevor Ihr Auftrag bearbeitet werden kann. Legen Sie diese unbedingt den Versandpapieren bei oder bringen Sie sie idealerweise außen an der Verpackung an.*

Type of instrument / sensor  Serial number   
 Geräte-/Sensortyp  Seriennummer

Used as SIL device in a Safety Instrumented System / Einsatz als SIL Gerät in Schutzeinrichtungen

Process data/ Prozessdaten Temperature / Temperatur  [°C] Pressure / Druck  [Pa]  
 Conductivity / Leitfähigkeit  [S] Viscosity / Viskosität  [mm<sup>2</sup>/s]

Medium and warnings  
 Warnhinweise zum Medium



	Medium / concentration Medium / Konzentration	Identification CAS No.	flammable entzündlich	toxic giftig	corrosive ätzend	harmful/ irritant/ gesundheitsschädlich/ reizend	other * sonstiges*	harmless unbedenklich
Process medium Medium im Prozess								
Medium for process cleaning Medium zur Prozessreinigung								
Returned part cleaned with Medium zur Endreinigung								

\* explosive; oxidising; dangerous for the environment; biological risk; radioactive  
 \* explosiv; brandfördernd; umweltgefährlich; biogefährlich; radioaktiv

Please tick should one of the above be applicable, include security sheet and, if necessary, special handling instructions.  
*Zutreffendes ankreuzen; trifft einer der Warnhinweise zu, Sicherheitsdatenblatt und ggf. spezielle Handhabungsvorschriften beilegen.*

Description of failure / Fehlerbeschreibung

Company data / Angaben zum Absender

Company / Firma <input type="text"/>	Contact person / Ansprechpartner <input type="text"/>
<input type="text"/>	Department / Abteilung <input type="text"/>
Address / Adresse <input type="text"/>	Phone number/ Telefon <input type="text"/>
<input type="text"/>	Fax / E-Mail <input type="text"/>
<input type="text"/>	Your order No. / Ihre Auftragsnr. <input type="text"/>

We hereby certify that the returned parts have been carefully cleaned. To the best of our knowledge they are free from any residues in dangerous quantities.  
*Hiermit bestätigen wir, dass die zurückgesandten Teile sorgfältig gereinigt wurden, und nach unserem Wissen frei von Rückständen in gefährbringender Menge sind.*

(place, date / Ort, Datum)

(Company stamp and legally binding signature)  
 (Firmenstempel und rechtsverbindliche Unterschrift)





[www.addresses.endress.com](http://www.addresses.endress.com)

---