



TIFFIN MOTORHOMES

SIDE ROADS

The Award-Winning Allegro Club Newsletter For Leisure & Living



Volume 4 Issue No.1
September 2007

3 Tiffin introduces
PowerGlide chassis
One-stop service
seen as huge draw

4-5 Gumbo, pork
tenderloin &
chocolate chip pie
Fall feasting
in your Tiffin rig

8-9 Testing the 35 TSB
Allegro Bay
Spacious living room,
handling draw praise



From the driver's seat by Jimmy Johnson

How would you like a 2008 Zephyr with all the options for \$50,000? Maybe a two-carat emerald-cut diamond in a platinum setting for \$200? Interested in a lovely Italian villa on the Mediterranean coast for \$25,000?

Sometimes, as those offers illustrate, deals are just too good to be true. And that's almost the case with Allegro Club rallies.

We try to offer half a dozen or so activity-filled rallies in beautiful locations coast-to-coast each year. Depending on campground fees, number of nights, catering, entertainment and other costs, our registration fees for two people in a Tiffin motorhome run from about \$200-600. We tried to stage a Disney World rally earlier this year, but the \$995 registration fee was a major factor in low registration numbers.

We ask each rally participant to complete a written feedback form, and the responses are 99% positive. We do, however, receive an occasional gripe: a full breakfast instead of doughnuts and coffee, more technicians performing more complimentary repairs, technicians from chassis manufacturers, fancier meals, bigger door prizes (like maybe that diamond ring). These complaints are, I repeat, the exceptions to the rule. We have never had more than two negative responses to the survey question: Would you attend another Allegro Club rally?

To those of you who have enjoyed our rallies, I promise more good times, good food, good entertainment, fellowship, camaraderie, networking and informational seminars at future rallies. And to those of you who wish for more alluring deals, like that almost-free Zephyr or Italian villa, the Allegro Club is good, but not that good.

If you pay a \$400 registration fee for a four-night rally with many meals, entertainment, campground fees and all our other amenities, the Allegro Club is likely paying double that to meet the rally costs. That's for each Tiffin coach. Above and beyond registration fee revenue, for a typical 120-coach rally, the Allegro Club must subsidize what to most participants are essentially hidden costs. Those hidden costs include Allegro Club staff and technicians' travel, parts and equipment for the complimentary technicians' repairs, bus transportation to off-site entertainment, goodie bags and door prizes, but the greatest of all: catering. At our Stone Mountain Georgia FMCA Pre-Rally, even a casual cookout of hamburgers and hotdogs ran up a \$2,000 bill for groceries and supplies. Camping builds the appetite.

Many chapters enjoy potluck dinners at their campouts, and that has been suggested to us as a way to reduce rally costs. While the concept sounds attractive, the liability issues do not. Just one case of salmonella from delicious deviled eggs or some chicken salad left a bit too long in the sun and the potential for lawsuits would reach throughout the Tiffin organization – in addition to jeopardizing the health and well-being of our members.

Dealers and suppliers often are generous contributors to our rallies, keeping costs and registration fees as low as possible. Many Allegro Club members take advantage of the latest models dealers display at our rallies. It's exciting to watch members shuttle their belongings from their "old" coaches to new ones at rallies.

The Allegro Club and Tiffin Motorhomes are not whining about rally costs. The opportunities to show new products and add to the RVing enjoyment of our customers make the rally subsidies worthwhile.

Just don't look for a diamond in the goodie bags.

President
Allegro Club

SIDE ROADS

Is published quarterly March, June, September and December
by the Allegro Club, Inc.

Presorted Standard U.S. Postage Paid
Permit # 159, Birmingham, AL

POSTMASTER: Send address changes to the Allegro Club, Inc.
P.O. Box 1429, Red Bay, AL 35582

NOTICE OF RESPONSIBILITY:

The Allegro Club, Inc., Red Bay, AL, has designed tours, caravans, and rallies for your pleasure and enjoyment and has attempted to select for you the best campgrounds, accommodations, restaurants, and transportation facilities for the prices charged. Allegro Club, Inc., Jimmy and Gail Johnson, and the Board of Directors do not own or operate any of the campgrounds, hotels, restaurants or transportation facilities and, furthermore, assume no responsibility for delays, losses, accidents, or for damage to persons or property caused by any person, firm, corporation, or other legal entity providing the following services: campgrounds, hotels, restaurants, transportation (including but not limited to transfers and sightseeing) or any other services incident to these tours, rallies, caravans or any activities of the Allegro Club, Inc. The right is reserved to substitute campgrounds, hotels, restaurants and alter the itinerary or reverse the places to be visited. The right is reserved to cancel the tour or caravan prior to departure. In the event of a tour or caravan cancellation, the Allegro Club, Inc., Jimmy and Gail Johnson, and the Board of Directors' liability is limited to a refund of money received.

The Allegro Club, Inc., Jimmy and Gail Johnson, and the Board of Directors reserve the right to make any changes, with or without notice, that might become necessary with the understanding that there is no extra charge. After a tour, caravan or rally begins, any unused portions of fees paid are not refundable. The Allegro Club, Inc., also reserves the right to terminate tour, caravan and rally services for any client at any time for good cause.

The mission of the Allegro Club is:

- 1) To promote friendship, fellowship and camaraderie among all owners of Tiffin-built motorhomes;
- 2) To provide pertinent information and assistance regarding Tiffin-built products, their maintenance and related safety topics;
- 3) To promote brand loyalty to Tiffin-built motorhomes among current owners;
- 4) To encourage ownership of Tiffin-built motorhomes among non-owners.

The Allegro Club reserves the right to edit submissions for space and clarity. Manuscripts, photographs, illustrations and other proposed content are welcomed and will be considered for publication. Reproduction in whole or part without written permission is prohibited. Content, including statements of fact and opinion, do not necessarily reflect the viewpoints of Tiffin Motorhomes, Inc. or the Allegro Club, Inc. Tiffin Motorhomes, Inc. and the Allegro Club, Inc. are not responsible for content. Privacy laws and policies prevent Side Roads from publishing memorials, illnesses and other personal information without written permission.

ON THE COVER

Pull up a camp chair to the 2008 Phaeton's optional galley slide-mounted 32" LCD TV to tailgate in style this fall... unless you want to join the folks inside watching "Law and Order" and "Two and a Half Men." The entertainment options get better and better, as you will read in this issue's accounting of new model features.

LETTERS TO THE EDITOR

Want to share an experience you had in your Tiffin Motorhome? Have a comment or suggestion about SideRoads, the Allegro Club newsletter? Write to:

Side Roads Editor, Allegro Club
P.O. Box 1429, Red Bay, AL 35582

Please include your name, address, email and phone number so we can contact you.

CONTACTS:

Tiffin Motorhomes Parts & Service:
(256) 356-0261

Allegro Club: (256) 356-8522
allegroclub@tiffinmotorhomes.com

Jimmy Johnson, Allegro Club president
Verbon Jones, Allegro Club office manager

Cynthia Skinner, Allegro Club membership coordinator

Janet Gober, Allegro Club administrative assistant

www.tiffinmotorhomes.com

Tiffin produces its own chassis

Tiffin Motorhomes is introducing its own chassis on some 2008 models, an initiative the Class A manufacturer sees as a major expansion of its industry-wide reputation for exceptional customer service.

“We take pride in giving our customers first-class service, engineering, materials, components and workmanship,” says General Manager Tim Tiffin. “We see one-stop service as a significant advantage for our customers. “We want to maximize their RVing time for enjoyment, not service. As we expand PowerGlide® production, more and more Tiffin owners will find the service experience a little easier at our factory service center.”

Tiffin has built and renovated production and warehousing facilities for the PowerGlide chassis at its plant that has been in operation since 1972 in Red Bay, AL. Gary Harris, manager of the PowerGlide assembly operation, says production doubled from one a week in July and is projected at one a day by September. Harris’ ultimate production goal is six chassis a day. Tiffin’s current overall production is 13 motorhomes a day.

The PowerGlide chassis will be offered initially on 2008 Allegro Bus diesel pushers with 425hp Cummins ISL 8.9-liter diesel engines that develop 1,200 lb.-ft. torque. Tiffin offers five floor plans in the luxury level 40- and 42-ft. Allegro Bus. Other key features of the PowerGlide chassis include an Allison electronic 3000 MH 6-speed automatic transmission with two overdrive

gears, keypad electronic shifter with digital readout, 35,600 lbs. GVWR, 45,600 lbs. GCWR, full air brakes with automatic slack adjusters and four-wheel ABS, Jacobs compression engine brake, direct-driven cooling system with a two-speed clutch, 55-degree wheel cut and raised-rail huck-bolted frame with low-profile engine mounting.

“Chassis manufacturers use many of the same components such as engines, transmissions and axles,” says Harris, who spent 10 ½ years at a chassis manufacturer dealership including 3 ½ years as general manager before joining Tiffin in late 2006.

“Our PowerGlide has a Vansco fully multiplexed electrical system with auto-reset fuses, which enables us to significantly reduce the number of wires that travel the length of the chassis,” Harris adds. “All information in the PowerGlide chassis travels on shared wire with components at either end to route the information from, say, the engine cooling system to a dashboard instrument. The fewer the wires, the fewer the problems over the life of the motorhome.”

Tiffin Motorhomes purchased a \$100,000 dynamometer for the PowerGlide chassis assembly. The dynamometer will enable Harris and his production staff to test engines at full load. “We should be able to identify and prevent any problems with each chassis before it advances beyond our operation. The dynamometer also provides us a platform for testing new products and designs.”

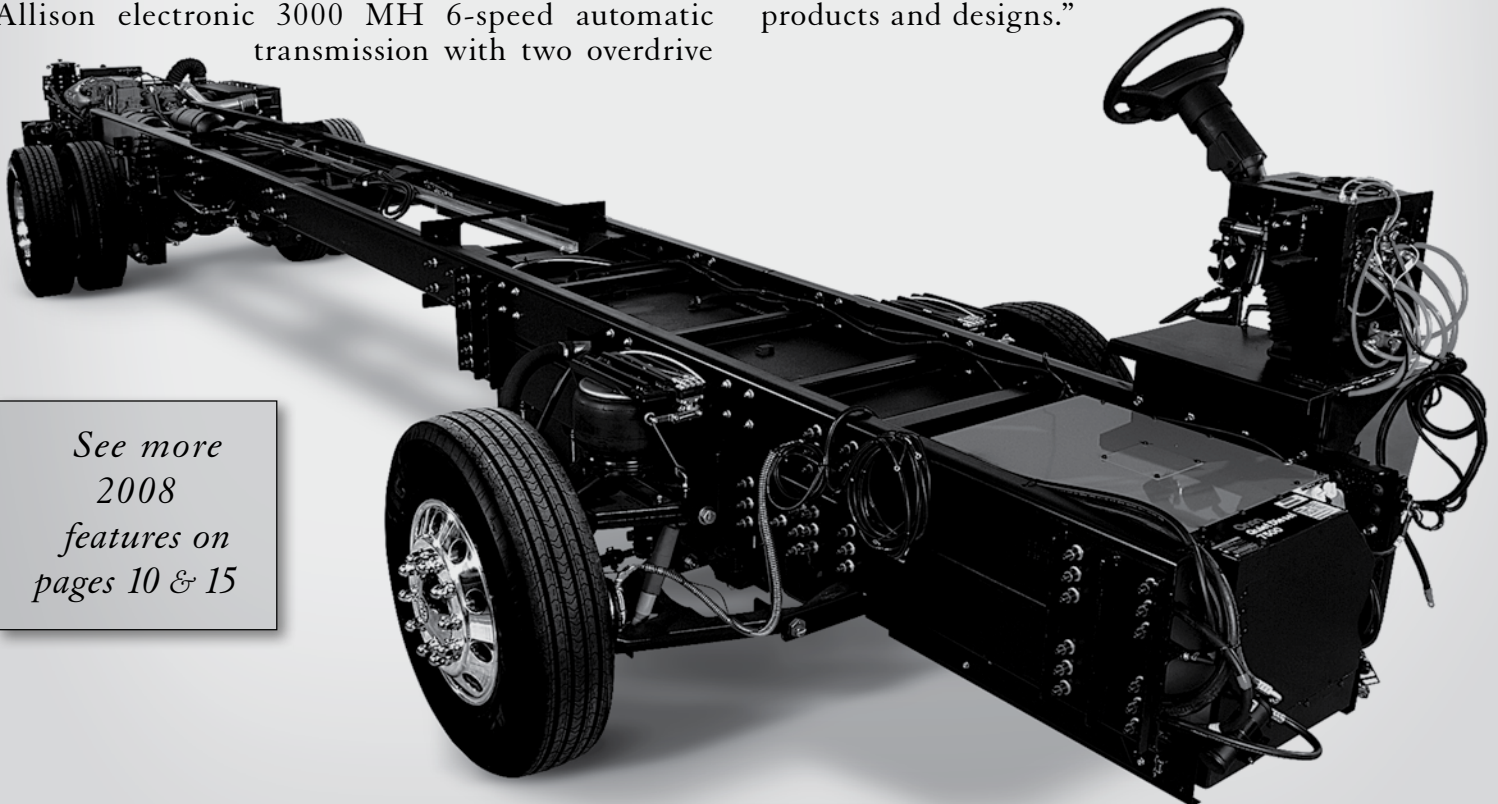

*See more
2008
features on
pages 10 & 15*

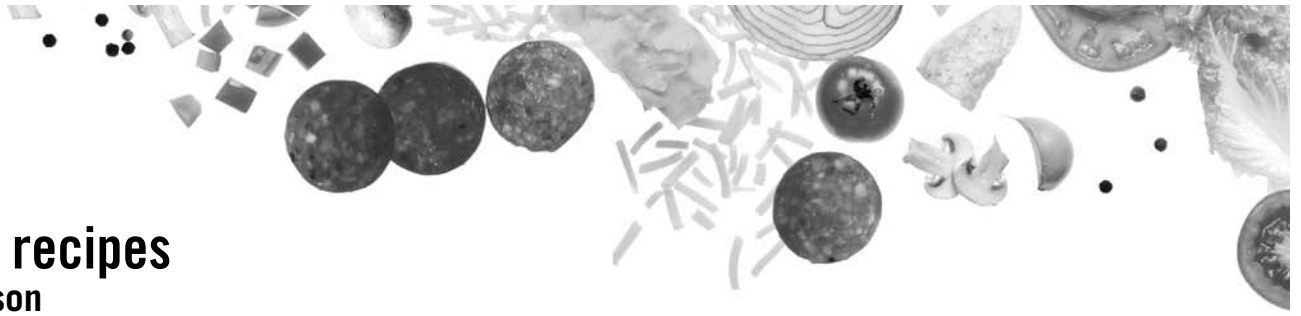

Roadside recipes

by Gail Johnson

Ah, Fall. Don't you just love it?

You may enjoy excursions through the countryside to view nature's brilliance. Or, perhaps you are among the throngs who avidly follow their favorite football teams and enjoy the festive atmosphere tailgating provides on these weekend events. Maybe you will attend your first Allegro Club rally this fall. We have two more good ones coming up in October and November. Or, it could be that you simply enjoy pulling into a quiet place beside a stream and doing a little fishing.

Whatever your pleasure might be in your Tiffin motorhome, I hope we can share some recipes with you in this issue that will suit the occasion and taste good too. ■

Lakeside Villas Gumbo

This recipe comes from the kitchen of Miriam Pepinsky. We enjoyed it one cool winter day in North Carolina in Pete and Miriam's home. Delicious.

Roux:

2/3 cup plain flour

2/3 cup canola oil

Ingredients:

1 large clove garlic, minced
1 teaspoon dried thyme
3/4 teaspoon cayenne
1/2 teaspoon salt
1 teaspoon black pepper

2 bay leaves
1 medium sweet onion, finely chopped
1 (16-oz.) can chicken broth
1/2 cup white wine
1/2 cup cold water

1 (16-oz.) can Italian-style diced tomatoes (do not drain)
1 link Andouille or smoked-sausage, quartered; may vary
1 lb. medium shrimp; shelled and deveined
1 teaspoon filé powder

Instructions:

Make the roux by cooking over low-to-medium heat until roux is the color of hazelnuts (about 30-40 minutes). Add garlic, thyme, cayenne, salt, pepper, bay leaves, onion, sausage; stir and sauté five minutes allowing flavors to meld. Add chicken broth, wine, water, and tomatoes. Bring to a boil, then turn down heat to simmer for about 90 minutes uncovered, stirring occasionally. Flavor intensifies the longer the gumbo simmers. Add shrimp 15 minutes before serving. Stir in filé powder. Serve with rice or baguette. Serves 4.

Taco Joe Dip

A dip that is easy to fix-and-forget, as you use a slow cooker in its preparation. Great for large gatherings

Ingredients:

1 (16 oz.) can kidney beans, rinsed and drained
1 (8 oz.) can tomato sauce
1 (16 oz.) can whole kernel corn, drained

1 (4 oz.) can chopped green chilies
1 (16 oz.) can black beans, rinsed and drained
1 envelope taco seasoning

1 (15 oz.) can stewed tomatoes
1/2 cup chopped onion
Tortilla chips

Instructions:

In a slow cooker, combine the first eight ingredients. Cover and cook on LOW for 5 to 7 hours. Serve with tortilla chips. Yields about 7 cups.

Note: To make soup, add a 29 oz. can of tomato sauce to the slow cooker. Serves 6-8.

Western Baked Beans

This dish is a great accompaniment to grilled food; it's easy and quick and can be cooked with or without the ground beef addition.

Ingredients:

2 (16 oz.) cans beans
1 tablespoon Worcestershire sauce

1/2 bell pepper, chopped
1 tablespoon white corn syrup

1/2 - 1 medium onion, chopped
1/4 cup catsup

1 cup brown sugar
1 lb. ground beef, cooked and drained

Instructions:

Mix all ingredients together; Bake at 350 degrees for 1 hour. Convection cooking may lessen cooking time to about 45 minutes.

Grilled Pork Tenderloin with Marinade

The aroma of this succulent cut of pork grilling will whet appetites for miles around. Great for tailgate parties.

Ingredients:

1 pork tenderloin, or two small ones
2 tablespoons minced garlic

1/4 cup olive oil
2 tablespoons lime juice

1/3 cup teriyaki sauce
salt and pepper as desired

Instructions:

Mix together ingredients listed and marinate pork in the mixture for 3 or 4 hours. (I use a heavy zip lock plastic bag). Preheat grill; cook meat on grill bottom rack for 2 or 3 minutes on each side to sear meat; then move meat to top rack (or away from direct heat) and cook until meat thermometer reaches 160 degrees.

Broccoli Salad

Easy to make ahead and serve as a side dish with soup or a grilled dinner. To save space in your refrigerator, mix the salad in a large bowl, then pour into gallon zip lock plastic bag for storage.

Ingredients:

3 stalks broccoli, cut into bite-size pieces
1 cup shredded Cheddar cheese

1 small red onion, chopped
1 cup mayonnaise

1 lb. bacon, fried crisp and crumbled
1 cup sugar

Instructions:

Combine first four ingredients; mix mayo and sugar and pour over broccoli mixture. Refrigerate at least 1 hour before serving.

Chocolate Chip Pie

This is truly one of the richest and most delicious pies I have ever eaten. It is so easy to make. Add nuts if you wish. This is a rich and mouth-watering dessert; it is even more delicious served with vanilla ice cream or whipped topping.

Ingredients:

1 thawed deep dish pie crust
1 stick melted butter or oleo
1 cup sugar

8 ounces semi-sweet chocolate chips
(if nuts are used, add only 6 oz. chips)
1/4 cup plain flour

2 eggs, beaten
1 cup chopped pecans, if desired

Instructions:

Mix eggs, sugar, flour, and oleo together; add chocolate chips and nuts. Mix well and pour into uncooked pie crust. Bake in a preheated 350 degree oven for about 45 minutes. If using convection, bake at 350 and start checking after about 35 minutes. The consistency will be similar to a chess pie; the center should be set and a crust will form over the top. If the center is soft and jiggles, it is not done. Inserting a toothpick or thin-blade knife should help you determine doneness. Also, if you find that the crust on the rim of the pie pan is browning too much, make a cuff from aluminum foil and place it carefully around the pie, covering only the rim of crust.

Cheers to all. May you enjoy a beautiful autumn season. We hope to see you on the road in your Tiffin motorhome.

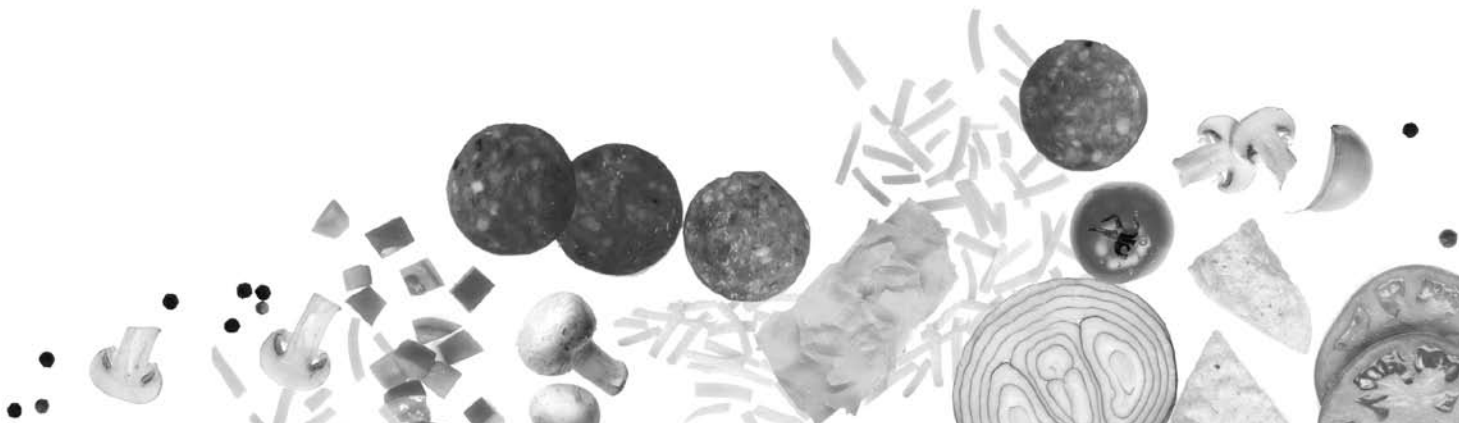

Yea though I drove through the Valley of Adventure

by Bob Poiry



Not long ago Carol and I decided to take a trip to Branson, MO. Three other couples from our chapter decided to go along so we now had four motorhomes traveling together. It proved to be a great adventure for all of us.

Carol and I had asked Ned and Trudy if they'd like to go for a ride with us in our Honda Civic. They agreed and off we headed for Arkansas.

We started to cross this overpass but I spotted some small buildings down below that looked like houses. I had to see them up close.

After driving a short distance I found a paved road off to the right. I'm doing about 35mph which is a reasonable speed for this paved road. But then as we crest the hill the pavement disappears and down we go on this steep decline of rocks as big as golf balls. Scary.

I know I can't stand on the brakes or the little car will go sideways. So I reach down and grab the emergency brake with my right hand, holding on to the steering wheel with my left hand for dear life.

Whew. The backseat screaming has begun to cease. Ned, in the right front seat, has gone silent. I try to convey a sense of security by speaking calmly, but I think my voice is squeaking. Still headed downhill, the road narrows and curves back and forth.

We finally get to what we think is the bottom of the valley we had seen from above. That overpass is now about 200 feet above us. We're all just begining to enjoy ourselves when we notice little things that give us the feeling we don't belong down here.

Like large rocks and boulders imbedded in the road.

If you're familiar with a Honda Civic you know they don't have much ground clearance anyway.

We start noticing old pickup trucks, some upside down or on their sides. Most of them have their hoods up. I tell Trudy to refrain from taking pictures from here on. Ned is now pale and hasn't spoken for at least an hour. I can hear his fingernails scratching the outside of the car door and his breathing is getting shallow.

We also begin noticing that every stationary object has bullet holes in it. There are bullet holes in signs, trees, cars, trucks, everything.

We're out of our zone. We come to this ragged little bridge with a weight limit sign that has obviously been stolen from another bridge. Coming toward us is a 42-ft. Phaeton as beautiful as they come.

The RVers just wave and continue on their merry way. A short distance beyond we come to a beautiful lakefront, probably the southern tip of Lake Taneycomo.

We're back to real homes and civilization. The road is heading uphill, turning into pavement. Ned is beginning to have a great time, talking and breathing normal. We survived a three hour trip through the valley.



The Quartzsite Happening in January 2008 gives new meaning to the term "dry camping." As in the Arizona desert.

If you find yourself in the Arizona desert at mile marker 98 along U.S. Hwy. 95, look for at least five rigs from the Allegro Golden Bears. Orland Dodson of that chapter reports that the Quartzsite Happening is "the largest RV show we've ever seen" with a large vendor tent. "You will be amazed by the amount of RVers that travel to this happening."

"We are pleased that La Mesa RV, one of the largest Tiffin dealers, is heavily involved in this event with a service center and restaurant on site," Club President Jimmy Johnson says. "Arizona in January sure beats ice and snow elsewhere." Johnson encourages members to consider the Quartzsite Happening in their travels.

Finding a campsite should be no problem. "There are acres of open land (desert) to set up camp." Dodson adds. "It is strictly dry camping but they have water and waste service available for a fee. The Quartzsite Happening is something you've never seen and worth a trip."

For more information contact Dodson at knododson@verizon.net or 209-823-5925. Or visit www.Quartzsitervshow.com

The Yankee Doodler *Cartoonist Bob Poiry*

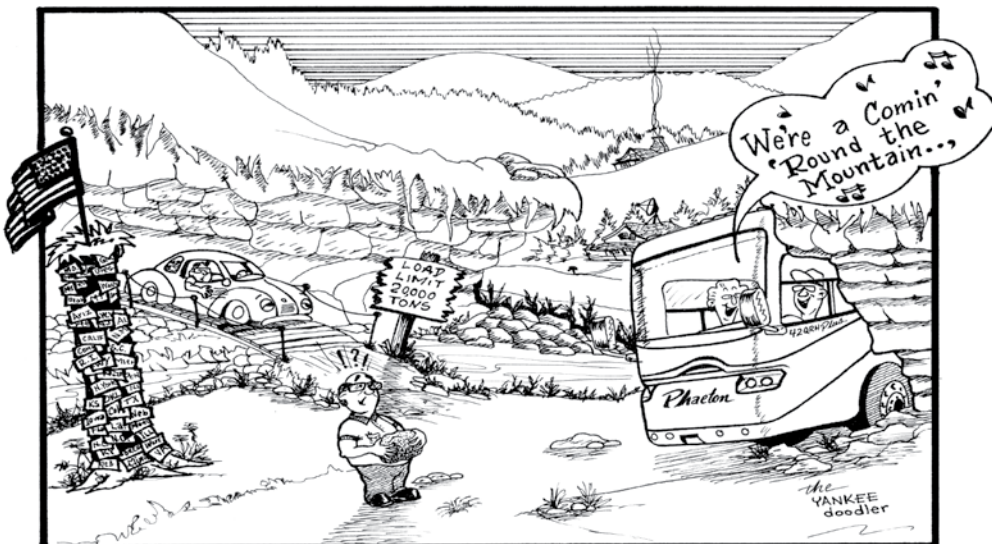

What the owners say: Testing the 2007 Allegro

OUR REVIEWERS



Bob and Donna Mills have been RVing for two years. Their Allegro Bay 35 TSB is their first Tiffin product, second motorhome.

Their permanent home is in East Tawas, MI and they are members of the Allegro Ramblers of Eastern Michigan. They lived in their front-engine diesel for

two months in Florida, recently attended their first chapter campout in Big Rapids, MI, and enjoy all aspects of RVing. The Mills offer this general comment about their selection: "We are well pleased with the purchase and after talking with so many different people and having gone to Red Bay, we feel confident that we picked the right company to deal with.

yuperbob@hotmail.com, 989-362-5734

TURNING RADIUS, ROAD HANDLING AND STABILITY

The turning radius and handling are much better than our (previous non-Tiffin) coach.

POWER/TORQUE

The torque and pickup also are much better. I feel that having the diesel in front also stopped the swaying that happens when trucks pass on the freeway.

LEARNING CURVE FOR MAINTENANCE, ELECTRONICS AND OTHER FEATURES

We know that there are things that have to be done in order to keep the RV in top shape, such as cleaning the paint, changing the oil, keeping the RV clean inside and out. Tire pressure is important, in fact I bought an air compressor just for that reason. We are learning everything we need to keep the unit in top shape. I am impressed with the flat screen TVs, the convection microwave and the washer/dryer. The surround sound is good. I also like the exhaust fans – all three of them.

NOISE LEVEL (BOTH PARKED AND MOVING)

The noise level parked and while driving was minimal, probably less than gasoline engines.

EFFICIENCY OF HEATING AND COOLING SYSTEMS

I like the idea of the heat pumps as they do save on propane gas.

SPACIOUSNESS OF LIVING ROOM

We don't feel cramped at all in the living room and do find it quite spacious, much better than our (previous coach).

ATTRACTIVENESS OF INTERIOR DECORATION

The layout of our coach is very homey and comfortable. I like all of the lighting. I would like to suggest that the inside light by the door should be the same type as the ones over the table and couch. They installed one that is the same as the cargo lights, which by the way, are very nice when you have to be in there at night.

WORKABILITY OF GALLEY

The kitchen has more than adequate cupboard space and countertop room. We have the double-door refrigerator with ice maker which is very nice.

COMFORT AND USABILITY OF BATHROOM

The bathroom isn't as congested either. In fact, we feel that we could live in the unit months at a time without feeling walls coming in on us.

LIVABILITY OF BEDROOM

The storage space is great. We like the clothes closets and the hamper, and the Sleep Number bed is a nice touch.

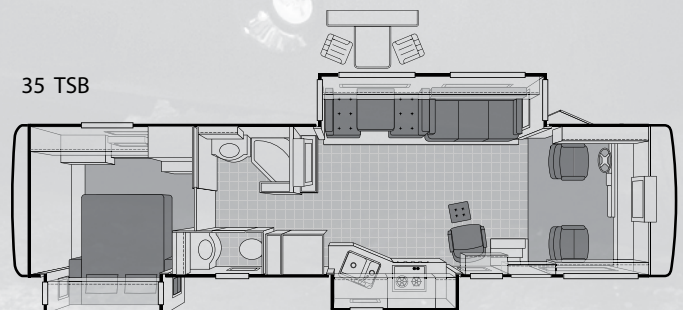

Bay 35 TSB

OUR REVIEWERS



Don and Carol Sussey have been married 45 years and have been fulltimers for the past five years. They spend their summer months in northern New

York and winter months “somewhere in the South.” The past two years they wintered in Pine Mountain, GA. Most of the time, just Don and Carol are in the coach, but grandkids join them once in a while. The Allegro Bay is their fourth motorhome (three were purchased new) and the first from Tiffin.

“We liked the Allegro Bay immediately,” the Susseys say. “Overall we are very pleased.”
dsussey@netscape.com, 518-569-3161

TURNING RADIUS, ROAD HANDLING AND STABILITY

The rig drives nearly as well as our previous diesel, but the basement space is rather limited.

POWER/TORQUE

A little sluggish on hills, towing 4000- lb. vehicle, but otherwise acceptable.

LEARNING CURVE FOR MAINTENANCE, ELECTRONICS AND OTHER FEATURES

No problem with learning curve. The auto levelers are really handy. The hardest challenge is setting up the VCR, but grandkids are a great help.

NOISE LEVEL (BOTH PARKED AND MOVING)

The noise level driving or sitting is very tolerable.

EFFICIENCY OF HEATING AND COOLING SYSTEMS

The furnace was more than adequate last February in central western Georgia, but the air does not keep up (runs continually) in the 85-degree heat.

SPACIOUSNESS OF LIVING ROOM

The living area is huge for the shorter length.

ATTRACTIVENESS OF INTERIOR DECORATION

The décor is very pleasing.

WORKABILITY OF GALLEY

Carol loves the galley area. The workmanship is superb for the price. The extra sink comes in handy, but extra storage would be more beneficial for our situation.

COMFORT AND USABILITY OF BATHROOM

The bathroom is very usable and nicely done.

LIVABILITY OF BEDROOM

The bedroom is comfortable, especially the Sleep Number bed, but deeper drawers would be welcome.



“Carol loves the galley area. The workmanship is superb for the price.”

Lone remote controls all entertainment in Tiffin models

In most Tiffin Motorhomes' 2008 models, the person holding the remote control has great power at his or her fingertips.

A lone remote controls all TVs, satellite and DVD in the Allegro Bay, Phaeton, Allegro Bus and Zephyrs currently arriving at Tiffin dealerships throughout the U.S. and Canada.

"At our house, I bet we have eight remote controls and I never remember which one works what," says Tiffin Sales Manager Jerry Williamson. "This electronic advancement makes viewing quick and easy."

Williamson adds that his home situation is very similar to motorhome viewing experiences. "About 98% of our customers

tell us they don't want to read manuals, they don't remember everything they hear during the new vehicle walk-through at the dealership, and they are frustrated. We are making sure our electronics are user-friendly, because that's the only way these electronics will be enjoyed. We all want things simpler, partly because we're not getting any younger and we don't always have a teenager around to figure out gizmos for us."

TVs, surround sound, DVD and satellite receivers interface through component cables. No manual switch boxes are required. Satellite receivers are ordered separately through satellite signal providers, often packaged with house subscriptions.

Tiffin offers HD-ready TV

Tiffin Motorhomes is introducing High-Definition (HD) ready TV in most of its 2008 models.

Owners of 2008 Allegro Bay, Phaeton, Allegro Bus and Zephyr just subscribe to a HD satellite service with the receiver that service provides to enjoy programming in HD.

"We also are wiring coaches for a second satellite receiver, so owners could watch different programs in HD at once," says Van Tiffin, research and design manager for the award-winning manufacturer that emphasizes customer service. "HD has quickly established itself as our current viewing standard at home, so on the road should not be different."

Tiffin's entry-level 2008 Allegro offers high-ticket features



full-body paint in models whose MSRP starts less than half that price.

But full body paint is far from the only upgrade in the 2008 Allegro.

Full tile flooring in the living area and galley will speed cleanup of tracked-in dirt. An optional free-standing dinette provides additional versatility and storage.

"The free-standing dinette changed the whole perception and usage of the living area, opening it up significantly," Williamson says.

Tiffin added to those features for the new Allegro: upgraded plumbing fixtures, full slideout ball-bearing galley drawers, an automatic satellite dish as well as a satellite dish tripod and an optional Air Coil[®] hide-a-bed sofa sleeper.

The Allegro is offered in six floor plans ranging from 28- to 35-ft., including four with optional front-engine diesel Freightliner[®] chassis.

"Our new Allegro represents a comfortable, classy motorhome in a price range that will appeal to many RVers," Williamson says.

Optional full-body paint, tiled living room and galley floor and a free-standing dinette are just a few of the improvements that make Tiffin Motorhomes' moderately priced Allegro a beauty as well as a bargain.

In the first model year Tiffin is offering optional full-body paint on its entry-level Allegro line, Sales Manager Jerry Williamson predicts 90% of the Allegros sold will wear the Champagne, Silver Sand or Sunlit Sand full-body coats.

"This is a big splash for us," Williamson says.

Long the province of \$200,000-plus motorhomes, Tiffin is introducing

Tiffin Motorhomes honors its top dealers

Lazy Days RV Center in Seffner, FL, has been named Tiffin Motorhomes' No. 1 dealer for 2007. The Top 10 Dealers were honored recently at the award-winning manufacturer's annual dealers meeting in Orlando, FL.

Lazy Days opened in 1976 in a mobile home on a leased 1.75-acre lot with two travel trailers in inventory and \$500 in capital. In 1996, Lazy Days moved into its 160-acre SuperCenter, which has 1,200 RVs on display, 700 employees, 273 service bays and a 300-site RV park.

The other Top 10 Tiffin Dealers for 2007 are La Mesa RV, with nine locations in California, Arizona, Florida and Georgia; Bankston Motor Homes Inc., Huntsville, AL; Marlin Ingram's RV Center Inc., Montgomery, AL; J.C.'s RVs Inc., Livermore, CA; Suncoast RV, Conyers and Byron, GA; Dickey-Stout Motor Ranch, Amarillo, TX; Horizon Lussier LTEE, Quebec, Canada; Sherman RV Center, Sherman, MS; and King's Campers Inc., Wausau, WI.

The Tiffin network of 78 dealers spans the U.S. and Canada.

Allegro Club Niagara Falls Rally

June 16 – June 18, 2008 (Check out June 19)
Four Mile Creek State Park / Youngstown, NY



This event is available to the first 120 eligible applicants.

Cost Includes: 3 nights camping fee, several meals, entertainment & activities. When on hand, Tiffin factory technicians will perform minor repairs at no cost. Colton RV will display the latest in Tiffin-built motorhomes for your viewing. Plenty of food, fun and fellowship.

Cost: Allegro Club member motorhome with two (2) people / \$295 • Allegro Club member motorhome with one (1) person / \$225 • Non-member motorhome with two (2) people / \$495 • Non-member motorhome with one (1) person / \$425 • Each additional guest / \$100

Total Cost: \$ _____

Number of people _____ Amount enclosed (*full payment required*) \$ _____

Name: _____

Second person's name: _____

Mailing Address: _____

City/State/Zip: _____

Telephone number: _____ Allegro Club #: _____ Chapter #: _____

Name of guest(s) in member's motorhome: _____

We wish to park with our chapter (listed above) or individual: _____

We will be in: Allegro Allegro Star Allegro Bay Allegro Bus Open Road Phaeton Zephyr

Motorhome length: _____ License plate #: _____ State: _____

Tow vehicle: Make: _____ License plate #: _____ State: _____

My chassis is: Ford Workhorse Chevrolet Oshkosh Spartan Freightliner John Deere

Other: _____

YES / NO This is our first Allegro Club rally.

YES / NO We wish to park in the handicapped section. (*Enclose Handicapped Certification copy with your registration.*)

YES / NO We will bring our pet(s).

Participants wishing to park together must send registration and rally fee in together!

Get your reservations in early. There will be only 120 spaces available.

No reservations will be taken after the deadline of May 2, 2008. The refund deadline is May 2, 2008.

Send check, money order or fill out complete credit card information below:

Visa Master Card Discover

Credit Card Number:

Expiration Date

_____ / _____ / _____ / _____	_____ / _____
1 2 3 4 / 5 6 7 8 / 9 10 11 12 / 13 14 15 16	Month / Year

Signature: _____

Call (256) 356-8522 to register by phone or fax your registration form to (256) 356-9746.

You can mail your reservation form with check payable to: **Allegro Club, P.O. Box 1429, Red Bay, AL 35582-1429**

Attention: *Early arrivals and late departures should be handled on your own by calling Four Mile Creek State Park at 800/456-2267.*

No partial or total refunds will be given after the refund deadline. Upon cancellation a \$20 handling fee will be charged. Travel insurance is an option available through Farm & City Insurance (1-800-331-1520). Payment must accompany each rally registration.

Important: *The Allegro Club has planned this event based upon claim assumptions, including a minimum number of participants. On occasion, circumstances arise which make the event impractical. Accordingly, the Allegro Club reserves the right to cancel the event for any reason, at any time and without obligation beyond the refund of any prepaid fees for the cancelled event.*

By registering for this event, you acknowledge and agree to the following statements: "I understand that neither the Allegro Club, Tiffin Motorhomes, Inc., nor any campground, restaurant, bus service or supplier assume any responsibility directly or indirectly, for the use or operation of a car or recreational vehicle going to or from or during the rally; or for injuries before, during or after the rally; or damage to property of any kind before, during or after the event; and I also grant permission for the use of photographs, videotape, written or verbal testimonials and other media from the rally that depict registrants and their guests for promotional purposes by Tiffin Motorhomes Inc. and the Allegro Club."

CUT HERE





Chapter Chatter: Next time you pass this way

Campgrounds

The **Sun Coast Allegros** of Tampa report that **Winter Quarters Encore Park** in Bradenton, FL, is a very nice park with a large lake, laundry, showers, patios, 50-amp connections, a recreation hall, kitchen, two pools, nice and accommodating staff and a modest \$18 per night rate (jumps to \$60 per night for short-term campers from January through March). The park does not have cable TV (but all 2008 Tiffin models have satellite dishes).

Secure, sparkling clean, nice sites and clean private individual shower/bathrooms are descriptors used by the **Lucky 7 Allegros** of Las Vegas in reference to **Oasis RV Resort** on the south side of Las Vegas, but the good report gets even better. The campground has a convenience store, café for breakfast and lunch, dog areas, an adjacent dog park, a very nice meeting room, a free shuttle to dining, gaming and scheduled shows at South Point resort, a full-service spa and a trolley (for a fee) to the Las Vegas Strip. A word of caution: **Oasis RV Resort** is often heavily booked in snowbird season (January through April) and rodeo season (early December).



The **Niagara Frontier Allegros** recommend **Southwoods RV Resort** in Byron, NY. The chapter says the campground is family-oriented with young owners, has very clean restrooms, well maintained landscaping,

plus consumer-oriented facility upgrades in the works.

Plush is not a word we hear often describing



campgrounds, but that's what **Hidden Ridge RV Community** has going in Shelbyville, MI, according to the **Michigan Allegro Pathmakers**. Additional feedback: new, very accommodating, fresh and clean, overlooking ponds with a swan family. The **Mecosa Pines Campground** in Morley, MI, was sparkling as usual this June, the chapter also reports. This campground features a hay ride for the youngsters, circling the camp sites for waves and smiles.

Looking for a campground for a smaller gathering? The **Sun Coast Allegros** recommend **Indian Forest Campground** near Ocala, FL. The meeting hall is small – just right for about 18 people. The campground has wi-fi and cable, 50-amp pull-through sites, a quiet wooded environment and moderate prices for the area.

The **First Coast Allegros** of northeast Florida and southeast Georgia have nice things to say about **Grand Lakes RV and Golf Resort** in Orange Lake near Ocala, FL. The campground is in the middle of horse country and has a large swimming pool, very nice clubhouse with two kitchens and a rock fireplace, beautiful golf course, marina and store for freshwater fishing, double-size

RV lots, immaculate grounds with security gate, complimentary wi-fi and cable, 216 pull-through sites and friendly/helpful managers. The campground is often full in winter months, consequently does not take club reservations then.

Restaurants

We wouldn't routinely mention an American Legion post in our restaurant reviews, not from a lack of patriotism, just because the chow ain't all that hot. John Sicklesteel, secretary of the **Michigan Allegro Pathmakers**, changed that bias with beautifully phrased observations in his chapter report. At the Morley, MI, **American Legion Post**, the **Michigan Allegro Pathmakers** enjoyed the Friday night all-you-can-eat fish fry, then returned Sunday for breakfast. That visit, the chapter members sat in the Gold Star Mothers recognition corner. Writes Sicklesteel, they "thought about their sacrifices as we had our delicious food. It is a darn shame that radical leaders have to test our resolve of freedom so often and break the hearts of so many families."

The **North Texas Allegros** found a new eatery they like in "downtown" Elm Mott, TX, if a town with 190 residents has a downtown. It's the **Wild West Saloon and Steak House**. The menu is varied, including some Czech items. Service is excellent and the home-made meringue pies (chocolate, lemon and coconut during the chapter's visit) are out of this world.

Try **Roaring 20s Pizza and Pipes** in Bradenton, FL on the advice of the **Sun Coast Allegros** of Tampa. The pipes are for sound, not water or tobacco. The large hall with casual picnic table-type seating has a

Chapter chatter

(Continued from Page 12)

huge pipe organ that entertains diners nightly. The organ music pretty much rules out table conversations, though. Prices are reasonable, starting at \$6 and the menu includes pizza, calzones, salads and other casual fare.

The **Lucky 7 Allegros** of Las Vegas know that their city offers dining for every budget and taste, and they recommend the **South Coast**. The \$12.95 buffet includes salads, soup, seafood, Asian, American and Italian fare, barbecue and many desserts.

The **Sun Coast Allegros** have two recommendations in the St. Augustine, FL, area. The first is **Osteens**, which has moderate prices, great service, great seafood and meats. The second is **Columbia Restaurant** in Old St. Augustine with a dining balcony above the

shopping crowd, great ambiance and service plus a varied menu.

If you're looking for good country cooking in Elba, NY, the **Niagara Frontier Allegros** will send you to **Paulina's Restaurant**. It's very friendly with tasty breakfast, lunch and dinner menus.

Insults are not on the menu at the **Bib Restaurant** on Gun Lake in Michigan, but you can expect to find them, report the **Michigan Allegro Pathmakers**. The restaurant is known for entertaining its customers with insults, gags and great food. Bruce Burrows, a chapter member, got himself in trouble as soon as he entered the eatery by telling the server that the rumor that she had "frog legs" was an exaggeration. Her legs didn't look



that bad at all. He was rewarded with a strip of duct tape, securing him to his high chair. Perhaps the tape should have been a bit higher and earlier. At **Sandy's** restaurant nearby, the chapter says you will find a community gathering place with an extensive menu and plenty of outstanding food, but no insults.

New Allegro Club Chapters

Chapter #170 Erie Shores Allegros

Area: Cleveland Ohio
Meeting Weekend: 4th
President: Doc Bokanyi
Email: jlr@windstream.net
Ph: 440/458-8866

Chapter #171 Niagara Frontier Allegros

Area: Western NY
Meeting Weekend: 2nd
President: Doug Dailey
Email: myredjack@adelphia.net
Ph: 716/694-5615

Chapter #172 Green Mountain Allegros

Area: Rutland, VT
Meeting Weekend: 2nd
President: Cliff Brody
Email: brodycs@earthlink.net
Ph: 305/926-8549

Chapter #173 Nutmeg Allegros

Area: Connecticut
Meeting Weekend: 3rd
President: Lee Littrell
Email: lee_littrell@msm.com
Ph: 203/377-3805

Chapter #174 Jersey Allegros

Area: New Jersey
Meeting Weekend: 3rd
President: Richard Zyglar
Email: cmzyglar@aol.com
Ph: 609/448-4351

Chapter #175 The Virginia Allegro Lovers

Area: Virginia
Meeting Weekend: 2nd
President: Dave Stephenson
Email: drsfalcon@earthlink.net
Ph: 540/547-2374

Chapter #176 Tar Heel Allegros

Area: Eastern North Carolina
Meeting Weekend:
President: Sylvia Thompson
Email: sthompson893@ec.rr.com
Ph: 910/872-5068

Chapter #177 Piedmont Allegros

Area: Western North Carolina
Meeting Weekend: 2nd
President: Jim Queen
Email: stj_jmq@msn.com
Ph: 704/753-4112

Destination attractions

A **Prime Outlet Mall**, the **Gamble Plantation Historic State Park**, **Red Barn Flea Market**, **Sarasota Jungle Gardens**, museums, shopping and restaurants. If that doesn't touch all the campout location bases, what does? The **Sun Coast Allegros** recommend Bradenton, FL, about 45 minutes south of Tampa. The chapter stayed at **Winter Quarters Encore Park**.

Not to be outdone, the **Niagara Frontier Allegros** had **Niagara Falls**, **Batavia Downs and Casino** and the **Six Flags Darien Lake Amusement Park** at their fingertips while camping in Byron, NY.

If **Niagara Falls** is too much water for you, the **First Coast Allegros** want you to consider **Silver Springs** and **Ocala** horse ranches. They had a recent campout in **Orange Lake**, FL near **Ocala**.

Not to mention the list from the **Sun Coast Allegros** for the **St. Augustine** area: a boat tour of **St. Augustine Bay** with dolphins, fort and history narrative, a tram tour, historic homes, the **Flagler Hotel** (now a college and museum), beach, golf and more.

Tiffin's 30" door makes loading easy



Tiffin Motorhomes has taken the squeeze out of loading supplies in its two best-selling diesel pushers for 2008.

Skinned knuckles and precarious balancing acts to carry plastic tubs, luggage and grocery bags into the coach will be distant memories thanks to the widened step and well on the 2008 Tiffin Phaeton and Allegro Bus models. The '08 Phaeton and Allegro Bus also offer an additional five inches of legroom in the front passenger seat as the result of a reconfiguration of a living room slide.

"Just watching motorhome owners juggle belongings and supplies prompted us to widen this entryway," General Manager Tim Tiffin says. "We want to ease and shorten loading time so our owners can enjoy more time with friends at the campground, tailgating party or just on the road. This subtle modification will be very popular."

Tiffin upgrades blackout, solar shades

Day or night, darkness comes earlier and easier in Tiffin Motorhomes' 2008 diesel pushers.

Darkness and privacy come with the introduction of power blackout and solar shades by MCD RV Accessories in the cockpit and living area valances of Tiffin's top-of-the-line Zephyr. The new Allegro Bus features MCD single-piece power blackout windshield shade, manual driver and passenger blackout and solar shades, plus manual roller valance shades in all

windows except the galley and water closet. The 2008 Phaeton offers MCD shades in the cockpit, eliminating a track curtain.

"We are very impressed by the efficiency, durability and ease of operation these new accessories provide," says Van Tiffin, research and development manager for the 35-year-old motorhome manufacturer. "In the summertime, we're confident our customers will not be turning the air-conditioning thermostat down as often."

Midsection TV a hit

For decades, motorhome manufacturers located living area TVs above the driver and front passenger seats. Tiffin Motorhomes has found a new, popular spot that accommodates more viewers and has other advantages.

The midsection wall TV in the galley area of many Tiffin 2008 Allegro Bay, Phaeton and Zephyr floor plans has been an instant hit, according to Tiffin Sales Manager Jerry Williamson. The LCD TV is at seated eye-level to eliminate neck strain, reduce glare by being farther from large windows and enable viewers to watch their favorite programs from the swiveled front seats while the coach is parked.



P.O. BOX 1429
RED BAY, AL 35582
ADDRESS SERVICE
REQUESTED

PRESORTED STANDARD
U.S. POSTAGE PAID
PERMIT # 159
BIRMINGHAM, AL

There once was a poet from Shreveport

Ah, the literary talents of Allegro Club members seems boundless. In the June issue, we appealed to the poets of the road as we sought limericks that contained the name of a favorite campground game. Even though the limerick is believed to have its origins in Limerick, Ireland, our winner shares the surname of Scotland's national bard. **AUDREY BURNS** of **SHREVEPORT, LA**,

penned the following:

There once was a chapter in Maine
that loved to play Mexican Train.

As soon as they parked
they would play until dark.

And never would tire of the game.

Audrey will receive a prize package from the Allegro Club.

Our new quiz question: If you don't have a digital camera or a penchant for packing heavily, you're probably not going to fare well in our latest competition. This photographic contest seeks a photo of the most or most unusual external "stuff" towed or lashed onto a Tiffin Motorhome. We're looking for the quintessential can't-leave-home-without-it RVers (who may or may not follow the laws of physics in terms of GCWR).

Email your entry along with your name, address and phone number to allegroclub@tiffinmotorhomes.com. Please, only one entry per household. The Allegro Club is not responsible for lost entries. The judges will select the winner by November 1, 2007 and announce that winner in the December issue of Side Roads. The winner will receive a prize package from the Allegro Club.

2007-08 Allegro Club Rally Schedule **Begin Planning Now for 2008**

Allegro Club Fall Gulf Getaway

Gulf Breeze Resort

Gulf Shores, AL

October 1-5, 2007

(break camp October 6)

Allegro Club Florida Fall Festival

Rally Park

Seffner, FL

November 5-9, 2007

(break camp November 10)

Tiffin/Allegro Club Southwest Shootout

TBA

TBA, AZ

March 10-13, 2008 (break camp March 14)

Allegro Club TBA April or May 2008

Allegro Club Niagara Falls Fling

Four Mile Creek Campsite

Youngstown, NY

June 16-18, 2008

(break camp June 19)

Tiffin/Allegro Club Bay Bash

TBA

Bay Area, CA

June 24-26, 2008 (break camp June 27)

Allegro Club Branson or Bust

America's Best Campground

Branson, MO

September 22-26, 2008

(break camp September 27)

Allegro Club TBA October 2008

For additional information: allegroclub@tiffinmotorhomes.com or www.tiffinmotorhomes.com
Phone: 256-356-8522 • Fax: 256-356-9746 or write: Allegro Club P.O. Box 1429 • Red Bay, AL 35582-1429

Become an Allegro Club member or update your address info

If you're reading this newsletter, you're enjoying one of the benefits of Allegro Club membership. Other benefits include rallies, local chapters and discounts on insurance, campsite fees and car rental.

When you buy a new Tiffin Motorhome, the first year of Allegro Club membership is free. After that, a one-year

membership is \$25, a two-year membership is \$46, and a three-year membership is \$70, payable by check or credit card. For credit card payment, call (256) 356-8522. We want you to continue your membership and help us build our numbers by recruiting other owners of Tiffin Motorhomes.

Names: _____ Address: _____

Nickname for Allegro Club ID badge #1: _____

Nickname for Allegro Club ID badge #2: _____

Email: _____ City: _____ State: _____ Zip: _____

Home Phone: () - - Alternate Phone: () - -

Serial No. of Your Tiffin Motorhome: _____ Chassis type: _____ VIN _____

Are you interested in joining or starting a local chapter of the Allegro Club? _____

Name of dealer where motorhome was purchased: _____ Date of Purchase: _____