

# INSTRUCTIONS-PARTS LIST



**306-941**

Rev. S  
SUPERSEDES R

This manual contains **IMPORTANT WARNINGS** and **INSTRUCTIONS**  
READ AND RETAIN FOR REFERENCE

## ELECTRIC-HYDRAULIC AIRLESS PAINT SPRAYER **EH 333 HYDRA-SPRAY®**

*3000 psi (210 bar) MAXIMUM WORKING PRESSURE  
Provides 1 GPM at 1000 psi (70 bar)*

**Model 231-003, Series A**  
Basic Sprayer

**Model 226-333**  
Includes Sprayer Model 231-003, hose, gun,  
RAC IV™ DripLess™ Tip Guard and SwitchTip™.

**Model 226-336**  
Same as Sprayer Model 226-333 except includes suc-  
tion hose.

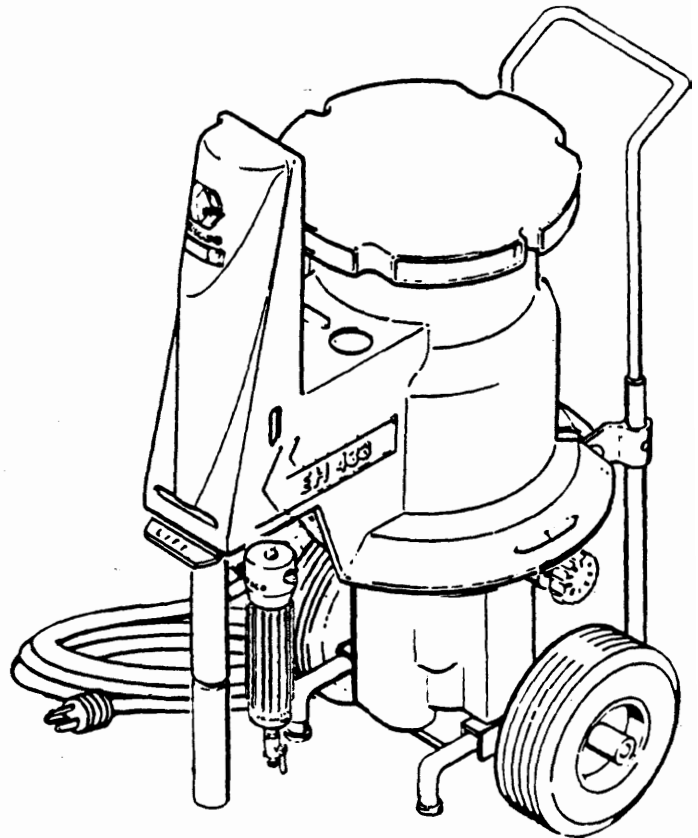

MODEL 226-333 SHOWN

### TABLE OF CONTENTS

Warnings.....	2, 3
Avertissement.....	4, 5
Advertencia.....	6, 7
Setup.....	8
Flushing Guidelines.....	9
Operation.....	10, 11
Maintenance.....	11, 12
Service.....	12-15
Troubleshooting Chart.....	12
Removing the Hydraulic Motor.....	13
Servicing Pump.....	13
Assembling Pump.....	13
Replacing the Electric Motor.....	14
Replacing the Hydraulic Pump.....	14
Electric Motor Wiring Diagram.....	15
Parts Drawing.....	16, 17
Parts List.....	18
How to Order Replacement Parts.....	19
Accessories.....	19
Technical Data.....	Back Cover
Warranty.....	Back Cover

### WARNING

#### Hazard of Using Fluids Containing Halogenated Hydrocarbons

Never use 1,1,1-trichloroethane, methylene chloride, other halogenated hydrocarbon solvents or fluids containing such solvents in this equipment. Such use could result in a serious chemical reaction, with the possibility of explosion, which could cause death, serious bodily injury and/or substantial property damage.

Consult your fluid suppliers to ensure that the fluids being used are compatible with aluminum and zinc parts.

**GRACO INC. P.O. BOX 1441 MINNEAPOLIS, MN 55440-1444**

# WARNING

**HIGH PRESSURE SPRAY CAN CAUSE SERIOUS INJURY.  
FOR PROFESSIONAL USE ONLY. OBSERVE ALL WARNINGS.**

**Read and understand all instruction manuals before operating equipment.**

## FLUID INJECTION HAZARD

### General Safety

This equipment generates very high fluid pressure. Spray from the gun, leaks or ruptured components can inject fluid through your skin and into your body and cause extremely serious bodily injury, including the need for amputation. Also, fluid injected or splashed into the eyes or on the skin can cause serious damage.

NEVER point the spray gun at anyone or at any part of the body. NEVER put hand or fingers over the spray tip. NEVER try to "blow back" paint; this is NOT an air spray system.

ALWAYS have the tip guard in place on the spray gun when spraying.

ALWAYS follow the **Pressure Relief Procedure**, below, before cleaning or removing the spray tip or servicing any system equipment.

NEVER try to stop or deflect leaks with your hand or body.

Be sure equipment safety devices are operating properly before each use.

### Medical Alert—Airless Spray Wounds

If any fluid appears to penetrate your skin, get **EMERGENCY MEDICAL CARE AT ONCE. DO NOT TREAT AS A SIMPLE CUT.** Tell the doctor exactly what fluid was injected.

**Note to Physician:** *Injection in the skin is a traumatic injury. It is important to treat the injury surgically as soon as possible. Do not delay treatment to research toxicity. Toxicity is a concern with some exotic coatings injected directly into the blood stream. Consultation with a plastic surgeon or reconstructive hand surgeon may be advisable.*

### Spray Gun Safety Devices

Be sure all gun safety devices are operating properly before each use. Do not remove or modify any part of the gun; this can cause a malfunction and result in serious bodily injury.

#### Safety Latch

Whenever you stop spraying, even for a moment, always set the gun safety latch in the closed or "safe" position, making the gun inoperative. Failure to set the safety latch can result in accidental triggering of the gun.

#### Diffuser

The gun diffuser breaks up spray and reduces the risk of fluid injection when the tip is not installed. Check diffuser operation regularly. Follow the **Pressure Relief Procedure**, below, then remove the spray tip. Aim the gun into a metal pail, holding the gun firmly to the pail. Using the lowest possible pressure, trigger the gun. If the fluid emitted is not diffused into an irregular stream, replace the diffuser immediately.

#### Tip Guard

ALWAYS have the tip guard in place on the spray gun while spraying. The tip guard alerts you to the fluid injection hazard and helps reduce, but does not prevent accidentally placing your fingers or any part of your body close to the spray tip.

#### Spray Tip Safety

Use extreme caution when cleaning or changing spray tips. If the spray tip clogs while spraying, engage the gun safety latch immediately. ALWAYS follow the **Pressure Relief Procedure** and then remove the spray tip to clean it.

NEVER wipe off build-up around the spray tip until pressure is fully relieved and the gun safety latch is engaged.

### Pressure Relief Procedure

To reduce the risk of serious bodily injury, including fluid injection, splashing fluid or solvent in the eyes or on the skin, or injury from moving parts or electric shock, always follow this procedure whenever you shut off the sprayer, when checking or servicing any part of the spray system, when installing, cleaning or changing spray tips, and whenever you stop spraying. (1) Engage the gun safety latch. (2) Turn the ON/OFF switch to OFF. (3) Unplug the power supply cord. (4) Disengage the gun safety latch. (5) Hold a metal part of the gun firmly to the side of a grounded metal pail, and trigger the gun to relieve pressure. (6) Engage the gun safety latch. (7) Open the drain valve, having a container ready to catch the drainage. (8) Leave the drain valve open until you are ready to spray again.

If you suspect that the spray tip or hose is completely clogged, or that pressure has not been fully relieved after following the steps above, VERY SLOWLY loosen the tip guard retaining nut or hose end coupling and relieve pressure gradually, then loosen completely. Now clear the tip or hose.

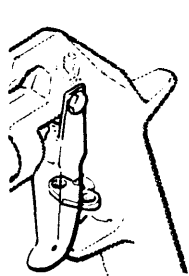

ENGAGE SAFETY



TURN SWITCH TO OFF

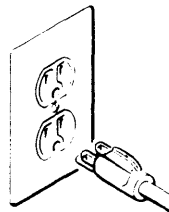

UNPLUG CORD

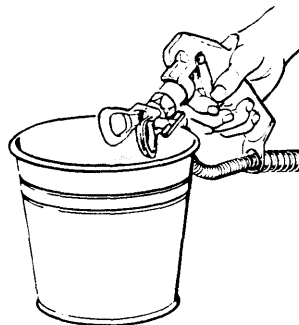

DISENGAGE SAFETY  
AND TRIGGER GUN;  
ENGAGE SAFETY AGAIN

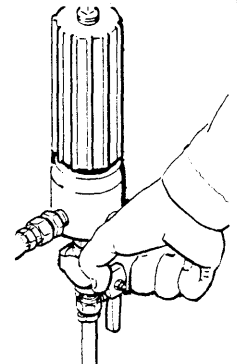

OPEN DRAIN VALVE

## EQUIPMENT MISUSE HAZARD

### General Safety

Any misuse of the spray equipment or accessories, such as overpressurizing, modifying parts, using incompatible chemicals and fluids, or using worn or damaged parts, can cause them to rupture and result in fluid injection, splashing in the eyes or on the skin, or other serious bodily injury, fire, explosion or property damage.

NEVER alter or modify any part of this equipment; doing so could cause it to malfunction.

CHECK all spray equipment regularly and repair or replace worn or damaged parts immediately.

Read and follow the fluid and solvent manufacturer's literature regarding the use of protective clothing and equipment.

### System Pressure

This sprayer can develop *3000 psi (210 bar) MAXIMUM WORKING PRESSURE*. Be sure that all spray equipment and accessories are rated to withstand the maximum working pressure of this sprayer. DO NOT exceed the maximum working pressure of any component or accessory used in the system.

### Fluid and Solvent Compatibility

BE SURE that all fluids and solvents used are chemically compatible with the wetted parts shown in the Technical Data on the back cover. Always read the fluid and solvent manufacturer's literature before using them in this sprayer.

## HOSE SAFETY

High pressure fluid in the hoses can be very dangerous. If the hose develops a leak, split or rupture due to any kind of wear, damage or misuse, the high pressure spray emitted from it can cause a fluid injection injury or other serious bodily injury or property damage.

**ALL FLUID HOSES MUST HAVE SPRING GUARDS ON BOTH ENDS!** The spring guards help protect the hose from kinks or bends at or close to the coupling which can result in hose rupture.

TIGHTEN all fluid connections securely before each use. High pressure fluid can dislodge a loose coupling or allow high pressure spray to be emitted from the coupling.

NEVER use a damaged hose. Before each use, check the entire hose for cuts, leaks, abrasion, bulging cover, or damage or movement of the hose couplings. If any of these conditions exist, replace the hose immediately. DO NOT try to recouple high pressure hose or mend it with tape or any other device. A repaired hose cannot contain the high pressure fluid.

HANDLE AND ROUTE HOSES CAREFULLY. Do not pull on hoses to move equipment. Do not use fluids or solvents which are not compatible with the inner tube and cover of the hose. DO NOT expose Graco hose to temperatures above 180°F (82°C) or below -40°F (-40°C).

### Hose Grounding Continuity

Proper hose grounding continuity is essential to maintaining a grounded spray system. Check the electrical resistance of your fluid hoses at least once a week. If your hose does not have a tag on it which specifies the maximum electrical resistance, contact the hose supplier or manufacturer for the maximum resistance limits. Use a resistance meter in the appropriate range for your hose to check the resistance. If the resistance exceeds the recommended limits, replace it immediately. An ungrounded or poorly grounded hose can make your system hazardous. Also read **FIRE OR EXPLOSION HAZARD**.

## FIRE OR EXPLOSION HAZARD

Static electricity is created by the flow of fluid through the pump and hose. If every part of the spray equipment is not properly grounded, sparking may occur, and the system may become hazardous. Sparking may also occur when plugging in or unplugging a power supply cord. Sparks can ignite fumes from solvents and the fluid being sprayed, dust particles and other flammable substances, whether you are spraying indoors or outdoors, and can cause a fire or explosion and serious bodily injury and property damage. Always plug the sprayer into an outlet at least 20 feet (6 m) away from the sprayer and the spray area. Do not plug in or unplug any power supply cords in the spray area when there is any chance of igniting fumes still in the air.

If you experience any static sparking or even a slight shock while using this equipment, **STOP SPRAYING IMMEDIATELY**. Check the entire system for proper grounding. Do not use the system again until the problem has been identified and corrected.

### Grounding

To reduce the risk of static sparking, ground the sprayer and all other spray equipment used or located in the spray area. CHECK your local electrical code for detailed grounding instructions for your area and type of equipment. BE SURE to ground all of this spray equipment:

1. *Sprayer*: plug the power supply cord, or extension cord, each equipped with an undamaged three-prong plug, into a properly grounded outlet. Do not use an adapter. All extension cords must have three wires and be rated for 15 amps.
2. *Fluid hoses*: use only grounded hoses with a maximum of 500 feet (150 m) combined hose length to ensure grounding continuity. Refer to **Hose Grounding Continuity**.
3. *Spray gun*: obtain grounding through connection to a properly grounded fluid hose and sprayer.
4. *Supply container*: according to local code.
5. *Object being sprayed*: according to local code.
6. *All solvent pails* used when flushing, according to local code. Use *only metal pails*, which are conductive. Do not place the pail on a non-conductive surface, such as paper or cardboard, which interrupts the grounding continuity.
7. *To maintain grounding continuity when flushing or relieving pressure*, always hold a metal part of the gun firmly to the side of a *grounded metal* pail, then trigger the gun.

### Flushing Safety

Reduce the risk of fluid injection injury, static sparking, or splashing by following the flushing procedure given on page 9 of this manual. Follow the **Pressure Relief Procedure** on page 2, and *remove the spray tip before flushing*. Hold a metal part of the gun firmly to the side of a *grounded metal* pail and use the lowest possible fluid pressure during flushing.

## MOVING PARTS HAZARD

Moving parts can pinch or amputate your fingers or other body parts. KEEP CLEAR of moving parts when starting or operating the sprayer. Unplug the sprayer, and follow the **Pressure Relief Procedure** on page 2, before checking or servicing any part of the sprayer to prevent it from starting accidentally.

## IMPORTANT

United States Government safety standards have been adopted under the Occupational Safety and Health Act. These standards—particularly the General Standards, Part 1910, and the Construction Standards, Part 1926—should be consulted.

# AVERTISSEMENT

La pulvérisation à haute pression peut causer des blessures très graves.  
Réservé exclusivement à l'usage professionnel. Observer toutes les consignes de sécurité.  
Bien lire et bien comprendre tous les manuels d'instructions avant d'utiliser le matériel.

## RISQUES D'INJECTION

### Consignes générales de sécurité

Cet appareil produit un fluide à très haute pression. Le fluide pulvérisé par le pistolet ou le fluide sous pression provenant de fuites ou de ruptures peut pénétrer sous la peau ou à l'intérieur du corps et entraîner des blessures très graves, voir même une amputation. Même sans être sous pression, le fluide éclaboussant ou entrant dans les yeux peut aussi entraîner des blessures graves.

NE JAMAIS pointer le pistolet vers quelqu'un ou vers une partie quelconque du corps. NE JAMAIS mettre la main ou les doigts sur l'ajutage du pulvérisateur. NE JAMAIS essayer de "refouler" la peinture. Cet appareil N'est PAS un compresseur pneumatique.

TOUJOURS garder la protection de l'ajutage en place sur le pistolet pendant la pulvérisation.

TOUJOURS observer la Marche à Suivre pour Détendre la Pression donnée plus loin, avant de nettoyer ou d'enlever l'ajutage du pulvérisateur, ou d'effectuer un travail quelconque sur une partie de l'appareil.

NE JAMAIS essayer d'arrêter ou de dévier les fuites avec la main ou le corps.

Avant chaque utilisation, bien s'assurer que les dispositifs de sécurité fonctionnent correctement.

### Soins médicaux

En cas de pénétration de fluide sous la peau: **DEMANDER IMMEDIATEMENT DES SOINS MEDICAUX D'URGENCE. NE PAS SOIGNER CETTE BLESSURE COMME UNE SIMPLE COUPURE.**

*Avis au medecin: La pénétration des fluides sous la peau est un traumatisme. Il est important de traiter chirurgicalement cette blessure immédiatement. Ne pas retarder le traitement pour effectuer des recherches sur la toxicité. Certains revêtements exotiques sont dangereusement toxiques quand ils sont injectés directement dans le sang. Il est souhaitable de consulter un chirurgien esthétique ou un chirurgien spécialisé dans la reconstruction des mains.*

### Dispositifs de sécurité du pistolet

Avant chaque utilisation, bien s'assurer que tous les dispositifs de sécurité du pistolet fonctionnent correctement. Ne pas

enlever ni modifier une partie quelconque du pistolet; ceci risquerait d'entraîner un mauvais fonctionnement et des blessures graves.

### Verrou de sécurité

A chaque fois que l'on s'arrête de pulvériser, même s'il s'agit d'un court instant, toujours mettre le verrou de sécurité du pistolet sur la position "fermée" ou "sécurité" ("safe") pour empêcher le pistolet de fonctionner. Si le verrou de sécurité n'est pas mis, le pistolet peut se déclencher accidentellement.

### Diffuser

Le diffuseur du pistolet sert à diviser le jet et à réduire les risques d'injection accidentelle quand l'ajutage n'est pas en place. Vérifier le fonctionnement du diffuseur régulièrement. Pour cette vérification, détendre la pression en observant la Marche à Suivre pour Détendre la Pression donnée plus loin puis enlever l'ajutage du pulvérisateur. Pointer le pistolet dans un seau en métal, en le maintenant fermement contre le seau. Puis, en utilisant la pression la plus faible possible, appuyer sur la gachette du pistolet. Si le fluide projeté n'est pas diffusé sous forme de jet irrégulier, remplacer immédiatement le diffuseur.

### Protection de l'ajutage

TOUJOURS maintenir la protection de l'ajutage en place sur le pistolet du pulvérisateur pendant la pulvérisation. La protection de l'ajutage attire l'attention sur les risques d'injection et contribue à éviter que les doigts ou une partie quelconque du corps ne passe accidentellement à proximité immédiate de l'ajutage du pulvérisateur.

### Consignes de sécurité concernant l'ajutage du pulvérisateur

Faire extrêmement attention à l'occasion du nettoyage ou du remplacement des ajutages du pulvérisateur. Si l'ajutage se bouche pendant la pulvérisation, mettre immédiatement le verrou de sécurité du pistolet. TOUJOURS bien observer la Marche à Suivre pour Détendre la Pression puis enlever l'ajutage du pulvérisateur pour le nettoyer.

NE JAMAIS essayer ce qui s'est accumulé autour de l'ajutage du pulvérisateur avant que la pression ne soit complètement tombée et que le verrou de sécurité du pistolet ne soit engagé.

### Marche à Suivre pour Détendre la Pression

Pour réduire les risques de blessures graves, y compris les blessures par injection de fluide ou celles causées par des pièces en mouvement ou par électrocution, toujours bien observer cette marche à suivre à chaque fois que l'on arrête le pulvérisateur, à l'occasion de la vérification ou de la réparation d'une pièce de l'appareil de pulvérisation, à l'occasion de l'installation, du nettoyage ou du remplacement des ajutages et d'une manière générale à chaque arrêt. 1) Engager le verrou de sécurité du pistolet. 2) Mettre l'interrupteur Marche-Arrêt sur ARRET ("OFF"). 3) Débrancher le cordon d'alimentation. 4) Désengager le verrou de sécurité du pistolet. 5) En maintenant une partie métallique du pistolet fermement appuyée contre le côté d'un seau en métal, appuyer sur la gachette du pistolet pour libérer la pression. 6) Engager le verrou de sécurité du pistolet. 7) Ouvrir le robinet de purge en prenant soin d'avoir un récipient prêt à récupérer le liquide. 8) Laisser le robinet de purge ouvert jusqu'à ce que le pulvérisateur soit de nouveau prêt à être utilisé.

Si l'on soupçonne que l'ajutage du pulvérisateur ou le tuyau est complètement bouché, ou que la pression n'a pas été complètement libérée après avoir procédé aux opérations ci-dessus, desserrer TRES LENTEMENT l'écrou de retenue de la protection de l'ajutage ou le raccord du bout du tuyau et libérer progressivement la pression, puis terminer le desserrage. On peut maintenant déboucher l'ajutage ou le tuyau.

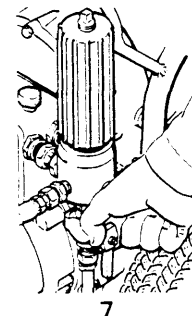
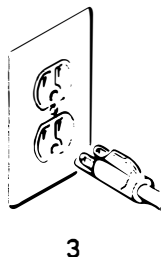
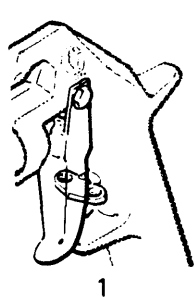

## RISQUES EN CAS DE MAUVAISE UTILISATION DU MATERIEL

### Consignes générales de sécurité

Toute utilisation anormale de l'appareil de pulvérisation ou des accessoires comme, par exemple, la mise sous une pression excessive, les modifications de pièces, l'utilisation de produits chimiques et de matières incompatibles et l'utilisation de pièces usées ou abîmées peut causer des dégâts à l'appareil ou des ruptures de pièces et entraîner une injection de liquide ou d'autres blessures sérieuses, un incendie, une explosion ou d'autres dégâts.

NE JAMAIS altérer ou modifier une pièce de cet appareil; ceci risquerait d'entraîner son mauvais fonctionnement.

VERIFIER régulièrement tout l'appareil de pulvérisation et ses équipements et réparer ou remplacer immédiatement les pièces usées ou abîmées.

### Pression

Ce pulvérisateur peut produire une *PRESSION MAXIMUM DE TRAVAIL 210 bar (3000 lb/po.<sup>2</sup>)*. S'assurer que tous les éléments du pulvérisateur et ses accessoires sont conçus pour résister à la pression maximum de travail de ce pulvérisateur. NE PAS dépasser la pression maximum de travail d'aucun des éléments ou accessoires utilisés avec cet appareil.

### Compatibilité chimique des corps

BIEN S'ASSURER que tous les corps des solvants utilisés sont chimiquement compatibles avec les parties mouillées indiquées dans les "Données techniques", au dos de la couverture. Toujours lire soigneusement les documents et brochures du fabricant des matières et solvants utilisés avant de s'en servir dans ce pulvérisateur.

## MESURES DE SECURITE CONCERNANT LES TUYAUX FLEXIBLES

Le fluide à haute pression circulant dans les tuyaux peut être très dangereux. En cas de fuite sur le tuyau, même minuscule, de fissure, déchirure ou rupture à la suite de l'usure, de dégâts ou d'une mauvaise utilisation, les projections de fluide haute pression qui en proviennent peuvent entraîner des blessures graves par pénétration sous la peau ou par contact, ainsi que des dégâts matériels.

**TOUS LES TUYAUX FLEXIBLES DOIVENT AVOIR DES RESSORTS SPIRALE DE PROTECTION!** Les spirales de protection contribuent à éviter la formation de pliures, de boucles ou de nœuds sur les tuyaux qui pourraient entraîner la rupture du tuyau à l'endroit du raccord ou à son voisinage.

**SERRER FERMEMENT** tous les raccords avant chaque utilisation. Le fluide sous pression peut faire sauter un raccord desserré ou produire un jet à haute pression s'échappant par le raccord.

NE JAMAIS utiliser un tuyau endommagé. Avant chaque utilisation, vérifier entièrement chaque tuyau pour déceler les coupures, fuites, abrasions, boursouffures de l'enveloppe ou toute autre détérioration ou jeu des raccords. Si l'on constate l'une de ces détériorations, il faut remplacer le tuyau immédiatement. NE PAS essayer de refaire le raccord d'un tuyau haute pression ni de réparer le tuyau avec du ruban adhésif ou

par tout autre moyen. Un tuyau réparé ne peut pas résister au fluide sous pression.

**MANIPULER LES TUYAUX AVEC PRECAUTION ET CHOISIR SOIGNEUSEMENT LEUR CHEMIN.** Ne pas déplacer le matériel en tirant sur le tuyau. Ne pas utiliser de matières ou de solvants qui ne sont pas compatibles avec l'enveloppe intérieure ou extérieure du tuyau. NE PAS exposer le tuyau à des températures supérieures à 82°C (180°F) ou inférieures à -40°C (-40°F).

### Continuité de la mise à la terre des tuyaux

Une bonne continuité de la mise à la terre des tuyaux est essentielle pour maintenir la mise à la terre de l'ensemble de vaporisation. Vérifiez la résistance électrique de vos tuyaux à fluides et à air, au moins une fois par semaine. Si votre tuyau ne comporte pas d'étiquette qui précise la résistance électrique, prenez contact avec le fournisseur de tuyaux ou le fabricant pour avoir les limites de résistance. Utilisez un mètre de résistance de la gamme appropriée pour votre tuyau et vérifiez la résistance. Si celle-ci dépasse les limites recommandées, remplacez le tuyau immédiatement. Un tuyau sans mise à la terre ou avec une mise à la terre incorrecte peut entraîner des risques pour votre système. Lisez aussi **LES RISQUES D'INCENDIE OU D'EXPLOSION** ci-dessus.

## RISQUES D'INCENDIE OU D'EXPLOSION

De l'électricité statique est produite par le passage du fluide à grande vitesse dans la pompe et dans les tuyaux. Si toutes les pièces de l'appareil de pulvérisation ne sont pas convenablement reliées à la masse ou à la terre, des étincelles peuvent se produire et l'appareil risque d'être dangereux. Des étincelles peuvent également se produire à l'occasion du branchement ou du débranchement du cordon d'alimentation. Les étincelles sont suffisantes pour allumer les vapeurs de solvants et le fluide pulvérisé, les fines particules de poussière ainsi que d'autres substances inflammables, quand on pulvérise à l'intérieur ou à l'extérieur, et elles peuvent causer un incendie ou une explosion, ainsi que des blessures graves et des dégâts matériels. Toujours brancher le pulvérisateur dans une prise se trouvant à au moins 6 m (20 pieds) de l'appareil et de l'endroit où se fait la pulvérisation. Ne pas brancher ou débrancher un cordon d'alimentation quel qu'il soit dans la zone où se fait la pulvérisation quand il y a le moindre risque que des vapeurs encore présentes dans l'air prennent feu.

### Mise à la terre ou à la masse

Pour réduire les risques de production d'étincelles d'électricité statique, le pulvérisateur et tous les équipements utilisés ou se trouvant dans la zone de pulvérisation doivent être reliés à la terre ou à la masse. Pour connaître le détail des instructions de mise à la terre dans la région et le type particulier d'équipement, CONSULTER le code ou les réglementations électriques locales. S'ASSURER que tous les équipements de pulvérisation suivants sont bien reliés à la terre:

1. *Pulvérisateur:* Brancher le cordon d'alimentation ou la rallonge qui doivent être équipés d'une prise à 3 fiches en bon état, dans une prise de courant convenablement mise à la terre. Ne pas utiliser d'adaptateur. Toutes les rallonges doivent avoir 3 fils et être prévues pour 15 ampères.

2. *Tuyaux flexibles:* Afin d'assurer la continuité de la mise à la terre, n'utiliser que des tuyaux comportant une mise à la terre et ayant une longueur maximum combinée de 150 m (1500 pieds). Se reporter également au paragraphe "Continuité du circuit de mise à la terre des tuyaux".

3. *Pistolet:* Réaliser la mise à la terre en le raccordant à un tuyau flexible et à un pulvérisateur déjà convenablement reliés à la terre.

4. *Objets, matériel ou surfaces recevant la pulvérisation:* observer le code ou les réglementations locales.

5. *Tous les seaux de solvants* utilisés pour le rincage: observer le code ou les réglementations locales. *N'utiliser que des seaux métalliques* conducteurs de l'électricité. Ne pas mettre le seau sur une surface non conductrice comme sur du papier ou du carton car cela interromprait la continuité de la mise à la terre.

6. *Pour conserver la continuité de la mise à la terre quand on rince le matériel ou quand on libère la pression,* toujours maintenir une partie métallique du pistolet fermement appuyée contre le côté d'un seau *en métal* puis appuyer sur la détente du pistolet.

### Mesures de Sécurité concernant le Rincage

Pour réduire les risques de blessures par pénétration de la peau et les risques dus aux étincelles d'électricité statique ou aux éclaboussures, observer la marche à suivre pour le rincage donnée à la page 9 de ce manuel. Observer la "**Marche à Suivre pour Détendre la Pression**" donnée à la page 4 en enlever l'ajutage du pulvérisateur avant le rincage. Maintenir une partie métallique du pistolet fermement appuyée contre le côté d'un seau *en métal* et utiliser la pression la plus faible possible pendant le rincage.

# ADVERTENCIA

**EL ROCIADO A ALTA PRESION PUEDE CAUSAR GRAVES LESIONES.  
SOLO PARA USO PROFESIONAL. RESPETE LOS AVISOS DE ADVERTENCIA.**

**Lea y entienda todo el manual de instrucciones antes de manejar el equipo.**

## PELIGRO DE INYECCION DE FLUIDO

### Seguridad general

Este equipo genera un fluido a una presión muy alta. El rociado de la pistola, los escapes de fluido o roturas de los componentes pueden inyectar fluido en la piel y el cuerpo y causar lesiones extremadamente graves, incluyendo a veces la necesidad de amputación. También, el fluido inyectado o salpicado en los ojos puede causar graves daños.

**NUNCA** apuntar la pistola hacia alguien o alguna parte del cuerpo. **NUNCA** colocar la mano o los dedos encima de la boquilla. **NUNCA** tratar de "hacer retornar la pintura"; este NO es un sistema de rociado de aire.

**SIEMPRE** tener colocado el protector de la boquilla en la pistola mientras se está pulverizando.

**SIEMPRE** seguir el procedimiento de descarga de presión, dado más abajo, antes de limpiar o sacar la boquilla o de dar servicio a cualquier equipo del sistema.

**NUNCA** tratar de parar o desviar los escapes con la mano o el cuerpo.

Asegurar que todos los aparatos de seguridad del equipo están funcionando bien antes de cada uso.

### Tratamiento médico

Si pareciera que un poco de fluido penetró la piel, conseguir **TRATAMIENTO MEDICO DE URGENCIA DE INMEDIATO. NO TRATAR LA HERIDA COMO UN SIMPLE CORTE.** Decir al médico exactamente cual fluido fue.

**Aviso al médico:** Si se llega a inyectar este fluido en la piel se causa una lesión traumática. Es importante tratar quirúrgicamente la lesión a la brevedad posible. No demorar el tratamiento para investigar la toxicidad. La toxicidad es algo de suma importancia en algunas pinturas exóticas cuando se inyectan directamente al torrente sanguíneo. Será conveniente consultar a un especialista en cirugía plástica o reconstructiva de las manos.

### Aparatos de seguridad de la pistola pulverizadora

Asegurar que todos los aparatos protectores de la pistola están funcionando bien antes de cada uso. No sacar ni

modificar ninguna pieza de la pistola pues podría causar el malfuncionamiento de la misma con las consiguientes lesiones personales.

### Pestillo de seguridad

Cada vez que se deje de pulverizar, aunque sea por un breve momento, siempre colocar el pestillo de seguridad en la posición "cerrada", lo que deja la pistola inoperante. El no hacerlo puede llevar al disparo imprevisto de la pistola.

### Difusor

El difusor de la pistola dispersa el chorro pulverizado y reduce el riesgo de inyección cuando no está instalada la boquilla. Revisar con regularidad el funcionamiento del difusor. Seguir el procedimiento de descarga de presión, dado más abajo, y después sacar la boquilla. Apuntar la pistola a un balde metálico, sosteniéndola bien firme contra él. Utilizando la presión más bajo posible, disparar la pistola. Si el fluido emitido *no sale disperso* en un chorro irregular, reemplazar de inmediato el difusor.

### Protector de la boquilla

**SIEMPRE** tener el protector de la boquilla colocado en la pistola mientras se está pulverizando. Este protector llama la atención contra el peligro de inyección y ayuda a prevenir la colocación accidental de los dedos o cualquier otra parte del cuerpo cerca de la boquilla.

### Seguridad de la boquilla pulverizadora

Tener mucho cuidado al limpiar o cambiar las boquillas. Si llegara a obstruirse mientras está pulverizando, enganchar el pestillo de la pistola de inmediato. **SIEMPRE** seguir el procedimiento de descarga de presión y después sacar la boquilla para limpiarla.

**NUNCA** limpiar la acumulación de pintura alrededor de la boquilla antes de que se haya descargado por completo la presión y el pestillo esté enganchado.

## Procedimiento de descarga de presión

Para reducir el riesgo de sufrir graves lesiones corporales, incluyendo inyección o lesiones causadas por piezas en movimiento o choque eléctrico, siempre seguir este procedimiento al apagar la máquina pulverizadora, al revisar o dar servicio a cualquier parte del sistema de pulverización, al instalar, limpiar o cambiar las boquillas, y cada vez que se deja de pulverizar. (1) Enganchar el pestillo de la pistola. (2) Mover el interruptor eléctrico (ON/OFF) a la posición OFF (apagado). (3) Desenchufar el cordón eléctrico. (4) Desenganchar el pestillo de la pistola. (5) Sujetar una parte metálica de la pistola bien firme contra un balde de metal, y disparar la pistola para descargar la presión. (6) Enganchar el pestillo de la pistola. (7) Abrir la válvula de drenaje y tener listo un recipiente para recibir la pintura. (8) Dejar la válvula de drenaje abierta hasta que se esté nuevamente listo para pulverizar.

Si se sospecha que la boquilla o la manguera está completamente obstruida, o que no se ha descargado por completo la presión después de haber seguido el procedimiento anterior, aflojar **MUY LENTAMENTE** la tuerca de retención del protector de la boquilla o acoplamiento de la punta de la manguera y descargar gradualmente la presión, después, aflojarlo por completo. Luego, despejar la boquilla o la manguera.

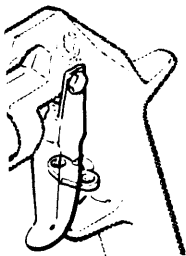

1



2

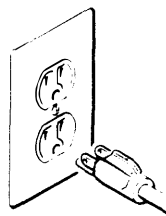

3

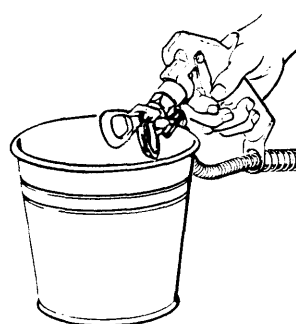

4,5,6

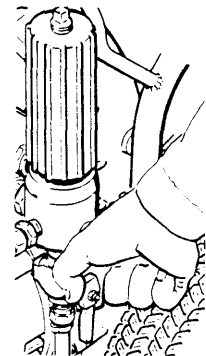

7

## PELIGRO POR MAL USO DEL EQUIPO

### Seguridad general

Cualquier mal uso del equipo pulverizador o los accesorios, tal como sobrepresurización, modificación de piezas, uso de materiales y productos químicos incompatibles, o utilización de piezas dañadas o desgastadas, puede hacer que se rompan y causen la inyección de fluido u otras lesiones corporales graves, incendio, explosión o daño a la propiedad.

NUNCA alterar o modificar ninguna pieza de este equipo; el hacerlo podría causar una avería.

REVISAR con regularidad el equipo pulverizador y reparar o reemplazar de inmediato las piezas dañadas o desgastadas.

### Presión del sistema

Esta pulverizadora puede desarrollar 210 barías (3000 psi) de **PRESIÓN DE TRABAJO MÁXIMA**. Asegurar que todo el equipo pulverizador y sus accesorios tienen la capacidad para aguantar la presión máxima de trabajo de esta pulverizadora. NO exceder la presión máxima de trabajo de ningún componente o accesorio de este sistema.

### Compatibilidad de material

ASEGURAR que todos los materiales y solventes usados son químicamente compatibles con las piezas mojadas ilustradas en la hoja de datos técnicos en la contratapa. Siempre leer las instrucciones del fabricante del material y solvente antes de usarlos en esta pulverizadora.

## SEGURIDAD EN EL USO DE LAS MANGUERAS

El fluido que pasa a alta presión por las mangueras puede ser muy peligroso. Si en la manguera se desarrolla un escape pequeño, una rotura o rajadura debido a cualquier tipo de desgaste, daño o maltrato, el chorro a alta presión emitido por allí puede causar una lesión por inyección u otras lesiones corporales graves o daño a la propiedad.

**¡TODAS LAS MANGUERAS PARA FLUIDOS TIENEN QUE TENER GUARDAS DE RESORTE!** Estas protegen las mangueras contra dobleces o retorceduras en los acoplamientos o cerca de ellos, los que podrían traducirse en roturas de la manguera.

Antes de usarlas, APRETAR bien firmes todas las conexiones. El fluido a alta presión puede desalojar un acoplamiento suelto o dejar que por él escape un chorro a alta presión.

NUNCA usar una manguera que está dañada. Siempre, revisarla en busca de cortaduras, escapes, abrasión, cubierta abultada, o acoplamientos sueltos o dañados. Si llegara a encontrarse cualquiera de estas condiciones, reemplazar de inmediato la manguera. NO intentar reacoplar una manguera de alta presión o enmendarla con cinta adhesiva u otro material similar. Una manguera que ha sido remendada no aguante el fluido a alta presión.

MANEJAR Y PASAR CUIDADOSAMENTE LAS MANGUERAS. No tirar de las mangueras para mover el equipo. No usar materiales o solventes que sean incompatibles con el tubo interno y la cubierta de la manguera. NO exponer las mangueras a temperaturas sobre 82°C (180°F) o bajo -40°C (-40°F).

### Continuidad del circuito de puesta a tierra de la manguera

La continuidad del circuito de puesta a tierra apropiado es esencial para mantener conectado a tierra el sistema pulverizador. Es indispensable revisar la resistencia eléctrica de las mangueras de aire y de fluido por lo menos una vez a la semana. Si la manguera no tiene una etiqueta en la cual se especifica la resistencia eléctrica, ponerse en contacto con el proveedor o fabricante de la manguera para la información sobre los límites de resistencia. Usar un metro de resistencia en la gama apropiada para comprobar la resistencia; si excede los límites recomendados, reemplazarla de inmediato. Es muy arriesgado tener una manguera sin puesta a tierra o con la puesta a tierra en malas condiciones. Leer también la información sobre **RIESGO DE INCENDIO O EXPLOSION**, más arriba.

## PELIGRO DE INCENDIO O EXPLOSION

El flujo a alta velocidad del fluido al pasar por la bomba y manguera crea electricidad estática. Si todas las partes del equipo pulverizador no tienen buena tierra, pueden ocurrir chispas, convirtiendo al sistema en algo peligroso. También, pueden producirse chispas al enchufar o desenchufar el cordón eléctrico. Estas chispas pueden inflamar los vapores de los solventes y el chorro de fluido pulverizado, partículas de polvo y otras sustancias inflamables, sea al aire libre o bajo techo, lo que podría causar una explosión o incendio y graves lesiones corporales y daños a la propiedad. Enchufar siempre la pulverizadora a un tomacorriente que se encuentre a por lo menos 6 m (20 pies) de la máquina y del área que se va a rociar. No enchufar o desenchufar ningún cordón eléctrico en el lugar donde se está rociando cuando todavía exista la posibilidad de que queden vapores inflamables en el aire.

### Puesta a tierra

Para reducir el riesgo de chispas estáticas, conectar a tierra la pulverizadora y todo el otro equipo de pulverizar que se use o se encuentre en el lugar que se va a rociar. CONSULTAR el código eléctrico de la localidad para las instrucciones sobre las conexiones a tierra exigidas para la zona y tipo de equipo. ASEGURAR de conectar a tierra todo este equipo pulverizador:

1. *Pulverizadora*: enchufar el cordón eléctrico, o cable extensor, cada uno con un enchuf de tres patas en buen estado, a un tomacorriente con puesta a tierra apropiado. No usar un adaptador. Todos los cables extensores tienen que tener tres hilos y una capacidad de 15 amperios.

2. *Mangueras para fluidos*: usar solamente mangueras con puesta a tierra de una longitud combinada de 150 m (500 pies), para asegurar buena continuidad a tierra. Referirse también al párrafo sobre continuidad a tierra de la manguera.

3. *Pistola*: hacer la puesta a tierra conectándola a una manguera de fluido y pulverizadora bien conectadas a tierra.

4. *Objeto que se está rociando*: de conformidad con el código local.

5. *Todos los baldes de solvente* usados durante el lavado, de conformidad con el código local. Usar *solamente baldes de metal*, que sean conductivos. No colocar el balde en una superficie no conductiva, como papel o cartón, que interrumpe la continuidad a tierra.

6. *Para mantener la continuidad a tierra durante el lavado o descarga de presión*, siempre apoyar una parte metálica de la pistola bien firme contra el costado del *balde de metal*, después apretar el gatillo.

### Seguridad durante el lavado

Reducir el riesgo de lesiones por inyección, chispas eléctricas o salpicaduras, siguiendo el procedimiento de lavado específico dado en la página 9 de este manual. Seguir el **procedimiento de descarga de presión** en la página 6, y quitar la *boquilla rociadora antes de lavar*. Apoyar una parte metálica de la pistola bien firme contra el costado de un *balde de metal* y usar la presión más baja posible de fluido durante el lavado.

## PELIGRO DE LAS PIEZAS MOVILES

Las piezas en movimiento pueden pinchar o amputar dedos u otras partes del cuerpo. MANTENERSE ALEJADO de las piezas en movimiento durante el arranque o funcionamiento de la pulverizadora. Desenchufar la pulverizadora y descargar la presión antes de revisarla o darle servicio, para impedir que arranque inesperadamente.

### IMPORTANT

Se han adoptado las normas de seguridad del gobierno de los Estados Unidos de Norteamérica bajo el Acta de Seguridad y Salud Ocupacional. Deberán consultarse estas normas, en especial las Generales, Parte 1910, y las Normas de Construcción, Parte 1926.

## SETUP

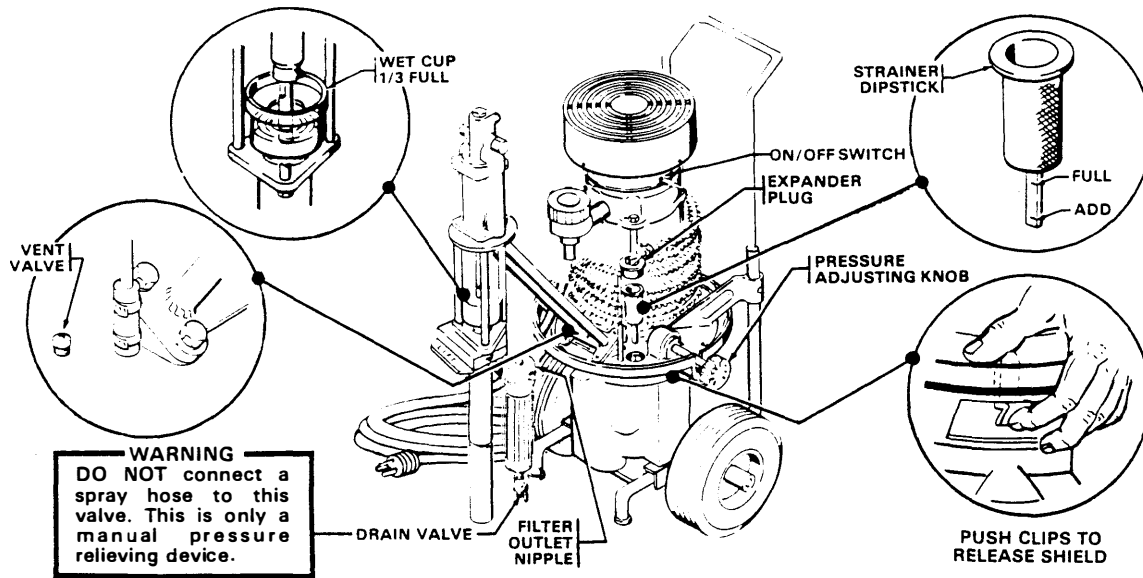

Fig 1

### 1. Check Hydraulic Fluid (Refer to Fig 1.)

- a. Push in on the two spring clips and lift the shield off of the sprayer.
- b. Remove the expander plug from the sump fill hole and lift strainer/dipstick out of the hole. Using a *clean, lint-free* cloth, wipe the dipstick clean, replace it in the sump hole, then remove it and check the fluid level. The fluid level should be between the ADD and FULL marks on the dipstick.
- c. If the fluid level is at or below the ADD mark, replace the strainer/dipstick in the sump hole and add approved hydraulic fluid through the hole as necessary to bring the level to the FULL mark. See Accessories on page 19 for approved hydraulic fluid. 1-3/4 pints will raise the level from ADD to FULL.

### 2. Connect Hose and Gun (Refer to Fig 1.)

- a. Remove the plastic cap plug from the filter outlet nipple and tightly screw the 50 ft (15.2 m) fluid hose onto the nipple.
- b. Tightly connect the whip hose between the fluid hose and the gun inlet connection.
- c. Don't use thread sealant, and don't install the spray tip yet!

### 3. Fill Packing Nut/Wet-Cup (See Fig 1.)

- a. Push in on the two spring clips and remove the sprayer shield.
- b. Fill the packing nut/wet-cup 1/3 full with Graco Throat Seal Liquid (TSL), supplied. Install the sprayer shield.

**WARNING**  
NEVER operate the sprayer without the shield installed. The shield encloses the fan and other moving parts which can cause serious bodily injury, including amputation. The shield also contains important WARNING information.

Operating the sprayer without the shield in place may cause it to overheat.

### 4. Check Electrical Service

- a. Be sure the electrical service is 120 V, 60 HzAC, 15 Amp (minimum) and that the outlet you use is properly grounded.

**NOTE:** A licensed electrician can rewire the sprayer for 230 volt service if necessary. See page 15.

- b. Use an extension cord which has 3 wires of a minimum 12 gauge size, and a maximum of 50 ft (15 m) long. Longer lengths may affect sprayer performance.

### 5. Plug in the Sprayer

- a. Be sure the ON/OFF switch is OFF. Refer to Fig 1. Then plug the cord into a grounded electrical outlet at least 20 ft (6 m) away from the spray area.

**WARNING**  
Proper electrical grounding is essential to reduce the risk of fire or explosion which can result in serious bodily injury and property damage. Refer to the warning section GROUNDING on page 3 for more detailed grounding instructions.

6. **Flush the pump** to remove the lightweight oil which was left in to protect pump parts after factory testing. See "Flushing Guidelines" on page 9 for flushing procedure.

7. **Prepare the paint** according to the manufacturer's recommendations.

- a. Remove any skin that may have formed.
- b. Stir the paint to dissolve hard pigments.
- c. Strain the paint through a fine nylon mesh bag (available at most paint dealers) to remove particles that could clog the filter or spray tip. *This is probably the most important step toward trouble-free spray painting.*



## FLUSHING GUIDELINES

### When to Flush

1. **New Sprayer.** The Sprayer is factory tested in lightweight oil which is left in to protect pump parts.  
**Before using water-base paint,** flush with mineral spirits, followed by soapy water, and then a clean water flush.  
**Before using oil-base paint,** flush with mineral spirits only.
2. **Changing Colors.** Flush with a compatible solvent such as mineral spirits or water.
3. **Changing from water-base to oil-base paint.** Flush with soapy water, then mineral spirits.
4. **Changing from oil-base to water-base paint.** Flush with mineral spirits, followed by soapy water, then a clean water flush.

5. **Storage.**  
**Water-base paint:** flush with water, then mineral spirits and leave the pump, hose and gun filled with mineral spirits. Shutoff and unplug the sprayer, open the drain valve to relieve pressure and leave open.  
**Oil-base paint:** flush with mineral spirits. Shutoff and unplug the sprayer, open the drain valve to relieve pressure and leave open.
6. **Startup after storage.**  
**Before using water-base paint,** flush out mineral spirits with soapy water and then a clean water flush.  
**When using oil-base paint,** flush out the mineral spirits with the fluid to be sprayed and the sprayer is ready to use.

### How to Flush

1. Engage the gun safety latch, turn the ON/OFF switch to OFF, release the gun safety, trigger the gun to relieve pressure, engage the gun safety and open the filter drain valve. See Fig 2.
2. Remove the filter bowl and screen; see manual 307-273 supplied. Clean the screen separately and install the bowl without the screen.

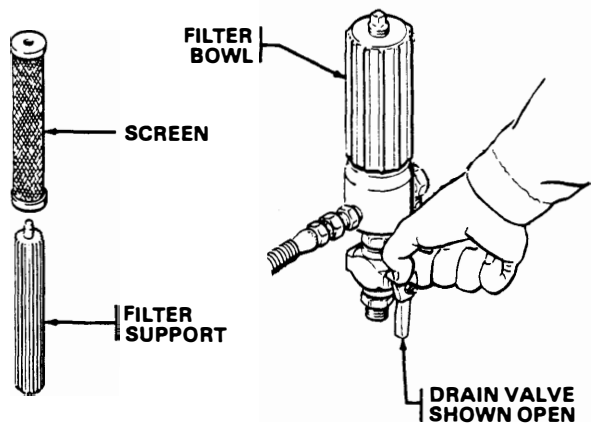

Fig 2

3. Close the filter drain valve.
4. Pour one-half gallon (2 liters) of compatible solvent into a bare metal pail. Put the suction tube in the pail.

### WARNING

To reduce the risk of static sparking and splashing, always remove the spray tip from the gun, and hold a metal part of the gun firmly to the side of a grounded metal pail when flushing.

5. Disengage the gun safety latch.
6. Point the spray gun into a metal waste container and with a metal part of the gun firmly touching the metal container, squeeze the gun trigger. **This procedure helps avoid splashing and static sparking, which can cause fire or explosion.** With the

gun triggered, turn the ON/OFF switch to ON and slowly turn the pressure adjusting knob clockwise **just until** the sprayer starts. Keep the gun triggered until clean solvent comes from the nozzle. Release the trigger and engage the gun safety latch. See Fig 3.

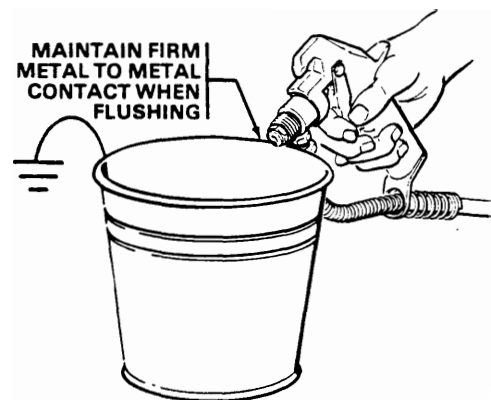

Fig 3

7. Check all fluid connections for leaks. If any leak, follow the **Pressure Relief Procedure Warning** on page 2. Now tighten the connections, start the sprayer, and recheck the connections for leaks.
8. Remove the suction tube from the pail. Disengage the gun safety and trigger the gun to force solvent from the hose. **Do not let the pump run dry for more than 30 seconds to avoid damaging the pump.** Then turn ON/OFF switch to OFF and engage the gun safety latch.
9. Unplug the power supply cord. Open the drain valve and leave open until you are ready to use the sprayer again. Unscrew the filter bowl and reinstall the clean screen. Reinstall the bowl, hand tight only.
10. If you have flushed with mineral spirits and are going to use a water-base paint, flush with soapy water followed by a clean water flush. Then repeat Step 1.

## OPERATION

### WARNING

#### Pressure Relief Procedure

To reduce the risk of serious bodily injury, including fluid injection, splashing in the eyes or on the skin, injury from moving parts or electric shock, always follow this procedure whenever you shut off the sprayer, when checking or servicing any part of the spray system, when installing, cleaning or changing spray tips, and whenever you stop spraying.

1. Engage the gun safety latch.
2. Turn the ON/OFF switch to OFF.
3. Unplug the power supply cord.
4. Disengage the gun safety latch.
5. Hold a metal part of the gun firmly to the side of a grounded metal pail, and trigger the gun to relieve pressure.
6. Engage the gun safety latch.
7. Open the drain valve, having a container ready to catch the drainage.
8. Leave the drain valve open until you are ready to spray again.

*If you suspect the spray tip or hose is completely clogged, or that pressure has not been fully relieved after following the steps above, VERY SLOWLY loosen the tip guard retaining nut or hose end coupling and relieve pressure gradually, then loosen completely. Now clear the tip or hose.*

#### 1. Prime the Sprayer with Paint.

- a. Close the filter drain valve.
- b. Don't install the spray tip yet!
- c. Put the suction tube into the paint container.
- d. Turn the pressure adjusting knob all the way counterclockwise to lower the pressure setting. Refer to Fig 1.
- e. Disengage the gun safety latch.
- f. Hold a metal part of the gun firmly against and aimed into a grounded metal waste container. See Fig 4. Squeeze the trigger and hold it open, turn the ON/OFF switch to ON, and slowly increase the pressure setting until the sprayer starts. Keep the gun triggered until all air is forced out of the system and the paint flows freely from the gun. Release the trigger and engage the safety.

**NOTE:** If the pump is hard to prime, place a container under the drain valve and open it. When fluid comes from the valve, close it. Then disengage the gun safety and proceed as in Step 1f, above.

- g. Check all fluid connections for leaks. If any are found, follow the **Pressure Relief Procedure Warning**, above, before tightening connections.

#### 2. Install the Spray Tip and Tip Guard

- a. Be sure the gun safety latch is engaged.

### WARNING

ALWAYS have the tip guard in place on the spray gun while spraying. The tip guard alerts you to the fluid injection hazard and helps reduce, but does not prevent, the risk of accidentally placing your fingers or any part of your body close to the spray tip.

- b. Install the spray tip. If using the Reverse-A-Clean IV, refer to manual 307-848, supplied with the gun.

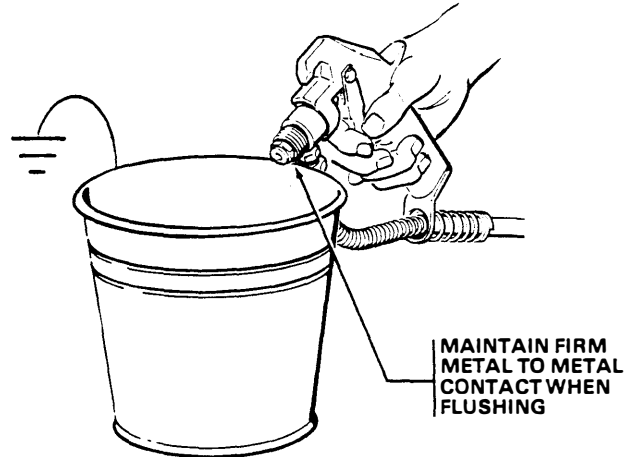

Fig 4

#### 3. Adjusting the Spray Pattern

- a. Increase the pressure adjusting knob setting just until spray from the gun is completely atomized. To avoid excessive overspray and fogging, and to decrease tip wear and extend the life of the sprayer, always use the lowest possible pressure needed to get the desired results.
- b. If more coverage is needed, use a larger tip rather than increasing the pressure.
- c. Test the spray pattern. To adjust the direction of the spray pattern, engage the gun safety and loosen the retaining nut. Position the tip guard horizontally for a horizontal pattern or vertically for a vertical pattern. Then tighten the retaining nut.

#### 4. Cleaning a Clogged Tip

##### WARNING

To reduce the risk of serious bodily injury from injection, use extreme caution when cleaning or changing spray tips. If the spray tip clogs while spraying, engage the gun safety latch immediately. Then follow the procedure below.

NEVER wipe off build-up around the spray tip until pressure is fully relieved and the gun safety latch is engaged.

- Clean the front of the tip frequently during the day's operation. *First*, follow the **Pressure Relief Procedure Warning** on page 10. Then use a solvent-soaked brush to keep fluid from building up and clogging the tip.
- If the spray tip does clog, release the gun trigger, and engage the gun safety latch.
- Model 226-333 and 226-336 only*  
Rotate the RAC IV handle 180°. See Fig 6. Disengage the gun safety and trigger the gun into a grounded waste container. Engage the gun safety again. Return the handle to the original position.

##### *Model 231-003 only*

VERY SLOWLY loosen the tip guard retaining nut or hose end coupling, and relieve pressure gradually, then loosen completely. Clear the tip or hose, then reassemble.

- Disengage the gun safety, and resume spraying.
- If the tip is still clogged*, engage the gun safety, shutoff and unplug the sprayer, and open the drain valve to relieve pressure. Remove the spray tip and clean it.

##### *Model 226-333 and 226-336 only*

Instructions for cleaning the RAV IV are given in manual 307-848.

## MAINTENANCE

- Check the packing nut/wet-cup daily.** First follow the **Pressure Relief Procedure Warning** on page 10. Be sure the wet-cup is 1/3 full of TSL at all times to help prevent fluid buildup on the piston rod and premature wear of packings. The packing nut should be tight enough to stop leakage, but no tighter. Overtightening may cause binding and excessive packing wear. Use a 1/4 in. diameter rod to adjust the nut.

**NOTE:** Normal seepage of hydraulic fluid past the hydraulic motor piston rod wiper will gradually fill the wet-cup. Check the wet-cup every eight hours to prevent overflow.

- Clean the fluid filter often** and whenever the sprayer is stored. First follow the **Pressure Relief Procedure Warning** on page 10. Refer to manual 307-273, supplied, for the cleaning procedure.
- Flush the sprayer at the end of each work day** and fill it with mineral spirits to help prevent pump corrosion and freezing. See "Flushing Guidelines" on page 9.

##### CAUTION

To help prevent pump corrosion and to avoid freezing, never leave water in the sprayer. Freezing can seriously damage the pump.

- For very short shutoff periods, leave the suction tube in the paint, follow the **Pressure Relief Procedure Warning** on page 10, and clean the spray tip.
- Coil the hose around the hose brackets when storing the sprayer, even for overnight, to help protect hose from damage.

##### WARNING

To reduce the risk of component rupture which can cause serious bodily injury, NEVER use worn or damaged hoses. Refer to the **Hose Safety Warning** on page 3.

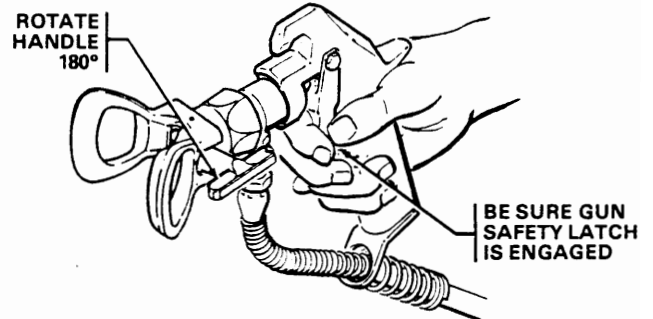

Fig 6

- Check the hydraulic fluid level occasionally.** Add fluid as necessary to keep the fluid level between the ADD and FULL marks on the dipstick. Refer to page 8.
- Change the hydraulic fluid every 2000 hours of operation or every 12 months, whichever comes first.** Also clean the hydraulic pump intake filter and replace the disposable filter in the return line. *First*, follow the **Pressure Relief Procedure Warning** on page 10, then remove the sprayer shield and follow the instructions under "Replacing the Electric Motor", page 14, to get at the filters, remove the old hydraulic fluid and clean the sump.
- Relieve fluid pressure when not using the sprayer to avoid the pump stalling out at the top of its stroke. If the pump stalls, follow the **Pressure Relief Procedure Warning** on page 10, remove the plug from the top of the hydraulic motor and push the spool all the way down. See Fig 7. Replace the plug and restart the sprayer.

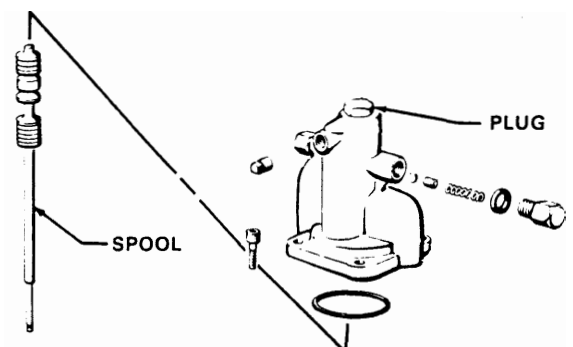

Fig 7

- Periodically, or if electric motor is overheating, unplug unit, follow **Pressure Relief Procedure Warning**, page 10, remove shield and clean all paint, dirt, dust, etc., off the shield, fan blades, motor and cooling fins.

10. To transport the sprayer, empty the wet-cup, or, reduce the level of Throat Seal Liquid (TSL) to 1/3 full or less, and stuff a rag into the wet-cup. Load the sprayer as shown in Fig 8. To avoid leakage of hydraulic fluid, never lay sprayer on its side.

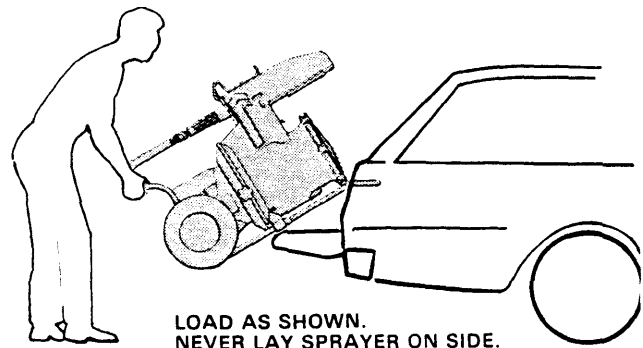

Fig 8

## SERVICE

### WARNING

#### Pressure Relief Procedure

To reduce the risk of serious bodily injury, including fluid injection, splashing in the eyes or on the skin, injury from moving parts or electric shock, always follow this procedure whenever you shut off the sprayer, when checking or servicing any part of the spray system, when installing, cleaning or changing spray tips, and whenever you stop spraying.

1. Engage the gun safety latch.
2. Turn the ON/OFF switch to OFF.
3. Unplug the power supply cord.
4. Disengage the gun safety latch.
5. Hold a metal part of the gun firmly to the side of a grounded metal pail, and trigger the gun to relieve pressure.
6. Engage the gun safety latch.
7. Open the drain valve, having a container ready to catch the drainage.
8. Leave the drain valve open until you are ready to spray again.

*If you suspect the spray tip or hose is completely clogged, or that pressure has not been fully relieved after following the steps above, VERY SLOWLY loosen the tip guard retaining nut or hose end coupling and relieve pressure gradually, then loosen completely. Now clear the tip or hose.*

## TROUBLESHOOTING CHART

PROBLEM	CAUSE	SOLUTION
Electric motor won't run	Hydraulic motor stalled	see page 11, step 8
Electric motor stops while spraying	Unit unplugged or building circuit fuse blown	check, replace
Electric motor runs but paint pump won't work	Defective switch or electric motor	replace
Paint pump runs but output low on up stroke	Overheating switch has opened	unplug unit*
down stroke	Pressure setting too low	increase unit*
both strokes	Outlet filter dirty or plugged	clean
Excessive leakage around hydraulic motor piston rod wiper	Tip plugged	clear; remove and clean;
Paint leaks into wet-cup	Hydraulic fluid low	check, add fluid**
Excessive surge at spray gun	Hydraulic pump worn or damaged	check
Not enough paint breakup	Hydraulic motor worn or damaged	service (see 306-980)
Paint coating too thick	Displacement rod seized by dried paint	service
Tails or fingers in spray pattern	Worn or damaged piston rod or seal	replace (see 306-980)
Spitting from spray gun	Piston ball check not seating	service
Static sparking from spray gun	Piston packings worn or damaged	replace
Gun will not spray	Intake valve ball check not seating	service
	Throat packings worn or damaged	replace
	Spray tip too big or worn	change tip
	Paint supply low or pail empty	fill
	Unit or work not grounded	check, ground
	Large pressure drop in hose	use larger hose
	Drain valve open	close

Check all possible solutions before disassembling any part of your sprayer.

\*The electric motor has overheating protector switch which will automatically reset on cooling. If it opens, unplug unit and let it cool for 2 to 20 minutes. Also try to correct the cause of overheating.

\*\*When adding hydraulic fluid to sump, use only Graco approved fluid. See ACCESSORIES on page 19 for approved fluid.

### WARNING

To reduce the risk of serious bodily injury, including fluid injection, splashing in the eyes or on the skin, injury from moving parts or electric shock, always follow the **Pressure Relief Procedure Warning** on page 12 before servicing.

#### Removing Hydraulic Motor

Remove cotter pin from piston rod. See Fig 9. Unscrew the three tie rod nuts and pull the paint pump down from the rods. This will also pull the hydraulic motor piston down. Rotating the paint pump will usually unscrew the displacement rod from the motor piston; otherwise use wrenches on the flats. Unscrew the three tie rods and remove hydraulic motor from support. At reassembly, be sure that support and motor are absolutely clean.

See 306-980 for hydraulic motor parts and service information.

#### Servicing Pump

Screw extension tube or union off paint pump intake valve, take retaining ring out of tube, remove strainer and put parts in a container of clean solvent. Screw intake valve out of housing and remove the pin, retainer, o-ring, ball and guide. See Fig 9. Put parts in solvent to soak.

Remove the shield and disconnect displacement rod as explained above. Loosen packing nut, push displacement rod down and pull it out through bottom of housing with piston. See Fig 9.

**NOTE:** If displacement rod is seized by dried paint, remove the packing nut, fill packing cavity with solvent and let it soak to free rod.

Screw the piston stud out of displacement rod and remove the ball, packing retainer, glands and packings. See Fig 9. Put parts in solvent to soak. Screw packing nut out of housing and remove throat packings and glands. See Fig 9.

Clean all parts thoroughly with solvent and carefully inspect for damage or wear. Inspect the outer surface of the displacement rod and the inner surface of the insert sleeve in the housing for scratches or scoring which could damage the packings and cause the pump to leak. To check, run a finger over the surface or hold the part up to the light at an angle. If the sleeve needs replacement, contact your Graco representative. The new sleeve must be installed with the tapered end down.

#### Assembling Pump

Repair Kit No. 218-135 (leather packings) and 218-136 (PTFE packings) are available for repacking the pump. For the best results, use all the new parts in the kit, even if the old ones still look good.

All packings must be properly installed. See Fig 9. Notice that the lips of the throat v-packings face down, against pressure, and the lips of the piston v-packings face up, against pressure. Incorrect installation damages the packings and results in the pump leaking.

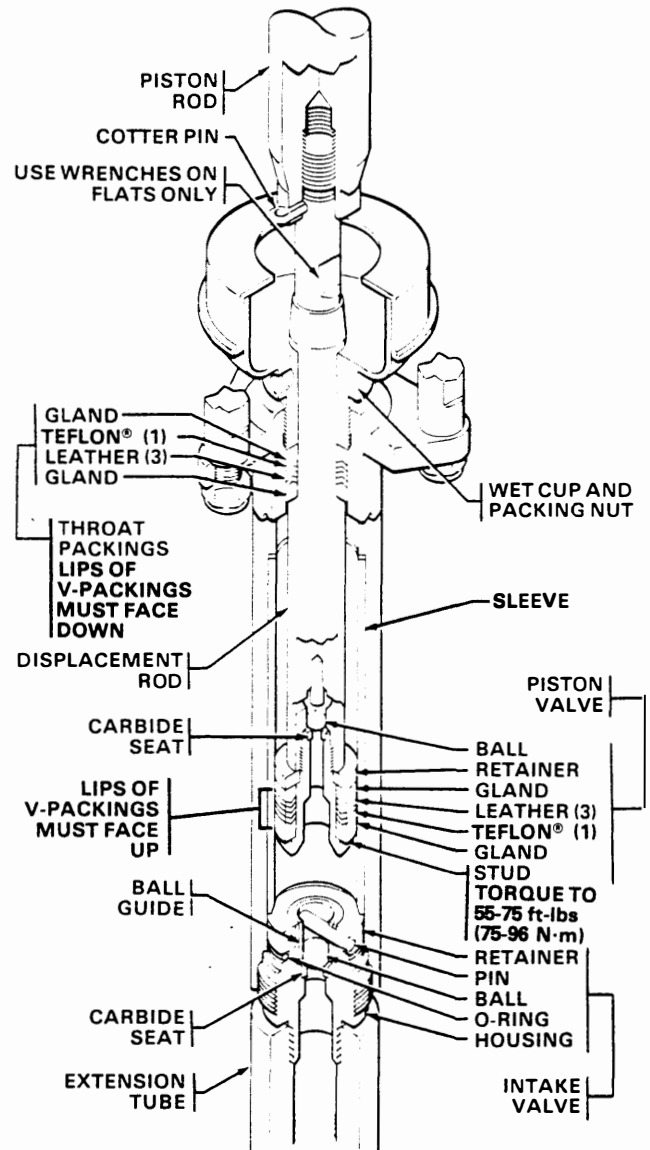

Fig 9

Lubricate displacement rod, packings and sleeve, then reassemble pump using new parts as necessary. If either seat in piston stud or intake valve housing is damaged or worn, replace it with a complete new stud or housing. Tighten piston stud into displacement rod with 55-75 ft-lb (75-96 N·m) of torque. Leave throat packing nut loose until pump is completely assembled, then tighten just enough to prevent leakage—no tighter.

### Replacing Electric Motor

If electric motor won't run and the circuit, on-off switch and fuse are good, follow the **Pressure Relief Procedure Warning** (page 12), disconnect plug from electric outlet and proceed as follows:

Take the shield off. Remove the four screws holding the fan guard to motor and remove the guard. Loosen the fan blade setscrew and pull fan off motor shaft. Take off the junction box cover and disconnect electric cord wires. See Fig 10.

Drive out the two spring pins holding the support mounting and handle to cart frame and pull handle out of frame. See Fig 10. Hook onto the junction box conduit with a hoist, lift the unit about 6 in. (150 mm) off the floor, then pull the cart frame down out of the support mounting and move it out of the way. See Fig 10.

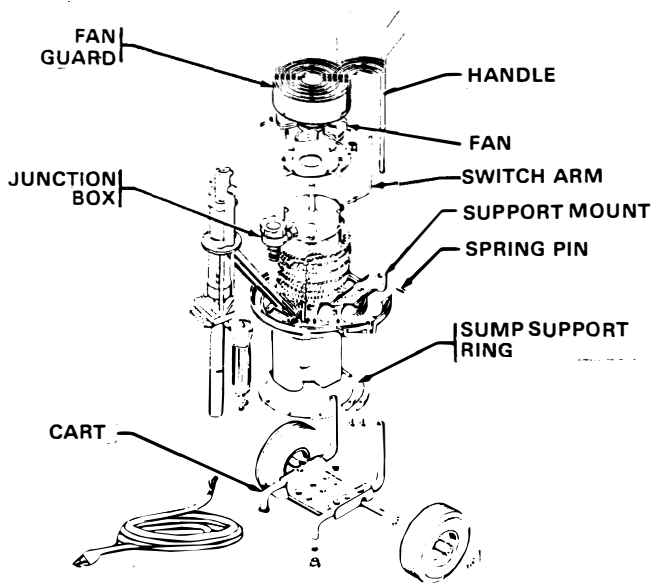

Fig 10

Take out the eight bolts and nuts holding sump mounting, raise unit high enough for sump to clear, then pull sump down off unit and pour out hydraulic fluid. See Fig 10. Carefully lower unit and tilt it back until arms of support mounting are resting on the floor, then put cart handle through arms with bent part up, to support unit. See Fig 11. Hold the hook onto the junction box as you lower unit to be sure it doesn't slip off.

Take out the four electric motor mounting bolts, hold motor by the shaft and junction box, then rock it from side to side to get it loose from support mounting and carefully pull it out of cooling coils. See Fig 11. Screw the box and nipple out of motor, take coupling half off shaft and install parts on new motor. When reassembling nipple, be sure to engage threads at least five full turns. Carefully put the new motor through coils, force it into support mounting and screw the mounting bolts in tightly. See Fig 11. Set the gap between the two coupling halves at 0.31 in. (0.8 mm), then tighten setscrew firmly. See Fig 11.

Clean sump of sediment and reassemble unit using a new sump gasket. Pour hydraulic fluid back into sump through fill hole strainer.

### Replacing Hydraulic Pump

Unplug unit, follow the **Pressure Relief Procedure Warning**, on page 12, take shield off and disassemble unit as explained at left.

Loosen the setscrew in coupling half and push coupling against pump. See Fig 12. Take out the four mounting bolts and washers and remove pump. Discard the o-ring seals.

Remove the adjusting sprocket retaining nut and pull sprocket off adjusting nut.

Apply a light grease to the o-rings and put them in place on pump mounting. Put the coupling half on shaft of new pump and leave it loose. See Fig 12.

Put pump into place on mounting carefully so you don't disturb o-ring seals and screw the mounting bolts in tightly. Push coupling half into other half until there is a 0.31 in. (0.8 mm) clearance between them, then tighten setscrew firmly. See Fig 11. Put the adjusting chain onto sprocket, onto adjusting nut, then screw retaining nut onto stud and tighten, until snug, then back off 1/12 to 1/8 turn.

Clean sump of sediment, reassemble unit and pour hydraulic fluid into sump. Check fluid level and add fluid as needed.

When ordering a replacement hydraulic pump, be very careful to order by the correct part number. To be sure, check the number stamped on the pump.

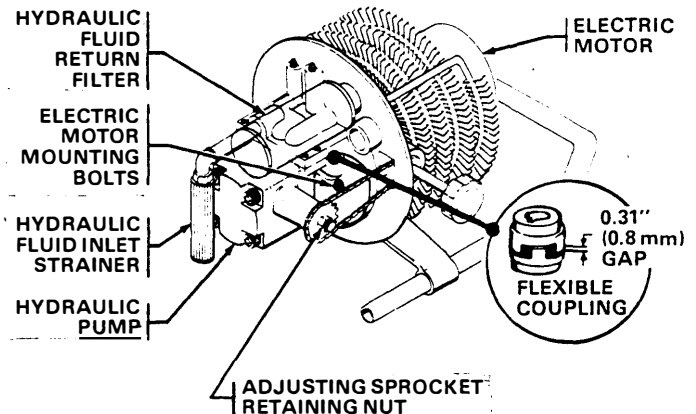

Fig 11

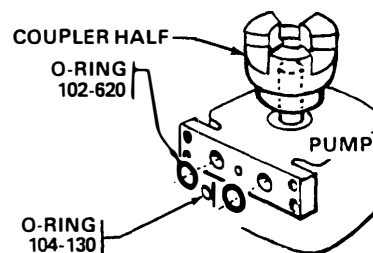

Fig 12

### Electric Motor Wiring Diagram

**NOTE:** The sprayer is wired for 115 volt service. A licensed electrician can rewire it for 230 volt service if necessary.

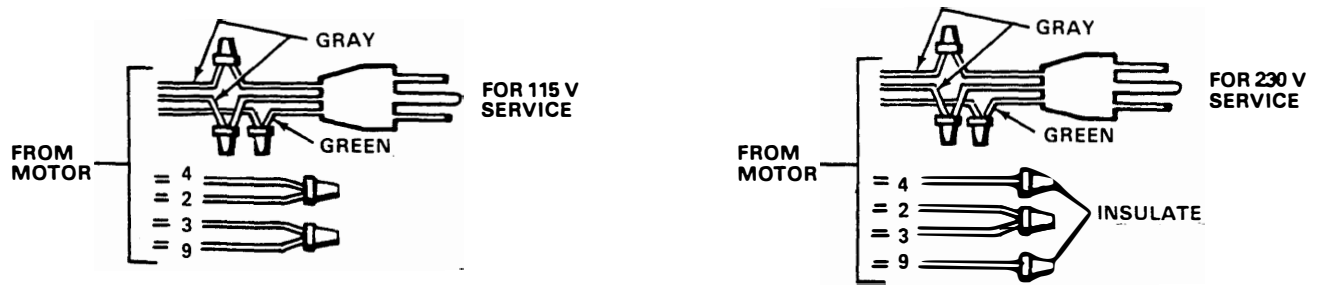
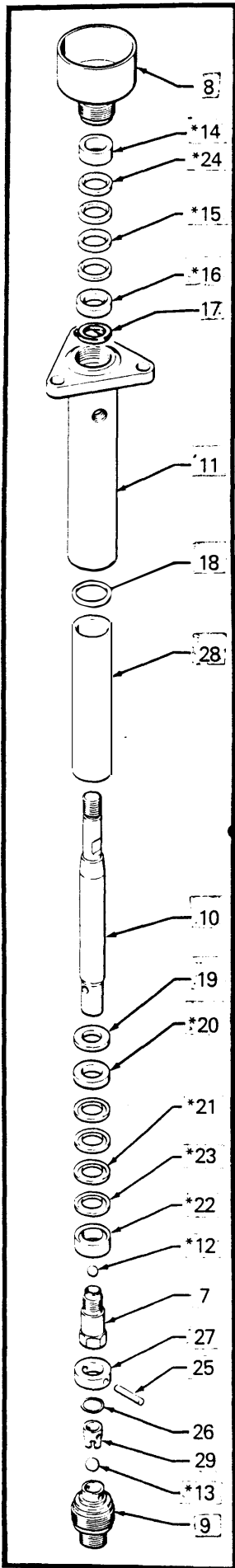

Fig 13



**Model 226-333 with Hose and Gun**  
Includes items 3-128, 142-148

**Model 231-003, Basic Sprayer**  
Includes items 3-128, 142, 144

**Model 226-336 with Hose, Gun, and Suction Tube**  
Includes items 3-148

**Displacement Pump Repair Kit**  
(Must be ordered separately)

**218-135 (with leather packings)**  
Consists of:

Ref No.	Qty
12	1
13	1
14	1
15	3
16	1
19	1
20	1
21	3
22	1
23	1
24	1
26	1
66	1

**218-136 (with PTFE packings)**  
Consists of:

Ref No.	Qty
12	1
13	1
14	1
16	1
20	1
22	1
23	4
24	4

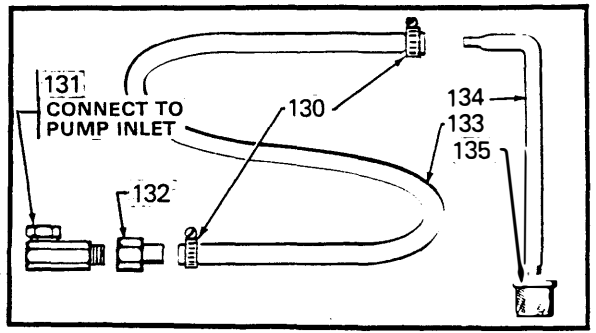

Ref No. 129 5 gal. (19 liter) Suction Tube Assy.

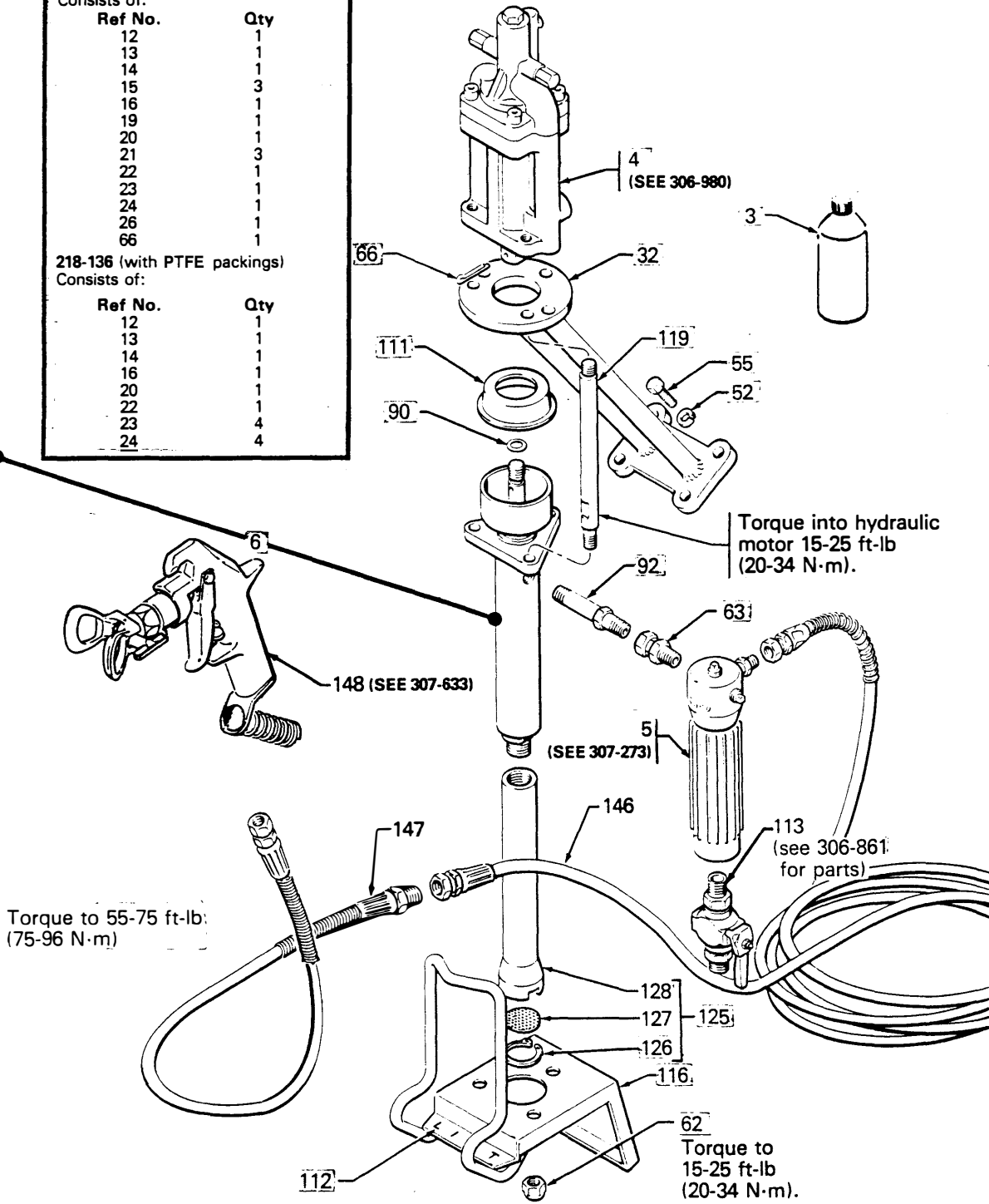



**PARTS DRAWING**

**Ref No. 33 Shield Assy.**  
Includes items 34-40

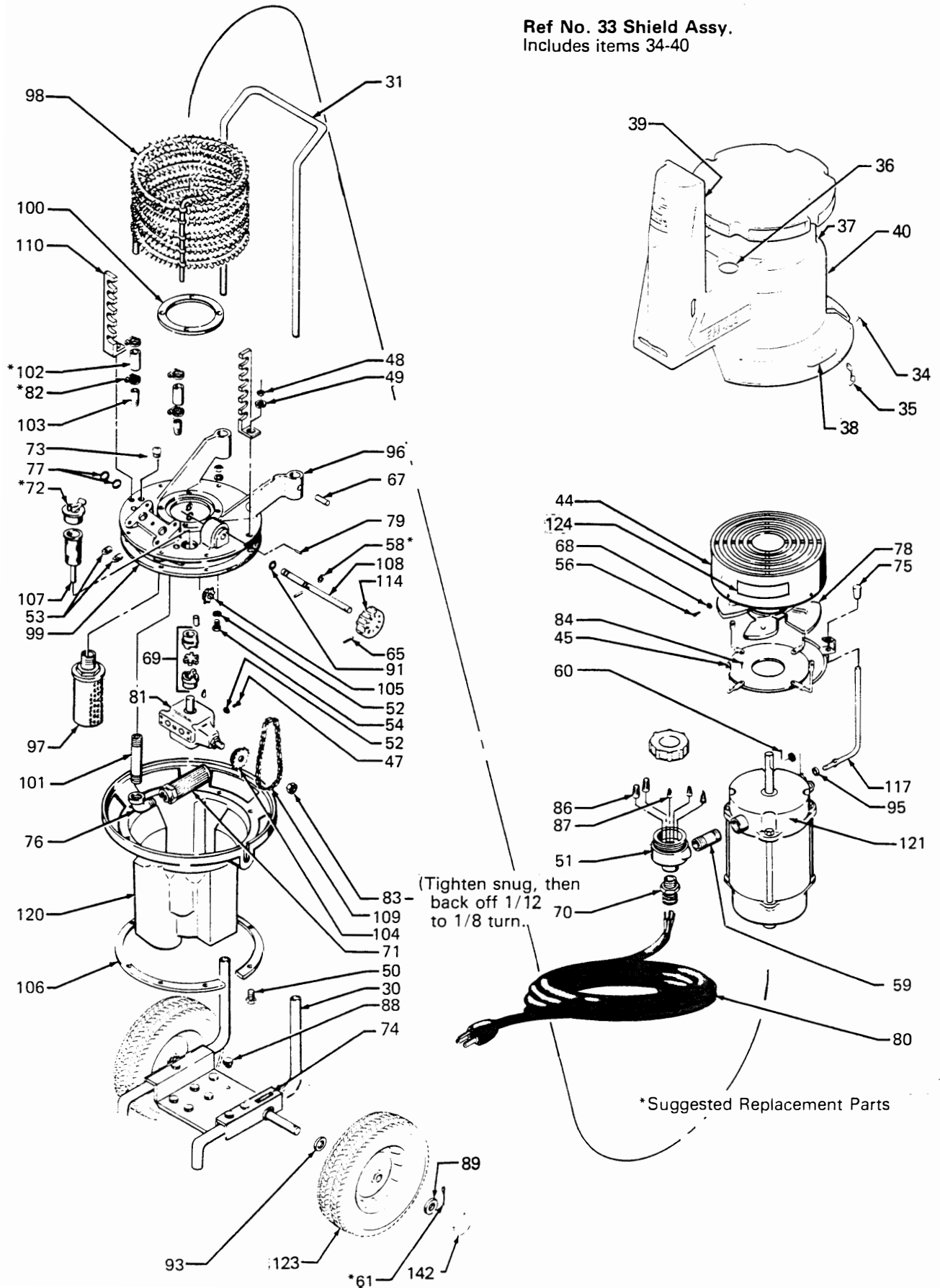

(Tighten snug, then  
back off 1/12  
to 1/8 turn..)

\*Suggested Replacement Parts

**PARTS LIST**

**Model 226-333**  
**EH 333 Hydra-Spray®**  
 Includes items 3-128, 142-148

**Model 226-336**  
**EH 333 Hydra-Spray®**  
 Includes items 3-148

**Model 231-003, Series A**  
**EH 333 Hydra-Spray®**  
 Includes items 3-128, 142, 144

REF NO.	PART NO.	DESCRIPTION	QTY	REF NO.	PART NO.	DESCRIPTION	QTY
3	206-994	THROAT SEAL LIQUID(TSL); 8 oz	1	76	102-617	ELBOW, 90° street	1
4	207-393	HYD. MOTOR, see 306-980 for parts	1	77	102-620	SEAL, o-ring; nitrile rubber	2
5	214-570	OUTLET MANIFOLD & FILTER, see 307-273 for parts	1	78	102-654	FAN	1
6	207-421	DISPLACEMENT PUMP ASSY	1	79	101-154	PIN, cotter	1
	Series C	includes items 7-29	1	80	102-662	CORD, electric; 9 ft. (2.7 m) lg	1
7	205-538	.STUD, piston	1	81	102-812	PUMP, hyd.; 600 PSI (42 bar) max., 4 gpm (15 l/min) max. incl. (1) square key; (2) 102-620 & (1) 104-130 o-ring	1
8	206-269	.NUT, packing; with wet cup	1	82	*103-126	CLAMP, hose; spring type	4
9	206-399	.HOUSING, intake valve	1	83	103-179	LOCKNUT; 5/8-11 thd	1
10	207-084	.ROD, displacement	1	84	105-967	SCREW, type AB self tap; 10-16 x 1/2	4
11	207-420	.HOUSING, displacement pump	1	86	103-711	CONNECTOR, wire; pressure type	3
12	**100-065	.BALL, chrome alloy; 5/16 dia	1	87	103-760	CONNECTOR, wire; pressure type	2
13	**100-084	.BALL, stainless steel; 1/2 dia	1	88	103-867	BUMPER, rubber	9
14	**179-983	.GLAND, female	1	89	154-636	WASHER, flat	6
15	**164-397	.V-PACKING; leather	3	90	154-771	SEAL, o-ring; nitrile rubber	1
16	**179-984	.GLAND, male	1	91	155-685	SEAL, o-ring; nitrile rubber	2
17	164-399	.WASHER, backup	1	92	160-790	NIPPLE, adptr; 3/8 npt(mbe), 3-5/8" lg	1
18	*164-480	.GASKET, PTFE	1	93	176-364	WASHER, flat	2
19	**164-713	.RETAINER, piston packing	1	95	167-187	WASHER, alum.; 1/4"	2
20	**179-987	.GLAND, male	1	96	167-725	MOUNTING, support	1
21	**164-715	.V-PACKING; leather	3	97	*167-748	FILTER, hyd fluid return	1
22	**179-988	.GLAND, female	1	98	167-777	COIL, cooling	1
23	**164-912	.V-PACKING; PTFE	1	99	167-778	GASKET, mounting to sump	1
24	**164-913	.V-PACKING; PTFE	1	100	176-132	GASKET, motor to mounting	1
25	165-049	.PIN, ball stop	1	101	167-780	NIPPLE, pipe; alum.; 3/4 npt; 4" lg	1
26	**165-052	.SEAL, o-ring; PTFE	1	102	*167-781	HOSE, rubber; 3/8 ID, 2-1/4" lg	2
27	165-967	.RETAINER, o-ring	1	103	167-782	ADAPTER, straight	2
28	167-077	.SLEEVE, housing	1	104	167-784	SPROCKET, chain; hyd pump	1
29	170-257	.GUIDE, ball	1	105	167-785	SPROCKET, chain; adj shaft	1
30	214-908	FRAME, cart	1	106	167-789	SUPPORT, sump	2
31	167-801	HANDLE, cart	1	107	167-799	FILTER, fill hole; with gauge rod	1
32	207-797	SUPPORT, motor pump	1	108	167-803	SHAFT, shouldered; valve, adjust.	1
33	214-681	SHIELD, sprayer; includes items 34-40	1	109	167-814	CHAIN, roller	1
34	102-472	.RIVET, blind; 1/8 dia	4	110	167-816	SUPPORT, cooling coil	2
35	167-786	.CLIP, spring tension	2	111	167-817	COVER, plastic snap-on	1
36	104-831	.PLUG	1	112	167-820	LABEL, instruction	1
37	167-809	.LABEL, instruction	1	113	210-659	BALL VALVE, see 306-861 for parts	1
38	170-967	.LABEL, instruction	1	114	167-907	KNOB, valve; adjustment	1
39	176-375	.LABEL, warning	1	116	214-911	PANEL, enclosure; air	1
40	176-115	.SHIELD, bare	1	117	168-235	ARM, switch activator	1
44	208-914	GUARD, fan; top	1	119	168-426	ROD, tie	3
45	208-404	GUARD, fan; bottom	1	120	170-951	SUMP, hyd fluid	1
47	100-004	SCREW, hex hd cap; 3/8-16 x 1 1/4	4	121	169-686	MOTOR, elec.; expl.-prf., 115 volt; UL listed, 60 cycle AC incl.(1) 167-685 3/16 sq key; 1/2" lg, (1) 104-343 switch	1
48	100-015	NUT, hex; 1/4-20 thd	8	123	179-811	WHEEL, semi-pneumatic	2
49	100-016	LOCKWASHER, spring; 1/4"	8	124	171-001	LABEL, instruction	1
50	100-021	SCREW, hex hd cap; 1/4-20 x 1"	8	125	214-904	SUCTION KIT; includes items 126-128	1
51	102-603	BOX, junction	1	126	102-616	RING, retaining; int. type	1
52	100-133	LOCKWASHER, spring; 3/8"	13	127	167-759	STRAINER, sediment	1
53	100-509	PLUG, pipe; 1/4 npt	4	128	176-365	TUBE, extension	1
54	100-659	SCREW, soc hd cap; 3/8-16 x 1"	4	129	208-920	SUCTION TUBE Assy, 5 gal (19 liter) sz (Model 226-336 only) incl. items 130-135	1
55	100-680	SCREW, hex hd cap; 3/8-16 x 7/8"	5	130	101-818	.CLAMP, hose	2
56	100-933	SCREW, type "f" self tap; 8-32 x 3/4"	4	131	160-327	.UNION, 90° SWIVEL: 3/4 npt (mx f)	1
58	*101-166	RING, retaining	2	132	170-705	.ADAPTER, intake	1
59	101-407	NIPPLE, pipe; 3/4 npt, 3" lg	1	133	170-706	.HOSE, 1" ID x 48"; nylon tube	1
60	101-421	PIN, cotter; 1/16 dia., 3/8" lg	1	134	170-957	.TUBE, suction	1
61	*101-545	PIN, cotter; 1/8 dia., 1" lg	2	135	170-959	.STRAINER	1
62	101-566	LOCKNUT, hex; nylon insert, 3/8-16 thd	3	142	104-811	CAP, hub	2
63	155-665	UNION, str. adptr; 3/8 npt (m) x 3/8 npsm (f) swivel	1	144	172-479	TAG, warning (not shown)	1
65	**101-831	PIN, spring; 3/16 dia., 3/4" lg	2	146	210-541	HOSE, paint; nylon static free; 1/4 ID, cpld 1/4 npsm swivel; 50 ft (15.2 m) lg	1
66	101-946	PIN, cotter; 1/8 dia., 1-1/2" lg	1	147	214-701	HOSE, whip end; cpld 1/4 npt(m) x 1/4 npsm(f), 3/16 ID; static free, 36" lg	1
67	*102-039	PIN, spring; 1/4 dia., 1-1/2" lg	2	148	220-956	"FLEX" SPRAY GUN, see 307-633 for parts	1
68	102-063	LOCKWASHER, ext.shkprf; no. 8	4				
69	106-129	COUPLING, flexible	1				
70	102-402	CONNECTOR, elec. cord; water tight; for 1/2 to 5/8 dia. cord	1				
71	102-405	STRAINER, wire cloth; 100 mesh (149 microns) backup, 3/4 npt (f) thd	1				
72	*102-505	PLUG, expander; 1 7/8 dia.	1				
73	104-157	VALVE, vent; hyd. reservoirs	1				
74	102-556	RIVET, blind; 1/8 dia.	2				
75	102-607	TIP, rubber	1				

306 & 307 Numbers in description refer to separate instruction manuals.

\*Recommended "tool box" spare parts. Keep on hand to reduce down time.

\*\*Supplied in repair kit.

See "How To Order Replacement Parts" on page 19.

**ACCESSORIES** (must be purchased separately)

**1 GAL. (3.8 liter) HYDRAULIC FLUID** (approved type)  
207-428

**55-GAL. (200 liter) SUCTION TUBE KIT 207-485**

**PAIL SUPPORT**  
207-490

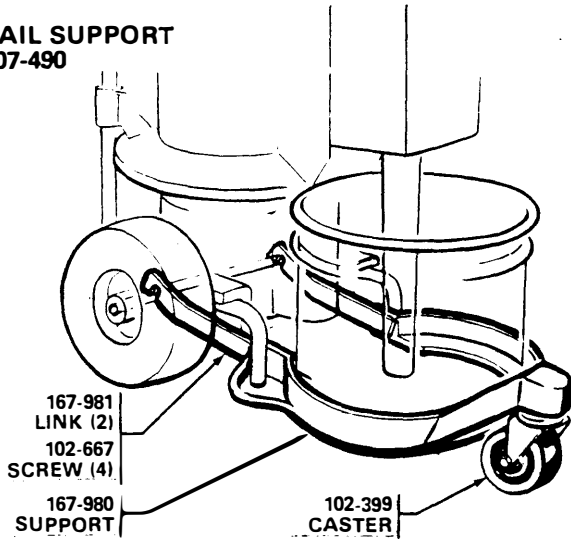

**5000 LB FLUID GAUGE 102-814**

Install to read pressure in hydraulic fluid system.  
**KEEP DIRT OUT OF SYSTEM**

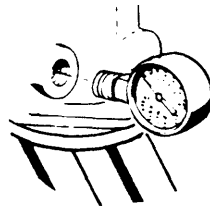

**BALL VALVE (with FKM Seals)**  
210-657

5000 psi (350 bar) MAXIMUM WORKING PRESSURE  
1/4 NPT (MBE)

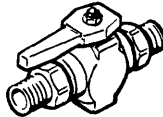

**SELECT-A-FAN (with tips) 206-310**

3000 psi (210 bar) MAXIMUM WORKING PRESSURE  
Fits the fan pattern to both wide and narrow surfaces and clears tips stoppages.



**DIRECTIONAL ADAPTER (less tips) 206-235**

3000 psi (210 bar) MAXIMUM WORKING PRESSURE  
Adjustable 180° swiveling nozzle permits changing the spray pattern direction to satisfy work piece demands.



**DUAL ADAPTER (less tips) 206-236**

3000 psi (210 bar) MAXIMUM WORKING PRESSURE  
Two spray tips controlled by one spray gun—used where one tip does not provide sufficiently wide spray pattern or work piece demands two spray patterns angled in opposite directions.

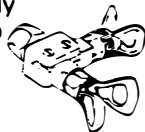

**STATIC FREE FLUID HOSE, Nylon**  
3000 psi (210 bar) MAXIMUM WORKING PRESSURE

Part No.	ID	Length	Thd. Size
214-701	3/16" (4.8 mm)	3 ft (914 mm)	1/4 npt(mxf)
210-540	1/4" (6.4 mm)	26 ft (7.6 m)	1/4 npsm(f)
210-541	1/4" (6.4 mm)	50 ft (15.2 m)	1/4 npsm(f)
214-703	3/8" (9.5 mm)	25 ft (7.6 m)	3/8 npt(m)
214-705	3/8" (9.5 mm)	50 ft (15.2 m)	3/8 npt(m)

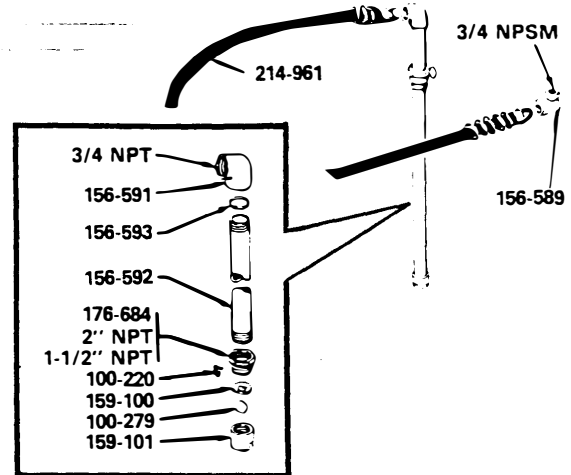

REF NO.	PART NO.	DESCRIPTION	QTY
1	156-593	PACKING, o-ring	1
2	214-961	HOSE, coupled	1
3	100-220	SCREW	1
4	100-279	BALL	1
5	159-100	STOP, ball	1
6	176-684	ADAPTER, bung	1
7	159-101	HOUSING, intake valve	1
8	156-589	UNION, adapter	1
9	156-591	ELBOW, adapter	1
10	156-592	TUBE, riser	1

**GRACO THROAT SEAL LIQUID—TSL**

Non-evaporation solvent for wet-cup.

206-995 1 qt (0.95 liter)

206-996 1 gal (3.8 liter)

**HOW TO ORDER REPLACEMENT PARTS**

- To be sure you receive the correct replacement parts, kit or accessories, always give all of the information requested in the chart below.
- Check the parts list to identify the correct part number; **do not use the ref. no. when ordering.**
- Order all parts from your nearest Graco distributor.

6 digit PART NUMBER	QTY	PART DESCRIPTION

## SERVICE INFORMATION

Listed below by the assembly changed are OLD, NEW, and DELETED parts.

ASSEMBLY PART CHANGED	PART STATUS	REF NO.	PART NO.	NAME
226-333 Sprayer	DELETED	136	216-xxx	Tip
	OLD		218-132	Gun
	NEW	148	220-956	Gun
	DELETED	149	216-001	Kit

ADDED PRODUCT NOTE: Model 226-336 EH 333 Sprayer with suction tube assy. has been reactivated.

INTERCHANGEABILITY NOTE: NEW parts replace OLD parts listed directly above them.

## TECHNICAL DATA

Electric Motor :	1 hp, 1725 rpm, 115/230 V, 60 cycle AC, single phase with automatic reset thermal overload and explosion proof switch, UL listed.
Electric Cord :	No. 12 ga, 3 wire, 10 ft (3 m) long — use at least 12 gauge, 3 wire extension cord.
Hydraulic pump :	4 gpm (15 l/min) max. volume; 600 psi (41 bar) maximum pressure.
Hyd. Fluid Sump :	1 gal. (3.8 l) operating level with fill strainer dipstick.
Hyd. Pump Suction Filter :	100 mesh monel wire cloth with 16 mesh monel wire cloth backup; reusable type.
Hyd. Oil Return Filter :	400 sq. in. (2580 cm <sup>2</sup> ) surface area; 25 micron filtration, disposable type.
Paint Filter :	60 mesh, (12 cm <sup>2</sup> ) stainless steel screen with 3/8 NPT (F) inlet and 1/4 NPT (F) outlets; reusable type.
Paint Pump :	3000 psi (210 bar) max pressure; 3/4 gpm (2.8 l/min) max. output; 100 cycles per gallon; 75 cycles per minute maximum recommended speed for continuous operation.
Wetted Parts :	Nitralloy, Rubber Impregnated Leather, PTFE, Chrome Alloy, Chrome and Zinc Plated Steels, Stainless Steel, Tungsten Carbide Aluminum, Nylon, Polyurethane, FKM
Overall Dimensions :	40''(1000 mm)high, 21''(530 mm) wide, 27 1/2''(600 mm)deep.
Weight :	145 lb (66 kg)
Noise Level :	Does not exceed 85 dBAs (3 ft from machine).
Recommended Port. Generator :	5000 Watt
Electrical Requirements :	115 V, 15 amp circuit

## THE GRACO WARRANTY AND DISCLAIMERS

### WARRANTY

Graco warrants all equipment manufactured by it and bearing its name to be free from defects in material and workmanship on the date of sale by an authorized Graco distributor to the original purchaser for use. As purchaser's sole remedy for breach of this warranty, Graco will, for a period of twelve months from the date of sale, repair or replace any part of the equipment proven defective. This warranty applies only when the equipment is installed, operated and maintained in accordance with Graco's written recommendations.

This warranty does not cover, and Graco shall not be liable for, any malfunction, damage or wear caused by faulty installation, misapplication, abrasion, corrosion, inadequate or improper maintenance, negligence, accident, tampering, or substitution of non-Graco component parts. Nor shall Graco be liable for malfunction, damage or wear caused by the incompatibility with Graco equipment of structures, accessories, equipment or materials not supplied by Graco, or the improper design, manufacture, installation, operation or maintenance of structures, accessories, equipment or materials not supplied by Graco.

This warranty is conditioned upon the prepaid return of the equipment claimed to be defective for examination by Graco to verify the claimed defect. If the claimed defect is verified, Graco will repair or replace free of charge any defective parts. The equipment will be returned to the original purchaser transportation prepaid. If inspection of the equipment does not disclose any defect in material or workmanship, repairs will be made at a reasonable charge, which charges may include the the costs of parts, labor and transportation.

### DISCLAIMERS AND LIMITATIONS

THE TERMS OF THIS WARRANTY CONSTITUTE PURCHASER'S SOLE AND EXCLUSIVE REMEDY AND ARE IN LIEU OF ANY OTHER WARRANTIES (EXPRESS OR IMPLIED), INCLUDING WARRANTY OF MERCHANTABILITY OR WARRANTY OF FITNESS FOR A PARTICULAR PURPOSE, AND OF ANY NON-CONTRACTUAL LIABILITIES, INCLUDING PRODUCT LIABILITIES, BASED ON NEGLIGENCE OR STRICT LIABILITY. EVERY FORM OF LIABILITY FOR DIRECT, SPECIAL OR CONSEQUENTIAL DAMAGES OR LOSS IS EXPRESSLY EXCLUDED AND DENIED. IN NO CASE SHALL GRACO'S LIABILITY EXCEED THE AMOUNT OF THE PURCHASE PRICE. ANY ACTION FOR BREACH OF WARRANTY MUST BE BROUGHT WITHIN TWO (2) YEARS OF THE DATE OF SALE.

### EQUIPMENT NOT COVERED BY GRACO WARRANTY

GRACO MAKES NO WARRANTY, AND DISCLAIMS ALL IMPLIED WARRANTIES OF MERCHANTABILITY AND FITNESS FOR A PARTICULAR PURPOSE, WITH RESPECT TO ACCESSORIES, EQUIPMENT, MATERIALS, OR COMPONENTS SOLD BUT NOT MANUFACTURED BY GRACO. These items sold, but not manufactured by Graco (such as electric motor, switches, hose, etc.), are subject to the warranty, if any, of their manufacturer. Graco will provide purchaser with reasonable assistance in making any claim for breach of these warranties.

**Factory Branches:** Atlanta, Dallas, Detroit, Los Angeles, West Caldwell (N.J.)  
**Subsidiary and Affiliate Companies:** Canada; England; Switzerland; France; Germany; Hong Kong; Japan  
**GRACO INC. P.O. BOX 1441 MINNEAPOLIS, MN 55440-1444**