



METER

AQUALAB® 4



TABLE OF CONTENTS

1. Introduction	1
2. Operation	2
2.1 Installation	2
2.2 Sample Preparation	3
2.2.1 Sample Composition	4
2.2.2 Sample Temperature	6
2.3 Taking a Reading	7
2.4 Viewing Data	9
2.5 Setting Up Isotherm-Determined Moisture Content	10
2.6 Performing a Linear Offset	17
3. System	20
3.1 Specifications	20
3.2 Components	21
3.2.1 Cords and Cables	22
3.2.2 Sample Chamber	22
3.2.3 Buttons	23
3.2.4 Display Screen	24
3.3 Theory	35
3.3.1 Moisture Content	35
3.3.2 Water Activity	35
3.3.3 Chilled-Mirror Dew Point Limitations	38
3.3.4 Water Potential	38

3.3.5 Sorption Isotherms	39
4. Service	40
4.1 Verification and Calibration	40
4.1.1 Water Activity Verification	40
4.1.2 Linear Offset	43
4.1.3 Multipoint Calibration (TEV Only).....	45
4.1.4 Restore Factory Defaults	48
4.2 Cleaning.....	49
4.2.1 Cleaning Kit	50
4.2.2 AQUALAB 4TEV Special Considerations	50
4.2.3 Cleaning Procedure.....	50
4.3 Maintenance Packages	52
4.4 Repair	52
4.5 Troubleshooting.....	53
4.6 Customer Support.....	56
4.7 Terms and Conditions	56
Reference	57
Index	58

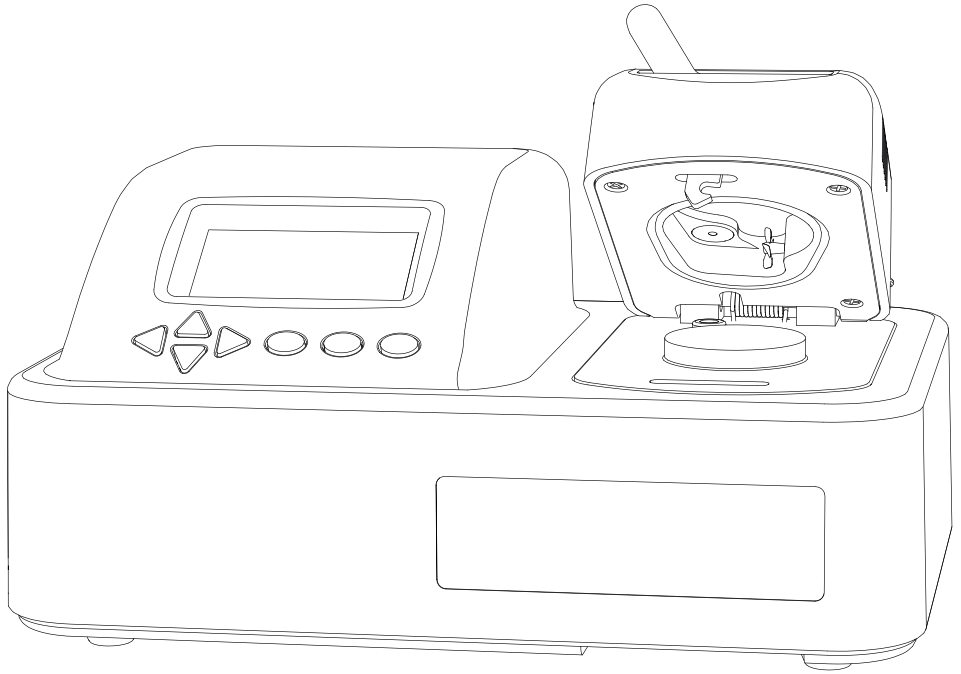

1. INTRODUCTION

Thank you for choosing the AQUALAB® 4 Water Activity Meter from METER Group. AQUALAB is the most accurate and most reliable instrument available for measuring water activity (a_w).

The AQUALAB 4 Series includes two models:

- AQUALAB 4TE uses a chilled-mirror dew point sensor and thermoelectric (Peltier) components to maintain a user-selectable internal temperature.
- AQUALAB 4TEV uses both a chilled-mirror dew point sensor and a capacitance sensor for measuring nonvolatile and volatile substances, respectively. Either sensor is selected using the instrument menu system.

All AQUALAB 4 Water Activity Meters ship with DUO functionality. However, before this feature can be used, a moisture sorption isotherm must be generated for the specific product ([Section 2.5](#)).

This manual includes instructions for setting up, verifying the calibration, preparing samples, taking readings, and maintaining AQUALAB instruments.

Verify all instrument contents shipped and appear in good condition:

- AQUALAB 4 Water Activity Meter
- Calibration certificate
- Power cord
- USB A to B cable
- 250 disposable sample cups
- AQUALAB Cleaning Kit
- Two vials each of the following verification solutions:
 - 0.760 a_w 6.00 mol/kg NaCl
 - 0.500 a_w 8.57 mol/kg LiCl
 - 0.250 a_w 13.41 mol/kg LiCl

2. OPERATION

Please read all instructions before operating the AQUALAB 4 to ensure it performs to its full potential.

Please observe the following considerations carefully.

- Only allow personnel qualified by METER to carry out service work on the electrical components.
- Never remove the cover of the instrument. There are no parts inside the housing that can be serviced or replaced by the user.

NOTE: WARNING: There is a risk of damaging the instrument or of causing serious injury if live components are touched.

- Only operate this instrument with a main power voltage specified (100 to 240 V AC at 50 to 60 Hz).
- Plug the instrument into a grounded outlet or power strip.
- Only use the fuse type and rating specified for this instrument ([Section 3.1](#)).

If the instrument is used in a manner not specified by the manufacturer, the protection provided by the equipment may be impaired.

PRECAUTIONS

METER instruments are built to the highest standards, but misuse or neglect may damage the device and possibly void the manufacturer's warranty. Before using the AQUALAB 4, follow the recommended user instructions and arrange proper protections to safeguard the instrument from damage.

2.1 INSTALLATION

Follow the steps listed in [Table 1](#) to set up the AQUALAB 4.

Table 1 Installation

Preparation	<p>Select Clean, Level Location</p> <p>Select a location where the temperature remains fairly stable to avoid temperature changes that can affect accuracy (away from air conditioner and heater vents, open windows, etc.).</p> <p>Observe clean practices to prevent contamination of the sample chamber.</p> <p>Maintain a level surface to reduce the chance of spilling sample material and contaminating the sample chamber.</p>
--------------------	---

Table 1 Installation (continued)

Installation	Plug In Instrument
	Plug the power cord into the back of the AQUALAB 4 unit and into an outlet.
	Only use the supplied power cord or one rated for AQUALAB 4 and certified for the country of use. The cord must be a minimum of 18 AWG and have a rating for 10 A or greater.
	NOTE: WARNING: An incorrect main power voltage can damage the instrument.
	Turn the Unit ON.
	Allow the AQUALAB 4 a 15-min warm-up period to ensure accurate readings.

2.2 SAMPLE PREPARATION

Proper sample preparation is important to keep the AQUALAB 4 clean and achieve repeatable results. Carefully prepare and load samples to lengthen time between cleanings and help avoid downtime. Be consistent in sample preparation methods (e.g., crush, grind, slice the sample) to obtain reproducible results.

More specific considerations regarding sample composition and sample temperature are discussed in [Section 2.2.1](#) and [Section 2.2.2](#), respectively.

Follow the steps listed below to prepare samples:

1. Make sure the sample to be measured is homogeneous.

Multicomponent samples (e.g., muffins with raisins) or samples that have outside coatings (like deep-fried, breaded foods) can be measured, but they need to have representative portions in the cup and may take longer than other sample types to equilibrate.
2. Place the sample in a disposable sample cup.
 - a. Completely cover the bottom of the cup, if possible, to provide enough sample to get an accurate reading.

The AQUALAB 4 is able to accurately measure a sample that does not (or cannot) cover the bottom of the cup. For example, raisins only need to be placed in the cup and do not need to be flattened to cover the bottom.

A larger sample surface area increases instrument efficiency by providing more stable infrared sample temperatures. It also speeds up the reading by shortening the time needed to reach vapor equilibrium.
 - b. Do not fill the sample cup more than half full.

Overfilled cups can contaminate the chamber and do not make the readings faster or more accurate.
3. Wipe any excess sample material from the rim and outside of the sample cup with a clean KIMWIPES® tissue.

Material left on the rim or the outside of the cup can contaminate the chamber and be transferred to subsequent samples.

4. If a sample cannot be measured immediately, put the disposable sample cup lid on the cup to restrict water transfer.

For longer term storage of no more than 4 h, seal the lid by placing tape or Parafilm® laboratory film completely around the cup to lid junction.

2.2.1 SAMPLE COMPOSITION

The nature of some samples results in longer reading times. These materials may need additional preparation to ensure accurate readings. Contact [Customer Support](#) for questions on sample composition.

Use the following steps to determine if further sample preparation is necessary:

1. Take several readings of the sample to see if the readings (a_w and time) stabilize ([Section 2.3](#)).
2. If the readings take less than 6 min to stabilize, the sample can be handled normally. If the readings take longer than 6 min, remove the sample and take a reading of a verification standard ([Section 4.1.1](#)).
3. If the verification standard takes less than 6 min to test, the sample itself is causing the long read time. Refer to the following sections for pertinent sampling considerations. If the verification standard also takes longer than 6 min to test, the chamber may be dirty and will need to be cleaned ([Section 4.2](#)). Retest the sample after cleaning the chamber.

COATED AND DRIED SAMPLES

Samples with high sugar or fat coatings often require multiple readings, because it equilibrates very slowly with the sample chamber.

Crush or slice the sample before sampling to reduce the time needed to take a water activity reading for coated or dried samples. This increases the surface area of the sample, thus decreasing reading times. However, modifying some samples may alter their water activity readings.

For example, a candy may have a soft chocolate center and a hard outer coating. The water activity reading for the center and the outer coating are different, so one would need to evaluate which part of the sample needed to be measured before crushing it. When the candy is crushed, the water activity represents the average water activity of the entire sample; whereas leaving the candy whole gives a reading for the coating, which may act as a barrier to the center.

To reduce test time when testing whole samples, see [Section](#) to set Low-Emitting mode.

LOW WATER-EMITTING SAMPLES

Some extremely dry, dehydrated, highly viscous, water-in-oil emulsions (e.g., butter), high fat, or glassy compositions may require multiple readings because of their slow water-emitting properties. This is because the slow emission of water decreases the change in water activity sufficiently that the instrument determines the test to be complete, even though changes in water activity are still occurring.

The most effective way to test these types of samples is to run them in the AQUALAB 4 using Continuous or Custom mode and wait for the water activity readings to stabilize.

For faster reading, it is important to have the relative humidity of the chamber at or below the water activity of these types of samples. This causes the sample to release water to the vapor phase and equilibrate with the chamber. If the relative humidity of the headspace is greater than the water activity of the sample, the sample will require a long period of time to reach equilibrium.

To reduce test time when testing low water-emitting samples, see [Section](#) to set Low-Emitting mode.

VOLATILE SAMPLES

Samples with certain volatiles in high enough concentrations may give inaccurate water activity values in the AQUALAB 4TE models. Volatiles condense on the mirror during the reading process but do not evaporate from the mirror as water does. As a result, the reading on samples with volatiles may not be accurate. The concentration of volatiles that causes interference is variable and matrix dependent.

The AQUALAB 4TEV measures volatiles such as propylene glycol and ethanol. The AQUALAB 4TEV contains both a chilled-mirror dew point and a capacitance sensor. The capacitance sensor has a lower accuracy of $\pm 0.015 a_w$, than the dew point sensor, which has an accuracy of $\pm 0.003 a_w$.

To determine if volatiles are a problem, compare dew point readings to capacitance readings. If the dew point readings are $>0.018 a_w$ higher than the capacitance readings, volatiles are likely a problem and the AQUALAB 4TEV or AQUALAB TDL will need to be used for the sample.

After measuring volatiles with the capacitance sensor, clean the chamber ([Section 4.2](#)), place charcoal in the chamber, and seal for a minimum of 5 min before switching to the dew point sensor.

LOW WATER ACTIVITY

A sample's water activity value may be below the cooling capacity of the AQUALAB 4. The AQUALAB 4 will display an error message indicating the lowest reading it attained on that particular sample. The AQUALAB 4 may also give the error message even if the sample is not below $0.03 a_w$. [Section 4.5](#) provides possible solutions to the error message.

If a sample has a water activity of $<0.03 a_w$, a $<$ symbol in the Measurement tab indicates the sample is too dry to be accurately measured by the AQUALAB 4 (Figure 1).



Figure 1 Low water activity reading

If the measured a_w appears lower than the known sample water activity, the instrument sensors may have been contaminated and need to be cleaned or serviced (Section 4.2).

2.2.2 SAMPLE TEMPERATURE

The ambient temperature of the AQUALAB 4 should be between 4 and 50 °C. The AQUALAB 4TE and AQUALAB 4TEV have internal temperature control capabilities that enable them to read samples at temperatures different from the ambient temperature, but no higher than 50 °C and no lower than 15 °C.

Samples that are more than 4 °C colder or warmer than the instrument chamber temperature need to equilibrate to instrument temperature before taking a reading, ideally within 1 or 2 °C of the chamber temperature. Rapid changes in temperature over short periods of time causes the water activity readings to rise or fall until the temperature stabilizes. Proceed with normal measurements when the temperature stabilizes within an optimal 1 or 2 °C of the chamber temperature.

High water activity samples that are warmer than the chamber temperature can cause condensation inside the measuring chamber, which adversely affects subsequent readings. A warning message appears if the sample temperature is more than 4 °C above chamber temperature (Figure 2).

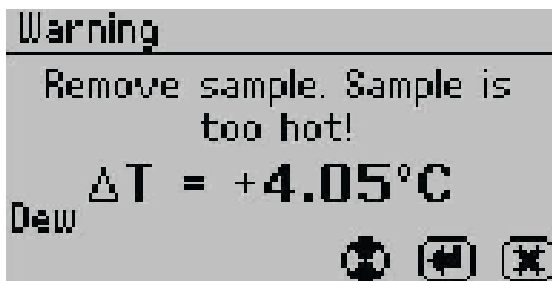

Figure 2 Sample is too hot! message

If this error message appears,

1. Remove the sample from the instrument.
2. Place a lid on the cup.
3. Allow the sample to cool to within 4 °C of the instrument before measuring.

To check the differences in temperature between the sample and the chamber prior to beginning a reading, set the sample in the chamber, close the lid without latching it, and press the **RIGHT** or **LEFT** button. [Figure 3](#) provides an example of this screen.

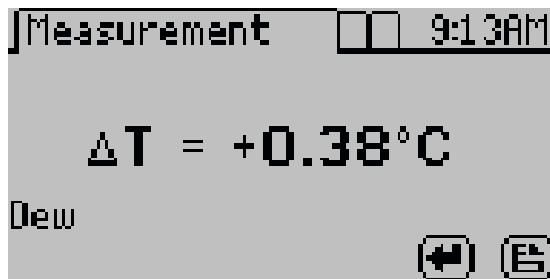

Figure 3 Temperature difference between sample and sample chamber

2.3 TAKING A READING

The AQUALAB 4 provides readings in 5 min or less. Readings are reliable, providing $\pm 0.003 a_w$ accuracy using the dew point sensor.

⚠ CAUTIONS

- Never leave a sample in the AQUALAB 4 after a reading has been taken. The sample may spill and contaminate the instrument chamber if the instrument is accidentally moved or jolted.
- Never move the instrument after a sample has been loaded. Movement may cause the sample material to spill and contaminate the sample chamber.
- Do not measure a sample that has a temperature greater than ± 4 °C than the AQUALAB 4 chamber ([Section 2.2.2](#)). Remove the sample until it is at chamber temperature.

NOTE: NOTE: After measuring volatiles with the capacitance sensor, clean the chamber ([Section 4.2](#)), place charcoal in the chamber, and seal for a minimum of 5 min before switching to the dew point sensor.

Perform the following steps to take a reading.

1. Ensure the AQUALAB 4 is plugged in and turned on.
The splash screen will appear, followed by the main Measurement tab ([Section](#)).
2. Use the **UP** and **DOWN** buttons to scroll through all available product models that may be used ([Figure 4](#)).
The moisture content value adjusts based on the selected model.

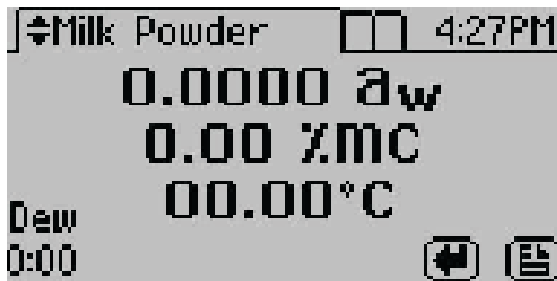

Figure 4 Measurement screen for Milk Powder product model

3. Verify cleanliness (Section 4.2), calibration (Section 4.1), and sample preparation (Section 2.2).

NOTE: The device fan can blow powdery substances; always verify the cleanliness of the sample chamber before reading a new sample.

4. Move the chamber lever to the OPEN position and lift the chamber lid.
5. Check the top lip and outside surfaces of the sample cup to ensure they are free from sample residue and confirm the sample cup is not overfilled.

NOTE: Overfilling the sample cup may contaminate the chamber sensors.

The sample cup lid must be removed for correct functionality.

6. Place the prepared sample cup in the chamber.
7. Close the chamber lid.
8. Move the lever to the READ position to seal the sample chamber. The reading will automatically start.

In 1 to 2 min, the first measurement will display on the screen (this is an intermediate reading). The instrument crosses the dew threshold numerous times to ensure equilibrium and the accuracy of readings. Length of read times may vary depending on temperature differences between the chamber and the sample as well as on other properties of the sample (Section 2.2). The default AQUALAB 4 reading cycle continues until the rates of change of three consecutive intermediate readings are $<0.0005 a_w$ of each other.

When the instrument has finished its read cycle, results will display. The **SAVE** icon replaces the spinning measurement icon, and, if enabled, a series of beeps sounds. The results will include the water activity, read time, temperature, and moisture content for the selected product model (Figure 5).

NOTE: Autosave only saves the moisture content value of the model selected at the end of the reading. Overwrite the autosave by selecting the correct model using the UP and DOWN buttons and selecting SAVE.

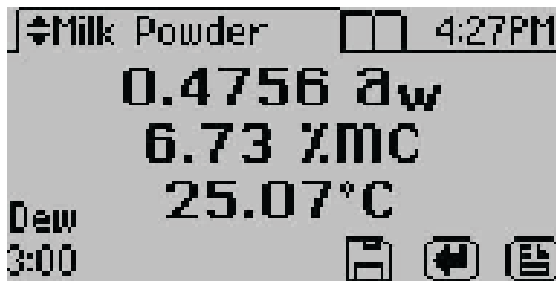

Figure 5 Completed test results with both water activity and moisture content

9. Autosave (default setting) retains the data without any annotation (Section). To add an annotation, select **SAVE**, add desired letters, and select **SAVE** again (Figure 6).



Figure 6 Keyboard screen to annotate data results

2.4 VIEWING DATA

To view prior test results, use the following steps:

1. Press **MENU** to navigate to the Data tab (Figure 7).

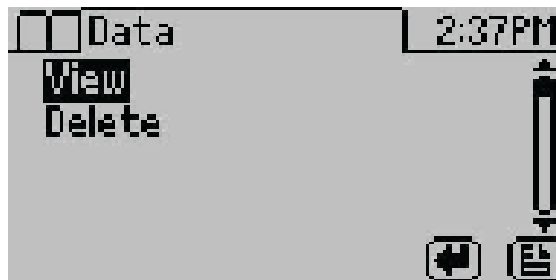

Figure 7 Data tab

2. Select **ENTER**.
3. Scroll through the list of saved tests using **UP** and **DOWN** (to move one item at a time) or **RIGHT** and **LEFT** (to move a page at a time).

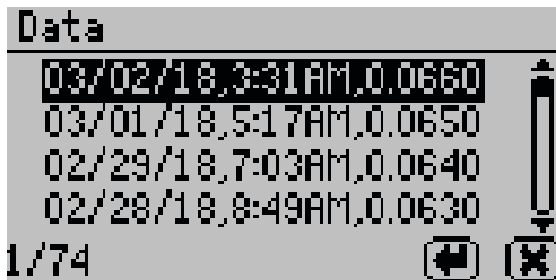

Figure 8 List of saved tests

4. Select **ENTER**.

The detailed test results screen will appear (Figure 9). Tests can also be scrolled through using the arrow buttons on this detailed screen.

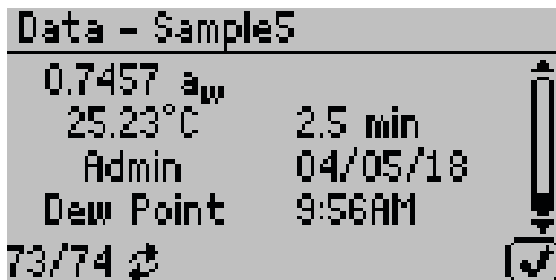

Figure 9 Detailed test results screen

5. Select **OK** to return to the list of tests.
6. Select **CANCEL** to return to the Data tab.

2.5 SETTING UP ISOTHERM-DETERMINED MOISTURE CONTENT

The relationship between water activity and moisture content is called the moisture sorption isotherm. This relationship is specific to the product type and can be modeled to allow water activity measurements to be converted to moisture content. This method provides unmatched precision when compared to traditional moisture measurement methods. All AQUALAB water activity meters can be connected to the cloud-based SKALA platform to unlock this functionality.

An active subscription to SKALA includes access to the METER library of existing isotherm models, allows users to manage all quality data, and enables users to perform advanced analytics. SKALA is compliant with CFR 21 Part 11 and audit ready. For more information, visit metergroup.com/food/skala-system or contact [Customer Support](#).

The AQUALAB 4 calculates moisture content values based on water activity readings using a method known as isotherm-determined moisture content. Isotherm-determined moisture content relies on models stored in the SKALA isotherm library or on a custom isotherm model provided by METER Food Lab.

Because there is no standard for dryness, moisture content results vary between reference methods. These differences are typically linear, and offsetting the model to correlate with the preferred reference method is straightforward. METER recommends offsetting the model to a primary reference method ([Section 2.5](#)).

Once a moisture model is loaded on the AQUALAB 4, it will return a moisture content reading. Until a linear offset has been performed, this moisture content value should not be considered precise and should be discarded ([Section 2.5](#)). This reading is not a reference value that can be used to offset the model.

To assign a model to a product, follow these steps:

1. Open skalacontrol.com.
2. Select Products from the SKALA Main menu to open the Product groups page ([Figure 10](#)).

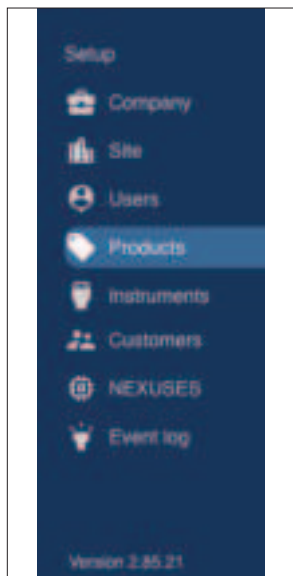

Figure 10 SKALA Main Menu

3. Select the product group that contains the product to be added as a model ([Figure 11](#)).

OPERATION



Figure 11 Select product

4. Select the product.
5. Click the edit icon on the product row (Figure 11).
The Edit Product screen should appear (Figure 12).

Edit product

Product

Name:

Customer:

Package identifier:

Stock size:

Default days active:

Hourly production rate:

Max seconds of downtime:

Cost Per Query:

Product contains residues:

Disable test set readings:

[Add product ingredients](#)

> **PRODUCT DETAILS**

> **CHECKWEIGHT SETTINGS**

> **BROCKHOUSE SETTINGS**

Moisture content model

[Add Model](#)

Figure 12 Edit Product screen

6. Scroll to the Moisture Content Model section of the Edit Product screen (Figure 12).
7. Click on the Add Model link (Figure 13).

OPERATION

The screenshot shows a web-based form titled "Moisture content model". At the top, there is a "Predefined model" dropdown menu. Below it are three dropdown menus: "Market group" (set to "Food stuff"), "Product category" (set to "Dried herbs"), and "Product name" (set to "Peppermint"). There are also input fields for "Linear offset", "Measured AP" (with a value of "10.000"), and "Measured MC" (with a value of "10.000"). A blue "Calculate offset" button is located below the "Measured MC" field. At the bottom of the form, there is a "New Model" button and a "Save" button.

Figure 13 Add Model

A dropdown will appear with two options:

- a. Predefined model from the SKALA isotherm library.

To set up the predefined model, follow [step 8](#).

- b. Custom model using data on the Custom Isotherm Model Coefficients sheet received from the METER Food Lab.

To set up a custom model, follow [step 9](#).

8. METER has created dozens of isotherms and compiled them into the SKALA isotherm library. Contact [Customer Support](#) with questions about the preset isotherm models.
 - a. In the dropdown box below the Moisture Content Model heading, select the Predefined model option ([Figure 14](#)).

Figure 14 Predefined model

- b. Under Market group, select the general classification for the type of model (Figure 15).

The first time the Product is edited, the list of Market groups will be quite long. A maximum of two market groups can be selected and a dialog will appear to confirm the selections. In future sessions, the Market group dropdown will only show the two groups selected in the initial product setup.

NOTE: Once Market groups are selected, they cannot be changed without contacting [Customer Support](#).

Figure 15 Market group

- c. Under Product name, select the product category that most closely matches the product being measured (Figure 16).

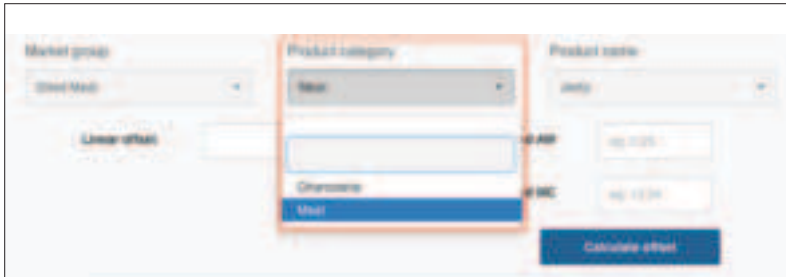

Figure 16 Product category

- d. Click the Save button.
This will save the model associated with the product and close the Edit Product window, returning to the Product groups page.
- e. Before taking moisture content readings, perform a linear offset ([Section 2.6](#)).
- 9. To set up a custom model, the Custom Isotherm Model Coefficients sheet must be received from METER Food Lab. The information on the sheet will be added manually into SKALA. Contact [Customer Support](#) if the sheet was not received.
 - a. In the dropdown box below the Moisture Content Model heading, select the Custom model option ([Figure 17](#)).

There are several isotherm model types. The Custom Isotherm Model Coefficients sheet will identify which type to use.



Figure 17 Custom model selection

- b. Click the radio button beside the model type identified on the Custom Isotherm Model Coefficients sheet ([Figure 18](#)).

NOTE: The DLP (double log polynomial) method is the most frequently used method.

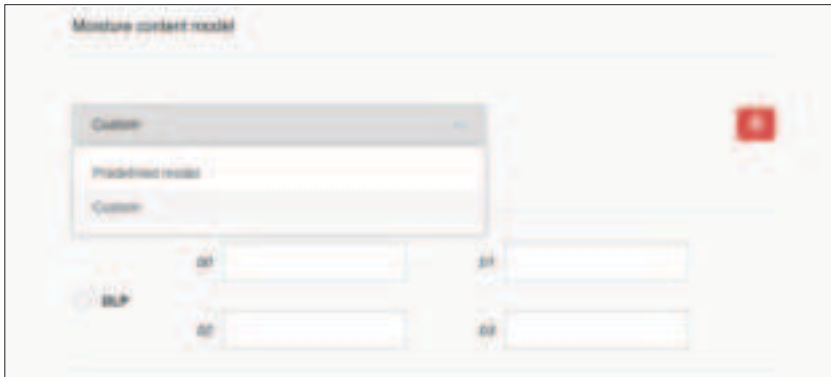

Figure 18 Custom model type and coefficients

- c. Fill in the data fields by matching each field with the values on the Custom Isotherm Model Coefficients sheet.
NOTE: It is extremely important that the radio button remains activated or entered data will be lost.
- d. Click the Save button.
- e. This will save the model associated with the product and close the Edit Product window, returning to the Product groups page.
- f. Before taking moisture content readings, perform a linear offset ([Section 2.6](#)).

2.6 PERFORMING A LINEAR OFFSET

A linear offset must be performed every time a new model is implemented. In addition, the linear offset should be adjusted if moisture content values calculated by the AQUALAB 4 are consistently higher or lower than reference method values over several samples.

To perform a linear offset, select a reference moisture content method to use. Acceptable moisture content reference methods include ROS 1, loss-on-drying, and Karl Fischer titration. Secondary methods have increased margins of error, which will in turn increase the error in AQUALAB 3 moisture content measurements. If desired, an offset can be set to a secondary method (e.g., fast moisture analyzer, microwave analyzer, or NIR) to compare results with a previously used method.

To perform the linear offset, follow these steps:

1. Ensure the instrument is verified ([Section 4.1](#)).
2. Collect a large sample of the product for analysis.
3. Divide the large sample into three subsamples, ensuring that each is representative of the larger sample.
4. Place one subsample into a sample cup.
5. Read the water activity using the AQUALAB 4 ([Section 2.5](#)) and make a note of the water activity value.

OPERATION

This will be used in [step 13](#).

NOTE: The moisture content value has not yet been properly offset and should be ignored.

- Use the reference method to determine the average moisture content of the other two subsamples.

This average is the reference moisture content value. This will be used in [step 14](#).

- Open skalacontrol.com.

NOTE: Linear offsets must be performed on a product-by-product basis in the SKALA Control desktop application. This functionality does not appear in the SKALA Mobile app.

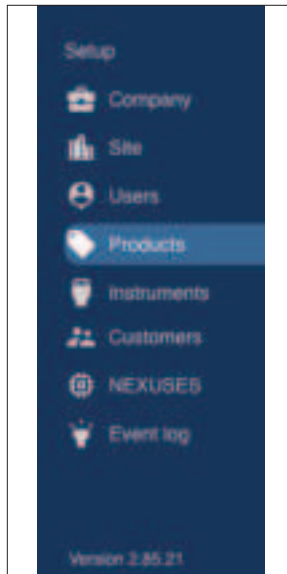

Figure 19 SKALA Main Menu

- Select Products from the SKALA Main menu.
- Select the Product group containing the product to be offset ([Figure 20](#)).

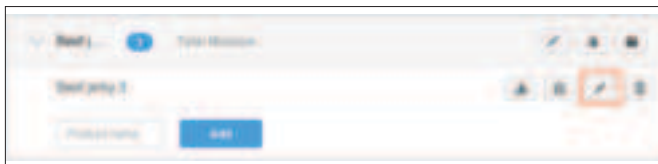

Figure 20 Product group

- Click the edit icon next to the product to be offset ([Figure 20](#)).
- Make sure the model has been selected or set as instructed in ([Section 2.5](#)).
- In the Moisture Content Model portion of the Edit Product screen, scroll down to the Linear offset section ([Figure 21](#)).

The screenshot shows a software interface for setting a linear offset. At the top left, there is a label 'Linear offset' and an empty text input field. To the right, there are two input fields: 'Measured AW' containing the value '40' and 'Measured MC' containing the value '17'. Below these fields is a blue button labeled 'Calculate offset'. In the center of the interface, there is a blue button labeled 'Add Moist'. At the bottom right, there are two buttons: a grey 'Cancel' button and a blue 'Save' button.

Figure 21 Linear offset section

13. Enter the product water activity from [step 5](#) into the Measured AW field.
14. Enter the reference moisture content value from [step 6](#) into the Measured MC field.
15. Do NOT enter a value into the Linear Offset field.
This value will be calculated in SKALA Control from the numbers entered as Measured AW and Measured MC.
16. Click the Calculate offset button.
An offset value will appear in the Linear offset field.
17. Click the Save button.

3. SYSTEM

This section describes the specifications, components, and theory of the AQUALAB 4 instrument.

3.1 SPECIFICATIONS

MEASUREMENT SPECIFICATIONS

Water Activity

Range	0.030–1.000 a_w
Resolution	0.0001 a_w
Accuracy	±0.003 (4TE dew point) ±0.015 (4TEV capacitance)
Repeatability	0.001 a_w

Temperature

Range	15–50 °C
Resolution	0.01 °C
Accuracy	±0.1 °C

Read Time

~5 min

PHYSICAL SPECIFICATIONS

Case Dimensions

Length	26.7 cm (10.5 in)
Width	17.8 cm (7.0 in)
Height	12.7 cm (5.0 in)

Case Material

POLYLAC PA-765 (ABS) with fire retardant

Sample Cup Capacity

14 mL (0.47 fl oz)

Weight

3.1 kg (6.8 lb)

Display

64 × 128 graphical

Operating Temperature

Minimum 4 °C

Typical NA

Maximum 50 °C

Operating Environment

0%–90% noncondensing

Data Communications

USB A and RS-232 serial
9,600–115,000 baud

Power

110–220 VAC
50/60 Hz

COMPLIANCE

Manufactured under ISO 9001:2015

EM ISO/IEC 17050:2010 (CE Mark)

3.2 COMPONENTS

The AQUALAB uses the chilled-mirror dew point technique to measure the water activity of a sample. In an instrument that uses the dew point technique, the sample is equilibrated with the headspace of a sealed chamber that contains a mirror and a means of detecting condensation on the mirror. At equilibrium, the relative humidity of the air in the chamber is the same as the water activity of the sample. The AQUALAB DUO functionality makes it possible to determine both moisture content and water activity with one machine. For information about generating moisture sorption isotherms for the DUO functionality, contact [Customer Support](#).

The AQUALAB 4 main components include the display screen and sample chamber ([Figure 22](#)).

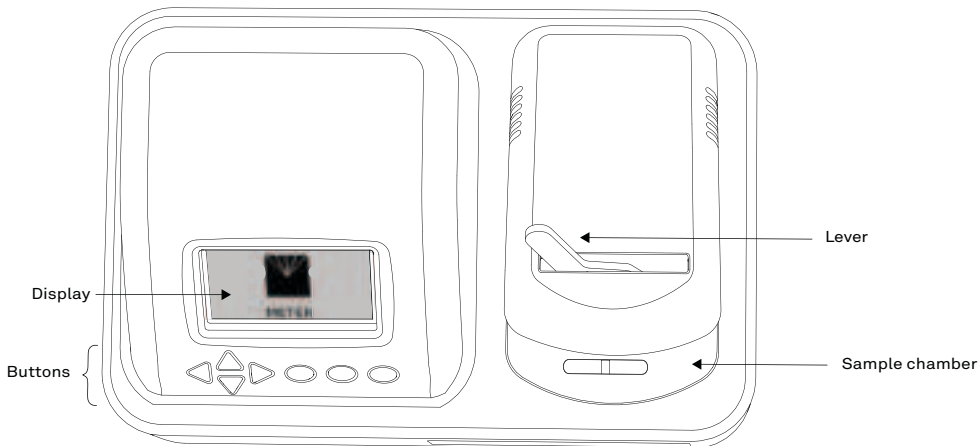

Figure 22 AQUALAB 4 exterior

3.2.1 CORDS AND CABLES

The AQUALAB 4 is shipped with a power cord and a USB cable.

The power cord plugs into the back of the instrument and must be plugged into a grounded outlet or power strip.

NOTE: WARNING: Only use the supplied power cord or one rated for AQUALAB 4 and certified for the country of use. The cord must be a minimum of 18 AWG and have a rating for 10 A or greater.

The USB cable has one USB A connector to connect to a computer and one USB B connector to connect to the AQUALAB 4. The data from the AQUALAB 4 can be saved to the computer with this connection.

AQUALAB 4 may also be connected to a computer using a RS-232 serial cable (not included).

3.2.2 SAMPLE CHAMBER

Externally, the sample chamber lever has two positions: OPEN (handle moved to the right) and READ (handle moved to the left).

Internally, there are two blocks within the sample chamber: an upper lid block and a lower sample block (Figure 23). The blocks are temperature controlled and regulate the temperature of the sample and sample chamber.

The mirror temperature is precisely controlled by a thermoelectric (Peltier) cooler. Detection of the exact point condensation first appears on the mirror is observed with a photoelectric cell. A beam of light is directed onto the mirror and reflected into a photo detector cell. The photo detector senses the change in reflectance when condensation occurs on the mirror. A

thermocouple attached to the mirror then records the temperature at which condensation occurs. The AQUALAB 4 then signals with beeps and displays the final water activity and temperature.

The AQUALAB 4 uses an internal fan to circulate the air within the sample chamber to reduce equilibrium time. Since the AQUALAB 4 measures both dew point and sample surface temperatures simultaneously, it eliminates the need for complete thermal equilibrium, thereby reducing measurement times to <5 min for most samples.

Additionally, the AQUALAB 4TEV uses a capacitance humidity sensor to measure the water activity of a sample. The sensor is suspended in the headspace of the chamber and uses a special polymer material sandwiched between two microporous electrodes to sense humidity changes. The sensor measures a specific capacitance, which is translated by the software and displayed as water activity on the instrument screen. At equilibrium, the relative humidity of the air in the chamber is the same as the water activity of the sample.

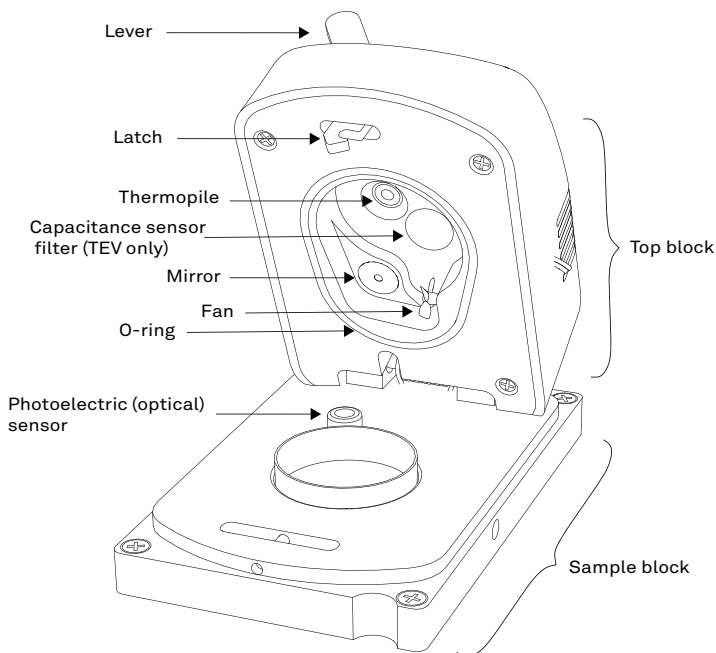

Figure 23 Sample chamber interior

3.2.3 BUTTONS

The power switch is located on the lower left corner of the AQUALAB 4 back panel. After being turned on, the AQUALAB 4 should warm up for 15 minutes before operation to ensure accurate readings.

SYSTEM

There are four arrow buttons: **LEFT**, **RIGHT**, **UP**, and **DOWN** (Figure 24). These buttons allow for navigation through the various screens on the AQUALAB 4. The three round buttons have variable uses, depending on what icon is represented above them on the display (Section 3.2.4).

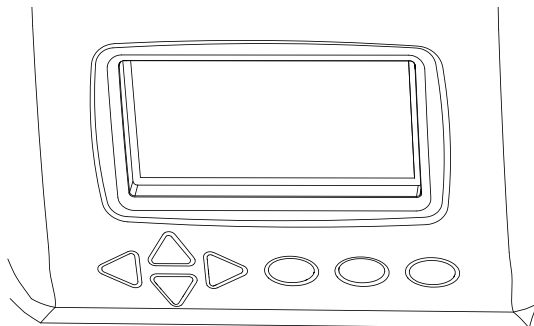

Figure 24 AQUALAB 4 buttons under the display screen

3.2.4 DISPLAY SCREEN

The display screen (Figure 25) has three tabs: Measurement, Configuration, and Data.

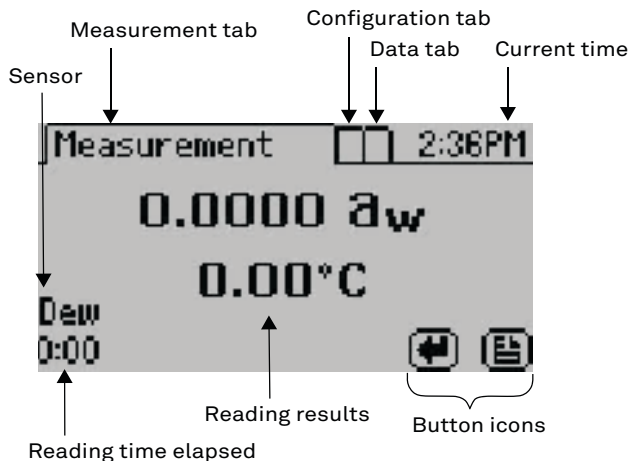









Figure 25 Display screen

The button icons on the display change to show the available actions for the screen ([Table 2](#)).

Table 2 AQUALAB 4 button icons

Icon	Name	Action
	ENTER	Accepts the current action
	CANCEL	Ends the current action
	MENU	Switches between the Measurement, Configuration, and Data tabs
	SAVE	Saves a setting or a reading
	OK	Accepts the input from the user
	AUDIO OFF	Silences beeping
	AUDIO ON	Enables beeping

MEASUREMENT TAB

The Measurement tab ([Figure 26](#)) is the main screen and must be visible to start a reading. Measurement results are displayed on this screen.

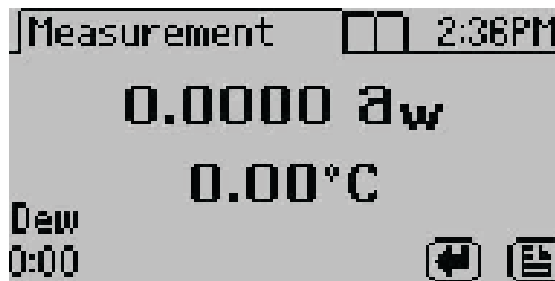

Figure 26 Measurement tab

Using the **RIGHT** or **LEFT** buttons changes the display to a temperature equilibration screen ([Figure 27](#)). This screen shows the temperature difference between the sample and the lid.

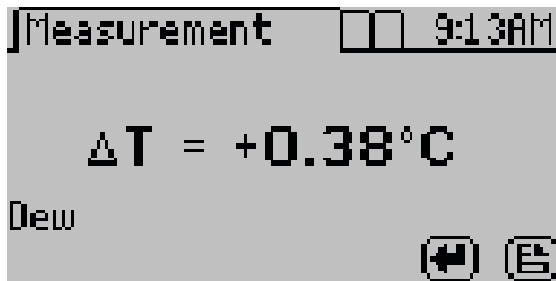

Figure 27 Temperature difference between sample and lid

Using the **UP** or **DOWN** buttons changes the results according to the moisture product isotherms loaded onto the instrument.

The main screen shows the water activity in the middle of the screen and above the sample temperature. The measurement read time is shown at the bottom left of the screen. The AQUALAB 4TEV model will display either DEW or CAP indicating whether the dew point or capacitance sensor is being used.

CONFIGURATION TAB

The Configuration tab provides a menu of configuration options (Figure 28). Use **UP** and **DOWN** to move the selection through the various configuration options or **LEFT** and **RIGHT** to page through the options. Use **ENTER** to select the highlighted option.

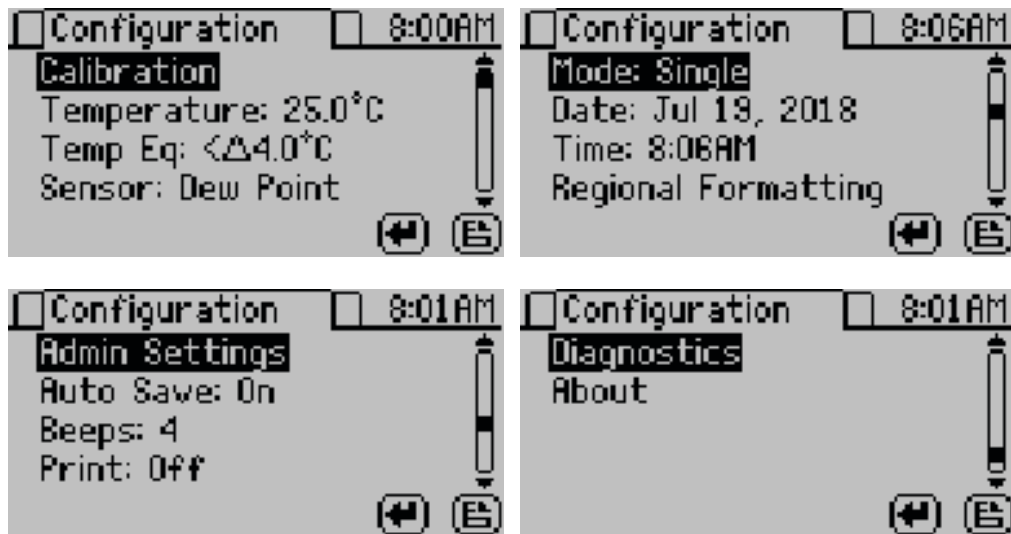

Figure 28 Configuration tab screens

- **Calibration.** Select to start the calibration process (Section 4.1) for water activity or moisture content (Figure 29). Resetting factory defaults is described in Section 4.1.4.



Figure 29 Calibration option

- **Temperature.** Select to set the AQUALAB 4 to the desired temperature using UP and DOWN. When finished, select SAVE (Figure 30).

The AQUALAB 4TE models may be set between 15 and 50 °C in 0.1 °C intervals. The default temperature is 25 °C.

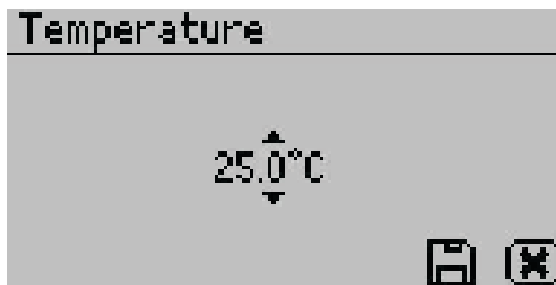

Figure 30 Temperature option

- **Temp Eq.** Select to set the acceptable temperature difference between the sample block and the sample before starting a water activity measurement (Figure 31).

The range is 0.1 to 4.0 °C. A setting of 4.0 °C begins the measurement when the sample is <4.0 °C above or below the block temperature. A setting of 0.1 °C begins the measurement when the sample is <0.1 °C above or below the block temperature.

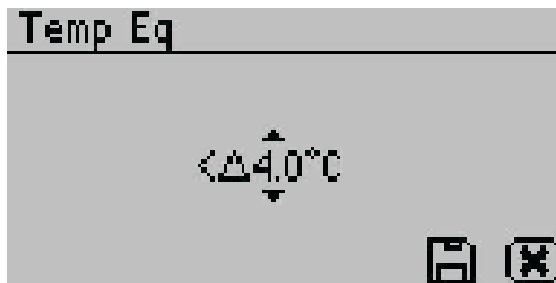

Figure 31 Temp Eq screen

- **Sensor (AQUALAB 4TEV only).** Select to choose a capacitance sensor or chilled-mirror dew point sensor for sampling volatiles or nonvolatiles, respectively. The AQUALAB 4TE model only has a dew point option.
- **Mode.** Select to choose between Single, Continuous, ISO 18787, Custom, or Low-Emitting mode (Figure 32). The current mode settings appear at the top of the screen with the number of tests appearing first, followed by the stability value (Δa_w).

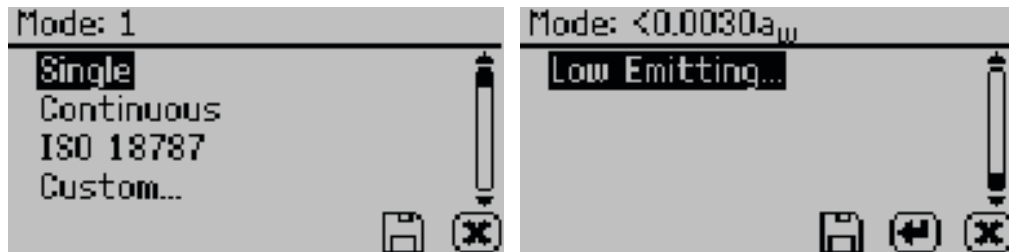

Figure 32 Custom mode options

- ♦ Single mode reads the sample once.
- ♦ Continuous mode reads the sample until the chamber lid is opened or the test is stopped by selecting **CANCEL**.
The AQUALAB 4 reads the sample, displays results, and begins another read cycle without further action from the user. The machine signals the completion of each reading with a beep. A timer on the screen tracks the cumulative read time. All readings taken during Continuous mode are saved on the instrument memory if the autosave feature is turned on (default).
- ♦ ISO 18787 mode reads the sample until the water activity change is equal to or less than 0.0003 a_w per minute.
- ♦ Custom mode reads a sample multiple times until a set level of stability is achieved. For example, the instrument could be set to read the sample until two consecutive tests are within $\pm 0.001 a_w$ of each other.

Use **RIGHT** and **LEFT** to change between the Readings or Δa_w settings.

Use **UP** and **DOWN** to change to select the number of readings (2 to 9).

Use **UP** and **DOWN** to select the Δa_w value (any number from 0.0005 to 0.0200) (Figure 33).

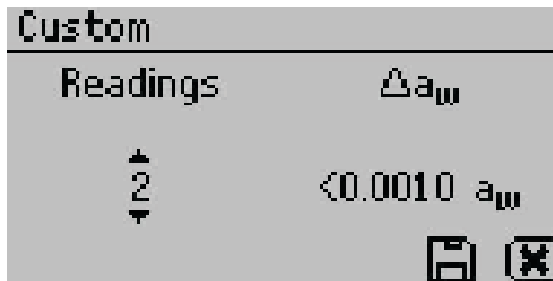

Figure 33 Custom mode screen

Select **SAVE** to update and exit. Select **CANCEL** to exit without updating. The Mode screen reappears with the updated custom settings at the top of the screen.

If autosave is turned on (default), all test readings will save to the instrument memory, but only the final reading will remain on the Measurement screen.

- ♦ Low-Emitting mode gives the option of speeding up test time by adjusting the equilibrium trigger value (Figure 34).

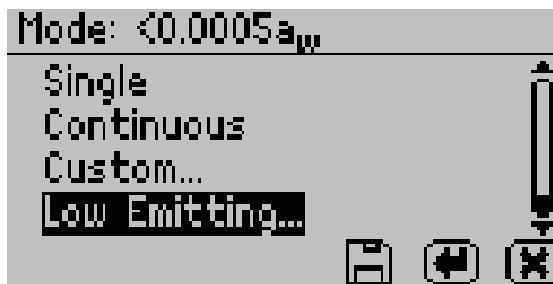

Figure 34 Low-Emitting mode screen

AQUALAB 4 determines vapor equilibrium at the end of a test by comparing sequential water activity values, looking for a trigger value difference $<0.0005 a_w$. This value can be adjusted to any value between 0.0003 and $0.0030 a_w$. Increasing the trigger value causes a subsequent reduction in instrument accuracy and precision but results in a shorter test time. This mode is for samples that are slow to equilibrate, such as vegetable oils, high-fat samples, and high-viscosity samples. In these types of cases, the loss in performance may be acceptable in order to speed up the analysis time. Use a high trigger value only after careful consideration of the impact on test results.

NOTE: The computation for Low-Emitting mode has changed between AQUALAB 4 firmware version 2 and version 3. To compare low emitting measurements across instruments with different versions, set low emitting value in version 3 and newer to twice the value of the low emitting setting in version 2.

- **Date.** Select to set the date in the instrument. Use **RIGHT** and **LEFT** to change between the month, day, and year categories and **UP** and **DOWN** to change the individual values (Figure 35).

The date is recorded with each water activity reading.



Figure 35 Date option

- **Time.** Select to set the time in the instrument. Use **RIGHT** and **LEFT** to change between the hour and minute categories and **UP** and **DOWN** to change the individual values (Figure 36). The hour setting automatically changes between AM and PM. The time is recorded with each water activity reading.



Figure 36 Time option

- **Regional Formatting.** Select to configure how the AQUALAB 4 displays information. Choose the temperature scale (Celsius or Fahrenheit), the date display (mm/dd/yy or dd/mm/yy), the hour format (12h or 24h), and the language (Figure 37).

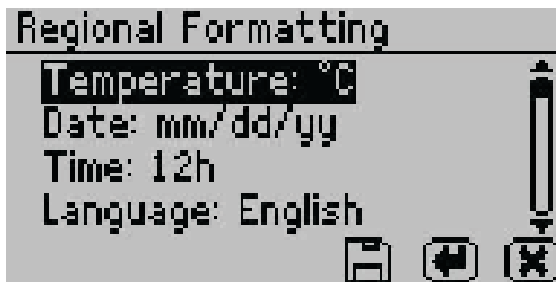

Figure 37 Regional Formatting option

- **Admin Settings.** Select to create an administrator password as well as create, edit, and delete additional users (Figure 38).

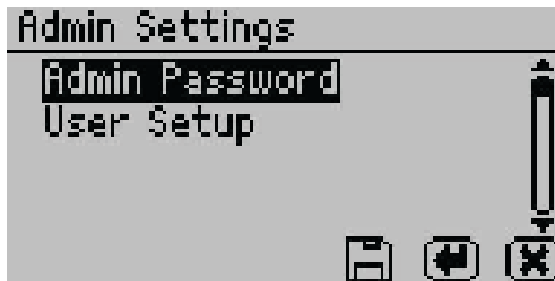

Figure 38 Admin Settings option

The Admin Settings allow the administrator to grant or block access to some or all the configuration options.

NOTE: Once the administrator is set up, the password cannot be recovered. The AQUALAB 4 must be sent back to METER to be reset.

Administrators can add, edit, or delete users from the User Setup screen. The keyboard allows for lowercase, uppercase, and accented letters (Figure 39).



Figure 39 Keyboard screen

NOTE: User setup is not required for instrument operation. It is for users requiring 21 CFR Part 11 compliance or who want to save specific settings.

Once the administrator and users are set up, an Access option will appear on individual user screens (Figure 40).



Figure 40 Access option on a user screen

To lock out users from accessing certain settings, enter the Access function and use **UP** and **DOWN** to find the desired option. Selecting the option will toggle it ON or OFF: calibration, temperature, temperature equilibration, sensor selection, mode, date/time, region, password, autosave, number of beeps, and delete (Figure 41). These options can also be all locked or unlocked at the same time.



Figure 41 Access settings first screen

- **Autosave.** Select to turn Autosave on or off. Autosave stores water activity readings within the instrument automatically for every water activity reading in the internal memory. The AQUALAB 4 can store up to 8,000 records before the memory is full.

Any individual reading may be saved manually right after completing the test and before beginning the next test, regardless of the Autosave setting.

NOTE: If a reading is autosaved, it is not possible to give it an annotation later.

- **Beeps.** Select to change the number of notification beeps for a finished test (four, continuous, or no beeps). The audible notification can also be turned off.
- **Print Mode.** Select to change the information printed out over the serial port to one of the following options:
 - ♦ **Off:** Turns off printing out the serial port after a reading has completed. Ideal for use with SKALA Hub systems.
 - ♦ **On:** Turns on basic printing after a reading is completed. Reports reading duration (in minutes), sample temperature (in Celsius), and water activity.
 - ♦ **Detailed:** Turns on detailed printing after a reading is completed including the date (dd-mm-yy), 24-h time (HH:MM), instrument serial number, reading duration (in minutes), sample temperature (in Celsius), and water activity.

NOTE: When a Brecknell printer is connected, setting the print mode to On will keep the printer time synchronized with the AQUALAB 4. Setting the print mode to Detailed will disable the printer date and time header and instead use the time directly from the AQUALAB 4 instrument.

- **Diagnostics.** Select to view information regarding pertinent sensors (Figure 42). For the chilled-mirror dew point sensor, the Diagnostics option provides lid, base, sample and mirror temperatures, optical voltage, and the user offset. Figure 42 shows typical values for the sensors.

Diagnostics			Diagnostics		
Lid:	25.50°C	↑ ↓ ✓	Offset:	+0.0002 a _w	↑ ↓ ✓
Base:	25.19°C				
Sample:	25.23°C				
Mirror:	26.92°C				
Optical:	1.745mV				

Figure 42 Chilled-mirror dew point sensor Diagnostics screen

For the capacitance sensor (TEV models only), Diagnostics provides lid, base, and sample temperatures, relative humidity, and the capacitive sensor user offset (Figure 43).

Diagnostics		$\Delta=0.40^{\circ}\text{C}$
Lid:	25.40°C	
Base:	25.09°C	
Sample:	25.12°C	
RH:	22.9% (20562)	
Offset:	+0.000 a _w	✓

Figure 43 Capacitance sensor Diagnostics screen

- **%Moisture.** Select to view all isotherm models on the instrument (Section 2.5).
- **About.** Select to view instrument information including the serial number and firmware code version of the instrument (Figure 44).

About
SN: AL400002634
Lid SN: ALB00002123
Version: AS4 3.00.11
©2018 METER Group
✓

Figure 44 About screen

DATA TAB

Data can be viewed or deleted from the Data tab (Figure 45).

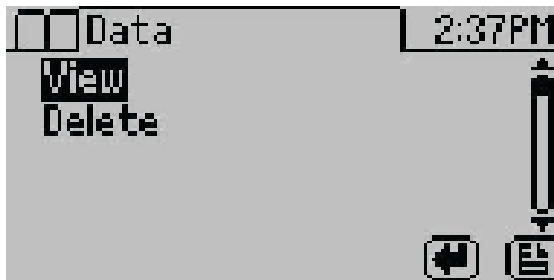

Figure 45 Data tab

- **View.** Select to view stored measurements with the most recent measurements at the top of the table (Figure 46). Use **UP** and **DOWN** to move through the stored data. Use **LEFT** and **RIGHT** to page quickly through the data.

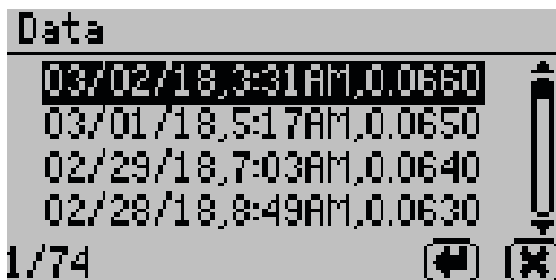

Figure 46 View data

Select a highlighted reading to view detailed information (Figure 47).

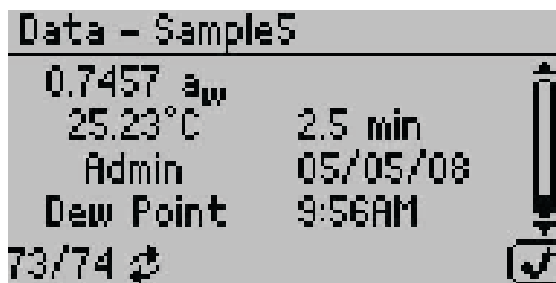

Figure 47 Data sample detail screen

The screen displays the name of the reading (if annotated), the water activity of the sample, the temperature of the sample, the test time, the user who ran the test (if set up), the reading date, the sensor used, the time the reading was taken, and the sequence number of the stored reading. Use **UP** and **DOWN** to scroll through readings.

- **Delete.** Select this option to delete **all** data currently stored in the instrument. Readings cannot be deleted individually. If the information has not been backed up, a reminder will appear (Figure 48).

NOTE: Deleted data cannot be recovered.

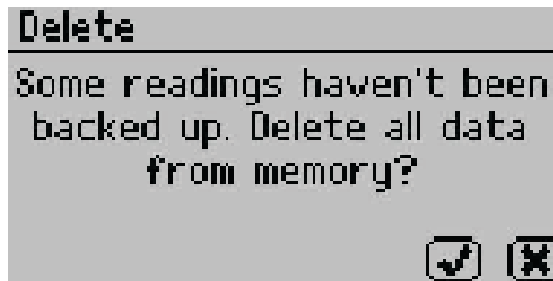

Figure 48 Delete option backup reminder dialog

3.3 THEORY

Water is a major component of foods, pharmaceuticals, and cosmetics and influences the product texture, appearance, flavor, and shelf life. Quantifying these attributes require two basic types of water analysis: moisture content and water activity (a_w).

3.3.1 MOISTURE CONTENT

Moisture content implies a quantitative analysis to determine the total amount of water present in a sample. There are two primary methods for determining moisture content: loss on drying and Karl Fisher titration. Secondary methods, such as near infrared (NIR) and nuclear magnetic resonance (NMR), may also be used. Moisture content determination is essential in meeting product nutritional labeling regulations, specifying recipes, and monitoring processes.

However, moisture content alone is not a reliable indicator for predicting microbial responses and chemical reactions in materials. The limitations of moisture content measurement are attributed to differences in the intensity that water associates with other components.

3.3.2 WATER ACTIVITY

Water activity (a_w) is a measurement of the energy status of the water in a system. The value indicates how tightly water is bound, structurally or chemically, within a substance. The lower a sample's water activity, the more tightly bound that water is within the sample. The concept of water activity is of particular importance in determining product quality and safety. It predicts safety and stability with respect to microbial growth, chemical and biochemical reaction rates, and physical properties.

Water activity is a measure of the energy status of the water in a system and is a far better indicator of product stability than moisture content. [Figure 49](#) shows how the relative activity of microorganisms, lipids, and enzymes relate to water activity. While other factors, such as nutrient availability and temperature, can affect the relationships, water activity is the best single measure of how water affects these processes.

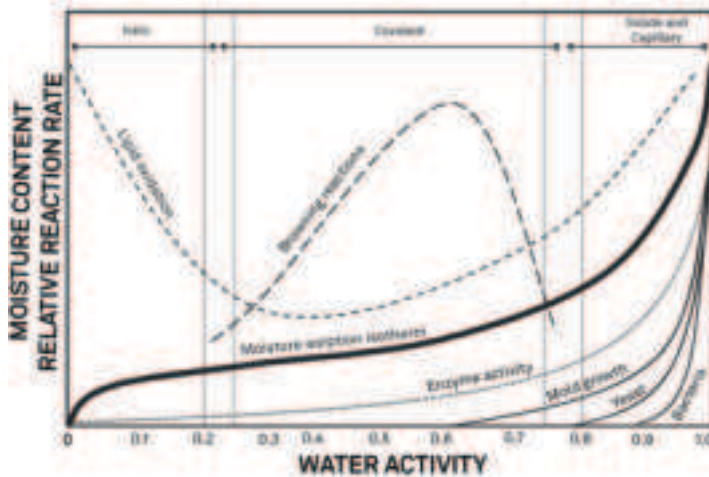

Figure 49 Water activity diagram adapted from Labuza (1976)

Researchers measure the water activity of a system by equilibrating the liquid phase water in the sample with the vapor phase water in the headspace and measuring the relative humidity of the headspace. In the AQUALAB 4, a sample in a sample cup is sealed inside the sample chamber, which contains a fan, a dew point sensor, and an infrared thermometer. The fan speeds equilibrium and controls the boundary layer conductance of the dew point sensor. The dew point sensor measures the dew point temperature of the air in the chamber, and the infrared thermometer measures the sample temperature. From these measurements, the relative humidity of the headspace is computed as the ratio of the dew point temperature saturation vapor pressure to the saturation vapor pressure at the sample temperature. When the water activity of the sample and the relative humidity of the air are in equilibrium, the measurement of the headspace humidity gives the water activity of the sample. Water activity is the relative humidity of air in equilibrium with a sample in a sealed chamber.

In addition to equilibrium between the liquid phase water and the vapor phase, the internal equilibrium of the sample is important. If a system is not at internal equilibrium, one might measure a steady vapor pressure (over the period of measurement) which is not the true water activity of the system. An example of this might be a baked good or a multicomponent food. Initially out of the oven, a baked good is not at internal equilibrium; the outer surface is at a lower water activity than the center of the baked good. One must wait a period of time in order for the water to migrate and the system to come to internal equilibrium. It is important to keep in mind that by this definition, water activity is an equilibrium measurement.

The water activity of a sample is influenced by factors that affect the binding of water. These factors include temperature, osmotic, matric, and pressure effects. Typically, water activity is measured at atmospheric pressure, so only the osmotic, temperature, and matric effects are important.

TEMPERATURE EFFECTS

Temperature plays a critical role in water activity determination. Most critical is the measurement of the difference between sample and dew point temperature. For water activity measurements to be accurate to 0.001, temperature difference measurements need to be accurate to 0.017 °C. The AQUALAB 4 infrared thermometer measures the difference in temperature between the sample surface and the sample block. The thermometer is carefully calibrated to minimize temperature errors; however, achieving 0.017 °C accuracy is difficult when temperature differences are large. Most accurate measurements are obtained when the sample is near sample chamber temperature.

Another effect of temperature on water activity occurs when samples are near saturation. A sample that is close to 1.0 a_w and is warmer than the sensor block will cause water to condense within the chamber. This causes errors in the measurement and in subsequent measurements until the condensation disappears. For example, a sample at 0.75 a_w only needs to be 4 °C above the sample chamber temperature to cause condensation to form. The AQUALAB 4 warns the user if a sample temperature is more than 4 °C above the chamber temperature, but for high water activity samples, the operator needs to be aware that condensation can occur if a sample is warmer than the sample block.

There are several advantages in having a temperature-controlled water activity meter. A few major reasons are detailed here.

1. Research purposes.

Researchers can use temperature control to study the effects of temperature on the water activity of a sample, make a comparison of the water activity of different samples independent of temperature, and conduct accelerated shelf-life studies or other water activity studies where temperature control is critical. There are many shelf-life, packaging, and isotherm studies in which temperature control would be very beneficial.

2. Compliance with government or internal regulations for specific products.

Though the water activity of most products varies by less than ± 0.02 per degree Celsius, some regulations require measurement at a specific temperature. The most common specification is 25 °C, though 20 °C is sometimes indicated.

3. Minimization of extreme ambient temperature fluctuations.

If the environmental and AQUALAB 4 temperatures fluctuate by as much as ± 5 °C daily, water activity readings may vary by $\pm 0.01 a_w$. Temperature control eliminates variations caused by changes in ambient conditions.

The AQUALAB 4TE models have thermoelectric components installed to allow the instrument to maintain a set chamber temperature. Customers can set the temperature using the Configuration tab.

OSMOTIC EFFECTS

Osmotic effects are well known from biology and physical chemistry. Water is diluted when a solute is added. If this diluted water is separated from pure water by a semipermeable membrane, water tends to move from the pure water side through the membrane to the

side with the added solute. If sufficient pressure is applied to the solute-water mixture to just stop the flow, this pressure is a measure of the osmotic potential of the solution. Addition of 1 mol of an ideal solute to 1 kg of water produces an osmotic pressure of 22.4 atm. This lowers the water activity of the solution from 1.0 to 0.98 a_w . For a given amount of solute, increasing the moisture content of the systems dilutes the solute, decreasing the osmotic pressure, and increasing the water activity. Since microbial cells are high concentrations of solute surrounded by semipermeable membranes, the osmotic effect on the free energy of the water is important for determining microbial water relations and therefore microbe activity.

MATRIX EFFECTS

The sample matrix affects water activity by physically binding water within its structure through adhesive and cohesive forces that hold water in pores and capillaries and to particle surfaces. If cellulose or protein were added to water, the energy status of the water would be reduced. Work would need to be done to extract the water from this matrix. This reduction in energy status of the water is not osmotic, because the cellulose or protein concentrations are far too low to produce any significant dilution of water. The reduction in energy is the result of direct physical binding of water to the cellulose or protein matrix by hydrogen bonding and van der Waals forces. At higher water activity levels, capillary forces and surface tension can also play a role.

3.3.3 CHILLED-MIRROR DEW POINT LIMITATIONS

The limitation of the AQUALAB 4TE is its ability to accurately measure samples with high concentrations (typically >1%) of certain volatile compounds such as ethanol or propylene glycol, which can condense on the surface of the chilled mirror. The extent of the effect is determined by how readily the material volatilizes, which is both concentration and matrix dependent. Therefore, even if a sample contains materials that could volatilize, it may still be possible to make accurate readings using the chilled-mirror dew point sensor.

The AQUALAB TDL provides a solution for products containing volatile materials. The TDL uses a tunable diode laser which shines light of a controlled wavelength, specific to water vapor, at a detector that receives light from the laser. The vapor pressure of the headspace of the instrument in equilibrium is determined by the loss of signal strength from the laser caused by the presence of water vapor in the headspace. For more information, contact [Customer Support](#).

3.3.4 WATER POTENTIAL

Water activity is closely related to a thermodynamic property called the water potential, or chemical potential (μ) of water, which is the change in Gibbs free energy (ΔG) when water concentration changes. Equilibrium occurs in a system when μ is the same everywhere in the system. Equilibrium between the liquid and the vapor phases implies that μ is the same in both phases. This means the measured water potential of the vapor phase can be used to determine the water potential of the liquid phase. Gradients in μ are driving forces for moisture movement. In an isothermal system, water tends to move from regions of high

water potential (high a_w) to regions of low water potential (low a_w). Moisture content is not a driving force for water movement and, therefore, cannot be used to predict the direction of water movement, except in homogeneous materials.

3.3.5 SORPTION ISOTHERMS

Changes in moisture content affect both the osmotic and matric binding of water in a product. Thus, a relationship exists between the water activity and moisture content. This relationship is called the sorption isotherm and is unique for each product. Besides being unique to each product, the isotherm changes depending on whether it was obtained by drying or wetting the sample. Typically, large safety margins are built into moisture content specifications to allow for these uncertainties.

While the sorption isotherm is often used to infer water activity from moisture content, one could easily go the other direction and infer moisture content from water activity. This is particularly attractive because water activity can be measured much more quickly than moisture content. This method gives particularly good precision in the center of the isotherm. In order to infer moisture content from water activity, an isotherm for the particular product is needed. METER can run the isotherm for a fee. Visit metergroup.com/food/services/water-activity-and-isotherm-testing for more information.

For example, if using the AQUALAB 4 to monitor the moisture content of dried potato flakes, measure the water activity and moisture content of potato flakes dried to varying degrees using the standard drying process for those flakes. That data is used to construct an isotherm and infer the moisture content using the measured water activity of samples and that isotherm. The DUO functionality enables users to determine moisture content and water activity simultaneously.

4. SERVICE

This section contains calibration and verification information, cleaning and maintenance guidelines, troubleshooting steps, and customer support information.

4.1 VERIFICATION AND CALIBRATION

It is important to verify the AQUALAB 4 water activity calibration against known standards to guarantee optimal performance and accuracy. METER recommends verification or once per shift or daily before use.

METER also recommends annual factory calibration to maintain optimal performance.

4.1.1 WATER ACTIVITY VERIFICATION

The AQUALAB 4 uses the chilled-mirror dew point technique to determine water activity. Because this is a primary measurement of relative humidity, no calibration is necessary; however, METER recommends periodic verification. The components used by the instrument to measure water activity are subject to contamination, which may affect AQUALAB 4 performance. Therefore, frequent verification assures that the AQUALAB 4 is performing correctly. In addition, providing a linear offset can be used to overcome any additional instrument drift.

VERIFICATION STANDARDS

Verification standards are specially prepared, unsaturated salt solutions having a specific molality and water activity value that are accurately measurable. The verification standards that were sent with the initial shipment are very accurate and readily available from METER. Using verification standards to verify accuracy can greatly reduce preparation errors. Performance Verification Standards come in seven water activity levels: 1.000, 0.984, 0.920, 0.760, 0.500, 0.250, and 0.150 a_w (Table 3). The standards are produced under a strict quality assurance regime. Please contact [Customer Support](#).

Table 3 Verification standards

Verification Standard at 25 °C	Dew Point a_w	Capcitive a_w
17.18 mol/kg LiCl	0.150 ±0.005	0.150 ±0.015
13.41 mol/kg LiCl	0.250 ±0.003	0.250 ±0.015
8.57 mol/kg LiCl	0.500 ±0.003	0.500 ±0.015
6.00 mol/kg NaCl	0.760 ±0.003	0.760 ±0.015
2.33 mol/kg NaCl	0.920 ±0.003	0.920 ±0.015
0.50 mol/kg KCl	0.984 ±0.003	0.984 ±0.015
Steam Distilled Water	1.000 ±0.003	1.000 ±0.015

NOTE: NOTE: Safety Data Sheet (SDS) for these standards are available at metergroup.com/food/meter-safety-data-sheets.

To use a verification standard, remove the twist top and pour the contents into a sample cup. Information about the standard value and molality can be found printed on the outside of the plastic vial. If for some reason METER verification standards are not available, contact [Customer Support](#) for instructions on how to create a verification standard salt solution.

In TEV models, the capacitance sensor can exhibit hysteresis. When a high water activity standard or sample is measured, this may influence future readings. After measuring a high water activity sample, allow 1 h for the sensor to dry. Additionally, desiccant or activated carbon can be used to accelerate the drying process.

NOTE: NOTE: To avoid inaccurate water activity readings, verification standards should be used once immediately after opening. Do not store standards in sample cups for repeated use.

VERIFICATION OF CALIBRATION

Verification of the calibration should be performed regularly to ensure the AQUALAB 4 is operating within specification. METER recommends verification be run once per shift or prior to operation. The procedure for verification involves reading a sample of known water activity. METER recommends using a standard close to that of the sample being measured. If operating in volatiles mode using the capacitance sensor or measuring a broad range of water activity values, METER recommends bracket the sample range. Capacitance sensors can show significantly more drift when compared to a chilled mirror and can exhibit some nonlinear behavior. Verifications should not be performed with only water standards.

Checking the water activity of a standard solution checks for the possibility of unit contamination or shifts in the linear offset from other causes.

The following steps explain how to verify for linear offset of the AQUALAB 4 ([Figure 50](#)).

1. If measuring samples over a wide range of water activity values, select two standards that best bracket the region. If measuring a relatively narrow region, select a sample that most closely matches the sample range being measured.

For example, if testing for water activity readings ranging between 0.621 and 0.713, use the 8.57 mol/kg LiCl ($0.50 a_w$) standard for the first verification and the 6.00 mol/kg, NaCl ($0.76 a_w$) for the second verification.

NOTE: The AQUALAB 4 needs to warm up for approximately 15 min to make accurate readings.

2. Empty a vial of the lower water activity verification standard into a sample cup.
3. Place it in the AQUALAB 4 testing chamber. Make sure that the standard is as close to the instrument temperature as possible. See [Section 2.2.2](#) for detailed instructions.

NOTE: Make sure the rim and outside of the sample cup are clean.

4. Carefully close the lid and move the lever to the READ position.
5. Take two readings.

The water activity readings should be within $\pm 0.003 a_w$ of the given value for the dew point or ± 0.015 for capacitance when testing the verification standard. The standards will read at 25 °C. If other temperatures are required, refer to [Table 4](#).

Table 4 Temperature correction of verification standards

Temperature (°C)	17.18 mol/kg LiCl	13.41 mol/kg LiCl	8.57 mol/kg LiCl	6.00 mol/kg NaCl	2.33 mol/kg NaCl	0.50 mol/kg KCL	Water
	0.15 a_w	0.25 a_w	0.50 a_w	0.76 a_w	0.92 a_w	0.984 a_w	1.00 a_w
15	0.140	0.238	0.492	0.760	0.918	0.984	1.000
20	0.145	0.245	0.496	0.760	0.919	0.984	1.000
25	0.150	0.250	0.500	0.760	0.920	0.984	1.000
30	0.155	0.255	0.504	0.760	0.921	0.984	1.000
35	0.160	0.261	0.508	0.760	0.922	0.984	1.000
40	0.165	0.266	0.512	0.760	0.923	0.984	1.000
45	0.170	0.271	0.516	0.760	0.924	0.984	1.000
50	0.175	0.276	0.520	0.760	0.925	0.984	1.000

NOTE: The AQUALAB 4 measures these verification standards to $\pm 0.003 a_w$ with the dew point sensor and $\pm 0.015 a_w$ with the capacitance sensor.

6. The readings may lead to one of three outcomes.

- a. If the AQUALAB 4 reads within $\pm 0.003 a_w$ of the first verification standard for dew point and ± 0.015 for capacitance, take two readings of the second verification standard. The second water activity reading for the second verification standard should be within $\pm 0.003 a_w$ for the dew point and ± 0.015 for the capacitance sensors.
- b. If either verification standard is not correct, it is probably due to contamination of the sensor chamber. Clean and air out the chamber ([Section 4.2](#)) and repeat verification from [step 2](#).
- c. If readings are consistently outside the water activity of the first verification standard by more than $\pm 0.003 a_w$ for dew point and ± 0.015 for capacitance, a linear offset can be applied. Adjust the reading to match the correct verification standard value ([Section 4.1.2](#)).

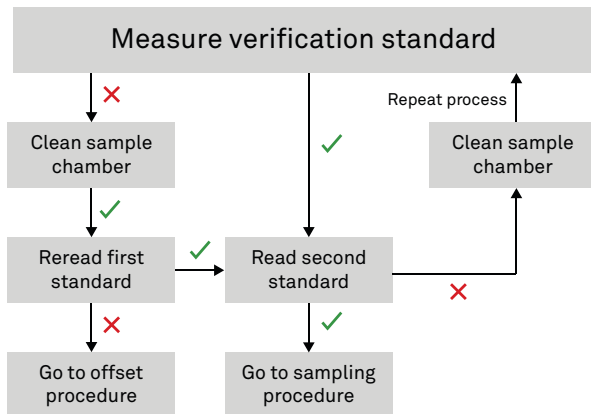

Figure 50 Verification standard flowchart. A check indicates AQUALAB 4 verified the standard within specification; a cross indicates AQUALAB 4 did not verify the standard within specifications.

4.1.2 LINEAR OFFSET

After verification and cleaning, the instrument an offset may be necessary.

1. Navigate to the Configuration tab.

For the AQUALAB 4TEV, the currently selected sensor for the instrument will be the one offset. Make sure to select the correct sensor before beginning the offset.

2. Select Calibration.
3. Select Water Activity.
4. Select Start (Figure 51).

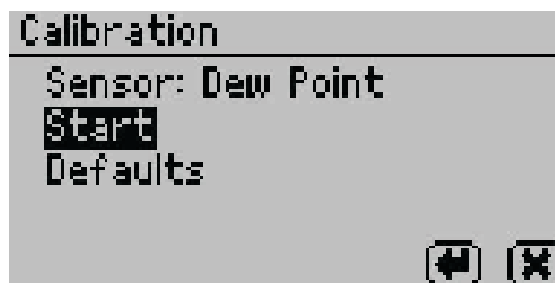

Figure 51 Start dew point calibration

To return to the prior tab, select CANCEL.

5. A prompt will appear to insert a fresh standard and seal the chamber (Figure 52).

NOTE: The same verification standard can be used to verify and adjust the linear offset. If using the same verification standard, do not open the sample chamber between verification and offset.

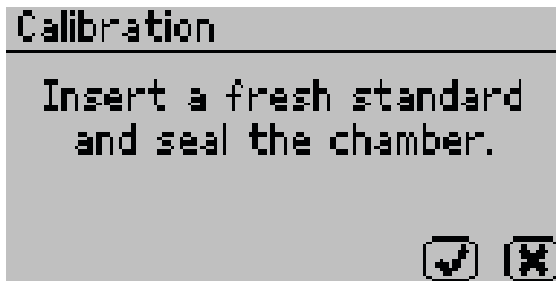

Figure 52 Calibration instruction dialog

6. Empty the whole vial of water activity standard into a sample cup.
METER recommends using the 6.00 NaCl (0.76 a_w). Do not adjust for the offset using steam distilled water.
7. Ensure the rim and outside of the cup are clean.
8. Place the sample cup in the sample chamber.
9. Carefully close the lid and move the lever to the READ position.
10. Select **OK** to begin testing.

NOTE: To interrupt the offset procedure, return the lever to the OPEN position or select **CANCEL** to return to the previous screen.

After the AQUALAB 4 has finished measuring the verification standard, it displays a Change the offset screen (Figure 53).

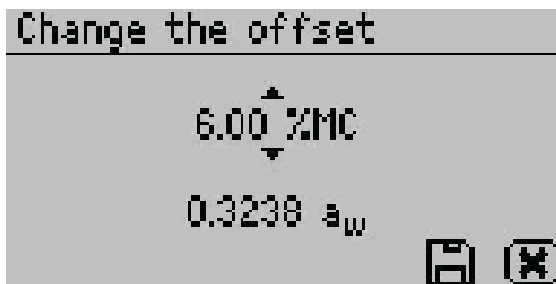

Figure 53 Change the offset screen

11. Use **UP** and **DOWN** to adjust the water activity reading to its proper value for the particular verification standard.
12. Select **SAVE** to store this new value.
To cancel and return to the main menu, select **CANCEL** to make no changes.
13. Restart the verification procedure in [Section 4.1.1](#).

If incorrect verification standard readings persist after cleaning the chamber and adjusting for linear offset, contact [Customer Support](#) for further instructions.

4.1.3 MULTIPPOINT CALIBRATION (TEV ONLY)

The capacitance sensor used for measuring the water activity of materials with volatiles (AQUALAB 4TEV models only) is a secondary method for measuring water activity and may require a slope change to the calibration in addition to a linear offset. This is the case when the offset in capacitance mode is different at high water activities than low water activities.

The 0.25, 0.50, 0.76, and 0.92 a_w unsaturated salt standards are needed to proceed with multipoint calibration.

1. Navigate to the Configuration tab.

For the AQUALAB 4TEV, make sure to select the capacitance sensor before beginning the multipoint calibration.

2. Select Calibration from the Configuration tab (Figure 54).

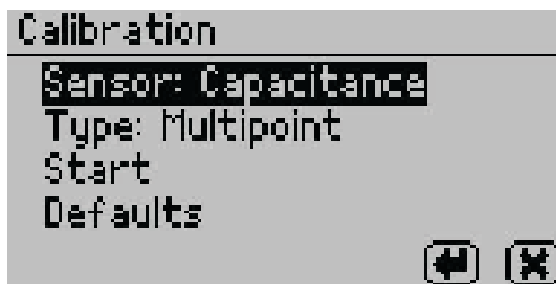

Figure 54 Capacitance sensor calibration screen

3. Highlight Type and select **ENTER** to toggle to Multipoint.
4. Select Start.

Prompts will instruct the user to insert a fresh standard and seal the chamber (Figure 55).

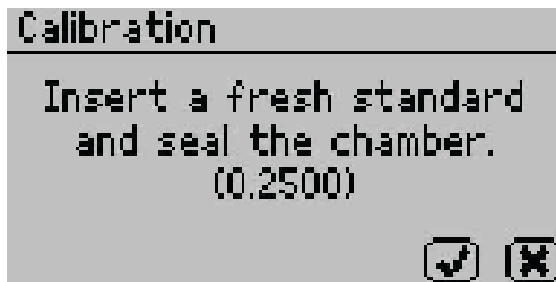

Figure 55 Prompt to insert fresh standard

5. Empty the whole vial of 0.25 a_w standard solution into a sample cup.
6. Ensure the rim and outside of the cup are clean.
7. Place the sample cup in the AQUALAB 4 sample chamber.

8. Carefully close the lid and move the lever to the READ position.
9. Select **OK** to begin testing.

After AQUALAB 4 has finished measuring the verification standard, a new screen appears requesting that a 0.50 a_w standard be placed in the chamber.

10. Repeat [steps 5](#) through [9](#) using 0.50, 0.76, and 0.92 a_w standards.

NOTE: To end the multipoint calibration program, select **CANCEL** to return to the previous screen.

When measurements are complete on all four standards, the Verification Complete screen appears showing the testing results for each standard ([Figure 56](#)).

Verification Complete		
Standard	Read	Error
0.250	0.254	0.004
0.500	0.492	-0.008
0.760	0.757	-0.003

Verification Complete		
Standard	Read	Error
0.920	0.928	0.008

Figure 56 Verification Complete screen with results

11. Select **OK** to continue or **CANCEL** to cancel the entire process.

NOTE: Select the audio icon to turn beeping on and off.

12. To make adjustments to the calibration, select **OK**.

Select **CANCEL** to cancel without adjusting the calibration ([Figure 57](#)).

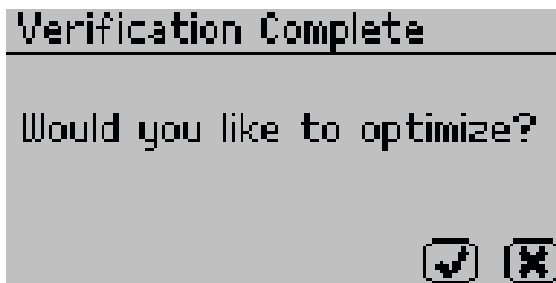

Figure 57 Prompt to adjust calibration

13. To save the new calibration changes, select **SAVE**.

To cancel the multipoint calibration without saving the new changes, select **CANCEL** ([Figure 58](#)).



Figure 58 Calibration Complete screen

Once the multipoint calibration is saved, a confirmation screen will appear (Figure 59).

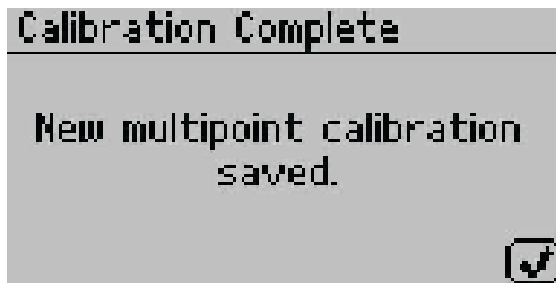

Figure 59 Calibration saved confirmation

14. Select **OK** to continue.
15. If the calibration is canceled at any point, a Calibration Canceled confirmation will appear. Select **OK** to continue (Figure 60).

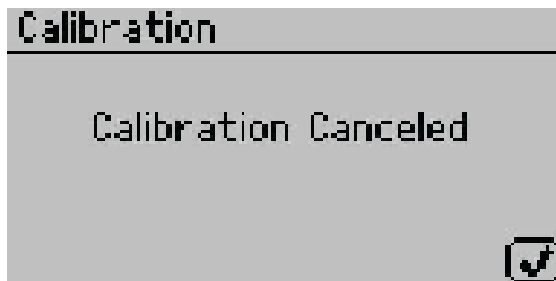

Figure 60 Calibration canceled confirmation

16. Let the sample chamber air out for at least 1 h.
17. Measure a 0.25 or 0.50 a_w verification standard in the Measurement tab (with capacitance sensor type).
18. Verify the AQUALAB 4 reads within $\pm 0.015 a_w$ at a given temperature.
19. Measure a 0.76 a_w verification standard according to the verification procedure detailed in [Section 4.1.1](#).

If both verification readings are within $\pm 0.015 a_w$, the instrument is ready to begin testing.

If incorrect verification standard readings persist, contact [Customer Support](#).

4.1.4 RESTORE FACTORY DEFAULTS

To restore original calibration settings, do the following:

1. Navigate to the Configuration tab using **MENU**.

NOTE: For TEV models, ensure the correct sensor is selected.

2. Select Calibration.
3. Select Water Activity.
4. Select Defaults to access the Restore Factory Defaults routine ([Figure 61](#)).

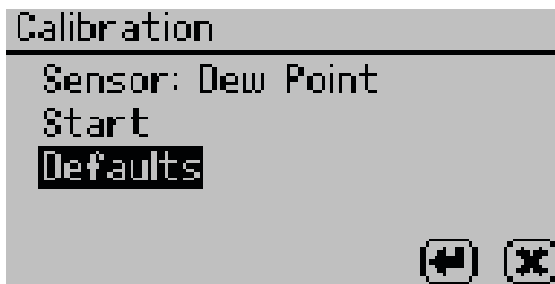

Figure 61 Calibration screen with Defaults selected

A confirmation dialog will appear ([Figure 62](#)).

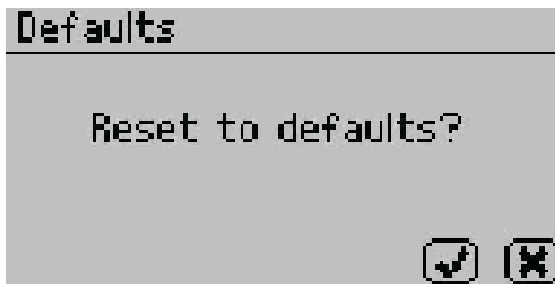

Figure 62 Confirmation dialog to reset defaults

5. Select **OK**.

Select **CANCEL** to return to the Calibration menu.

The instrument will confirm the factory calibration has been restored ([Figure 63](#)).

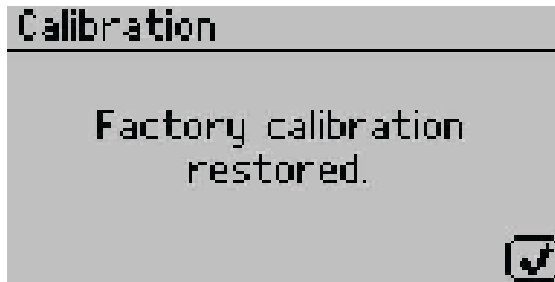

Figure 63 Confirmation that factory calibration was reset

6. Select OK.

4.2 CLEANING

Keeping the AQUALAB 4 clean is vital to maintaining the accuracy of the instrument. Dust and sampling debris can contaminate the sampling chamber, so regular cleaning is essential.

To clean the AQUALAB 4, carefully follow these instructions and refer to the labeled diagram in Figure 64. A video is also available at metergroup.com/meter_knowledgebase/aqualab-4te-certification.

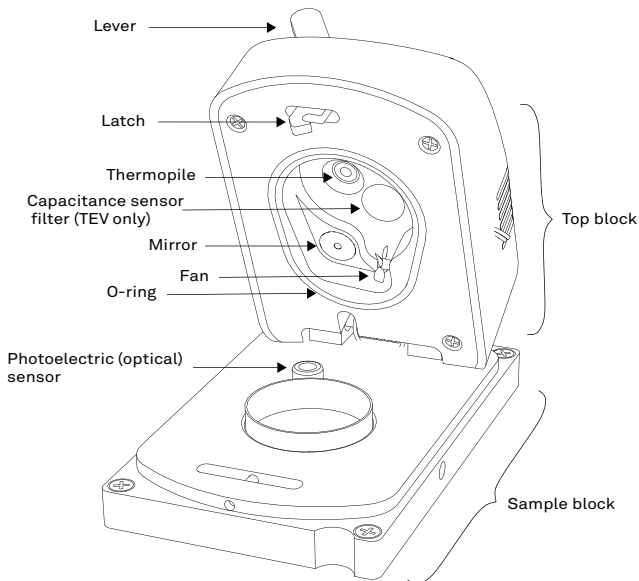

Figure 64 AQUALAB 4 sample chamber diagram

The purpose of the cleaning procedure is to remove grease, dirt, and other soluble substances that can absorb or release water during verification, calibration, or sample testing. The mirror must be perfectly clean for a smooth and even dew formation. If there are

any contaminants (e.g., fingerprints) on the mirror, the dew forms unevenly and can affect the accuracy of the reading.

The instrument should be cleaned if visual inspection indicates the chamber is dirty or as part of the verification process ([Section 4.1](#)).

4.2.1 CLEANING KIT

The AQUALAB 4 comes with an AQUALAB Cleaning Kit that contains enough cleaning supplies to clean the instrument for about 1 year. The following supplies are included:

- Spatula (a thin plastic rod)
- Deionized water for cleaning
- Cleaning Solution
- KIMWIPES® tissues
- Activated charcoal for removing volatile compounds from the chamber between readings

NOTE: Wash hands with soap and water, and wear clean gloves before starting the cleaning procedure. This prevents oils from contaminating the cleaning materials, the sample chamber, and the sensors.

4.2.2 AQUALAB 4TEV SPECIAL CONSIDERATIONS

When cleaning an AQUALAB 4TEV, do not get cleaning solution on the capacitance sensor filter ([Figure 64](#)). Repeated exposure of cleaning materials or contaminants to the filter may cause inaccurate readings. If the filter appears to be contaminated, it may need to be replaced.

To replace the capacitance sensor filter, use the following steps:

1. Use a tweezer or small knife blade to pry up the edge of the filter, being careful not to disturb the sensor beneath.
2. Discard the soiled filter.
3. With clean and gloved hands, gently press a new filter into place.

4.2.3 CLEANING PROCEDURE

The procedure to clean AQUALAB 4 involves washing, rinsing, and drying each area.

NOTE: Isopropyl alcohol can be substituted for the Cleaning Solution.

1. Turn the AQUALAB 4 power OFF.
2. Open the chamber cover to expose the sample chamber and sensors.
3. Clean the sample chamber. The sample chamber consists of all surfaces inside the red O-ring when the lid is closed.

NOTE: Be extremely careful not to damage the fan blades when cleaning the chamber.

- a. Remove any debris that may have collected within or around the sample chamber.

- b. Wrap a new tissue around the end of the spatula and moisten it with cleaning solution.

NOTE: Do not dip used tissue into the cleaning solution as the cleaning solution will become contaminated.

- c. Clean upper chamber, O-ring, and all surfaces of the sample block within the red O-ring. Replace the tissue if it becomes too dirty during this process.
- d. Clean lower block with a fresh KIMWIPES tissue. Clean the entire block surface.
- e. Repeat [steps b](#) through [d](#) using a new tissue moistened with deionized water.
- f. Repeat [steps b](#) through [d](#) using a new, dry KIMWIPES tissue to remove any moisture remaining from the cleaning.

NOTE: Do not reuse tissues.

4. Clean the mirror.
 - a. Wrap a new KIMWIPES tissue around the end of the spatula and moisten it with cleaning solution.
 - b. Gently swipe the moistened tissue across the mirror once. A single swipe is usually sufficient to remove contaminants.
 - c. Repeat [steps a](#) and [b](#) using a new tissue moistened with deionized water.
 - d. Repeat [steps a](#) and [b](#) using a new, dry KIMWIPES tissue to remove any moisture remaining from the cleaning.
 - e. Visually inspect the mirror for cleanliness. Clean again if necessary.
5. Clean the thermopile and optical sensor.
 - a. Wrap a new KIMWIPES tissue around the end of the spatula and moisten it with cleaning solution.
 - b. Swipe the moistened tissue across thermopile and optical sensor. A single swipe across the sensor is usually sufficient to remove contaminants.
 - c. Repeat [steps a](#) and [b](#) using a new tissue moistened with deionized water.
 - d. Repeat [steps a](#) and [b](#) using a new, dry KIMWIPES tissue to remove any moisture remaining from the cleaning.
 - e. Visually inspect the thermopile and optical sensor for cleanliness. Clean again, if necessary.
6. Visually inspect the sample chamber and sensors for contaminants, including moisture. If necessary, repeat the cleaning process using new KIMWIPES tissues.
7. Let stand for 5 min to ensure the sample chamber is dry.
8. After cleaning the AQUALAB 4, check the instrument performance and correct for any linear offset that may have occurred during the cleaning process.
 - a. Run a sample of the activated charcoal pellets from the AQUALAB Cleaning Kit.

This cleans the air inside the chamber, helping it come back to a stable sampling environment.

- b. Verify the linear offset against known verification standards as described in [Section 4.1.2](#).
- c. If a linear offset has occurred, adjust for linear offset.

If the instrument is still not reading samples correctly, contact [Customer Support](#).

4.3 MAINTENANCE PACKAGES

METER offers maintenance and calibration packages to ensure AQUALAB is functioning to its highest standard ([Table 5](#)).

Table 5 Maintenance package options

Package	Preventative Maintenance	Basic Calibration Service
As-found inspection	Available	Available
Replace old/damaged parts	Included	Separate charge per part
Instrument cleaning	Included	Included
Factory calibration	Included	Included
Extended 1-year warranty	Included	Not included
Loaner instrument	Available	Available

Replacement parts can also be ordered from METER. Contact [Customer Support](#).

4.4 REPAIR

METER repairs manufacturer defects and instruments within the 1-year warranty at no charge. Repairs outside of the warranty window are charged based on cost of parts, labor, and shipping. An extra fee may be charged for rush work. Contact [Customer Support](#) for an estimated repair cost.

METER has loaner instruments available for a fee while the AQUALAB is being serviced.

All AQUALAB units returning to METER for servicing must be accompanied with a Return Merchandise Authorization (RMA) number. Prior to shipping the instrument, contact [Customer Support](#) to obtain an RMA number.

1. Place the AQUALAB in a plastic bag to avoid disfiguring marks from the packaging.
2. Do not ship the power cord, serial cable, or any other accessories.
3. Ship the AQUALAB in its original cardboard box with suspension packaging.

If the original packaging is not available, use a box with at least 4 in of packing material (e.g., Styrofoam™ peanuts or bubble wrap) between the instrument and each wall of the box, ensuring the instrument is suspended in the packing material.

4. On the RMA form, please verify the ship to and bill to information, contact name, and problem description. If anything is incorrect, please contact [Customer Support](#).

5. Tape the box in both directions for added support.
6. Include the RMA number in the attention line on the shipping label.

A Certificate of Calibration will be issued upon completion of the work.

4.5 TROUBLESHOOTING

Table 6 lists common problems and their solutions. If the problem is not listed or these solutions do not solve the issue, contact [Customer Support](#).

Table 6 Troubleshooting the AQUALAB 4

Problem	Possible Solutions
AQUALAB does not turn on	<p>Ensure power cord is securely attached to the back of the instrument and plugged into the power outlet.</p> <p>A power surge may have caused a fuse to blow. To change the fuses:</p> <ul style="list-style-type: none"> • Unplug the power cord. • Locate the panel where the power cord plugs in. The fuse box is on the right side of that panel. Press the release tab and pull the fuse-holder out. • Pull the broken fuse out and replace with a 1.25-A, 250-V fuse. <p>CAUTION: Do not use any other kind of fuse to avoid risk of damaging the instrument or voiding the warranty.</p> <ul style="list-style-type: none"> • Replace the fuse holder and push it into the fuse well until the release tab snaps in place. • Connect the power cord and turn the instrument on. <p>If the fuse blows again, a failed component may be causing the problem. Contact Customer Support to make arrangements for repairs.</p>
Water activity readings on verification standards are too high or too low and a linear offset adjustment cannot be made any higher or lower	<p>The thermopile, which measures sample temperature, may have become contaminated. Refer to Section 4.2 for directions on cleaning.</p> <p>The chamber mirror may be dirty. Refer to Section 4.2 for directions on cleaning.</p>
Remove sample. Sample is too hot! error message	<p>The sample temperature is too high for the instrument to equilibrate within a reasonable amount of time. Ensure samples are at the same temperature as the instrument (Section 2.2.2).</p>

Table 6 Troubleshooting the AQUALAB 4 (continued)

Problem	Possible Solutions
Readings are slow or inconsistent	<p>The sample chamber may be dirty. Refer to Section 4.2 for directions on cleaning the sample chamber.</p> <p>The temperature difference between the sample and the block chamber may be too great. Allow the sample to equilibrate to instrument temperature. Refer to Section 2.2.2.</p> <p>Some products absorb or desorb moisture very slowly, causing measurements to take longer than usual, and nothing can be done to speed up the process. Refer to Section 2.2.1.</p> <p>The sample may contain volatiles. Refer to Section for suggestions on reducing difficulties with measuring samples with volatile compounds.</p> <p>A fan blade in the block chamber may be broken or bent. If salt standards take a long time to read and the sample chamber is clean, a broken chamber fan blade is the probable cause. Contact Customer Support for details on replacement.</p>
Displayed a_w is below instrument detection limits	<p>The sample is too dry for the instrument to read accurately. If a sample has a water activity that is less than the detection limits of the instrument, this message appears. There is not enough sample moisture to condense on the mirror and provide a reading.</p> <p>The mirror may be dirty. Clean the mirror and chamber (Section 4.2) and measure the sample again.</p>
Dew point sensor failure error message	The cooler is damaged and needs to be serviced by METER. Refer to Section 4.4 for detailed instructions.
Crystal Failure. See Manual for options. error message	The crystal that runs the firmware is having trouble starting. Cycle the power. If this message continues to appear, the instrument needs to be serviced by METER (Section 4.4).
Verification is not correct	<p>Clean the sample chamber and mirror. Refer to Section 4.2 for detailed cleaning instructions.</p> <p>If verification is still not correct, verify and adjust for linear offset (Section 4.1.2).</p>
Contaminated mirror. error message	Clean the chamber mirror (Section 4.2) and run the sample again. If this message continues to appear, contact Customer Support for further options.
Firmware is corrupted. See Manual for options. error message	The firmware on the instrument is corrupted and needs to be reloaded. To download new firmware to the AQUALAB 4 models, the instrument must be serviced by METER (Section 4.4).

Table 6 Troubleshooting the AQUALAB 4 (continued)

Problem	Possible Solutions
Moisture content displayed is not correct	<p>The model selected may not be correct for the product being tested.</p> <p>Toggle through the available models to find a more appropriate model.</p> <p>If the model is correct but not giving correct moisture content values, it may be necessary to offset the model. See Section 2.6 for detailed instructions.</p> <p>If the model is correct and an offset does not work, it may be necessary to generate a new model for the product or update an existing model. For information about updating or generating a model, contact Customer Support.</p>
Moisture content does not show up on the Measurement tab	<p>Moisture content has not been activated.</p> <p>Toggle to the Configuration tab, select %Moisture, and select the appropriate model.</p> <p>If no models appear in the %Moisture screen, reload models using AquaLink 4.</p>
Message on the Measurement tab displays no moisture content reading	<p>When a moisture content reading is not shown, the water activity or temperature for that reading is beyond the scope of the moisture sorption isotherm. This can happen under the following two conditions:</p> <ul style="list-style-type: none"> • The isotherm equation calculates a moisture content that is less than 0% or greater than 100% with the given water activity. • The control temperature is significantly different than the isotherm temperature. Make sure that the sample water activity and the instrument controlling temperature are within the scope of the selected moisture sorption isotherm model.
Sensors are reading outside of the typical range	<p>If, after cleaning the instrument and following troubleshooting guidelines, there is still a measurement error, navigate to the Diagnostics screen.</p> <p>The lid, base, and sample temperatures should be between 24.5 and 25.5 °C. If the mirror temperature is at lid temperature, the cooler has failed and must be replaced. If the mirror is below lid temperature or appears to be random, the thermocouple wire is broken and must be repaired.</p> <p>A typical optical range is between 300 and 2,900 mV. If the sensor is reading outside of this range, contact Customer Support.</p>

4.6 CUSTOMER SUPPORT

NORTH AMERICA

Customer service representatives are available for questions, problems, or feedback Monday through Friday, 7:00 am to 5:00 pm Pacific time.

Email: support.food@metergroup.com
sales.food@metergroup.com

Phone: +1.509.332.5601

Fax: +1.509.332.5158

Website: metergroup.com

EUROPE

Customer service representatives are available for questions, problems, or feedback Monday through Friday, 8:00 to 17:00 Central European time.

Email: support.europe@metergroup.com
sales.europe@metergroup.com

Phone: +49 89 12 66 52 36

Fax: +49 89 12 66 52 20

Website: metergroup.de

If contacting METER by email, please include the following information:

Name	Email address
Address	Instrument serial number
Phone	Description of the problem

NOTE: NOTE: For products purchased through a distributor, please contact the distributor directly for assistance.

4.7 TERMS AND CONDITIONS

By using METER instruments and documentation, you agree to abide by the METER Group, Inc. USA Terms and Conditions. Please refer to metergroup.com/terms-conditions for details.

REFERENCE

Labuza, Ted P., K. Acott, S. R. Tatini, R. Y. Lee, J. Flink, and W. McCall (1976). "Water activity determination: A collaborative study of different methods." *Journal of Food Science* 41, no. 4: 910–917.

INDEX

A

accuracy 6,20
 admin settings 30–32
 annual calibration service 40,52
 AQUALAB models 1
 autosave 29,32

B

beep 25,32

C

calibration 27,40
 multipoint 45–48
 restore 48–49
 capacitance sensor 23,28,33
 cautions 2,7
 Certificate of Calibration 53
 charcoal 5,7,50,51
 cleaning 49–51
 capacitance sensor filter 50
 cleaning kit 50–51
 procedure 50–51
 components 21–35
 buttons 23–24,25
 display screen 24–35
 Configuration tab 26–33
 Data tab 33–35
 Measurement tab 25–26
 fan 23
 optical sensor 22,23
 power cord 22
 RS-232 cable 21,22
 sample chamber 22–23
 shipped 1
 thermopile 23,51
 USB cable 21,22
 Configuration tab 26–33

contamination 2,40,41,42
 customer support 56

D

data
 delete 34–35
 view 34
 Data tab 33–35
 date 29
 dew point sensor 28,32,36
 diagnostics 32–37
 DUO model 39

E

email address 56

F

fan 23
 fax number 56
 fuse 2

G

Gibbs free energy 38

I

installation 2–3
 isotherm model
 model offset 10–13
 theory 39–40
 viewing 7,33

L

linear offset 32,33,40
 liquid phase water 36
 loaner instrument 52

M

maintenance 52
 matrix effects 38
 Measurement tab 25–26

microbial growth 35,38

mirror 5,22,23,38–39

mode

continuous 28

custom 28–29

ISO 28

low-emitting 29

print 32

single 28

moisture content

theory 35

value 7

O

osmotic effects 37

P

Peltier thermoelectric cooler 22,37

phone number 56

pressure effects 36

propylene glycol 38

R

read time 20

reference 57

regional formatting 30

relative humidity 5,21,33,36

repair 2,52–53

RMA number 52

S

sample composition 4–5

coated 3,4

dried 4

emulsions 5

multicomponent 3

viscous 5

volatile 5

sample cup 3–4,20

sample preparation 3–7

sample temperature 6–7

sensor 28

serial number 33

service 2

settings

beeps 32

date 29–30

language 30

mode 28–29

sensor 28

temp eq 27

temperature 30

time 30

specifications

compliance 21

measurement 20

physical 20–21

power voltage 2,21

T

temp eq 27–28

temperature 20,27

temperature effects 2,37–38

terms and conditions 56

theory

moisture content 35–36

sorption isotherm 39–40

water activity 35–37

water potential 38

thermometer 36,37

time 30

troubleshooting 53–55

U

user setup 31

V

vapor phase water 36

verification 40–42

verification standards 40–41,42

volatile compound 38. *See also* sample
composition, volatile

W

water activity 20

theory 35–37

water potential 38

METER Group, Inc. USA

2365 NE Hopkins Court, Pullman, WA 99163
T: +1.509.332.2756 F: +1.509.332.5158
E: info@metergroup.com W: metergroup.com

METER Group AG

Mettlacher Straße 8, 81379 München
T: +49 89 1266520 F: +49 89 12665220
E: info.europe@metergroup.com W: metergroup.de

