



1 **EU-TYPE EXAMINATION CERTIFICATE**

2 Equipment intended for use in Potentially Explosive Atmospheres Directive 2014/34/EU

3 Certificate Number: **Sira 18ATEX2088** Issue: **2**

4 Equipment: **BWC-1000, BWC-1001, BWC-1002, BWC-1003 and BWC-1004
Wireless IR to Bluetooth Transceiver**

5 Applicant: **RAE Systems, Inc. Honeywell Analytics Limited
A Honeywell Company**

6 Address: **1349 Moffett Park Dr. Hatch Pond House
Sunnyvale, CA 94089 4 Stinsford Road
USA Nuffield Estate
Poole
Dorset BH17 0RZ
United Kingdom**

7 This equipment and any acceptable variation thereto is specified in the schedule to this certificate and the documents therein referred to.

8 Sira Certification Service, notified body number 0518 in accordance with Articles 17 and 21 of Directive 2014/34/EU of the European Parliament and of the Council, dated 26 February 2014, certifies that this equipment has been found to comply with the Essential Health and Safety Requirements relating to the design and construction of equipment intended for use in potentially explosive atmospheres given in Annex II to the Directive.

The examination and test results are recorded in the confidential reports listed in Section 14.2.

9 Compliance with the Essential Health and Safety Requirements, with the exception of those listed in the schedule to this certificate, has been assured by compliance with the following documents:

EN 60079-0: 2012/A11:2013 EN 60079-11: 2012

The above list of documents may detail standards that do not appear on the UKAS Scope of Accreditation, but have been added through Sira's flexible scope of accreditation, which is available on request.

10 If the sign 'X' is placed after the certificate number, it indicates that the equipment is subject to Specific Conditions of Use identified in the schedule to this certificate.

11 This EU-Type Examination Certificate relates only to the design and construction of the specified equipment. If applicable, further requirements of this Directive apply to the manufacture and supply of this equipment.

12 The marking of the equipment shall include the following:



II 1 G
Ex ia IIC T4 Ga
Ta: -40°C to 55°C

Project Number 70200659

C Ellaby
Deputy Certification Manager

This certificate and its schedules may only be reproduced in its entirety and without change.



SCHEDULE

EU-TYPE EXAMINATION CERTIFICATE

Sira 18ATEX2088
Issue 2

13 DESCRIPTION OF EQUIPMENT

The subject equipment is a small, self-contained, battery powered, wireless, infrared to Bluetooth transceiver that communicates with hand-held portable gas detection instruments. The existing handheld instruments were designed with infrared transceiver capabilities, using a tiny optical port on the lower rear of the housing. This assembly is designed to physically mate with the existing instruments so that the optical ports on both devices align, enabling infrared digital information exchange. The device performs translation of this data and is provided with a wireless Bluetooth RF transceiver to exchange digital signal data with other (unspecified) Bluetooth devices located within a limited range of < 10 meters.

Several versions of this battery powered, self-contained device are available. One version utilizes an ultrasonically welded housing, and is designed to be disposable. The other version is provided with a two part housing that is held together with four M2 screws to facilitate battery replacement. Both of these variants are made available with, and without a momentary contact switch in the area where this device mounts to the "host" instrument.

All versions utilize a single 3V lithium manganese dioxide (Li/MnO₂) coin cell primary type battery, with a diameter of approximately 24.5 mm, by 5 mm thick as the only energy source. There is no wiring to or from this device. A periodically blinking LED signal on the front of the device is the only visible indication that the device is functioning.

The equipment is intended to mount directly to the rear surface face of a portable hand-held gas detection instrument. The geometry of a male boss, moulded into the rear of the housing is intended to mate with the geometry of a female boss moulded into the rear of the gas detection instrument, securing it in place.

Model BWC-1000 is the same as above, but it has an alternate mounting base.

Graphic Representation:

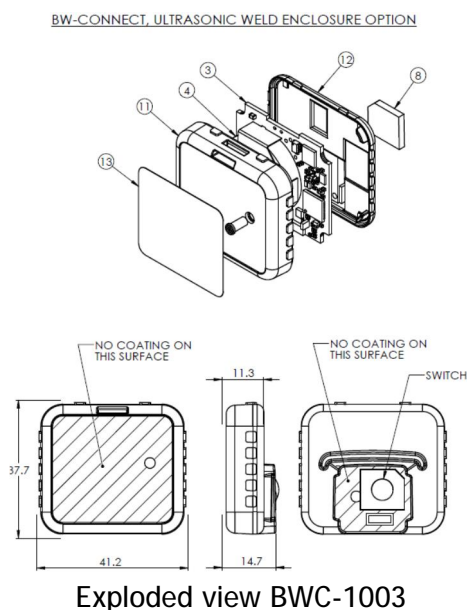

This certificate and its schedules may only be reproduced in its entirety and without change.



SCHEDULE

EU-TYPE EXAMINATION CERTIFICATE

Sira 18ATEX2088
Issue 2

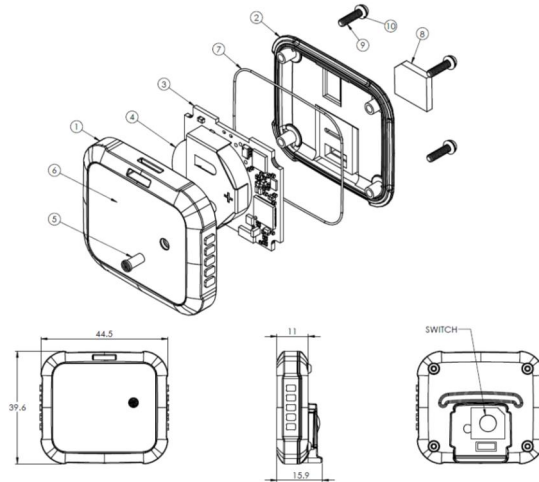

Exploded view – BWC 1002

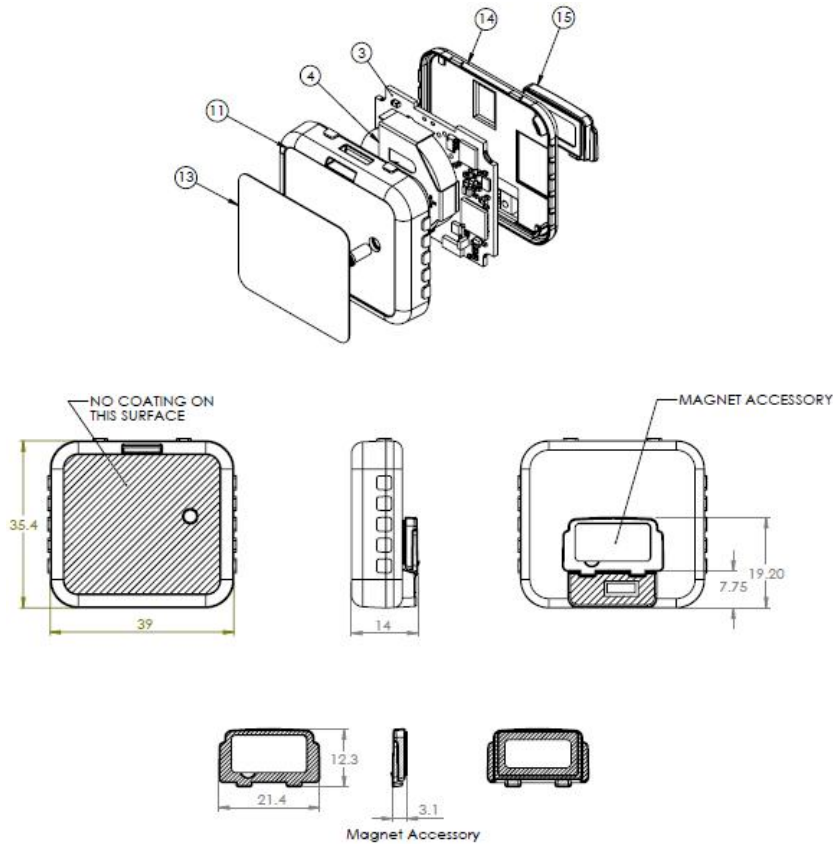

Exploded view – BWC 1000

This certificate and its schedules may only be reproduced in its entirety and without change.



SCHEDULE

EU-TYPE EXAMINATION CERTIFICATE

Sira 18ATEX2088
Issue 2



Examples of subject equipment, mounted to hand-held gas detection instruments.

Variation 1 - This variation introduced the following changes:

- i. The introduction of an additional model BWC-1000, which includes alternative structure for mounting base. The Marking and Equipment Description were revised to reflect the new Model BWC-1000.

Variation 2 - This variation introduced the following changes:

- i. Introduction of alternative Honeywell Analytics Limited factory to the Manufacturer's Name and Address.

14 DESCRIPTIVE DOCUMENTS

14.1 Drawings

Refer to Certificate Annexe.

14.2 Associated Sira Reports and Certificate History

Issue	Date	Report no.	Comment
0	14 June 2018	R70167238A	The release of the prime certificate.
1	30 August 2018	R70192706A	The introduction of Variation 1
2	01 November 2018	R70200659A	The introduction of Variation 2

15 SPECIFIC CONDITIONS OF USE (denoted by X after the certificate number)

None

16 ESSENTIAL HEALTH AND SAFETY REQUIREMENTS OF ANNEX II (EHSRs)

The relevant EHSRs that are not addressed by the standards listed in this certificate have been identified and individually assessed in the reports listed in Section 14.2.



SCHEDULE

EU-TYPE EXAMINATION CERTIFICATE

Sira 18ATEX2088
Issue 2

17 CONDITIONS OF MANUFACTURE

- 17.1 The use of this certificate is subject to the Regulations Applicable to Holders of Sira Certificates.
- 17.2 Holders of EU-Type Examination Certificates are required to comply with the conformity to type requirements defined in Article 13 of Directive 2014/34/EU.

This certificate and its schedules may only be reproduced in its entirety and without change.

Certificate Annexe



Certificate Number: Sira 18ATEX2088
Equipment: BWC-1000, BWC-1001, BWC-1002, BWC-1003 and BWC-1004
Wireless IR to Bluetooth Transceiver
Applicant: RAE Systems, Inc.

Issue 0

Drawing no.	Sheets	Rev.	Date (Sira stamp)	Title
A01-1109-000	1 to 15	D	29 MAY 18	SOJU Board (PC board layout)
A01-1119-BOM	1 of 1	5	29 MAY 18	Scheduled Bill of Materials – SOJU
A01-1119-SCH	1 of 1	5	29 MAY 18	Schematic – SOJU
A01-4009-LBL	1 of 1	A	29 MAY 18	Marking nameplate, IECEx/ATEX
T04-000X-ASSY	1 of 1	8	29 MAY 18	Assembly – BW Connect
T04-4002-CTL	1 to 2	A	12 JUN 18	Installation manual (<i>controlled part</i>)

Issue 1

Drawing no.	Sheets	Rev.	Date (Sira stamp)	Title
T04-000X-ASSY	1 to 2	10	03 Aug 18	Assembly – BW Connect and BW Connect with Magnet Base

Issue 2 - No new drawings were introduced.

This certificate and its schedules may only be reproduced in its entirety and without change.