



**V104n GPS Compass
User Guide**

Part No. 875-0347-0 Rev. A2

This device complies with part 15 of the FCC Rules. Operation is subject to the following two conditions:

- (1) This device may not cause harmful interference, and
- (2) this device must accept any interference received, including interference that may cause undesired operation.

This product complies with the essential requirements and other relevant provisions of Directive 2014/53/EU. The declaration of conformity may be consulted at <https://hemispheregnss.com/About-Us/Quality-Commitment>.

Copyright Notice

Copyright Hemisphere GNSS, Inc. (2017). All rights reserved.

No part of this manual may be reproduced, transmitted, transcribed, stored in a retrieval system or translated into any language or computer language, in any form or by any means, electronic, mechanical, magnetic, optical, chemical, manual or otherwise, without the prior written permission of Hemisphere GNSS.

Trademarks

Hemisphere GNSS®, the Hemisphere GNSS logo, COAST™, PocketMAX™, Crescent® and Vector™ are proprietary trademarks of Hemisphere GNSS, Inc. Other trademarks are the properties of their respective owners.

Patents

Hemisphere GNSS products may be covered by one or more of the following patents:

<u>U.S. Patents</u>					<u>Australia Patents</u>
6111549	6876920	7400956	8000381	8214111	2002244539
6397147	7142956	7429952	8018376	8217833	2002325645
6469663	7162348	7437230	8085196	8265826	2004320401
6501346	7277792	7460942	8102325	8271194	
6539303	7292185	7689354	8138970	8307535	
6549091	7292186	7808428	8140223	8311696	
6711501	7373231	7835832	8174437	8334804	
6744404	7388539	7885745	8184050	RE41358	
6865465	7400294	7948769	8190337		

Other U.S. and foreign patents pending.

Notice to Customers

Contact your local dealer for technical assistance. To find the authorized dealer near you:

Hemisphere GNSS
8515 East Anderson Drive, Suite A
Scottsdale, Arizona, US 85255
Phone: 480-348-6380
Fax: 480-270-5070
precision@hgns.com www.hgns.com

Technical Support

If you need to contact Hemisphere GNSS Technical Support:

Hemisphere GNSS
8515 East Anderson Drive, Suite A
Scottsdale, Arizona, US 85255
Phone: 480-348-6380
Fax: 480-270-5070
techsupport@hemispheregnss.com

Documentation Feedback

Hemisphere GNSS is committed to the quality and continuous improvement of our products and services. We urge you to provide Hemisphere GNSS with any feedback regarding this guide by writing to the following email address: techsupport@hgns.com.

Contents

Chapter 1	Introduction	
	Overview	2
	Parts List	3
Chapter 2	V104n Installation	
	Mounting Location	6
	GPS Reception	6
	V104n Environmental Considerations	6
	VHF Interference	7
	Mounting Orientation.....	9
	V104n Alignment.....	11
	Mounting Options	12
	V104n Dimensions.....	12
	Cable Considerations	14
	Flush Mount	15
	Pole Mount	17
	Powering and Connecting to the V104n.....	20
	Power Considerations	20
	Electrical Isolation	20
	NMEA 2000 Port.....	21
Chapter 3	Operation	
	GPS Overview	24
	GPS Operation	24

Contents		
	Differential Operation	25
	V104n Overview	26
	Supplemental Sensors	26
	Time Constants.....	29
	Watchdog	29
	Common Commands and Messages.....	30
	End User License Agreement	47
	Warranty Notice	50

Chapter 1: Introduction

Overview

Parts List

Overview

The V104n™ GPS Compass is based upon Hemisphere GNSS' exclusive Crescent® and Crescent Vector™ II technology.

The V104n is a complete GPS compass and position system in a single enclosure that requires a standard NMEA 2000 cable connection. With NMEA 2000 support and ease of installation, the V104n is the perfect solution for marine-based applications.

The V104n is an integrated system that houses the following:

- Crescent and Crescent Vector II technology
- Dual integrated GPS antennas
- Power supply
- Single axis gyro
- Tilt sensor on each axis (X and Y axes)

The gyro and tilt sensors are present to improve system performance and to provide backup heading information in the event that a GPS heading is not available due to signal blockage.

Crescent Vector II technology supports multiple RF front ends - enabling tighter coupling of measurements from separate antennas for use in heading-based products. Users will achieve excellent accuracy and stability due to Crescent's more accurate code phase measurements, improved multi-path mitigation, and fewer components.

The V104n's GPS antennas are separated by 13.5 cm between their phase centers, resulting in better than 2° rms heading performance. The V104n provides heading and position updates of up to 10 Hz and delivers position accuracy of better than 1.0 m 95% of the time when using differential GPS corrections from Space Based Augmentation Systems (SBAS).

The V104n also features Hemisphere GNSS' exclusive COAST™ technology that enables Hemisphere GNSS receivers to utilize old differential GPS correction data for 40 minutes or more without significantly affecting the position quality. The V104n is less likely to be affected by differential signal outages due to signal blockages, weak signals, or interference when using COAST.

If you are new to GPS and SBAS, refer to the GPS Technical Reference for further information on these services and technologies before proceeding. The GPS Technical Reference is available from the Hemisphere GNSS website at www.hemispheregnss.com.

Parts List

Note: The V104n's parts comply with IEC 60945 Section 4.4: "exposed to the weather."

Table 1-1: Parts list for V104n

Part Name	Qty	Part Number
V104n GPS Compass (NMEA 2000)	1	804-0128-0
Screw Housing Caps	2	675-0173-0
Mounting Screws	2	675-1199-000#
Mounting Base	1	676-0035-0
Mounting Nut	1	676-1021-000#
Screw Housing Cap O-Rings	2	681-1066-0

This User Guide is available for download from the Hemisphere GNSS website at www.hgnss.com.

Chapter 1: Introduction

Chapter 2: V104n Installation

Mounting Location

Mounting Orientation

Mounting Options

Powering and Connecting to the V104n

Connecting the V104 to External Devices

Mounting Location

This section provides information on determining the best location for the V104n.

GPS Reception

When considering where to mount the V104n, consider the following GPS reception recommendations:

- Ensure there is a clear view of the sky available to the V104n so the GPS and SBAS satellites are not masked by obstructions that may reduce system performance.
- Since the V104n computes a position based on the internal GPS antenna element, mount the V104n where you desire a position with respect to the GPS antenna (located on the side of the recessed arrow on the underside of the enclosure).
- Locate any transmitting antennas away from the V104n by at least several feet to ensure tracking performance is not compromised, giving you the best performance possible.
- Make sure there is enough cable length to tie into the NMEA 2000 backbone of the vessel.
- Do not locate the antenna where environmental conditions exceed those specified in Table B-5 on page 43.

V104n Environmental Considerations

The V104n is designed to withstand harsh environmental conditions; however, adhere to the following limits when storing and using the V104n:

- Operating temperature: -30°C to +70°C (-22°F to +158°F).
- Storage temperature: -40°C to +85°C (-40°F to +185°F).
- Humidity: 100% non-condensing.

VHF Interference

VHF interference from devices such as cellular phones and radio transmitters may interfere with GPS operation. For example, if installing the V104n near marine radios consider the following:

- VHF marine radio working frequencies (Channels 1 to 28 and 84 to 88) range from 156.05 to 157.40 MHz. The L1 GPS working center frequency is 1575.42 MHz. The bandwidth is +/- 2MHz to +/- 10 MHz, which is dependent on the GPS antenna and receiver design (see next page).
- VHF marine radios emit strong harmonics. The 10th harmonic of VHF radio, in some channels, falls into the GPS working frequency band, which may cause the SNR of GPS to degrade significantly.
- The radiated harmonic signal strength of different brands/models varies.
- Follow VHF radio manufacturers' recommendations on how to mount their radios and what devices to keep a safe distance away.
- Hand-held 5W VHF radios may not provide suitable filtering and may interfere with the V104n's operation if too close.

Before installing the V104n use the following diagram to ensure there are no nearby devices that may cause VHF interference.

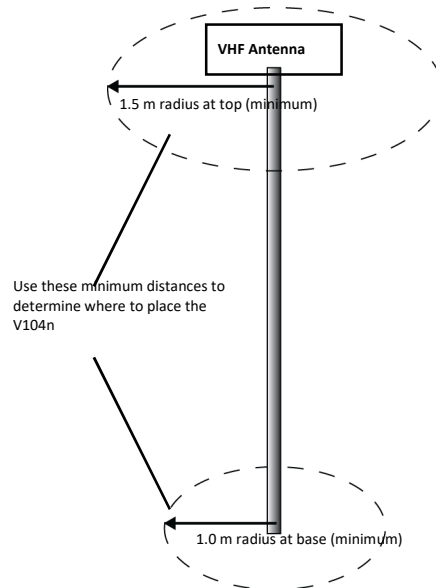

Figure 2-1: V104n distance from nearby VHF radios

Mounting Orientation

The V104n outputs heading, pitch, and roll readings regardless of the orientation of the antennas. The primary antenna is used for position. The primary and secondary antennas, working in conjunction, output heading, pitch, and roll values.

Parallel Orientation: The most common installation is to orient the V104n parallel to, and along the centerline of, the axis of the boat. This provides a true heading. In this orientation:

- If you use a gyrocompass, you can enter a heading bias in the V104n to calibrate the physical heading to the true heading of the vessel.
- You may need to adjust the pitch/roll output to calibrate the measurement if the Vector is not installed in a horizontal plane.

Perpendicular Orientation: You can also install the antennas so they are oriented perpendicular to the centerline of the boat's axis. In this orientation:

- You will need to enter a heading bias of +90° if the primary antenna is on the starboard side of the boat and -90° if the primary antenna is on the port side of the boat.
- You will need to configure the receiver to specify the GPS antennas are measuring the roll axis.
- You will need to enter a roll bias to properly output the pitch and roll values.
- You may need to adjust the pitch/roll output to calibrate the measurement if the Vector is not installed in a horizontal plane.

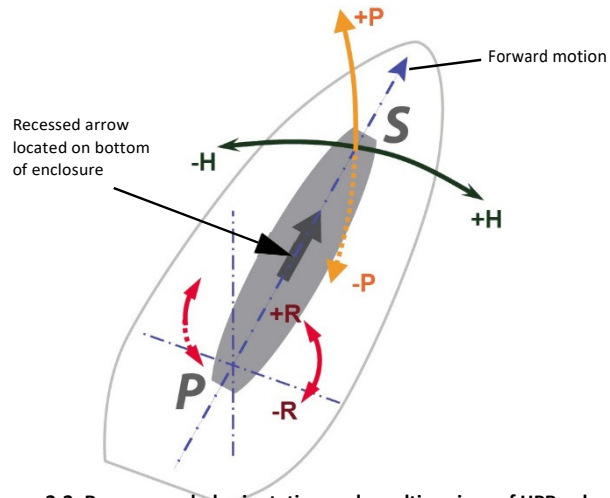

Figure 2-2: Recommended orientation and resulting signs of HPR values

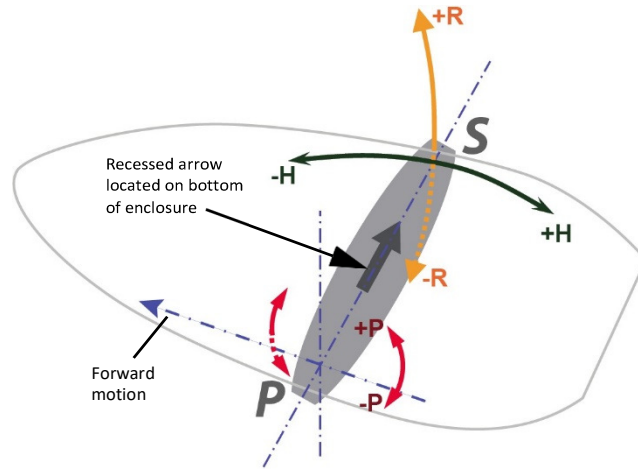

Figure 2-3: Alternate orientation and resulting signs of HPR values

V104n Alignment

The top of the V104n enclosure incorporates sight design features to help you align the enclosure with respect to an important feature on your vessel.

To use the sights, center the small post on the opposite side of the enclosure from you, within the channel made in the medallion located in the center of the enclosure top as shown in Figure 2-4 and Figure 2-5. Alignment accuracy when looking through the site (Figure 2-4) and (Figure 2-5) is approximately $\pm 1^\circ$.

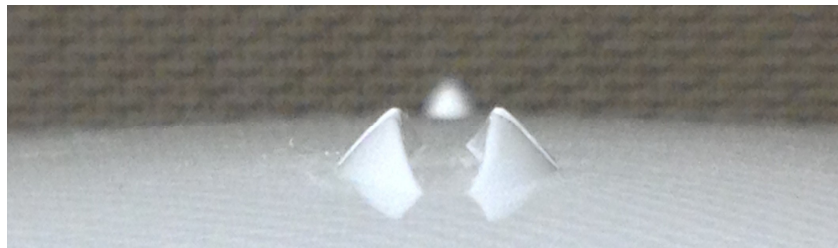

Figure 2-4: Long site alignment channel

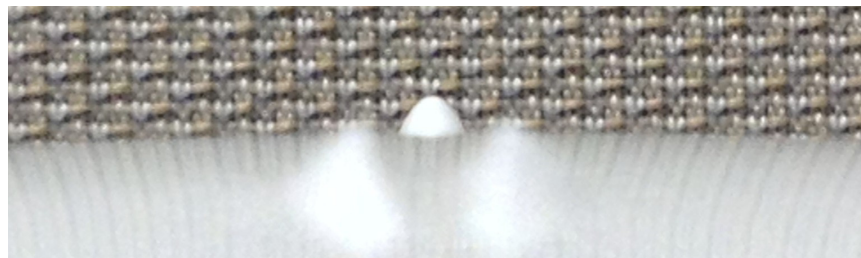

Figure 2-5: Long sight alignment center post

If you have another accurate source of heading data on your vessel, such as a gyrocompass, you may use its data to correct for a bias in V104n alignment within the V104n software configuration. Alternatively, you can physically adjust the heading of the V104n so that it renders the correct heading measurement; however, adding a software offset is an easier process.

Mounting Options

The V104n allows for both pole or flush mounting. Follow directions below for detailed mounting directions.

V104n Dimensions

Figure 2-6 and Figure 2-7 illustrates the physical dimensions of the V104n.

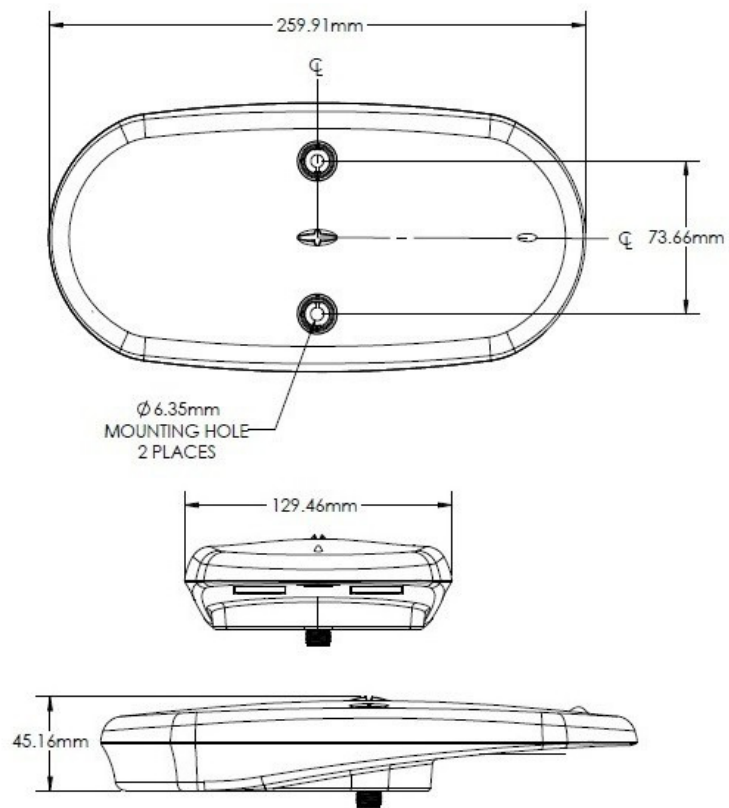

Figure 2-6: V104n dimensions

Chapter 2: Installation

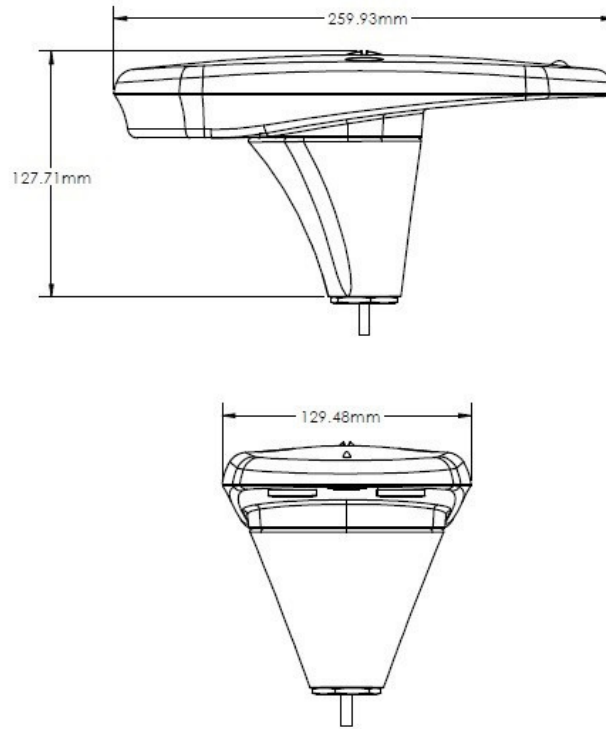

Figure 2-7: V104n Dimensions with Adapter

Cable Considerations

Before mounting the V104n consider the following regarding cable routing:

- Avoid running the cable in areas of excessive heat
- Keep cable away from corrosive chemicals
- Do not run the cable through door or window jams
- Keep cable away from rotating machinery
- Do not crimp or excessively bend the cable
- Avoid placing tension on the cable
- Remove unwanted slack from the cable at the V104n end
- Secure along the cable route using plastic wraps

▲WARNING: Improperly installed cable near machinery can be dangerous

Flush Mount

The bottom of the V104n contains two holes for flush mounting the unit to a flat surface (Figure 2-8). The flat surface may be something you fabricate per your installation, an off-the-shelf item (such as a radar mounting plate), or an existing surface on your vessel.

Note: Hemisphere GNSS does not supply the mounting surface hardware. You must supply the appropriate fastening hardware required to complete the installation of the V104n.



Figure 2-8: Flush mounting with holes in the V104n

Note: You do not necessarily need to orient the antenna precisely as you can enter a software offset to accommodate for any bias in heading measurement due to installation.

Before flush mounting the V104n

- Determine your mounting orientation. See “MountingOrientation” on page 9 for more information.
- Choose a location that meets the mounting location requirements.
- Using the fixed base as a template, mark and drill the mounting holes as necessary for the mounting surface.

Flush mounting the V104n

1. Mark the mounting hole centers and connector center on the mounting surface.
2. Place the V104n over the marks to ensure the planned hole centers align with the true hole centers (adjusting as necessary).
3. Use a center punch to mark the hole centers.
4. Drill the mounting holes to a diameter of 6.8mm (0.26 in) appropriate for the surface.
5. Drill the connector hole to a diameter of 28.6mm (1.13 in) appropriate for the surface.
6. Pull the cable through the center connector hole and attach the cable directly to the V104n, ensuring the connector is fastened securely to the unit.
7. Place the V104n over the mounting holes and insert the mounting screws through the top of the V104n and through the mounting surface.
8. Use two M6 washers and M6 nuts to secure the V104n to the mounting plate (washers and nuts not included).

▲WARNING: When installing the V104n, hand tighten only. Damage resulting from over-tightening is not covered by the warranty.

Pole Mount



Before pole mounting the V104n

- Determine your mounting orientation. See “MountingOrientation” on page 9 for more information.
- Choose a location that meets the mounting location requirements.
- Mark and drill the mounting holes as necessary for the threaded pole.

Pole mounting instructions for V104n (Inside Pole)

Required tools: 5 mm Allen key for M6 screws and adjustable wrench to tighten jam nut

1. Insert mating cable through both the jam nut and 1" (25.4mm) mounting adapter base
2. Place the jam nut on the pole followed by the 1" (25.4mm) adapter base. Hand tighten the base to the desired orientation.
3. Adjust the jam nut to secure the orientation.
4. Connect the mating end of the cable to the V104n connector located on the bottom of the unit.
5. Insert the base adapter into V104n by placing the tongue of the base into the groove of the V104n unit. When the tongue is properly seated in the groove, the rest of the base can be pressed into place to create a smooth seam between the base and V104n unit.
6. Use 5 mm Allen key to fasten two M6 screws to secure V104n onto adapter. Use 15 in-lb torque
7. Insert each o-ring onto a plastic cap
8. Install plastic cap with o-ring onto V104n unit (rectangular notch faced towards the outside)
9. Align and set the direction of V104n unit, while using the jam nut to secure the unit (hand-tighten).

▲WARNING: Over-tightening may damage the system. This is not covered under warranty.

Pole mounting instructions for V104n (Outside Pole)

Required tools: 5 mm Allen key for M6 screws and adjustable wrench to tighten jam nut

1. Place the jam nut on the pole followed by the 1" (25.4mm) adapter base. Hand tighten the base to the desired orientation.
2. Adjust the jam nut to secure the orientation.
3. Run the cable throughout the vessel making sure to leave enough slack to mate the NMEA 2000 cable to both the NMEA 2000 backbone and the V104n unit.
4. Run the NMEA 2000 cable through the opening in the side of the pole mounting adapter. And then connect the mating end of the cable to the V104 connector located on the bottom of the unit.
5. Insert the base adapter into V104n by placing the tongue of the base into the groove of the V104n unit. When the tongue is properly seated in the groove, the rest of the base can be pressed into place to create a smooth seam between the base and V104n unit.
6. Use 5 mm Allen key to fasten two M6 screws to secure V104n onto adapter. Use 15 in-lb torque
7. Insert each o-ring onto a plastic cap
8. Install plastic cap with o-ring onto V104n unit (rectangular notch faced towards the outside)
9. Align and set the direction of V104n unit, while using the jam nut to secure the unit (hand-tighten).

▲WARNING: Over-tightening may damage the system. This is not covered under warranty.

Connecting the NMEA 2000 cable

1. Align the NMEA 2000 cable connector key-way with the V104n connector key.

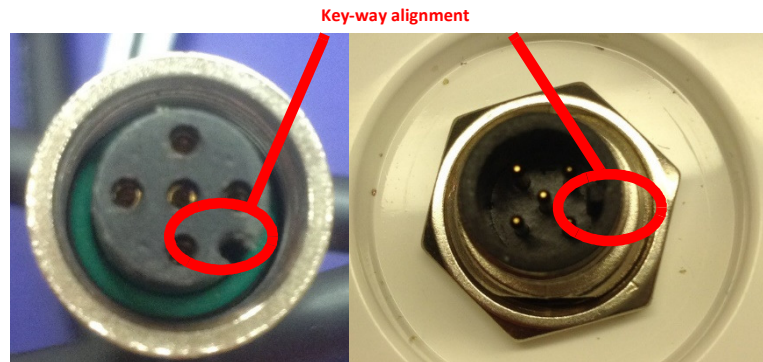

2. Rotate the cable ring clockwise until it is secured firmly to the unit (hand-tighten).

Powering and Connecting to the V104n

Power Considerations

For best performance, use clean and continuous power. The V104n power supply features reverse polarity protection but will not operate with reverse polarity.

See Table B-3 on page 43 for complete power specifications.

⚠ WARNING: Do not apply a voltage higher than 36 VDC. This will damage the receiver and void the warranty.

Electrical Isolation

The V104n's power supply is isolated from the communication lines and the PC-ABS plastic enclosure isolates the electronics mechanically from the vessel (addressing the issue of vessel hull electrolysis).

NMEA 2000 Cable Pin-out Specifications

Figure 2-9 show the power/data cable pin-out, while Table 2-1 shows the cable’s pin-out specifications.

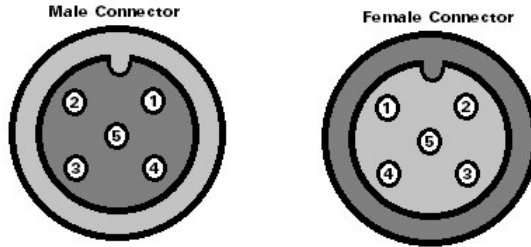

Figure 2-9: NMEA 2000 cable pin assignment

Table 2-1: NMEA 2000 cable pin-out

Pin	Function
1	Shield
2	Power Supply Positive (+V)
3	Power Supply Negative (-V)
4	CAN HI
5	CAN LOW

NMEA 2000 Port

The V104n uses proprietary NMEA 2000 PGN for receiver configuration. Please contact techsupport@hemispheregnss.com for a complete and up to date list of available proprietary PGN’s. With suitable USB-CAN hardware from Kvaser or PEAK, V104n can be connected to a Windows PC to use PocketMax or VectorPC for configuration and setup using the same serial commands as the NMEA0183 V104n.

Chapter 2: Installation

Chapter 3: Operation

GPS Overview

V104n Overview

Common Commands and Messages

GPS Overview

For your convenience, both the GPS and SBAS (WAAS, MSAS, GAGAN and EGNOS) operation of the V104n features automatic operational algorithms. When powered for the first time, the V104n performs a "cold start," which involves acquiring the available GPS satellites in view and the SBAS differential service.

GPS Operation

The GPS receiver is always operating, regardless of the DGPS mode of operation. The following sections describe the general operation of the V104n's internal GPS receiver.

Note: Differential source and status have no impact on heading, pitch, or roll. They only have an impact on position and heave.

Automatic Tracking

The V104n's internal GPS receiver automatically searches for GPS satellites, acquires the signals, and manages the navigation information required for position and tracking.

Receiver Performance

The V104n works by finding four or more GPS satellites in the visible sky. It uses information from the satellites to compute a position within 3 m. Since there is some error in the GPS data calculations, the V104n also tracks a differential correction. The V104n uses these corrections to improve its position accuracy to better than 1.0 m.

There are two main aspects of GPS receiver performance:

- Satellite acquisition
- Position and heading calculation

When the V104n is properly positioned, the satellites transmit coded information to the antennas on a specific frequency. This allows the receiver to calculate a range to each satellite from both antennas. GPS is essentially a timing system. The ranges are calculated by timing how long it takes for the

signal to reach the GPS antenna. The GPS receiver uses a complex algorithm incorporating satellite locations and ranges to each satellite to calculate the geographic location and heading. Reception of any four or more GPS signals allows the receiver to compute three-dimensional coordinates and a valid heading.

Differential Operation

The purpose of differential GPS (DGPS) is to remove the effects of selective availability (SA), atmospheric errors, timing errors, and satellite orbit errors, while enhancing system integrity. Autonomous position capabilities of the V104n will result in position accuracies of 3 m 95% of the time. In order to improve position quality to better than 1.0 m 95%, the V104n is able to use differential corrections received through the internal SBAS demodulator.

Automatic SBAS Tracking

The V104n automatically scans and tracks SBAS signals without the need to tune the receiver. The V104n features two-channel tracking that provides an enhanced ability to maintain a lock on an SBAS satellite when more than one satellite is in view. This redundant tracking approach results in more consistent tracking of an SBAS signal in areas where signal blockage of a satellite is possible.

V104n Overview

The V104n provides accurate and reliable heading and position information at high update rates. To accomplish this task, the V104n uses a high performance GPS receiver and two antennas for GPS signal processing. One antenna is designated as the primary GPS antenna and the other is the secondary GPS antenna. Positions computed by the V104n are referenced to the phase center of the primary GPS antenna. Heading data references the vector formed from the primary GPS antenna phase center to the secondary GPS antenna phase center.

The heading arrow located on the bottom of the V104n enclosure defines system orientation. The arrow points in the direction the heading measurement is computed (when the antenna is installed parallel to the fore-aft line of the vessel). The secondary antenna is directly above the arrow.

Supplemental Sensors

The V104n has an integrated gyro and two tilt sensors. The gyro and tilt sensors are enabled by default. Both supplemental sensors are mounted on the printed circuit board inside the V104n.

The sensors act to reduce the search volume, which improves heading startup and reacquisition times. This improves the reliability and accuracy of selecting the correct heading solution by eliminating other possible, erroneous solutions. Table 3-1 on page 27 provides a sensor operation summary.

Table 3-1: Sensor operation summary

Feature	Normal Operation	Coasting (no GPS)
Heading	GPS	Gyro
Pitch	GPS	Inertial sensor
Roll	Inertial sensor	Inertial sensor

Tilt Aiding

The V104n’s accelerometers (internal tilt sensors) are factory-calibrated and enabled by default. This allows for a steady heading solution beyond the volume associated with just a fixed antenna separation. This is because the V104n knows the approximate inclination of the secondary antenna with respect to the primary antenna. The search space defined by the tilt sensor will be reduced to a horizontal ring on the sphere’s surface by reducing the search volume. This considerably decreases startup and reacquisition times (see Figure 3-1).

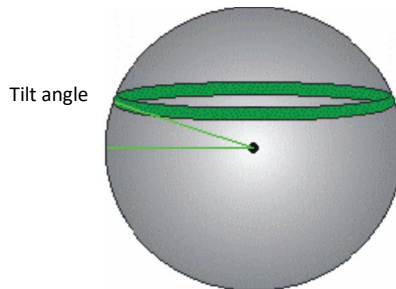

Figure 3-1: V104n’s tilt aiding

Gyro Aiding

The V104n’s internal gyro offers several benefits. It reduces the sensor volume to shorten reacquisition times when a GPS heading is lost because the satellite signals were blocked. The gyro provides a relative change in angle since the last computed heading, and, when used in conjunction with

the tilt sensor, defines the search space as a wedge-shaped location (see Figure 3-2).

Figure 3-2: V104n's gyro aiding

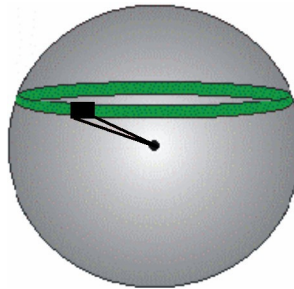

The gyro aiding accurately smoothes the heading output and the rate of turn. It provides an accurate substitute heading for a short period depending on the roll and pitch of the vessel, ideally seeing the system through to reacquisition. The gyro provides an alternate source of heading, accurate to within 1° per minute for up to three minutes, in times of GPS loss for either antenna. If the outage lasts longer than three minutes, the gyro will have drifted too far and the V104n begins outputting null fields in the heading output messages. There is no user control over the timeout period of the gyro.

Calibration, which is set at the factory, is required for the gyro to remove latency from the heading solution as well as provide backup heading when GPS is blocked. The receiver will calibrate itself after running for a while but it may be important to follow the manual calibration instructions if you want to guarantee performance quickly after powering up the receiver.

With the gyro enabled, the gyro is also used to update the post HTAU smoothed heading output from the GPS heading computation. This means that if the HTAU value is increased while gyro aiding is enabled, there will be no lag in heading output due to vehicle maneuvers. Hemisphere GNSS' GPS Technical Reference includes information on setting an appropriate HTAU value for the application.

Time Constants

The V104n incorporates user-configurable time constants that can provide a degree of smoothing to the heading, pitch, rate of turn (ROT), course over ground (COG), and speed measurements. You can adjust these parameters depending on the expected dynamics of the vessel. For example, increasing the time is reasonable if the vessel is very large and is not able to turn quickly or would not pitch quickly. The resulting values would have reduced “noise,” resulting in consistent values with time. However, if the vessel is quick and nimble, increasing this value can create a lag in measurements. Formulas for determining the level of smoothing are located in Hemisphere GNSS’ GPS Technical Reference. If you are unsure on how to set this value, it is best to be conservative and leave it at the default setting.

Note: For heading and rate of turn there is no lag once the gyro is calibrated and enabled.

Rate of Turn (ROT) time constant: The default value of this constant is 2.0 seconds of smoothing. Increasing the time constant increases the level of ROT smoothing.

Course Over Ground (COG) time constant: The default value of this constant is 0.0 seconds of smoothing. Increasing the time constant increases the level of COG smoothing. COG is computed using only the primary GPS antenna and its accuracy depends upon the speed of the vessel (noise is proportional to 1/speed). This value is invalid when the vessel is stationary, as tiny movements due to calculation inaccuracies are not representative of a vessel’s movement.

Speed time constant: The default value of this constant is 0.0 seconds of smoothing. Increasing the time constant increases the level of speed measurement smoothing.

Watchdog

The watchdog is a timer that is controlled by the software that monitors if the heading is lost. The watchdog software is compliant with IEC 60945.

Common Commands and Messages

Table 3-2 below through Table 3-3 provide brief descriptions of common NMEA commands and messages for the V104n. Refer to the Hemisphere GNSS GPS Technical Reference for more detailed information

Table 3-2: Received messages based on a request

PG No. (PGN)	Description	Default Update Rate (msec)	Freq. (Hz)
059392	ISO Acknowledgment Used to acknowledge the status of certain requests addressed to a specific ECU.	On Request	On Request
059904	ISO Request Request the transmission of a specific PGN, addressed or broadcast.	On Request	On Request
060928	ISO Address Claim Used to identify to other ECUs the address claimed by an ECU.	On Request	On Request
126996	Product Information NMEA 2000 database version supported, manufacturer's product code, NMEA 2000 certification level, Load Equivalency number, and other product-specific information.	On Request	On Request
126464	Receive/Transmit PGNs group function The Transmit / Receive PGN List Group type of function is defined by first field. The message will be a Transmit or Receive PGN List group function.	On Request	On Request
129538	GNSS Control Status GNSS common satellite receiver parameter status.	On Request	On Request

PG No. (PGN)	Description	Default Update Rate (msec)	Freq. (Hz)
129545	GNSS RAIM Output Autonomous Integrity Monitoring (RAIM) process. The Integrity field value is based on the parameters set in PGN 129546 GNSS RAIM settings.	On Request	On Request
129546	GNSS RAIM Settings Used to report the control parameters for a GNSS Receiver Autonomous Integrity Monitoring (RAIM) process.	On Request	On Request

Table 3-3: Transmitted messages

PG No. (PGN)	Description	Default Update Rate (msec)	Freq. (Hz)
126992	System Time The purpose of this PGN is twofold: to provide a regular transmission of UTC time, date, and to provide synchronism for measurement data.	1000	1
127250	Vessel Heading Heading sensor value with a flag for True or Magnetic. If the sensor value is Magnetic, the deviation field can be used to produce a Magnetic heading, and the variation field can be used to correct the Magnetic heading to produce a True heading.	100	10
127251	Rate of Turn Rate of change of the Heading.	100	10

PG No. (PGN)	Description	Default Update Rate (msec)	Freq. (Hz)
127257	<p>Attitude</p> <p>Provides a single transmission that describes the position of a vessel relative to both horizontal and vertical planes. This would typically be used for vessel stabilization, vessel control and on-board platform stabilization.</p>	1000	1
127258	<p>Magnetic Variation</p> <p>Message for transmitting variation. The message contains a sequence number to allow synchronization of other messages such as Heading or Course over Ground. The quality of service and age of service are provided to enable recipients to determine an appropriate level of service if multiple transmissions exist.</p>	1000	1
129025	<p>Position, Rapid Update</p> <p>Provides latitude and longitude referenced to WGS84. Being defined as single frame message, as opposed to other PGNs that include latitude and longitude and are defined as fast or multi-packet, this PGN lends itself to being transmitted more frequently without using up excessive bandwidth on the bus for the benefit of receiving equipment that may require rapid position updates.</p>	100	10
129026	<p>COG & SOG, Rapid Update</p> <p>Single frame PGN that provides Course Over Ground (COG) and Speed Over Ground (SOG).</p>	250	4

Chapter 3: Operation

PG No. (PGN)	Description	Default Update Rate (msec)	Freq. (Hz)
129027	<p>Position Delta, High Precision Rapid Update</p> <p>The "Position Delta, High Precision Rapid Update" Parameter Group is intended for applications where very high precision and very fast update rates are needed for position data. This PGN can provide delta position changes down to 1 mm with a delta time period accurate to 5 msec.</p>	100	10
129028	<p>Altitude Delta, High Precision Rapid Update</p> <p>The "Altitude Delta, High Precision Rapid Update" Parameter Group is intended for applications where very high precision and very fast update rates are needed for altitude and Course Over Ground data. This PGN can provide delta altitude changes down to 1 millimeter, a change in direction as small as 0.0057°, and with a delta time period accurate to 5 msec.</p>	100	10
129029	<p>GNSS Position Data</p> <p>Conveys a comprehensive set of Global Navigation Satellite System (GNSS) parameters, including position information.</p>	1000	1
129033	<p>Time & Date</p> <p>Single transmission that provides UTC time, UTC Date, and Local Offset.</p>	1000	1
129539	<p>GNSS DOPs</p> <p>Provides a single transmission containing GNSS status and dilution of precision components (DOP) that indicate the contribution of satellite geometry to the overall position error. There are three DOP parameters reported: horizontal (HDOP), vertical (VDOP), and time (TDOP).</p>	1000	1

PG No. (PGN)	Description	Default Update Rate (msec)	Freq. (Hz)
129540	GNSS Sats in View GNSS information on current satellites in view tagged by sequence ID. Information includes PRN, elevation, azimuth, SNR, defines the number of satellites; defines the satellite number and the information.	1000	1
129542	GNSS Pseudorange Noise Statistics GNSS pseudorange measurement noise statistics can be translated in the position domain in order to give statistical measures of the quality of the position solution. Intended for use with a Receiver Autonomous Integrity Monitoring (RAIM) application	1000	1

Table 3-4: Single Frame packet definition - PGN: EFX (Destination addressable)

MSGIDs	Description
0x0001	N2K, MCODE
0x0002	N2K, PCODE
0x0003	N2K, LOAD
0x0004	N2K, CERT
0x0005	JVERSION
0x0006	N2K, RESET
0x0007	N2K, ADDRESS
0x0008	JDIFF
0x0009	JDIFF, INCLUDE

Table 3-4: Single Frame packet definition - PGN: EFX (Destination addressable)

MSGIDs	Description
0x000A	JMODES
0x000B	JSBASPRN
0x000C	JBAUD,PORTx
0x000	JMASK
0x000E	JATT,TILTAID
0x000F	JATT,TILTCAL
0x0010	JATT,HBIAS
0x0011	JATT,PBIAS
0x0012	JATT,GYROAID
0x0013	JRESET
0x0014	Jl, serial number
0x0015	JRAIM
0x0016	JATT,HIGHMP
0x0017	JAPP
0x0018	JAGE
0x0019	BIN1, stdev residuals
0x00A	RD1
0x001B	JK (read)
0x001C	File Transfer Details
0x001	JWCONF,12
0x001E	GNSS receiver boot loader reply messages
0x001F	Jl, application version

Table 3-4: Single Frame packet definition - PGN: EFX (Destination addressable)

MSGIDs	Description
0x0020	JSYSVER
0x0021	JT
0x0022	JATT,MSEP
0x0023	JATT,CSEP
0x0024	ERROR
0x0025	NMEA 2000 Message Control
0x0026	JNP
0x0027	JSMOOTH
0x0028	JATT,HTAU
0x0029	JATT,HRTAU
0x002A	JATT,COGTAU
0x002B	JATT,SPDTAU
0x002C	JATT,NEGILT
0x002D	JATT,FLIPBRD
0x002E	JATT,LEVEL
0x002F	JATT,MOVEBAS
0x0030	CANMODE
0x0031	GPHEV Heave
0x0032	JSAVE
0x0033	DIAGNOSTICS
0x0034	INTLT Raw Tilt Values

Table 3-5: Multi-Frame Fast Packet definition: PGN: 1EFFF (Destination addressable)

MSGIDs	Description
0x8001	N2K,VERSION
0x8002	JK (write)
0x8003	JPOSOFFSET
0x8004	JVERSION
0x8005	JAUTH
0x8006	File Transfer Data Packet
0x8007	GNSS Boot loader Message
0x8008	Generic GNSS Serial Command
0x8009	RAW data transfer for differential
0x800A	JJ, Extended info
0x800B	N2K,MODEL

Appendix A: Troubleshooting

Appendix A: Troubleshooting

Table A-1 provides troubleshooting for common problems.

Table A-1: Troubleshooting

Symptom	Possible Solution
Receiver fails to power	<ul style="list-style-type: none"> • Check integrity of power cable connectors • Check power input voltage (6 to 36VDC) • Check current restrictions imposed by power source (minimum available should be > 1.0A)
No data from V104n	<ul style="list-style-type: none"> • Check receiver power status to ensure the receiver is powered (an ammeter can be used for this) • Check integrity and connectivity of power and data cable connections
No GPS lock	<ul style="list-style-type: none"> • Verify the V104n has a clear view of the sky • Verify the lock status of GPS satellites
No SBAS lock	<ul style="list-style-type: none"> • Verify the V104n has a clear view of the sky • Verify the lock status of SBAS satellites <p>Note: SBAS lock is only possible if you are in an appropriate SBAS region; currently, there is limited SBAS availability in the southern hemisphere.</p>
No heading or incorrect heading value	<ul style="list-style-type: none"> • Heading is from primary GPS antenna to secondary GPS antenna, so the arrow on the underside of the V104n should be directed to the bow side • Monitor the number of satellites and SNR values for both antennas - at least four satellites should have strong SNR values

Appendix B: Specifications

Table B-1 through Table B-5 provide the V104n's GPS sensor, communication, power, mechanical, and environmental specifications.

Table B-1: GPS sensor specifications

Item	Specification
Receiver type	Vector GPS L1 Compass
Channels	Two 12-channel, parallel tracking (Two 10-channel when tracking SBAS)
SBAS tracking	2-channel, parallel tracking
Update rate	10 Hz standard (position and heading)
Position accuracy	
Single Point ¹	1 m (95%)
SBAS ²	3 m (95%)
Heading accuracy	2° (RMS)
Heave accuracy ³	< 30 cm (RMS)
Pitch/Roll accuracy	2° (RMS)
Rate of turn	90°/s maximum
Cold start	< 60 s typical (no almanac or RTC)
Warm start	< 20 s typical (almanac and RTC)
Hot start	< 1 s typical (almanac, RTC, and position)
Heading fix	< 10 s typical (valid position)
Compass safe distance	30 cm (11.8 in)
Maximum speed	1,850 kph (999 kts)
Maximum altitude	18,288 m (60,000 ft)

Appendix B: Specifications

Table B-2: Communication specifications

Item	Specification
Port	NMEA 2000
Data I/O protocol	NMEA 2000 and CANOpen

Table B-3: Power specifications

Item	Specification
Input voltage	8 to 36 VDC
Power consumption	~ 2.0 W nominal
Current consumption	165 mA @ 12 VDC
Power isolation	Isolated to enclosure
Reverse polarity protection	Yes

Table B-4: Mechanical specifications

Item	Specification
Enclosure	UV resistant, white plastic, Geloy CR7520 (ASA)
Dimensions (not including mount)	25.9 L x 12.9 W x 4.5 H (cm) 10.2 L x 5.1 W x 1.8 H (in)
Dimensions (including mount)	25.9 L x 12.9 W x 12.8 H (cm) 10.2 L x 5.1 W x 5.0 H (in)
Weight (not including mount)	0.42 kg (0.9 lb)
Weight (including mount)	0.51 kg (1.1 lb)

Table B-5: Environmental specifications

Item	Specification
Operating temperature	-30°C to +70°C (-22°F to +158°F)

Table B-5: Environmental specifications (continued)

Item	Specification
Storage temperature	-40°C to +85°C (-40°F to +185°F)
Water and Dust	IP69
Humidity	100% non-condensing
Vibration	IEC 60945
EMC	CE (IEC 60945 Emissions and Immunity) FCC Part 15, Subpart B CISPR22F

¹Depends on multipath environment, number of satellites in view, satellite geometry, no SA, and ionospheric activity.

²Depends on multipath environment, number of satellites in view, SBAS coverage and satellite geometry.

³Based on a 40-second time constant.

Index

A

alarm
 watchdog 29
alignment 11
automatic
 SBAS tracking 25
 tracking 24

C

COGTAU 29
commands (common) 30
common commands and messages 30
communication specifications 43 connect
 to a power source 20
course over ground time constant 29

E

electrical isolation 20
environmental
 considerations 6
 specifications 43
environmental considerations 6

F

flush mount 15

G

GPS
 automatic SBAS tracking 25 automatic
 tracking 24
 operation 24
 overview 24
 receiver performance 24

 reception 6
 sensor specifications 42
gyro aiding 27

H

heave
 accuracy 42
HRTAU 29

L

long sight alignment 11

M

mechanical specifications 43
message (common) 30 mounting
 alignment 11
 environmental considerations 6
 flush mount 15
 GPS reception 6
 location 6
 orientation 9
 parallel orientation 9
 perpendicular orientation 9
 pole mount 17
 VHF interference 7

O

orientation for mounting 9

P

parallel mounting 9
part numbers 3
parts list 3

- perpendicular mounting 9
- pole mount 17
- power
 - connecting to a power source 20
 - considerations 20
 - electrical isolation 20
 - specifications 43

R

- rate of turn (ROT) time constant 29
- receiver performance 24
- RS-232 21

S

- sensor specifications 42
- short site alignment 11
- SPDTAU 29
- specifications
 - communication 43
 - environmental 43
 - GPS sensor 42
 - mechanical 43
 - power 43
- speed time constant 29 supplemental sensors 26

T

- tilt aiding 27
- time constants 29
 - COGTAU 29
 - HRTAU 29
 - SPDTAU 29
- tracking
 - automatic 24
 - automatic SBAS 25
- troubleshooting 40

V

- VHF interference 7

W

- watchdog 29

Index

End User License Agreement

IMPORTANT - This is an agreement (the "**Agreement**") between you, the end purchaser ("**Licensee**") and Hemisphere GNSS Inc. ("**Hemisphere**") which permits Licensee to use the Hemisphere software (the "**Software**") that accompanies this Agreement. This Software may be licensed on a standalone basis or may be embedded in a Product. Please read and ensure that you understand this Agreement before installing or using the Software Update or using a Product.

In this agreement any product that has Software embedded in it at the time of sale to the Licensee shall be referred to as a "**Product**". As well, in this Agreement, the use of a Product shall be deemed to be use of the Software which is embedded in the Product.

BY INSTALLING OR USING THE SOFTWARE UPDATE OR THE PRODUCT, LICENSEE THEREBY AGREES TO BE LEGALLY BOUND BY THE TERMS OF THIS AGREEMENT. IF YOU DO NOT AGREE TO THESE TERMS, (I) DO NOT INSTALL OR USE THE SOFTWARE, AND (II) IF YOU ARE INSTALLING AN UPDATE TO THE SOFTWARE, DO NOT INSTALL THE UPDATE AND PROMPTLY DESTROY IT.

HEMISPHERE PROVIDES LIMITED WARRANTIES IN RELATION TO THE SOFTWARE. AS WELL, THOSE WHO USE THE EMBEDDED SOFTWARE DO SO AT THEIR OWN RISK. YOU SHOULD UNDERSTAND THE IMPORTANCE OF THESE AND OTHER LIMITATIONS SET OUT IN THIS AGREEMENT BEFORE INSTALLING OR USING THE SOFTWARE OR THE PRODUCT.

1. **LICENSE.** Hemisphere hereby grants to Licensee a non-transferable and non-exclusive license to use the Software as embedded in a Product and all Updates (collectively the "**Software**"), solely in binary executable form.
2. **RESTRICTIONS ON USE.** Licensee agrees that Licensee and its employees will not directly or indirectly, in any manner whatsoever:
 - a. install or use more copies of the Software than the number of copies that have been licensed;
 - b. use or install the Software in connection with any product other than the Product the Software was intended to be used or installed on as set out in the documentation that accompanies the Software.
 - c. copy any of the Software or any written materials for any purpose except as part of Licensee's normal backup processes;
 - d. modify or create derivative works based on the Software;
 - e. sub-license, rent, lease, loan or distribute the Software;
 - f. permit any third party to use the Software;
 - g. use or operate Product for the benefit of any third party in any type of service outsourcing, application service, provider service or service bureau capacity;
 - h. reverse engineer, decompile or disassemble the Software or otherwise reduce it to a human perceivable form;
 - i. Assign this Agreement or sell or otherwise transfer the Software to any other party except as part of the sale or transfer of the whole Product.
3. **UPDATES.** At Hemisphere's discretion Hemisphere may make Updates available to Licensee. An update ("**Update**") means any update to the Software that is made available to Licensee including error corrections, enhancements and other modifications. Licensee may access, download and install Updates during the Warranty Period only. All Updates that Licensee downloads, installs or uses shall be deemed to be Software and subject to this Agreement. Hemisphere reserves the right to modify the Product without any obligation to notify, supply or install any improvements or alterations to existing Software.
4. **SUPPORT.** Hemisphere may make available directly or through its authorized dealers telephone and email support for the Software. Contact Hemisphere to find the authorized dealer near you. As well, Hemisphere may make available user and technical documentation regarding the Software. Hemisphere reserves the right to reduce and limit access to such support at any time.
5. **BACKUPS AND RECOVERY.** Licensee shall back-up all data used, created or stored by the Software on a regular basis as necessary to enable proper recovery of the data and related systems and processes in the event of a malfunction in the Software or any loss or corruption of data caused by the Software. Licensee shall assume all risks of loss or damage for any failure to comply with the foregoing.
6. **OWNERSHIP.** Hemisphere and its suppliers own all rights, title and interest in and to the Software and related materials, including all intellectual property rights. The Software is licensed to Licensee, not sold.
7. **TRADEMARKS.** "Hemisphere GNSS", "Crescent", "Eclipse" and the associated logos are trademarks of Hemisphere. Other trademarks are the property of their respective owners. Licensee may not use any of these trademarks without the consent of their respective owners.
8. **LIMITED WARRANTY.** Hemisphere warrants solely to the Licensee, subject to the exclusions and procedures set forth herein below, that for a period of one (1) year from the original date of purchase of the Product in which it is embedded (the "Warranty Period"), the Software, under normal use and maintenance, will conform in all material respects to the documentation provided with the Software and any media will be free of defects in materials and workmanship. For any Update, Hemisphere warrants, for 90 days from performance or delivery, or for the balance of the original Warranty Period, whichever is greater, that the Update, under normal use and maintenance, will conform in all material respects to the documentation provided with the Update and any media will be free of defects in materials and workmanship. Notwithstanding the foregoing, Hemisphere does not warrant that the Software will meet Licensee's requirements or that its operation will be error free.
9. **WARRANTY EXCLUSIONS.** The warranty set forth in Section (8) will not apply to any deficiencies caused by (a) the Product not being used as described in the documentation supplied to Licensee, (b) the Software having been altered, modified or converted in any way by anyone other than Hemisphere approved by Hemisphere, (c) any malfunction of Licensee's equipment or other software, or (d) damage occurring in transit or due to any accident, abuse, misuse, improper installation, lightning (or other electrical discharge) or neglect other than that caused by Hemisphere. Hemisphere GNSS does not warrant or guarantee the precision or accuracy of positions obtained when using the Software (whether standalone or embedded in a Product). The Product and the Software is not intended and should not be used as the primary means of navigation or for use in safety of life applications. The potential position and navigation accuracy obtainable with the Software as stated in the Product or Software documentation serves to provide only an estimate of achievable accuracy based on specifications provided by the US Department of Defense for GPS position and DGPS service provider performance specifications, where applicable.

10. **WARRANTY DISCLAIMER.** EXCEPT AS EXPRESSLY SET OUT IN THIS AGREEMENT, HEMISPHERE MAKES NO REPRESENTATION, WARRANTY OR CONDITION OF ANY KIND TO LICENSEE, WHETHER VERBAL OR WRITTEN AND HEREBY DISCLAIMS ALL REPRESENTATIONS, WARRANTIES AND CONDITIONS OF ANY KIND INCLUDING FITNESS FOR A PARTICULAR PURPOSE, MERCHANTABILITY, ACCURACY, RELIABILITY OR THAT THE USE OF THE SOFTWARE WILL BE UNINTERRUPTED OR ERROR-FREE AND HEREBY DISCLAIMS ALL REPRESENTATIONS, WARRANTIES AND CONDITIONS ARISING AS A RESULT OF CUSTOM, USAGE OR TRADE AND THOSE ARISING UNDER STATUTE.
11. **LIMITS ON WARRANTY DISCLAIMER.** Some jurisdictions do not allow the exclusion of implied warranties or conditions, so some of the above exclusions may not apply to Licensee. In that case, any implied warranties or conditions which would then otherwise arise will be limited in duration to ninety (90) days from the date of the license of the Software or the purchase of the Product. The warranties given herein give Licensee specific legal rights and Licensee may have other rights which may vary from jurisdiction to jurisdiction.
12. **CHANGE TO WARRANTY.** No employee or agent of Hemisphere is authorized to change the warranty provided or the limitation or disclaimer of warranty provisions. All such changes will only be effective if pursuant to a separate agreement signed by senior officers of the respective parties.
13. **WARRANTY CLAIM.** In the event Licensee has a warranty claim Licensee must first check for and install all Updates that are made available. The warranty will not otherwise be honored. Proof of purchase may be required. Hemisphere does not honor claims asserted after the end of the Warranty Period.
14. **LICENSEE REMEDIES.** In all cases which involve a failure of the Software to conform in any material respect to the documentation during the Warranty Period or a breach of a warranty, Hemisphere's sole obligation and liability, and Licensee's sole and exclusive remedy, is for Hemisphere, at Hemisphere's option, to (a) repair the Software, (b) replace the Software with software conforming to the documentation, or (c) if Hemisphere is unable, on a reasonable commercial basis, to repair the Software or to replace the Software with conforming software within ninety (90) days, to terminate this Agreement and thereafter Licensee shall cease using the Software. Hemisphere will also issue a refund for the price paid by Licensee less an amount on account of amortization, calculated on a straight-line basis over a deemed useful life of three (3) years.
15. **LIMITATION OF LIABILITY.** IN NO EVENT WILL HEMISPHERE BE LIABLE TO LICENSEE FOR ANY INCIDENTAL, CONSEQUENTIAL, SPECIAL OR INDIRECT DAMAGES INCLUDING ARISING IN RELATION TO ANY LOSS OF DATA, INCOME, REVENUE, GOODWILL OR ANTICIPATED SAVINGS EVEN IF HEMISPHERE HAS BEEN INFORMED OF THE POSSIBILITY OF SUCH LOSS OR DAMAGE. FURTHER, IN NO EVENT WILL HEMISPHERE'S TOTAL CUMULATIVE LIABILITY HEREUNDER, FROM ALL CAUSES OF ACTION OF ANY KIND, EXCEED THE TOTAL AMOUNT PAID BY LICENSEE TO HEMISPHERE TO PURCHASE THE PRODUCT. THIS LIMITATION AND EXCLUSION APPLIES IRRESPECTIVE OF THE CAUSE OF ACTION, INCLUDING BUT NOT LIMITED TO BREACH OF CONTRACT, NEGLIGENCE, STRICT LIABILITY, TORT, BREACH OF WARRANTY, MISREPRESENTATION OR ANY OTHER LEGAL THEORY AND WILL SURVIVE A FUNDAMENTAL BREACH.
16. **LIMITS ON LIMITATION OF LIABILITY.** Some jurisdictions do not allow for the limitation or exclusion of liability for incidental or consequential damages, so the above limitation or exclusion may not apply to Licensee and Licensee may also have other legal rights which may vary from jurisdiction to jurisdiction.
17. **BASIS OF BARGAIN.** Licensee agrees and acknowledges that Hemisphere has set its prices and the parties have entered into this Agreement in reliance on the limited warranties, warranty disclaimers and limitations of liability set forth herein, that the same reflect an agreed-to allocation of risk between the parties (including the risk that a remedy may fail of its essential purpose and cause consequential loss), and that the same forms an essential basis of the bargain between the parties. Licensee agrees and acknowledges that Hemisphere would not have been able to sell the Product at the amount charged on an economic basis without such limitations.
18. **PROPRIETARY RIGHTS INDEMNITY.** Hemisphere shall indemnify, defend and hold harmless Licensee from and against any and all actions, claims, demands, proceedings, liabilities, direct damages, judgments, settlements, fines, penalties, costs and expenses, including royalties and attorneys' fees and related costs, in connection with or arising out of any actual infringement of any third party patent, copyright or other intellectual property right by the Software or by its use, in accordance with this Agreement and documentation, PROVIDED THAT: (a) Hemisphere has the right to assume full control over any action, claim, demand or proceeding, (b) Licensee shall promptly notify Hemisphere of any such action, claim, demand, or proceeding, and (c) Licensee shall give Hemisphere such reasonable assistance and tangible material as is reasonably available to Licensee for the defense of the action, claim, demand or proceeding. Licensee shall not settle or compromise any of same for which Hemisphere has agreed to assume responsibility without Hemisphere's prior written consent. Licensee may, at its sole cost and expense, retain separate counsel from the counsel utilized or retained by Hemisphere.
19. **INFRINGEMENT.** If use of the Software may be enjoined due to a claim of infringement by a third party then, at its sole discretion and expense, Hemisphere may do one of the following: (a) negotiate a license or other agreement so that the Product is no longer subject to such a potential claim, (b) modify the Product so that it becomes non-infringing, provided such modification can be accomplished without materially affecting the performance and functionality of the Product, (c) replace the Software, or the Product, with non-infringing software, or product, of equal or better performance and quality, or (d) if none of the foregoing can be done on a commercially reasonable basis, terminate this license and Licensee shall stop using the Product and Hemisphere shall refund the price paid by Licensee less an amount on account of amortization, calculated on a straight-line basis over a deemed useful life of three (3) years.
The foregoing sets out the entire liability of Hemisphere and the sole obligations of Hemisphere to Licensee in respect of any claim that the Software or its use infringes any third party rights.
20. **INDEMNIFICATION.** Except in relation to an infringement action, Licensee shall indemnify and hold Hemisphere harmless from any and all claims, damages, losses, liabilities, costs and expenses (including reasonable fees of lawyers and other professionals) arising out of or in connection with Licensee's use of the Product, whether direct or indirect, including without limiting the foregoing, loss of data, loss of profit or business interruption.
21. **TERMINATION.** Licensee may terminate this Agreement at any time without cause. Hemisphere may terminate this Agreement on 30 days notice to Licensee if Licensee fails to materially comply with each provision of this Agreement unless such default is cured within the 30 days. Any such termination by a party shall be in addition to and without prejudice to such rights and remedies as may be available, including injunction and other equitable remedies. Upon receipt by Licensee of written notice of termination from

Hemisphere or termination by Licensee, Licensee shall at the end of any notice period (a) cease using the Software; and (b) return to Hemisphere (or destroy and provide a certificate of a Senior Officer attesting to such destruction) the Software and all related material and any magnetic or optical media provided to Licensee. The provisions of Sections 6), 7), 8), 9), 10), 15), 21), 26) and 27) herein shall survive the expiration or termination of this Agreement for any reason.

22. **EXPORT RESTRICTIONS.** Licensee agrees that Licensee will comply with all export control legislation of Canada, the United States, Australia and any other applicable country's laws and regulations, whether under the Arms Export Control Act, the International Traffic in Arms Regulations, the Export Administration Regulations, the regulations of the United States Departments of Commerce, State, and Treasury, or otherwise as well as the export control legislation of all other countries.
23. **PRODUCT COMPONENTS.** The Product may contain third party components. Those third party components may be subject to additional terms and conditions. Licensee is required to agree to those terms and conditions in order to use the Product.
24. **FORCE MAJEURE EVENT.** Neither party will have the right to claim damages as a result of the other's inability to perform or any delay in performance due to unforeseeable circumstances beyond its reasonable control, such as labor disputes, strikes, lockouts, war, riot, insurrection, epidemic, Internet virus attack, Internet failure, supplier failure, act of God, or governmental action not the fault of the non-performing party.
25. **FORUM FOR DISPUTES.** The parties agree that the courts located in Calgary, Alberta, Canada and the courts of appeal there from will have exclusive jurisdiction to resolve any disputes between Licensee and Hemisphere concerning this Agreement or Licensee's use or inability to use the Software and the parties hereby irrevocably agree to attorn to the jurisdiction of those courts. Notwithstanding the foregoing, either party may apply to any court of competent jurisdiction for injunctive relief.
26. **APPLICABLE LAW.** This Agreement shall be governed by the laws of the Province of Alberta, Canada, exclusive of any of its choice of law and conflicts of law jurisprudence.
27. **CISG.** The United Nations Convention on Contracts for the International Sale of Goods will not apply to this Agreement or any transaction hereunder.
28. **GENERAL.** This is the entire agreement between Licensee and Hemisphere relating to the Product and Licensee's use of the same, and supersedes all prior, collateral or contemporaneous oral or written representations, warranties or agreements regarding the same. No amendment to or modification of this Agreement will be binding unless in writing and signed by duly authorized representatives of the parties. Any and all terms and conditions set out in any correspondence between the parties or set out in a purchase order which are different from or in addition to the terms and conditions set forth herein, shall have no application and no written notice of same shall be required. In the event that one or more of the provisions of this Agreement is found to be illegal or unenforceable, this Agreement shall not be rendered inoperative but the remaining provisions shall continue in full force and effect.
- 29.

Warranty Notice

COVERED PRODUCTS: This warranty covers all products manufactured by Hemisphere GNSS and purchased by the end purchaser (the "Products"), unless otherwise specifically and expressly agreed in writing by Hemisphere GNSS.

LIMITED WARRANTY: Hemisphere GNSS warrants solely to the end purchaser of the Products, subject to the exclusions and procedures set forth below, that the Products sold to such end purchaser and its internal components shall be free, under normal use and maintenance, from defects in materials, and workmanship and will substantially conform to Hemisphere GNSS' applicable specifications for the Product, for a period of 12 months from delivery of such Product to such end purchaser (the "Warranty Period"). Repairs and replacement components for the Products are warranted, subject to the exclusions and procedures set forth below, to be free, under normal use and maintenance, from defects in material and workmanship, and will substantially conform to Hemisphere GNSS' applicable specifications for the Product, for 90 days from performance or delivery, or for the balance of the original Warranty Period, whichever is greater.

EXCLUSION OF ALL OTHER WARRANTIES. The LIMITED WARRANTY shall apply only if the Product is properly and correctly installed, configured, interfaced, maintained, stored, and operated in accordance with Hemisphere GNSS' relevant User's Manual and Specifications, AND the Product is not modified or misused. The Product is provided "AS IS" and the implied warranties of MERCHANTABILITY and FITNESS FOR A PARTICULAR PURPOSE and ALL OTHER WARRANTIES, express, implied or arising by statute, by course of dealing or by trade usage, in connection with the design, sale, installation, service or use of any products or any component thereof, are EXCLUDED from this transaction and shall not apply to the Product. The LIMITED WARRANTY is IN LIEU OF any other warranty, express or implied, including but not limited to, any warranty of MERCHANTABILITY or FITNESS FOR A PARTICULAR PURPOSE, title, and non-infringement.

LIMITATION OF REMEDIES. The purchaser's EXCLUSIVE REMEDY against Hemisphere GNSS shall be, at Hemisphere GNSS' option, the repair or replacement of any defective Product or components thereof. The purchaser shall notify Hemisphere GNSS or a Hemisphere GNSS' approved service center immediately of any defect. Repairs shall be made through a Hemisphere GNSS approved service center only. Repair, modification or service of Hemisphere GNSS products by any party other than a Hemisphere GNSS approved service center shall render this warranty null and void. The remedy in this paragraph shall only be applied in the event that the Product is properly and correctly installed, configured, interfaced, maintained, stored, and operated in accordance with Hemisphere GNSS' relevant User's Manual and Specifications, AND the Product is not modified or misused. NO OTHER REMEDY (INCLUDING, BUT NOT LIMITED TO, SPECIAL, INDIRECT, INCIDENTAL, CONSEQUENTIAL OR CONTINGENT DAMAGES FOR LOST PROFITS, LOST SALES, INJURY TO PERSON OR PROPERTY, OR ANY OTHER INCIDENTAL OR CONSEQUENTIAL LOSS) SHALL BE AVAILABLE TO PURCHASER, even if Hemisphere GNSS has been advised of the possibility of such damages. Without limiting the foregoing, Hemisphere GNSS shall not be liable for any damages of any kind resulting from installation, use, quality, performance or accuracy of any Product.

HEMISPHERE IS NOT RESPONSIBLE FOR PURCHASER'S NEGLIGENCE OR UNAUTHORIZED USES OF THE PRODUCT. IN NO EVENT SHALL Hemisphere GNSS BE IN ANY WAY RESPONSIBLE FOR ANY DAMAGES RESULTING FROM PURCHASER'S OWN NEGLIGENCE, OR FROM OPERATION OF THE PRODUCT IN ANY WAY OTHER THAN AS SPECIFIED IN Hemisphere GNSS'S RELEVANT USER'S MANUAL AND SPECIFICATIONS. Hemisphere GNSS is NOT RESPONSIBLE for defects or performance problems resulting from (1) misuse, abuse, improper installation, neglect of Product; (2) the utilization of the Product with hardware or software products, information, data, systems, interfaces or devices not made, supplied or specified by Hemisphere GNSS; (3) the operation of the Product under any specification other than, or in addition to, the specifications set forth in Hemisphere GNSS' relevant User's Manual and Specifications; (4) damage caused by accident or natural events, such as lightning (or other electrical discharge) or fresh/salt water immersion of Product; (5) damage occurring in transit; (6) normal wear and tear; or (7) the operation or failure of operation of any satellite-based position system or differential correction service; or the availability or performance of any satellite-based position signal or differential correction signal.

THE PURCHASER IS RESPONSIBLE FOR OPERATING THE VEHICLE SAFELY. The purchaser is solely responsible for the safe operation of the vehicle used in connection with the Product, and for maintaining proper system control settings. UNSAFE DRIVING OR SYSTEM CONTROL SETTINGS CAN RESULT IN PROPERTY DAMAGE, INJURY, OR DEATH. The purchaser is solely responsible for his/her safety and for the safety of others. The purchaser is solely responsible for maintaining control of the automated steering system at all times. THE PURCHASER IS SOLELY RESPONSIBLE FOR ENSURING THE PRODUCT IS PROPERLY AND CORRECTLY INSTALLED, CONFIGURED, INTERFACED, MAINTAINED, STORED, AND OPERATED IN ACCORDANCE WITH Hemisphere GNSS'S RELEVANT USER'S MANUAL AND SPECIFICATIONS. Hemisphere GNSS does not warrant or guarantee the position and navigation precision or accuracy obtained when using Products. Products are not intended for primary navigation or for use in safety of life applications. The potential accuracy of Products as stated in Hemisphere GNSS literature and/or Product specifications serves to provide only an estimate of achievable accuracy based on performance specifications provided by the satellite service operator (i.e. US Department of Defense in the case of GPS) and differential correction service provider. Hemisphere GNSS reserves the right to modify Products without any obligation to notify, supply or install any improvements or alterations to existing Products.

GOVERNING LAW. This agreement and any disputes relating to, concerning or based upon the Product shall be governed by and interpreted in accordance with the laws of the State of Arizona.

OBTAINING WARRANTY SERVICE. In order to obtain warranty service, the end purchaser must bring the Product to a Hemisphere GNSS approved service center along with the end purchaser's proof of purchase. Hemisphere GNSS does not warrant claims asserted after the end of the warranty period. For any questions regarding warranty service or to obtain information regarding the location of any of Hemisphere GNSS approved service center, contact Hemisphere GNSS at the following address:

Hemisphere GNSS
8444 N. 90th Street, Suite 120
Scottsdale, AZ 85258
Phone: 480-348-6380 Fax: 480-270-5070
techsupport@hemispheregnss.com
www.hemispheregnss.com



Hemisphere GNSS Inc.
8515 E. Anderson Drive, Suite A
Scottsdale, AZ 85255, USA

Phone: +1 480 348 6380.
Fax: +1 480 270 5070.
precision@hgnss.com
www.hgnss.com

