

# OWNERS MANUAL

**Model No.  
45-0265**

**CAUTION:**  
Read Rules for  
Safe Operation  
and Instructions  
Carefully

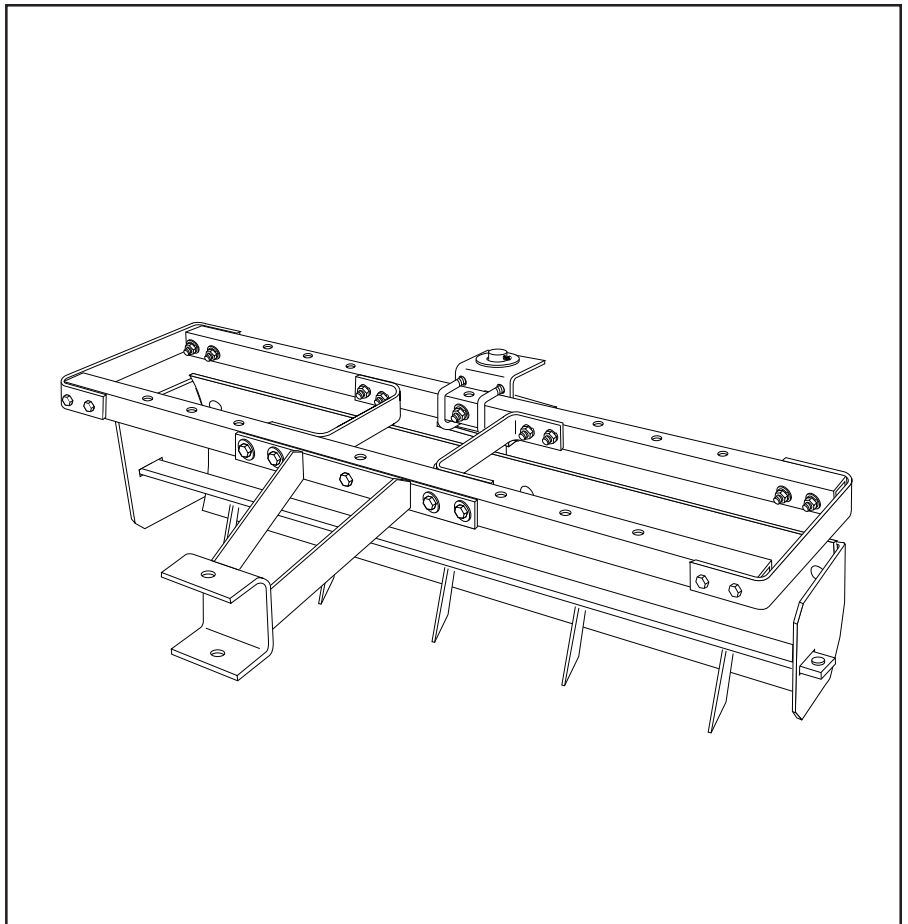

## **BOX SCRAPER/ GRADER BLADE** (SLEEVE HITCH)

- Assembly
- Operation
- Maintenance
- Parts

## SAFETY RULES

Any power equipment can cause injury if operated improperly or if the user does not understand how to operate the equipment. Exercise caution at all times when using power equipment.

1. Read this owners manual and your vehicle and sleeve hitch owners manuals before using this blade.
2. Do not allow children to operate the vehicle or blade.
3. Do not allow adults to operate the vehicle or blade without proper instructions.
4. Do not allow anyone to ride on the blade.
5. Before lowering and operating the blade, be sure no one is near the area of operation.
6. Lower the blade when leaving vehicle unattended.
7. Vehicle braking and stability may be affected with the attachment of this blade. Drive slowly with blade in transport position. **Stay off of steep slopes.**
8. Stop and inspect for damage after striking an object. Repair any damage before continuing operation.
9. Keep all nuts and bolts tight and be sure the equipment is in safe operating condition.
10. Always lock the tractor lift handle down when installing or removing the blade from sleeve hitch.



Look for this symbol to point out important safety precautions. It means--**Attention!! Become alert!!** Your safety is involved.

## ASSEMBLY

### TOOLS REQUIRED FOR ASSEMBLY

- (1) 1/2" Wrench
- (2) 9/16" Wrenches
- (1) Pliers

Refer to illustration on page 3 and full size hardware chart on back page. Place a 3/8" flat washer under any bolt head or lock washer that would otherwise tighten directly against a frame tube or the hitch assembly.

1. Assemble both end plates to the blade using four 5/16" x 1" carriage bolts, 5/16" lock washers and 5/16" hex nuts. **Do not tighten yet.**
2. Assemble the scarifier bar through the slots in the end plates. Secure the bar with two 3/8" x 3/4" clevis pins and two 3/32" hairpin cotters (small). **Tighten** the four bolts which fasten the end plates to the blade.
3. Assemble the pivot reinforcement bracket assembly to the blade using four 3/8" x 1" carriage bolts, 3/8" lock washers and 3/8" hex nuts. **Tighten.**
4. Assemble the hitch assembly, a frame tube and two middle frame braces together using five 3/8" x 2-1/2" hex bolts, 3/8" lock washers, 3/8" flat washers and 3/8" hex nuts. **Do not tighten yet.**
5. Assemble the second frame tube to the middle frame braces using four 3/8" x 2-1/2" hex bolts, 3/8" flat washers, 3/8" lock washers and 3/8" hex nuts. **Do not tighten yet.**
6. Assemble the frame end braces over the ends of the frame tubes using eight 3/8" x 2-1/2" hex bolts, 3/8" flat washers, 3/8" lock washers and 3/8" hex nuts. **Tighten all loose bolts at this time.**

7. Assemble the clevis bracket to the frame using two U-bolts, one 3/8" x 2-1/2" hex bolt, one 3/8" flat washer, five 3/8" lock washers and five 3/8" hex nuts. **Tighten** so that clevis bracket is straight with frame.
8. Assemble the frame to the blade by sliding the clevis bracket down onto the pivot rod. Fasten the clevis bracket onto the pivot rod with the special washer and a 3/16" x 2" cotter pin. Place the pivot lock pin down through the holes in the clevis bracket and pivot plate and secure the pin with a 1/8" hairpin cotter (large).

## ATTACHING BLADE TO TRACTOR



**CAUTION:** Lock tractor lift handle in down position when attaching or removing blade from sleeve hitch.

Refer to your sleeve hitch owners manual.

1. Attach the blade to the sleeve hitch on your tractor using the sleeve hitch pin.
2. Tighten the two stabilizer bolts and jam nuts to eliminate looseness in the hook-up.
3. Adjust the sleeve hitch so that the blade is free to go below ground level but can still be raised a minimum of 5" above ground for transport.
4. The stabilizer bolts and jam nuts should be loosened before removing the blade from the sleeve hitch.

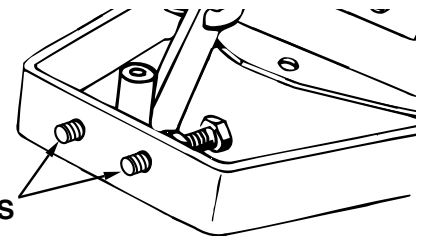

STABILIZER BOLTS

TRACTOR SLEEVE HITCH

## OPERATION

The box scraper/grader blade may be used for scraping and leveling of gravel and loose or lightly compacted dirt, for back filling and for snow removal. For improved traction use wheel weights and/or tire chains.

1. To pivot the blade, raise the sleeve hitch so that the blade is off the ground. Remove the pivot lock pin to rotate the blade to one of six settings.
2. For back filling or removing snow, the blade position may be reversed 180 degrees and the scarifier bar and the box ends removed from the blade. Do not back blade into piles of snow or dirt at high speed.
3. Do not remove the scarifier bar if the box ends are to remain attached to the blade. To place the scarifier in a non-working position, turn it upside down and re-attach to the box ends with the clevis pins.
4. Drive the tractor at a speed which fits conditions and the type of work being performed. When leveling with the blade, a slower speed will allow loose material to be more evenly deposited in low spots.

## MAINTENANCE/STORAGE

1. Check for loose bolts after each use.
2. Rotate the blade top to bottom when wear along bottom edge has become substantial.
3. Remove all dirt and rust and touch up with paint before storing.
4. Store inside a dry area.

# REPAIR PARTS FOR MODEL 45-0265 - BOX SCRAPER/GRADER BLADE

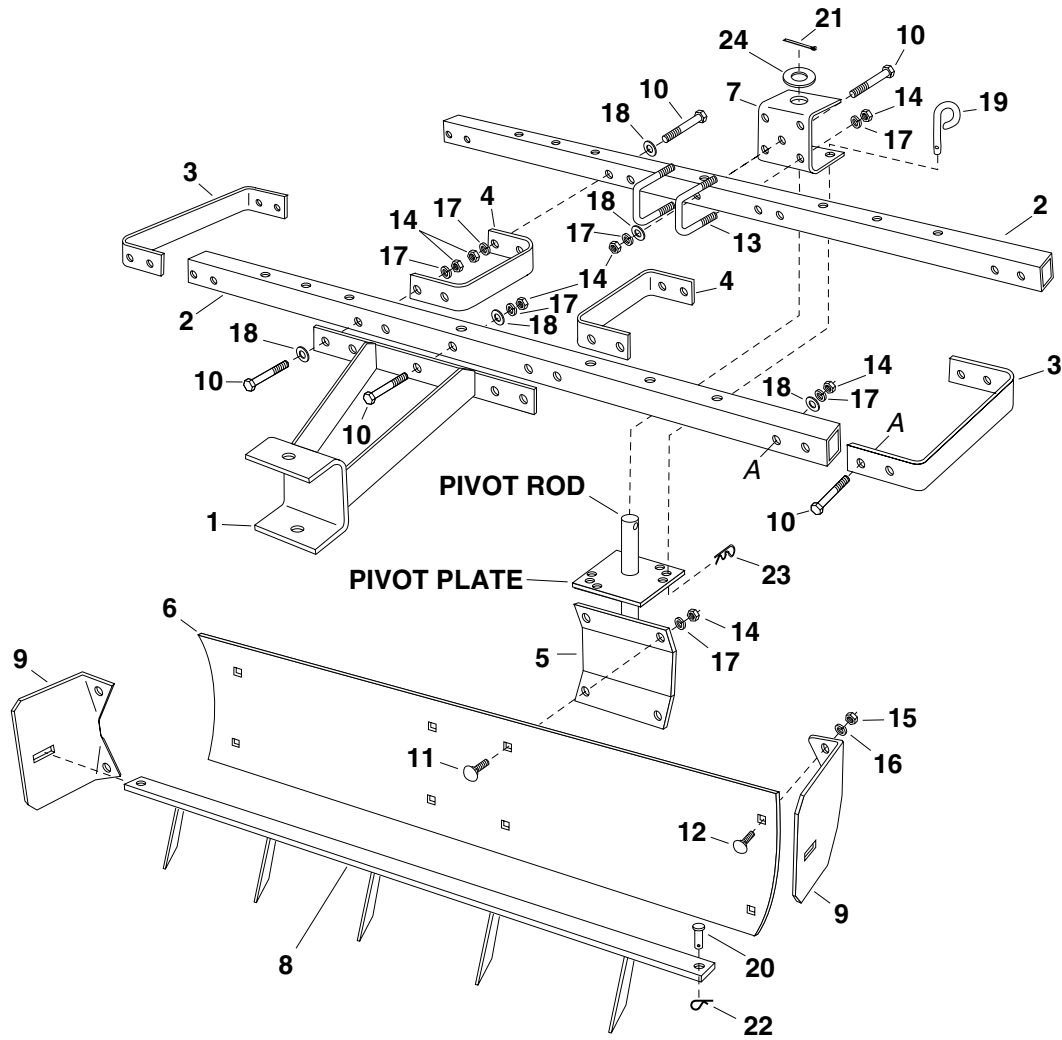

## PARTS LIST FOR MODEL 45-0265 - BOX SCRAPER/GRADER BLADE

REF. NO.	PART NO.	QTY.	DESCRIPTION	REF. NO.	PART NO.	QTY.	DESCRIPTION
1	63656	1	Hitch Assembly	13	46853	2	U-Bolt, 3/8-16
2	46848	2	Frame Tube	14	43015	26	Hex Nut, 3/8-16 Thread
3	24223	2	Frame Brace (End)	15	43083	4	Hex Nut, 5/16-18 Thread
4	24224	2	Frame Brace (Middle)	16	43086	4	Lock Washer, 5/16"
5	63506	1	Pivot Reinforcement Bracket Assembly	17	43003	26	Lock Washer, 3/8"
6	24233	1	Blade	18	43070	18	Washer, 3/8" Std. Wrt.
7	24231	1	Clevis Bracket	19	43038	1	Pivot Lock Pin
8	63507	1	Scarfier Bar (Assembly)	20	44044	2	Clevis Pin, 3/8" x 3/4" Lg.
9	24237	2	Box End Plate	21	46855	1	Cotter Pin, 3/16" x 2" Lg.
10	43432	18	Hex Bolt, 3/8-16 x 2-1/2" Lg.	22	43055	2	Hairpin Cotter, 3/32" #3
11	43350	4	Carriage Bolt, 3/8-16 x 1" Lg.	23	43343	1	Hairpin Cotter, 1/8" #4
12	44326	4	Carriage Bolt, 5/16-18 x 1" Lg.	24	23336	1	Washer, Special
					47056	1	Owners Manual

# FULL SIZE HARDWARE CHART

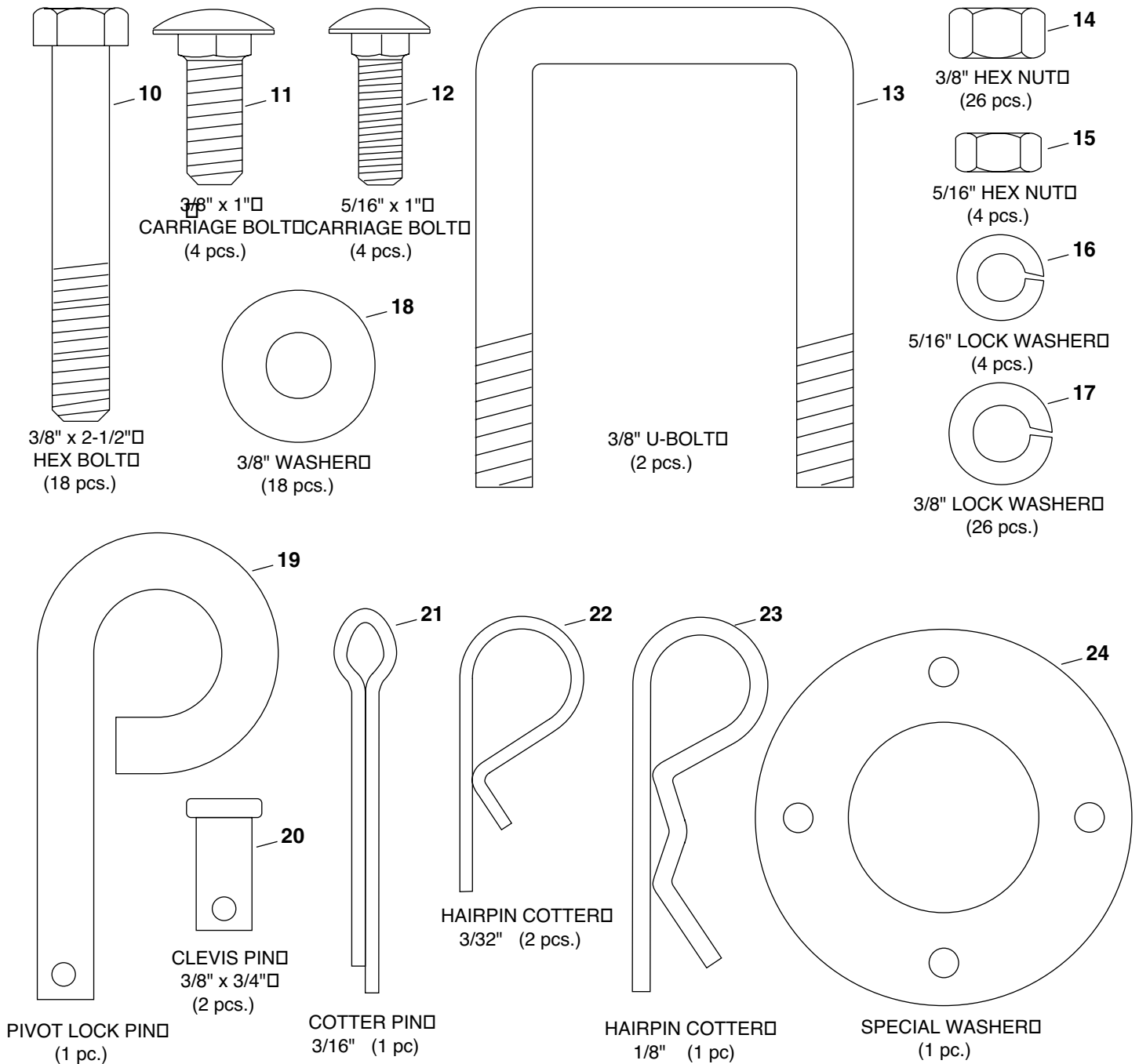

**REPAIR PARTS**  
 303 West Raymond  
 Sullivan, IL. 61951  
 217-728-8388  
 www.agri-fab.com