BlueNRG-1, BlueNRG-2 development kits

Introduction

The BlueNRG-1 and BlueNRG-2 devices are low power Bluetooth Low Energy (BLE) systems-on-chip that are compliant with the Bluetooth® specification and support master, slave and simultaneous master-and-slave roles. BlueNRG-2 also supports the Bluetooth Low Energy data length extension feature.

The following BlueNRG-1, BlueNRG-2 kits are available:

1. BlueNRG-1 development platforms (order code: STEVAL-IDB007V1⁽¹⁾, STEVAL-IDB007V2)
 2. BlueNRG-2 development platforms (order code: STEVAL-IDB008V1⁽¹⁾, STEVAL-IDB008V2, STEVAL-IDB009V1, STEVAL-IDB008V1M)
1. *This board is no longer available for purchase*

The development platforms feature hardware resources for a wide range of application scenarios: sensor data (accelerometer, pressure and temperature sensor), remote control interfaces (buttons and LEDs) and debug message management through USB virtual COM. Three power options are available (USB only, battery only and external power supply plus USB) for high application development and testing flexibility.

RELATED LINKS

The document content is also valid for the BlueNRG-1 STEVAL-IDB007V1M evaluation platform based on the SPBTLE-1S module with 32 MHz HS crystal.

1 Development platforms

Figure 1. STEVAL-IDB007V1 development platform

This item is no longer available for sale



Figure 2. STEVAL-IDB007V2 development platform

based on BlueNRG-1 SoC



Figure 3. STEVAL-IDB008V1 development platform

based on BlueNRG-2 SoC



Figure 4. STEVAL-IDB008V2 development platform

based on BlueNRG-2 SoC



Figure 5. STEVAL-IDB009V1 development platform

based on BlueNRG-2 SoC in QFN48 package



Figure 6. STEVAL-IDB008V1M development platform

based on BlueNRG-M2SA module with embedded BlueNRG-2 SoC



2 Getting started

2.1 Kit contents

The STEVAL-IDB007Vx/STEVAL-IDB008Vx kits include respectively:

- a [BlueNRG-132](#) (QFN32 package)/[BlueNRG-232](#) (QFN32 package) development platform
- a 2.4 GHz Bluetooth antenna
- a USB cable

The STEVAL-IDB009Vx kit includes:

- a [BlueNRG-248](#) (QFN48 package) development platform
- a 2.4 GHz Bluetooth antenna
- a USB cable

The STEVAL-IDB008V1M kit includes:

- a [BlueNRG-M2SA](#) certified module based on the BlueNRG-2 Bluetooth low energy system-on-chip
- a USB cable

2.2 System requirements

The [BlueNRG-1](#), [BlueNRG-2](#) Navigator and Radio Init Parameters Wizard PC applications require:

- PC with Intel® or AMD® processor running Windows 7/10
- At least 128 MB of RAM
- USB ports
- At least 40 MB of available hard disk space
- Adobe Acrobat Reader 6.0 or later

2.3 BlueNRG-1_2 development kit setup

The following [BlueNRG-1](#), [BlueNRG-2](#) DK software packages are available: BlueNRG-1_2 DK SW package for BlueNRG-1, BlueNRG-2 BLE stack v2.x family ([STSW-BLUENRG1-DK](#)).

After downloading the selected software package ([STSW-BLUENRG1-DK](#)) from www.st.com, extract `en.stsw-bluenrg1-dk.zip` contents to a temporary directory, launch `BlueNRG-1_2-DK-x.x.x-Setup.exe` and follow the on-screen instructions.

Note: [EWARM Compiler 8.40.1](#) or later, [Keil MDK-ARM v5.27](#) or later and [Atollic-True Studio v8.1.0](#) are required for building the related `BlueNRG1_2_DK_x.x.x` demonstration applications.

3 Hardware description

3.1 STEVAL-IDB007Vx/STEVAL-IDB008Vx/STEVAL-IDB009Vx board overview

The BlueNRG-1/BlueNRG-2 devices in the STEVAL-IDB007Vx/STEVAL-IDB008Vx/STEVAL-IDB009Vx development kits lets you experiment with BlueNRG-1/BlueNRG-2 system on chip functions. They feature:

- Bluetooth® Low Energy (BLE) board based on the BlueNRG-1/BlueNRG-2 Bluetooth low energy system on chip
- Associated development kit SW package including firmware and documentation
- Up to +8 dBm available output power (at antenna connector)
- Excellent receiver sensitivity (-88 dBm)
- Very low power consumption: 7.7 mA RX and 8.3 mA TX at -2 dBm
- Bluetooth® low energy compliant, supports master, slave and simultaneous master-and-slave roles
- Integrated balun which integrates a matching network and harmonics filter (only on STEVAL-IDB007Vx/STEVAL-IDB008Vx)
- Discrete matching network on STEVAL-IDB009V1
- BlueNRG-M2SA certified module based on the BlueNRG-2 Bluetooth LE SoC on STEVAL-IDB008V1M
- SMA connector for antenna or measuring equipment (not available on STEVAL-IDB007V1M/8V1M)
- 3 user LEDs
- 2 user buttons
- 3D digital accelerometer and 3D digital gyroscope
- MEMS pressure sensor with embedded temperature sensor
- Battery holder
- JTAG debug connector
- USB to serial bridge for providing I/O channel with the BlueNRG-1/BlueNRG-2 device
- Jumper for measuring current for BlueNRG-1/BlueNRG-2 only
- RoHS compliant

The following figure and table describe physical sections of the board.

Figure 7. STEVAL-IDB007Vx board components

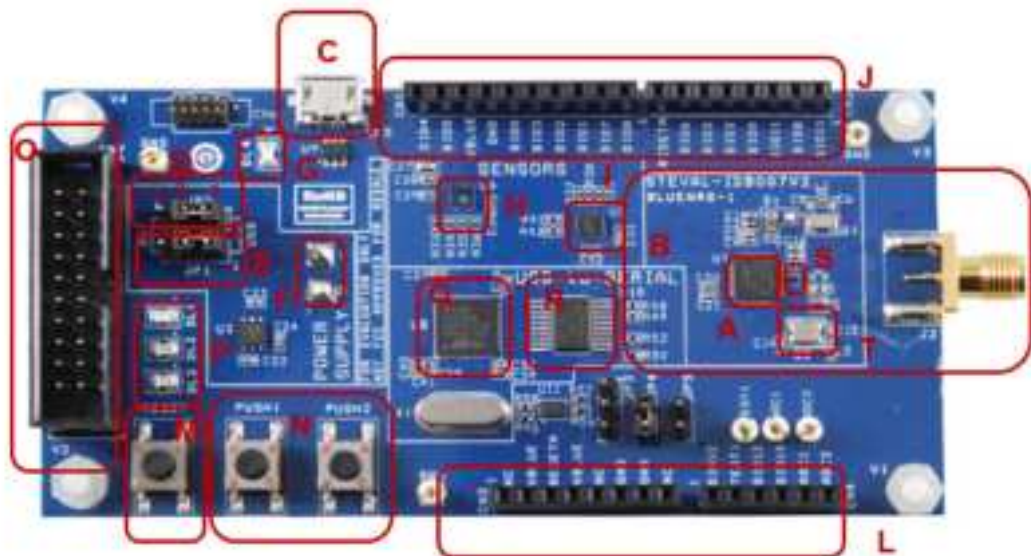

Figure 8. STEVAL-IDB008Vx board components

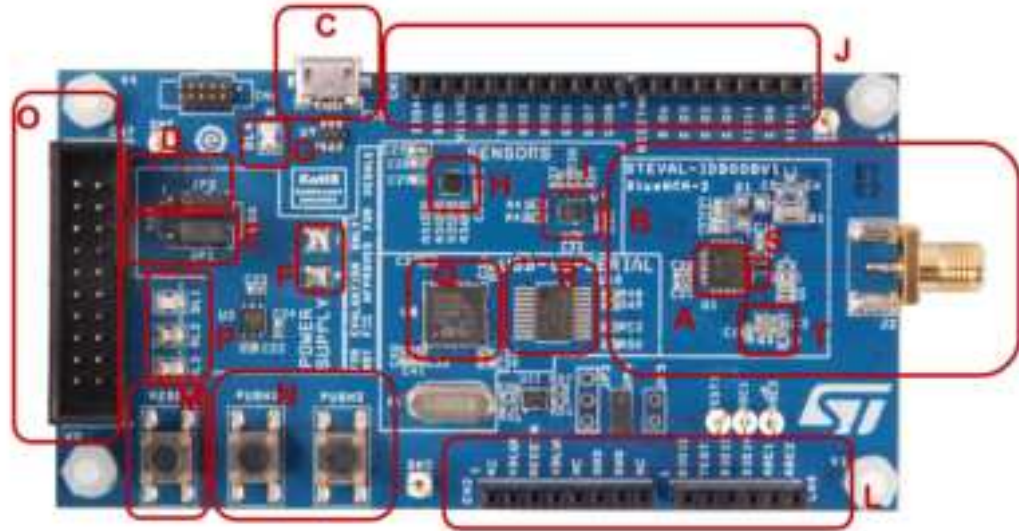

Figure 9. STEVAL-IDB009V1 board components

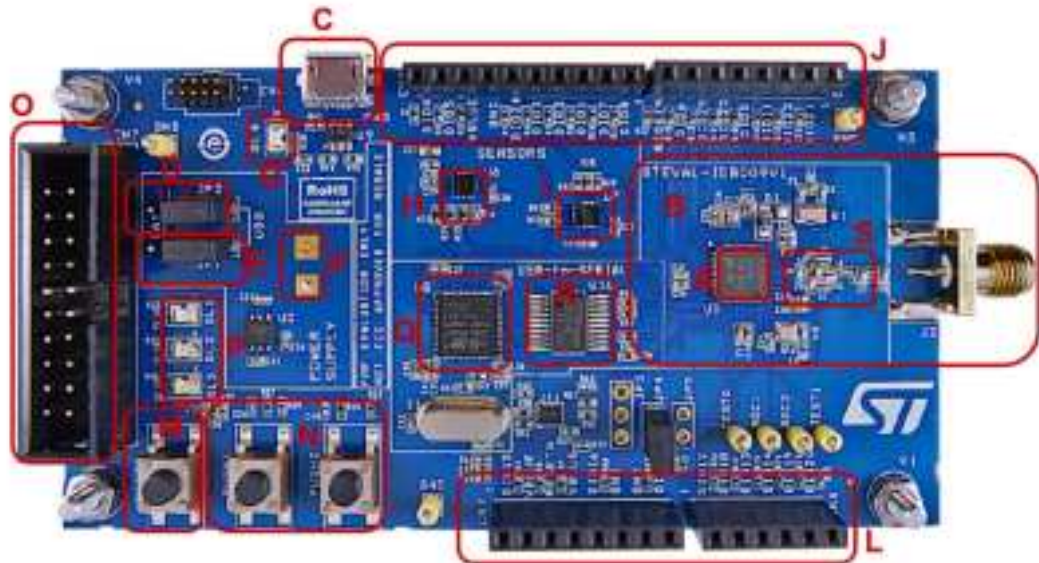

Table 1. STEVAL-IDB007Vx/STEVAL-IDB008Vx/STEVAL-IDB009Vx board component descriptions

Region	Description
A ⁽¹⁾	BlueNRG-132 SoC on STEVAL-IDB007Vx BlueNRG-232 SoC on STEVAL-IDB008Vx BlueNRG-248 SoC on STEVAL-IDB009Vx
C	Micro USB connector for power supply and I/O
O	JTAG connector
M	RESET button
N	Two USER buttons

Region	Description
H	LPS25HB MEMS pressure sensor with embedded temperature
I	LSM6DS3 3D digital accelerometer and 3D digital gyroscope
G	PWR LED
P	Three user LEDs
Back of the PCB	Battery holder for two AAA batteries
J, L	Two rows of Arduino-compliant connectors
S	Integrated balun with matching network and harmonics filter (BALF-NRG-01D3 on STEVAL-IDB007V1/ STEVAL-IDB008V1 and BALF-NRG-02D3 on STEVAL-IDB007V2/STEVAL-IDB008V2). Discrete matching network on STEVAL-IDB009V1.
Q	STM32L151CUB6 48-pin microcontroller (USB to serial bridge for I/O channel to PC communication) ⁽²⁾
R	ST2378E level translator to adapt voltage level between STM32 and BlueNRG-1
T	16 MHz High Speed Crystal on STEVAL-IDB007Vx 32 MHz High Speed Crystal on STEVAL-IDB008Vx, STEVAL-IDB009Vx, STEVAL-IDB009Vx, STEVAL-IDB007V1M/8V1M

On STEVAL-IDB008V1M, region A contains the BlueNRG-M2SA module

On STEVAL-IDB007V1M, region A contains the SPBTLE-1S module

2. STM32 is not intended to be programmed by users

3.2 BlueNRG-1, BlueNRG-2 SoC connections

The BlueNRG-132, BlueNRG-232 very low power Bluetooth low energy (BLE) single-mode system on chip (Figure 7. STEVAL-IDB007Vx board components – region A /Figure 8. STEVAL-IDB008Vx board components - region A) have respectively 160 KB, 256 KB of Flash, 24 KB of RAM, a 32-bit core ARM Cortex-M0 processor and several peripherals (ADC, 15 GPIOs, I²C, SPI, Timers, UART, WDG and RTC).

The BlueNRG-248 very low power Bluetooth low energy (BLE) single-mode system on chip has 256 KB of Flash, 24 KB of RAM, a 32-bit core ARM cortex-M0 processor and several peripherals (ADC, 26 GPIOs, I²C, SPI, Timers, UART, WDG and RTC).

The microcontroller is connected to various components such as buttons, LEDs and sensors. The following table describes the microcontroller pin functions.

Table 2. BlueNRG-1, BlueNRG-2 pins description with board functions

Pin name	Pin no.		Board function									
	QFN3 2 ⁽¹⁾	QFN4 8 ⁽²⁾	LEDs	Micro	Buttons	Pressure sensor	3D accelerometer and gyroscope	JTAG	CN1	CN2	CN3	CN4
DIO10	1	46						JTMS-SWTDIO				
DIO9	2	47						JTCK-SWTCK				
DIO8	3	4		TXD (PA2)					pin 1 (IO8)		pin 2 (TX)	
DIO7	4	5	DL2						pin 2 (IO9)			pin 6 (SCL)
DIO6	5	5	DL1								pin 7 (IO6)	pin 5 (SDA)
VBAT3	6	40										

Pin name	Pin no.		Board function									
	QFN3 2 ⁽¹⁾	QFN4 8 ⁽²⁾	LEDs	Micro	Buttons	Pressure sensor	3D accelerometer and gyroscope	JTAG	CN1	CN2	CN3	CN4
DIO5	7	9				SDA (PUSH2 button)			pin 9 (SDA)			
DIO4	8	13				SCL			pin 10 (SCL)			
DIO3	9	14					SDO/SA0		pin 5 (MISO)		pin 6 (IO5)	
DIO2	10	15					SDA		pin 4 (MOSI)		pin 5 (IO4)	
DIO1	11	16					CS	JTAG- TDO	pin 3 (CS)			
DIO0	12	18					SCL	JTAG- TDI	pin 6 (SCK)		pin 4 (IO3)	
DIO14/ ANATES T0	13	21/23	DL3									pin 4 (AD3)
ANATES T1	14	24										
ADC1	15	25										
ADC2	16	26										
FXTAL1	17	27										
FXTAL0	18	28										
VBAT2	19	29										
RF1	20	30										
RF0	21	31										
SXTAL1	22	33										
SXTAL0	23	34										
VBAT1	24	35										
RESET	25	36		RESET	RESET			RESET		pin 3 (NRST)	pin 8 (IO7)	
SMPSFI LT1	26	37										
SMPSFI LT2	27	38										
VDD1V2	28	39										
DIO13	29	41			PUSH1							pin 3 (AD2)
DIO12	30	42					INT1					pin 1 (AD0)
FTEST	31	43										
DIO11	32	44		RXD (PA3)							pin 1 (RX) pin 3 (IO2)	pin 2 (AD1)

Pin name	Pin no.		Board function									
	QFN32 ⁽¹⁾	QFN48 ⁽²⁾	LEDs	Micro	Buttons	Pressure sensor	3D accelerometer and gyroscope	JTAG	CN1	CN2	CN3	CN4
DIO15	-	20										
DIO16	-	19										
DIO17	-	17										
DIO18	-	12										
DIO19	-	11										
DIO20	-	10										
DIO21	-	6										
DIO22	-	3										
DIO23	-	2										
DIO24	-	1										
VBAT4	-	8/22										
DIO25	-	48										

1. QFN32 package on STEVAL-IDB007Vx and STEVAL-IDB008Vx kits.
2. QFN48 package on STEVAL-IDB009Vx kits.

The board section labeled respectively BlueNRG-1, BlueNRG-2 (Figure 7. STEVAL-IDB007Vx board components, Figure 8. STEVAL-IDB008Vx board components, Figure 9. STEVAL-IDB009V1 board components – region B) includes the following main components:

- BlueNRG-1/BlueNRG-2 low power system on chip (in a QFN32 package for STEVAL-IDB007Vx, STEVAL-IDB008Vx, QFN48 package for STEVAL-IDB009Vx)
- BlueNRG-M2SA certified module based on the BlueNRG-2 Bluetooth LE SoC on STEVAL-IDB008V1M
- High frequency 16 MHz crystal on STEVAL-IDB007Vx and 32 MHz crystal on STEVAL-IDB008Vx, STEVAL-IDB009Vx
- Low frequency 32 kHz crystal for the lowest power consumption
- Integrated balun which integrates a matching network and harmonics filter
- SMA connector (not available on STEVAL-IDB007V1M/8V1M)

3.3 Power supply

Green LED DL4 (Figure 7. STEVAL-IDB007Vx board components, Figure 8. STEVAL-IDB008Vx board components, Figure 9. STEVAL-IDB009V1 board components – region G) signals the board is being powered, either via:

- micro USB connector CN5 (Figure 7. STEVAL-IDB007Vx board components, Figure 8. STEVAL-IDB008Vx board components, Figure 9. STEVAL-IDB009V1 board components – region C)
- two AAA batteries (region F)
- an external DC power supply plus micro USB connector

The following table describes the power supply modes available on the STEVAL-IDB007V1, STEVAL-IDB008V1 boards and corresponding jumper settings.

Table 3. STEVAL-IDB007Vx, STEVAL-IDB008Vx, STEVAL-IDB009Vx kit platform power supply modes

Power supply mode	JP1	JP2	Comment
1 - USB	Fitted: 1-2	Fitted: 2-3	USB supply through connector CN5 (Figure 7. STEVAL-IDB007Vx board components, Figure 8. STEVAL-IDB008Vx board components, Figure 9. STEVAL-IDB009V1 board components – region C)

Power supply mode	JP1	JP2	Comment
2 - Battery	Fitted: 2-3	Fitted: 1-2	The supply voltage must be provided through battery pins (region F).
3 - Combo	Fitted: 1-2	Optional	USB supply through connector CN5 for STM32L1; JP2 pin 2 external power for BlueNRG-1, BlueNRG-2

3.4 Jumpers

The available jumpers are listed in the table below.

Table 4. STEVAL-IDB007Vx, STEVAL-IDB008Vx, STEVAL-IDB009Vx kit platform jumpers

Jumper	Description
JP1	1-2: to provide power from USB (JP2: 2-3) 2-3: to provide power from battery holder (JP2: 1-2)
JP2	1-2: to provide power from battery holder (JP1: 2-3) 2-3: to provide power from USB (JP1: 1-2) JP2 pin 2 to VDD to provide external power supply to BlueNRG-1, BlueNRG-2 (JP1: 1-2)
JP3	pin 1 and 2 UART RX and TX of MCU pin 3 GND
JP4	Fitted: to provide VBLUE to BlueNRG-1, BlueNRG-2. It can be used also for current measurement.
JP5	Fitted: TEST pin to VBLUE Not fitted: TEST pin to GND

3.5 Sensors

The following sensors are available on the platform:

1. An LPS25HB (Figure 7. STEVAL-IDB007Vx board components, Figure 8. STEVAL-IDB008Vx board components, Figure 9. STEVAL-IDB009V1 board components – region H) is a piezoresistive absolute pressure sensor which functions as a digital output barometer. The device comprises a sensing element and an IC interface which communicates through I²C from the sensing element to the application.
2. An LSM6DS3 3D (region I) digital accelerometer and 3D digital gyroscope with embedded temperature sensor which communicates via SPI interface. One line for interrupt is also connected.

Note: In battery operating mode, if R59, R60 and R62 resistors are mounted, you should remove them to make LSM6DS3 function correctly.

3.6 Extension connector

BlueNRG-1, BlueNRG-2 signal test points are shared on two Arduino-compliant connector rows: CN1, CN3 (Figure 7. STEVAL-IDB007Vx board components, Figure 8. STEVAL-IDB008Vx board components, Figure 9. STEVAL-IDB009V1 board components – region J) and CN2, CN4 (region L). See Table 2. BlueNRG-1, BlueNRG-2 pins description with board functions.

3.7 Push-buttons

The board has one user button to reset the microcontroller (Figure 7. STEVAL-IDB007Vx board components, Figure 8. STEVAL-IDB008Vx board components, Figure 9. STEVAL-IDB009V1 board components – region M) and two further buttons for application purposes (region N).

Note: The PUSH1 button is not connected on the STEVAL-IDB008V1M as DIO13 is not available on the BlueNRG-M2SA module (PUSH1 is also not connected on STEVAL-IDB007V1M).

3.8 JTAG connector

A JTAG connector (Figure 7. STEVAL-IDB007Vx board components, Figure 8. STEVAL-IDB008Vx board components, Figure 9. STEVAL-IDB009V1 board components – region O) allows BlueNRG-1, BlueNRG-2 microcontroller programming and debugging with an in-circuit debugger and programmer such as ST-LINK/V2.

Note: Only SWD mode is supported

3.9 LEDs

LEDs DL1 (yellow), DL2 (red), DL3 (blue) and DL4 (green, power LED) are available on the board (Figure 7. STEVAL-IDB007Vx board components, Figure 8. STEVAL-IDB008Vx board components, Figure 9. STEVAL-IDB009V1 board components – regions G and P).

3.10 STM32L151CUB6 microcontroller

The most important feature of the STM32L151CUB6 48-pin microcontroller (Figure 7. STEVAL-IDB007Vx board components, Figure 8. STEVAL-IDB008Vx board components, Figure 9. STEVAL-IDB009V1 board components – regions Q) is the USB to serial bridge providing an I/O channel with the BlueNRG-1, BlueNRG-2 device.

The microcontroller is connected to the BlueNRG-1, BlueNRG-2 device through an ST2378E level translator (region R).

Note: The STM32L microcontroller on the board is not intended to be programmed by users. ST provides a pre-programmed firmware image for the sole purpose of interfacing BlueNRG-1, BlueNRG-2 to a USB host device (e.g., a PC).

3.11 Integrated balun with matching network and harmonics filter

BALF-NRG-01D3 and BALF-NRG-02D3 devices are ultra-miniature baluns which integrate matching network and harmonics filter on STEVAL-IDB007Vx and STEVAL-IDB008Vx. Discrete matching network is available on STEVAL-IDB009V1.

3.12 Current measurements

To monitor the power consumption of the BlueNRG-1, BlueNRG-2 only, remove the jumper from JP4 and insert an ammeter between pins 1 and 2 of the connector (when the power is ON, remove the USB connection).

Since power consumption of the BlueNRG-1, BlueNRG-2 are usually very low, an accurate instrument in the range of few micro amps is recommended.

3.13 Hardware setup

1. Connect an antenna to the SMA connector
2. Configure the board to USB power supply mode as per Table 3. STEVAL-IDB007Vx, STEVAL-IDB008Vx, STEVAL-IDB009Vx kit platform power supply modes
3. Connect the board to a PC via USB cable (connector CN5)
4. Verify the power indication LED DL4 is on.

4 BlueNRG-1, BlueNRG-2 Navigator

BlueNRG-1, BlueNRG-2 Navigator are user friendly GUI which lets you select and run demonstration applications easily, without requiring any extra hardware. With it, you can access the following DK software package components:

- BlueNRG-1, BlueNRG-2 Bluetooth low energy (BLE) demonstration applications
- BlueNRG-1, BlueNRG-2 peripheral driver examples
- BlueNRG-1, BlueNRG-2 2.4 GHz radio proprietary examples
- BlueNRG-1, BlueNRG-2 development kits
- release notes
- license files

With BlueNRG-1, BlueNRG-2 DK Navigator, you can directly download and run the selected prebuilt application binary image (BLE examples or peripheral driver example) on the BlueNRG-1, BlueNRG-2 platform without a JTAG interface.

The interface gives demo descriptions and access to board configurations and source code if needed.

User can run the utility through the BlueNRG-1 and BlueNRG-2 Navigator icon under:
Start → ST BlueNRG -1_2 DK X.X.X → BlueNRG-1 Navigator, BlueNRG-2 Navigator.

Figure 10. BlueNRG-1 Navigator



Note: BlueNRG-1 Navigator and BlueNRG-2 Navigator are two instances of the same application tailored for the specific selected device, in order to select the related available resources. Next sections focus on BlueNRG-1 Navigator, but same concepts are also valid for BlueNRG-2 Navigator.

4.1 BlueNRG-1 Navigator 'Demonstration Applications'

You can navigate the menus for the reference/demo application you want to launch. For each application, the following information is provided:

- Application settings (if applicable)
- Application description
- Application hardware related information (e.g., LED signals, jumper configurations, etc.)

The following functions are also available for each application:

- **Flash:** to automatically download and run the available prebuilt binary file to a BlueNRG-1 platform connected to a PC USB port.
- **Doc:** to display application documentation (html format)
- **Project:** to open the project folder with application headers, source and project files.

The figure below shows you how to run the BLE Beacon demo application; the other demos function similarly.

Figure 11. BLE Beacon application



When a BlueNRG-1 platform is connected to your PC USB port, you can press the “Flash & Run” tab on the selected application window to download and run the available prebuilt application binary image on the BlueNRG-1 platform.

Figure 12. BLE Beacon Flash programming



Selecting the “Doc” tab opens the relative html documentation.

Figure 13. BLE Beacon documentation



4.1.1 BlueNRG-1 Navigator 'Basic examples'

This page lists some basic sample applications for the BlueNRG-1 device to verify that BlueNRG-1 device is alive as well as the device sleep and wakeup modes.

Figure 14. Basic examples



4.1.2 BlueNRG-1 Navigator 'BLE demonstration and test applications'

This page lists all the available Bluetooth low energy (BLE) demonstration applications in the DK software package. These applications provide usage examples of the BLE stack features for the BlueNRG-1 device.

Figure 15. BLE demonstration and test applications



4.1.3 BlueNRG-1 Navigator 'Peripherals driver examples'

This page lists the available BlueNRG-1 peripherals and corresponding test applications to work with certain features specific to the selected BlueNRG-1 peripheral.

Figure 16. Peripherals driver examples



4.1.4 BlueNRG-1 Navigator '2.4 GHz radio proprietary examples'

The Radio low level driver provides access to the BlueNRG-1 device radio to send and receive packets without using the Bluetooth link layer.

The 2.4 GHz radio proprietary examples built on top of the Radio low level driver can be used as reference examples for building other applications which use the BlueNRG-1 Radio.

Figure 17. 2.4 GHz radio proprietary examples



4.2 BlueNRG-1 Navigator 'Development Kits'

This window displays the available BlueNRG-1 DK kit platforms and corresponding resources. When you hover the mouse pointer on a specific item, the related component is highlighted on the board.

Figure 18. STEVAL-IDB007V2 kit components



4.2.1 BlueNRG-1 Navigator 'Release Notes' and 'License'

As their name suggests, these pages display the DK SW package Release Notes (html format) and the DK software package license file, respectively.

5 BlueNRG-X Radio Init Parameters Wizard

The BlueNRG-X Radio Parameters Wizard is a PC application which allows to define the proper values required for the correct BlueNRG-1, BlueNRG-2 BLE radio initialization, based on the specific user application scenario. As consequence of the user choices, a configuration header file (*_config.h) is generated: this file must be used on the user demonstration application folder.

Note: *The BlueNRG-X Radio Init Parameters Wizard is provided only on BlueNRG-1_2 DK SW package (STSW-BLUENRG1-DK) supporting BLE stack v2.x family.*

5.1 How to run

User can run this utility by clicking on the BlueNRG-X Radio Init Parameters Wizard icon under: Start → ST BlueNRG -1_2 DK X.X.X

Figure 19. BlueNRG-X Radio Init Parameters Wizard

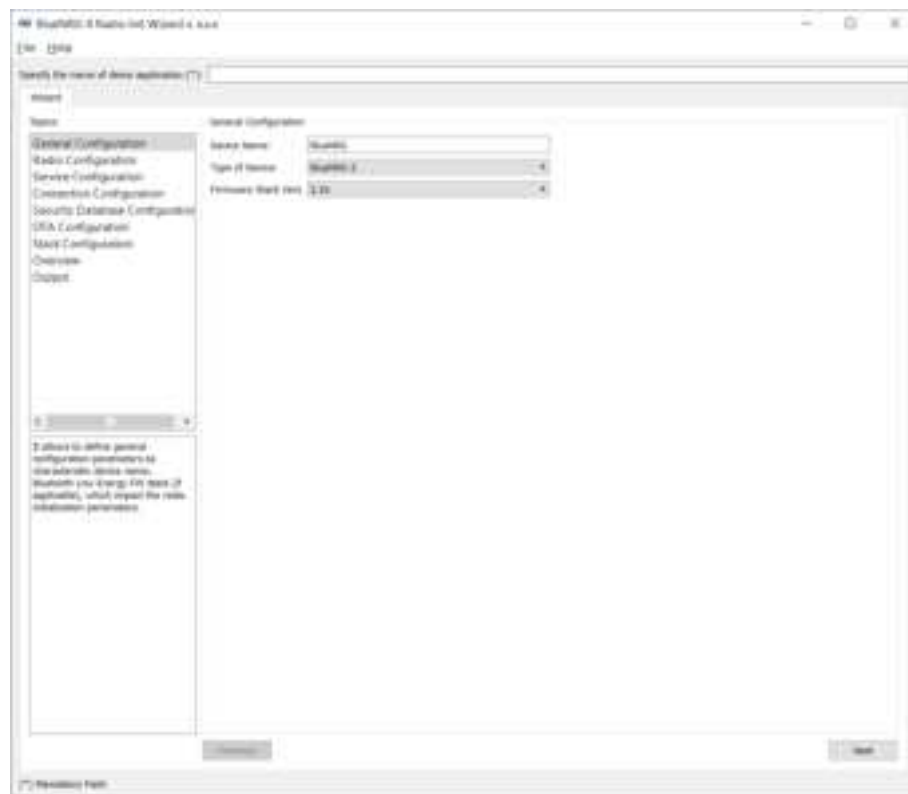

5.2 Main user interface window

In the left section of the BlueNRG-X Radio Init Parameters Wizard Utility, user can select the following topics allowing to define the specific radio initialization parameters based on the specific BLE application requirements:

1. General Configuration
2. Radio Configuration
3. Service Configuration
4. Connection Configuration
5. Security DataBase configuration
6. OTA configuration
7. Stack configuration
8. Overview

9. Output

Refer to the BlueNRG-X Radio Init Parameters Wizard documentation available within BlueNRG-1_2 DK SW package for more details about each provided configuration section.

6 Programming with BlueNRG-1, BlueNRG-2 system on chip

The BlueNRG-1, BlueNRG-2 Bluetooth low energy (BLE) stack is provided as a binary library. A set of APIs to control BLE functionality. Some callbacks are also provided for user applications to handle BLE stack events. The user is simply requested to link this binary library to his or her application and use the relevant APIs to access BLE functions and complete the stack event callbacks to manage responses according to application requirements.

A set of software driver APIs is also included for accessing the BlueNRG-1, BlueNRG-2 SoC peripherals and resources (ADC, GPIO, I²C, MFTX, Micro, RTC, SPI, SysTick, UART and WDG).

The development kit software includes sample code demonstrating how to configure BlueNRG-1, BlueNRG-2 and use the device peripherals and BLE APIs and event callbacks. Documentation on the BLE APIs, callbacks, and peripheral drivers are provided in separate documents.

6.1 Software directory structure

The BlueNRG-1, BlueNRG-2 DK software packages files are organized in the following main directories:

- **Application:** containing BlueNRG-1, BlueNRG-2 Navigator and Radio Init Parameters Wizard PC applications.
- **Doc:** with doxygen BLE APIs and events, BlueNRG-1, BlueNRG-2 peripheral drivers, BLE demo applications, BlueNRG-1, BlueNRG-2 Peripheral examples, BlueNRG-1, BlueNRG-2 SDK and HAL driver documentation, DK release notes and license file.
- **Firmware:** with prebuilt binary BLE and peripheral driver sample applications.
- **Library**
 - **Bluetooth LE:** Bluetooth low energy stack binary library and all the definitions of stack APIs, stack and events callbacks. BLE stack v2.1 or later configuration header and source files.
 - **cryptolib:** AES library.
 - **BLE_Application:** BLE application framework files (BLE stack layers define values, OTA FW upgrade, BLE utilities, master library).
 - **BlueNRG1_Periph_Driver:** BlueNRG-1, BlueNRG-2 drivers for device peripherals (ADC, clock, DMA, Flash, GPIO, I²C, timers, RTC, SPI, UARR and watchdog).
 - **CMSIS:** BlueNRG-1 CMSIS files.
 - **SDK_Eval_BlueNRG1:** SDK drivers providing an API interface to the BlueNRG-1, BlueNRG-2 platform hardware resources (LEDs, buttons, sensors, I/O channel).
 - **HAL:** Hardware abstraction level APIs for abstracting certain BlueNRG-1 hardware features (sleep modes, clock based on SysTick, etc.).
 - **STM32L:** BlueNRG-1, 2 network coprocessor framework example for an external microcontroller
- **Project**
 - **BLE_Examples:** Bluetooth low energy demonstration application including Headers, source files and EWARM, Keil and Atollic project files.
 - **BlueNRG1_Periph_Examples:** with sample applications for the BlueNRG-1, BlueNRG-2 peripherals and hardware resources, including Headers, source files and project files.
 - **STM32L:** BlueNRG-1, 2 network coprocessor demonstration application examples for an external microcontroller.
- **Utility:** contains some utilities

Note: The selection between BlueNRG-1, BlueNRG-2 device is done at compile time using a specific define value `BLUENRG2_DEVICE` for selecting BlueNRG-2 device. Default configuration (no define value) selects BlueNRG-1 device.

Note: `BLE_Application` folder is available only on BlueNRG-1_2 DK SW package v3.0.0 or later.

Note: Starting from BlueNRG-1_2 DK SW package 3.1.0, Library, Project and Utility folders are located under `C:\Users\{username}\ST\BlueNRG-1_2 DK x.x.x`, in order to be able to directly compile projects even with Windows User Account Control activated.

7 BLE beacon demonstration application

The BLE beacon demo is supported by the [BlueNRG-1](#), [BlueNRG-2](#) development platforms (STEVAL-IDB007Vx, STEVAL-IDB008Vx, STEVAL-IDB009Vx). It demonstrates how to configure a BlueNRG-1 device to advertise specific manufacturing data and allow another BLE device to determine whether it is in BLE beacon device range.

7.1 BLE Beacon application setup

This section describes how to configure a BLE device to act as a beacon device.

7.1.1 Initialization

The BLE stack must be correctly initialized thus:

```
aci_gatt_init();
aci_gap_init(GAP_PERIPHERAL_ROLE, 0, 0x08, &service_handle, &dev_name_char_handle, &appearance_char_handle);
```

See the BLE stack documentation for more information on these and following commands.

7.1.2 Define advertising data

The BLE Beacon application advertises the following manufacturing data:

Table 5. BlueNRG-1 Beacon advertising manufacturing data

Data field	Description	Notes
Company identifier code	SIG company identifier ⁽¹⁾	Default is 0x0030 (STMicroelectronics)
ID	Beacon ID	Fixed value
Location UUID	Beacons UUID	Used to distinguish specific beacons from others
Major number	Identifier for a group of beacons	Used to group a related set of beacons
Minor number	Identifier for a single beacon	Used to identify a single beacon
Tx Power	2's complement of the Tx power	Used to establish how far you are from device

1. available at: <https://www.bluetooth.org/en-us/specification/assigned-numbers/company-identifiers>

7.1.3 Entering non-connectable mode

The BLE Beacon device uses the GAP API command to enter non-connectable mode thus:

```
aci_gap_set_discoverable(ADV_NONCONN_IND, 160, 160, PUBLIC_ADDR,
                        NO_WHITE_LIST_USE, 0, NULL, 0, NULL, 0, 0);
```

To advertise the specific selected manufacturer data, the BLE Beacon application can use the following GAP APIs:

```
/* Remove TX power level field from the advertising data: it is necessary to have
enough space for the beacon manufacturing data */
aci_gap_delete_ad_type(AD_TYPE_TX_POWER_LEVEL);
/* Define the beacon manufacturing payload */
uint8_t manu_data[] = {26, AD_TYPE_MANUFACTURER_SPECIFIC_DATA, 0x30, 0x00,
//Company identifier code (Default is 0x0030 - STMicroelectronics) 0x02, // ID
0x15, //Length of the remaining payload
0xE2, 0x0A, 0x39, 0xF4, 0x73, 0xF5, 0x4B, 0xC4, //Location UUID
0xA1, 0x2F, 0x17, 0xD1, 0xAD, 0x07, 0xA9, 0x61,
0x00, 0x02, // Major number
0x00, 0x02, // Minor number
0xC8 //2's complement of the Tx power (-56dB)};
};
/* Set the beacon manufacturing data on the advertising packet */ aci_gap_update_adv_data(27,
manu_data);
```

Note: *BLE Beacon with Flash Management demonstration application is also available. It allows to configure a Beacon device as with the original Beacon demo application; it also shows how to properly handle Flash operations (Erase and Write) and preserve the BLE radio activities. This is achieved by synchronizing Flash operations with the scheduled BLE radio activities through the `aci_hal_end_of_radio_activity_event()` event callback timing information.*

7.2 BLE Beacon FreeRTOS example

A specific new Beacon project (*BLE_Beacon_FreeRTOS*) shows how to use FreeRTOS with ST BLE stack v2.x. The example configures a BLE device in advertising mode (non-connectable mode) with specific manufacturing data and the *BTLE_StackTick()* is called from a FreeRTOS task (*BLETask*).

A task randomly changes the Minor number in the advertising data every 500 ms, sending a message through UART each time. Another task sends other messages through UART every 200 ms and generates a short pulse on LED3 (visible with a logic analyzer or oscilloscope).

In this example, low priority has been assigned to the *BLETask*.

Assigning high priority to a *BLETask* can give better latency; if some tasks require a lot of CPU time, it is recommended to assign them a lower priority than the *BLETask* to avoid BLE operations slowing down. Only for tasks that perform very short sporadic operations before waiting for an event, it is still reasonable to choose a priority higher than the *BLETask*.

8 BLE chat demo application

The BLE chat demo (server and client roles) is supported on the [BlueNRG-1](#), [BlueNRG-2](#) development platforms (STEVAL-IDB007Vx, STEVAL-IDB008Vx, STEVAL-IDB009Vx). It implements simple two-way communication between two BLE devices, demonstrating point-to-point wireless communication using the BlueNRG-1 product.

This demo application exposes a single chat service with the following (20 byte max.) characteristic values:

- The TX characteristic, with which the client can enable notifications; when the server has data to be sent, it sends notifications with the value of the TX characteristic.
- The RX characteristic, is a writable characteristic; when the client has data to be sent to the server, it writes a value in this characteristic.

There are two device roles which can be selected through the specific project workspace:

- The Server that exposes the chat service (BLE peripheral device).
- The Client that uses the chat service (BLE central device).

The application requires two devices to be programmed with respective server and client roles. These must be connected to a PC via USB with an open serial terminal for each device, with the following configurations:

Table 6. Serial port configuration

Parameter	Value
Baudrate	115200 bit/s
Data bits	8
Parity bits	None
Stop bits	1

The application listens for keys typed in one device terminal and sends them to the remote device when the return key is pressed; the remote device then outputs the received RF messages to the serial port. Therefore, anything typed in one terminal becomes visible in the other.

8.1 Peripheral and central device setup

This section describes how two BLE chat devices (server-peripheral and client-central) interact with each other to set up a point-to-point wireless chat.

BLE device must first be set up on both devices by sending a series of API commands to the processor.

8.1.1 Initialization

The BLE stack must be correctly initialized before establishing a connection with another BLE device. This is done with `aci_gatt_init()` and `aci_gap_init()` APIs:

```
aci_gatt_init();
```

BLE Chat server role:

```
aci_gap_init(GAP_PERIPHERAL_ROLE, 0, 0x08, &service_handle, &dev_name_char_handle, &appearance_char_handle);
```

BLE Chat client role:

```
aci_gap_init(GAP_CENTRAL_ROLE, 0, 0x08, &service_handle, &dev_name_char_handle, &appearance_char_handle);
```

Peripheral and central BLE roles must be specified in the `aci_gap_init()` command. See the BLE stack API documentation for more information on these and following commands.

8.1.2 Add service and characteristics

The chat service is added to the BLE chat server device via:

```
aci_gatt_add_service(UUID_TYPE_128, &service_uuid, PRIMARY_SERVICE, 7, &chatServHandle);
```

Where `service_uuid` is the private service 128-bit UUID allocated for the chat service (Primary service). The command returns the service handle in `chatServHandle`. The TX characteristic is added using the following command on the BLE Chat server device:

```
aci_gatt_add_char(chatServHandle, UUID_TYPE_128, &charUuidTX, 20, CHAR_PROP_NOTIFY, ATTR_PERMISSION_NONE, 0, 16, 1, &TXCharHandle);
```

Where `charUuidTX` is the private characteristic 128-bit UUID allocated for the TX characteristic (notify property). The characteristic handle is returned on the `TXCharHandle` variable.

The RX characteristic is added using the following command on the BLE Chat server device:

```
aci_gatt_add_char(chatServHandle, UUID_TYPE_128, &charUuidRX, 20, CHAR_PROP_WRITE|CHAR_PROP_WRITE_WITHOUT_RESP, ATTR_PERMISSION_NONE, GATT_SERVER_ATTR_WRITE, 16, 1, &RXCharHandle);
```

Where `charUuidRX` is the private characteristic 128-bit UUID allocated for the RX characteristic (write property). The characteristic handle is returned on the `RXCharHandle` variable.

See the BLE stack API documentation for more information on these and following commands.

8.1.3 Enter connectable mode

The server device uses GAP API commands to enter the general discoverable mode:

```
aci_gap_set_discoverable(ADV_IND, 0, 0, PUBLIC_ADDR, NO_WHITE_LIST_USE, 8, local_name, 0, NULL, 0, 0);
```

The `local_name` parameter contains the name presented in advertising data, as per Bluetooth core specification version 4.2, Vol. 3, Part C, Ch. 11.

8.1.4 Connection with central device

Once the server device is discoverable by the BLE chat client device, the client device uses `aci_gap_create_connection()` to connect with the BLE chat server device:

```
aci_gap_create_connection(0x4000, 0x4000, PUBLIC_ADDR, bdaddr, PUBLIC_ADDR, 40, 40, 0, 60, 2000, 2000);
```

Where `bdaddr` is the peer address of the client device.

Once the two devices are connected, you can set up corresponding serial terminals and type messages in either of them. The typed characters are stored in two respective buffers and when the return key is pressed:

- on the BLE chat server device, the typed characters are sent to the BLE chat client device by notifying the previously added TX characteristic (after notifications are enabled) with:

```
aci_gatt_update_char_value(chatServHandle, TXCharHandle, 0, len, (uint8_t*)cmd+j);
```

- on the BLE chat client device, the typed characters are sent to the BLE chat server device by writing the previously added RX characteristic with:

```
aci_gatt_write_without_resp(connection_handle, rx_handle+1, len, (uint8_t *)cmd+j);
```

Where `connection_handle` is the handle returned upon connection as a parameter of the connection complete event, `rx_handle` is the RX characteristic handle discovered by the client device.

Once these API commands have been sent, the values of the TX and RX characteristics are displayed on the serial terminals.

Figure 20. BLE chat client

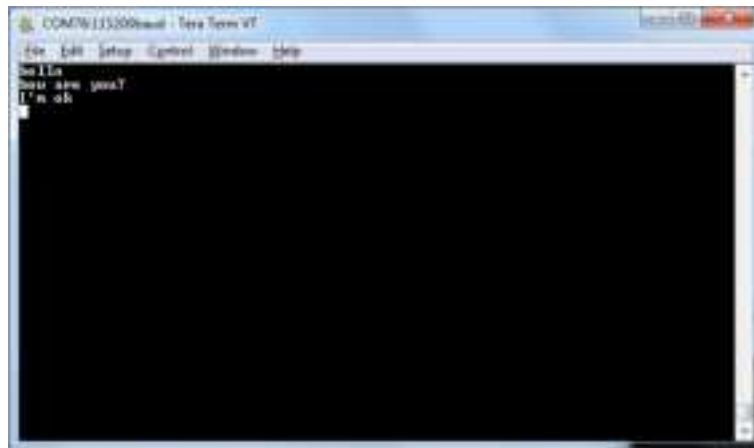
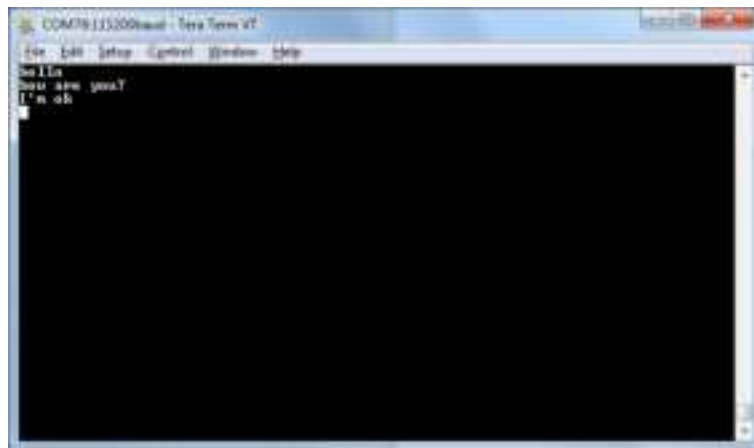

Figure 21. BLE chat server



9 BLE chat master and slave demo application

The BLE chat master and slave demo is supported on the [BlueNRG-1](#), [BlueNRG-2](#) development platforms (STEVAL-IDB007Vx, STEVAL-IDB008Vx, STEVAL-IDB009Vx). It demonstrates simple point-to-point wireless communication using a single application which configures the chat client and server roles at runtime.

The new chat demo application configures a BLE device as central or peripheral using the API:

```
aci_gap_init(GAP_CENTRAL_ROLE|GAP_PERIPHERAL_ROLE, 0, 0x07, &service_handle, &dev_name_char_h  
andle, &appearance_char_handle);
```

It then initiates a discovery procedure for another BLE device configured with the same chat master and slave application image.

If such a device is found within a random interval, it starts a connection procedure and waits until a connection is established. If the discovery procedure time expires without finding another chat master and slave device, the device enters discovery mode and waits for another chat master and slave device to discover and connect to it.

When connection is established, the client and server roles are defined and the chat communication channel can be used.

This demo application exposes a single chat service with the following (20 byte max.) characteristic values:

- The TX characteristic, with which the client can enable notifications; when the server has data to be sent, it sends notifications with the value of the TX characteristic.
- The RX characteristic, is a writable characteristic; when the client has data to be sent to the server, it writes a value in this characteristic.

The application requires two devices to be programmed with the same application, with the server and client roles defined at runtime. Connect the two devices to a PC via USB and open a serial terminal on both with the same configuration as [Table 6. Serial port configuration](#).

The application listens for keys typed in one device terminal and sends them to the remote device when the return key is pressed; the remote device then outputs the received RF messages to the serial port. Therefore, anything typed in one terminal becomes visible in the other.

9.1 BLE chat master and slave roles

This section describes how two BLE chat master and slave devices interact with each other in order to set up a point-to-point wireless chat.

The BLE stack must first be set up on both devices by sending a series of API commands to the processor. The chat master and slave client and server roles are defined at runtime.

9.1.1 Initialization

The BLE stack must be correctly initialized before establishing a connection with another BLE device. This is done with two commands:

```
aci_gatt_init();
```

```
aci_gap_init(GAP_CENTRAL_ROLE|GAP_PERIPHERAL_ROLE, TRUE,0x07, &service_handle, &dev_name_char  
_handle, &appearance_char_handle);
```

The BLE peripheral and central roles are specified in the `aci_gap_init()` command. See the BLE API documentation for more information on these and following commands.

9.1.2 Add service and characteristics

Refer to [Section 8.1.2 Add service and characteristics](#).

9.1.3 Start discovery procedure

To find another BLE chat master and slave device in discovery mode, a discovery procedure must be started via:

```
aci_gap_start_general_discovery_proc(0x4000, 0x4000, 0x00, 0x00);
```

9.1.4 Enter connectable mode

The following GAP API command is used for entering general discoverable mode:

```
aci_gap_set_discoverable(ADV_IND, 0x90, 0x90, PUBLIC_ADDR, NO_WHITE_LIST_USE, sizeof(local_name), local_name, 0, NULL, 0x6, 0x8);
```

9.1.5 Connection with chat master and slave client device

In the above mentioned discovery and mode assignment procedures, the two chat master and slave applications assume respective client and server roles at runtime. During this initial configuration phase, when a chat master and slave device is placed in discoverable mode and it is found by the other chat master and slave device performing a discovery procedure, a Bluetooth low energy connection is created and the device roles are defined. The following GAP API command is used for connecting to the discovered device:

```
aci_gap_create_connection(0x4000, 0x4000, device_found_address_type, device_found_address, PUBLIC_ADDR, 40, 40, 0, 60, 2000, 2000);
```

Where `device_found_address_type` is the address type of the discovered chat master and slave and `device_found_address` is the peer address of the discovered chat master and slave device.

Once the two devices are connected, you can set up corresponding serial terminals and type messages in either of them. The typed characters are stored in two respective buffers and when the return key is pressed:

On the BLE chat master-and-slave server device, the typed characters are sent to the master-and-slave client device by notifying the previously added TX characteristic (after notifications have been enabled). This is done via:

```
aci_gatt_update_char_value(chatServHandle, TXCharHandle, 0, len, (uint8_t *)cmd+j);
```

On the master-and-slave client device, the typed characters are sent to the master-and-slave server device, by writing the previously added RX characteristic. This is done via:

```
aci_gatt_write_without_resp (connection_handle, rx_handle +1, len, (uint8_t *)cmd+j);
```

Where `connection_handle` is the handle returned upon connection as a parameter of the connection complete event, `rx_handle` is the RX characteristic handle discovered by the client device.

Once these API commands have been sent, the values of the TX and RX characteristics are displayed on the serial terminals.

10 BLE remote control demo application

The BLE remote control application is supported on the [BlueNRG-1](#), [BlueNRG-2](#) development platforms (STEVAL-IDB007Vx, STEVAL-IDB008Vx, STEVAL-IDB009Vx). It demonstrates how to control a remote device (like an actuator) using a BlueNRG-1, BlueNRG-2 device.

This application periodically broadcasts temperature values that can be read by any device. The data is encapsulated in a manufacturer-specific AD type and the content (besides the manufacturer ID, i.e., 0x0030 for STMicroelectronics) is as follows:

Table 7. BLE remote advertising data

Byte 0	Byte 1	Byte2
App ID (0x05)	Temperature value (little-endian)	

The temperature value is given in tenths of degrees Celsius.

The device is also connectable and exposes a characteristic used to control LEDs DL1 and DL3 on the BLE kit platform. The value of this characteristic is a bitmap of 1 byte. Each bit controls one of the LEDs:

- bit 0 is the status of LED DL1
- bit 2 is the status of LED DL3.

A remote device can therefore connect and write this byte to change or read the status of these LEDs (1 for LED ON, 0 for LED OFF).

The peripheral disconnects after a timeout (`DISCONNECT_TIMEOUT`) to prevent a central device remaining connected to the device indefinitely.

Security is not enabled by default, but this can be changed with `ENABLE_SECURITY` (refer to file `BLE_RC_main.h`). When security is enabled, the central device must be authenticated before reading or writing the device characteristic.

To interact with a device configured as a BLE remote control, another BLE device (a BlueNRG-1, BlueNRG-2 or any Bluetooth® Low Energy device) can be used to detect and view broadcast data.

To control one of the LEDs, the device has to connect to a BlueNRG-1 BLE remote control device and write in the exposed control point characteristic. The Service UUID is `ed0ef62e-9b0d-11e4-89d3-123b93f75cba`. The control point characteristic UUID is `ed0efb1a-9b0d-11e4-89d3-123b93f75cba`.

10.1 BLE remote control application setup

This section describes how to configure a [BlueNRG-1](#) device to acting as a remote control device.

10.1.1 Initialization

The BLE stack must be correctly initialized before establishing a connection with another Bluetooth LE device. This is done with two commands:

```
aci_gatt_init();
aci_gap_init(GAP_PERIPHERAL_ROLE, 0, 0x07, &service_handle, &dev_name_char_handle, &appearance_char_handle);
```

See BLE stack API documentation for more information on these and following commands.

10.1.2 Define advertising data

The BLE remote control application advertises certain manufacturing data as follows:

```

/* Set advertising device name as Node */
const uint8_t scan_resp_data[] = {0x05,AD_TYPE_COMPLETE_LOCAL_NAME,'N','o','d','e'}
/* Set scan response data */ hci_le_set_scan_response_data(sizeof(scan_resp_data),scan_resp_data);
/* Set Undirected Connectable Mode */
aci_gap_set_discoverable(ADV_IND, (ADV_INTERVAL_MIN_MS*1000)/625,
(ADV_INTERVAL_MAX_MS*1000)/625, PUBLIC_ADDR, NO_WHITE_LIST_USE, 0, NULL, 0, NULL, 0, 0);
/* Set advertising data */
hci_le_set_advertising_data(sizeof(adv_data),adv_data);

```

On the development platform, the temperature sensor value is set in the `adv_data` variable.

10.1.3

Add service and characteristics

The BLE Remote Control service is added via:

```
aci_gatt_add_service(UUID_TYPE_128, &service_uuid, PRIMARY_SERVICE, 7,
&RCServHandle);
```

Where `service_uuid` is the private service 128-bit UUID allocated for the BLE remote service (ed0ef62e-9b0d-11e4-89d3-123b93f75cba).

The command returns the service handle in `RCServHandle`.

The BLE remote control characteristic is added using the following command:

```

#if ENABLE_SECURITY
aci_gatt_add_char(RCServHandle, UUID_TYPE_128, &controlPointUuid, 1,
CHAR_PROP_READ|CHAR_PROP_WRITE|CHAR_PROP_WRITE_WITHOUT_RESP|CHAR_PROP_SIGNED_WRITE,
ATTR_PERMISSION_AUTHEN_READ|ATTR_PERMISSION_AUTHEN_WRITE, GATT_NOTIFY_ATTRIBUTE_WRITE,16,1,&controlPointHandle);
#else
aci_gatt_add_char(RCServHandle, UUID_TYPE_128, &controlPointUuid, 1,
CHAR_PROP_READ|CHAR_PROP_WRITE|CHAR_PROP_WRITE_WITHOUT_RESP, ATTR_PERMISSION_NONE, GATT_NOTIFY_ATTRIBUTE_WRITE, 16,
1,&controlPointHandle);
#endif

```

Where `controlPointUuid` is the private characteristic 128-bit UUID allocated for BLE remote control characteristic (ed0efb1a-9b0d-11e4-89d3-123b93f75cba) and `controlPointHandle` is the BLE remote control characteristic handle.

If security is enabled, the characteristic properties must be set accordingly to enable authentication on `controlPointUuid` characteristic read and write.

10.1.4

Connection with a BLE Central device

When connected to a BLE central device (another [BlueNRG-1](#), [BlueNRG-2](#) device or any Bluetooth® Low Energy device), the `controlPointUuid` characteristic is used to control the BLE remote control platform LED. Each time a write operation is performed on `controlPointUuid`, the `aci_gatt_attribute_modified_event()` callback is raised and the selected LEDs are turned on or off.

11 BLE sensor profile demo

The BLE sensor profile demo is supported on the [BlueNRG-1](#), [BlueNRG-2](#) development platforms (STEVAl-
IDB007Vx, STEVAL-IDB008Vx, STEVAL-IDB009Vx). It implements a proprietary, Bluetooth low energy (BLE)
sensor profile.

This example is useful for building new profiles and applications that use the BlueNRG-1, BlueNRG-2 SoC. The
GATT profile is not compliant with any existing specifications as the purpose of this project is to simply
demonstrate how to implement a given profile.

This profile exposes the acceleration and environmental services.

[Figure 22. BLE sensor demo GATT database](#) shows the whole GATT database, including the GATT (0x1801) and
GAP (0x1800) services that are automatically added by the stack.

The acceleration service free fall characteristic cannot be read or written, but can be signaled. The application
sends notification of this characteristic (with a value of 0x01) if a free fall condition is detected by the MEMS
sensor (when the acceleration on the three axes is near zero for a certain amount of time). Notifications can be
enabled or disabled by writing the associated client characteristic configuration descriptor.

The other characteristic exposed by the service gives the current value of the acceleration measured by the
accelerometer in six bytes. Each byte pair contains the acceleration on one of the three axes. The values are
given in mg. This characteristic is readable and can be notified if notifications are enabled.

Another service is defined, which contains characteristics that expose data from some environmental sensors:
temperature and pressure. Each characteristic data type is described in a format descriptor. All of the
characteristics have read-only properties.

Figure 22. BLE sensor demo GATT database

# Handle	UUID (16 or 128bit)	Attribute Type	Properties	Initial Parameter Value	Comment
1	0001	2000	Primary Service	[Service=0x1801 ("Attribute Profile")]	
2	0002	2003	Characteristic	X	[Handle=0x0003, UUID=0x2A05]
3	0003	2A05	Service Changed		[Start handle=0x0003, end handle=0xFFFF]
4	0004	2902	Client Characteristic Configuration		0x0000
5	0005	2000	Primary Service	[Service=0x1800 ("Generic Access Profile")]	
6	0006	2003	Characteristic	X X X X	[Handle=0x0007, UUID=0x2A00]
7	0007	2A00	Device Name		"Muegg"
8	0008	2003	Characteristic	X X X	[Handle=0x0009, UUID=0x2A01]
9	0009	2A01	Appearance		0x0000
12	000C	2000	Primary Service	[Service=0x1802 (0CF4) ("Acc. Sensor")]	
13	000D	2003	Characteristic	X	[Handle=0x000E, UUID=0x23E73A8CF4A11E18FFC8002A5D6C51E]
14	000E	E23E73A8CF4A11E18FFC8002A5D6C51E	Free Fall		Indication with value 1 when a free fall condition is detected
15	000F	2902	Client Characteristic Configuration		0x0000
16	0010	2003	Characteristic	X X	[Handle=0x0011, UUID=0x385A1880CF4B11E1AC36002A5D6C51E]
17	0011	385A1880CF4B11E1AC36002A5D6C51E	Acceleration		3-Axis (2bytes) Y-Axis (2bytes) Z-Axis (2bytes)
18	0012	2902	Client Characteristic Configuration		0x0000
19	0013	2000	Primary Service	[Service=0x1803 (A4E4) ("Env. Sensor")]	
20	0014	2003	Characteristic	X	[Handle=0x0015, UUID=0xA3E5520E4771E23A9E3002A5D6C51E]
21	0015	A3E5520E4771E23A9E3002A5D6C51E	Temperature		Temperature in tenths of degree Celsius
22	0016	2904	Characteristic Format		[Format=0x0E, exp=1, unit=0x272F, n_sps=0x00, desc=0x0000]
23	0017	2003	Characteristic	X	[Handle=0x0018, UUID=0xC20C48048D11E2843E002A5D6C51E]
24	0018	C20C48048D11E2843E002A5D6C51E	Pressure		Pressure in hundredths of millibar
25	0019	2904	Characteristic Format		[Format=0x0F, exp=4, unit=0x279E, n_sps=0x00, desc=0x0000]
26	001A	2003	Characteristic	X	[Handle=0x001B, UUID=0x07C3060E48C11E23A9E3002A5D6C51E]

11.1 BlueNRG app for smartphones

An application is available for iOS™ and Android™ smartphones or tablets that also works with the BLE sensor
profile demo. This app enables notification of the acceleration characteristic and displays the value on screen.
Data from environmental sensors are also periodically read and displayed.

Figure 23. BlueNRG sensor app



11.2 BLE sensor profile demo: connection with a central device

This section describes how to interact with a central device, while the BLE stack is acting as a peripheral. The central device may be another [BlueNRG-1](#), [BlueNRG-2](#) device acting as a BLE master, or any other Bluetooth Low Energy device.

The BLE stack must first be set up by sending a series of BLE API commands to the processor.

11.2.1 Initialization

The BLE stack must be correctly initialized before establishing a connection with another Bluetooth LE device. This is done via:

```
aci_gatt_init();
aci_gap_init(GAP_PERIPHERAL_ROLE, 0, 0x07, &service_handle, &dev_name_char_handle, &appearance_char_handle);
```

See BLE stack API documentation for more information on these and following commands.

11.2.2 Add service and characteristics

The BlueNRG-1 BLE stack has both server and client capabilities. A characteristic is an element in the server database where data is exposed, while a service contains one or more characteristics. The acceleration service is added with the following command:

```
aci_gatt_add_service(UUID_TYPE_128, &service_uuid, PRIMARY_SERVICE, 7, &accServHandle);
```

The command returns the service handle on variable `accServHandle`. The free fall and acceleration characteristics must now be added to this service thus:

```
aci_gatt_add_char(accServHandle, UUID_TYPE_128, &char_uuid, 1, CHAR_PROP_NOTIFY, ATTR_PERMISSION_NONE, 16, 0, &freeFallCharHandle);
aci_gatt_add_char(accServHandle, UUID_TYPE_128, &char_uuid, 6, CHAR_PROP_NOTIFY|CHAR_PROP_READ, ATTR_PERMISSION_NONE, GATT_NOTIFY_READ_REQ_AND_WAIT_FOR_APPL_RESP, 16, 0, &accCharHandle);
```

The free fall and acceleration characteristics handles are returned on `freeFallCharHandle` and `accCharHandle` variables respectively.

Similar steps are followed for adding the environmental sensor and relative characteristics.

11.2.3 Enter connectable mode

Use GAP API command to enter one of the discoverable and connectable modes:

```
aci_gap_set_discoverable(ADV_IND, (ADV_INTERVAL_MIN_MS*1000)/625,  
ADV_INTERVAL_MAX_MS*1000)/625, STATIC_RANDOM_ADDR, NO_WHITE_LIST_USE sizeof(local_name), local_name, 0, NULL, 0, 0);
```

Where

```
local_name[] = {AD_TYPE_COMPLETE_LOCAL_NAME, 'B', 'l', 'u', 'e', 'N', 'R', 'G'};
```

The `local_name` parameter contains the name presented in advertising data, as per Bluetooth core specification version, Vol. 3, Part C, Ch. 11.

11.2.4 Connection with central device

Once the BLE stack is placed in discoverable mode, it can be detected by a central device. The smartphone app described in [Section 11.1 BlueNRG app for smartphones](#) is designed for interact with the sensor profile demos (it also supports the BlueNRG-1 device).

Any Bluetooth Low Energy device like a smartphone can connect to the BLE sensor profile demo.

For example, the LightBlue application in Apple Store® connects iPhone® versions 4S/5 and above can connect to the sensor profile device. When you use the LightBlue application, detected devices appear on the screen with the BlueNRG name. By tapping on the box to connect to the device, a list of all the available services is shown on the screen; tapping a service shows the characteristics for that service.

The acceleration characteristic can be notified using the following command:

```
aci_gatt_update_char_value(accServHandle, accCharHandle, 0, 6, buff);
```

Where `buff` is a variable containing the three axes acceleration values.

Once this API command has been sent, the new value of the characteristic is displayed on the phone.

12 BLE sensor profile central demo

The BLE sensor profile central demo is supported on the [BlueNRG-1](#), [BlueNRG-2](#) development platforms (STEVAL-IDB007Vx, STEVAL-IDB008Vx, STEVAL-IDB009Vx). It implements a basic version of the BLE Sensor Profile Central role which emulates the Sensor Demo applications available for smartphones (iOS and android).

This application configures a BlueNRG-1, BlueNRG-2 device as a Sensor device, Central role which is able to find, connect and properly configure the free fall, acceleration and environment sensors characteristics provided by a BLE development platform configured as a BLE Sensor device, Peripheral role (refer to [Section 11 BLE sensor profile demo](#)).

This application uses a new set of APIs allowing to perform the following operations on a BlueNRG-1, BlueNRG-2 Master/Central device:

- Master Configuration Functions
- Master Device Discovery Functions
- Master Device Connection Functions
- Master Discovery Services, Characteristics Functions
- Master Data Exchange Functions
- Master Security Functions
- Master Common Services Functions

These APIs are provided through a binary library and they are fully documented on available doxygen documentation within the DK SW package. The following master/central binary libraries are provided in Library \BLE_Application\Profile_Central\library folder: libmaster_library_bluenrg1.a for IAR, Keil and Atollic toolchains on STSW-BLUENRG1-DK SW package.

13 BLE HID/HOGP demonstration application

The BLE HID/HOGP demonstration applications are supported by the [BlueNRG-1](#), [BlueNRG-2](#) development platforms (STEVAL-IDB007Vx, STEVAL-IDB008Vx, STEVAL-IDB009Vx). It demonstrates a BLE device using the standard HID/HOGP Bluetooth low energy application profile. Keyboard and mouse demo examples are provided.

13.1 BLE HID/HOGP mouse demonstration application

The BLE HID mouse application implements a basic HID mouse with two buttons compliant with the standard HID/HOGP BLE application profile.

The HID mouse device is named 'STMouse' in the central device list.

The mouse movements are provided by the 3D accelerometer and 3D gyroscope on the BLE development platform.

- The left button is the 'PUSH1' button.
- The right button is the 'PUSH2' button

If the HID mouse is not used for two minutes, it closes the connection and enters deep sleep mode. This idle connection timeout can be changed from the application. To exit deep sleep mode, press the left PUSH1 button or reset the platform.

13.2 BLE HID/HOGP keyboard demonstration application

The BLE HID keyboard application implements a basic HID keyboard compliant with the standard HID/HOGP BLE application profile.

The HID mouse device is named 'STKeyboard' in the central device list.

To successfully complete the bonding and pairing procedure, insert the PIN: 123456.

To use the HID keyboard:

- Connect the BLE development platform to a PC USB port
- Open a HyperTerminal window (115200, 8, N,1)
- Put the cursor focus on the HyperTerminal window
- The keys that are sent to the central device using the HID/HOGP BLE application profile are also shown on the HyperTerminal window

If the HID keyboard is not used for two minutes, it closes the connection and enters deep sleep mode. This idle connection timeout can be changed from the application. To exit deep sleep mode, press the left PUSH1 button or reset the platform.

14 BLE throughput demonstration application

The BLE throughput demonstration application provides some basic throughput demonstration applications to provide some reference figures regarding the achievable Bluetooth low energy data rate using the BlueNRG-1, BlueNRG-2 device.

The throughput application scenarios provided are:

1. Unidirectional scenario: the server device sends characteristic notifications to a client device.
2. Bidirectional scenario: the server device sends characteristic notifications to a client device and client device sends write without response characteristics to the server device.

The throughput application exposes one service with two (20 byte max.) characteristic values:

- The TX characteristic, with which the client can enable notifications; when the server has data to be sent, it sends notifications with the value of the TX characteristic.
- The RX characteristic, is a writable characteristic; when the client has data to be sent to the server, it writes a value in this characteristic.

The device roles which can be selected are:

1. Server, which exposes the service with the TX, RX characteristics (BLE peripheral device)
2. Client, which uses the service TX, RX characteristics (BLE central device).

Each device role has two instances for each throughput scenario (unidirectional, bidirectional).

The BLE throughput demonstration applications are supported by the BlueNRG-1, BlueNRG-2 development platforms (STVAL-IDB007Vx, STVAL-IDB008Vx, STVAL-IDB009Vx).

14.1 BLE unidirectional throughput scenario

The unidirectional throughput scenario lets you perform a unidirectional throughput test where a server device sends notification to a client device.

To run this scenario:

- Program the client unidirectional application on one BLE platform and reset it. The platform is seen on the PC as a virtual COM port.
- Open the port in a serial terminal emulator (the required serial port baudrate is 921600)
- Program the server unidirectional application on a second BLE platform and reset it.
- The two platforms try to establish a connection; if successful, the slave continuously sends notifications of TX characteristic (20 bytes) to the client.
- After every 500 packets, the measured application unidirectional throughput is displayed.

14.2 BLE bidirectional throughput scenario

The bidirectional throughput scenario lets you perform a bidirectional throughput test where the server device sends notifications to a client device and client device sends write without response characteristics to the server device.

To run this scenario:

- Program the client bidirectional application on one BLE platform and reset it. The platform is seen on the PC as a virtual COM port.
- Open the related port in a serial terminal emulator (the required serial port baudrate is 921600)
- Program the server bidirectional application on a second BLE platform and reset it.
- Open the related port in a serial terminal emulator (the required serial port baudrate is 921600)
- The two platforms try to establish a connection; if successful, the slave device continuously sends notifications of TX characteristic (20 bytes) to the client device and the client device continuously sends write without responses of the RX characteristic (20 bytes) to the server device.
- After every 500 packets, the measured application bidirectional throughput is displayed.

Note: For *BlueNRG-2*, BLE stack v2.1 or later, a further BLE throughput demonstration application (with data length extension up to 251 bytes) is provided. The application allows displaying the throughput data in a unidirectional flow (the server sends notifications to the client) or a bidirectional flow (the server sends notifications to the client and the client writes without response operations on the server). The server can perform an ATT_MTU exchange operation to increase the ATT_MTU size to 247 bytes. The user can also directly set the actual data length value up to 247 bytes.

15 BLE notification consumer demonstration application

The BLE ANCS demonstration application configures a [BlueNRG-1](#), [BlueNRG-2](#) device as a BLE notification consumer, which facilitates Bluetooth accessory access to the many notifications generated on a notification provider.

After reset, the demo places the BLE device in advertising with device name "ANCSdemo" and sets the BlueNRG-1 authentication requirements to enable bonding.

When the device is connected and bonded with a notification provider, the demo configures the BLE notification consumer device to discover the service and the characteristics of the notification provider. When the setup phase is complete, the BLE device is configured as a notification consumer able to receive the notifications sent from the notification provider.

The BLE notification consumer demonstration application is supported by the BlueNRG-1, BlueNRG-2 development platforms (STEVAL-IDB007Vx, STEVAL-IDB008Vx, STEVAL-IDB009Vx).

16 BLE security demonstration applications

The BLE Security demonstration applications are supported by the [BlueNRG-1](#), [BlueNRG-2](#) development platforms (STEVAL-IDB007Vx, STEVAL-IDB008Vx). They provide some basic examples about how to configure, respectively, two BLE devices as a Central and Peripheral, and setup a secure connection by performing a BLE pairing procedure. Once paired the two devices are also bonded.

The following pairing key generation methods are showed:

- PassKey entry with random pin
- PassKey entry with fixed pin
- Just works
- Numeric Comparison (new pairing method supported only from BlueNRG-1, BlueNRG-2 BLE stack v2.x)

For each pairing key generation method, a specific project security configuration is provided for both Central & Peripheral device as shown in the following [Table 8. BLE security demonstration applications security configurations combinations](#). Each Central and Peripheral device must be loaded, respectively, with the application image targeting the proper security configuration, to correctly demonstrate the associated BLE security pairing functionality.

Table 8. BLE security demonstration applications security configurations combinations

Pairing key generation method	Central device security configuration	Peripheral device security configuration
PassKey entry with random pin	Master_PassKey_Random	Slave_PassKey_Random
PassKey entry with fixed pin	Master_PassKey_Fixed	Slave_PassKey_Fixed
Just works	Master_JustWorks	Slave_JustWorks
Numeric Comparison	Master_NumericComp	Slave_NumericComp

16.1 Peripheral device

On reset, after initialization, Peripheral device sets security IO capability and authentication requirements, in order to address the selected pairing key generation method, in combinations with the related security settings of the Central device.

After initialization phase, Peripheral device also defines a custom service with 2 proprietary characteristics (UUID 128 bits):

- TX characteristic: notification (`CHAR_PROP_NOTIFY`),
- RX characteristic with properties: read (`CHAR_PROP_READ`, `GATT_NOTIFY_READ_REQ_AND_WAIT_FOR_APPL_RES`) (application is notified when a read request of any type is received for this attribute).

Based on the selected security configuration, the RX characteristic is defined with proper security permission (link must be "encrypted to read" on JustWorks method, link must be "encrypted to read and need authentication to read" on all other methods).

The Peripheral device enters in discovery mode with local name `SlaveSec_Ax` (x= 0,1,2,3 depending on the selected security configuration).

Table 9. Peripheral device advertising local name parameter value

Peripheral device configuration	Advertising local name	Pairing method
Slave_JustWorks	SlaveSec_A0	Just works
Slave_PassKey_Fixed	SlaveSec_A1	PassKey entry with fixed pin
Slave_PassKey_Random	SlaveSec_A2	PassKey entry with random pin
Slave_NumericComp	SlaveSec_A3	Numeric Comparison

When a Central device starts the discovery procedure and detects the Peripheral device, the two devices connects.

After connection, Peripheral device starts a slave security request to the Central device `aci_gap_slave_security_req()` and , as consequence, Central devices starts pairing procedure.

Based on the pairing key generation method, user could be asked to perform some actions (i.e. confirm the numeric value if the numeric comparison configuration is selected, add the key, displayed on Peripheral device, on Central hyper terminal, if the passkey entry with random pin configuration is selected).

After devices pairs and get bonded, Peripheral device displays the list of its bonded devices and configures its white list in order to add the bonded Central device to its white list `aci_gap_configure_whitelist()` API.

Central devices starts the service discovery procedure to identify the Peripheral service and characteristics and, then, enabling the TX characteristic notification.

Peripheral device starts TX characteristic notification to the Central device at periodic interval, and it provides the RX characteristic value to the Central device each time it reads it.

When connected, if user presses the BLE platform button PUSH1, Peripheral device disconnects and enters undirected connectable mode mode with advertising filter enabled (`WHITE_LIST_FOR_ALL`: Process scan and connection requests only from devices in the white list). This implies that Peripheral device accepts connection requests only from devices on its white list: Central device is still be able to connect to the Peripheral device; any other device connection requests are not accepted from the Peripheral device.

TX and RX characteristics length is 20 bytes and related values are defined as follow: - TX characteristic value:

```
{'S','L','A','V','E','_','S','E','C','U','R','I','T','Y','_','T','X',' ',x1,x2};
```

where x1, x2 are counter values - RX characteristic value:

```
{'S','L','A','V','E','_','S','E','C','U','R','I','T','Y','_','R','X',' ',x1,x2};
```

where x1, x2 are counter values

16.2 Central device

On reset, after initialization, Central device uses the `Master_SecuritySet()` API for setting the security IO capability and authentication requirements in order to address the specific selected pairing method, in combinations with the related security settings of the Central device. Central device application is using the Central/Master library APIs and callbacks for performing the Central device BLE operations (device discovery, connection, ...).

Central device starts a device discovery procedure (`Master_DeviceDiscovery()` API, looking for the associated Peripheral device `SlaveSec_Ax` (x= 0,1,2,3 : refer to [Table 9. Peripheral device advertising local name parameter value](#)).

When found, Central connects to the Peripheral device. In order to start the pairing, Central device is expecting the Peripheral device to send a slave security request. Once the security request is received, Central device starts the pairing procedure. Based on the pairing key generation method, user could be asked to perform some actions (i.e. confirm the numeric value if the numeric comparison configuration is selected, add the key, displayed on Peripheral device, on Central hyper terminal, if the passkey entry with random pin configuration is selected). Once the pairing and bonding procedure has been completed, the Central device starts the service discovery procedure in order to find the Peripheral TX & RX characteristics.

After Service Discovery, Central enables the TX characteristic notification. Then the Central device receives periodically the TX characteristic notification value from Peripheral device and read the related RX characteristic value from Peripheral device.

When connected, if user presses the BLE platform PUSH1 button, the Central device disconnects and reconnect to the Peripheral device which enters in undirected connectable mode with advertising filter enabled. Once connected to the Peripheral device, it enters again on the TX characteristic notification/RX characteristic read cycle.

Note: When using a smartphone as Central device, if this device uses a random resolvable address, the Peripheral device is not able to accept connection or scan requests coming from it, during the reconnection phase. This is due to the fact that, when disconnecting, the Peripheral device enters the undirected connectable mode with filtering enabled (WHITE_LIST_FOR_ALL: process scan and connection requests from the White List devices only). As a consequence, it is able to accept the smartphone scan or connection requests, only if the Privacy Controller is enabled on the Peripheral device.

A possible simple alternative is to replace, on the Peripheral device, the WHITE_LIST_FOR_ALL advertising filter policy with NO_WHITE_LIST_USE: the Peripheral device does not enable device filtering after reconnection, and it is able to accept connection or scan requests coming from a smartphone by using resolvable random addresses.

17 BLE power consumption demo application

The BLE power consumption demo application allows putting the selected BLE device in discovery mode: you can choose from a test menu which advertising interval to use (100 ms or 1000 ms). To measure the BlueNRG-1, BlueNRG-2 current consumption, it is necessary to connect a DC power analyzer to the JP4 connector of the STEVAL-IDB007Vx, STEVAL-IDB008Vx, STEVAL-IDB009Vx kit platforms. Then, you can set a connection up with another device configured as a master and measure the related power consumption.

The master role can be covered by another BlueNRG-1, BlueNRG-2 kit platform configured with the DTM FW application (DTM_UART.hex) and running a specific script through the BlueNRG GUI or Script launcher PC applications.

In the BLE_Power_Consumption demo application project folder, two scripts are provided to configure the master device and create a connection with the BlueNRG-1, 2 kit platform under test.

The two scripts allow establishing a connection with 100 ms and 1000 ms as connection intervals, respectively.

The power consumption demo supports some test commands:

- f: the device is in discoverable mode with a fast interval of 100 ms
- s: the device is in discoverable mode with a slow interval of 1000 ms
- r: to reset the BlueNRG-1
- ?: to display the help menu

Note: This demo application is available only on BlueNRG-1_2 DK SW package (STSW-BLUENRG1-DK) supporting BLE stack v2.x family.

18 BLE master and slave multiple connection demonstration application

This application provides a basic example of multiple connections scenario: a device configured as master and slave which uses a specific formula to calculate the proper advertising, scanning and connection parameters for handling, at same time, BLE connections with slave and master devices.

It is supported by the [BlueNRG-1](#), [BlueNRG-2](#) development platforms (STEVAL-IDB007Vx, STEVAL-IDB008Vx, STEVAL-IDB009Vx).

18.1 Application roles

The demonstration application defines two device roles:

1. Master_Slave device role
2. Master device role

The slave devices can be configured through the `Slaves_Num_Slaves.py` python script, provided in the application src folder, and using the BlueNRG Script Launcher utility available in the [STSW-BNRGUI](#) software package.

18.1.1 Master_Slave device role

The Master_Slave device role allows testing a multiple connection scenario using the `GET_Master_Slave_device_connection_parameters()` formula provided in the `ble_utils.c` file.

This role configures the Master_Slave device as Central and Peripheral with one service and one characteristic, and it simultaneously advertises and scans to connect to up to *Num_Slaves BLE Peripheral/Slave devices Slave1, Slave2, ...* (which have defined the same service and characteristic) and to up to *Num_Masters Central/Master devices*, respectively.

The *Num_Slaves* depends on the max. number of supported multiple connections (8) and the *Num_Masters* [0-2] of the selected Master devices, that is: $Num_Slaves = 8 - Num_Masters$.

The user must define the expected number of slaves and master devices, by setting the pre-processor options:

- `MASTER_SLAVE_NUM_MASTERS`
- `MASTER_SLAVE_NUM_SLAVES`

The user can also set the requested minimal scan window and additional sleep time, respectively, through the preprocessor options:

- `MASTER_SLAVE_SCAN_WINDOW`
- `MASTER_SLAVE_SLEEP_TIME`

Note: *The default configuration is:*

- *Num_Masters = 1*
- *Num_Slaves = 6*
- *Slave_Scan_Window_Length = 20*
- *Slave_Sleep_time = 0*

Once slaves and devices are connected, the BLE Master_Slave device receives characteristic notifications from *Num_Slaves* devices and it also notifies characteristics (as Peripheral) to the *Num_Masters* BLE Master devices (if any) which display the related received slave index value.

Num_Slaves devices notified characteristic value is: `<slave_index><counter_value>`, where *slave_index* is one byte in the range [1 - *Num_Slaves*] and *counter_value* is a two-byte counter starting from 0.

18.1.2 Master role

The master device role simply configures a [BlueNRG-1](#), [BlueNRG-2](#) device as a Master device looking for the Master_Slave device in advertising with the advertising name of *advscan*.

Once the Master device finds the *advscan* device, it establishes a connection to it and enables the characteristic notification. Notifications from *Num_Slaves* devices are notified to the Master device through the Master_Slave device.

19 BLE Controller Privacy demonstration application

This application provides a basic example of Bluetooth low energy controller privacy feature with BLE master and slave devices. Controller Privacy requires 32 MHz high speed crystal on the selected platforms.

It is supported by the BlueNRG-2 development platforms (STEVAL-IDB007Vx, STEVAL-IDB008Vx, STEVAL-IDB009Vx).

19.1 Application scenario

The application scenario is based on two devices, master and slave, configured with `aci_gap_init(privacy_flag = 0x02)`, which should perform the following macro steps:

1. Initially, master and slave devices have no info on their security database: the two devices should connect and make a pairing and bonding (fixed key: 123456).
2. Once the bonding is completed, the slave calls the `aci_gap_configure_white_list()` API to add its bonded device address to the controller's white list.
3. Both devices add their bonded device address and type to the list of resolvable addresses by using the API `aci_gap_add_devices_to_resolving_list()`.
4. The master device enables the slave characteristic notification. After the first connection and the pairing/bonding phase, devices disconnect.
5. The slave enters undirected connectable mode (`aci_gap_set_undirected_connectable()` API) with its own address type = resolvable address and white list = 0x03 as advertising filter policy.
6. The master device performs a direct connection to the detected slave device, which accepts the connection since the master address is on its white list: the two devices reconnect and the slave starts a notification cycle to the master.

Note: When the connection is established, if you press the BLE platform button PUSH1 on one of the two devices, it disconnects and the slave enters the undirected connectable mode with filtering enabled (WHITE_LIST_FOR_ALL). This implies that the slave device accepts connection requests only from devices on its white list: the master device is still able to connect to the slave device; any other device connection request is not accepted from the slave device.

20 BlueNRG-1, BlueNRG-2 peripheral driver examples

The BlueNRG-1, BlueNRG-2 peripheral driver examples applications are supported respectively by the BlueNRG-1, BlueNRG-2 development platforms (STEVAL-IDB007Vx, STEVAL-IDB008Vx, STEVAL-IDB009Vx). The kit contains a set of examples demonstrating how to use the BlueNRG-1, BlueNRG-2 device peripheral drivers ADC, GPIOs, I²C, RTC, SPI, Timers, UART and WDG.

Note: On all the following sub-sections, any reference to the BlueNRG-1 device and the related kit platform STEVAL-IDB007Vx (with x=1, 2) is also valid for the BlueNRG-2 device and the related kit platform STEVAL-IDB008Vx (with x=1, 2) and STEVAL-IDB009Vx (x =1).

20.1 ADC examples

ADC polling: conversion is managed through the polling of the status register. The systick timer is used to have a delay of 100 ms between two samples. Each sample from ADC is printed through UART (USB-to-SERIAL must be connected to the PC). The default input is the differential ADC1-ADC2.

ADC DMA: conversion is managed through the ADC DMA channel. The systick timer is used to have a delay of 100 ms between two samples. Each sample from ADC is printed through UART (USB-to-SERIAL must be connected to the PC).

ADC PDM: this example shows a PDM stream processor from a MEMS microphone (MP34DT01-M) to UART. The application also supports the MP34DT01-M MEMS microphone available on the X-NUCLEO-CCA02M1 evaluation board (refer to the related BlueNRG-1 DK software package ADC PDM doxygen documentation for hardware connection setup).

You are requested to connect the BLE platform to a PC USB port and open PuTTY serial terminal [512000, 8-N-1-N], which has to be configured to store the captured data in a log file.

After the data have been captured, the PC Audacity tool can be opened to import the streamed data, following these steps:

- File/Import/Raw Data.
- Open the log data.
- Configure as follows:
 - Encoding: Signed 16-bit PCM.
 - Byte order: Little-endian.
 - Channels: 1 Channel (Mono).
 - Sample rate: 8000 (default, 16 kbps is supported by changing the firmware symbol FS in ADC_PDM_main.c)
 - Press the button Import.
- Play the audio.

Note: As the output data format is two-bytes (B1B2), the serial terminal might get, as first byte, half data (B2). Therefore, this first byte must be removed from the log file.

20.2 Flash example

Data storage: demonstrates basic flash operations as erase, write and verification.

20.3 GPIO examples

Input interrupt: demonstrates the use of GPIO input interrupts.

- The PUSH1 button (IO13) is configured to generate the interrupt event on both edges of the input signal. LED DL1 is toggled ON if the level is high and OFF if low.
- The PUSH2 button (IO5) is configured to generate the interrupt event on the rising edge of the input signal. LED DL2 is toggled ON/OFF at each rising edge event.

IO toggle: demonstrates GPIO state changes by toggling LEDs DL1 and DL2 every 500 ms.

IO wakeup: demonstrates device wakeup from standby mode using the GPIO interrupt.

- The PUSH1 button (IO13) is configured to generate the interrupt event on both edges of the input signal. LED DL2 is toggled, the system becomes active and LED DL1 is toggled by the systick interrupt service routine every 500 ms.

Once the device is in standby, you cannot open a connection with the debug tool or download new code as the clocks are down and the system voltages are at their minimum values. Therefore, it is necessary to wake the system up via the IO9 (SDW clock signal) wake-up event. In this case, any connection attempt from the debugger wakes the system up.

20.4 I²C examples

In all the following examples, I²C is configured in master mode and its clock frequency is set to 10 kHz.

Master polling: I²C communication is controlled by polling the I²C status register content. This example involves a master board with Master_Polling firmware code and a slave board with Slave_Polling firmware.

The Master board has a small command line interface through UART (USB-to-SERIAL must be connected to the PC), which you can use to read and change the LED status of the slave board. I²C is used to transfer information and change the status of the LEDs on the slave board.

Slave polling: I²C communication is controlled by polling the I²C status register content. This also involves a master and a slave board with respective Master_Polling and Slave_Polling firmware. The slave board receives read and change requests for the LEDs via I²C.

Master sensor: I²C communication is controlled by polling of I²C status register content, interrupts or DMA (three different configurations). In this example, the LPS25HB environmental sensor is configured to provide output data at 1 Hz. The BlueNRG-1 polls the sensor status register and prints available pressure and temperature data via UART (USB-to-SERIAL must be connected to the PC).

20.5 Micro examples

Hello world: example for the basic 'BlueNRG-1 Hello World' application. Connect the BlueNRG-1 platform to a PC USB port and open a specific PC tool/program (like Tera Term): the "Hello World: BlueNRG-1 is here!" message is displayed.

Sleep test: this test provides an example for the following BlueNRG-1 sleep modes:

- SLEEPMODE_WAKETIMER places the BlueNRG-1 in deep sleep with the timer clock sources running. The wakeup sources type any character on the keyboard, the PUSH1 button or the sleep timer are configured with a timeout of 5 s.
- SLEEPMODE_NOTIMER places the BlueNRG-1 in deep sleep with the sleep timer clock sources turned off. Only the wakeup sources and the PUSH1 button type any character on the keyboard.

The demo supports some user commands:

- **s:** SLEEPMODE_NOTIMER - wakes UART/PUSH1 on
- **t:** SLEEPMODE_WAKETIMER - wakes UART/timeout 5 s/PUSH1 on
- **l:** toggles LED DL1
- **p:** prints the 'Hello World' message
- **r:** resets the BlueNRG-1 device
- **?:** displays the help menu
- **PUSH1:** toggles LED DL1

20.6 Public Key Accelerator (PKA) demonstration application

The BlueNRG-1 PKA demonstration application is supported by the BlueNRG-1, BlueNRG-2 development platforms. It provides a basic example on how to use the available PKA driver APIs to perform a basic PKA processing and check the results.

The Public Key Accelerator (PKA) is a dedicated hardware block used for computation of cryptographic public key primitives related to ECC (Elliptic curve cryptography).

Note: This peripheral is used by the BlueNRG-1, BlueNRG-2 Bluetooth low energy stack during the security pairing procedures, so the user application must not use it in the meantime.

The PKA demonstration application performs the following steps:

1. Starting from the PKA known point on the ellipse `PKS_SetData()` with `PKA_DATA_PCX`, `PKA_DATA_PCY` and from a random generated keyA, it performs a PKA process which generates a new point A on the ellipse.
2. The same process is repeated from a new generated random keyB, leading to a new point B on the ellipse.
3. A new PKA process starts using the keyA with the point B coordinates. This generates a new point C which is still on the same ellipse.

20.7 2.4 GHz radio proprietary examples

The radio low level driver provides access to the BlueNRG-1, 2 device 2.4 GHz radio to send and receive packets without using the Bluetooth link layer.

The available 2.4 GHz radio proprietary examples are:

- **AutomaticChMgm**, a TX only example where the ActionTag `INC_CHAN` is used to automatically change the channel.
- **Beep**, a TX only example where the device continuously sends a packet in three different channels.
- **BeepMultiState**, a TX only example with multi state functionality.
- **Chat**, point-to-point communication generating a two-way chat.
- **ChatEncrypt**, as the previous example, but with the encryption enabled.
- **RemoteControl**, a basic remote control scenario; by pressing the `PUSH1` button on the device makes toggle the `LED1` on the receiver device.
- **Sleep**, demonstrates point-to-point communication with sleep management.
- **Sniffer**, a sniffer application in a selected channel and a defined `NetworkID`.
- **SnifferMultiState**, a sniffer application with multi state functionality.
- **StarNetwork**, a star network example where a Master asks for packets to the slaves of the network.
- **TxRx**, point-to-point communication with computation of packet error rate (PER).
- **TxRxDoublePacket**, point-to-point communication where a payload greater than 32 bytes is exchanged.
- **Throughput TX, RX**, throughput test example (unidirectional with one TX and one RX device, and bidirectional with two TX devices and one RX device)
- **OTA Client, Server**, 2.4 GHz proprietary radio demonstration application showing the 2.4 GHz proprietary radio Over-the-Air FW upgrade support functionality (Client and Server configurations)

20.8 RNG examples

Terminal: shows how to use the RNG. It gets the RNG values and prints them on the terminal.

20.9 RTC examples

Clock watch: implements both RTC timer and RTC clockwatch.

The RTC timer generates the 500 ms interrupt interval. The `LED DL1` state is toggled in the RTC interrupt handler to signal proper RTC timer operation.

The RTC clockwatch is also enabled with the system time and date set to December 1st 2014, 23 h 59 m 31 s. The RTC clockwatch match registers are then set to December 2nd 2014, 0 h 0 m 1 s. As soon as the RTC clockwatch data register and match registers coincide (30 s after device power up), the RTC clockwatch match interrupt is generated and `LED DL2` is toggled to signal the event.

Time base: the RTC is configured in the periodic timer mode, the load register (`RTC_TLR1`) value is set and the RTC is enabled. Whenever the RTC timer reaches the value `0x00`, it generates an interrupt event and the timer value is automatically reloaded from the `RTC_TLR1` register, which is set to generate the interrupt every 1 s. The `LED DL1` is toggled at each interrupt event.

Time base pattern: periodic mode is used with a pattern configuration. The RTC is configured in the periodic timer mode and register `RTC_TLR1` is set to generate a 1 s interval, while `RTC_TLR2` is set to generate a 100 ms interval.

The RTC is then enabled and, whenever the RTC timer reaches the value `0x00`, it generates an interrupt and the timer value is automatically reloaded from register `RTC_TLR1` or `RTC_TLR2` register depending on the pattern register setting.

The pattern is set to 0b11110010 and its size to 8 bits, so the RTC generates four intervals with the RTC_TLR1 value followed by two RTC_TLR2 value intervals. The pattern repeats itself and the RTC interrupt routine toggles LED DL1 (IO6).

RTC virtual timer: it shows how to emulate an RTC using the virtual timer (working on sleeping mode). The virtual timer is used to wait for 30 seconds, then LED2 turns on and the application stops. Sleep mode is used. A wakeup handled by the BLE stack is generated every 10.24 seconds.

20.10 SPI examples

The following SPI application examples are available:

Master polling: involves a master board with the Master_Polling firmware code and a slave board with the Slave_Polling firmware. The Master board has a small command line interface through UART (USB-to-SERIAL must be connected to the PC), which you can use to read and change the LED status of the slave board via SPI. The SPI is configured in master mode and the SPI clock set to 100 kHz. The data is transferred in the Motorola format with an 8-bit data frame, with clock low when inactive (CPOL=0) and data valid on clock trailing edge (CPHA = 1).

Slave polling: SPI communication is controlled by polling the SPI status register content. This also involves a master and a slave board with respective Master_Polling and Slave_Polling firmware. The slave board receives read and change requests for the LEDs via SPI.

The SPI is configured in slave mode and the SPI clock set to 100 kHz. The data is transferred in the Motorola format with an 8-bit data frame, with clock low when inactive (CPOL=0) and data valid on clock trailing edge (CPHA = 1).

Master sensor: SPI communication is controlled by polling of the SPI status register content, interrupts or DMA (3 different configurations). SPI is used to communicate with the [LSM6DS3](#) inertial sensor SPI interface. Whenever the sensor generates an IRQ, the accelerometer and gyroscope output data are read and printed through UART (USB-to-SERIAL must be connected to the PC).

The SPI is configured in master mode and the SPI clock set to 100 kHz. The data is transferred in the Motorola format with an 8-bit data frame, with clock low when inactive (CPOL=0) and data valid on clock trailing edge (CPHA = 1).

Master DMA: SPI communication is controlled by DMA of the SPI status register content. It involves a master board with the Master_Dma firmware code and a slave board with the Slave_Dma firmware. The Master board has a small command line interface through UART (USB-to-SERIAL must be connected to the PC), which you can use to read and change the LED status of the slave board via SPI.

The SPI is configured in master mode and the SPI clock set to 100 kHz. The data is transferred in the Motorola format with an 8-bit data frame, with clock low when inactive (CPOL=0) and data valid on clock trailing edge (CPHA = 1).

Slave DMA: SPI communication is controlled by DMA of the SPI status register content. It involves a master board with the Master_Dma firmware code and a slave board with the Slave_Dma firmware. The slave board receives read and change requests for the LEDs via SPI.

The SPI is configured in slave mode and the SPI clock set to 100 kHz. The data is transferred in the Motorola format with an 8-bit data frame, with clock low when inactive (CPOL=0) and data valid on clock trailing edge (CPHA = 1).

SPI 3 wires: demonstrates the SPI 3 wires communication for reading humidity and temperature data from the [HTS221](#) humidity sensor. In this example, the evaluation board for HTS221, [STEVAL-MKI141V2](#), is used. The SPI clock frequency is set to 100 kHz. The data is transferred in the Microwire format and the data frame size is 8 bits.

20.11 SysTick examples

Time base: the interrupt service routine toggles the user LEDs at approximately 0.5 s intervals.

20.12 Timers examples

Mode 1: Timer/Counter 1 (TnCNT1) functions as the time base for the PWM timer and counts down at the clock rate selected by the Timer/Counter 1 clock selector. When an underflow occurs, the timer register is reloaded alternately from the TnCRA (first reload) and TnCRB registers and count down begins from the loaded value.

Timer/Counter 2 can be used as a simple system timer, an external-event counter, or a pulse-accumulate counter. Counter TnCNT2 counts down with the clock selected by the Timer/Counter 2 clock selector, and can be configured to generate an interrupt upon underflow.

MFTX1 and MFTX2 use prescaled clock as Timer/Counter 1. The IO2 pin is configured as output, generating a signal with 250 ms positive level and 500 ms negative level via MFTX1. The IO3 pin is configured as output, generating a signal with 50 ms positive level and 100 ms negative level via MFTX2.

Timer/Counter 1 interrupts upon reload are enabled for MFTX1 and MFTX2; interrupt routines toggle LED DL1 for MFTX1 and LED DL2 for MFTX2.

Mode 1a (pulse-train mode): the Timer/Counter 1 functions as PWM timer and Timer/Counter 2 is used as a pulse counter that defines the number of pulses to be generated.

In this example, MFTX2 is configured to generate 30 pulses with positive level of 500 ms and negative level of 250 ms. MFTX2 uses prescaled clock as Timer/Counter 1. The IO3 pin is configured as output generating the number of pulses configured.

Interrupts TnA and TnB are enabled and toggle GPIO 8 and 10, while Interrupt TnD is enabled and sets GPIO 7.

A software start trigger or external rising or falling edge start trigger can be selected. This example uses a software trigger which is generated after system configuration.

Timer/Counter 1 interrupts on reload are enabled for MFTX1. Interrupt routines toggle LED DL1 for MFTX2.

Mode 2 (dual-input capture mode): Timer/Counter 1 counts down with the selected clock and TnA and TnB pins function as capture inputs. Transitions received on the TnA and TnB pins trigger a transfer of timer content to the TnCRA and TnCRB registers, respectively. Timer/Counter 2 counts down with selected clock and can generate an interrupt on underflow.

In this example, MFTX1 is used. The CPU clock is selected as the clock signal for Timer/Counter 1 and a Prescaled clock is used as the clock source for Timer/Counter 2.

Sensitivity to falling edge is selected for TnA and TnB inputs; counter preset to 0xFFFF is disabled for both inputs. The IO2 pin is internally connected to TnA input (MFTX1) and the IO3 pin is internally connected to TnB input (MFTX1).

Interrupts TnA and TnB are enabled and triggered by transitions on pins TnA and TnB, respectively. The interrupt routine records the value of TnCRA or TnCRB and calculates the period of the input signal every second interrupt.

Interrupt TnC is enabled and is triggered on each underflow of Timer/Counter1; it increments the underflow counter variables used to calculate the input signal period.

LED DL1 is toggled ON if a frequency of about 1 kHz is detected on IO2, and LED DL2 is toggled ON if a frequency of about 10 kHz is detected on IO3.

Mode 3 (dual independent timer/counter): the timer/counter is configured to operate as a dual independent system timer or dual external-event counter. Timer/Counter 1 can also generate a 50% duty cycle PWM signal on the TnA pin, while the TnB pin can be used as an external-event input or pulse-accumulate input, and serve as the clock source to either Timer/Counter 1 or Timer/Counter 2. Both counters can also be operated from the prescaled system clock.

In this example MFTX1 is used. The CPU clock is selected as the clock signal for Timer/Counter 1, while Timer/Counter 2 uses an external clock on TnB pin. Sensitivity to rising edge is selected for TnB input. Timer/Counter 1 is preset and reloaded to 5000, so the frequency of the output signal is 1 kHz. Timer/Counter 2 is preset and reloaded to 5.

The IO3 pin is internally connected to TnA input (MFTX1), while the IO2 pin is configured as output and configured as the PWM output from Timer/Counter 1.

The LED DL1 is toggled in the main program according to a variable which is changed in TnD interrupt routine. Interrupt TnA and TnD are enabled and are triggered on the underflow of Timer/Counter1 and Timer/Counter2 respectively.

Mode 4 (input-capture plus timer): is a combination of mode 3 and mode 2, and makes it possible to operate Timer/Counter 2 as a single input-capture timer, while Timer/Counter 1 can be used as a system timer as described above.

In this example, MFTX1 is used. The CPU clock is selected as the input clock for Timer/Counter 1 and Timer/Counter 2. Automatic preset is enabled for Timer/Counter 2.

The IO2 pin is internally connected to the TnB input (MFTX1), while the IO3 pin is configured as the output and configured as the PWM output from Timer/Counter 1.

Interrupt TnA is enabled and triggered on the underflow of Timer/Counter1; it sets a new value in the TnCRA register. Interrupt TnB is enabled and triggered when a transition on TnB input (input capture) is detected; it saves the TnCRB value. Interrupt TnD is enabled and it triggered on the underflow of Timer/Counter2.

MFT timers: this example shows how configure peripherals MFT1, MFT2 and SysTick to generate three timer interrupts at different rate: MFT1 at 500 ms, MFT2 at 250 ms and SysTick at 1 second.

Software PWM signals: this example shows how three independent PWM signals can be generated driving GPIO pins inside MFT interrupt handlers.

20.13 UART examples

DMA: IO8 and IO11 are configured as UART pins and DMA receive and transmit requests are enabled. Each byte received from UART is sent back through UART in an echo application (USB-to-SERIAL must be connected to the PC).

Interrupt: IO8 and IO11 are configured as UART pins and receive and transmit interrupts are enabled. Each byte received from UART is sent back through UART in an echo application (USB-to-SERIAL must be connected to the PC).

Polling: IO8 and IO11 are configured as UART pins. Each byte received from UART is sent back through UART in an echo application (USB-to-SERIAL must be connected to the PC).

RXTimeout: it demonstrates the UART RX FIFO level and RX timeout functionality. The demo prints the data received if the RX timeout expires or if the data received are \geq the RX FIFO threshold.

20.14 WDG examples

Reset: demonstrates the watchdog functionality and using it to reboot the system when the watchdog interrupt is not serviced during the watchdog period (interrupt status flag is not cleared).

The watchdog is configured to generate the interrupt with a 15 s interval, then it is enabled and monitors the state of the PUSH1 button (IO13 pin). Any change on this pin triggers the watchdog counter to reload and restart the 15 s interval measurement.

If the IO13 pin state does not change during this interval, the watchdog generates an interrupt that is intentionally not cleared and therefore remains pending; the watchdog interrupt service routine is therefore called continuously and the system is stuck in the watchdog interrupt handler.

The chip is reset as it can no longer execute user code. The second watchdog timeout triggers system reboot as a new watchdog interrupt is generated while the previous interrupt is still pending. The application then starts measuring the 15 s interval again.

The three user LEDs are toggled at increasing frequencies until the board is reset or PUSH1 button is pressed, which restores the LEDs toggling frequency with the 15 s watchdog timer.

Wakeup: The watchdog timer is a 32-bit down counter that divides the clock input (32.768 kHz) and produces an interrupt whenever the counter reaches zero. The counter is then reloaded with the content of the WDT_LR register. If the interrupt status flag is not cleared and a new interrupt is generated, then the watchdog may generate a system reset.

This example demonstrates the use of the watchdog to periodically wake the system from standby mode using the watchdog interrupt. The watchdog is configured to generate the interrupt at 1 s intervals. The watchdog is then enabled and the system is switched to the standby mode. As soon as the watchdog interrupt is generated, the system wakes up, LED1 (IO6 pin) is toggled and the device returns to standby mode. The IO6 pin is therefore toggled every 1 s.

21.1 STEVAL-IDB007V1 schematic digrams

Figure 24. STEVAL-IDB007V1 Arduino connectors

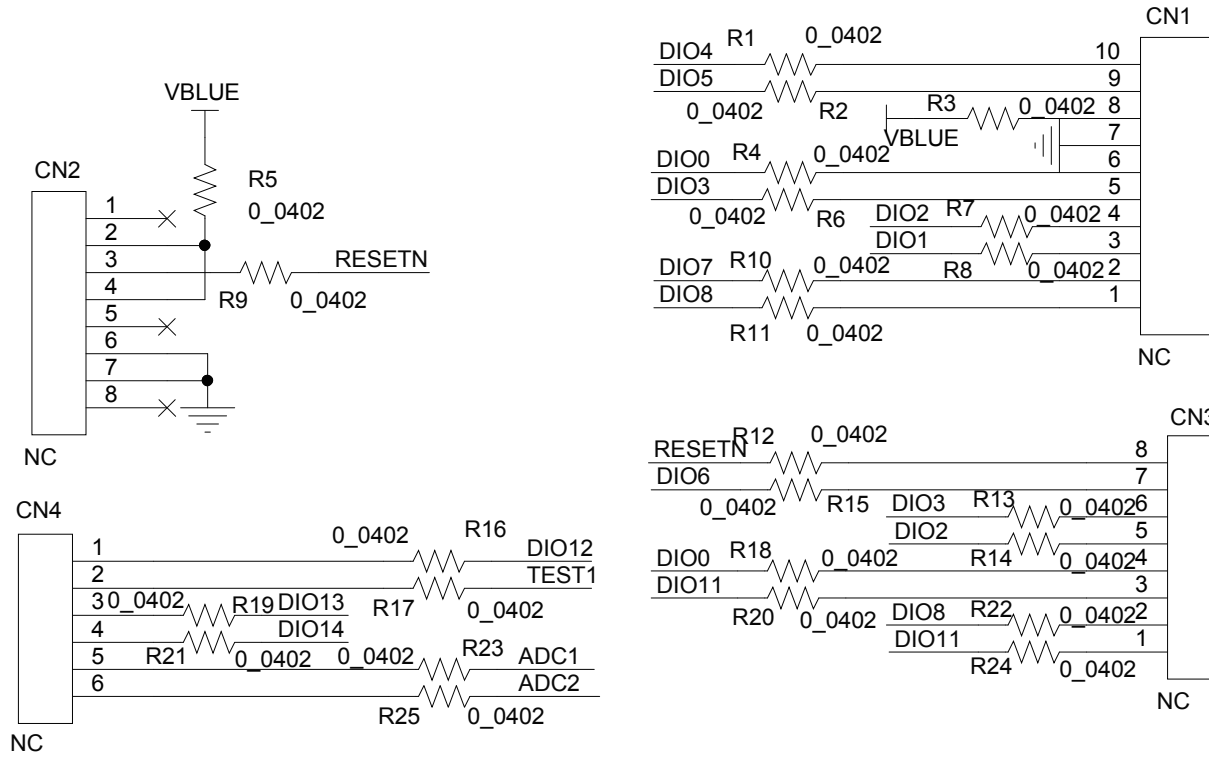

Figure 25. STEVAL-IDB007V1 JTAG

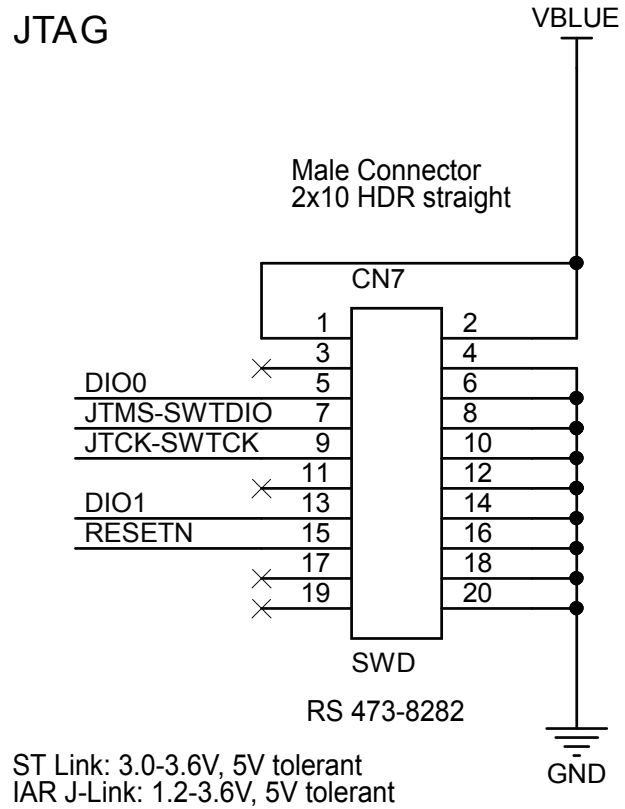

Figure 26. STEVAL-IDB007V1 BlueNRG-1

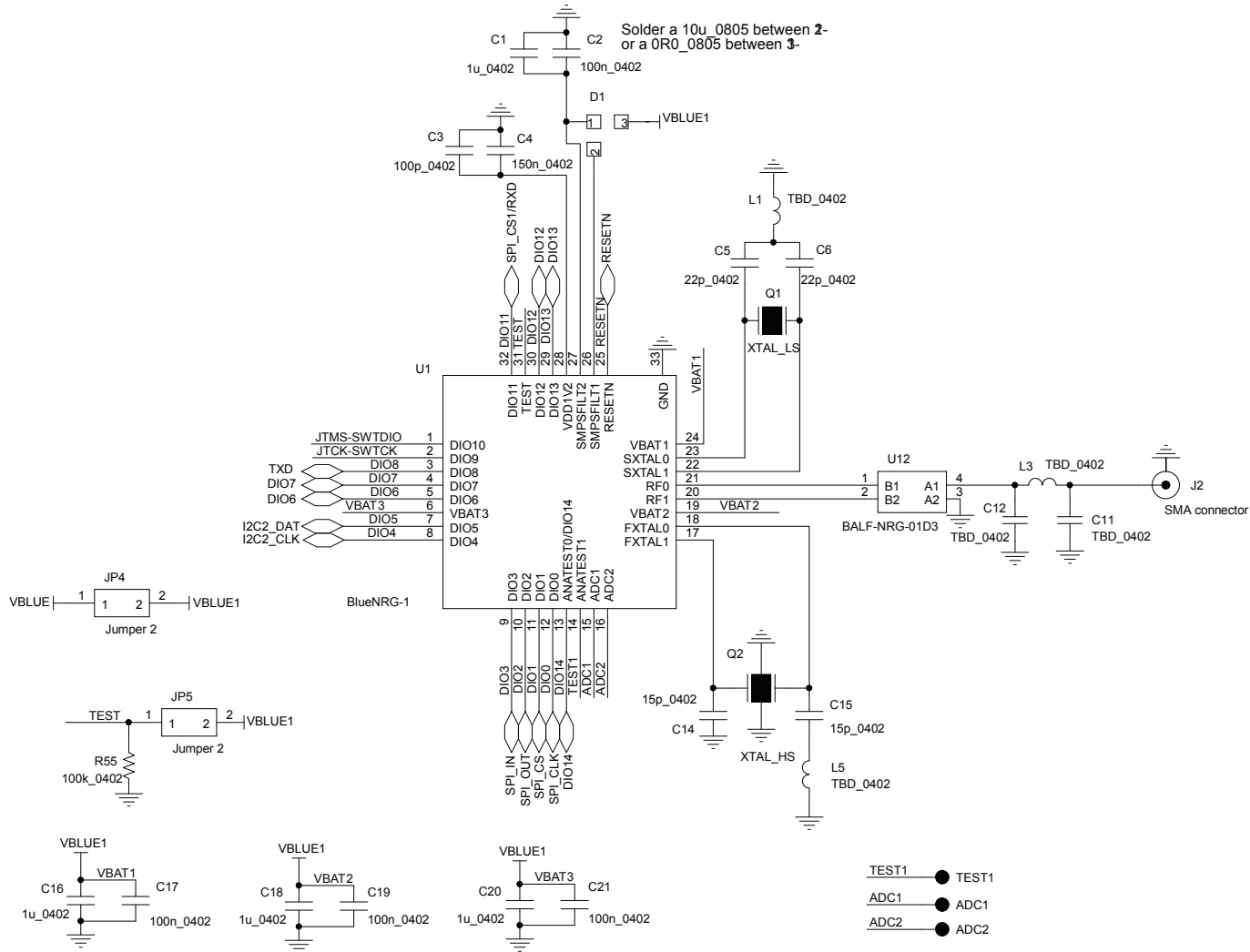

Figure 27. STEVAL-IDB007V1 power management, sensors

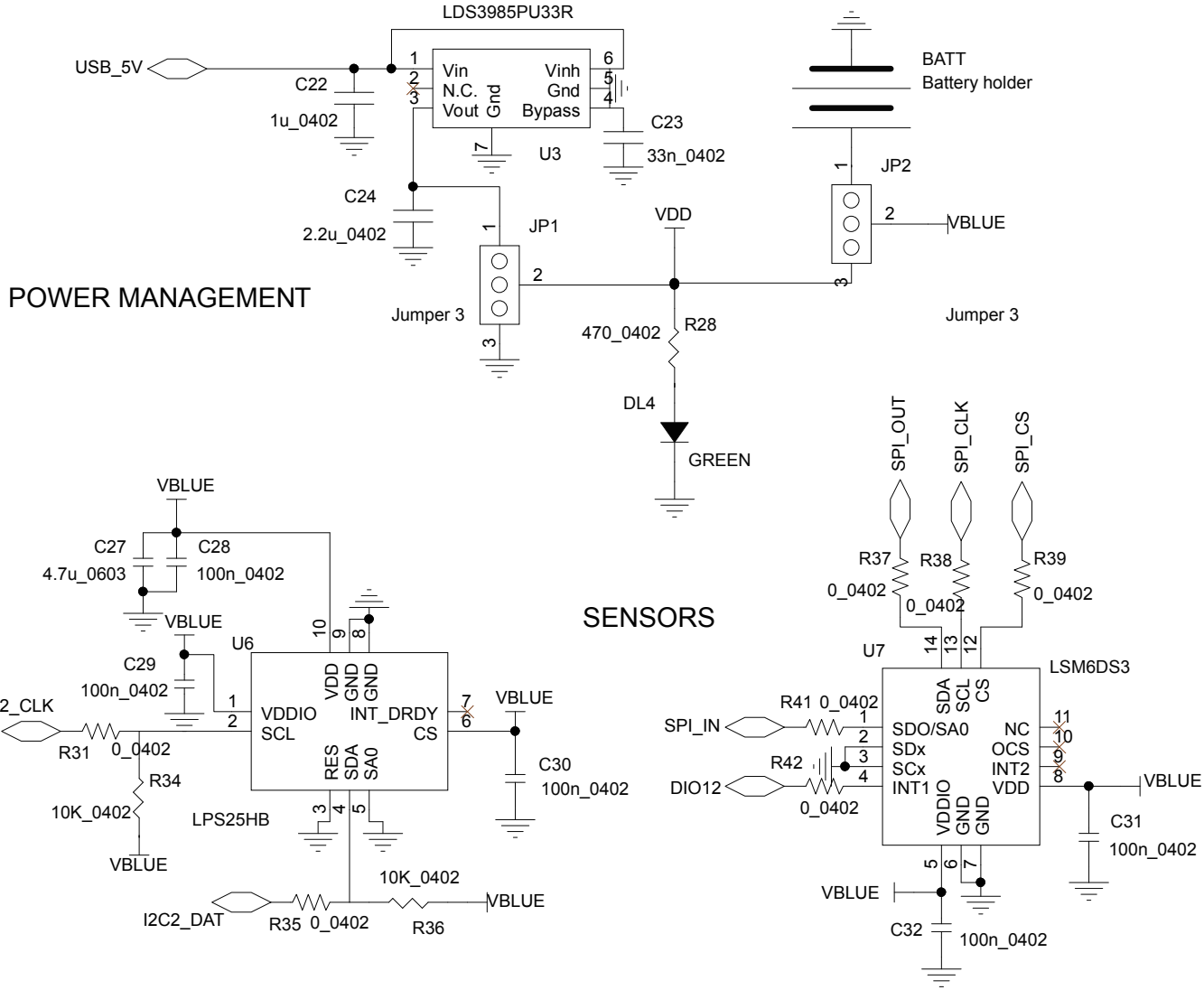

Figure 28. STEVAL-IDB007V1 buttons and LEDs

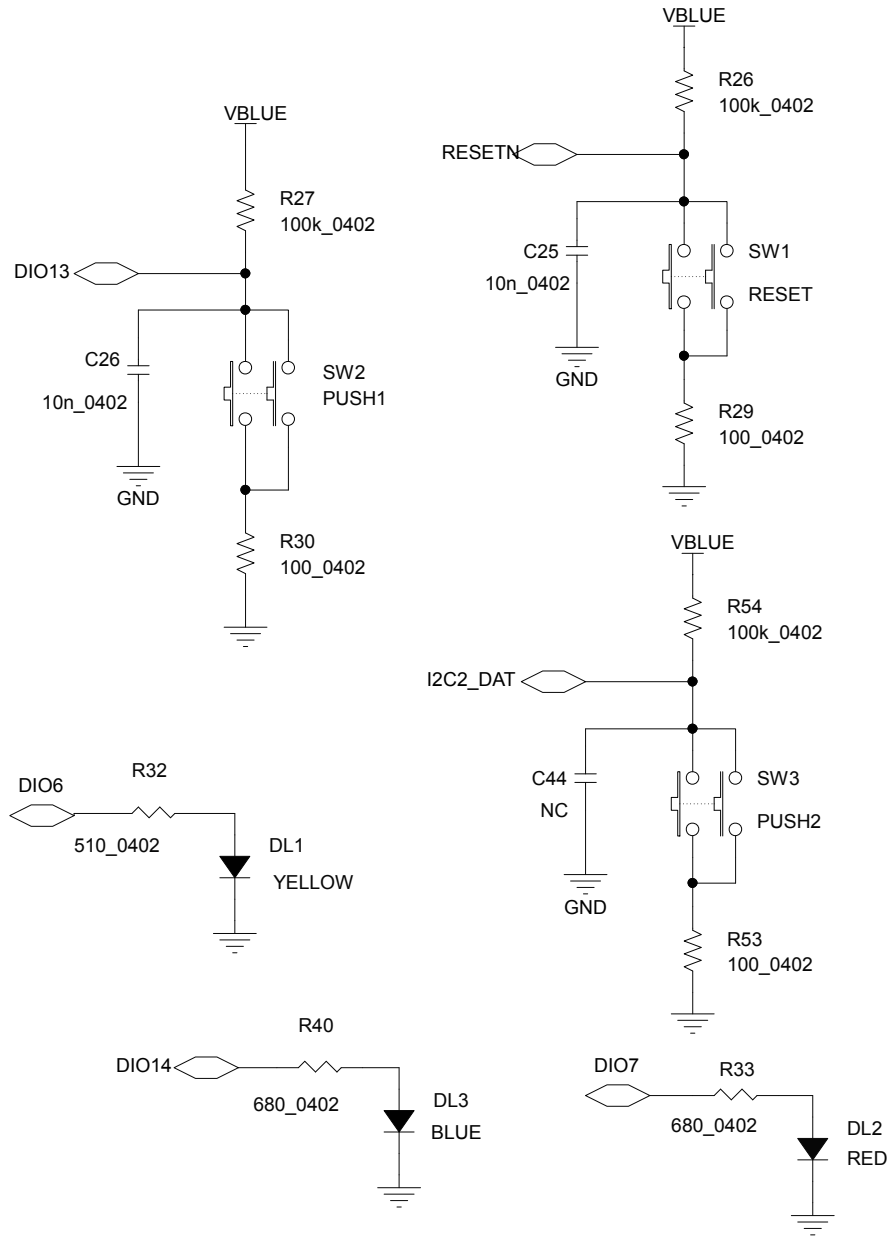

Figure 29. STEVAL-IDB007V1 micro

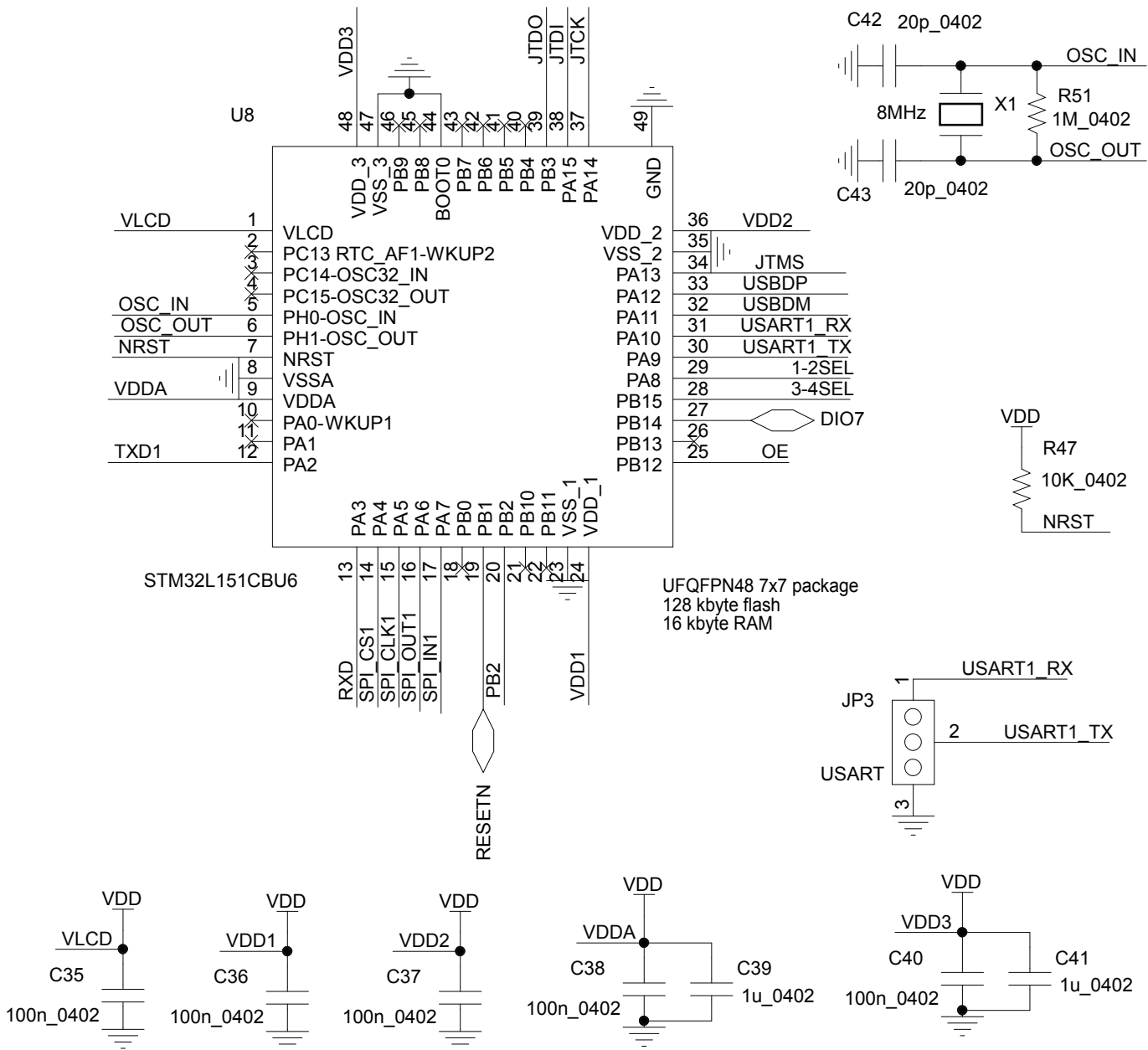
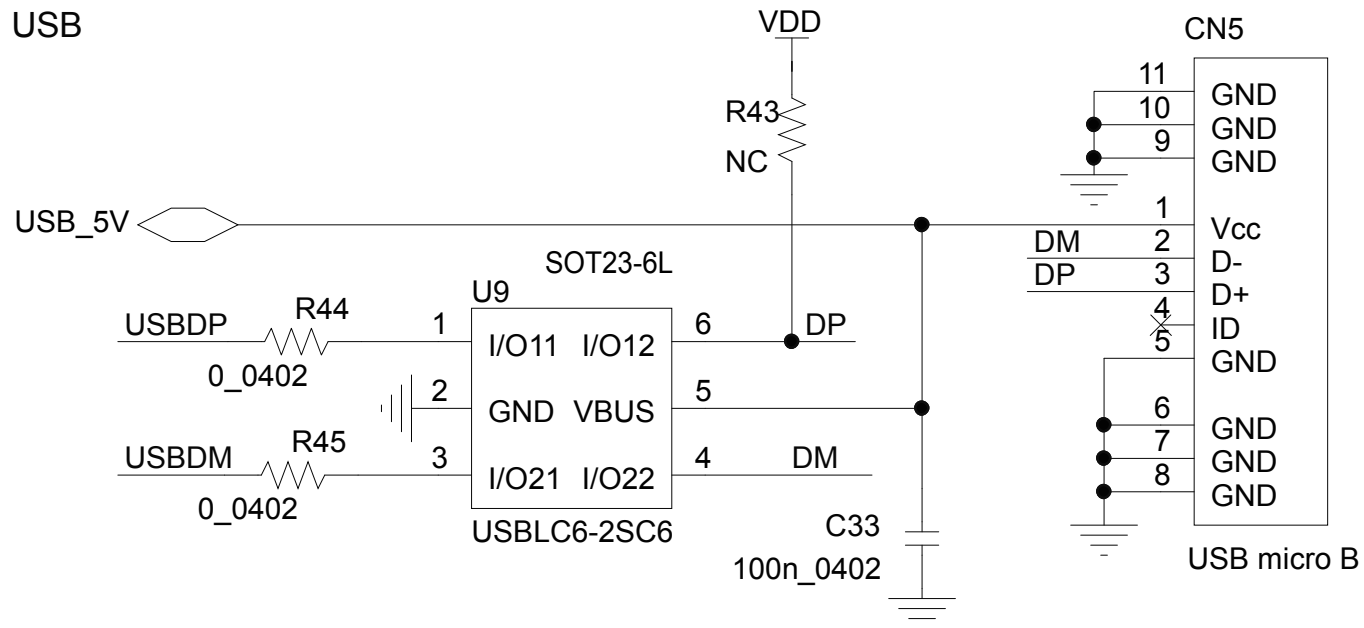
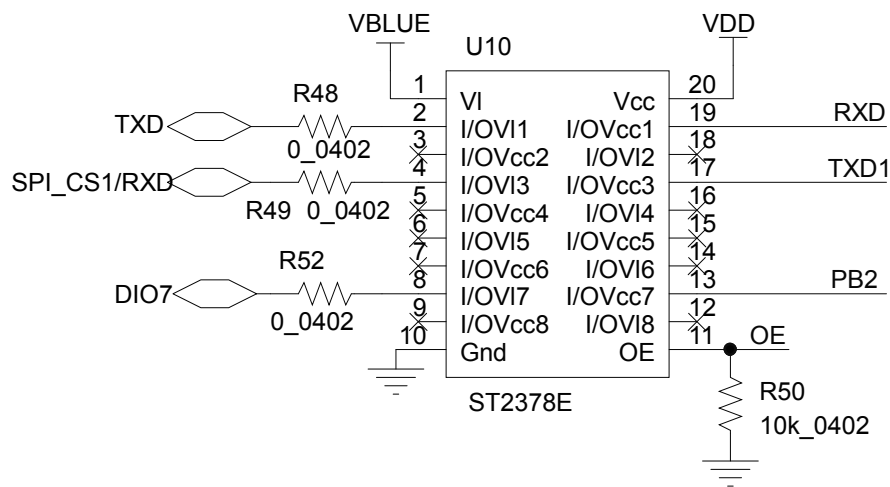

Figure 30. STEVAL-IDB007V1 USB, level translator, JTAG for micro



LEVEL TRANSLATOR



JTAG FOR MICRO

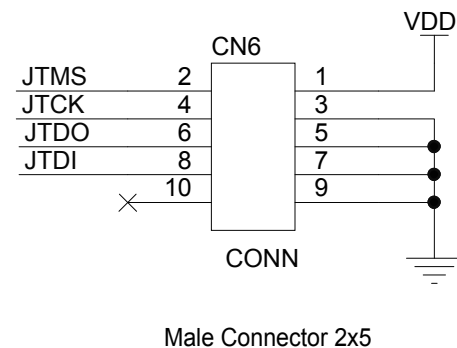
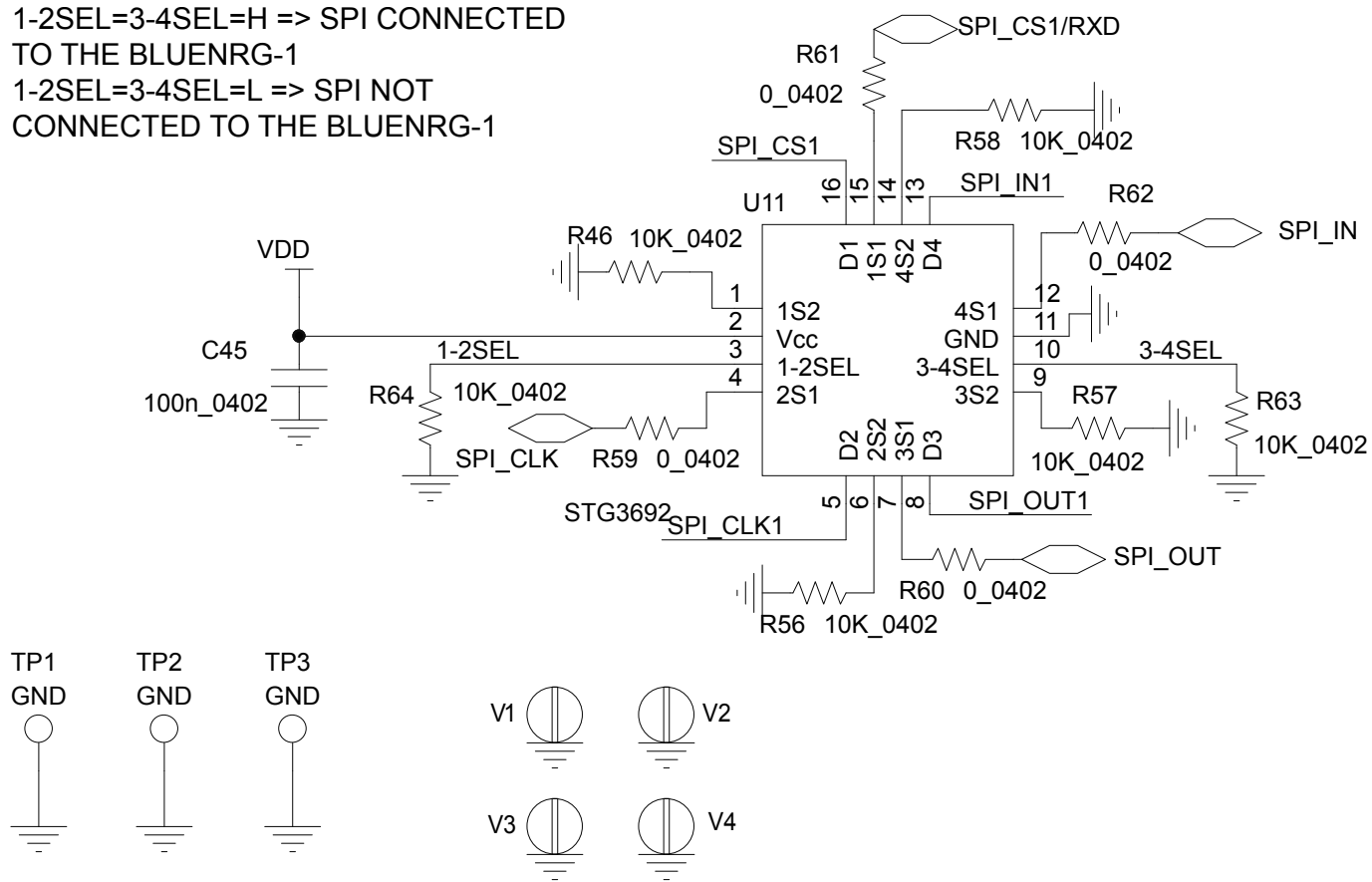

Figure 31. STEVAL-IDB007V1 switch

1-2SEL=3-4SEL=H => SPI CONNECTED
 TO THE BLUENRG-1
 1-2SEL=3-4SEL=L => SPI NOT
 CONNECTED TO THE BLUENRG-1



21.2 STEVAL-IDB007V2 schematic diagrams

Figure 32. STEVAL-IDB007V2 - scheme 1

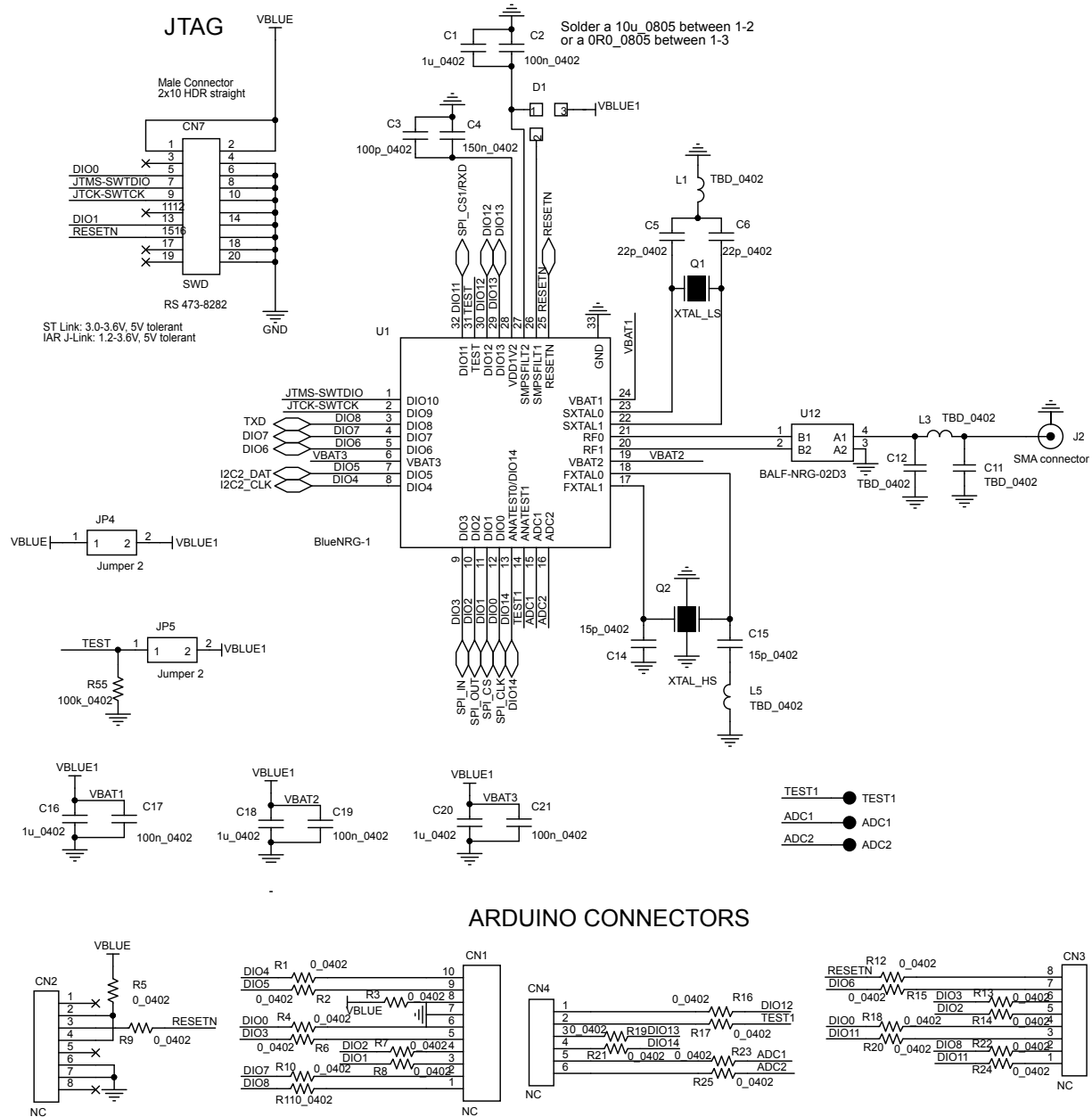
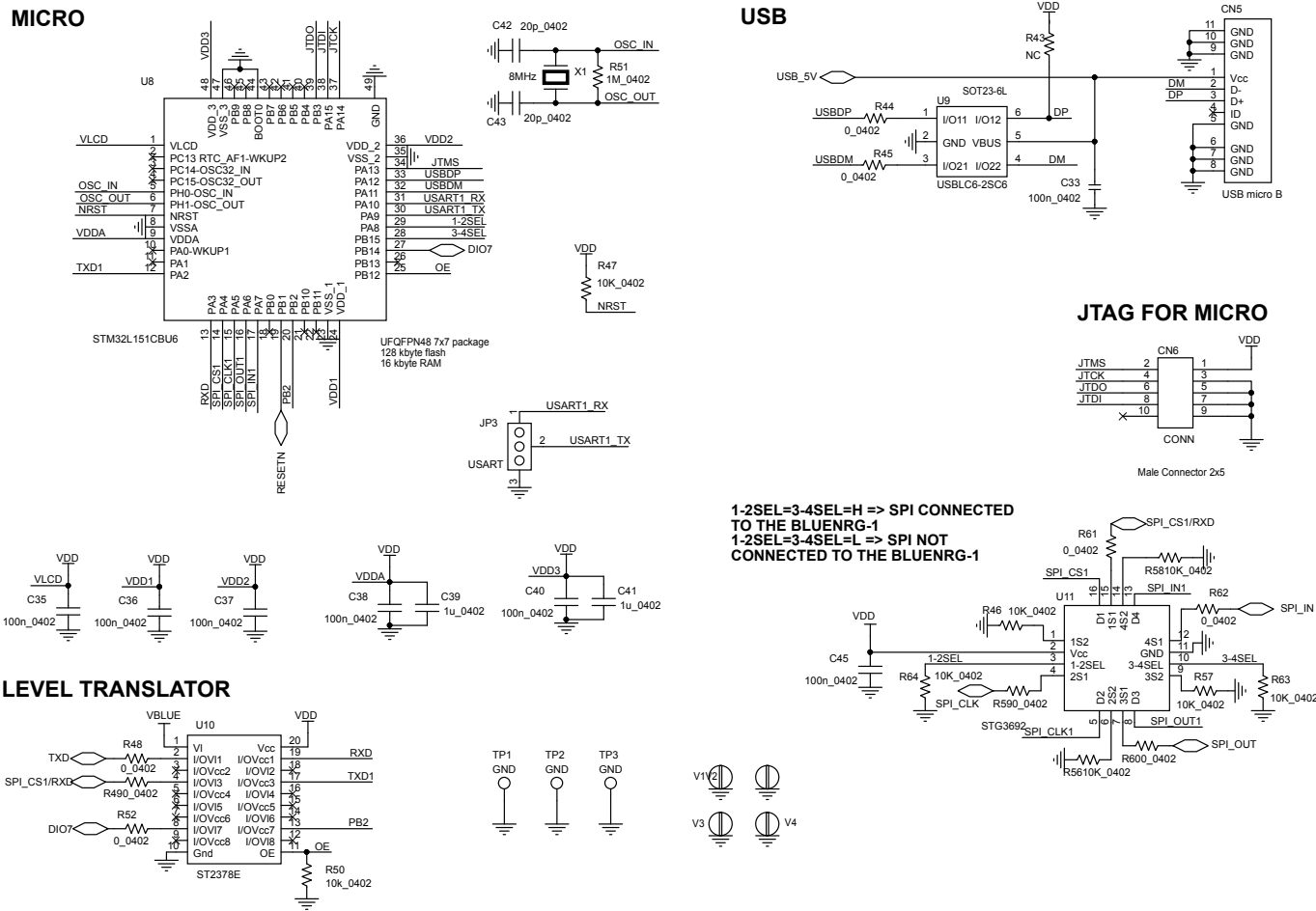

Figure 33. STEVAL-IDB007V2 - scheme 2



1-2SEL=3-4SEL=H => SPI CONNECTED TO THE BLUENRG-1
 1-2SEL=3-4SEL=L => SPI NOT CONNECTED TO THE BLUENRG-1



Figure 34. STEVAL-IDB007V2 - scheme 3

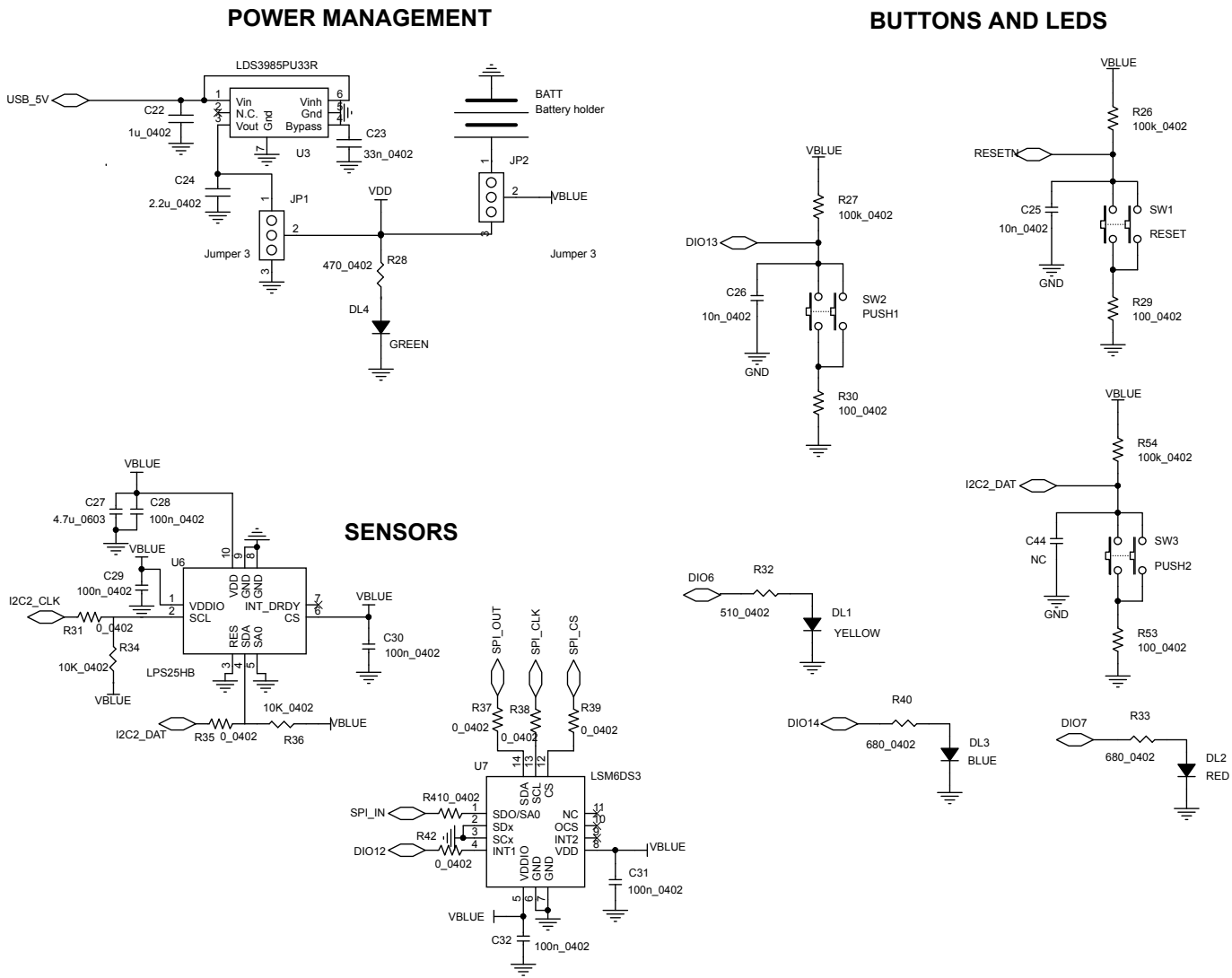

21.3 STEVAL-IDB008V1 schematic digrams

Figure 35. STEVAL-IDB008V1 circuit schematic - JTAG

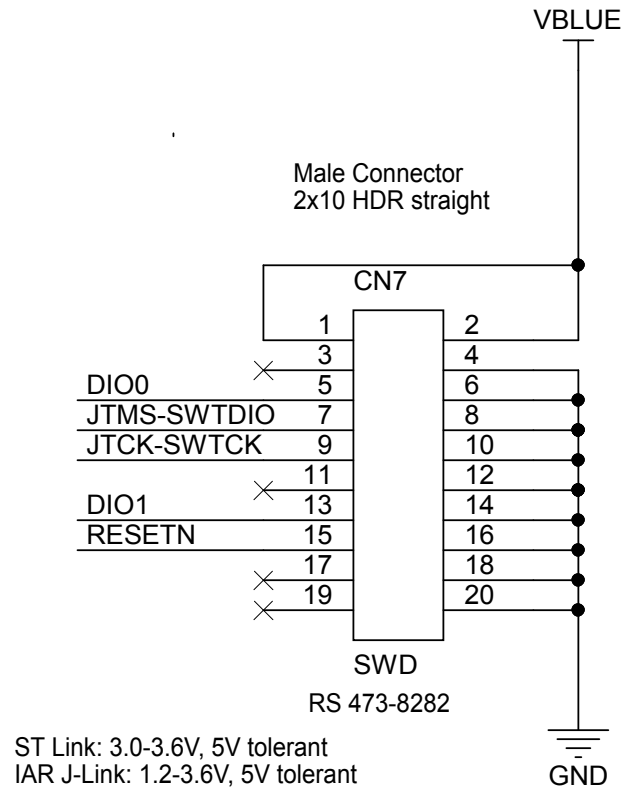

Figure 36. STEVAL-IDB008V1 circuit schematic - Arduino connectors

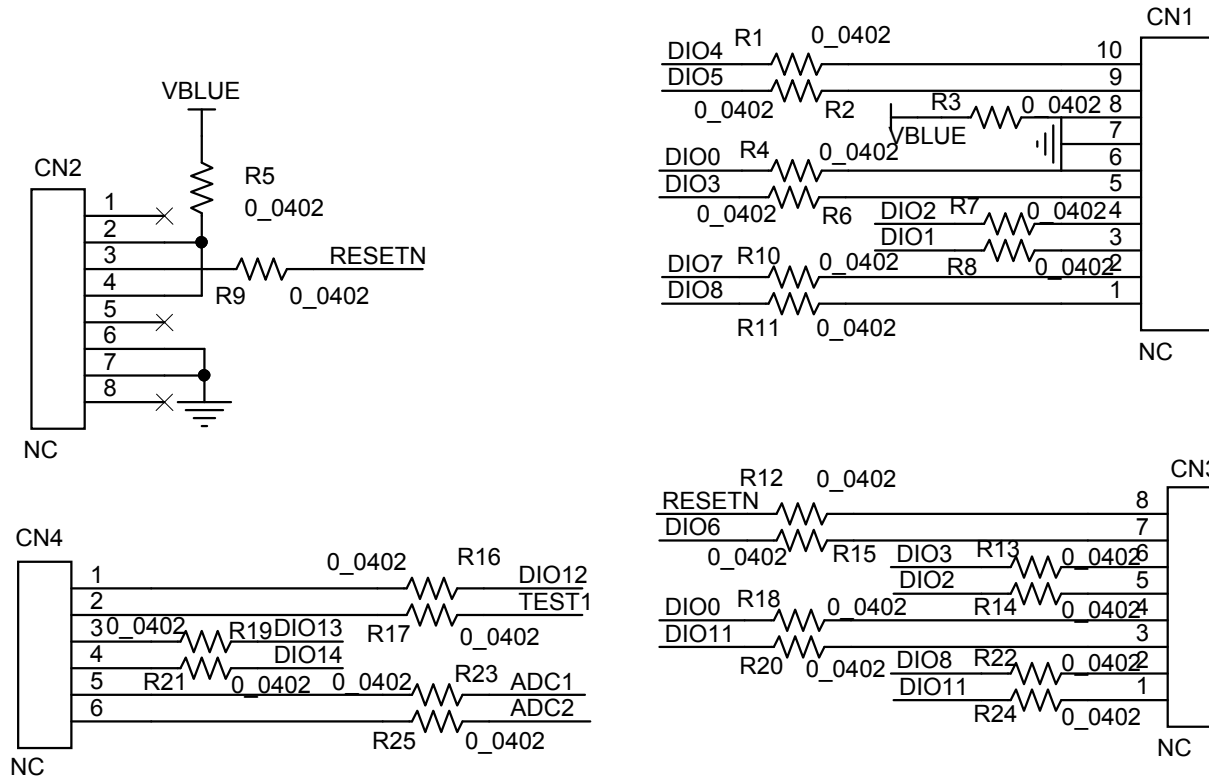

Figure 37. STEVAL-IDB008V1 circuit schematic - BlueNRG-2

Solder a 10u_0805 between 1-2
or a 0R0_0805 between 1-3

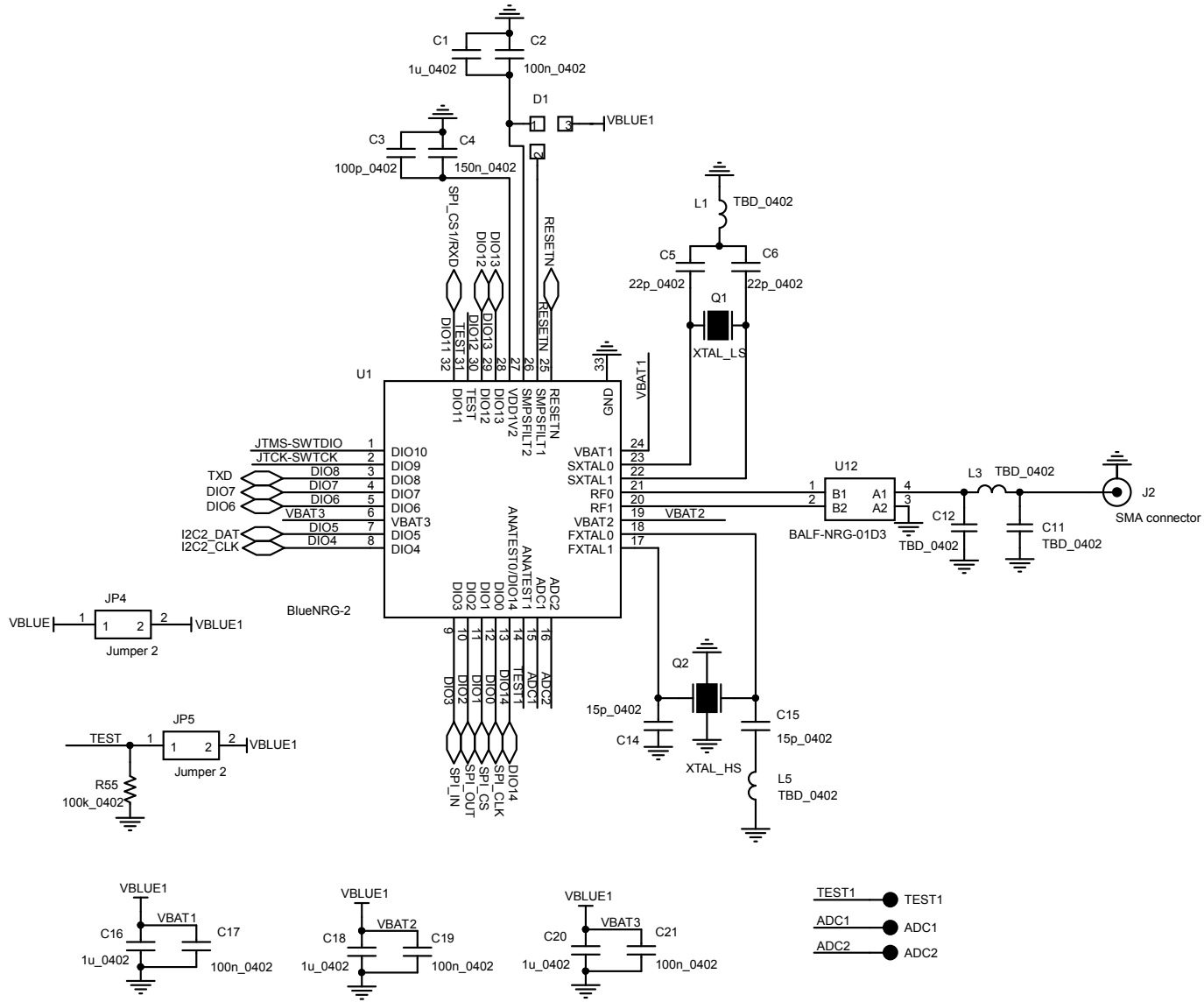

Figure 38. STEVAL-IDB008V1 circuit schematic - buttons and LEDs

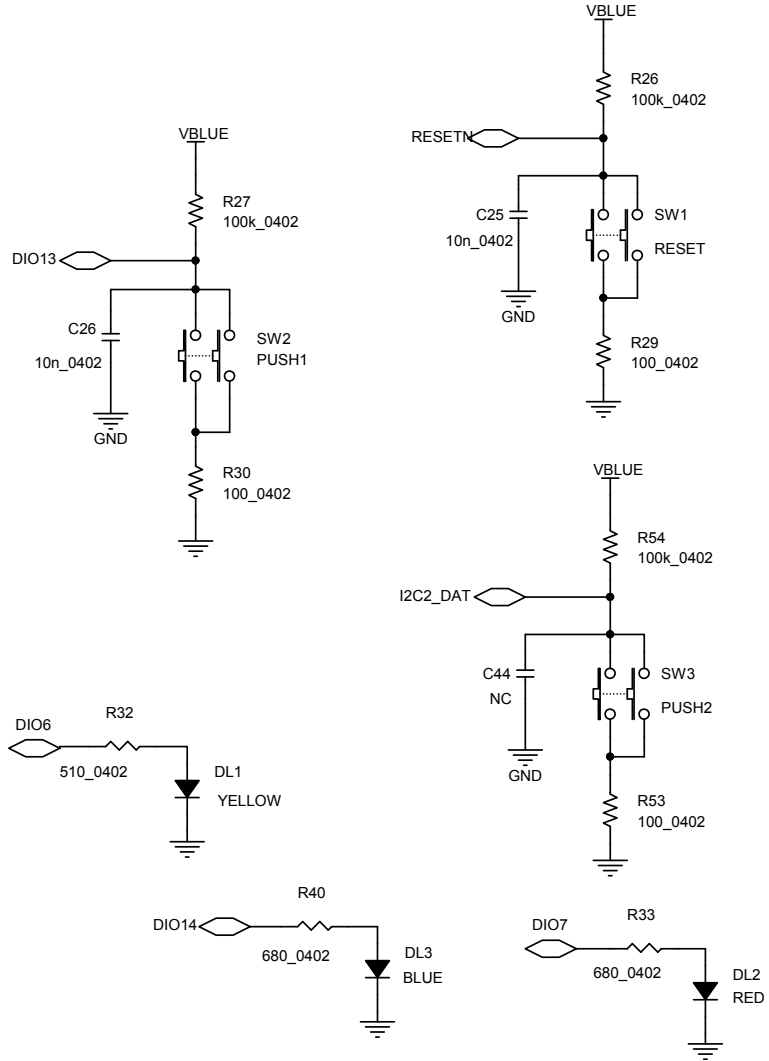

Figure 39. STEVAL-IDB008V1 circuit schematic - sensors

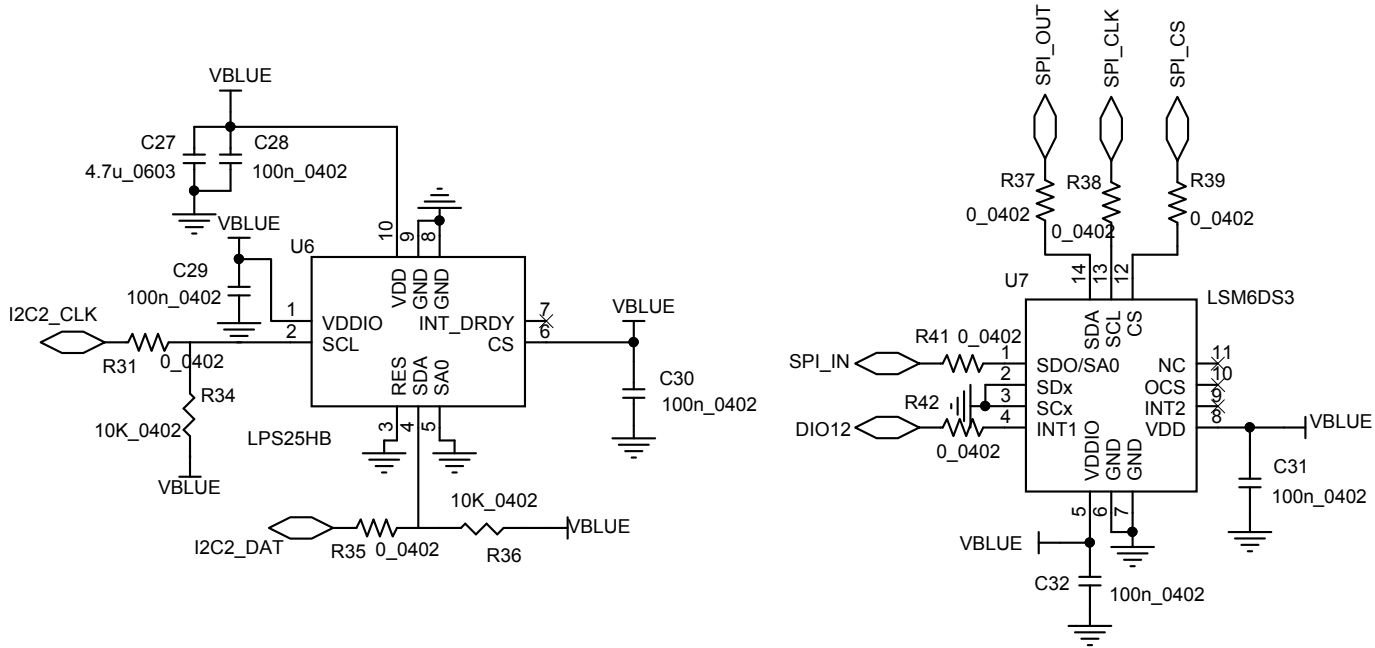

Figure 40. STEVAL-IDB008V1 circuit schematic - power management

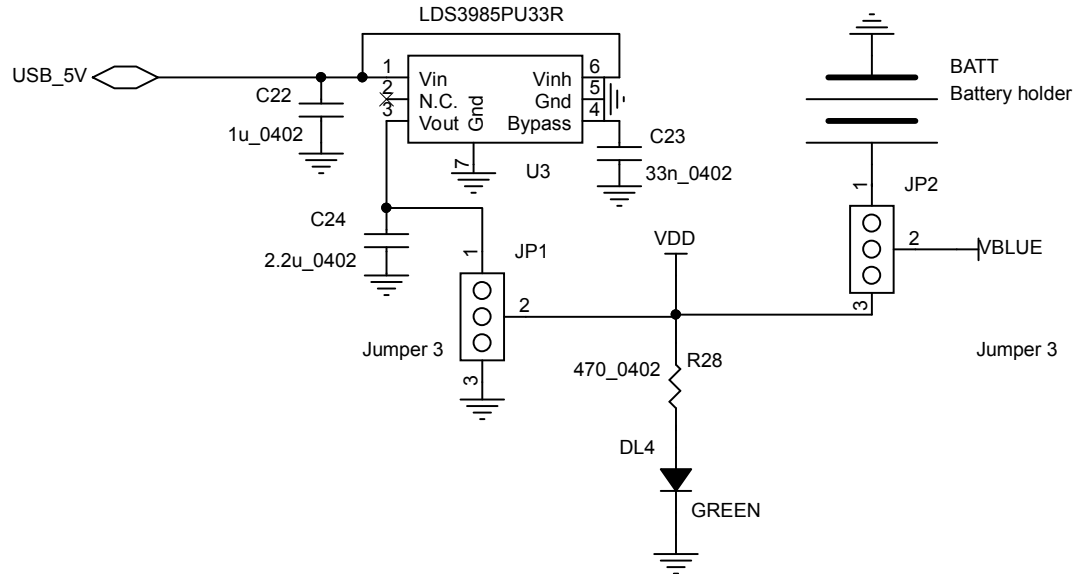

Figure 41. STEVAL-IDB008V1 circuit schematic - JTAG for MCU

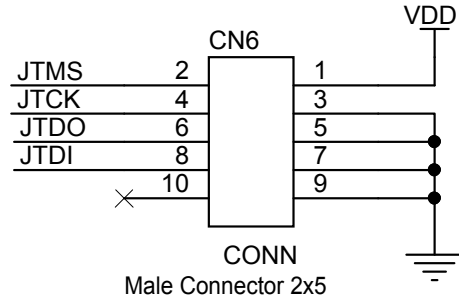

Figure 42. STEVAL-IDB008V1 circuit schematic - USB

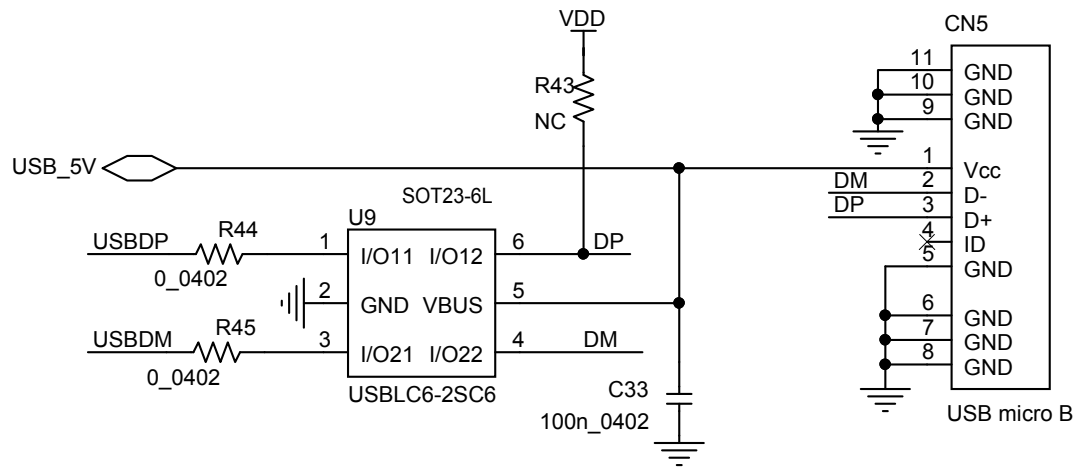

Figure 43. STEVAL-IDB008V1 circuit schematic - test points

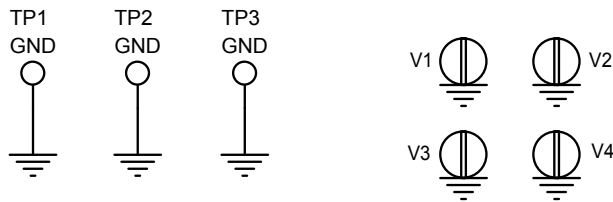

Figure 44. STEVAL-IDB008V1 circuit schematic - switch

1-2SEL=3-4SEL=H => SPI CONNECTED
TO THE BLUENRG-2
1-2SEL=3-4SEL=L => SPI NOT
CONNECTED TO THE BLUENRG-2

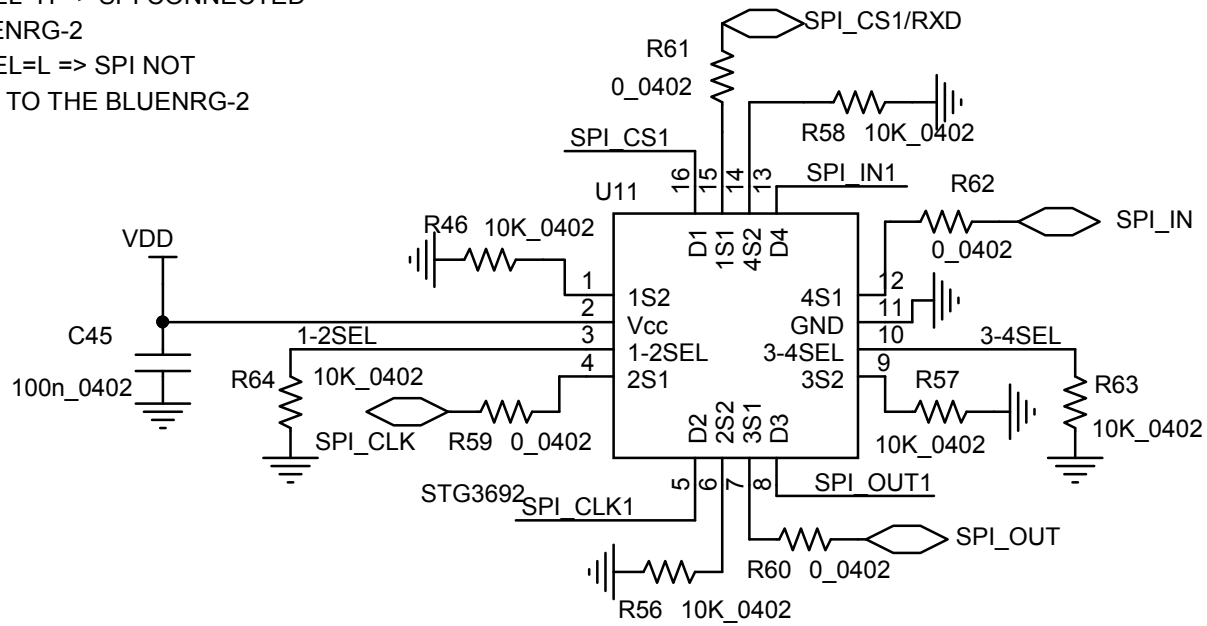

Figure 45. STEVAL-IDB008V1 circuit schematic - microcontroller

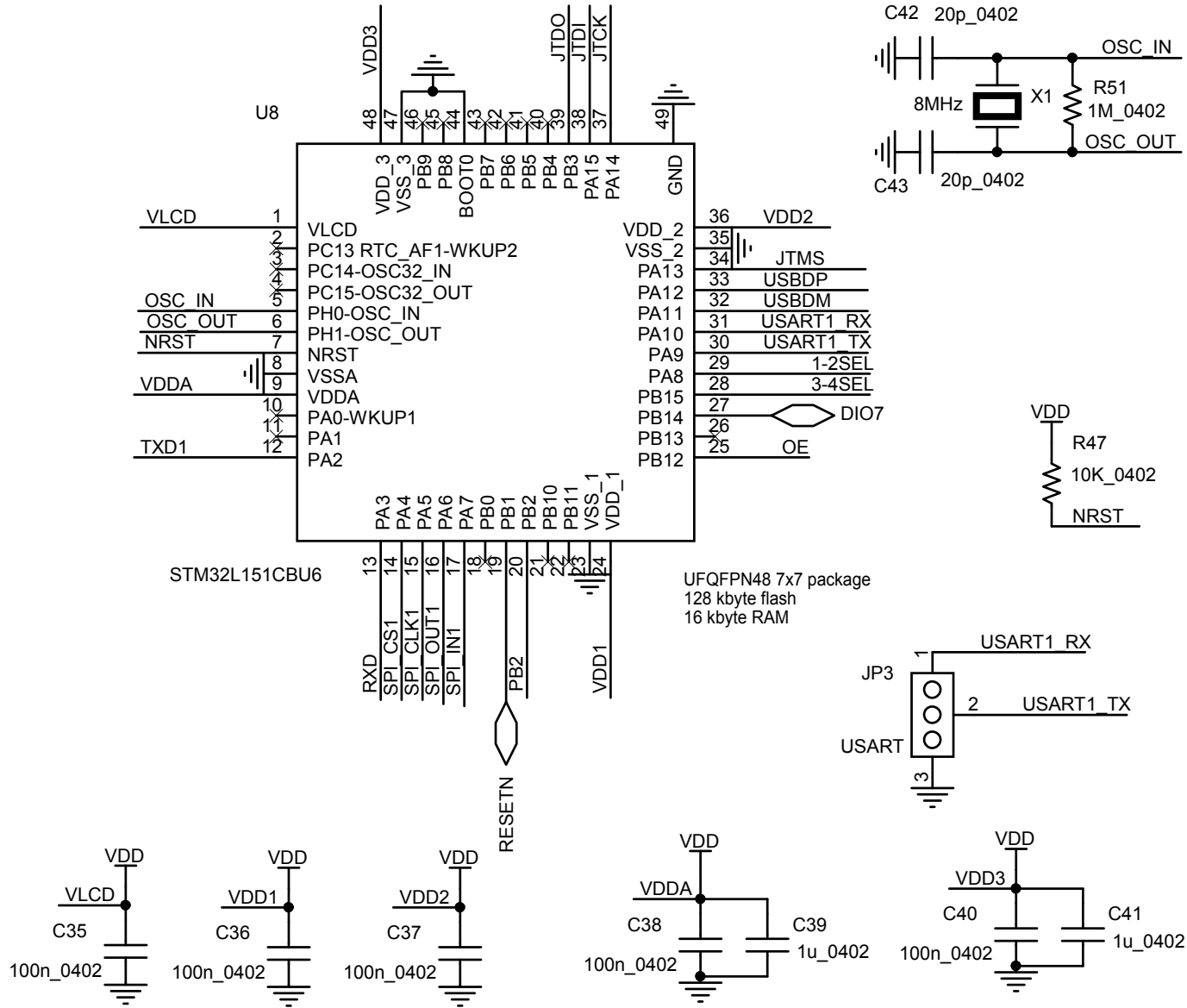
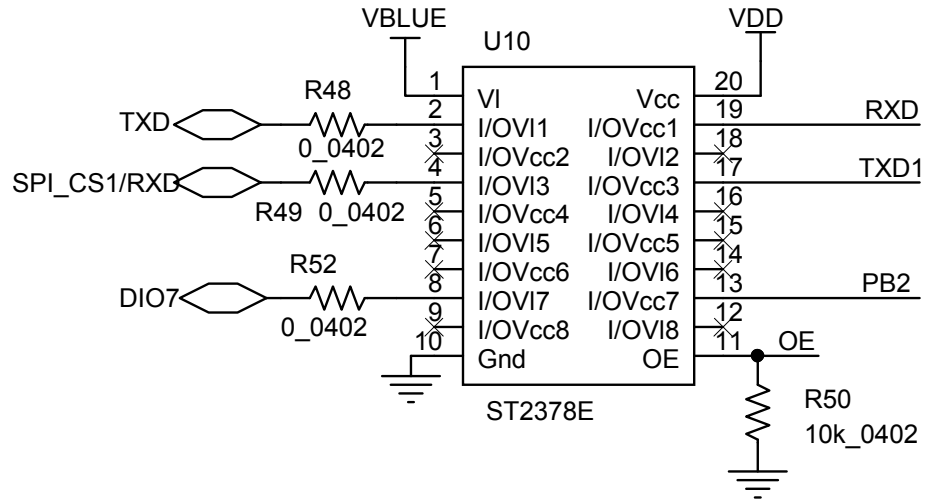

Figure 46. STEVAL-IDB008V1 circuit schematic - level translator



21.4 STEVAL-IDB008V2 schematic digrams

Figure 47. STEVAL-IDB008V2 - JTAG

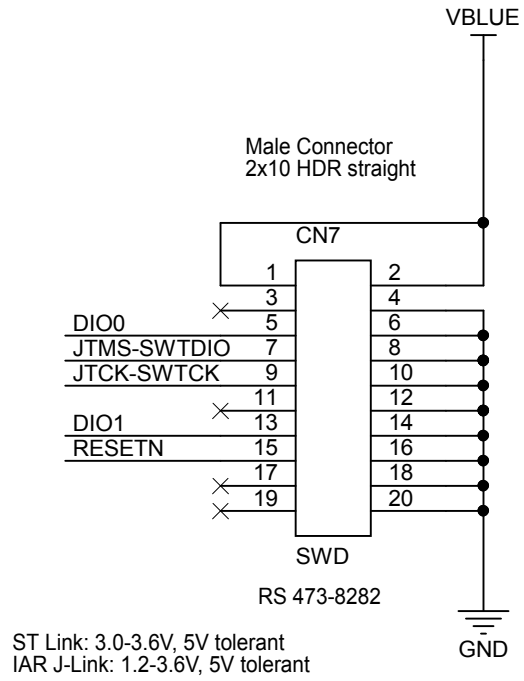

Figure 48. STEVAL-IDB008V2 - Arduino connection

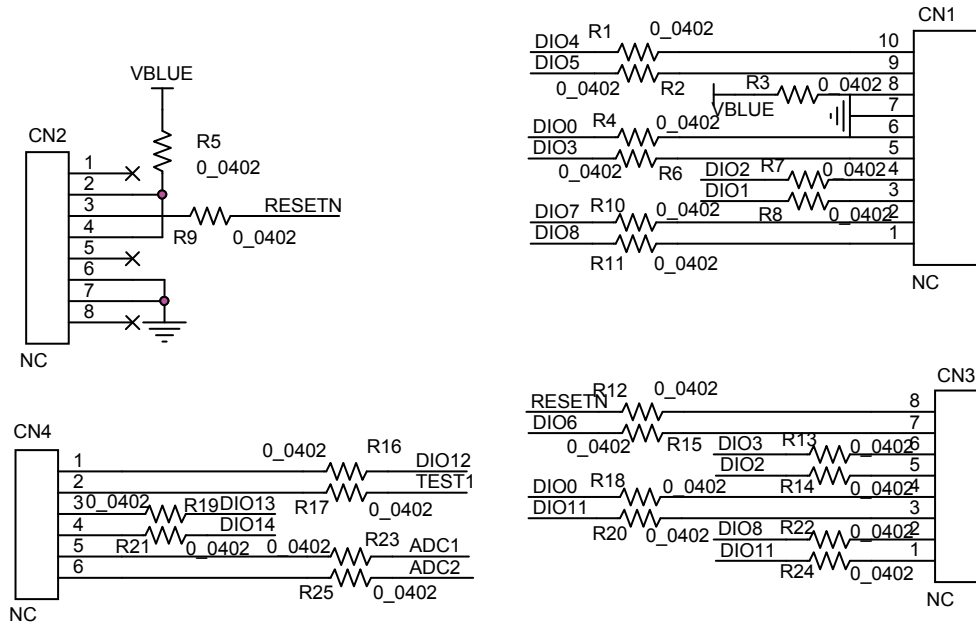

Figure 49. STEVAL-IDB008V2 circuit schematic

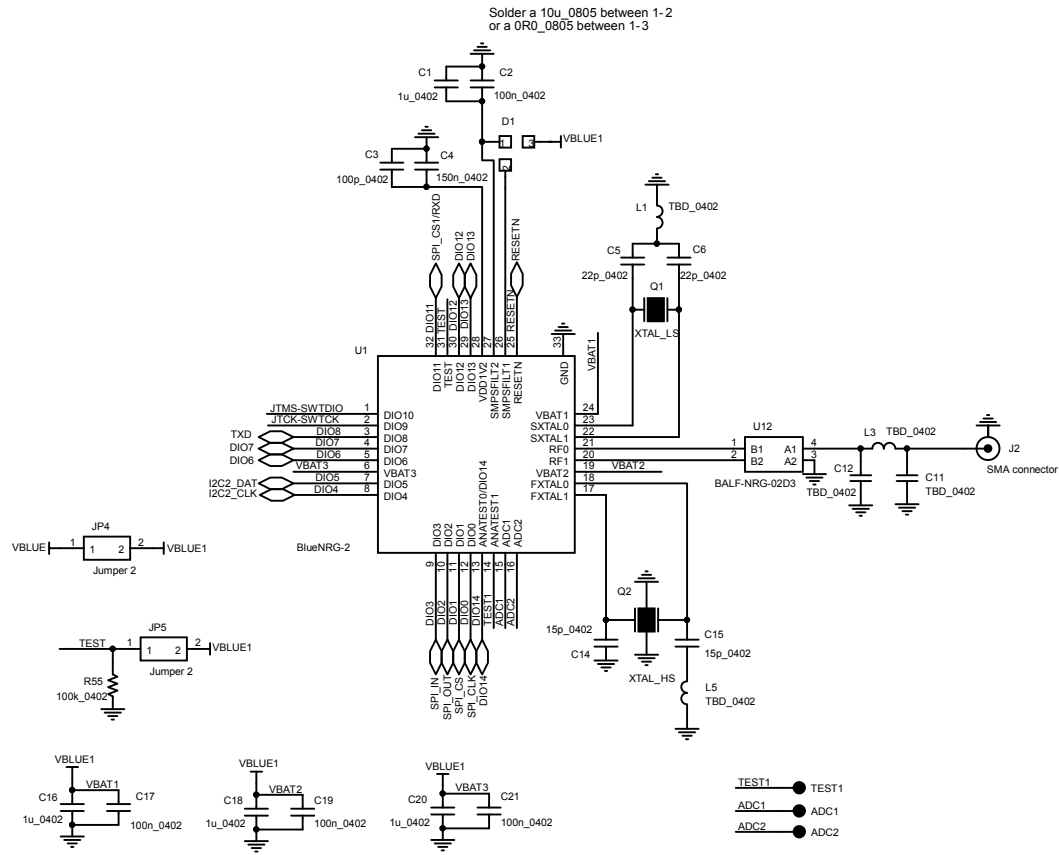

Figure 50. STEVAL-IDB008V2 - power managements

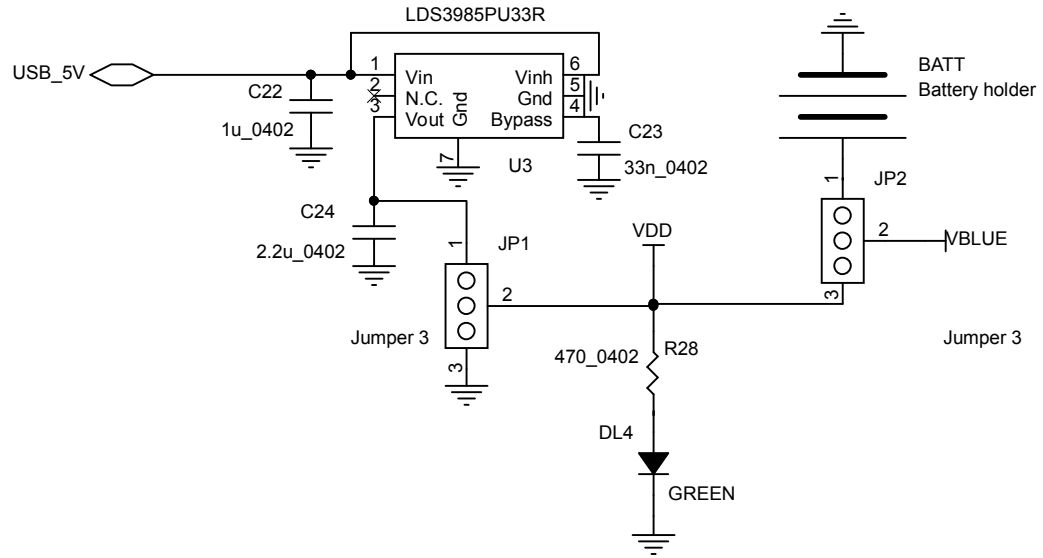

Figure 51. STEVAL-IDB008V2 - SENSORS

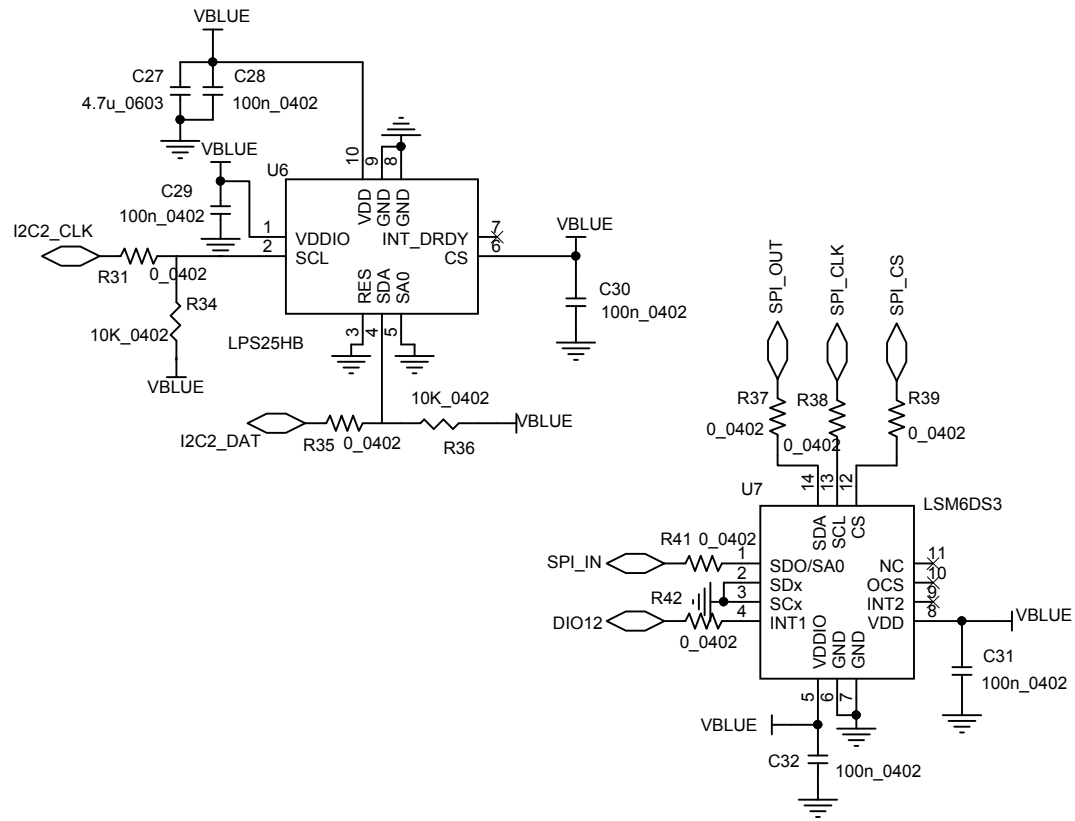

Figure 52. STEVAL-IDB008V2 - buttons and leds

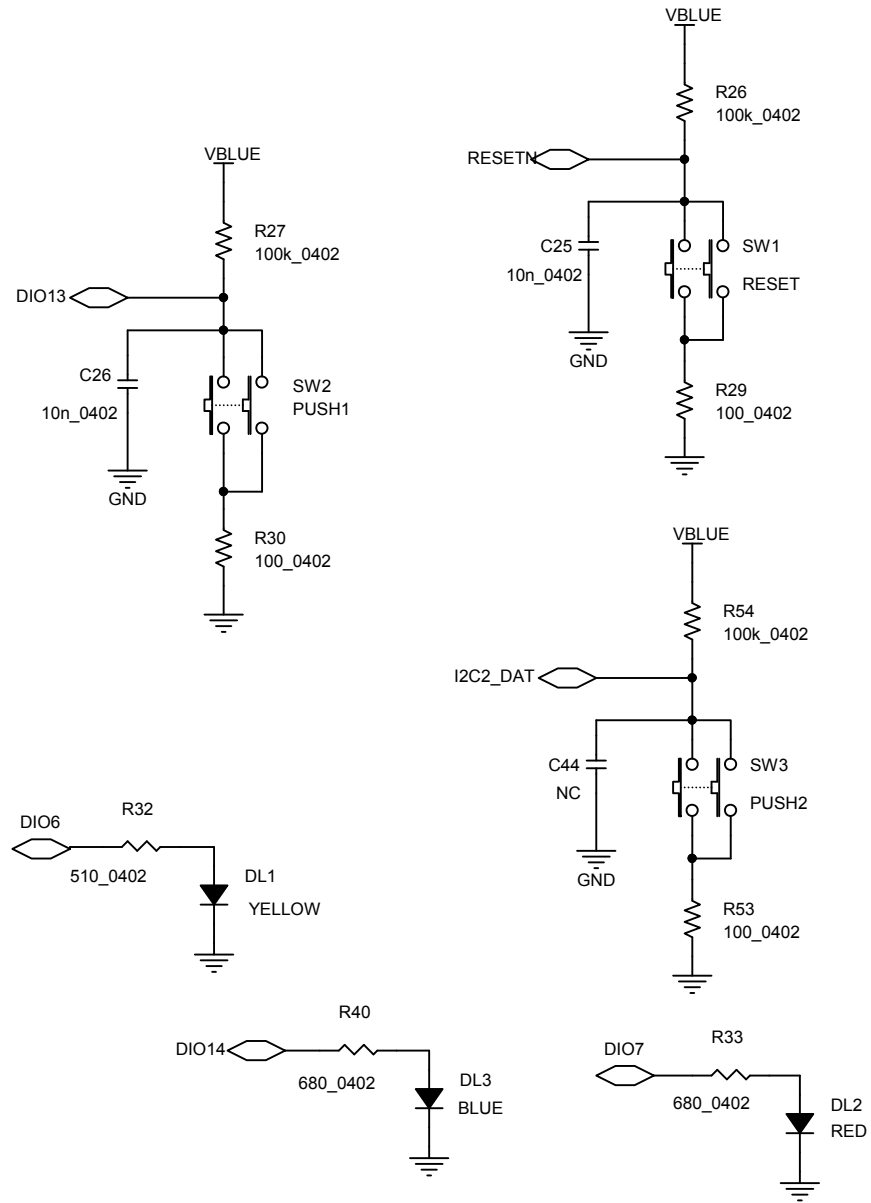

Figure 53. STEVAL-IDB008V2 - micro

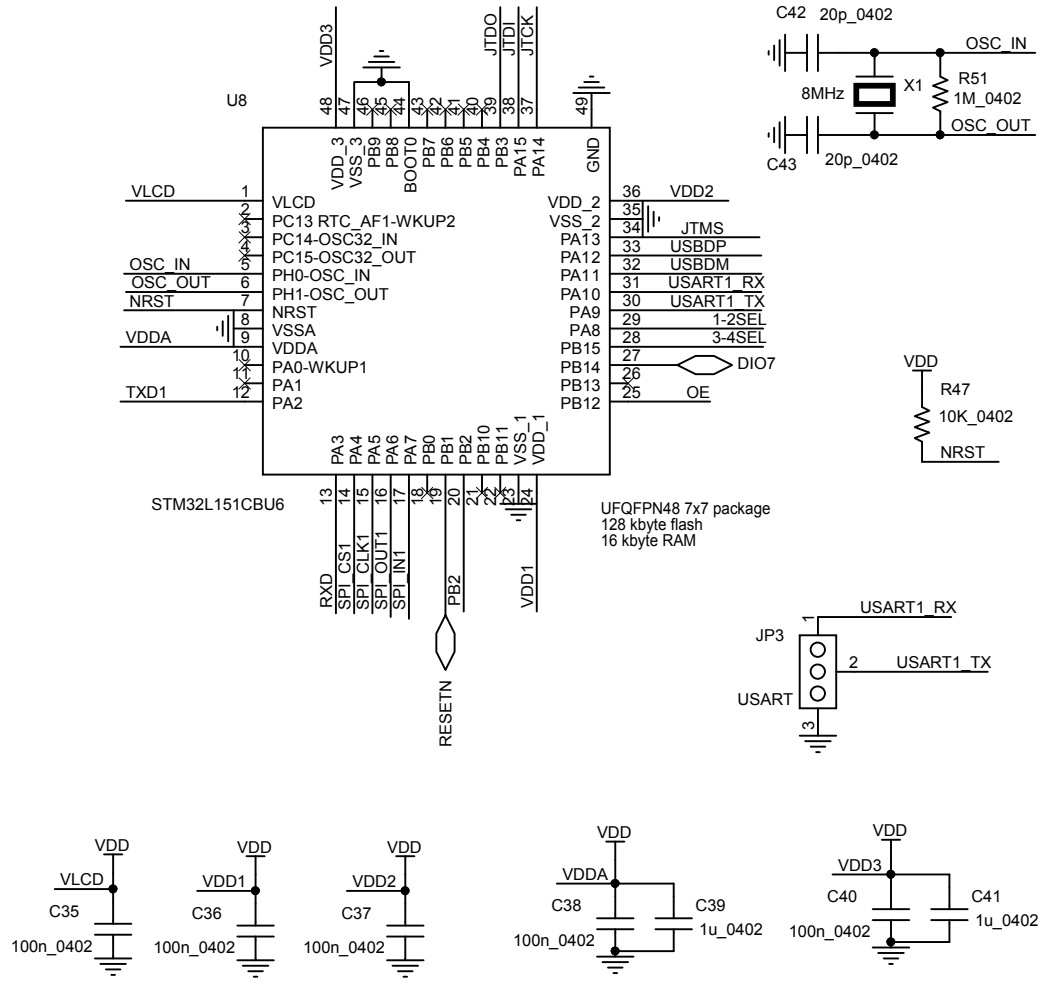

Figure 54. STEVAL-IDB008V2 - USB

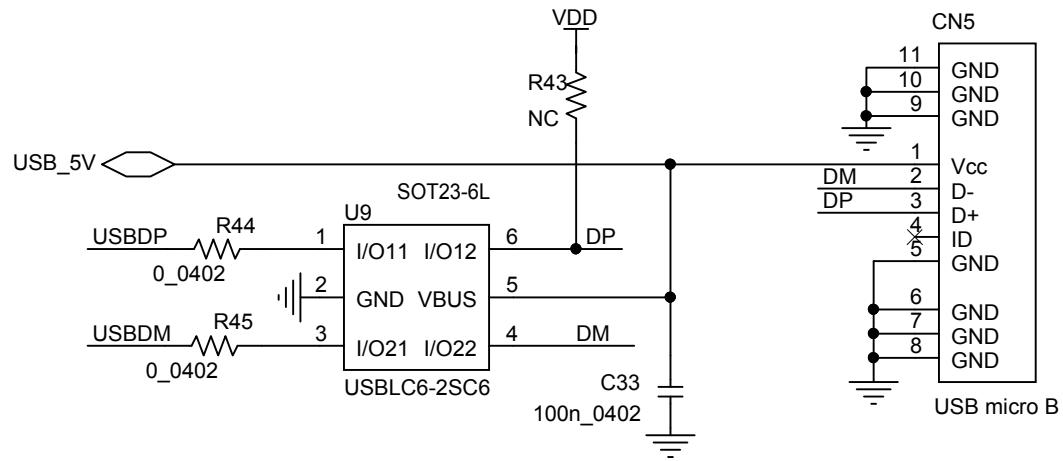

Figure 55. STEVAL-IDB008V2 - JTAG for micro

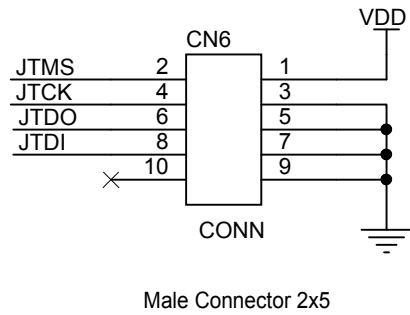

Figure 56. STEVAL-IDB008V2 - level translator

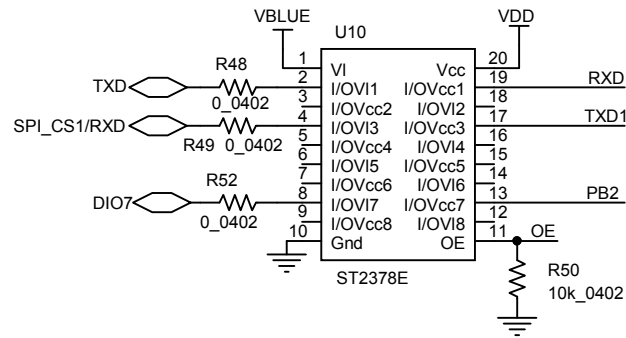
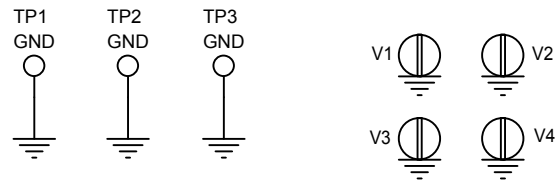
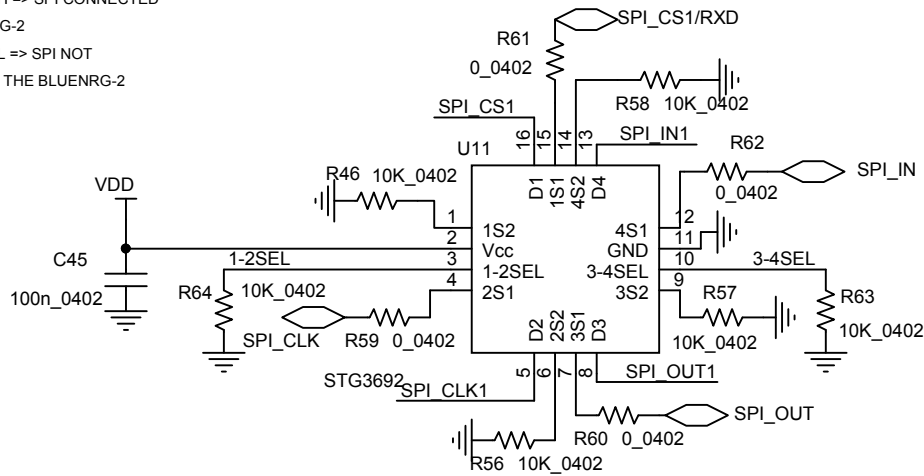

Figure 57. STEVAL-IDB008V2 - Switch

1-2SEL=3-4SEL=H => SPI CONNECTED
TO THE BLUENRG-2
1-2SEL=3-4SEL=L => SPI NOT
CONNECTED TO THE BLUENRG-2



21.5 STEVAL-IBD008V1M schematic diagrams

Figure 58. STEVAL-IBD008V1M circuit schematic (1 of 3)

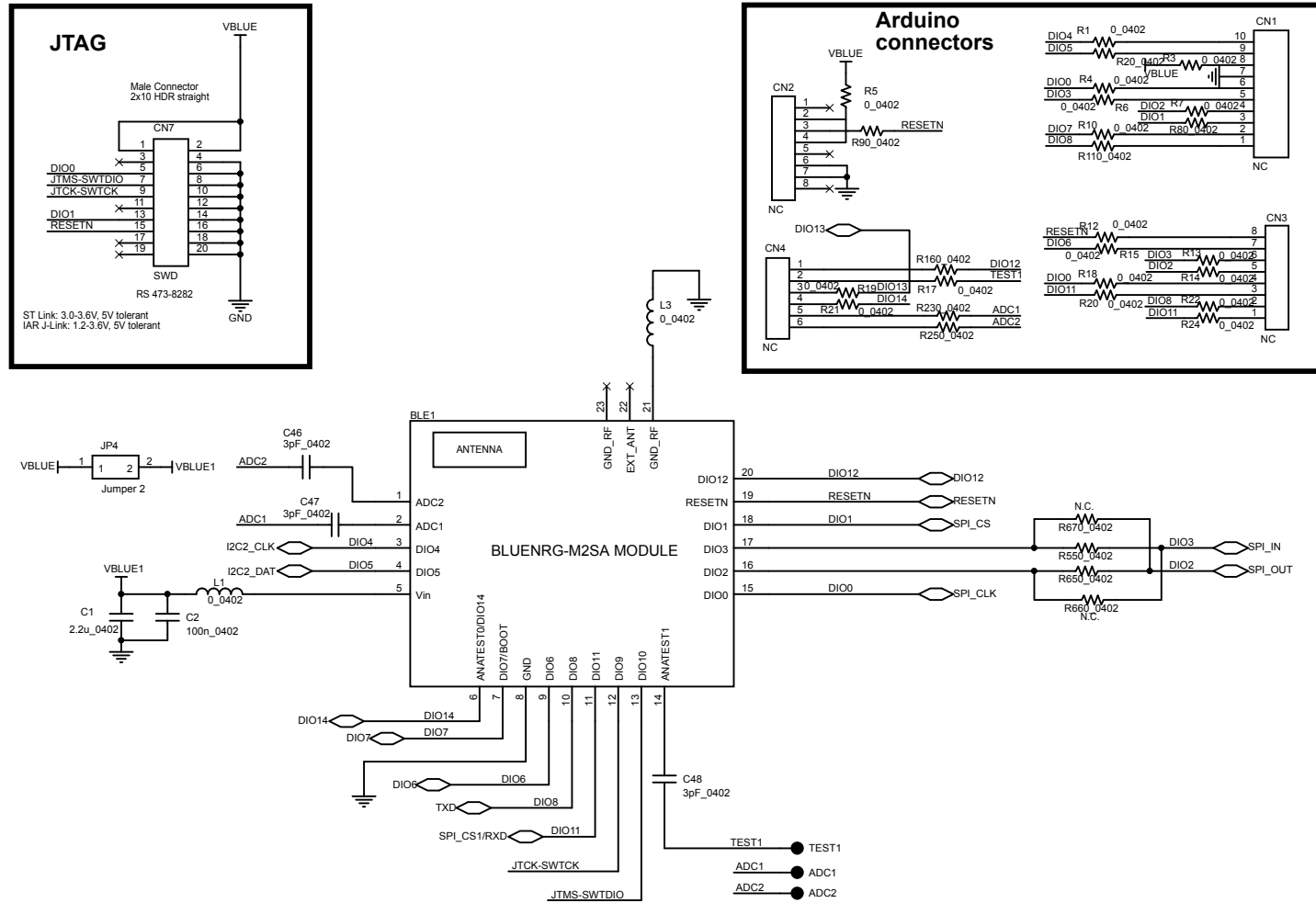

Figure 59. STEVAL-IBD008V1M circuit schematic (2 of 3)

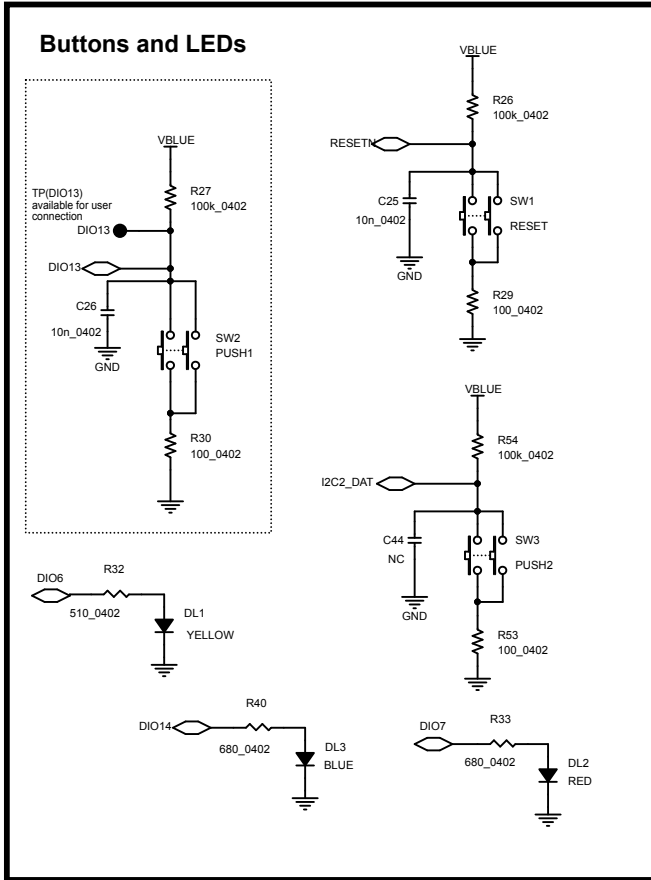
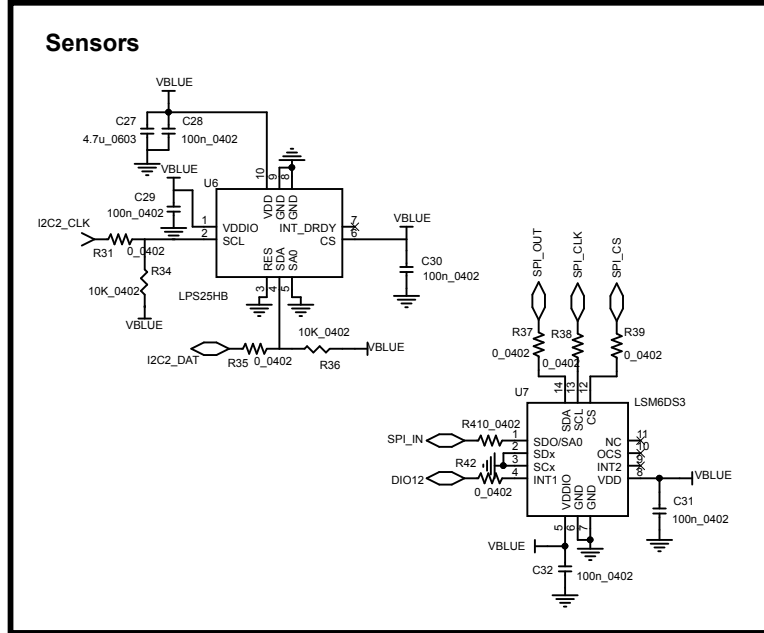
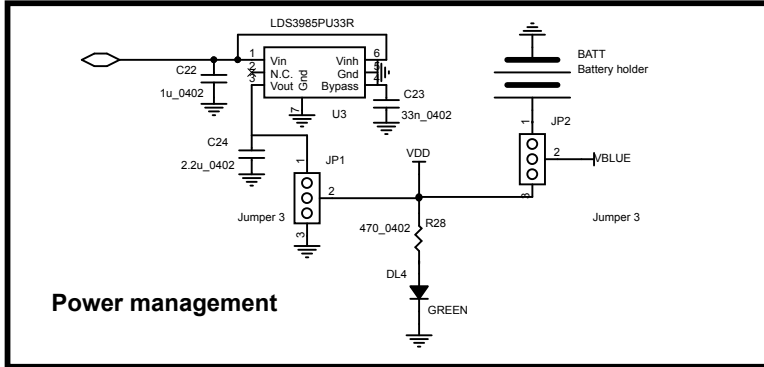
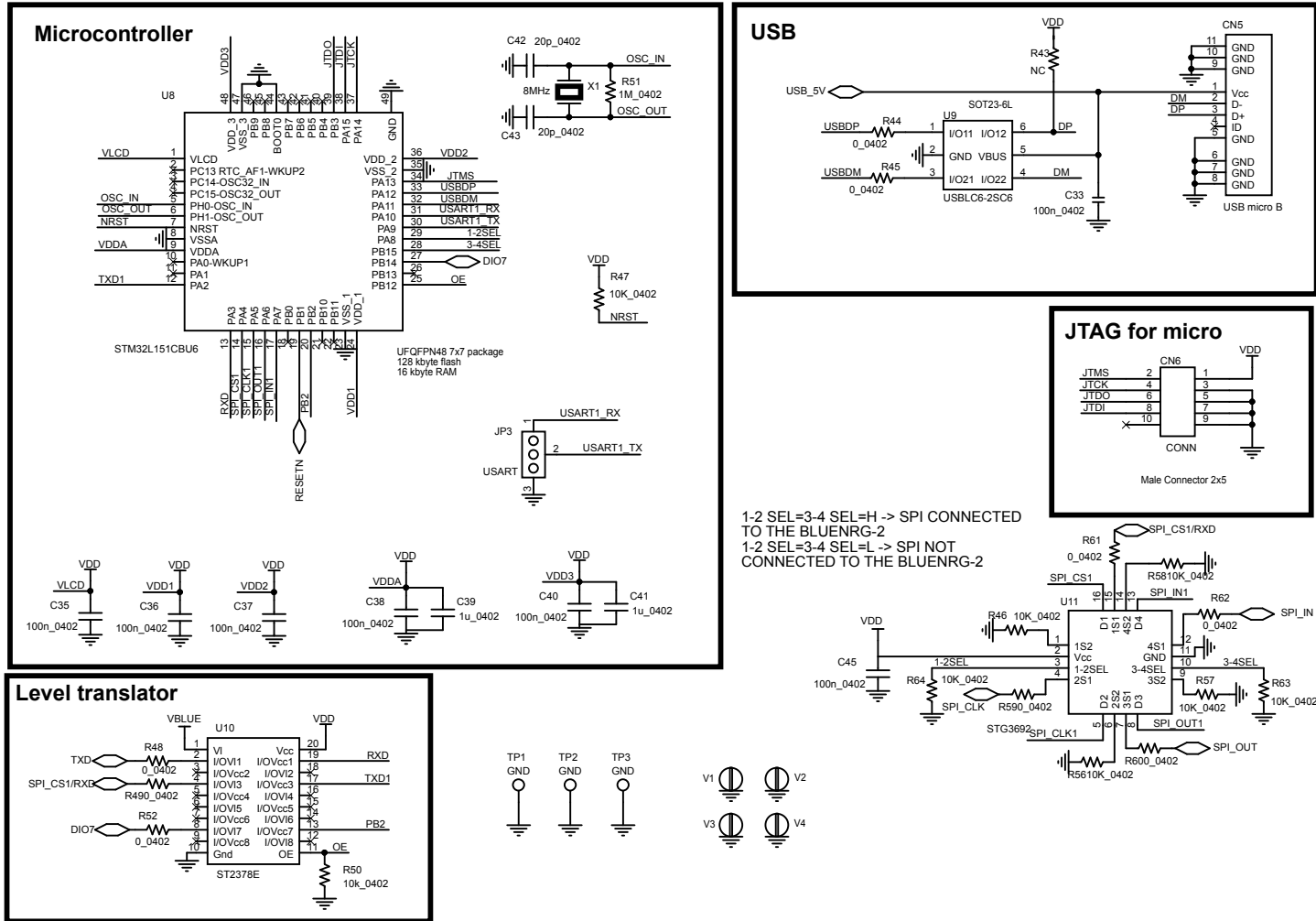

Figure 60. STEVAL-IBD008V1M circuit schematic (3 of 3)



1-2 SEL=3-4 SEL=H -> SPI CONNECTED TO THE BLUENRG-2
 1-2 SEL=3-4 SEL=L -> SPI NOT CONNECTED TO THE BLUENRG-2



Figure 61. STEVAL-IDB009V1 board schematic

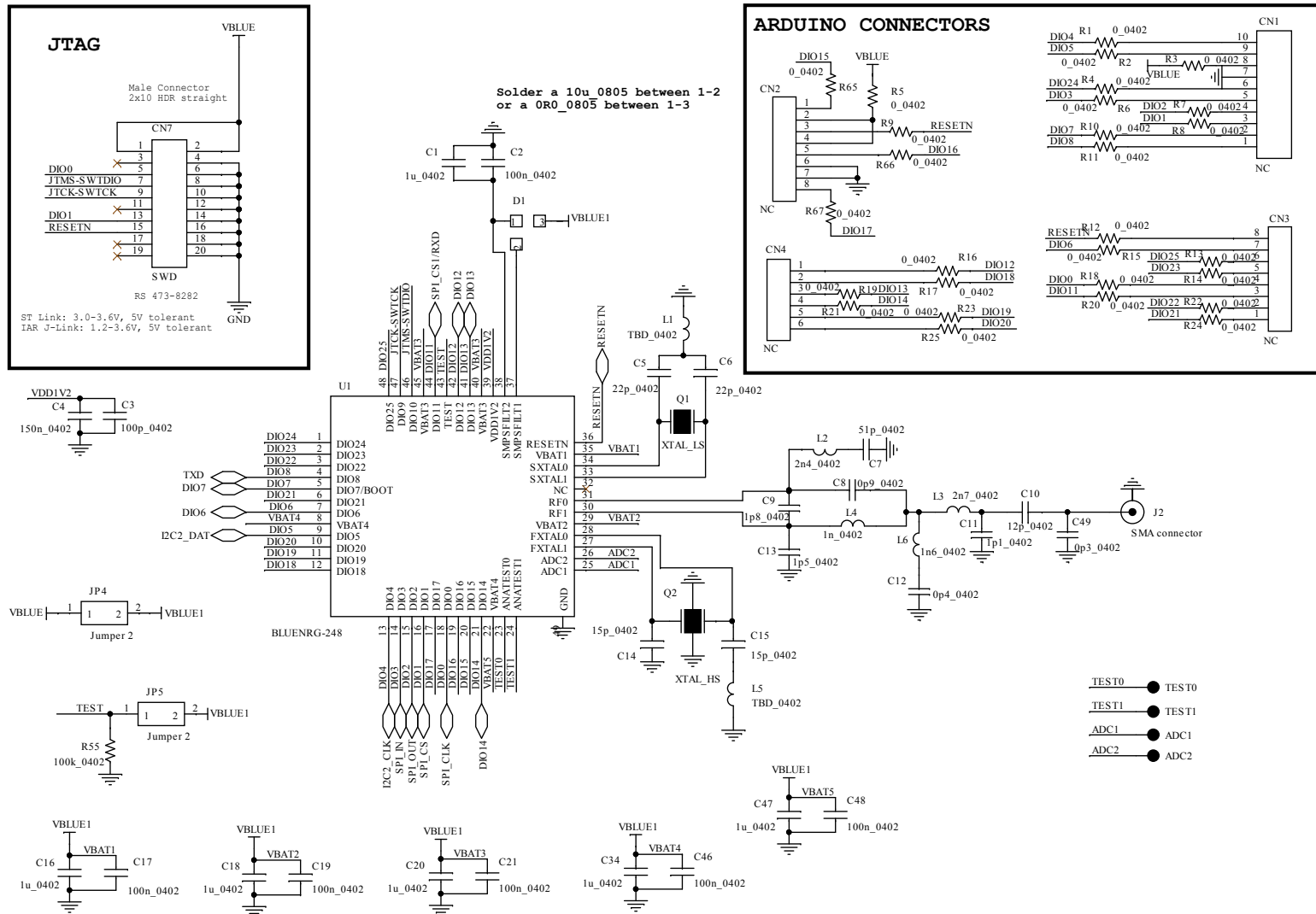

Figure 62. STEVAL-IDB009V1 board schematic (part 2)

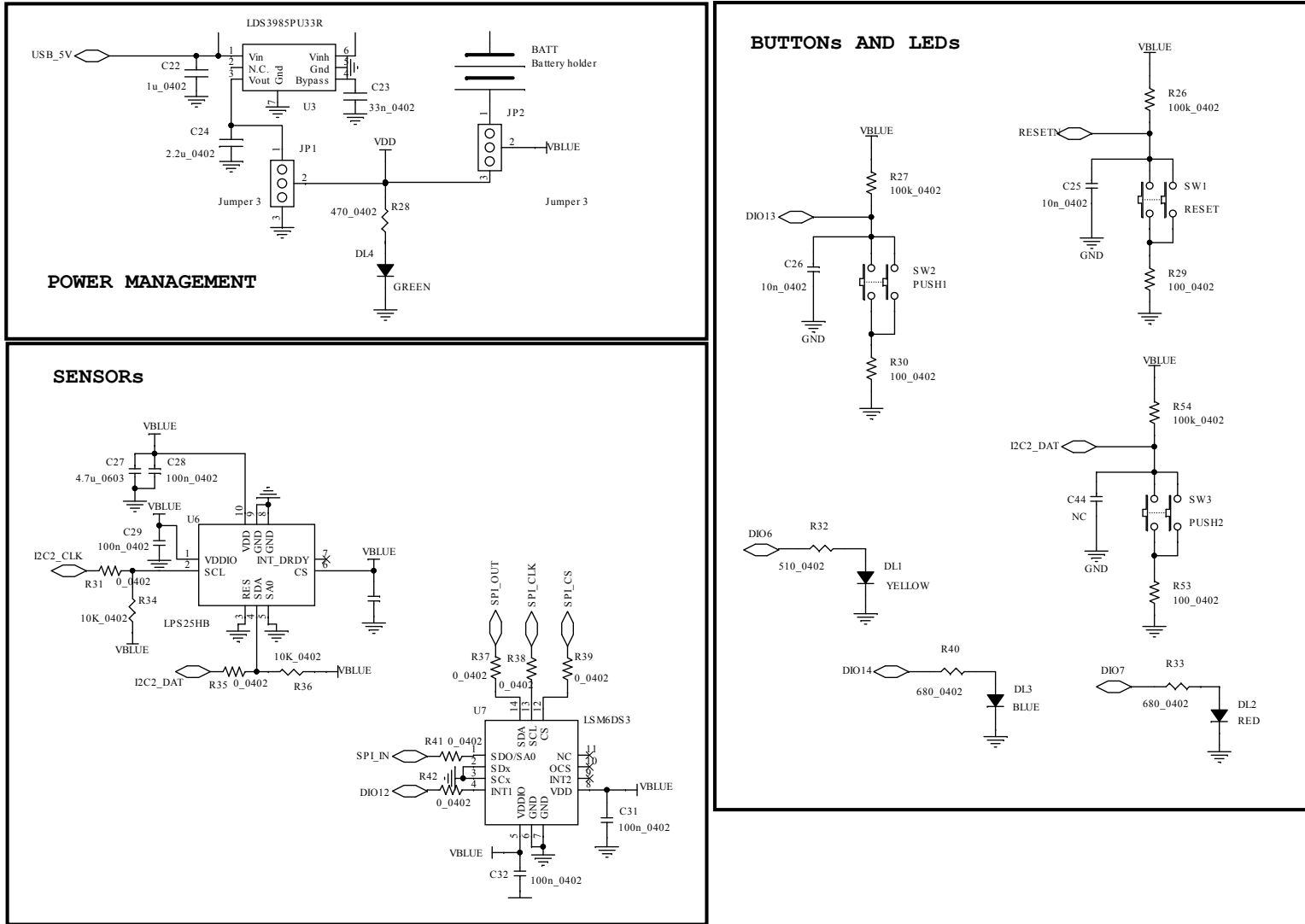
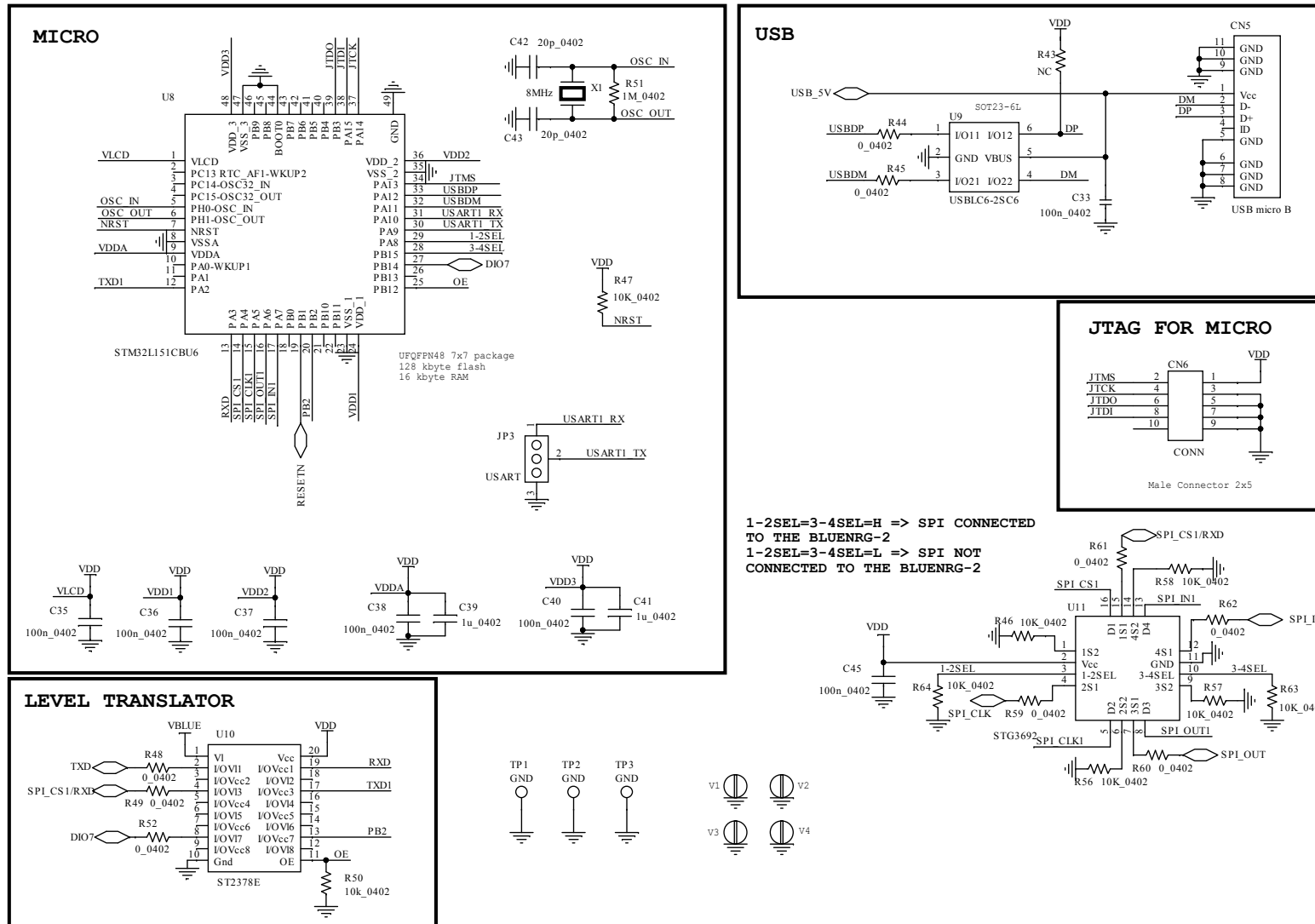

Figure 63. STEVAL-IDB009V1 board schematic (part 3)



Revision history

Table 10. Document revision history

Date	Version	Changes
06-Jun-2016	1	Initial release.
08-Nov-2016	2	Added Section 11: "BlueNRG-1 sensor profile central demo" and description for ADC DMA, PDM and MFT timers.
23-Dec-2016	3	Updated STEVAL-IDB007V1 development platform and STEVAL-IDB007V1 board components.
27-Jun-2017	4	Updated: Figure 10: "BLE demonstration and test applications", and Section 18.9: " SPI examples ". Added: Section 16: "BLE security demonstration applications", Section 17: "BLE power consumption demo application", Section 18.6: "Public Key Accelerator (PKA) demonstration application" and Section 18.7: "RNG examples". Added reference to BlueNRG-2 device and related SW components. Add reference to STEVAL-IDB008V1 kit and related schematics pictures.
17-Oct-2017	5	Added reference to BlueNRG-1-V1 DK SW package supporting BLE stack v1.x family.
17-Jan-2018	6	Added references to STEVAL-IDB007V2, STEVAL-IDB008V2 platforms and related schematics.
08-Jun-2018	7	Updated Figure 7. BlueNRG-1 Navigator, Figure 8. BLE Beacon application, Figure 9. BLE Beacon Flash programming, Figure 11. Basic examples, Figure 12. BLE demonstration and test applications, Figure 13. Peripherals driver examples, Figure 15. STEVAL-IDB007V2 kit components, Figure 16. BlueNRG-1 radio parameters wizard, Section 5.1 Software directory structure, Section 6.1.3 Entering non-connectable mode , Section 13.2 BLE bidirectional throughput scenario, Section 18.9 RTC examples , Section 18.13 UART examples and Section 19 Schematic diagrams. Added Section 2.11 Integrated balun with matching network and harmonics filter, Section 3.1.4 BlueNRG-1 Navigator '2.4 GHz radio proprietary examples', Section 17 BLE master and slave multiple connection demonstration application, Section 17.1 Application roles, Section 17.1.1 Master_Slave device role and Section 18.7 2.4 GHz radio proprietary examples. Removed BlueNRG-1 Flasher utility section.
20-Nov-2018	8	Throughout document added references to the STEVAL-IDB009V1 platform (BlueNRG-2 QFN48 package). Added Section 1 Development platforms, Figure 57. STEVAL-IDB009V1 schematic (1 of 3), Figure 58. STEVAL-IDB009V1 schematic (2 of 3), Figure 59. STEVAL-IDB009V1 schematic (3 of 3), Section 19 BLE Controller Privacy demonstration application and Section 19.1 Application scenario. Updated Introduction, Section 2.1 Kit contents, Section 3.1 STEVAL-IDB007Vx/STEVALIDB008Vx/ STEVAL-IDB009Vx board overview, Section 3.2 BlueNRG-1, BlueNRG-2 SoC connections, Section 20.7 2.4 GHz radio proprietary examples and Section 20.12 Timers examples.
08-Jan-2019	9	Updated reference to Start menu folder.
20-Mar-2019	10	Updated Section 3.5 Sensors. Removed references to BlueNRG-1-V1 DK SW package.
10-Mar-2020	11	Updated Section 2.2 System requirements, Figure 9. BlueNRG-1 Navigator, Figure 13. Basic examples, Figure 16. 2.4 GHz radio proprietary examples, Section 5 BlueNRG-X Radio Init Parameters Wizard, Section 5.1 How to run, Section 5.2 Main user interface window and Section 6.1 Software directory structure. Added Section 7.2 BLE Beacon FreeRTOS example.
03-Jun-2020	12	Throughout document: - added content and references relating to the STEVAL-IDB008V1M platform - minor text edits

Contents

1	Development platforms	2
2	Getting started	5
2.1	Kit contents	5
2.2	System requirements	5
2.3	BlueNRG-1, BlueNRG-2 development kits setup	5
3	Hardware description	6
3.1	STEVAL-IDB007Vx/STEVAL-IDB008Vx/STEVAL-IDB009Vx board overview	6
3.2	BlueNRG-1, BlueNRG-2 SoC connections	8
3.3	Power supply	10
3.4	Jumpers	11
3.5	Sensors	11
3.6	Extension connector	11
3.7	Push-buttons	11
3.8	JTAG connector	12
3.9	LEDs	12
3.10	STM32L151CUB6 microcontroller	12
3.11	Integrated balun with matching network and harmonics filter	12
3.12	Current measurements	12
3.13	Hardware setup	12
4	BlueNRG-1, BlueNRG-2 Navigator	13
4.1	BlueNRG-1 Navigator 'Demonstration Applications'	13
4.1.1	BlueNRG-1 Navigator 'Basic examples'	15
4.1.2	BlueNRG-1 Navigator 'BLE demonstration and test applications'	15
4.1.3	BlueNRG-1 Navigator 'Peripherals driver examples'	16
4.1.4	BlueNRG-1 Navigator '2.4 GHz radio proprietary examples'	16
4.2	BlueNRG-1 Navigator 'Development Kits'	17
4.2.1	BlueNRG-1 Navigator 'Release Notes' and 'License'	17
5	BlueNRG-X Radio Init Parameters Wizard	18
5.1	How to run	18

5.2	Main user interface window	18
6	Programming with BlueNRG-1, BlueNRG-2 system on chip.....	20
6.1	Software directory structure	20
7	BLE beacon demonstration application	21
7.1	BLE Beacon application setup	21
7.1.1	Initialization	21
7.1.2	Define advertising data	21
7.1.3	Entering non-connectable mode	21
7.2	BLE Beacon FreeRTOS example	22
8	BLE chat demo application	23
8.1	Peripheral and central device setup	23
8.1.1	Initialization	23
8.1.2	Add service and characteristics	24
8.1.3	Enter connectable mode	24
8.1.4	Connection with central device	24
9	BLE chat master and slave demo application.....	26
9.1	BLE chat master and slave roles.....	26
9.1.1	Initialization	26
9.1.2	Add service and characteristics	26
9.1.3	Start discovery procedure	26
9.1.4	Enter connectable mode	27
9.1.5	Connection with chat master and slave client device.....	27
10	BLE remote control demo application	28
10.1	BLE remote control application setup	28
10.1.1	Initialization	28
10.1.2	Define advertising data	28
10.1.3	Add service and characteristics	29
10.1.4	Connection with a BLE Central device	29
11	BLE sensor profile demo	30
11.1	BlueNRG app for smartphones	30
11.2	BLE sensor profile demo: connection with a central device.....	31

11.2.1	Initialization	31
11.2.2	Add service and characteristics.	31
11.2.3	Enter connectable mode	32
11.2.4	Connection with central device	32
12	BLE sensor profile central demo	33
13	BLE HID/HOGP demonstration application	34
13.1	BLE HID/HOGP mouse demonstration application.	34
13.2	BLE HID/HOGP keyboard demonstration application.	34
14	BLE throughput demonstration application	35
14.1	BLE unidirectional throughput scenario	35
14.2	BLE bidirectional throughput scenario	35
15	BLE notification consumer demonstration application.	37
16	BLE security demonstration applications	38
16.1	Peripheral device.	38
16.2	Central device	39
17	BLE power consumption demo application.	41
18	BLE master and slave multiple connection demonstration application	42
18.1	Application roles	42
18.1.1	Master_Slave device role	42
18.1.2	Master role	42
19	BLE Controller Privacy demonstration application	43
19.1	Application scenario	43
20	BlueNRG-1, BlueNRG-2 peripheral driver examples	44
20.1	ADC examples.	44
20.2	Flash example	44
20.3	GPIO examples	44
20.4	I ² C examples	45
20.5	Micro examples	45
20.6	Public Key Accelerator (PKA) demonstration application.	45
20.7	2.4 GHz radio proprietary examples	46

20.8	RNG examples	46
20.9	RTC examples	46
20.10	SPI examples	47
20.11	SysTick examples	47
20.12	Timers examples	47
20.13	UART examples	49
20.14	WDG examples	49
21	Schematic diagrams	50
21.1	STEVAL-IDB007V1 schematic digrams	51
21.2	STEVAL-IDB007V2 schematic digrams	59
21.3	STEVAL-IDB008V1 schematic digrams	62
21.4	STEVAL-IDB008V2 schematic digrams	71
21.5	STEVAL-IDB008V1M schematic digrams	80
21.6	STEVAL-IDB009V1 schematic digrams	83
	Revision history	86

List of figures

Figure 1.	STEVAL-IDB007V1 development platform	2
Figure 2.	STEVAL-IDB007V2 development platform	2
Figure 3.	STEVAL-IDB008V1 development platform	3
Figure 4.	STEVAL-IDB008V2 development platform	3
Figure 5.	STEVAL-IDB009V1 development platform	4
Figure 6.	STEVAL-IDB008V1M development platform	4
Figure 7.	STEVAL-IDB007Vx board components	6
Figure 8.	STEVAL-IDB008Vx board components	7
Figure 9.	STEVAL-IDB009V1 board components	7
Figure 10.	BlueNRG-1 Navigator	13
Figure 11.	BLE Beacon application	14
Figure 12.	BLE Beacon Flash programming	14
Figure 13.	BLE Beacon documentation	15
Figure 14.	Basic examples	15
Figure 15.	BLE demonstration and test applications	16
Figure 16.	Peripherals driver examples	16
Figure 17.	2.4 GHz radio proprietary examples	17
Figure 18.	STEVAL-IDB007V2 kit components	17
Figure 19.	BlueNRG-X Radio Init Parameters Wizard	18
Figure 20.	BLE chat client	25
Figure 21.	BLE chat server	25
Figure 22.	BLE sensor demo GATT database	30
Figure 23.	BlueNRG sensor app	31
Figure 24.	STEVAL-IDB007V1 Arduino connectors	51
Figure 25.	STEVAL-IDB007V1 JTAG	52
Figure 26.	STEVAL-IDB007V1 BlueNRG-1	53
Figure 27.	STEVAL-IDB007V1 power management, sensors	54
Figure 28.	STEVAL-IDB007V1 buttons and LEDs	55
Figure 29.	STEVAL-IDB007V1 micro	56
Figure 30.	STEVAL-IDB007V1 USB, level translator, JTAG for micro	57
Figure 31.	STEVAL-IDB007V1 switch	58
Figure 32.	STEVAL-IDB007V2 - scheme 1	59
Figure 33.	STEVAL-IDB007V2 - scheme 2	60
Figure 34.	STEVAL-IDB007V2 - scheme 3	61
Figure 35.	STEVAL-IDB008V1 circuit schematic - JTAG	62
Figure 36.	STEVAL-IDB008V1 circuit schematic - Arduino connectors	63
Figure 37.	STEVAL-IDB008V1 circuit schematic - BlueNRG-2	64
Figure 38.	STEVAL-IDB008V1 circuit schematic - buttons and LEDs	65
Figure 39.	STEVAL-IDB008V1 circuit schematic - sensors	66
Figure 40.	STEVAL-IDB008V1 circuit schematic - power management	66
Figure 41.	STEVAL-IDB008V1 circuit schematic - JTAG for MCU	67
Figure 42.	STEVAL-IDB008V1 circuit schematic - USB	67
Figure 43.	STEVAL-IDB008V1 circuit schematic - test points	67
Figure 44.	STEVAL-IDB008V1 circuit schematic - switch	68
Figure 45.	STEVAL-IDB008V1 circuit schematic - microcontroller	69
Figure 46.	STEVAL-IDB008V1 circuit schematic - level translator	70
Figure 47.	STEVAL-IDB008V2 - JTAG	71
Figure 48.	STEVAL-IDB008V2 - Arduino connection	72
Figure 49.	STEVAL-IDB008V2 circuit schematic	73
Figure 50.	STEVAL-IDB008V2 - power managements	74
Figure 51.	STEVAL-IDB008V2 - SENSORS	75
Figure 52.	STEVAL-IDB008V2 - buttons and leds	76

Figure 53.	STEVAL-IDB008V2 - micro	77
Figure 54.	STEVAL-IDB008V2 - USB	78
Figure 55.	STEVAL-IDB008V2 - JTAG for micro	78
Figure 56.	STEVAL-IDB008V2 - level translator	79
Figure 57.	STEVAL-IDB008V2 - Switch	79
Figure 58.	STEVAL-IBD008V1M circuit schematic (1 of 3)	80
Figure 59.	STEVAL-IBD008V1M circuit schematic (2 of 3)	81
Figure 60.	STEVAL-IBD008V1M circuit schematic (3 of 3)	82
Figure 61.	STEVAL-IDB009V1 board schematic	83
Figure 62.	STEVAL-IDB009V1 board schematic (part 2)	84
Figure 63.	STEVAL-IDB009V1 board schematic (part 3)	85

List of tables

Table 1.	STEVAL-IDB007Vx/STEVAL-IDB008Vx/STEVAL-IDB009Vx board component descriptions	7
Table 2.	BlueNRG-1, BlueNRG-2 pins description with board functions	8
Table 3.	STEVAL-IDB007Vx, STEVAL-IDB008Vx, STEVAL-IDB009Vx kit platform power supply modes	10
Table 4.	STEVAL-IDB007Vx, STEVAL-IDB008Vx, STEVAL-IDB009Vx kit platform jumpers	11
Table 5.	BlueNRG-1 Beacon advertising manufacturing data	21
Table 6.	Serial port configuration	23
Table 7.	BLE remote advertising data	28
Table 8.	BLE security demonstration applications security configurations combinations	38
Table 9.	Peripheral device advertising local name parameter value	38
Table 10.	Document revision history	86

IMPORTANT NOTICE – PLEASE READ CAREFULLY

STMicroelectronics NV and its subsidiaries (“ST”) reserve the right to make changes, corrections, enhancements, modifications, and improvements to ST products and/or to this document at any time without notice. Purchasers should obtain the latest relevant information on ST products before placing orders. ST products are sold pursuant to ST’s terms and conditions of sale in place at the time of order acknowledgement.

Purchasers are solely responsible for the choice, selection, and use of ST products and ST assumes no liability for application assistance or the design of Purchasers’ products.

No license, express or implied, to any intellectual property right is granted by ST herein.

Resale of ST products with provisions different from the information set forth herein shall void any warranty granted by ST for such product.

ST and the ST logo are trademarks of ST. For additional information about ST trademarks, please refer to www.st.com/trademarks. All other product or service names are the property of their respective owners.

Information in this document supersedes and replaces information previously supplied in any prior versions of this document.

© 2020 STMicroelectronics – All rights reserved