

PTX10016 Packet Transport Router Hardware Guide

Published
2021-07-13

Juniper Networks, Inc.
1133 Innovation Way
Sunnyvale, California 94089
USA
408-745-2000
www.juniper.net

Juniper Networks, the Juniper Networks logo, Juniper, and Junos are registered trademarks of Juniper Networks, Inc. in the United States and other countries. All other trademarks, service marks, registered marks, or registered service marks are the property of their respective owners.

Juniper Networks assumes no responsibility for any inaccuracies in this document. Juniper Networks reserves the right to change, modify, transfer, or otherwise revise this publication without notice.

PTX10016 Packet Transport Router Hardware Guide
Copyright © 2021 Juniper Networks, Inc. All rights reserved.

The information in this document is current as of the date on the title page.

YEAR 2000 NOTICE

Juniper Networks hardware and software products are Year 2000 compliant. Junos OS has no known time-related limitations through the year 2038. However, the NTP application is known to have some difficulty in the year 2036.

END USER LICENSE AGREEMENT

The Juniper Networks product that is the subject of this technical documentation consists of (or is intended for use with) Juniper Networks software. Use of such software is subject to the terms and conditions of the End User License Agreement ("EULA") posted at <https://support.juniper.net/support/eula/>. By downloading, installing or using such software, you agree to the terms and conditions of that EULA.

Table of Contents

[About This Guide | x](#)

1

Overview

PTX10016 System Overview | 2

- [PTX10016 Packet Transport Router Description | 2](#)
- [PTX10016 Components and Configurations | 15](#)
- [PTX10016 Component Redundancy | 17](#)
- [PTX10016 Hardware and CLI Terminology Mapping | 18](#)

PTX10016 Chassis | 22

- [PTX10016 Field-Replaceable Units | 22](#)
- [PTX10016 Status Panel | 24](#)
- [PTX10016 Optional Equipment | 28](#)

PTX10016 Cooling System | 30

- [PTX10016 Cooling System and Airflow | 30](#)
- [PTX10016 Fan Tray LEDs and Fan Tray Controller LEDs | 39](#)

PTX10016 Power System | 46

- [JNP10K-PWR-AC Power Supply | 47](#)
- [JNP10K-PWR-AC2 Power Supply | 50](#)
- [JNP10K-PWR-DC Power Supply | 53](#)
- [JNP10K-PWR-DC2 Power Supply | 55](#)
- [JNP10K-PWR-AC Power Supply LEDs | 58](#)
- [JNP10K-PWR-AC2 Power Supply LEDs | 61](#)
- [JNP10K-PWR-DC Power Supply LEDs | 64](#)
- [JNP10K-PWR-DC2 Power Supply LEDs | 67](#)

PTX10016 Routing and Control Board Components and Descriptions | 69

PTX10016 Routing and Control Board Description | 69

PTX10016 Routing and Control Board LEDs | 72

PTX10016 Switch Fabric | 78

PTX10016 Switch Interface Board Description | 78

PTX10016 Switch Interface Board LEDs | 82

PTX10016 Line Card Components and Descriptions | 83

PTX10K-LC1101 Line Card | 85

PTX10K-LC1102 Line Card | 88

PTX10K-LC1104 Line Card | 96

1.2-Terabyte Per Second DWDM OTN Module Wavelengths | 107

PTX10K-LC1105 Line Card | 133

QFX10000-60S-6Q Line Card | 136

PTX10016 Line-Card LEDs | 143

Taking a Line Card Offline | 144

2

Site Planning, Preparation, and Specifications

PTX10016 Site Preparation Overview | 147

PTX10016 Site Preparation Checklist | 147

PTX10016 Environmental Requirements and Specifications | 149

General Site Guidelines | 150

PTX10016 Site Electrical Wiring Guidelines | 151

PTX10016 Rack Requirements | 152

PTX10016 Clearance Requirements for Airflow and Hardware Maintenance | 155

PTX10016 Chassis Physical Specifications | 156

PTX10016 Power Planning | 160

Power Requirements for PTX10016 Components | 161

Calculate Power Requirements for a PTX10016 Router | 162

How to Calculate the Power Consumption of Your PTX10016 Configuration | 163

How to Calculate the Number of Power Supplies Required for Your PTX10016 Configuration | 167

JNP10K-PWR-AC Power Specifications | 172

JNP10K-PWR-AC2 Power Specifications | 173

PTX10016 Power Cables Specifications | 174

JNP10K-PWR-DC Power Specifications | 184

JNP10K-PWR-DC2 Power Specifications | 185

PTX10016 Grounding Cable and Lug Specifications | 187

PTX10016 Transceiver and Cable Specifications | 188

PTX10016 Optical Transceiver and Cable Support | 188

PTX10016 Cable Specifications for Console and Management Connections | 189

PTX10016 Fiber Optic Cable Signal Loss, Attenuation, and Dispersion | 190

Calculate the Fiber-Optic Cable Power Budget for a PTX10016 Router | 191

Calculate the Fiber-Optic Cable Power Margin for a PTX10016 Router | 192

PTX10016 Console and Management Cable Specifications and Pinouts | 194

Console Port Connector Pinouts for a PTX10016 | 194

USB Port Specifications for the PTX10016 Routers | 196

Management Port Connector Pinouts for the PTX10016 Router | 196

3

Initial Installation and Configuration

PTX10016 Installation Overview | 199

Unpack the PTX10016 | 200

Unpack the PTX10016 Shipping Pallet | 200

Unpack Line Cards, Routing Control Boards, and Switch Interface Boards for the PTX10016 | 203

Compare the PTX10016 Order to the Packing List | 204

Register Products—Mandatory to Validate SLAs | 210

Install the Mounting Hardware for a PTX10016 | 210

Mount a PTX10016 in a Four-Post Rack Using a Mechanical Lift | 213

Install the Front Door on a PTX10016 Router | 216

Connect the PTX10016 to Power | 224

Connect a PTX10016 Router to Earth Ground | 224

Connect AC Power to the PTX10016 Router | 227

Connect DC Power to a PTX10016 Router | 228

Connect the PTX10016 to External Devices | 229

Connect a PTX10016 Router to a Network for Out-of-Band Management | 230

Connect a PTX10016 Router to a Management Console | 231

Perform the Initial Configuration for the PTX10016 Router | 232

Before You Start | 232

Enter Configuration Mode | 233

Establish a Root Password and Optional Host Name | 234

Configure the Default Gateway and Ethernet Interface | 234

Configure Optional Routes, Services, and Commit the Configuration | 235

4

Maintaining Components

Install and Remove PTX10016 Routing and Control Boards | 238

Install a PTX10016 Routing and Control Board | 238

Remove a PTX10016 Routing and Control Board | 241

Install and Remove PTX10016 Cooling System Components | 242

Install a PTX10016 Fan Tray | 243

Remove a PTX10016 Fan Tray | 246

Install a PTX10016 Fan Tray Controller | 251

Remove a PTX10016 Fan Tray Controller | 254

Install and Remove PTX10016 Power System Components | 257

Install a JNP10K-PWR-AC Power Supply | 258

Remove a JNP10K-PWR-AC Power Supply | 263

Install a JNP10K-PWR-AC2 | 267

Remove a JNP10K-PWR-AC2 Power Supply | 271

Install a JNP10K-PWR-DC Power Supply | 274

Remove a JNP10K-PWR-DC Power Supply | 283

Install a JNP10K-PWR-DC2 Power Supply | 286

Remove a JNP10K-PWR-DC2 Power Supply | 297

Install and Remove PTX10016 Switch Fabric Components | 300

How to Handle and Store PTX10016 Line Cards, RCBs, and SIBs | 300

How to Hold Line Cards and RCBs | 300

How to Hold SIBs | 302

How to Store Line Cards, RCBs, and SIBs | 303

Install a PTX10016 Switch Interface Board | 303

Remove a PTX10016 Switch Interface Board | 307

Install and Remove PTX10016 Line Card Components | 311

Install a PTX10016 Line Card | 312

Remove a PTX10016 Line Card | 315

Install the PTX10016 Cable Management System | 318

PTX10016 Transceiver and Fiber-Optic Cable Installation and Removal | 323

PTX10016 Transceiver Installation | 323

PTX10016 Transceiver Removal | 325

How to Connect a Fiber-Optic Cable from a Transceiver on a PTX10016 Router | 327

How to Disconnect a Fiber-Optic Cable from a Transceiver on a PTX10016 Router | 328

How to Maintain Fiber-Optic Cable for a PTX10016 Router | 329

Remove the PTX10016 Router from the Rack | 330

Power Off a PTX10016 Router | 330

Remove the PTX10016 from a Four-Post Rack Using a Mechanical Lift | 333

6

Alarm Messages | 337

Alarms – A Glossary | 337

Interface Alarm Messages | 338

Contacting Customer Support and Returning the Chassis or Components**Contact Customer Support | 341****Return Procedures for the PTX10016 Chassis and Components | 342**

Return a PTX10016 Router or Component for Repair or Replacement | 342

Locate the Serial Number on a PTX10016 Router or Component | 343

List the PTX10016 Chassis and Component Details Using the CLI | 344

Locate the Chassis Serial Number on a PTX10016 | 346

Locate the Serial Number ID Labels on PTX10016 Power Supplies | 347

Locate the Serial Number ID Labels on PTX10016 Fan Trays and Fan Tray Controllers | 350

Locate the Serial Number ID Labels on PTX10016 Routing and Control Boards | 352

Locate the Serial Number ID Labels on a PTX10016 Line Card | 353

Locate the Serial Number ID Labels on a PTX10016 Switch Interface Board (SIB) | 353

Locate the Serial Number ID Label on a PTX10016 SATA SSD | 354

Contact Customer Support to Obtain a Return Materials Authorization for a PTX10016 Router or Component | 354

How to Pack a PTX10016 or Component for Shipping | 355

How to Pack a PTX10016 Chassis for Shipping | 356

How to Pack PTX10016 Components for Shipping | 359

7

Safety and Compliance Information**General Safety Guidelines and Warnings | 363****Definitions of Safety Warning Levels | 364****Qualified Personnel Warning | 366****Warning Statement for Norway and Sweden | 366****Fire Safety Requirements | 367****Installation Instructions Warning | 368**

PTX10016 Chassis Lifting Guidelines	369
Restricted Access Warning	369
Ramp Warning	371
Rack-Mounting and Cabinet-Mounting Warnings	371
Grounded Equipment Warning	375
Radiation from Open Port Apertures Warning	376
Laser and LED Safety Guidelines and Warnings	377
Maintenance and Operational Safety Guidelines and Warnings	380
General Electrical Safety Guidelines and Warnings	386
Action to Take After an Electrical Accident	387
Prevention of Electrostatic Discharge Damage	388
AC Power Electrical Safety Guidelines	389
AC Power Disconnection Warning	390
DC Power Electrical Safety Guidelines for PTX10008 and PTX10016 Routers	391
DC Power Copper Conductors Warning	392
DC Power Disconnection Warning	393
DC Power Grounding Requirements and Warning	394
DC Power Wiring Sequence Warning	395
DC Power Wiring Terminations Warning	397
Multiple Power Supplies Disconnection Warning	398
TN Power Warning	399
Fire Safety Requirements	400
PTX10008 and PTX10016 Agency Approvals and Compliance Statements	401
Agency Approvals for the PTX10008 and PTX10016 Routers	401
Compliance Statements for EMC Requirements for the PTX10008 and PTX10016 Routers	403

About This Guide

Use this guide to install hardware and perform initial software configuration, routine maintenance, and troubleshooting for the PTX10016 Packet Transport Router.

After completing the installation and basic configuration procedures covered in this guide, refer to the Junos OS documentation for information about further software configuration.

RELATED DOCUMENTATION

[PTX10016 Quick Start](#)

[Junos OS for PTX Series Packet Transport Routers](#)

1

CHAPTER

Overview

[PTX10016 System Overview | 2](#)

[PTX10016 Chassis | 22](#)

[PTX10016 Cooling System | 30](#)

[PTX10016 Power System | 46](#)

[PTX10016 Routing and Control Board Components and Descriptions | 69](#)

[PTX10016 Switch Fabric | 78](#)

[PTX10016 Line Card Components and Descriptions | 83](#)

PTX10016 System Overview

IN THIS SECTION

- [PTX10016 Packet Transport Router Description | 2](#)
- [PTX10016 Components and Configurations | 15](#)
- [PTX10016 Component Redundancy | 17](#)
- [PTX10016 Hardware and CLI Terminology Mapping | 18](#)

The Juniper Networks PTX10016 line of packet transport routers bring physical and virtual innovations to the service provider core network. These next-generation routers help network operators achieve their business goals while effectively handling current and future traffic demands.

PTX10016 Packet Transport Router Description

IN THIS SECTION

- [Benefits of the PTX10016 Router | 3](#)
- [Chassis Description | 4](#)
- [Routing and Control Board | 7](#)
- [Line Cards | 8](#)
- [Switch Interface Boards | 9](#)
- [Cooling System | 10](#)
- [Power Supplies | 12](#)
- [Software | 14](#)

The Juniper Networks PTX10016 Packet Transport Router provides cloud and data center operators with the highest levels of scale and throughput. The PTX10016 can provide 48 terabits per second (Tbps) of throughput and 32 Bpps of forwarding capacity in a 21-rack-unit (21-U) chassis. PTX10016 has 16 slots for line cards that allow for a smooth transition from 10-Gigabit Ethernet and 40-Gigabit

Ethernet networks to 100-Gigabit Ethernet high-performance networks. [Table 1 on page 3](#) shows the supported port densities.

Table 1: PTX10016 Port Densities

Port Density	Maximum
10-Gigabit Ethernet	2304
40-Gigabit Ethernet	576
100-Gigabit Ethernet	480

The PTX10016 can be deployed in various network designs and fabrics, including:

- Label-Switched core routing
- IP core
- Peering

The PTX10016 is available in both base and redundant configurations for both AC and DC operations. All systems feature front-to-back airflow, which is also known as airflow out (AFO).

This topic covers:

Benefits of the PTX10016 Router

- **System capacity**—The PTX10016 packet transport router has a 21 RU form factor and supports 48 Tbps per chassis or 3 Tbps per slot, with support for up to 480 100-Gigabit Ethernet interfaces, 576 40-Gigabit Ethernet ports, or 2304 10-Gigabit Ethernet ports in a single chassis.
- **Full-scale IP and MPLS routing**—PTX10016 delivers the distributed peering scale of 2.9 million forwarding information bases (FIBs) and 30 million routing information bases (RIBs) (also known as forwarding tables, and routing tables, respectively), 3000 OSPF adjacencies, and 4000 BGP sessions that are required to match expanding traffic demands.
- **Source Packet Routing in Networking (SPRING)**—SPRING on PTX10016 provides additional flexibility per packet source. SPRING provides network path and node protection to support MPLS fast reroute (FRR) mechanisms, enhanced network programmability, Operation, Administration, and Maintenance (OAM) functionality, simplified network signaling, load balancing, and traffic engineering functions.

- **Always-on infrastructure base**—The PTX10016 is engineered with full hardware redundancy for cooling, power, switch fabric, and host subsystems—Routing and Control Boards (RCBs)—allowing service providers to meet stringent service-level agreements across the core.
- **Nondisruptive software upgrades**—The Junos operating system (Junos OS) on the PTX10016 supports high availability (HA) features such as graceful Routing Engine switchover (GRES), and nonstop active routing (NSR) providing software upgrades and changes without disrupting network traffic.

Chassis Description

The PTX10016 is 21 U tall. Two PTX10016 chassis can fit in a standard 42-U rack with adequate cooling and power. All key PTX10016 components are field-replaceable units (FRUs). [Figure 1 on page 5](#) illustrates the components visible from the front of the chassis, [Figure 2 on page 6](#) illustrates the

components that are visible from the rear of the chassis, and [Figure 3 on page 7](#) illustrates the components that are internal to the chassis.

Figure 1: PTX10016 Chassis Front

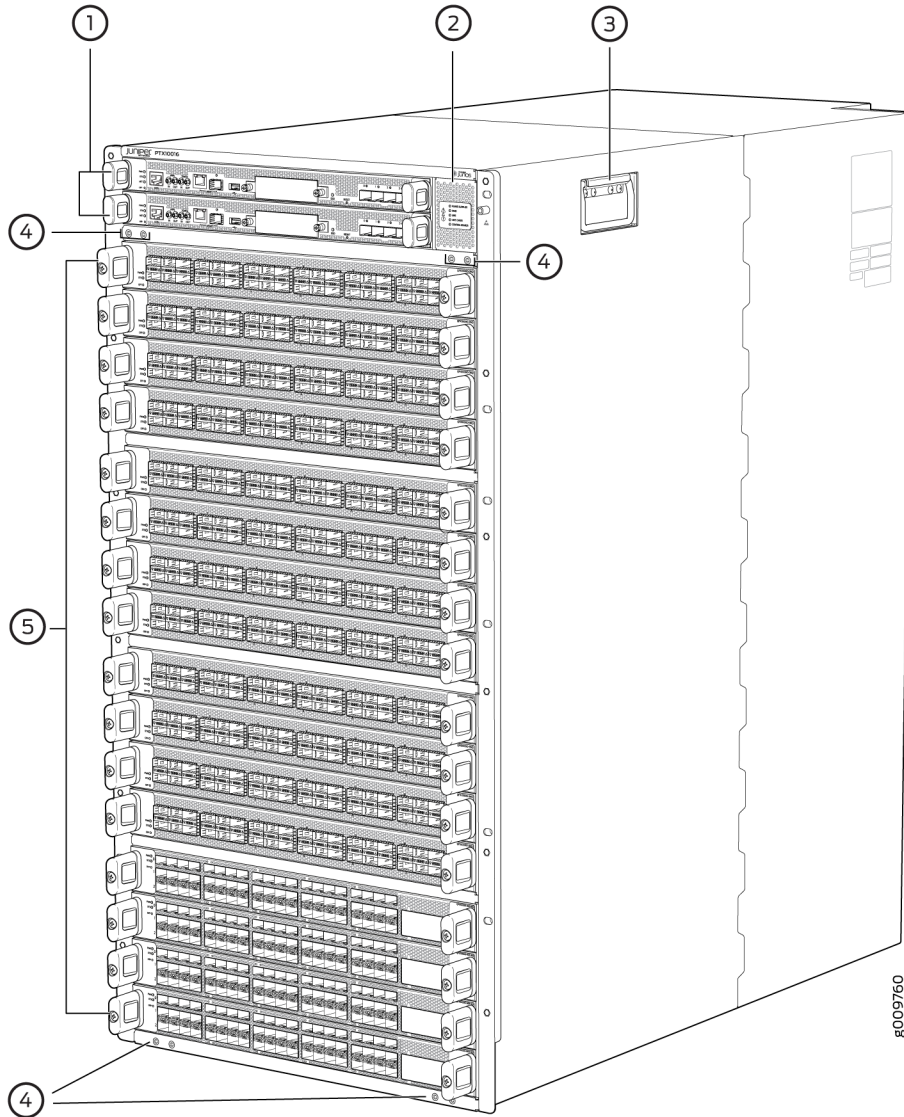

1– Routing and Control Boards

2– Status LED panel

3– Handle

4– Installation holes for the front panel

5– Line card slots 0-15 (numbered top to bottom)

Some chassis ship with an enhanced power bus to support future-proof the chassis beyond the current generation of line cards. You can determine which chassis you have by markings on the status panel, (see ["PTX10016 Status Panel" on page 24](#)).

Figure 2: PTX10016 Chassis Rear

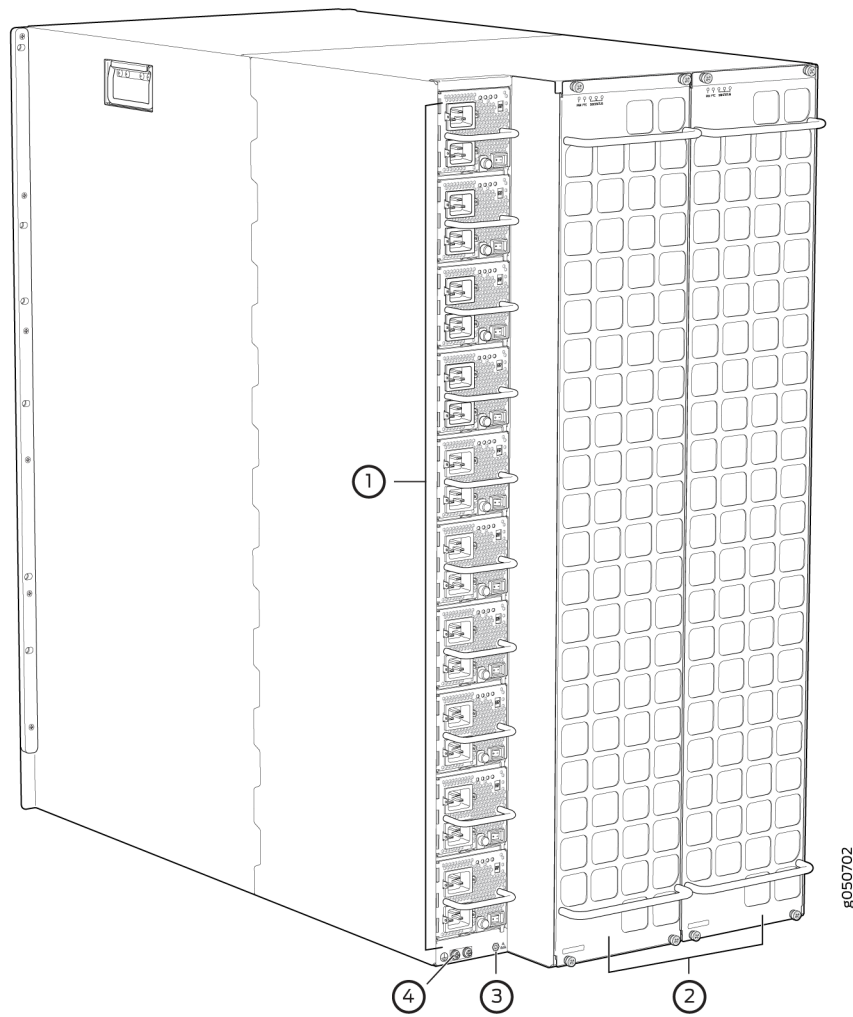

1– AC or DC power supplies

3– ESD point

2– Fan trays with redundant fans

4– Protective earthing terminal

Figure 3: PTX10016 Chassis Internal Components

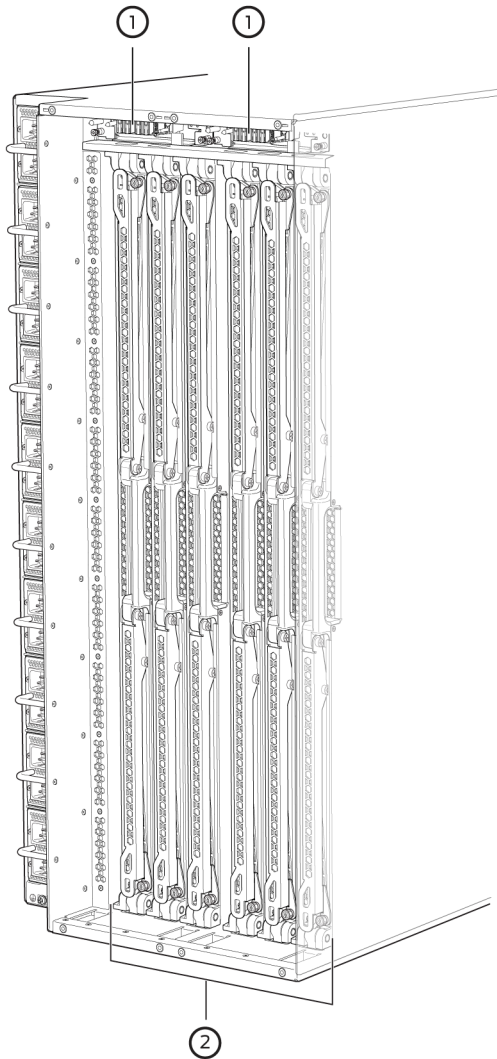

1– Fan tray controllers

2– Switch Interface Boards (SIBs)

See ["PTX10016 Chassis Physical Specifications"](#) on page 156 and ["PTX10016 Field-Replaceable Units"](#) on page 22.

Routing and Control Board

The Routing and Control Board (RCB) (see [Figure 4 on page 8](#)) contains a Routing Engine and is responsible for the system management and system control in the PTX10016. See ["PTX10016 Routing](#)

and [Control Board Description](#)" on page 69. RCBs are FRUs that are installed in the front of the chassis in the slots labeled **CB0** and **CB1**. The base configuration has a single RCB. The fully redundant configuration has two RCBs. RCB contains Precision Time Protocol (PTP) ports and four Media Access Control Security (MACsec) capable ports. See "[PTX10016 Components and Configurations](#)" on page 15.

Figure 4: PTX10016 Routing and Control Board

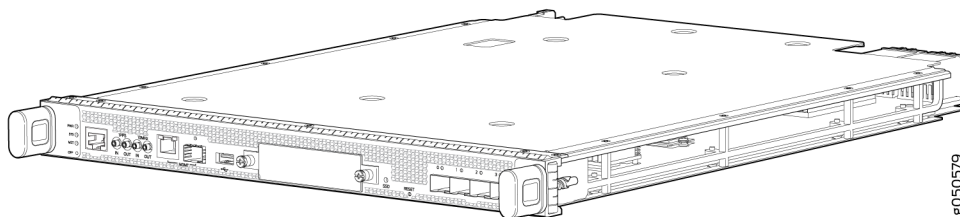

The supported models of RCB are:

- JNP10K-RE0
- JNP10K-RE1
- JNP10K-RE1-LT
- JNP10K-RE1-128G

Line Cards

The PTX10016 features 16 horizontal line card slots and supports line rate for each line card. The line cards combine a Packet Forwarding Engine and Ethernet interfaces enclosed in a single assembly. The line card architecture for PTX10016 routers is based on a number of identical, independent PFE slices, each with 500-Gbps full-duplex throughput. Line cards are FRUs that can be installed in the line card slots labeled **0** through **15** (top to bottom) on the front of the router chassis. All line cards are hot-removable and hot-insertable.

The PTX10016 supports the following line card models:

- PTX10K-LC1101, a 30-port 100-Gigabit or 40-Gigabit Ethernet quad small form-factor 28 (QSFP28) line card. By default, the interfaces are created with 100-Gbps port speed. Using the CLI, you can set the speed to 40-Gbps that can be used as either a native 40-gigabit interface or four independent 10-gigabit interfaces using a breakout cable. With breakout cables, the line card supports a maximum of 96 logical 10-Gigabit Ethernet interfaces.
- PTX10K-LC1102, a 36-port 40-Gigabit Ethernet line card that supports quad small form-factor plus (QSFP+) transceivers. Twelve out of the 36 ports on this line card also support the 100-Gigabit

Ethernet QSFP28 transceivers. You can configure each of the QSFP+ ports as either a native 40-Gigabit Ethernet interface or channelize the port as four 10-Gigabit Ethernet interfaces by using a breakout cable. When the 40 Gigabit Ethernet port is channelized, the line card supports a maximum of 144 logical 10-Gigabit Ethernet ports.

- PTX10K-LC1104, a 6-port coherent dense wavelength-division multiplexing (DWDM) line card with Media Access Control Security (MACsec). The line card features built-in optics that support flexible rate modulation at 100-Gbps, 150-Gbps, and 200-Gbps speeds.
- PTX10K-LC1105, a 30-port flexible configuration line card that supports QSFP+, QSFP28, QSFP28-DD, QSFP56, and QSFP-DD transceivers. You can configure either as 100-Gigabit Ethernet interfaces or as 40-Gigabit Ethernet interfaces. The PTX10K-LC1105 line card supports MACsec security features.

See [Figure 5 on page 9](#) for an example of a PTX10016 line card.

Figure 5: PTX10K-LC1101 Line Card

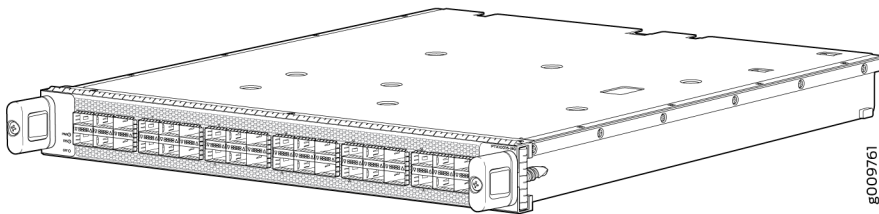

Switch Interface Boards

Five Switch Interface Boards (SIBs) provide the necessary switch fabric to a base configuration PTX10016 (see [Figure 6 on page 10](#)). A sixth SIB is available in the redundant configuration to provide $n+1$ redundancy. SIBs are installed between the line cards and the fan trays inside the chassis. Each PTX10016 SIB has 16 connectors that match to a line card slot, eliminating the need for a backplane.

When all six SIBs are installed, the PTX10016 has a net switching capacity of 96 Tbps. See ["PTX10016 Switch Interface Board Description"](#) on page 78.

Figure 6: PTX10016 SIB

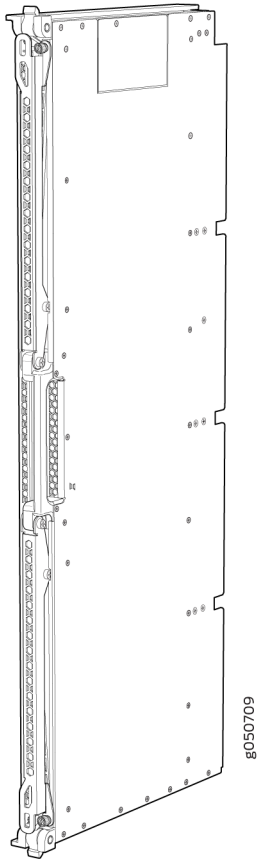

Cooling System

The cooling system in a PTX10016 consists of two hot-removable and hot-insertable FRU fan trays (see [Figure 7 on page 11](#)) and two fan tray controllers (see [Figure 8 on page 11](#)). Each fan tray contains 21

fans. The fan trays install vertically on the rear of the chassis and provide front-to-back chassis cooling. See "[PTX10016 Cooling System and Airflow](#)" on page 30.

Figure 7: Fan Tray JNP10016-FAN

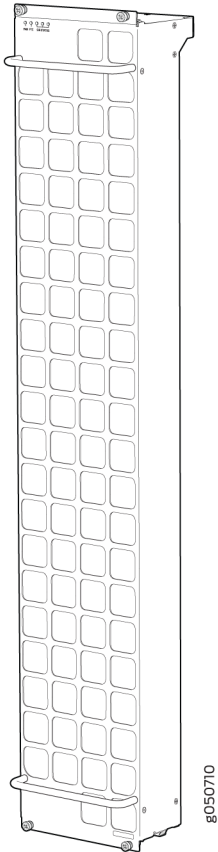
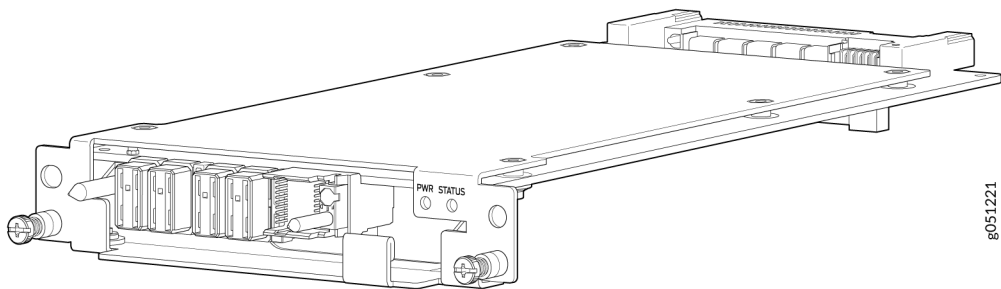

Figure 8: Fan Tray Controller JNP10016-FAN-CTRL



Power Supplies

PTX10016 routers support AC, DC, high-voltage alternating current (HVAC) and high-voltage direct current (HVDC) by offering the following power supplies:

- JNP10K-PWR-AC
- JNP10K-PWR-AC2
- JNP10K-PWR-DC
- JNP10K-PWR-DC2

Power supplies for the PTX10016 router are fully redundant, load-sharing, and hot-removable and hot-insertable FRUs. Each PTX10016 base configuration has five power supplies; redundant configurations hold the maximum of ten AC, HVAC, DC, or HVDC power supplies. Each power supply has an internal fan for cooling. You can install the power supplies in any slot. See [Table 2 on page 12](#) and [Figure 9 on page 13](#) through [Figure 12 on page 14](#).

[Table 2 on page 12](#) provides an overview of the differences among the power supplies.

Table 2: Power Supply Overview

Power Supply Model	Input Type	Wattage	Minimum Junos OS Release
JNP10K-PWR AC	AC only	2700 W	Junos OS 17.4R1
JNP10K-PWR-AC2	AC, HVAC, or HVDC	5000 W, single feed; 5500 W, dual feed	Junos OS 18.2R1
JNP10K-PWR DC	DC only	2500 W	Junos OS 17.4R1
JNP10K-PWR-DC2	DC only	2750 W, single feed; 5500 W, dual feed	Junos OS 18.2R1



CAUTION: Do not mix power supply models in the same chassis in a running environment. DC and HVDC power supplies can coexist in the same chassis when you hot swap of DC for an HVDC model. The system provides $2n$ source redundancy and n

+1 power supply redundancy. If one power source fails, the power supply switches to the alternate source.

Figure 9: JNP10K-PWR-AC Power Supply

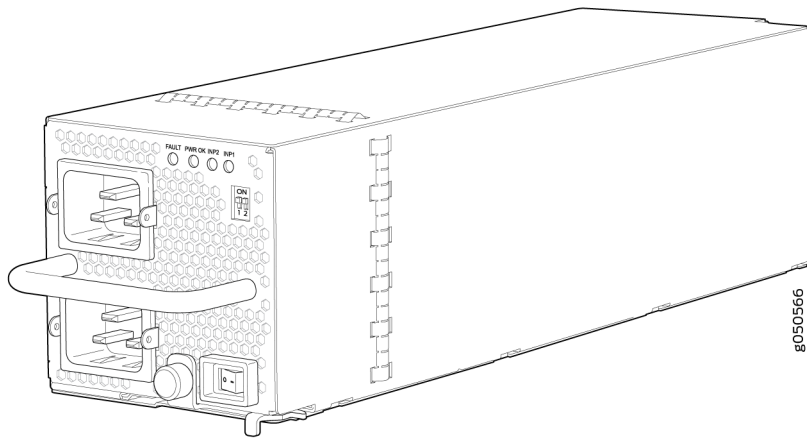

Figure 10: JNP10K-PWR-AC2 Power Supply

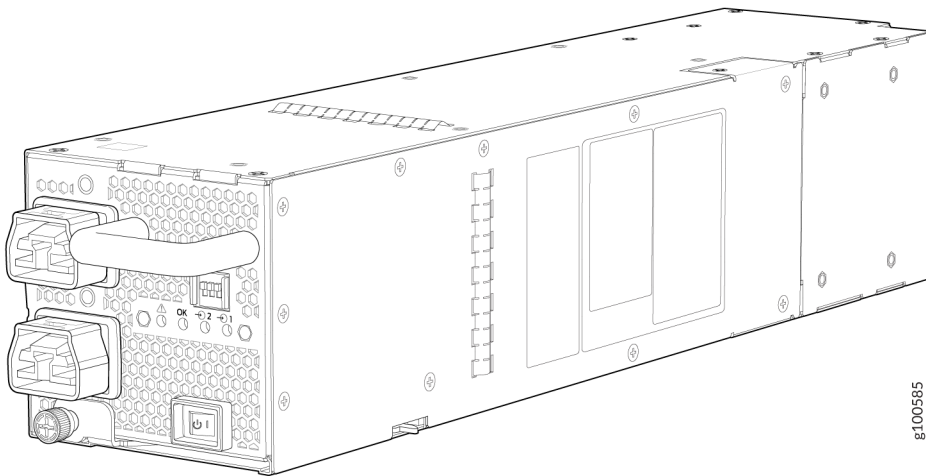

Figure 11: JNP10K-PWR-DC Power Supply

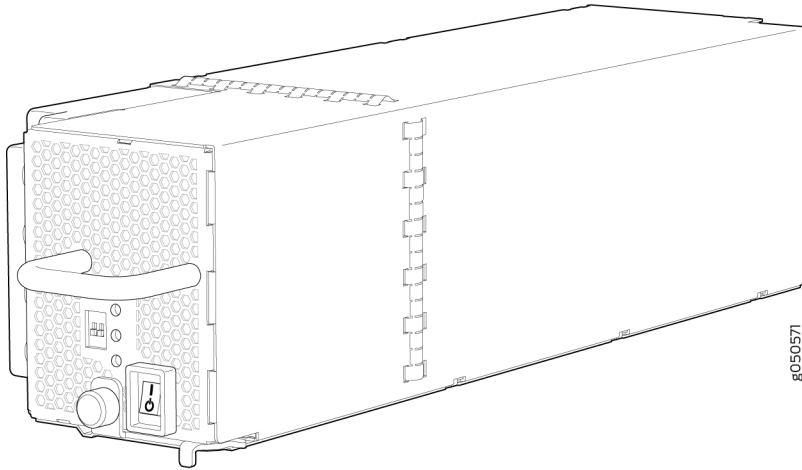
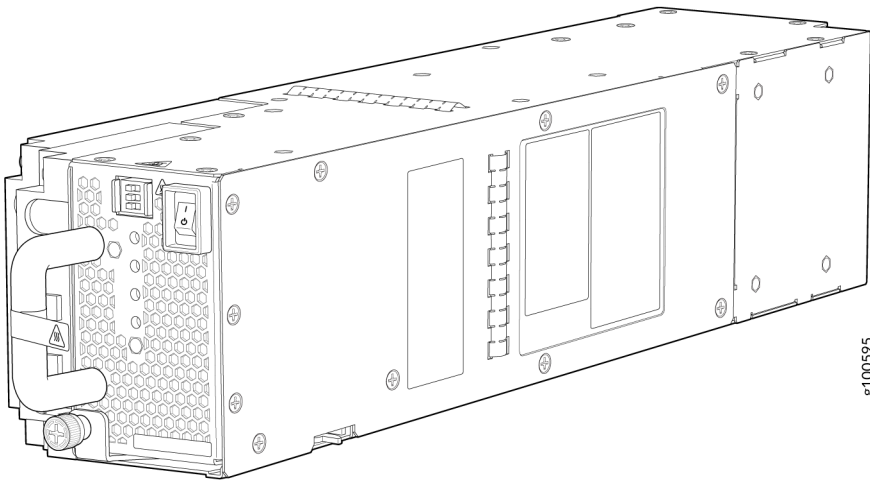

Figure 12: JNP10K-PWR-DC2 Power Supply



Software

The Juniper Networks PTX10016 line of Packet Transport Routers run Junos OS, which provides Layer 3 routing services. The same Junos OS code base that runs on the PTX10016 line of routers also runs on all Juniper Networks EX Series Ethernet Switches, M Series Multiservice Edge Routers, MX Series 5G universal Routing Platforms, and SRX Series Services Gateways.

PTX10016 Components and Configurations

Table 3 on page 15 lists the four hardware configurations for a PTX10016 modular chassis—base (AC version), and redundant (AC and DC versions)—and the components included in each configuration.

Table 3: PTX10016 Hardware Configurations

Router Configuration	Configuration Components
Base AC configuration PTX10016-BASE	<ul style="list-style-type: none"> • Chassis • One Routing and Control Board (RCB) • Two fan tray controllers (JNP10016-FAN-CTRL or JNP10016-FTC2) • Two fan trays (JNP10016-FAN and JNP10016-FAN2) • Five AC power supplies (JNP10K-PWR-AC or JNP10K-PWR-AC2) • Five power supply cover panels • Five Switch Interface Boards (SIBs) • One SIB cover panel • Sixteen line card cover panels

Table 3: PTX10016 Hardware Configurations (*Continued*)

Router Configuration	Configuration Components
Base DC configuration PTX10016-BASE	<ul style="list-style-type: none"> • Chassis • One RCB • Two fan tray controllers (JNP10016-FAN-CTRL or JNP10016-FTC2) • Two fan trays (JNP10016-FAN and JNP10016-FAN2) • Five DC power supplies (JNP10K-PWR-DC, JNP10K-PWR-DC2, or JNP10K-PWR-AC2) • Five power supply covers • Five SIBs • One SIB cover • Sixteen line card covers
Redundant AC configuration PTX10016-PREMIUM	<ul style="list-style-type: none"> • Chassis • Two RCBs • Two fan tray controllers (JNP10016-FAN-CTRL or JNP10016-FTC2) • Two fan trays (JNP10016-FAN and JNP10016-FAN2) • Ten AC power supplies (JNP10K-PWR-AC or JNP10K-PWR-AC2) • Six SIBs • Sixteen line card covers

Table 3: PTX10016 Hardware Configurations (*Continued*)

Router Configuration	Configuration Components
Redundant DC configuration PTX10016-PREMIUM	<ul style="list-style-type: none"> • Chassis • Two RCBs • Two fan tray controllers (JNP10016-FAN-CTRL or JNP10016-FTC2) • Two fan trays (JNP10016-FAN and JNP10016-FAN2) • Ten DC power supplies (JNP10K-PWR-DC, JNP10K-PWR-DC2, or JNP10K-PWR-AC2) • Six SIBs • Sixteen line card covers

NOTE: You can install up to 16 line cards (any combination of line cards) in the PTX10016.

NOTE: Line cards and the cable management system are not part of the base or redundant configurations. You must order them separately.

NOTE: If you want to purchase additional power supplies (AC, DC, or HVAC or HVDC), SIBs, or RCBs for your router configuration, you must order them separately.

PTX10016 Component Redundancy

The PTX10016 router is designed so that no single point of failure can cause the entire system to fail. The following major hardware components in the redundant configuration provide redundancy:

- Routing and Control Board (RCB)—RCB consolidates the Routing Engine function with control plane function in a single unit. The PTX10016 routers can have one or two RCBs. When two RCBs are installed, one functions as the primary and the other functions as the backup. If the primary RCB (or

either of its components) fails, the backup can take over as the primary. See ["PTX10016 Routing and Control Board Description"](#) on page 69.

- **Switch Interface Boards (SIBs)**—The PTX10016 routers have six SIB slots. Five SIBs are required for base operation and the sixth SIB provides $n+1$ redundancy. All six SIBs are active and can sustain full throughput rate. The fabric plane can tolerate one SIB failure without any loss of performance. See the ["PTX10016 Switch Interface Board Description"](#) on page 78.
- **Power supplies**—The PTX10016 routers require three power supplies for minimum operation (two RCBs, two fan trays, six SIBs and no line cards). Additional power supplies provide $n+1$ redundancy for the system. AC, DC, HVAC, and HVDC systems tolerate a single power supply to fail without system interruption. If one power supply fails in a fully redundant system, the other power supplies can provide full power to the PTX10016 indefinitely.

The PTX10016 routers also support power source redundancy. Two sets of lugs are provided for the JNP10K-PWR-AC cables, four sets of lugs are provided for the JNP10K-PWR-DC2 cables, and two AC power cords are provided for each JNP10K-PWR-AC power supply.

- **Cooling system**—The fan trays have redundant fans, which are controlled by the fan tray controller. If one of the fans fails, the host subsystem increases the speed of the remaining fans to provide sufficient cooling for the router indefinitely. See ["PTX10016 Cooling System and Airflow"](#) on page 30.

PTX10016 Hardware and CLI Terminology Mapping

This topic describes the hardware terms used in PTX10016 router documentation and the corresponding terms used in the Junos OS CLI. See [Table 4 on page 18](#).

Table 4: CLI Equivalents of Terms Used in Documentation for PTX10016 Routers

Hardware Item (CLI)	Description (CLI)	Value (CLI)	Item In Documentation	Additional Information
Chassis	PTX10016	-	Router chassis	"PTX10016 Chassis Physical Specifications" on page 156

Table 4: CLI Equivalents of Terms Used in Documentation for PTX10016 Routers (*Continued*)

Hardware Item (CLI)	Description (CLI)	Value (CLI)	Item In Documentation	Additional Information
Fan tray	JNP10016-FAN or JNP10016-FAN2	Fan Tray $\theta/1$ Fan n n is a value in the range of 0–10 for the JNP10016-FAN, or JNP10016-FAN2. The value corresponds to the individual fan number in the fan tray.	Fan tray	"PTX10016 Cooling System and Airflow" on page 30
FPC (n)	Abbreviated name of the Flexible PIC Concentrator (FPC) On PTX10016, an FPC is equivalent to a line card.	n is a value in the range of 0–15 for the PTX10016. The value corresponds to the line-card slot number in which the line card is installed.	Line card (The router does not have actual FPCs—the line cards are the FPC equivalents on the router.)	Understanding Interface Naming Conventions
PIC (n)	-	Value of n is always 0.	-	Understanding Interface Naming Conventions

Table 4: CLI Equivalents of Terms Used in Documentation for PTX10016 Routers (*Continued*)

Hardware Item (CLI)	Description (CLI)	Value (CLI)	Item In Documentation	Additional Information
PSM (<i>n</i>)	<p>Abbreviation for power supply module</p> <p>One of the following:</p> <ul style="list-style-type: none"> • JNP10K-PWR-AC • JNP10K-PWR-AC2 • JNP10K-PWR-DC • JNP10K-PWR-DC2 	<p><i>n</i> is a value in the range of 0–5. The value corresponds to the power-supply slot number.</p>	AC, DC, HVAC, or HVDC power supply	<p>One of the following:</p> <ul style="list-style-type: none"> • "JNP10K-PWR-AC Power Supply" on page 47 • "JNP10K-PWR-AC2 Power Supply" on page 50 • "JNP10K-PWR-DC Power Supply" on page 53 • "JNP10K-PWR-DC2 Power Supply" on page 55
RE	RE (<i>n</i>)	<p><i>n</i> is a value in the range of 0–1.</p> <p>Multiple line items appear in the CLI if more than one RCB is installed in the chassis.</p>	RCB	<p>"PTX10016 Routing and Control Board Description" on page 69</p>

Table 4: CLI Equivalents of Terms Used in Documentation for PTX10016 Routers (*Continued*)

Hardware Item (CLI)	Description (CLI)	Value (CLI)	Item In Documentation	Additional Information
SIB (<i>n</i>)	<p>This field indicates:</p> <ul style="list-style-type: none"> • State of the fabric plane: <ul style="list-style-type: none"> • Active • Spare • Check state • Status of the Packet Forwarding Engine in each fabric plane: <ul style="list-style-type: none"> • Links OK • Error 	<i>n</i> is a value in the range of 0–5.	Fabric plane	<i>show chassis fabric sibs</i>
Xcvr (<i>n</i>)	Abbreviated name of the transceiver	<i>n</i> is a value equivalent to the number of the port in which the transceiver is installed.	Optical transceivers	"PTX10016 Optical Transceiver and Cable Support" on page 188

RELATED DOCUMENTATION

[PTX10016 Cooling System | 30](#)

[Perform the Initial Configuration for the PTX10016 Router | 232](#)

[PTX10016 Routing and Control Board Description | 69](#)

[PTX10016 Power System | 46](#)

[PTX10016 Switch Interface Board Description | 78](#)

PTX10016 Chassis

IN THIS SECTION

- [PTX10016 Field-Replaceable Units | 22](#)
- [PTX10016 Status Panel | 24](#)
- [PTX10016 Optional Equipment | 28](#)

The PTX10016 chassis houses the hardware components. The chassis components include the fan trays, fan tray controllers, power supplies, Routing and Control Boards (RCBs), line cards, optional cable management system, and the status panel.

PTX10016 Field-Replaceable Units

Field-replaceable units (FRUs) are router components that you can replace at your site. The router uses the following types of FRUs:

- Hot-insertable and hot-removable—You can remove and replace these components without powering off the router or disrupting the routing function.
- Hot-pluggable—You can remove and replace these components without powering off the router, but the routing function is interrupted until you replace the component.

[Table 5 on page 23](#) lists the FRUs and their types for the PTX10016 routers.

Table 5: FRUs in an PTX10016 Router

FRU	Type
Power supplies	Hot-insertable and hot-removable.
Fan trays	Hot-insertable and hot-removable.
Fan tray controllers	Hot-insertable and hot-removable.
Routing and Control Boards (RCBs)	<p>Redundant configuration:</p> <ul style="list-style-type: none"> • Primary RCB is hot-pluggable. • Backup RCB is hot-insertable and hot-removable. <p>Base configuration:</p> <ul style="list-style-type: none"> • Removal of the RCB causes the router to shut down. You can install a replacement RCB in the second slot. The system restarts to elect a primary RCB and a backup RCB. If necessary, you can switch the primary and backup RCBs using the <code>request chassis routing-engine master switch</code> command. <p>See "PTX10016 Components and Configurations" on page 15.</p>
Switch Interface Boards (SIBs)	<p>SIBs are hot-insertable and hot-removable. We recommend that you take SIBs offline before removing them to avoid traffic loss while the router fabric is being reconfigured. Use the following command:</p> <pre>user@router> request chassis sib slot <i>slot-number</i> offline</pre>
Line cards	<p>Hot-insertable. We recommend that you take line cards offline before removing them. Use the following command:</p> <pre>user@router> request chassis fpc-slot <i>slot-number</i> offline</pre>

Table 5: FRUs in an PTX10016 Router (Continued)

FRU	Type
Optical transceivers See " PTX10016 Optical Transceiver and Cable Support " on page 188 for how to find detailed specifications and the Junos OS release in which the transceivers were introduced.	Hot-insertable and hot-removable.

NOTE: Line cards are not part of the base or redundant configuration. You must order them separately.

NOTE: If you have a Juniper Care service contract, register any addition, change, or upgrade of hardware components at <https://www.juniper.net/customers/support/tools/updateinstallbase/>. Failure to do so can result in significant delays if you need replacement parts. This note does not apply if you replace an existing component with the same type of component.

PTX10016 Status Panel

The status panel of the PTX10016 has two purposes:

- Shows the overall status of the chassis
- Indicates the type of power bus internal to the chassis

Some chassis ship with an enhanced power bus to future-proof the chassis for potential power growth.

The status panel indicates the chassis status through a set of five bicolor LEDs. See [Figure 13 on page 25](#) for a chassis status panel with the standard power bus.

Figure 13: Status Panel on Chassis with the Standard Power Bus

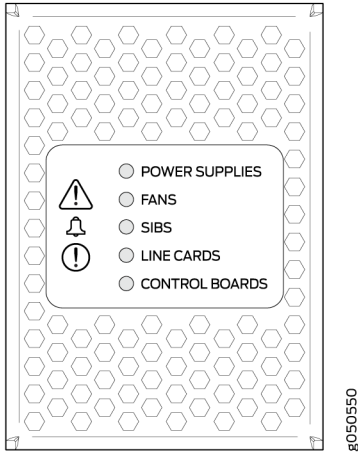

Other chassis also have the same set of five bicolor LEDs, but also have an azure blue line to indicate the presence of the enhanced power bus (see [Figure 14 on page 25](#)).

Figure 14: Status Panel on Chassis with the Enhanced Power Bus

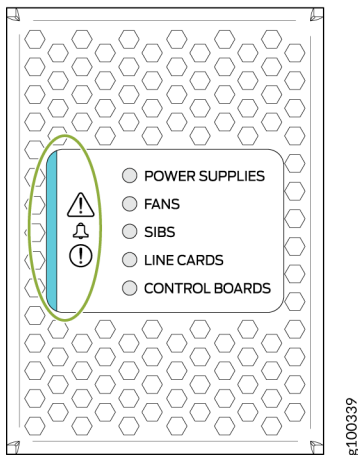

[Table 6 on page 26](#) describes the status panel LEDs.

Table 6: Status Panel LEDs in a PTX10016

Name	Color	State	Description
! Minor alarm (Triangle warning symbol)	Yellow	Off	No minor alarms are active.
		On steadily	A minor alarm is active.
! Major alarm (Circle warning symbol)	Red	Off	No major alarms are active.
		On steadily	A major alarm is active.
POWER SUPPLIES	Green	On steadily	All of the power supplies are online and operating normally.
	Yellow	Blinking	One or more of the power supplies has an error.
	None	Off	None of the power supplies is receiving power.
FANS	Green	On steadily	The fans and the fan tray controllers are online and operating normally.
	Yellow	Blinking	There is an error in a fan or in one of the fan tray controllers.
	None	Off	The fan tray controllers and fan trays are not receiving power.
SIBS	Green	On steadily	At least one installed Switch Interface Board (SIB) is online.
	Yellow	Blinking	There is a hardware error in one or more SIBs.

Table 6: Status Panel LEDs in a PTX10016 (Continued)

Name	Color	State	Description
	None	Off	All the SIBs are offline.
LINE CARDS	Green	On steadily	At least one installed line card is online.
	Yellow	Blinking	There is a hardware error in one or more line cards.
	None	Off	All the line cards are offline.
CONTROL BOARDS	Green	On steadily	All installed Routing and Control Boards (RCBs) are online.
	Yellow	Blinking	One or more RCBs have an error condition.
	None	Off	The installed RCBs are offline.

SEE ALSO

[PTX10016 Routing and Control Board Components and Descriptions | 69](#)

[PTX10016 Cooling System and Airflow | 30](#)

[PTX10016 Switch Fabric | 78](#)

PTX10016 Optional Equipment

IN THIS SECTION

- [PTX10016 Cable Management System | 28](#)

The PTX10016 routers supports the cable management system (JLC-CBL-MGMT-KIT) as optional equipment:

PTX10016 Cable Management System

You can use the PTX10016 cable management system (see [Figure 15 on page 28](#)) to route optical cables away from the line-card ports for better airflow through the chassis. Using this optional system also makes it easier to use cable ties or strips to organize the cabling.

Figure 15: PTX10016 Cable Management System

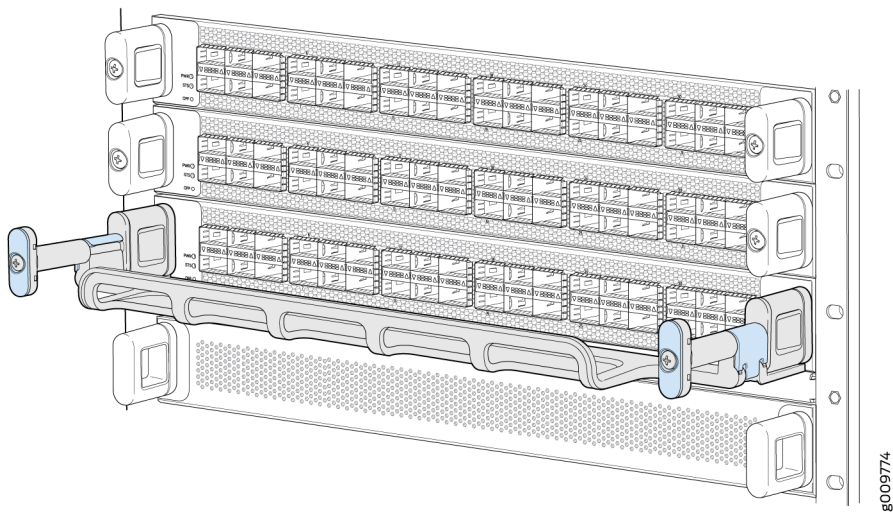

The cable management system comprises a set of handle extensions and a tray that snaps to the extensions (see [Figure 16 on page 29](#)) for an individual line card. You can use the handle extensions

with or without the cable tray. You don't need to remove the handle extensions if you want to remove a line card.

Figure 16: Cable Management Parts

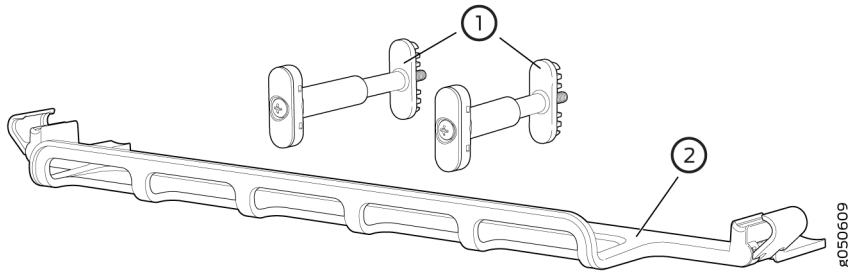

1- Handle extensions

2- Cable tray

Cables are draped across or under the handle extensions and then secured with cable wraps (see [Figure 17 on page 29](#)).

Figure 17: Two Cable Management Systems Installed

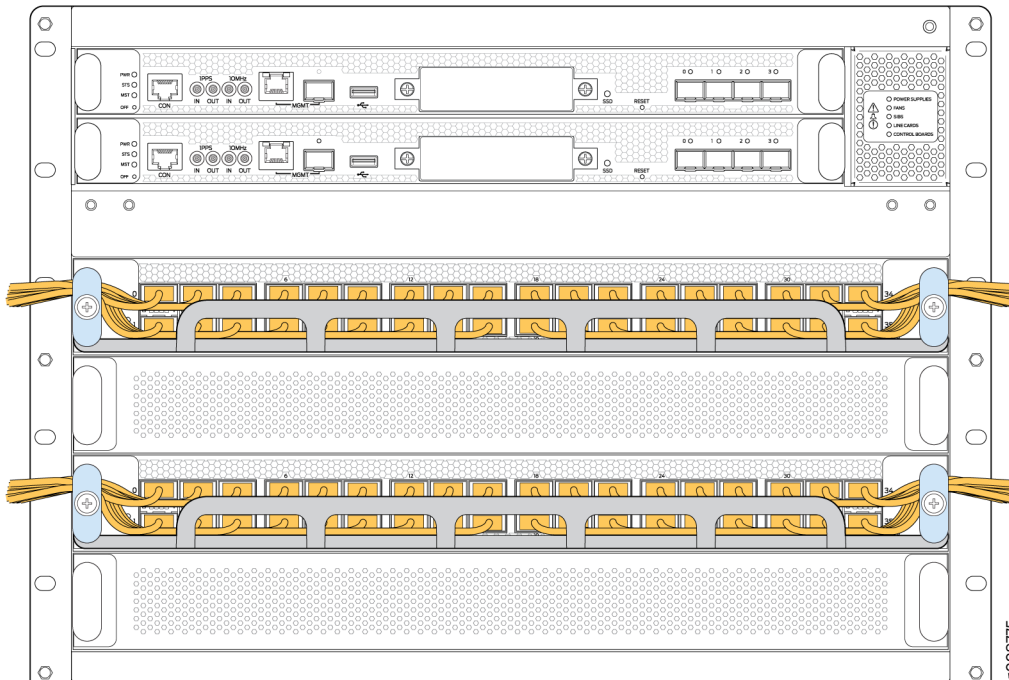

SEE ALSO[Install the PTX10016 Cable Management System | 318](#)[PTX10016 Line Card Components and Descriptions | 83](#)

PTX10016 Cooling System

IN THIS SECTION

- [PTX10016 Cooling System and Airflow | 30](#)
- [PTX10016 Fan Tray LEDs and Fan Tray Controller LEDs | 39](#)

The PTX10016 cooling system components work together to keep all components within the acceptable temperature range. If the maximum temperature specification is exceeded and the system cannot be adequately cooled, the Routing and Control Board (RCB) shuts down some or all of the hardware components.

PTX10016 Cooling System and Airflow

IN THIS SECTION

- [Fan Tray | 31](#)
- [Fan Tray Controller | 34](#)
- [Airflow Direction in the PTX10016 | 37](#)

The cooling system in a PTX10016 chassis consists of dual fan trays and dual fan tray controllers.

Two fan tray models and their associated fan tray controllers are available. See [Table 7 on page 33](#).

Fan Tray

All fan trays are hot-insertable and hot-removable field replaceable units (FRUs). Each fan tray contains 21 fans, a non-removable control board, and LEDs.

The two fan trays install vertically, side by side, next to the power supplies on the FRU side of the chassis. Two handles on each front faceplate facilitate handling of the fan tray. See [Figure 18 on page 32](#) and [Figure 19 on page 33](#).

Figure 18: Fan Tray JNP10016-FAN for a PTX10016

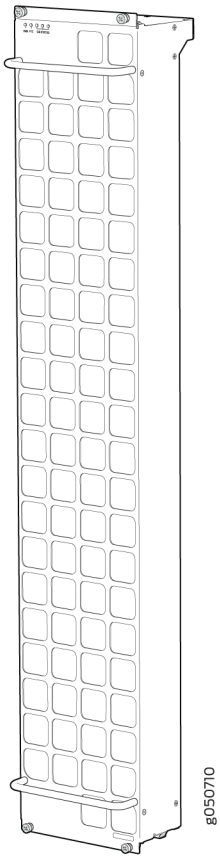
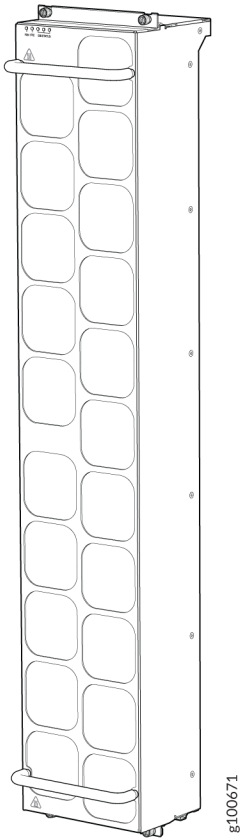

Figure 19: Fan Tray JNP10016-FAN2 for a PTX10016



See [Table 7 on page 33](#) for the physical specifications for the fan trays.

Table 7: Fan Tray Specifications

Specification	JNP10016-FAN	JNP10016-FAN2
Corresponding fan tray controller model	JNP10016-FAN-CTRLR	JNP10016-FTC2
Number of fans per fan tray	21	21
Number of fans per chassis	42	42
Volume flow at 100%	130.67 CFM per fan or 2,744.07 CFM per fan tray	163 CFM per fan or 3,423 CFM per fan tray

Table 7: Fan Tray Specifications (Continued)

Specification	JNP10016-FAN	JNP10016-FAN2
Introduced in Junos OS Release	15.1X53-D30	19.2R1-S1
Height	36.6 in. (92.97 cm)	36.5 in. (92.97 cm)
Width	6.6 in. (16.8 cm)	6.6 in. (16.8 cm)
Depth	4.0 in. (10.2 cm) without handles, 5.2 in. (13.2 cm) with handles	5.5 in. (13.97 cm) without handles, 6.7 in. (17.01 cm)
Weight	19.8 lb (8.98 kg)	33.8 lb (15.33 kg)

Only remove one fan tray when replacing an existing fan tray while the router is running. The router continues to operate for a limited time with a single operating fan tray without triggering a thermal alarm.



CAUTION: To avoid a thermal alarm, do not remove both fan trays while the router is operating.



CAUTION: The chassis will shut down if a thermal alarm is raised for more than three minutes.

The internal fan Control Board in each fan tray contains the LEDs for the associated fan tray controllers and the LEDs for the three SIBs directly behind the fan tray.

Fan Tray Controller

The two fan tray controllers provide the control logic and power to hot-insert and hot-remove a fan tray. The fans in each fan tray are numbered 0 through 20.

The system continually monitors the temperature of critical parts across the chassis and adjusts the chassis fan speed according to the temperature.

There are two fan tray controller models:

- JNP10016-FAN-CTRL—Supports model JNP10016-FAN; see [Figure 20 on page 35](#).

Figure 20: Fan Tray Controller JNP10016-FAN-CTRL

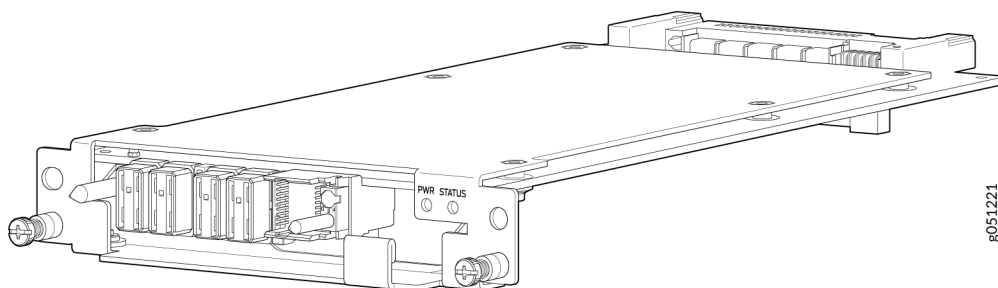

- JNP10016-FTC2—Supports model JNP10016-FAN2; see [Figure 21 on page 35](#).

Figure 21: Fan Controller JNP10016-FTC2

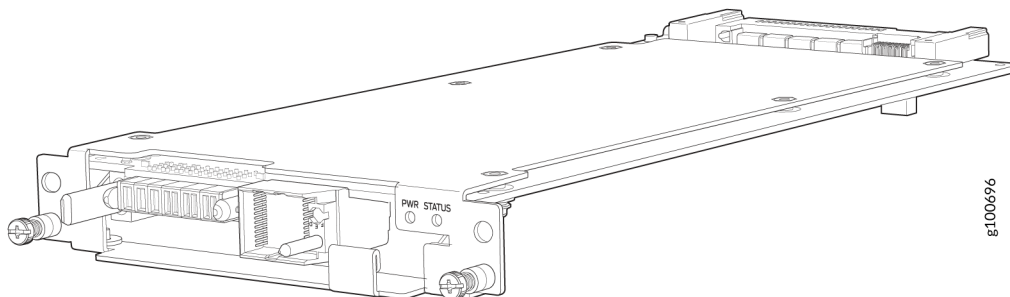

Software controls the fan speed. Under normal operating conditions, the fans in the fan tray run at less than full speed. If one fan tray controller fails or appears missing (such as when a SIB is being replaced) the other fan tray controller sets the fans to full speed. This allows the router to continue to operate normally as long as the remaining fans cool the chassis sufficiently. Use the `show chassis fan` command to see the status of individual fans and fan speed. For example:

```
user@device> show chassis fan
  Item                Status  RPM    Measurement
  Fan Tray 0 Fan 0    OK      4500   Spinning at normal speed
  Fan Tray 0 Fan 1    OK      4650   Spinning at normal speed
  Fan Tray 0 Fan 2    OK      4650   Spinning at normal speed
  Fan Tray 0 Fan 3    OK      4800   Spinning at normal speed
```

```

Fan Tray 0 Fan 4      OK      4650   Spinning at normal speed
Fan Tray 0 Fan 5      OK      4650   Spinning at normal speed
Fan Tray 0 Fan 6      OK      4650   Spinning at normal speed
Fan Tray 0 Fan 7      OK      4500   Spinning at normal speed
Fan Tray 0 Fan 8      OK      4500   Spinning at normal speed
Fan Tray 0 Fan 9      OK      4650   Spinning at normal speed
Fan Tray 0 Fan 10     OK      4650   Spinning at normal speed
Fan Tray 0 Fan 11     OK      4500   Spinning at normal speed
Fan Tray 0 Fan 12     OK      4500   Spinning at normal speed
Fan Tray 0 Fan 13     OK      4500   Spinning at normal speed
Fan Tray 0 Fan 14     OK      4650   Spinning at normal speed
Fan Tray 0 Fan 15     OK      4350   Spinning at normal speed
Fan Tray 0 Fan 16     OK      4500   Spinning at normal speed
Fan Tray 0 Fan 17     OK      4500   Spinning at normal speed
Fan Tray 0 Fan 18     OK      4350   Spinning at normal speed
Fan Tray 0 Fan 19     OK      4500   Spinning at normal speed
Fan Tray 0 Fan 20     OK      4500   Spinning at normal speed
Fan Tray 1 Fan 0      OK      4500   Spinning at normal speed
Fan Tray 1 Fan 1      OK      4650   Spinning at normal speed
Fan Tray 1 Fan 2      OK      4500   Spinning at normal speed
Fan Tray 1 Fan 3      OK      4500   Spinning at normal speed
Fan Tray 1 Fan 4      OK      4650   Spinning at normal speed
Fan Tray 1 Fan 5      OK      4650   Spinning at normal speed
Fan Tray 1 Fan 6      OK      4650   Spinning at normal speed
Fan Tray 1 Fan 7      OK      4500   Spinning at normal speed
Fan Tray 1 Fan 8      OK      4500   Spinning at normal speed
Fan Tray 1 Fan 9      OK      4650   Spinning at normal speed
Fan Tray 1 Fan 10     OK      4500   Spinning at normal speed
Fan Tray 1 Fan 11     OK      4500   Spinning at normal speed
Fan Tray 1 Fan 12     OK      4500   Spinning at normal speed
Fan Tray 1 Fan 13     OK      4650   Spinning at normal speed
Fan Tray 1 Fan 14     OK      4500   Spinning at normal speed
Fan Tray 1 Fan 15     OK      4650   Spinning at normal speed
Fan Tray 1 Fan 16     OK      4650   Spinning at normal speed
Fan Tray 1 Fan 17     OK      4650   Spinning at normal speed
Fan Tray 1 Fan 18     OK      4650   Spinning at normal speed
Fan Tray 1 Fan 19     OK      4500   Spinning at normal speed
Fan Tray 1 Fan 20     OK      4500   Spinning at normal speed

```

```
user@device>
```

Two fan tray controller models and their associated fan trays are available. All models are hot-insertable and hot-removable. See [Table 8 on page 37](#).

Table 8: Fan Tray Controller Specifications

Specification	JNP10016-FAN-CTRL	JNP10016-FTC2
Corresponding fan tray model	JNP10016-FAN	JNP10016-FAN2
Introduced in Junos OS Release	17.4.R1	19.2R1
Height	1.5 in. (3.81 cm)	1.5 in. (3.81 cm)
Width	6.5 in. (15.24 cm)	6.5 in. (15.24 cm)
Depth	12.4 in. (31.5 cm)	12.4 in. (31.5 cm)
Weight	1.5 lb (0.68 kg)	2.3 lb (1.04 cm)

Airflow Direction in the PTX10016

The air intake to cool the chassis is located on the port (line card) side of the chassis. Air flows into the chassis from the ports in the RCBs and line cards, through the SIBs, and exits from the fan trays and the

power supplies. This airflow is called port-to-FRU cooling or airflow out (AFO). See [Figure 22 on page 38](#).

Figure 22: Airflow Through a PTX10016

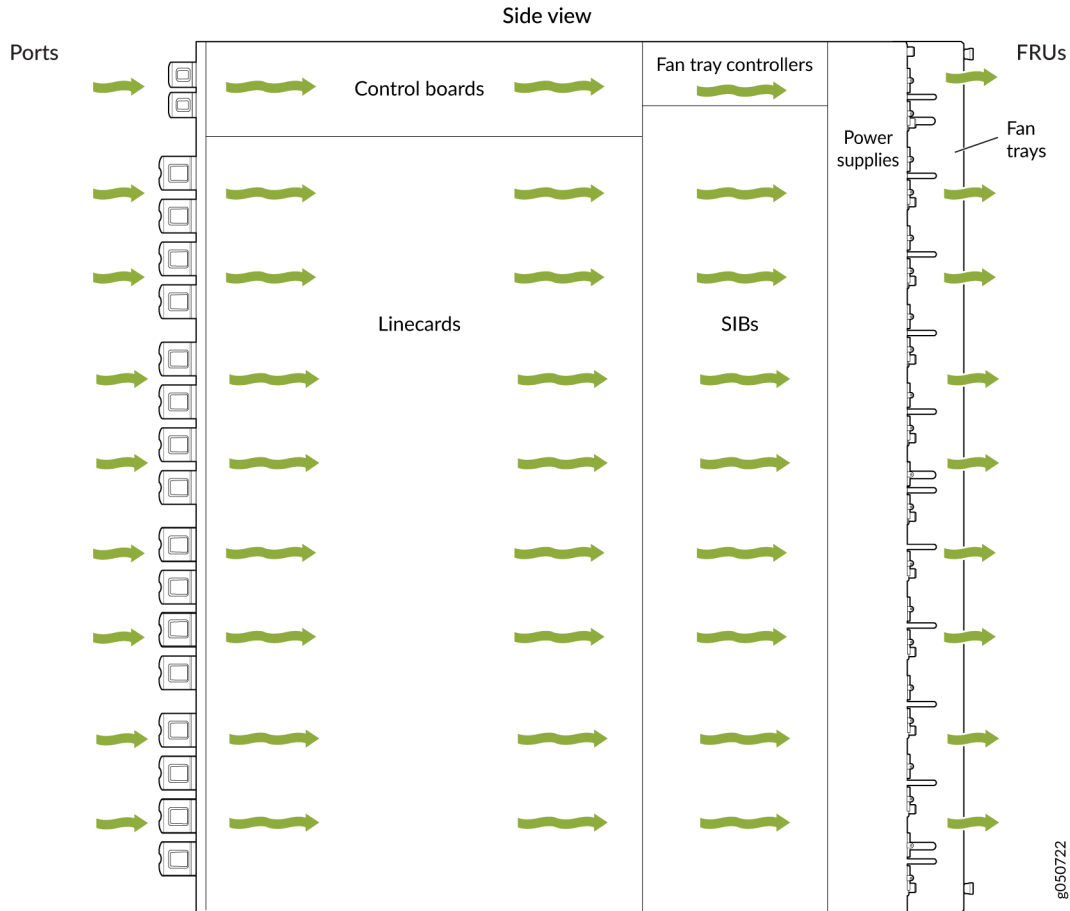

The fan tray continues to operate indefinitely and provides sufficient cooling even when a single fan fails, provided the room temperature is within the operating range. You can check the status of fans by viewing the LEDs on each fan tray. See ["PTX10016 Fan Tray LEDs and Fan Tray Controller LEDs" on page 39](#).

You cannot replace a single fan. If one or more fans fail, you must replace the entire fan tray.

In addition to the fan trays, there is an internal fan in each power supply.

PTX10016 Fan Tray LEDs and Fan Tray Controller LEDs

IN THIS SECTION

- Fan Tray LEDs | 39
- Fan Tray Controller LEDs | 44

Each fan tray has a set of LEDs, and each corresponding fan tray controller also has a set of LEDs.

Fan Tray LEDs

Each fan tray has a set of LEDs that represent the status of the fans in the fan tray, the fan tray controller, and the three Switch Interface Boards (SIBs). The fan tray LEDs are located in the top left corner of each fan tray. [Figure 23 on page 39](#) shows the location of the LEDs on JNP10016-FAN fan trays. See [Figure 24 on page 40](#) for the location of LEDs on the JNP10016-FAN2 fan trays.

Figure 23: Fan Tray JNP10016-FAN LEDs

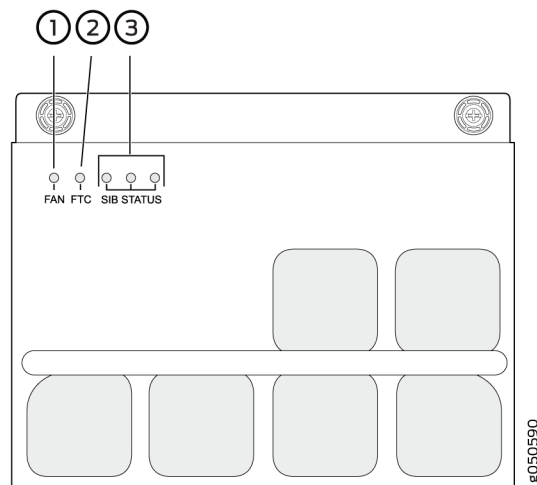

1– Fan status LED

3– SIB status LEDs (SIB 0 through SIB 2 for the left fan tray and SIB 3 through SIB 5 for the right fan tray)

2- Fan tray controller status LED

Figure 24: Fan Tray JNP10016-FAN2 LEDs

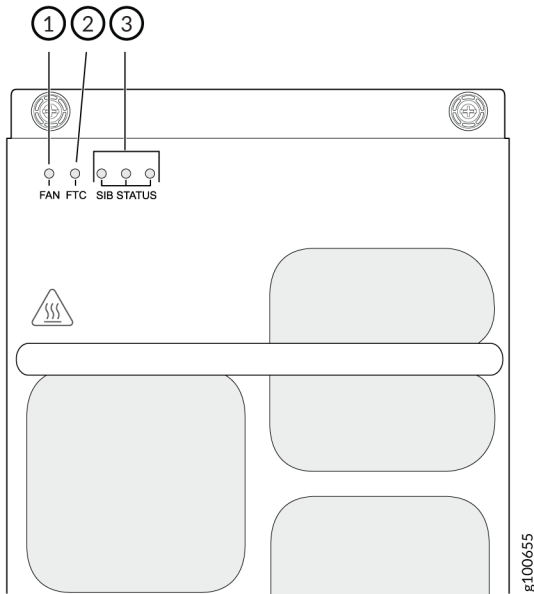

1- Fan status LED

3- SIB status LEDs (SIB 0 through SIB 2 for the left fan tray and SIB 3 through SIB 5 for the right fan tray).

2- Fan tray controller status LED

Table 9 on page 40 describes the functions of the fan tray LEDs.

Table 9: Fan Tray LEDs on a PTX10016 Router

Name	Color	State	Description
FAN (fan status)	Green	On steadily	All fans are operating normally. The system has verified that the fan tray is engaged, that the airflow is in the correct direction, and that all fans are operating correctly.

Table 9: Fan Tray LEDs on a PTX10016 Router *(Continued)*

Name	Color	State	Description
	Yellow	Blinking	An error has been detected in one or more fans in the fan tray. Replace the fan tray as soon as possible. Either the fan has failed or it has become disconnected. To maintain proper airflow through the chassis, leave the fan tray installed in the chassis until you are ready to replace it.
	None	Off	The fan is not receiving power from the fan tray controller.
FTC (fan tray controller status)	Green	On steadily	The fan tray controller is online and is operating normally.
	Yellow	Blinking	An error has been detected in the fan tray controller. Replace the fan tray controller as soon as possible. The fan tray controller is located behind the fan tray above the SIBs. To maintain proper airflow through the chassis, leave the fan tray installed in the chassis until you are ready to replace the fan tray controller.
	None	Off	The fan tray controller is not receiving power.
SIB Status (SIB 0 status)	Green	On steadily	The left-most SIB in the chassis is online.

Table 9: Fan Tray LEDs on a PTX10016 Router *(Continued)*

Name	Color	State	Description
	Yellow	Blinking	An error has been detected in SIB 0. Replace the SIB as soon as possible. The SIB is located behind the left fan tray and is the left-most SIB in the chassis. To maintain proper airflow through the chassis, leave the fan tray installed in the chassis until you are ready to replace the SIB.
	None	Off	The SIB is offline.
SIB Status (SIB 1 status)	Green	On steadily	The center SIB behind the left fan tray is online.
	Yellow	Blinking	An error has been detected in SIB 1. Replace the SIB as soon as possible. The SIB is located behind the left fan tray and is the middle SIB in the group of 3. To maintain proper airflow through the chassis, leave the fan tray installed in the chassis until you are ready to replace the SIB.
	None	Off	The SIB is offline.
SIB Status (SIB 2 status)	Green	On steadily	The right-most SIB behind the left fan tray is online.

Table 9: Fan Tray LEDs on a PTX10016 Router *(Continued)*

Name	Color	State	Description
	Yellow	Blinking	An error has been detected in SIB 2. Replace the SIB as soon as possible. The SIB is located behind the left fan tray and is the right-most SIB in the group of 3. To maintain proper airflow through the chassis, leave the fan tray installed in the chassis until you are ready to replace the SIB.
	None	Off	The SIB is offline.
SIB Status (SIB 3 status)	Green	On steadily	The left-most SIB behind the right fan tray is online.
	Yellow	Blinking	An error has been detected in SIB 3. Replace the SIB as soon as possible. The SIB is located behind the right fan tray and is the left-most SIB in the group of 3. To maintain proper airflow through the chassis, leave the fan tray installed in the chassis until you are ready to replace the SIB.
	None	Off	The SIB is offline.
SIB Status (SIB 4 status)	Green	On steadily	The center SIB behind the right fan tray is online.

Table 9: Fan Tray LEDs on a PTX10016 Router *(Continued)*

Name	Color	State	Description
	Yellow	Blinking	An error has been detected in SIB 4. Replace the SIB as soon as possible. The SIB is located behind the right fan tray and is the middle SIB in the group of 3. To maintain proper airflow through the chassis, leave the fan tray installed in the chassis until you are ready to replace the SIB.
	None	Off	The SIB is offline.
SIB Status (SIB 5 status)	Green	On steadily	The right-most SIB behind the right fan tray is online.
	Yellow	Blinking	An error has been detected in SIB 5. Replace the SIB as soon as possible. The SIB is located behind the right fan tray and is the right-most SIB in the group of 3. To maintain proper airflow through the chassis, leave the fan tray installed in the chassis until you are ready to replace the SIB.
	None	Off	The SIB is offline.

Fan Tray Controller LEDs

All models of fan tray controller have the same LEDs. The fan tray controller LEDs are visible only when the associated fan tray is removed. The fan tray controller LEDs are located on the right of the controller

panel. [Figure 25 on page 45](#) shows the location of the LEDs on the JNP10016-FAN-CTRL or the JNP10016-FTC2 fan tray controller faceplate.

Figure 25: Fan Tray Controller LEDs on a PTX10016

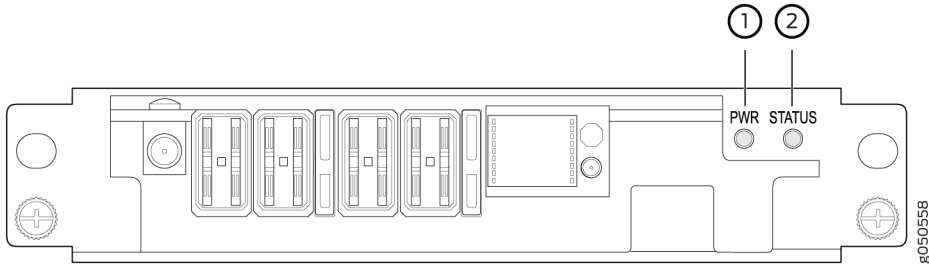

1– Fan tray controller power

2– Fan tray controller status

[Table 10 on page 45](#) describes the functions of the fan tray controller LEDs.

Table 10: Fan Tray Controller LEDs on a PTX10016

Name	Color	State	Description
PWR (fan tray controller power)	Green	On steadily	The fan tray controller has power and is operating normally.
	Yellow	Blinking	A power error has been detected in the fan tray controller. Replace the fan tray controller as soon as possible. To maintain proper airflow through the chassis, leave the fan tray installed in the chassis until you are ready to replace the fan tray controller.
	None	Off	The fan tray controller is not powered on or is not receiving power.
STATUS (fan tray controller status)	Green	On steadily	The fan tray controller is online and is operating normally.

Table 10: Fan Tray Controller LEDs on a PTX10016 (Continued)

Name	Color	State	Description
	Yellow	Blinking	An error has been detected in the fan tray controller. Replace the fan tray controller as soon as possible. To maintain proper airflow through the chassis, leave the fan tray installed in the chassis until you are ready to replace the fan tray controller.
	None	Off	The fan tray controller is not receiving power.

SEE ALSO

[Install a PTX10016 Fan Tray Controller | 251](#)

[Remove a PTX10016 Fan Tray Controller | 254](#)

RELATED DOCUMENTATION

[Install a PTX10016 Fan Tray | 243](#)

[Remove a PTX10016 Fan Tray | 246](#)

PTX10016 Power System

IN THIS SECTION

● [JNP10K-PWR-AC Power Supply | 47](#)

● [JNP10K-PWR-AC2 Power Supply | 50](#)

- JNP10K-PWR-DC Power Supply | 53
- JNP10K-PWR-DC2 Power Supply | 55
- JNP10K-PWR-AC Power Supply LEDs | 58
- JNP10K-PWR-AC2 Power Supply LEDs | 61
- JNP10K-PWR-DC Power Supply LEDs | 64
- JNP10K-PWR-DC2 Power Supply LEDs | 67

PTX10016 routers support AC, DC, high-voltage alternating current (HVAC) and high-voltage direct current (HVDC) by offering the following power supplies:

- JNP10K-PWR-AC
- JNP10K-PWR-AC2
- JNP10K-PWR-DC
- JNP10K-PWR-DC2

You can install up to 10 power supplies in the slots labeled **PEM 0** through **PEM 9** (top to bottom) located in the rear of the chassis.

JNP10K-PWR-AC Power Supply

The JNP10K-PWR-AC power supplies are 2700-W and support 200–240 VAC. The output power is 2700 W.



CAUTION: Do not mix AC and DC power supplies in the same chassis. AC and HVAC can coexist in the same chassis during the hot swap of AC for HVAC. Do not mix AC and HVAC power supplies in a running environment.



WARNING: The router is pluggable type A equipment installed in a restricted-access location. It has a separate protective earthing terminal on the chassis that must be connected to earth ground permanently to ground the chassis adequately and protect the operator from electrical hazards.



CAUTION: Before you begin installing the router, ensure that a licensed electrician has attached an appropriate grounding lug to the grounding cable that you supply. Using a grounding cable with an incorrectly attached lug can damage the router.



CAUTION: You can prevent AC power cables from being exposed to hot air exhaust by always routing the power cables away from the fan trays and power supplies.

The number of power supplies furnished as standard varies by configuration model. For details about different router configurations, see "[PTX10016 Components and Configurations](#)" on page 15.

Each JNP10K-PWR-AC power supply has two independent 16-A rated AC inlets on the faceplate. Although each inlet provides sufficient input power to provide full output, always connect to a dedicated AC power feed to provide redundancy. Only one power feed is operational at a time. The JNP10K-PWR-AC does not share power; all power comes into INP1 (lower receptacle) and only uses INP2 (top receptacle) at fail over.

NOTE: For redundancy, always plug the two power cords from each power supply:

- **INP1** into the public electricity supply
- **INP2** into an alternative or independent power source

Each JNP10K-PWR-AC power supply has a power switch with international markings for on (I) and off (O), a fan, and four LEDs on the faceplate that indicate the status of the power supply. It also has a set

of dual inline package (DIP) switches that enable the source feeds, **INP1** and **INP2**. See [Figure 26 on page 49](#).

Figure 26: JNP10K-PWR-AC Power Supply

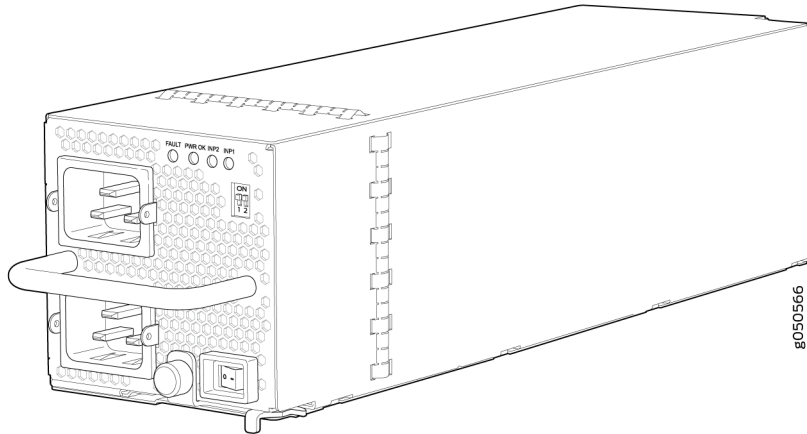

Each JNP10K-PWR-AC power supply comes with two power cord retainers that hold the power cords in place. See [Figure 27 on page 50](#). Each power cord retainer has a clip and an adjustment nut. The ends of the clip hook into the bracket holes on each side of the AC appliance inlet on the faceplate. The adjustment nut holds the power cord in the correct position. For instructions on installing the power cord retainers, see "[Connect AC Power to the PTX10016 Router](#)" on page 227.

NOTE: Route all the AC power supply cords away from the fan trays. Make sure that the power cords do not obstruct the fan trays.

Figure 27: Power Cord Retainer for an JNP10K-PWR-AC Power Supply

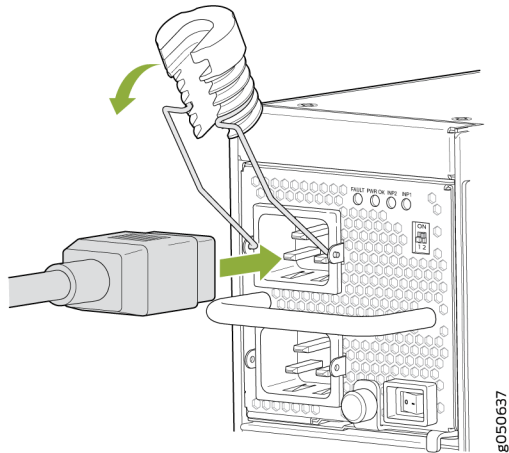

Each power supply connects to the power rail in the router. The power rail distributes the output power produced by the power supplies to different router components. Each power supply provides power to all the components in the router.

Each power supply has its own fan and is cooled by its own internal cooling system. Hot air exhausts from the rear of the chassis.

SEE ALSO

[JNP10K-PWR-AC Power Specifications | 172](#)

[Install a JNP10K-PWR-AC Power Supply | 258](#)

[Remove a JNP10K-PWR-AC Power Supply | 263](#)

JNP10K-PWR-AC2 Power Supply

The JNP10K-PWR-AC2 power supply is a high-capacity model that is designed to support AC, high voltage AC (HVAC), or high voltage DC (HVDC) systems in either a 20-A or a 30-A mode. The power supply feeds AC input and provides DC output 5000 W with a single feed and 5500 W with a dual feed.

For AC systems, the operating input voltage is 180 to 305 VAC and for DC systems, the operating input voltage is 190 to 410 VDC.

The number of power feeds and whether the power supplies provide high output (30-A) or low output (20-A) power is configured using a set of dual inline package (DIP) switches on the faceplate of the power supply. If one power supply in the chassis is set to low power, the power budget for the chassis is reduced to low power, regardless of their DIP switch settings or the output results in CLI. This design safeguards against accidentally setting the power supply to 30-A in a facility that can only provide 20-A and tripping the facility circuit breaker. We recommend that you do not mix DIP switch settings in your system. See [Table 11 on page 52](#) for information about the input and output voltages when you use the DIP switches.

The JNP10K-PWR-AC2 fits into the standard power supply bay but when compared to the JNP10K-PWR-AC, the JNP10K-PWR-AC2 is longer and protrudes from the bay when fully inserted into the chassis. See [Figure 28 on page 51](#) to see the differences in power supply length.

Figure 28: Comparison Between the JNP10K-PWR-AC2 and the JNP10K-PWR-AC Power Supplies

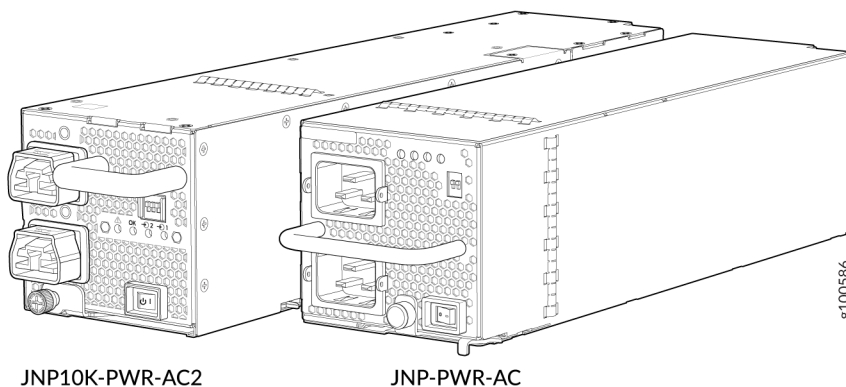

All models of power supplies running in PTX10016 routers have internal fans that contribute to chassis cooling. However, the JNP10K-PWR-AC2 and JNP10K-PWR-DC2 power supplies play a more substantial role in cooling the chassis than the JNP10K-PWR-AC and JNP10K-PWR-DC models. Consequently, all six JNP10K-PWR-AC2 or JNP10K-PWR-DC2 power supplies must be present in a running chassis to have the adequate airflow.



WARNING: Extreme burn danger—Do not handle an HVAC or HVDC power supply running in the chassis without heat protective gloves, such as welder's gloves. The JNP10K-PWR-AC2 can reach temperatures between 158°F to 176°F (70°C to 80°C) under running conditions.



WARNING: The router is pluggable type A equipment installed in a restricted-access location. It has a separate protective earthing terminal on the chassis that must be connected to earth ground permanently to ground the chassis adequately and protect the operator from electrical hazards.



CAUTION: Before you begin installing the router, ensure that a licensed electrician has attached an appropriate grounding lug to the grounding cable that you supply. Using a grounding cable with an incorrectly attached lug can damage the router.



CAUTION: Use a 2-pole circuit breaker rated at 25 A in the building installation and the system, or as per local electrical code.

Table 11: Power Input and Output Voltages for JNP10K-PWR-AC2 Power Supplies

IP 1	IP 2	H/L (High Input 30 A/Low Input 20 A)	Output Power
On	On	On (30 A)	5500 W
On	On	Off (20 A)	3000 W
On	Off	On (30 A)	5000 W
Off	On	On (30 A)	5000 W
On	Off	Off (20 A)	2700 W
Off	On	Off (20 A)	2700 W

- IP1
 - INP1 in the CLI output for Junos OS Evolved Release 20.4R2 or later.
 - INP0 in the CLI output for releases earlier than Junos OS Evolved Release 20.4R2.
- IP2
 - INP2 in the CLI output for Junos OS Evolved Release 20.4R2 or later.

- INP1 in the CLI output for releases earlier than Junos OS Evolved Release 20.4R2.



CAUTION: It is important to connect both input feeds of the JNP10K-PWR-AC2 power supply to AC mains before loading the system with power.

JNP10K-PWR-DC Power Supply

The DC power supply, JNP10K-PWR-DC, is a 2500-W, dual input power supply. The output power is 2500 W.



WARNING: The router is pluggable type A equipment installed in a restricted-access location. It has a separate protective earthing terminal on the chassis that must be connected to earth ground permanently to ground the chassis adequately and protect the operator from electrical hazards.



CAUTION: Before you begin installing the router, ensure that a licensed electrician has attached an appropriate grounding lug to the grounding cable that you supply. Using a grounding cable with an incorrectly attached lug can damage the router.

NOTE: DC power supplies are shipped only in the redundant configuration of PTX10016 routers. For details about different chassis configurations, see "[PTX10016 Components and Configurations](#)" on page 15.

Each JNP10K-PWR-DC power supply has two independent pairs of DC input lugs (**Input 1, RTN, -48V/-60V** and **Input 2, RTN, -48V/-60V**) on the faceplate of the power supply. Each inlet requires a dedicated DC power feed. Although each inlet provides sufficient input power to provide full output, always connect the power supply to a dedicated DC power feed to provide redundancy. Only one power feed is operational at a time.

DC power models employ electronic A-B input selection. Should one power source fail, electronic A-B input selection routes the power supply to the alternate source. The power supply internally balances power between source input A and source input B. The default is to balance 50% to each input.

Each JNP10K-PWR-DC power supply has a power switch with international markings for on (I) and off (O), a built-in fan, and four LEDs on the faceplate that indicate the status of the power supply. See [Figure 29 on page 54](#).

Figure 29: JNP10K-PWR-DC Power Supply

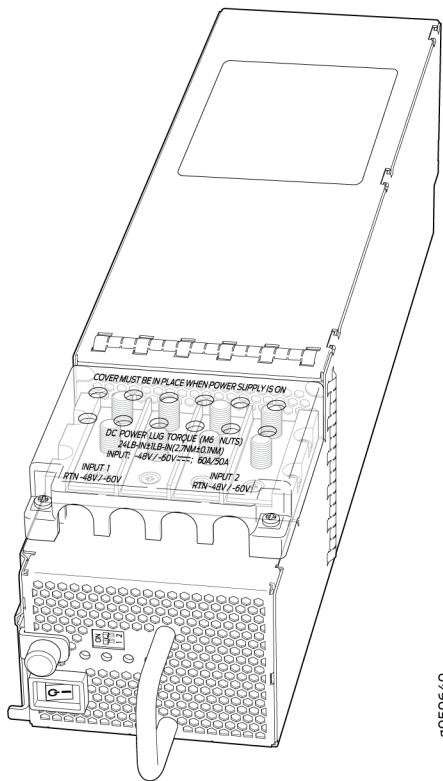

NOTE: The JNP10K-PWR-DC power supply requires a dedicated circuit breaker for each input DC feed. The chosen breaker should be sized to deliver 60 A of input current.

Each power supply connects to the combined power rail in a PTX10016 router. The power rail distributes the output power produced by the power supplies to different router components. Each DC power supply provides power to all the components in the router.

NOTE: Route all the DC power supply cords away from the fan trays. Make sure that the power cords do not obstruct the fan trays.

A JNP10K-PWR-DC power supply can operate with only one input DC feed connected.

Each JNP10K-PWR-DC power supply has its own fan and is cooled by its own internal cooling system. The airflow is from the front of the power supply to the back. Hot air exhausts from the rear of the chassis.

SEE ALSO

[JNP10K-PWR-DC Power Specifications | 184](#)

[Install a JNP10K-PWR-DC Power Supply | 274](#)

[Remove a JNP10K-PWR-DC Power Supply | 283](#)

JNP10K-PWR-DC2 Power Supply

The JNP10K-PWR-DC2 power supply provides two power supplies in a single housing that accepts either 60 A or 80 A using four redundant input power feeds. The two internal power supplies (PS_0 and PS_1) each have redundant input feeds: A0 and/or B0 for PS0 and A1 and/or B1 for PS1. You configure the input using a set of three DIP switches on the power supply faceplate that sets the combined output power for both internal power supplies. The output depends on the settings of these dip switches. See [Table 12 on page 55](#) and [Figure 30 on page 56](#).

Table 12: Power Input and Output Voltages for JNP10K-PWR-DC2 Power Supplies

PS0 (A0 and B0)	PS1 (A1 and B1)	H/L (High Input 80 A/ Low Input 60 A)	Output Power
On	On	On (80 A)	5500 W
On	On	Off (60 A)	4400 W
On	Off	On (80 A)	2750 W
Off	On	On (80 A)	2750 W
On	Off	Off (60 A)	2200 W

Table 12: Power Input and Output Voltages for JNP10K-PWR-DC2 Power Supplies (Continued)

PS0 (A0 and B0)	PS1 (A1 and B1)	H/L (High Input 80 A/ Low Input 60 A)	Output Power
Off	On	Off (60 A)	2200 W

Figure 30: JNP10K-PWR-DC2 Power Supply

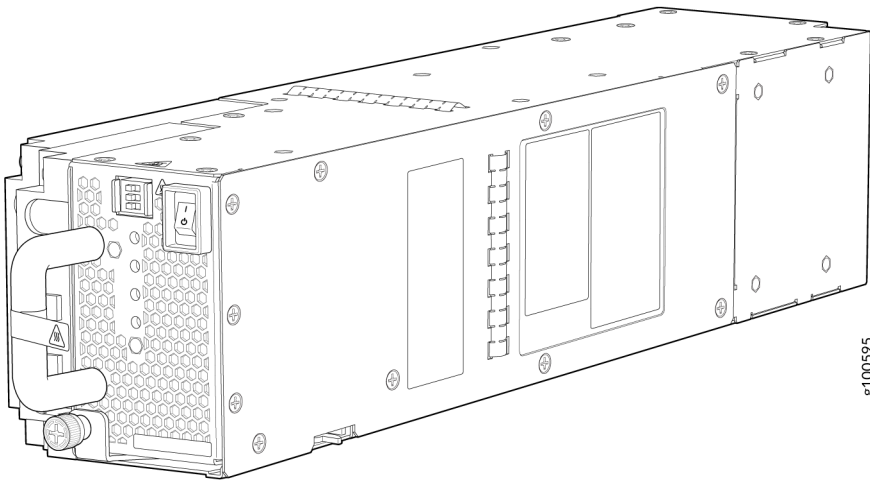

The input capacitance value for the front-end EMI capacitor before the pre-charge circuit in the power supply is 12.2 μF . There is a 15,000 μF bulk capacitor after the pre-charge circuit.

The JNP10K-PWR-DC2 fits into the standard power supply bay but when compared to the JNP10K-PWR-DC, the JNP10K-PWR-DC2 is longer and protrudes from the bay when fully inserted into the chassis. See [Figure 31 on page 57](#) to see the differences in power supply length.

Figure 31: Comparison Between the JNP10K-PWR-DC2 and JNP10K-PWR-DC Power Supplies

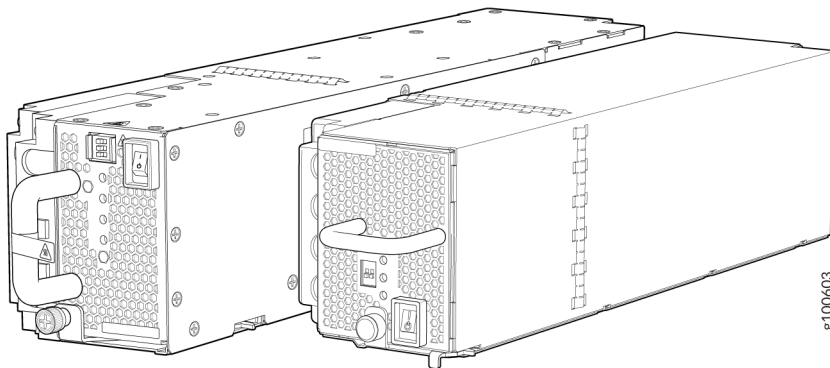

All models of power supplies running in PTX10016 routers have internal fans that contribute to chassis cooling. However, the JNP10K-PWR-AC2 and JNP10K-PWR-DC2 power supplies play a more substantial role in cooling the chassis the JNP10K-PWR-AC and JNP10K-PWR-DC models. Consequently, all six JNP10K-PWR-AC2 or JNP10K-PWR-DC2 power supplies must be present in a running chassis to have the adequate airflow.



CAUTION: Do not mix power supply models in the same chassis in a running environment. JNP10K-PWR-DC and JNP10K-PWR-DC2 can coexist in the same chassis during power supply upgrades.



WARNING: The router is pluggable type A equipment installed in a restricted-access location. It has a separate protective earthing terminal on the chassis that must be connected to earth ground permanently to ground the chassis adequately and protect the operator from electrical hazards.



CAUTION: Before you begin installing the router, ensure that a licensed electrician has attached an appropriate grounding lug to the grounding cable that you supply. Using a grounding cable with an incorrectly attached lug can damage the router.

JNP10K-PWR-AC Power Supply LEDs

The JNP10K-PWR-AC power supply has four LEDs on its faceplate: **INP1**, **INP2**, **PWR OK**, and **FAULT**. These LEDs display information about the status of the power supply. See [Figure 32 on page 58](#).

Figure 32: LEDs on an JNP10K-PWR-AC Power Supply

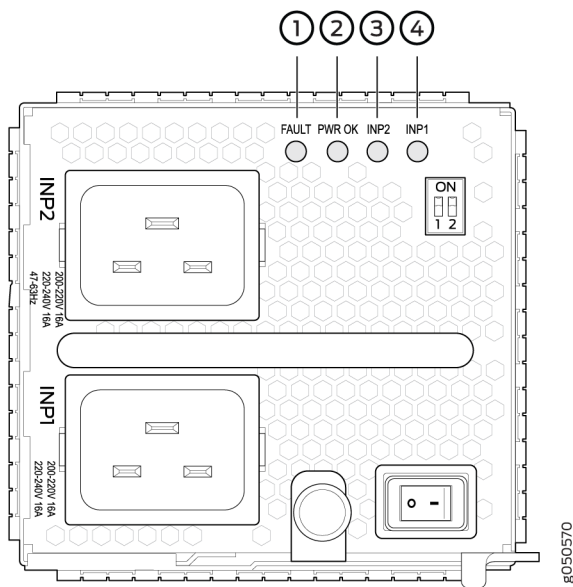

1– **FAULT LED**

2– **PWR OK LED**

3– **INP2 LED**

4– **INP1 LED**

[Table 13 on page 58](#) describes the LEDs on a JNP10K-PWR-AC power supply.

Table 13: LEDs on a JNP10K-PWR-AC Power Supply

LED	Color	State	Description
• INP1	Green	Solid	The power supply is functioning properly.

Table 13: LEDs on a JNP10K-PWR-AC Power Supply (*Continued*)

LED	Color	State	Description
<ul style="list-style-type: none"> • INP1 in the CLI output for Junos OS Evolved Release 20.4R2 or later. • INP0 in the CLI output for releases earlier than Junos OS Evolved Release 20.4R2. • INP2 <ul style="list-style-type: none"> • INP2 in the CLI output for Junos OS Evolved Release 20.4R2 or later. • INP1 in the CLI output for releases earlier than Junos OS Evolved Release 20.4R2. 	Yellow	Blinking	The power supply has detected a power input fault.
	None	Unlit	The power supply is switched off.
PWR OK	Green	Solid	The power supply is functioning properly.
	Yellow	Blinking	The power supply has detected a power output fault.
FAULT	None	Unlit	The power supply is functioning properly.

Table 13: LEDs on a JNP10K-PWR-AC Power Supply (*Continued*)

LED	Color	State	Description
	Red	Solid	The power supply has failed and must be replaced. Or, only one input is powered and the enabled router for the input that is not powered is set to ON . See Install a JNP10K-PWR-AC Power Supply for more information about the enable switches.

NOTE: If the **INP1** or **INP2** LED and the **PWR OK** LED are unlit, the AC power cable is not installed properly or the power supply has failed.

If the **INP1** or **INP2** LED is lit and the **PWR OK** LED is unlit, the AC power supply is not installed properly or the power supply has an internal failure.

JNP10K-PWR-AC2 Power Supply LEDs

The JNP10K-PWR-AC2 power supply has four LEDs on its faceplate: **!**, **OK**, **2**, and **1**. These LEDs display information about the status of the power supply. See [Figure 33 on page 61](#).

Figure 33: LEDs on a JNP10K-PWR-AC2 HVAC /HVDC Power Supply

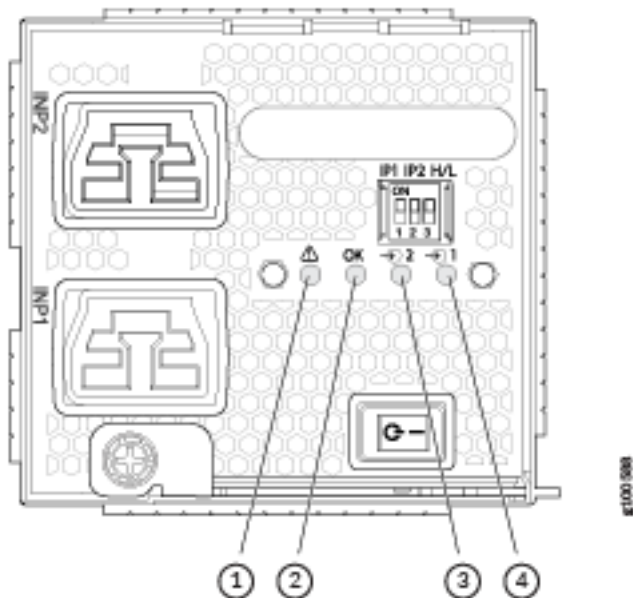

1- ! Fault

2- OK Power OK

3- 2 INP2-Source input 1

4- 1 INP1-Source input 0

NOTE: Physical markings on the power supply are **1** and **2**. These markings correspond to INP0 and INP1 in the `show chassis power output` (see [Table 14 on page 62](#) and ["No Link Title" on page 61](#)).

show chassis power

```
user@chassis> show chassis power
Chassis Power      Voltage(V)   Power(W)

Total Input Power                5592
  PSM 0
    PS0                51       960
```

A0	52		
B0	51		
PS1	51	960	
A1	51		
B1	52		
Output	12.53	1774.98	(80A at 12V)
PSM 1			
PS0	51	888	
A0	52		
B0	52		
PS1	0	0	
Output	12.49	879.22	(80A at 12V)

Table 14: Physical Markings on Chassis Versus show chassis power Command

Physical Marking on JNP10K-PWR-AC2	show chassis power Command
INP1	PS0
INP2	PS1

Table 15 on page 62 describes the LEDs on a JNP10K-PWR-AC2 power supply.

Table 15: Interpreting JNP10K-PWR-AC2 LEDs

LED	Color	State	Description
1	Yellow	Blinking	The input voltage is present, but a fault is detected.
	Green	Solid	The power supply is functioning properly.
	Unlit	Off	The power supply is switched off; voltage is zero.

Table 15: Interpreting JNP10K-PWR-AC2 LEDs (Continued)

LED	Color	State	Description
2 <ul style="list-style-type: none"> INP2 in the CLI output for Junos OS Evolved Release 20.4R2 or later. INP1 in the CLI output for releases earlier than Junos OS Evolved Release 20.4R2. 	Yellow	Blinking	The input voltage is present, but a fault is detected.
	Green	Solid	The power supply is functioning properly.
	Unlit	Off	The power supply is switched off; voltage is zero.
OK (Power OK)	Green	Solid	The power supply is functioning properly.
	Yellow	Blinking	The power supply output has detected a fault.
! (Fault)	Red	Solid	The power supply has failed and must be replaced.
	Unlit	Off	The power supply is functioning normally.

JNP10K-PWR-DC Power Supply LEDs

The JNP10K-PWR-DC power supply has four LEDs on its faceplate: **INP1**, **INP2**, **PWR OK**, and **FAULT**. These LEDs display information about the status of the power supply. See [Figure 34 on page 64](#).

Figure 34: LEDs on a JNP10K-PWR-DC Power Supply

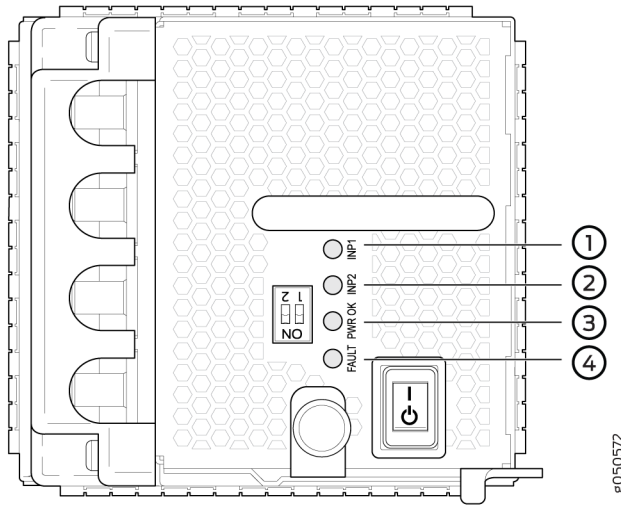

1– **INP1** LED

3– **PWR OK** LED

2– **INP2** LED

4– **FAULT** LED

NOTE: Physical markings on the power supply are **INP1** and **INP2**. These markings correspond to PS0 and PS1 in the show chassis power output (see [Table 16 on page 64](#)).

Table 16: Physical Markings on Chassis Versus show chassis power Command

Physical Marking on JNP10K-PWR-DC2	show chassis power Command
INP1	PS0
INP2	PS1

[Table 17 on page 65](#) describes the LEDs on the JNP10K-PWR-DC power supply.

Table 17: LEDs on a JNP10K-PWR-DC Power Supply

LED	Color	State	Description
<ul style="list-style-type: none"> • INP1 <ul style="list-style-type: none"> • INP1 in the CLI output for Junos OS Evolved Release 20.4R2 or later. • INP0 in the CLI output for releases earlier than Junos OS Evolved Release 20.4R2. 	Yellow	Blinking	Indicates that the DC power input voltage is not within normal operating range.
	Green	Solid	DC power is within operating range (-40 VDC to -72 VDC).
	Unlit	Off	The power supply is switched off.
<ul style="list-style-type: none"> • INP2 <ul style="list-style-type: none"> • INP2 in the CLI output for Junos OS Evolved Release 20.4R2 or later. • INP1 in the CLI output for releases earlier than Junos OS Evolved Release 20.4R2. 			
PWR OK	Green	Solid	DC power output is within normal operating range.
	Yellow	Blinking	The output is out of the limits.
FAULT	Red	Solid	Power supply has failed and must be replaced.

Table 17: LEDs on a JNP10K-PWR-DC Power Supply (Continued)

LED	Color	State	Description
	Unlit	Off	Power supply is functioning normally. Or, only one input is powered and the enable switch for the input that is not powered is set to ON . See Install a JNP10K-PWR-DC Power Supply for more information on the enable switches.

NOTE: If the **INP1** or **INP2** and the **PWR OK** LED are unlit, the power cables are not installed properly or the power supply has failed.

If the **INP1** or **INP2** LED is lit green and the **PWR OK** LED is unlit, the power supply is not installed properly or the power supply has an internal failure.

If the **FAULT** LED is blinking, add a power supply to balance the power demand and supply.

JNP10K-PWR-DC2 Power Supply LEDs

A JNP10K-PWR-DC2 power supply has four LEDs on its faceplate: **1**, **2**, **OK**, and the symbol for fault, **!**. These LEDs display information about the status of the power supply. See [Figure 35 on page 67](#).

Figure 35: LEDs on a JNP10K-PWR-DC2 Power Supply

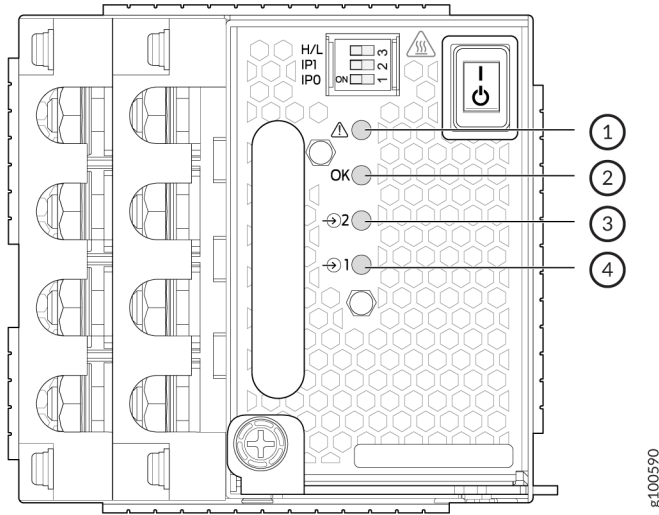

1– **!** Fault

2– **OK** Power OK

3– **2** Power source input 1

4– **1** Power source input 0

[Table 18 on page 67](#) describes the LEDs on a JNP10K-PWR-DC2 power supply.

Table 18: LEDs on a JNP10K-PWR-DC2 Power Supply

LED	Color	State	Description
1 (PS0 in CLI output) or 2 (PS1 in CLI output)	Green	Solid	The DC power is within operating range (–40 VDC to –72 VDC).
	Yellow	Blinking	The DC power input voltage is not within normal operating range.
	Unlit	Off	The power supply is switched off.

Table 18: LEDs on a JNP10K-PWR-DC2 Power Supply (Continued)

LED	Color	State	Description
OK (Power OK)	Green	Solid	The DC power output is within normal operating range.
	Yellow	Blinking	The power supply output is out of the power limits.
! (Fault)	Red	Solid	The power supply has failed and must be replaced.
	Unlit	Off	The power supply is functioning normally. Or, only one input is powered and the enable switch for the input that is not powered is set to ON . See or " Connect DC Power to a PTX10016 Router " on page 228 for more information about the enable switches.

NOTE: If the **1** or **2** and the **OK** LED are unlit, the power cables are not installed properly or the power supply has failed.

If the **1** or **2** LED is lit green and the **OK** LED is unlit, the power supply is not installed properly or the power supply has an internal failure.

If the **!** LED is blinking, add a power supply to balance the power demand and supply.

RELATED DOCUMENTATION

[Power Requirements for PTX10016 Components](#) | 161

[Connect DC Power to a PTX10016 Router](#) | 228

PTX10016 Routing and Control Board Components and Descriptions

IN THIS SECTION

- [PTX10016 Routing and Control Board Description | 69](#)
- [PTX10016 Routing and Control Board LEDs | 72](#)

The Routing and Control Board (RCB) is an integrated board and a single FRU that provides Routing Engine and Control Board (CB) functionality. The Routing Engine performs all route-processing functions, whereas the CB performs chassis control and management plane functionality. The RCB provides control plane functions. You can install one or two RCBs on the router. Each RCB functions as a unit.

PTX10016 Routing and Control Board Description

IN THIS SECTION

- [Routing and Control Board Functions | 70](#)
- [Routing and Control Board Components | 71](#)

The PTX10016 Routing and Control Board (RCB) is responsible for system management in a PTX10016 router (see [Figure 36 on page 70](#)). The chassis can run with one or two RCBs. We ship the base configurations with one RCB; and you can expand the configuration with a second RCB for a fully-redundant system. When two RCBs are installed, one functions as the primary RCB and the second as a backup. If the primary RCB is removed, the backup RCB becomes the primary if GRES is configured.

PTX10016 routers support the following Routing Engines:

- JNP10K-RE0
- JNP10K-RE1

- JNP10K-RE1-LT
- JNP10K-RE1-128G

Figure 36: JNP10K-RE0

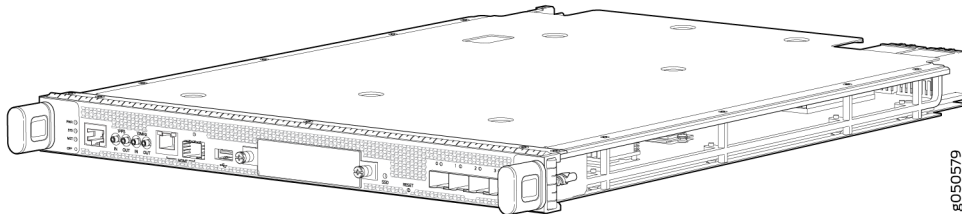
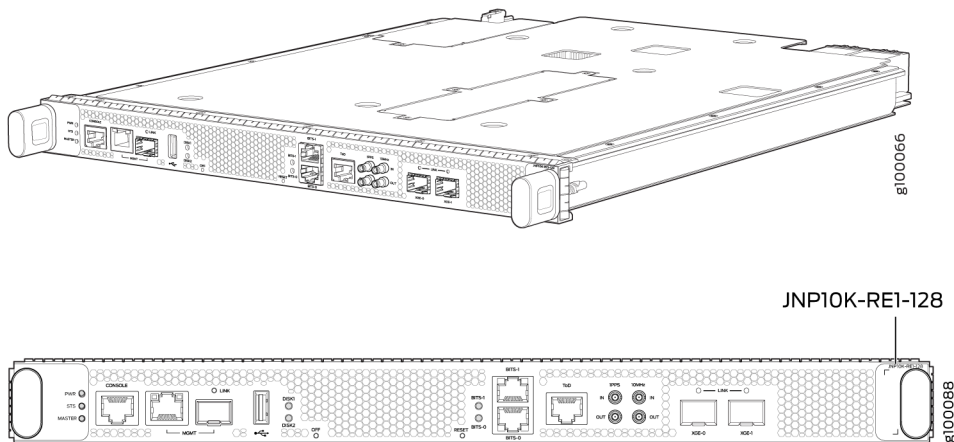

Figure 37: JNP10K-RE1, JNP10K-RE1-E, JNP10K-RE1-128G, and JNP10K-RE1-E128



Routing and Control Board Functions

The Routing and Control Board integrates the control plane and Routing Engine functions into a single management unit. Each RCB provides all the functions needed to manage the operation of the modular chassis:

- System control functions such as environmental monitoring
- Routing Layer 2 and Layer 3 protocols
- Communication to all components such as line cards, Switch Interface Boards (SIBs), and power and cooling
- Transparent clocking

- Alarm and logging functions

Routing and Control Board Components

Each RCB consists of the following internal components:

- Quad-core 2.5-GHz CPU
- 32 GB SDRAM
- SATA SSD

Other standard features are shown in [Figure 38 on page 71](#).

Figure 38: Routing and Control Board Faceplate (JNP10K-RE0)

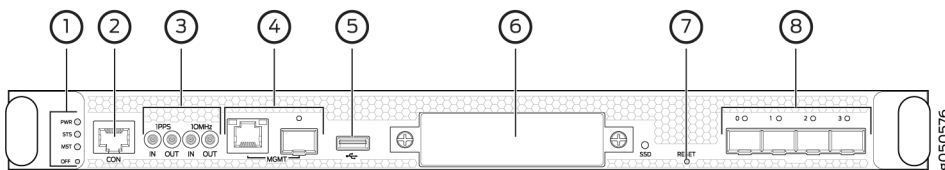

1– RCB status LEDs	5– USB 2.0 port
2– Console (CON) port	6– Secondary 50-GB SATA SSD slot
3– PTP-capable connections: SMB In, SMB Out, 10 MHz In, 10 MHz Out	7– Reset (RESET) button
4– Ethernet management (MGMT) ports: RJ-45 port for 10/100/1000 BASE-T (em0) and small-form factor pluggable (SFP) for port fiber (em1). If both copper and fiber cables are installed, the RJ-45 is the default.	8– Four SFP+ ports (reserved for future use)

NOTE: You can use either management interface, em0 or em1 when the RCB is running as the primary RE. Use only em1 when the RCB is running as the backup RE.

Figure 39: Routing and Control Board Faceplate (JNP10K-RE1 and JNP10K-RE1-E,)

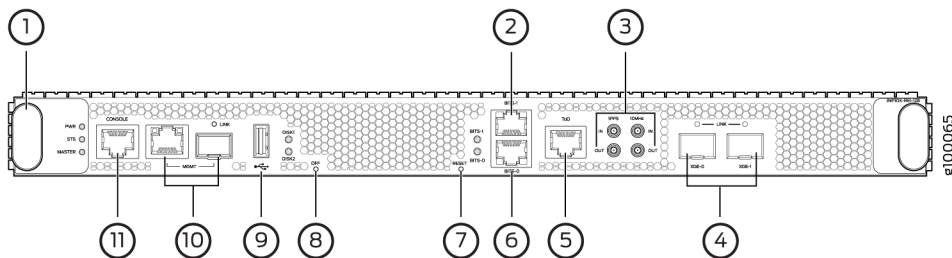

1– Handles	7– Reset button
2– BITS-1 clock port	8– Online/Offline button
3– GPS clock ports (1PPS and 10MHz)	9– USB port
4– XGE-0 and XGE-1 not used (reserved ports)	10– Management (MGMT) ports
5– ToD —Time-of-day (TOD) port	11– Console (CONSOLE) port
6– BITS-0 clock port	

SEE ALSO

[How to Hold Line Cards and RCBs | 300](#)

[Install a PTX10016 Routing and Control Board | 238](#)

PTX10016 Routing and Control Board LEDs

IN THIS SECTION

- [Routing and Control Board Status Panel LEDs | 74](#)
- [PTX10016 Management Port LEDs | 75](#)
- [SATA SSD LEDs | 76](#)

- Clock LEDs (JNP10K-RE1, JNP10K-RE1-LT, and JNP10K-RE1-128) | 77

The PTX10016 Routing and Control Boards (RCBs) have various types of LED indicators (see [Figure 40 on page 73](#)).

Figure 40: PTX10016 Routing and Control Board (JNP10K-RE0) LEDs

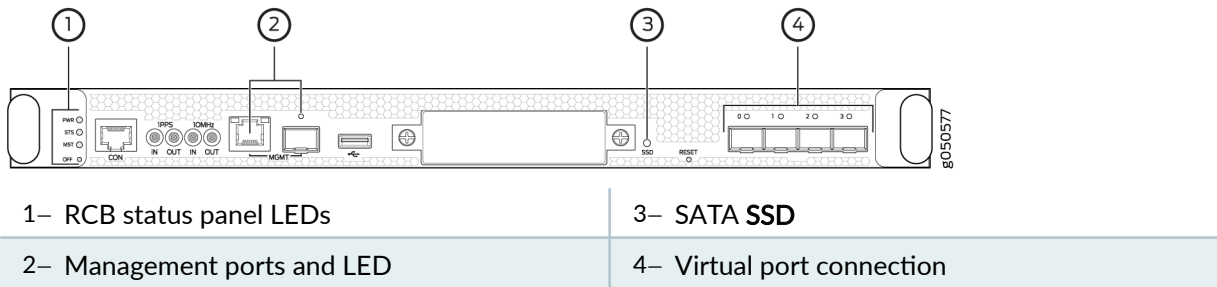
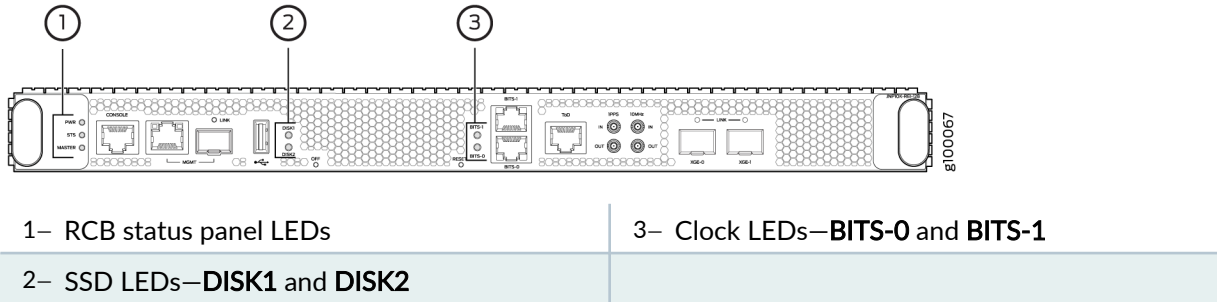

Figure 41: PTX10016 Routing and Control Board (JNP10K-RE1 and JNP10K-RE1-E) LEDs



Routing and Control Board Status Panel LEDs

The RCB status panel LEDs indicate the state of the RCB (see [Figure 42 on page 74](#)).

Figure 42: Routing and Control Board Status Panel LEDs and Button

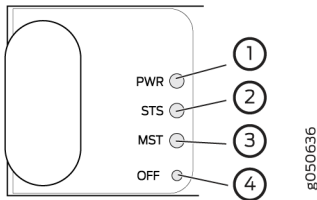

1– Power (**PWR**) LED

3– Primary (**MST**) LED

2– Status (**STS**) LED

4– Offline (**OFF**) button

[Table 19 on page 74](#) describes the LEDs on the RCB status panel.

Table 19: Routing and Control Board (JNP10K-RE0 and JNP10K-RE1) Status LEDs

LED	Color	State	Description
PWR (Power)	Green	On steadily	The RCB is receiving adequate power.
	Yellow	Blinking	The RCB has detected an error.
	None	Unlit	The RCB is not powered up.
STS (Status)	Green	On steadily	The RCB is online and functioning correctly.
	Green	Blinking	The beacon feature is enabled.
	Yellow	On steadily	The RCB is booting.
	Yellow	Blinking	The RCB has detected an error.
	None	Unlit	The RCB is not receiving power.

Table 19: Routing and Control Board (JNP10K-RE0 and JNP10K-RE1) Status LEDs (Continued)

LED	Color	State	Description
MST (Primary)	Green	On steadily	The RCB is the primary RCB.
	None	Unlit	The RCB is the backup RCB.

PTX10016 Management Port LEDs

The two management ports on the RCB of a PTX10016 router have LEDs that indicate link status and link activity. These two ports, located on the RCB panel between the clocking connections and the USB port, are both labeled **MGMT**. The left management port (RJ-45) is for 10/100/1000 BASE-T connections, and the right port (SFP) is for 10/100/1000 BASE-T and small form-factor pluggable (SFP) 1000 BASE-X connections (see [Figure 43 on page 75](#)). The copper (RJ-45) port has separate LEDs for status and activity. The fiber (SFP) port has a combination link and activity LED.

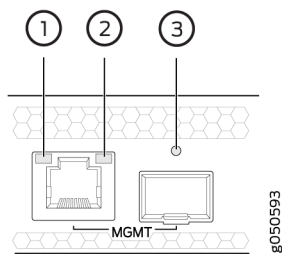
Figure 43: Management Port LEDs on a PTX10016

1– Status LED (RJ-45)	3– Link/activity/status LED (SFP))
2– Activity LED (RJ-45)	

[Table 20 on page 75](#) describes the RJ-45 management port LEDs, and [Table 21 on page 76](#) describes the SFP status LEDs.

Table 20: RJ-45 Management Port LEDs on a PTX10016 Routing and Control Board

LED	Color	State	Description
Port speed	Unlit	Off	The port speed is 10 MB.

Table 20: RJ-45 Management Port LEDs on a PTX10016 Routing and Control Board (Continued)

LED	Color	State	Description
	Green	Blinking	The port speed is 100 MB.
	Green	On steadily	The port speed is 1000 MB.
Link/Activity/Status	Unlit	Off	No link is established, there is a fault, or the link is down.
	Green	On steadily	A link is established.
		Blinking	There is link activity.
	Yellow	Blinking or flickering	The beacon feature is enabled.

Table 21: SFP Management Port LEDs on a PTX10016 Routing and Control Board (JNP10K-RE0 and JNP10K-RE1)

LED	Color	State	Description
Link/Activity/Status	Unlit	Off	No transceiver is present.
	Green	On steadily	A link is established. The interface is up.
	Green	Blinking or flickering	The beacon feature is enabled.
	Yellow	Blinking	An error has occurred.

XGE0 and **XGE1** are not used.

SATA SSD LEDs

The Serial Advanced Technology Attachment (SATA) solid-state drive (SSD) LEDs indicate the status of the secondary drive.

[Table 22 on page 77](#) describes the LEDs for the secondary SATA drive.

Table 22: Routing and Control Board SSD Status LEDs

LED	Color	State	Description
SSD on JNP10K-RE0 DISK1 and DISK2 on JNP10K-RE1	Green	On steadily	A SATA drive is present.
	Green	Blinking	The drive is active.
	Yellow	On steadily	The drive is active.
	Dark	Unlit	A drive is not installed.

Clock LEDs (JNP10K-RE1, JNP10K-RE1-LT, and JNP10K-RE1-128)

The clock LEDs indicate whether clocking is active.

[Table 23 on page 77](#) describes the clock LEDs.

Table 23: Routing and Control Board Clock Status LED

LED	Color	State	Description
Clock LEDs— BITS-0 and BITS-1	Red	Off	Clock is active.
		On steadily	Clock is not working.

RELATED DOCUMENTATION

[Connect a PTX10016 Router to a Network for Out-of-Band Management | 230](#)

[How to Handle and Store PTX10016 Line Cards, RCBs, and SIBs | 300](#)

[Install a PTX10016 Routing and Control Board | 238](#)

PTX10016 Switch Fabric

IN THIS SECTION

- [PTX10016 Switch Interface Board Description | 78](#)
- [PTX10016 Switch Interface Board LEDs | 82](#)

Switch Interface Boards (SIBs) create the switch fabric for the PTX10016. Each PTX10016 contains six SIBs that are installed vertically, mid-chassis, between the line cards and the Routing Control Boards (RCBs) in the front and the fan trays in the rear. When all six SIBs are installed, the PTX10016 has a net routing capacity of 96 Tbps.

PTX10016 Switch Interface Board Description

The SIBs make up the PTX10016 routing plane. Five SIBs are required for operation, with the sixth providing $n+1$ redundancy. The sixth SIB is powered and available to the system at all times. Each SIB

has 16 connectors that match and connect to a connector on one of the 16 line cards. See [Figure 44 on page 79](#).

Figure 44: PTX10016 SIB

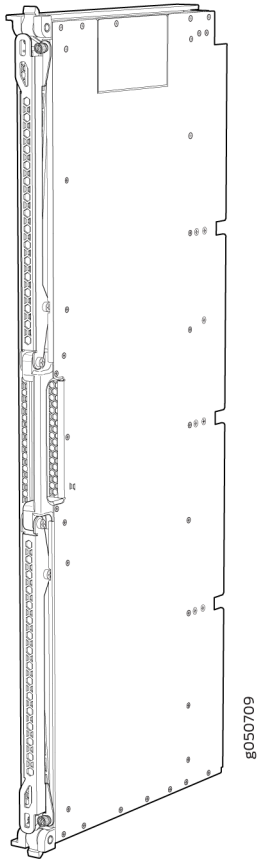

[Table 24 on page 79](#) shows the physical specifications for a PTX10016 SIB.

Table 24: Dimensions of a PTX10016 SIB

Specification	Value
Height	34.6 in. (87.88 cm)
Width	1.8 in. (4.57 cm)

Table 24: Dimensions of a PTX10016 SIB (Continued)

Specification	Value
Depth	13.4 in. (34.04 cm)
Weight	35.2 lb (15.97 kg)

SIBs are hot-removable and hot-insertable field-replaceable units (FRUs). They are not visible from the outside of the router chassis. You must remove one of the fan trays in order to view the SIBs. The SIBs

are numbered from left to right **SIB0** to **SIB5**, with **SIB0** located next to the power supplies. See [Figure 45 on page 81](#).

Figure 45: SIBs Installed in a PTX10016

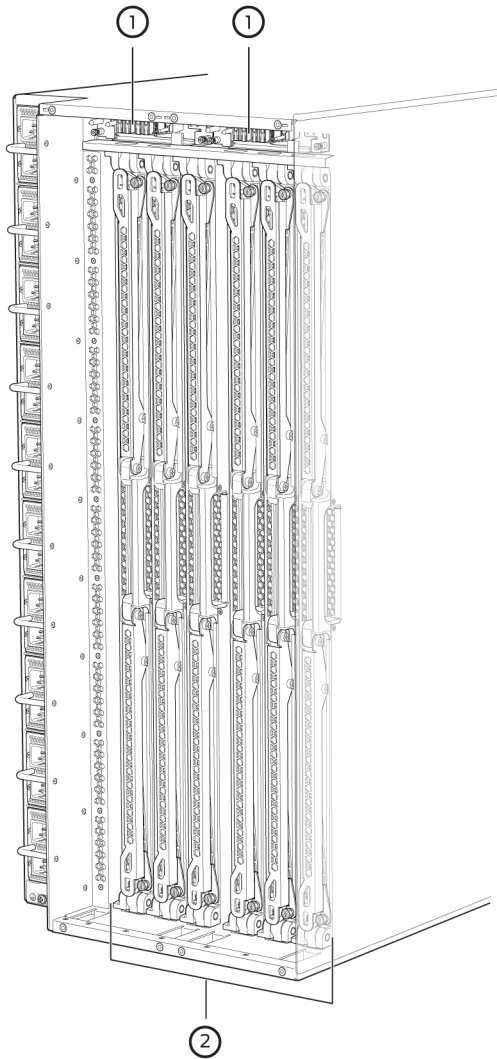

8050703

1– Fan tray controllers

2– SIBs

SEE ALSO

[Install a PTX10016 Switch Interface Board | 303](#)

[Remove a PTX10016 Switch Interface Board | 307](#)

PTX10016 Switch Interface Board LEDs

The Switch Interface Board (SIB) has two status LEDs at the top of each board. See [Figure 46 on page 82](#).

Figure 46: SIB LEDs

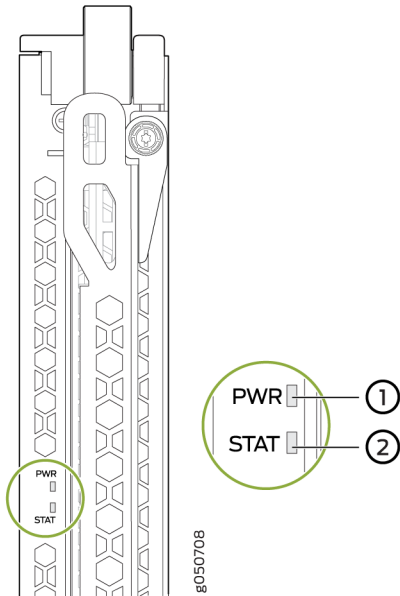

[Table 25 on page 82](#) describes the functions of these LEDs.

Table 25: SIB LEDs

Label	Color	State	Description
PWR (Power)	Green	On steadily	The SIB is receiving power.
	Yellow	Blinking	Power fault.
	Unlit	Off	The SIB is either offline or not receiving power.
STAT (Status)	Green	On steadily	The SIB is online and functioning normally.

Table 25: SIB LEDs (*Continued*)

Label	Color	State	Description
	Green	Blinking	The beacon feature is enabled.
	Yellow	On steadily	The SIB has failed.
	Unlit	Off	The SIB is offline.

SEE ALSO

| [How to Handle and Store PTX10016 Line Cards, RCBs, and SIBs](#) | 300

PTX10016 Line Card Components and Descriptions

IN THIS SECTION

- [PTX10K-LC1101 Line Card](#) | 85
- [PTX10K-LC1102 Line Card](#) | 88
- [PTX10K-LC1104 Line Card](#) | 96
- [1.2-Terabyte Per Second DWDM OTN Module Wavelengths](#) | 107
- [PTX10K-LC1105 Line Card](#) | 133
- [QFX10000-60S-6Q Line Card](#) | 136
- [PTX10016 Line-Card LEDs](#) | 143
- [Taking a Line Card Offline](#) | 144

The line cards in PTX10016 routers combine a Packet Forwarding Engine and Ethernet interfaces in a single assembly. Line cards are field-replaceable units (FRUs) that can be installed in the line-card slots

on the front of the router chassis. The PTX10016 chassis supports up to 16 line cards. See [Table 26 on page 84](#) for line cards that operate in the PTX10016.

Table 26: Compatible Line Cards for the JNP10008-SF Switch Fabric

Line Card	Description	Supported Switch Fabric	Dimensions	Net Shipping Weight
PTX10K-LC1101	30-port 100-Gigabit or 40-Gigabit Ethernet	JNP10016-SF	17.2 in. x 1.89 in x 20.5 in 43.68 cm x 4.8 cm x 52.07 cm	27 lbs 12.2 kg
PTX10K-LC1102	36-port 40-Gigabit Ethernet; 12 ports support either 100-Gigabit or 40-Gigabit Ethernet	JNP10016-SF	17.2 in. x 1.89 in x 20.5 in 43.68 cm x 4.8 cm x 52.07 cm	22.6 lbs 10.25 kg
PTX10K-LC1104	6-port DWDM with MACsec with flexible modulation at 100-Gbps, 150-Gbps, and 200-Gbps	JNP10016-SF	17.2 in. x 1.89 in x 20.5 in 43.68 cm x 4.8 cm x 52.07 cm	32 lbs 14.5 kg
PTX10K-LC1105	30-port 100-Gigabit or 40-Gigabit Ethernet with MACsec	JNP10016-SF	17.2 in. x 1.89 in x 20.5 in 43.68 cm x 4.8 cm x 52.07 cm	28.5 lbs 12.93 kg
QFX10000-60S-6Q	60-port 10-Gigabit or 1-Gigabit Ethernet; 2-port of 40-Gigabit or 100-Gigabit Ethernet; 4 port of 40-Gigabit	JNP10016-SF	17.2 in. x 1.89 in x 20.5 in 43.68 cm x 4.8 cm x 52.07 cm	9.7 lbs 4.39 kg

PTX10K-LC1101 Line Card

IN THIS SECTION

- Overview | 85
- Channelizing 40-Gigabit Ethernet Ports | 86
- Network ports | 87

Overview

The PTX10K-LC1101 line card consists of 30 quad small form-factor pluggable (QSFP28) cages that support either 40-Gigabit Ethernet or 100-Gigabit Ethernet optical transceivers; see [Figure 47 on page 85](#). The PTX10K-LC1101 line cards also support 10-Gigabit Ethernet interfaces. For 10-Gigabit Ethernet, you must configure the port using the channelization-speed command. By default, the interfaces are created with 100-Gbps port speed. If the user plugs in a 40GE or 4*10GE transceiver, you must configure the appropriate port speed manually using the CLI.

The PTX10K-LC1101 line card runs Juniper Networks Junos OS for PTX Series software on Juniper Networks PTX10K-LC1101 hardware. The PTX10K-LC1101 line card is supported on Junos OS Release 17.2R1 and later.

Figure 47: PTX10K-LC1101 Port Panel

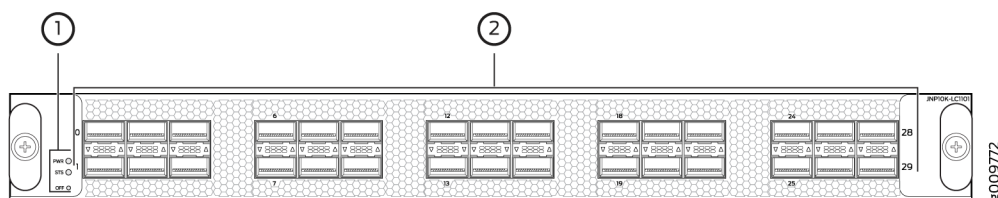

1– Power LED (**PWR**), status :LED (**STS**), and offline/online button (**OFF**)

2– Network ports

Each network port can operate as a:

- 100-Gigabit Ethernet port when you use QSFP28 optical transceivers.
- 40-Gigabit Ethernet port when you use QSFP+ optical transceivers.

To change from the default mode (100-Gigabit Ethernet) to 40-Gigabit Ethernet channelized mode, use the Junos OS operational command `set chassis fpc slot-number pic 0 port port number channelization-speed 10g`.

Channelizing 40-Gigabit Ethernet Ports

Each of the 40-Gigabit Ethernet ports on the PTX10K-LC1101 line card can be channelized into four 10-Gigabit Ethernet, or channels. When ports are in channelization mode, the fourth port on each Packet Forwarding Engine is disabled, and the remaining four ports that are mapped to the same Packet Forwarding Engine can be used as either 4x10-Gigabit Ethernet, 40-Gigabit Ethernet, or 100-Gigabit Ethernet ports. The channelization mode works independently for each of the Packet Forwarding Engines on the PTX10K-LC1101 line card. See [Figure 48 on page 86](#) to see which ports are disabled and see [Table 27 on page 86](#) for the maximum port configurations.

Figure 48: Disabled Ports in Channelization Mode

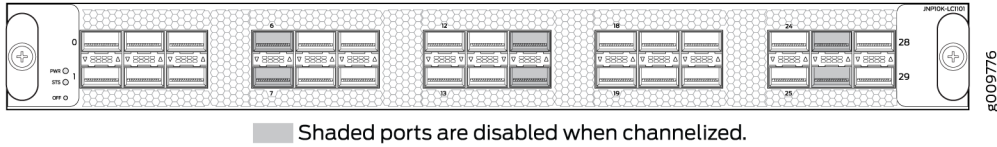

Table 27: Maximum Port Configuration

Port Speed	Nonchannelized Mode (Mode D)	Channelized Mode (Mode A)
100 Gbps	30 or	24 or
40 Gbps	30	24 or
10 Gbps	0	96

Unlike the PTX10K-LC1102 line card, the PTX10K-LC1101 line card does not have port groups; instead, port behavior is tied to the ASIC associated with the port. You must configure each port individually, in order to channelize a 40-Gigabit Ethernet port to 4 independent 10-Gigabit Ethernet ports. For example, ASIC PE0 maps to ports 0, 2, 4, 6, and 8. The fourth port, port 6, is disabled. See [Table 28 on page 87](#) for the list of available ports and the associated ASIC mapping in [Figure 48 on page 86](#) to locate the available and disabled ports.

NOTE: If you change the channelization mode (mode D to mode A or mode A to mode D), the new port speed configuration does not cause an FPC to reboot automatically, but it triggers an FPC need bounce alarm. To ensure that the new port speed configuration takes effect, you must manually reboot the FPC. The alarm is cleared when you manually reboot the FPC or delete the new port speed configuration.

NOTE: When port speeds are changed manually from one setting to another, or when the interface is deactivated, the `show interface interface-name` command shows the error `Device interface-name not found` for a brief interval. Ensure that the transceiver is in a working condition. The interface comes up subsequently.

Table 28: Port Mapping for Channelization

ASIC	Available Ports	Disabled Port
PE0	0, 2, 4, 8	6
PE1	1, 3, 5, 9	7
PE2	10, 12, 14, 18	16
PE3	11, 13, 15, 19	17
PE4	20, 22, 24, 28	26
PE5	21, 23, 25, 29	27

Network ports

Each of the 30 QSFP28 ports supports:

- 100-Gigabit Ethernet using QSFP28 optical transceivers.
- 40-Gigabit Ethernet using QSFP+ optical transceivers.

- 40-Gigabit Ethernet to 10-Gigabit/1-Gigabit QSFP-to-SFP adapter (QSA) (Junos OS Release 18.4R1 and later).

PTX10K-LC1102 Line Card

IN THIS SECTION

- Overview | 88
- Network Ports | 89
- Channelization | 89
- Port Status and Activity LEDs | 94

Overview

The PTX10K-LC1102 line card consists of 36 quad small form-factor pluggable plus (QSFP+) ports that support 40-Gigabit Ethernet optical transceivers. Out of these 36 ports, 12 ports can also support 100-Gigabit Ethernet QSFP28 transceivers. The PTX10K-LC1102 line cards also support 10-Gigabit Ethernet interfaces. You can channelize 40-Gigabit Ethernet ports to four independent 10-Gigabit Ethernet interfaces by configuring the port speed and cabling the port using fiber breakout cables. See [Figure 49 on page 88](#).

The PTX10K-LC1102 line card runs Juniper Networks Junos OS for PTX Series software on Juniper Networks PTX10K-LC1102 hardware. The PTX10K-LC1102 line card is supported on Junos OS Release 17.2R1 and later.

Figure 49: PTX10K-LC1102 Port Panel

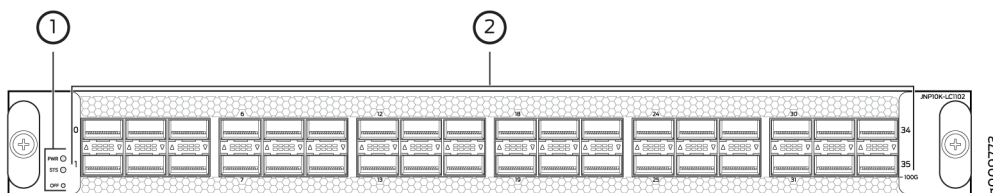

1– Power LED (**PWR**), status LED (**STS**) and offline/online button (**OFF**)

2– Network ports

Each QSFP28 port can be configured as:

- 100 m-Gigabit Ethernet port using QSFP28 optical transceivers. Only the ports with a fine black line underneath the port are capable for 100-Gigabit Ethernet. When a QSFP28 transceiver is inserted into these ports and you configure the port for 100-Gigabit Ethernet, the two adjacent ports are disabled and the QSFP28 port is enabled for 100-Gigabit Ethernet.
- 40-Gigabit Ethernet port using QSFP+ optical transceivers.
- 10-Gigabit Ethernet port using breakout cabling and attached optical transceivers. When configured for channelization, the system converts the 40-Gigabit Ethernet port into four independent 10-Gigabit Ethernet channels.

Network Ports

Each of the 12 QSFP28 ports supports:

- 100-Gigabit Ethernet QSFP28 transceivers
- 40-Gigabit Ethernet QSFP+ transceivers
- 40-Gigabit Ethernet to 10-Gigabit/1-Gigabit QSA (Junos OS Release 18.4R1 and later)

Each of the 36 QSFP+ ports supports:

- 40-Gigabit Ethernet QSFP+ transceivers
- 40-Gigabit Ethernet to 10-Gigabit/1-Gigabit QSA (Junos OS Release 18.4R1 and later)

Channelization

Every second and sixth port in a 6xQSFP cage on a PTX10K-LC1102 line card supports 100-Gigabit Ethernet using QSFP28 transceivers. These 100-Gigabit Ethernet ports operate either as 100-Gigabit Ethernet ports or as 40-Gigabit Ethernet, but are recognized as channelized 4x10-Gigabit Ethernet by default. See [Figure 50 on page 90](#) for a closeup view of a 6xQSFP+ cage. When a 40-Gigabit Ethernet transceiver is inserted into a 100-Ethernet port, the port recognizes the 40-Gbps port speed. When a 100-Gigabit Ethernet transceiver is inserted into the port and enabled in the CLI, the port recognizes the 100-Gbps speed and disables two adjacent 40-Gigabit Ethernet ports. See [Figure 51 on page 90](#) and [Figure 52 on page 90](#). You can also use a 100-Gigabit Ethernet transceiver and run it at 40-Gigabit Ethernet by using the CLI to set the port speed to 40-Gigabit Ethernet.

Figure 50 on page 90 shows the default configuration of a cage of ports on the PTX10K-LC1102.

Figure 50: All Ports Are Enabled for Channelized 4x10-Gigabit Ethernet by Default

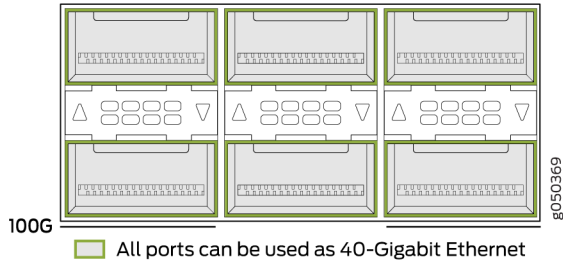

Figure 51: 100-Gigabit Ethernet Ports Can Operate at Either 100 Gbps or 4x10 Gbps Speeds

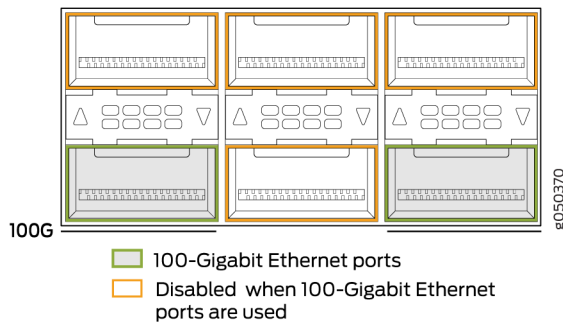
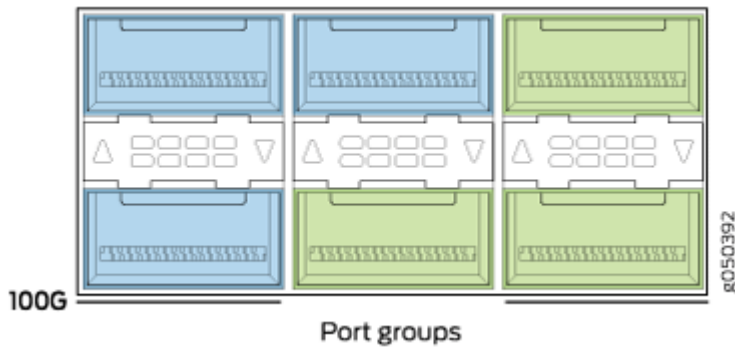

Figure 52: Enabled 100-Gigabit Ethernet Port Creates a Port Group and Disables the Associated 40-Gigabit Ethernet Port



The 40-Gigabit Ethernet ports can operate independently, be channelized into four 10-Gigabit Ethernet ports, or bundled with the next two consecutive ports and channelized into twelve 10-Gigabit Ethernet

ports as a port range. Only the first and fourth port in each 6xQSFP cage are available to channelize a port range (see [Figure 53 on page 91](#)). The port speed must be configured using the `set chassis fpc pic port speed` command. For example, to set the first router port as 40-Gigabit Ethernet (not channelized), use the `set chassis fpc 0 pic 0 port 0 speed 40g` command.

Figure 53: Use the First and Fourth Port in Each 6XQSFP Cage to Channelize a Port Range

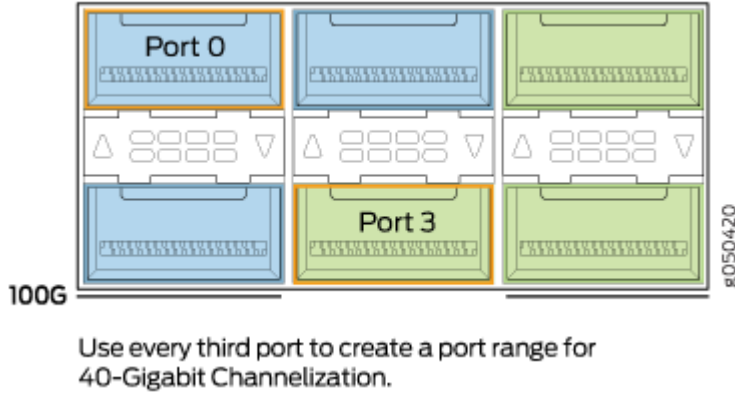

[Table 29 on page 91](#) shows the available combinations for the ports. On the PTX10K-LC1102, the ports are enabled by default.

Table 29: PTX10K-LC1102 Port Mapping

Port Number	4X10-Gigabit Ethernet	4X10-Gigabit Channelized Port Group	40-Gigabit Ethernet	100-Gigabit Ethernet	100-Gigabit Ethernet Disables
0	✓	✓	✓	-	-
1	✓		✓	✓	0, 2
2	✓		✓	-	-
3	✓	✓	✓	-	-
4	✓		✓	-	-

Table 29: PTX10K-LC1102 Port Mapping (Continued)

Port Number	4X10-Gigabit Ethernet	4X10-Gigabit Channelized Port Group	40-Gigabit Ethernet	100-Gigabit Ethernet	100-Gigabit Ethernet Disables
5	✓		✓	✓	3, 4
6	✓	✓	✓	-	-
7	✓		✓	✓	6, 8
8	✓		✓	-	-
9	✓	✓	✓	-	-
10	✓		✓	-	-
11	✓		✓	✓	9, 10
12	✓	✓	✓	-	-
13	✓		✓	✓	12, 14
14	✓		✓	-	-
15	✓	✓	✓	-	-
16	✓		✓	-	-
17	✓		✓	✓	15, 16
18	✓	✓	✓	-	-

Table 29: PTX10K-LC1102 Port Mapping (Continued)

Port Number	4X10-Gigabit Ethernet	4X10-Gigabit Channelized Port Group	40-Gigabit Ethernet	100-Gigabit Ethernet	100-Gigabit Ethernet Disables
19	✓		✓	✓	18, 20
20	✓		✓	-	-
21	✓	✓	✓	-	-
22	✓		✓	-	-
23	✓		✓	✓	21, 22
24	✓	✓	✓	-	-
25	✓		✓	✓	24, 26
26	✓		✓	-	-
27	✓	✓	✓	-	-
28	✓		✓	-	-
29	✓		✓	✓	27, 28
30	✓	✓	✓	-	-
31	✓		✓	✓	30, 32
32	✓		✓	-	-

Table 29: PTX10K-LC1102 Port Mapping (Continued)

Port Number	4X10-Gigabit Ethernet	4X10-Gigabit Channelized Port Group	40-Gigabit Ethernet	100-Gigabit Ethernet	100-Gigabit Ethernet Disables
33	✓	✓	✓	-	-
34	✓		✓	-	-
35	✓		✓	✓	33, 34

Port Status and Activity LEDs

Each network port has a bi-colored up or down LED indicator that show ports status and link activity based on whether or not the port is configured for channelization. See [Figure 54 on page 94](#), [Table 30 on page 94](#) and [Table 31 on page 95](#).

Figure 54: Link/Activity Indicators for Network Ports on PTX10K-LC1102 Line Cards

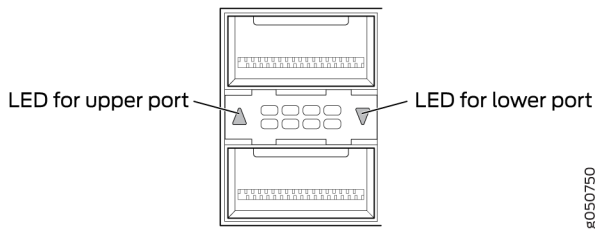

Table 30: Unchannelized Network Port Link/Activity LEDs on a PTX10K-LC1102 Line Card

Color	State	Description
Unlit	Off	The port is administratively disabled, there is no power, the link is down, or a transceiver is not present.

Table 30: Unchannelized Network Port Link/Activity LEDs on a PTX10K-LC1102 Line Card (Continued)

Color	State	Description
Green	On steadily	A link is established but there is no activity.
	Blinking	A link is up and there is activity.
Yellow or Amber	Slow blink or blip	The beacon function was enabled on the port.
	Blinking	A single LED blinking indicates an interface fault.

Table 31: Channelized Network Port Link/Activity LEDs on a PTX10K-LC1102 Line Card

Color	State	Description
Unlit	Off	The port is administratively disabled, there is no power, the link is down, or a transceiver is not present. All sub-channels are disabled.
Green	On steadily	A link is established. When channelized, all sub-channels are up. When not channelized, it indicates no activity.
	Blinking	A link is up and there is activity. When not channelized, it indicates the port is up and active in either 40-Gigabit or 100-Gigabit mode. When channelized, all four channels are up and active.
Yellow or Amber (channelized)	On steadily	At least one channel link is up, but not all channels are up. There is no activity on the channel link.
	Flashing	At least one channel link is up, but not all channels are up. There is activity on the channel link.

Table 31: Channelized Network Port Link/Activity LEDs on a PTX10K-LC1102 Line Card (Continued)

Color	State	Description
	Slow blink, or blip	The beacon function is enabled on one or more sub-channels.
	Blinking	One or more sub-channels has a fault condition.
Yellow or Amber	Blinking	A single LED blinking indicates an interface fault. All four LEDs blink to indicate the beacon function was enabled on the port.

PTX10K-LC1104 Line Card

IN THIS SECTION

- [Hardware Features | 96](#)
- [Compatibility | 99](#)
- [Optical Transmit Specifications | 100](#)
- [Optical Receive Specifications | 101](#)
- [Status and Activity LEDs | 102](#)
- [Optical and Ethernet Interface Alarms and Defects | 104](#)

Hardware Features

The PTX10K-LC1104 line card provides up to 1.2 Tbps of packet forwarding for cloud providers, service providers, and enterprises that need coherent dense wavelength-division multiplexing (DWDM) with MACsec security features. The 6-port line card, with built-in optics, supports flexible rate modulation at 100-Gbps, 150-Gbps, and 200-Gbps speeds. A maximum of four PTX10K-LC1104 coherent line cards are supported on the PTX10008 and PTX10016 Packet Transport Routers. See [Figure 55 on page 97](#).

The PTX10K-LC1104 line card runs Juniper Networks Junos OS for PTX Series software on Juniper Networks JNP10K-LC1104 hardware. The PTX10K-LC1104 line card is supported on Junos OS Release 17.4R1-S1 and later on PTX10008 and Junos OS Release 18.3R1 on PTX10016 routers.

Figure 55: PTX10K-LC1104 Port Panel

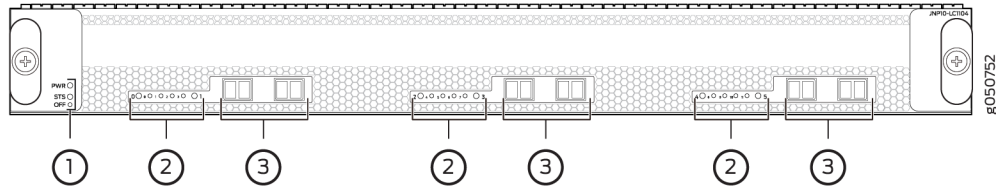

1– Power LED (**PWR**), status LED (**STS**) and offline/online button (**OFF**)

3– Ports with embedded optics

2– Network link and Ethernet link LEDs

Each PTX10K-LC1104 has six physical interfaces (ot-x/x/x) that connect to one of three built-in flexible rate optical transponders for a maximum of 24 physical interfaces on a PTX10008 or PTX10016 system. Each transponder connects four 100-Gigabit Ethernet logical interfaces (et-x/x/x) to one of three

forwarding ASICs. These forwarding ASICs are responsible for optional MACsec encryption on each 100-Gigabit Ethernet interface. See [Figure 56 on page 98](#).

Figure 56: PTX10K-LC1104 Interfaces

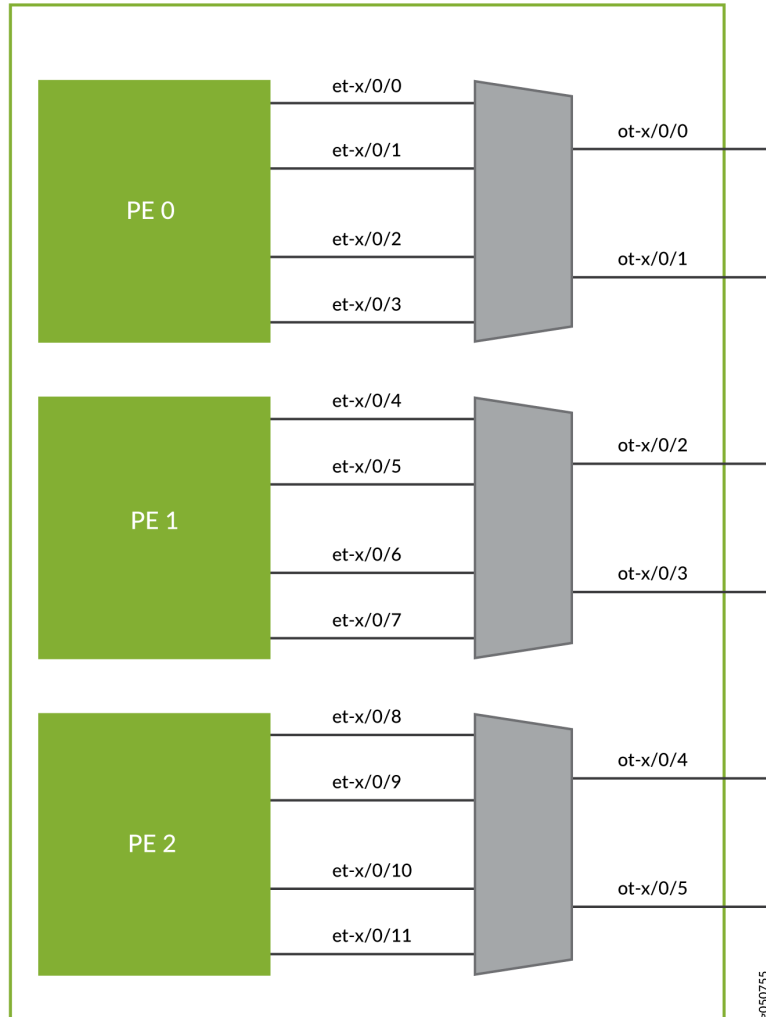

NOTE: All optical properties are configured under the ot interface. Use the **set interfaces ot-x/x/x optics-options** CLI command to set these options. Perform MACsec configuration on the et-interface using the **set security macsec connectivity-association ca-name encryption-algorithm**. Optical transport network (OTN)-related configurations also are done on the et-interface.

Each of the six network ports can operate in one of three modulation formats; see [Table 32 on page 99](#).

Table 32: PTX10K-LC1104 Modulation Formats

Speed	Modulation	Distance
100 Gbps	DP-QPSK	long haul–4000 km
150 Gbps	DP-8QAM	regional or metro–2000 km
200 Gbps	DP-16QAM	metro DCI–1000 km

Compatibility

The Juniper Networks integrated DWDM solution includes integrated 100-Gigabit Ethernet coherent optics on Juniper Networks QFX Series Switches; MX Series 5G Universal Routing Platforms, and PTX Series Packet Transport Routers; and BTI Packet Optical Platforms optimized for DCI. As part of the Open Cloud Interconnect solution, the PTX10K-LC1104 coherent line card is compatible with many third-party optical products as well as Juniper Networks optical solutions and offerings. The PTX10K-LC1104 coherent line card is interoperable with the BTI Series Packet Optical Transport UFM6 in 100-Gbps and 200-Gbps modes. It is also compatible with the MX Series MICs and PTX Series PICs in 100-Gbps mode. See [Table 33 on page 99](#).

Table 33: Juniper Networks Compatible Products in 100 Gbps Mode

Platform	Product	Model Information
PTX Series	PTX-5-100-WDM	See the Hardware Compatibility Tool, PTX-5-100-WDM .
MX Series	MIC3-100G-DWDM	See the Hardware Compatibility Tool, MIC3-100G-DWDM .
QFX Series	QFX10K-12C-DWDM	See the Hardware Compatibility Tool, QFX10K-12C-DWDM .

Optical Transmit Specifications

The line card is connected using single-mode fiber (SMF) and LC connectors. See [Table 34 on page 100](#) and [Table 35 on page 101](#) for the optical transponder specifications.

Table 34: PTX10K-LC1104 Optical Transmit Specifications

Specification	Value
Standards compliance	IEEE 802.3 IEC 60825-1 Class 1
Modulation format	DP-QPSK, DP-8QAM, DP-16QAM
Line rate	DP-QPSK = 136.66 Gbps DP-8QAM = 205 Gbps DP-16QAM = 273.33 Gbps
FEC types	15% or 25% SD-FEC
Channel-plan wavelength range	Extended C-band, 1528.77 nm to 1566.72 nm
Channel-plan frequency range	196.1 THz to 191.35 THz
Channel spacing	37.5 GHz, 50 GHz, and 100 GHz
Channel tunability	12.5 GHz grid. See 1.2-Terabyte Per Second DWDM OTN Module Wavelengths .
Optical transmitter output power (on)	-12 to 1.5 dBm, 0.1 dB steps, +/-1 dB accuracy
Optical transmitter output power (off)	≤ -40 dBm
Optical transmitter wavelength accuracy	+/-1.8 GHz

Table 34: PTX10K-LC1104 Optical Transmit Specifications (Continued)

Specification	Value
Optical transmitter channel tuning time	≤ 90 seconds across C-band
TX output optical signal-to-noise ration (OSNR)	≥ 36 dB

Optical Receive Specifications

Table 35: PTX10K-LC1104 Optical Receive Specifications

Specification	100G DP-PSK	150G DP-8QAM	200G DP-16QAM
Optical receiver input power range (low Rx OSNR)	−18 dBm to 0 dBm	−18 dBm to 0 dBm	−18 dBm to 0 dBm
Optical receiver input power range (unamplified /dark fiber applications)	−32 dBm to 0 dBm	−27 dBm to 0 dBm	−25 dBm to 0 dBm
Optical receiver damage input power threshold	+17 dBm	+17 dBm	+17 dBm
Optical receiver minimum OSNR (back-to-back), typical	10.3 dB	14.7 dB	17.6 dB
Optical receiver minimum OSNR (back-to-back), worst-case, EOL	11.5 dB	16.0 dB	19.0 dB
Optical receiver chromatic dispersion tolerance	+/- 70,000 ps/nm	+/- 45,000 ps/nm	+/-30,000 ps/nm
Optical receiver PMD tolerance	30 ps mean DGD	20 ps mean DGD	15 ps mean DGD

Table 35: PTX10K-LC1104 Optical Receive Specifications (Continued)

Specification	100G DP-PSK	150G DP-8QAM	200G DP-16QAM
Optical receiver polarization tracking	100 krad/s	50 krad/s	50 krad/s

Status and Activity LEDs

There are two types of LEDs for the network ports: port LEDs and Ethernet link LEDs. The LEDs for the six physical ports indicate the link state of an ot-interface. There are four LEDs in between each port pair that indicate the link state of the associated et-interfaces, (see [Figure 57 on page 102](#)). To determine the link state of the ot-interface see [Table 36 on page 102](#).

Figure 57: DWDM Port and Ethernet Link State LEDs

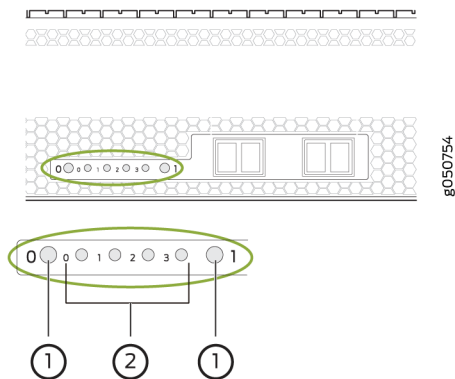

1– Port LEDs (ot-interfaces)

2– Ethernet LEDs (et-link interfaces)

Table 36: Network Port Status LEDs (ot Interfaces)

Color	Description
Unlit	The port is not configured.
Solid green	A link is established on the ot interface.

Table 36: Network Port Status LEDs (ot Interfaces) (Continued)

Color	Description
Solid amber	The optical module associated with the port has a fault condition, or the port is configured but the link is down.

You can also determine the configuration of the et interfaces by examining the pattern of the four Ethernet LEDs. See [Table 37 on page 103](#). To determine the link status and of those et interfaces, see [Table 38 on page 104](#).

Table 37: Valid et Interface Link Combinations of Every Two ot Ports

Modulation Format	Aggregate Data Rate	ot Interface Data Rate		et Interface	Configuration
		Ports 0, 2, 4	1, 3, 5		
16-QAM (x2)	4 x 100-Gigabit Ethernet	200 Gbps	200 Gbps	0, 1, 2, 3	2 independent 200 Gbps 16-QAM
QPSK and 16-QAM	3 x 100-Gigabit Ethernet	100 Gbps	200 Gbps	0, 2, 3	Independent QPSK and 16-QAM
16-QAM and QPSK	3 x 100-Gigabit Ethernet	200 Gbps	100 Gbps	0, 1, 2	Independent QPSK and 16-QAM
8-QAM	3 x 100-Gigabit Ethernet	150 Gbps	150 Gbps	0, 1, 2	2 Coupled 150 Gbps 8-QAM
QPSK and QPSK	2 x 100-Gigabit Ethernet	100 Gbps	100 Gbps	0,2	Independent 100 Gbps QPSK

Table 38: Ethernet Link LEDs (et Interfaces)

Color	Description
Unlit	The et-interface is down.
Solid green	The et-interface is up but there is no activity.
Blinking green	The link is up on the et-interface and there is activity.

Optical and Ethernet Interface Alarms and Defects

[Table 39 on page 104](#) and [Table 40 on page 106](#) describe the ot and et interface alarms and defects that can occur on the line card and the link status when the alarm or defect occurs.

TIP: You can view optical and Ethernet alarms and defects by using the `show interfaces interface-name extensive operational-mode` CLI command.

Table 39: OT Interface Alarms and Defects

Category	Alarm	Description	Link Status
OTN	Network lane LOS	Loss of signal	Link down
	Network lane LOF	Loss of frame	Link down
	Network lane LOM	Loss of multiframe	Link down
	Network lane OTU-BDI	Backward defect identification	Link down

Table 39: OT Interface Alarms and Defects (Continued)

Category	Alarm	Description	Link Status
OTN FEC	FEC degrade (OTU-FEC-DEG)	Forward error correction degraded	Link down if signal degrade or backward FRR thresholds are met
	FEC excessive (OTU-FEC-EXE)	There are uncorrected words and there are errors in the frame header.	Possible link down
Optics and Optical Channel	Module fault	Module fault state	Link down
	Rx modem synch fault	Modem sync detect fault	Link down
	Rx modem loss of lock OTU-BDI	Modem lock fault	Link down
	Rx loss of alignment	Loss of alignment fault	Link down
	Network lane LOS	Lane Rx loss of signal	Alarm
	Modulator bias control loop fail	Modulator bias control loop failed to converge.	Alarm
	ITLA fault	ITLA operation failure	Alarm
	DAC calibration fault	DAC calibration fault	Alarm
	ADC calibration fault	ACD calibration fault	Alarm

Table 40: ET Interface Alarms and Defects

Category	Alarm	Description	Link Status
OTN	LOS	Loss of signal	Alarm
	LOF	Loss of frame	Alarm
	LOM	Loss of multiframe	Alarm
OTN OTU	OTU-AIS	Alarm indication signal or all ones signal	Alarm
	OTU-BDI	Backward defect identification	Alarm
	OTU-IAE	Incoming alignment error	Warning
	OTU-TTIM	Destination access point identifier (DAPI), source access point identifier (SAPI), or both mismatch from expected to received	Warning
	OTU-BIAE	Backward incoming alignment error	Warning
	OTU-TSF	OTU trail signal fail	Warning
	OTU-SSF	OTU server signal fail	Warning
OTN ODU	ODU-AIS	Alarm indication signal or all one signal	Alarm
	ODU-OCI	Open connection error	Alarm
	ODU-LCK	ODU lock triggers for path monitoring and TCM levels 1 through 6	Alarm
	ODU-BDI	Backward defect indication	Alarm

Table 40: ET Interface Alarms and Defects (Continued)

Category	Alarm	Description	Link Status
	ODU-TTIM	DAPI or SAPI mismatch from expected to received	Warning
	ODU-IAE	Incoming alignment error	Warning
	ODU-LTC	Loss of tandem connection	Warning
	ODU-CSF	Client signal failure	Warning
	ODU-TSF	Trail signal failure	Warning
	ODU-SSF	Server signal failure	Warning
	ODU-PTIM	Payload type mismatch	Alarm

SEE ALSO

[1.2-Terabyte Per Second DWDM OTN Module Wavelengths | 107](#)

Understanding the PTX10K-LC1104 Line Card

1.2-Terabyte Per Second DWDM OTN Module Wavelengths

The PTX10K-LC1104 coherent line card and the QFX10000-12C-DWDM line card provide six 200-Gbps coherent MACsec ports with built-in long-reach optics. DWDM channel frequency offsets are 0.02 THz. The QFX10000-12C-DWDM line card is available for QFX10008 and QFX10016 switch chassis running Junos OS Release 17.3R1 and later. The PTX10K-LC1104 coherent line card is available for PTX10008 and PTX10016 routers. See [Table 41 on page 108](#) for the available channel frequencies and wavelengths.

Table 41: DWDM Module Wavelengths

Frequency (THz)	Wavelength (nm)	Offset (GHz)
191.35	1566.72	12.5/50 GHz
191.36	1566.62	12.5 GHz
191.38	1566.52	12.5 GHz
191.39	1566.42	12.5 GHz
191.4	1566.31	12.5/50/100 GHz
191.41	1566.21	12.5 GHz
191.43	1566.11	12.5 GHz
191.44	1566.01	12.5 GHz
191.45	1565.91	12.5/50 GHz
191.46	1565.8	12.5 GHz
191.48	1565.7	12.5 GHz
191.49	1565.6	12.5 GHz
191.5	1565.5	12.5/50/100 GHz
191.51	1565.39	12.5 GHz
191.53	1565.29	12.5 GHz

Table 41: DWDM Module Wavelengths (Continued)

Frequency (THz)	Wavelength (nm)	Offset (GHz)
191.54	1565.19	12.5 GHz
191.55	1565.09	12.5/50 GHz
191.56	1564.99	12.5 GHz
191.58	1564.88	12.5 GHz
191.59	1564.78	12.5 GHz
191.6	1564.68	12.5/50/100 GHz
191.61	1564.58	12.5 GHz
191.63	1564.48	12.5 GHz
191.64	1564.37	12.5 GHz
191.65	1564.27	12.5/50 GHz
191.66	1564.17	12.5 GHz
191.68	1564.07	12.5 GHz
191.69	1563.97	12.5 GHz
191.7	1563.86	12.5/50/100 GHz
191.71	1563.76	12.5 GHz

Table 41: DWDM Module Wavelengths (*Continued*)

Frequency (THz)	Wavelength (nm)	Offset (GHz)
191.73	1563.66	12.5 GHz
191.74	1563.56	12.5 GHz
191.75	1563.46	12.5/50 GHz
191.76	1563.35	12.5 GHz
191.78	1563.25	12.5 GHz
191.79	1563.15	12.5 GHz
191.8	1563.05	12.5/50/100 GHz
191.81	1562.95	12.5 GHz
191.83	1562.84	12.5 GHz
191.84	1562.74	12.5 GHz
191.85	1562.64	12.5/50 GHz
191.86	1562.54	12.5 GHz
191.88	1562.44	12.5 GHz
191.89	1562.33	12.5 GHz
191.9	1562.23	12.5/50/100 GHz

Table 41: DWDM Module Wavelengths (Continued)

Frequency (THz)	Wavelength (nm)	Offset (GHz)
191.91	1562.13	12.5 GHz
191.93	1562.03	12.5 GHz
191.94	1561.93	12.5 GHz
191.95	1561.83	12.5/50 GHz
191.96	1561.72	12.5 GHz
191.98	1561.62	12.5 GHz
191.99	1561.52	12.5 GHz
192	1561.42	12.5/50/100 GHz
192.01	1561.32	12.5 GHz
192.03	1561.22	12.5 GHz
192.04	1561.11	12.5 GHz
192.05	1561.01	12.5/50 GHz
192.06	1560.91	12.5 GHz
192.08	1560.81	12.5 GHz
192.09	1560.71	12.5 GHz

Table 41: DWDM Module Wavelengths (Continued)

Frequency (THz)	Wavelength (nm)	Offset (GHz)
192.1	1560.61	12.5/50/100 GHz
192.11	1560.51	12.5 GHz
192.13	1560.4	12.5 GHz
192.14	1560.3	12.5 GHz
192.15	1560.2	12.5/50 GHz
192.16	1560.1	12.5 GHz
192.18	1560	12.5 GHz
192.188	1559.9	12.5 GHz
192.2	1559.79	12.5/50/100 GHz
192.21	1559.69	12.5 GHz
192.23	1559.59	12.5 GHz
192.24	1559.49	12.5 GHz
192.25	1559.39	12.5/50 GHz
192.26	1559.29	12.5 GHz
192.28	1559.19	12.5 GHz

Table 41: DWDM Module Wavelengths (Continued)

Frequency (THz)	Wavelength (nm)	Offset (GHz)
192.29	1559.08	12.5 GHz
192.3	1558.98	12.5/50/100 GHz
192.31	1558.88	12.5 GHz
192.33	1558.78	12.5 GHz
192.34	1558.68	12.5 GHz
192.35	1558.58	12.5/50 GHz
192.36	1558.48	12.5 GHz
192.38	1558.38	12.5 GHz
192.39	1558.27	12.5 GHz
192.4	1558.17	12.5/50/100 GHz
192.41	1558.07	12.5 GHz
192.43	1557.97	12.5 GHz
192.44	1557.87	12.5 GHz
192.45	1557.77	12.5/50 GHz
192.46	1557.67	12.5 GHz

Table 41: DWDM Module Wavelengths (Continued)

Frequency (THz)	Wavelength (nm)	Offset (GHz)
192.48	1557.57	12.5 GHz
192.49	1557.47	12.5 GHz
192.5	1557.36	12.5/50/100 GHz
192.51	1557.26	12.5 GHz
192.53	1557.16	12.5 GHz
192.54	1557.06	12.5 GHz
192.55	1556.96	12.5/50 GHz
192.56	1556.86	12.5 GHz
192.58	1556.76	12.5 GHz
192.59	1556.66	12.5 GHz
192.6	1556.56	12.5/50/100 GHz
192.61	1556.45	12.5 GHz
192.63	1556.35	12.5 GHz
192.64	1556.25	12.5 GHz
192.65	1556.15	12.5/50 GHz

Table 41: DWDM Module Wavelengths (Continued)

Frequency (THz)	Wavelength (nm)	Offset (GHz)
192.66	1556.05	12.5 GHz
192.68	1555.95	12.5 GHz
192.69	1555.85	12.5 GHz
192.7	1555.75	12.5/50/100 GHz
192.71	1555.65	12.5 GHz
192.73	1555.55	12.5 GHz
192.74	1555.44	12.5 GHz
192.75	1555.34	12.5/50 GHz
192.76	1555.24	12.5 GHz
192.78	1555.14	12.5 GHz
192.79	1555.04	12.5 GHz
192.8	1554.94	12.5/50/100 GHz
192.81	1554.84	12.5 GHz
192.83	1554.74	12.5 GHz
192.84	1554.64	12.5 GHz

Table 41: DWDM Module Wavelengths (*Continued*)

Frequency (THz)	Wavelength (nm)	Offset (GHz)
192.85	1554.54	12.5/50 GHz
192.86	1554.44	12.5 GHz
192.88	1554.34	12.5 GHz
192.89	1554.24	12.5 GHz
192.9	1554.13	1554.134
192.91	1554.03	12.5 GHz
192.93	1553.93	12.5 GHz
192.94	1553.83	12.5 GHz
192.95	1553.73	12.5/50 GHz
192.96	1553.63	12.5 GHz
192.98	1553.53	12.5 GHz
192.99	1553.43	12.5 GHz
193	1553.33	12.5/50/100 GHz
193.01	1553.23	12.5 GHz
193.03	1553.13	12.5 GHz

Table 41: DWDM Module Wavelengths (Continued)

Frequency (THz)	Wavelength (nm)	Offset (GHz)
193.04	1553.03	12.5 GHz
193.05	1552.93	12.5/50 GHz
193.06	1552.83	12.5 GHz
193.08	1552.73	12.5 GHz
193.09	1552.63	12.5 GHz
193.1	1552.52	12.5/50/100 GHz
193.11	1552.42	12.5 GHz
193.13	1552.32	12.5 GHz
193.14	1552.22	12.5 GHz
193.15	1552.12	12.5/50 GHz
193.16	1552.02	12.5 GHz
193.18	1551.92	12.5 GHz
193.19	1551.82	12.5 GHz
193.2	1551.72	12.5/50/100 GHz
193.21	1551.62	12.5 GHz

Table 41: DWDM Module Wavelengths (Continued)

Frequency (THz)	Wavelength (nm)	Offset (GHz)
193.23	1551.52	12.5 GHz
193.24	1551.42	12.5 GHz
193.25	1551.32	12.5/50 GHz
193.26	1551.22	12.5 GHz
193.28	1551.12	12.5 GHz
193.29	1551.02	12.5 GHz
193.3	1550.92	12.5/50/100 GHz
193.31	1550.82	12.5 GHz
193.33	1550.72	12.5 GHz
193.34	1550.62	12.5 GHz
193.35	1550.52	12.5/50 GHz
193.36	1550.42	12.5 GHz
193.38	1550.32	12.5 GHz
193.39	1550.22	12.5 GHz
193.4	1550.12	12.5/50/100 GHz

Table 41: DWDM Module Wavelengths (Continued)

Frequency (THz)	Wavelength (nm)	Offset (GHz)
193.41	1550.02	12.5 GHz
193.43	1549.92	12.5 GHz
193.44	1549.82	12.5 GHz
193.45	1549.72	12.5/50 GHz
193.46	1549.62	12.5 GHz
193.48	1549.52	12.5 GHz
193.49	1549.42	12.5 GHz
193.5	1549.32	12.5/50/100 GHz
193.51	1549.22	12.5 GHz
193.53	1549.12	12.5 GHz
193.54	1549.02	12.5 GHz
193.55	1548.92	12.5/50 GHz
193.56	1548.82	12.5 GHz
193.58	1548.72	12.5 GHz
193.59	1548.62	12.5 GHz

Table 41: DWDM Module Wavelengths (Continued)

Frequency (THz)	Wavelength (nm)	Offset (GHz)
193.6	1548.52	12.5/50/100 GHz
193.61	1548.42	12.5 GHz
193.63	1548.32	12.5 GHz
193.64	1548.22	12.5 GHz
193.65	1548.12	12.5/50 GHz
193.66	1548.02	12.5 GHz
193.68	1547.92	12.5 GHz
193.69	1547.82	12.5 GHz
193.7	1547.72	12.5/50/100 GHz
193.71	1547.62	12.5 GHz
193.73	1547.52	12.5 GHz
193.74	1547.42	12.5 GHz
193.75	1547.32	12.5/50 GHz
193.76	1547.22	12.5 GHz
193.78	1547.12	12.5 GHz

Table 41: DWDM Module Wavelengths (Continued)

Frequency (THz)	Wavelength (nm)	Offset (GHz)
193.79	1547.02	12.5 GHz
193.8	1546.92	12.5/50/100 GHz
193.81	1546.82	12.5 GHz
193.83	1546.72	12.5 GHz
193.84	1546.62	12.5 GHz
193.85	1546.52	12.5/50 GHz
193.86	1546.42	12.5 GHz
193.88	1546.32	12.5 GHz
193.89	1546.22	12.5 GHz
193.9	1546.12	12.5/50/100 GHz
193.91	1546.02	12.5 GHz
193.93	1545.92	12.5 GHz
193.94	1545.82	12.5 GHz
193.95	1545.72	12.5/50 GHz
193.96	1545.62	12.5 GHz

Table 41: DWDM Module Wavelengths (Continued)

Frequency (THz)	Wavelength (nm)	Offset (GHz)
193.98	1545.52	12.5 GHz
193.99	1545.42	12.5 GHz
194	1545.32	12.5/50/100 GHz
194.01	1545.22	12.5 GHz
194.03	1545.12	12.5 GHz
194.04	1545.02	12.5 GHz
194.05	1544.92	12.5/50 GHz
194.06	1544.82	12.5 GHz
194.08	1544.73	12.5 GHz
194.09	1544.63	12.5 GHz
194.1	1544.53	12.5/50/100 GHz
194.11	1544.43	12.5 GHz
194.13	1544.33	12.5 GHz
194.14	1544.23	12.5 GHz
194.15	1544.13	12.5/50 GHz

Table 41: DWDM Module Wavelengths (Continued)

Frequency (THz)	Wavelength (nm)	Offset (GHz)
194.16	1544.03	12.5 GHz
194.18	1543.93	12.5 GHz
194.19	1543.83	12.5 GHz
194.2	1543.73	12.5/50/100 GHz
194.21	1543.63	12.5 GHz
194.23	1543.53	12.5 GHz
194.24	1543.43	12.5 GHz
194.25	1543.33	12.5/50 GHz
194.26	1543.23	12.5 GHz
194.28	1543.14	12.5 GHz
194.29	1543.04	12.5 GHz
194.3	1542.94	12.5/50/100 GHz
194.31	1542.84	12.5 GHz
194.33	1542.74	12.5 GHz
194.34	1542.64	12.5 GHz

Table 41: DWDM Module Wavelengths (Continued)

Frequency (THz)	Wavelength (nm)	Offset (GHz)
194.35	1542.54	12.5/50 GHz
194.36	1542.44	12.5 GHz
194.38	1542.34	12.5 GHz
194.39	1542.24	12.5 GHz
194.4	1542.14	12.5/50/100 GHz
194.41	1542.04	12.5 GHz
194.43	1541.94	12.5 GHz
194.44	1541.85	12.5 GHz
194.45	1541.75	12.5/50 GHz
194.46	1541.65	12.5 GHz
194.48	1541.55	12.5 GHz
194.49	1541.45	12.5 GHz
194.5	1541.35	12.5/50/100 GHz
194.51	1541.25	12.5 GHz
194.53	1541.15	12.5 GHz

Table 41: DWDM Module Wavelengths (Continued)

Frequency (THz)	Wavelength (nm)	Offset (GHz)
194.54	1541.05	12.5 GHz
194.55	1540.95	12.5/50 GHz
194.56	1540.85	12.5 GHz
194.58	1540.76	12.5 GHz
194.59	1540.66	12.5 GHz
194.6	1540.56	12.5/50/100 GHz
194.61	1540.46	12.5 GHz
194.63	1540.36	12.5 GHz
194.64	1540.26	12.5 GHz
194.65	1540.16	12.5/50 GHz
194.66	1540.06	12.5 GHz
194.68	1539.96	12.5 GHz
194.69	1539.87	12.5 GHz
194.7	1539.77	12.5/50/100 GHz
194.71	1539.67	12.5 GHz

Table 41: DWDM Module Wavelengths (*Continued*)

Frequency (THz)	Wavelength (nm)	Offset (GHz)
194.73	1539.57	12.5 GHz
194.74	1539.47	12.5 GHz
194.75	1539.37	12.5/50 GHz
194.76	1539.27	12.5 GHz
194.78	1539.17	12.5 GHz
194.79	1539.07	12.5 GHz
194.8	1538.98	12.5/50/100 GHz
194.81	1538.88	12.5 GHz
194.83	1538.78	12.5 GHz
194.84	1538.68	12.5 GHz
194.85	1538.58	12.5/50 GHz
194.86	1538.48	12.5 GHz
194.88	1538.38	12.5 GHz
194.89	1538.29	12.5 GHz
194.9	1538.19	12.5/50/100 GHz

Table 41: DWDM Module Wavelengths (*Continued*)

Frequency (THz)	Wavelength (nm)	Offset (GHz)
194.91	1538.09	12.5 GHz
194.93	1537.99	12.5 GHz
194.94	1537.89	12.5 GHz
194.95	1537.79	12.5/50 GHz
194.96	1537.69	12.5 GHz
194.98	1537.59	12.5 GHz
194.99	1537.5	12.5 GHz
195	1537.4	12.5/50/100 GHz
195.01	1537.3	12.5 GHz
195.03	1537.2	12.5 GHz
195.04	1537.1	12.5 GHz
195.05	1537	12.5/50 GHz
195.06	1536.9	12.5 GHz
195.08	1536.8	12.5 GHz
195.09	1536.7	12.5 GHz

Table 41: DWDM Module Wavelengths (Continued)

Frequency (THz)	Wavelength (nm)	Offset (GHz)
195.1	1536.6	12.5/50/100 GHz
195.11	1536.51	12.5 GHz
195.13	1536.41	12.5 GHz
195.14	1536.31	12.5 GHz
195.15	1536.22	12.5/50 GHz
195.16	1536.12	12.5 GHz
195.18	1536.02	12.5 GHz
195.19	1535.92	12.5 GHz
195.2	1535.82	12.5/50/100 GHz
195.21	1535.72	12.5 GHz
195.23	1535.63	12.5 GHz
195.24	1535.53	12.5 GHz
195.25	1535.43	12.5/50 GHz
195.26	1535.33	12.5 GHz
195.28	1535.23	12.5 GHz

Table 41: DWDM Module Wavelengths (Continued)

Frequency (THz)	Wavelength (nm)	Offset (GHz)
195.29	1535.13	12.5 GHz
195.3	1535.03	12.5/50/100 GHz
195.31	1534.94	12.5 GHz
195.33	1534.84	12.5 GHz
195.34	1534.74	12.5 GHz
195.35	1564.64	12.5/50 GHz
195.36	1534.55	12.5 GHz
195.38	1534.45	12.5 GHz
195.39	1534.35	12.5 GHz
195.4	1534.25	12.5/50/100 GHz
195.41	1534.15	12.5 GHz
195.43	1534.05	12.5 GHz
195.44	1533.96	12.5 GHz
195.45	1533.86	12.5/50 GHz
195.46	1533.76	12.5 GHz

Table 41: DWDM Module Wavelengths (Continued)

Frequency (THz)	Wavelength (nm)	Offset (GHz)
195.48	1533.66	12.5 GHz
195.49	1533.56	12.5 GHz
195.5	1533.47	12.5/50/100 GHz
195.51	1533.37	12.5 GHz
195.53	1533.27	12.5 GHz
195.54	1533.17	12.5 GHz
195.55	1533.07	12.5/50 GHz
195.56	1532.98	12.5 GHz
195.58	1532.88	12.5 GHz
195.59	1532.78	12.5 GHz
195.6	1532.68	12.5/50/100 GHz
195.61	1532.58	12.5 GHz
195.63	1532.49	12.5 GHz
195.64	1532.39	12.5 GHz
195.65	1532.29	12.5/50 GHz

Table 41: DWDM Module Wavelengths (*Continued*)

Frequency (THz)	Wavelength (nm)	Offset (GHz)
195.66	1532.19	12.5 GHz
195.68	1532.09	12.5 GHz
195.69	1532	12.5 GHz
195.7	1531.9	12.5/50/100 GHz
195.71	1531.8	12.5 GHz
195.73	1531.7	12.5 GHz
195.74	1531.61	12.5 GHz
185.75	1531.51	12.5/50 GHz
185.76	1531.41	12.5 GHz
195.78	1531.31	12.5 GHz
195.79	1531.21	12.5 GHz
195.8	1531.12	12.5/50/100 GHz
195.81	1531.02	12.5 GHz
195.83	1530.92	12.5 GHz
195.84	1530.82	12.5 GHz

Table 41: DWDM Module Wavelengths (*Continued*)

Frequency (THz)	Wavelength (nm)	Offset (GHz)
195.85	1530.73	12.5/50 GHz
195.86	1530.63	12.5 GHz
195.88	1530.53	12.5 GHz
195.89	1530.43	12.5 GHz
195.9	1530.33	12.5/50/100 GHz
195.91	1530.34	12.5 GHz
195.93	1530.24	12.5 GHz
195.94	1530.04	12.5 GHz
195.95	1529.94	12.5/50 GHz
195.96	1529.85	12.5 GHz
195.98	1529.75	12.5 GHz
195.99	1529.65	12.5 GHz
196	1529.55	12.5/50/100 GHz
196.01	1529.46	12.5 GHz
196.03	1529.36	12.5 GHz

Table 41: DWDM Module Wavelengths (Continued)

Frequency (THz)	Wavelength (nm)	Offset (GHz)
196.04	1529.26	12.5 GHz
196.05	1529.16	12.5/50 GHz
196.06	1529.07	12.5 GHz
196.08	1528.97	12.5 GHz
196.09	1528.87	12.5 GHz
196.1	1528.77	12.5/50/100 GHz

PTX10K-LC1105 Line Card

IN THIS SECTION

- [Overview | 133](#)
- [Network Ports | 134](#)
- [Power and Status LEDs | 134](#)
- [Port Status and Activity LEDs | 135](#)

Overview

The PTX10K-LC1105 line card is designed to provide secure Ethernet communication across high-speed links. The card consists of thirty 28-Gbps QSFP+ Pluggable Solution (QSFP28) ports that are Media Access Control Security (MACsec) capable. The ports support speeds of 100 Gbps or 40 Gbps and you can configure the port speed through the CLI. See [Figure 58 on page 134](#).

The PTX10K-LC1105 line card runs Juniper Networks Junos OS for PTX Series software on Juniper Networks JNP10K-LC1105 hardware. The PTX10K-LC1105 line card is supported on Junos OS Release 17.4R1-S1 and later.

Figure 58: PTX10K-LC1105 Port Panel

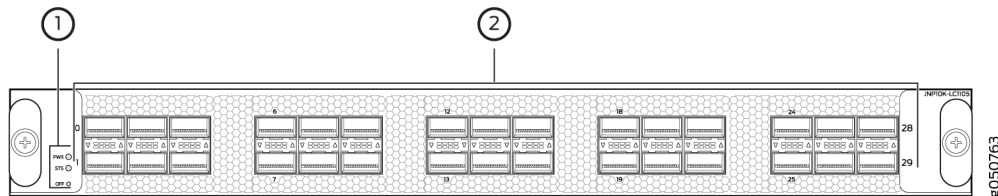

1– Power LED (**PWR**), status LED (**STS**), and offline/online (**OFF**) button

2– Network ports

Network Ports

Each of the 30 QSFP28 ports can operate as:

- 100-Gigabit Ethernet ports when you use QSFP28 optical transceivers.
- 40-Gigabit Ethernet ports when you use QSFP+ optical transceivers.

On the PTX10K-LC1105, the ports are enabled by default.

Power and Status LEDs

The two LEDs to the left of the network ports indicate the power (**PWR**) and status (**STS**) for the line card. See [Table 42 on page 134](#) and [Table 43 on page 135](#).

Table 42: Power LED

Color	State	Description
Unlit	Off	There is no power to the line card.
Green	On steadily	The line card has power.

Table 42: Power LED (Continued)

Color	State	Description
Yellow or amber	Blinking	The line card has a power fault.

Table 43: Status LED

Color	State	Description
Unlit	Off	The line card is offline or disabled.
Green	On steadily	The line card is online.
Yellow or amber	On steadily	The line card is booting.
	Blinking	The line card has a fault condition or alarm.
	Slow blink or blip	The beacon function is enabled.

Port Status and Activity LEDs

Each QSFP28 port has a bicolored up or down LED indicator that shows port status and link activity. See [Figure 59 on page 135](#) and [Table 44 on page 136](#).

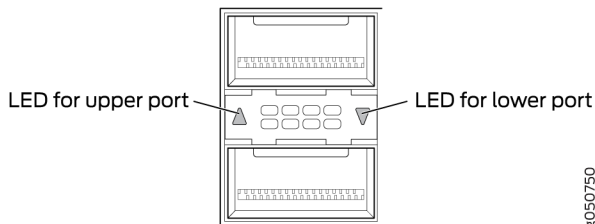
Figure 59: Indicators for QSFP28 Ports on PTX10K-LC1105 Line Cards

8050750

Table 44: Network Port Status and Activity LEDs on a PTX10K-LC1105 Line Card

Color	State	Description
Unlit	Off	The port is administratively disabled, there is no power, the link is down, or a transceiver is not present.
Green	On steadily	A link is established but there is no activity.
	Blinking	A link is up and there is activity.
Yellow or amber	Slow blink or blip	The beacon function is enabled on the port.
	Blinking	A single LED blinking indicates an interface fault.

SEE ALSO

| *Install and Remove PTX10008 Line Card Components*

QFX10000-60S-6Q Line Card

IN THIS SECTION

- [Hardware Features | 137](#)
- [Port Groups | 138](#)
- [Channelization of 40-Gigabit Ethernet Ports | 139](#)
- [Using Copper and Fiber SFP Transceivers | 140](#)
- [SFP+ Status and Activity LEDs | 141](#)
- [QSFP+ and QSFP28 Status and Activity LEDs | 142](#)

Hardware Features

The QFX10000-60S-6Q line card consists of 60 small form-factor pluggable plus (SFP+) ports that support 10-Gbps or 1-Gbps port speed, 2 dual-speed QSFP28 ports that support either 40-Gbps or 100-Gbps port speed, and 4 QSFP+ ports that support 40-Gbps port speed. All of the QSFP and SFP+ ports are configured to 10-Gbps by default. The QSFP28 ports are configured as 40-Gbps speed ports by default, but port **60** and port **64** are dual-speed ports and can be configured to support either 10-Gigabit Ethernet or 40-Gigabit Ethernet optical transceivers. Ports **60** and **64** can also be configured to support 100-Gigabit Ethernet optical transceivers. See the [Hardware Compatibility Tool](#) for details of supported optical transceivers. See [Figure 60 on page 137](#).

The QFX10000-60S-6Q line card is supported on Junos OS Release 19.1R1 and later.

NOTE: Junos OS Release 19.1R1 does not support 1-Gigabit Ethernet on the 10-Gigabit Ethernet SFP+ ports.

Figure 60: QFX10000-60S-6Q Port Panel

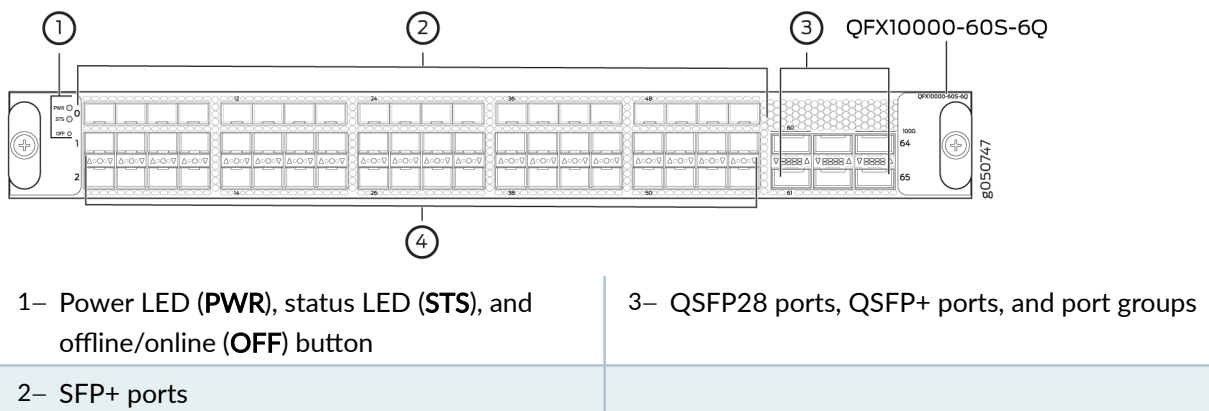

Each QSFP28 port (**60** and **64**) controls a port group and can be configured as a:

- 100-Gigabit Ethernet port by using QSFP28 optical transceivers. The interface speeds are configured by port group. When a QSFP28 transceiver is inserted into one of the QSFP28 ports marked with a fine black line above the port (**60** or **64**) and the port is configured for 100-Gigabit Ethernet, the two adjacent ports are disabled and the QSFP28 port is enabled for 100-Gigabit Ethernet. When port **60** is configured for 100-Gbps, ports **61** and **62** are disabled; when port **64** is configured for 100-Gbps, ports **63** and **65** are disabled.
- 40-Gigabit Ethernet port by using QSFP+ optical transceivers. The default speed is 10 Gbps.

- 10-Gigabit Ethernet port by using breakout cables and attached optical transceivers. When configured for channelization, the system converts the 40-Gigabit Ethernet port into four independent 10-Gigabit Ethernet ports (or channels). Use the `set chassis fpc fpc-slot-numbers pic pic-slot-number port port-number speed speed` command to change the port speed.

Each QSFP+ port (**61**, **62**, **63**, and **65**) is part of a port group and is controlled by one of the associated QSFP28 ports (**60** or **64**). If a QSFP28 port operates at 40-Gbps speed, then each of the QSFP+ ports can be configured as a:

- 40-Gigabit Ethernet port by using QSFP+ optical transceivers. The default speed is 10 Gbps.
- 10-Gigabit Ethernet port by using breakout cables with attached optical transceivers. When configured for channelization, the system converts the 40-Gigabit Ethernet port into four independent 10-Gigabit Ethernet ports (or channels). Use the `set chassis fpc fpc-slot-number pic pic-slot-number port port-number speed speed` command to change the port speed.

Each SFP+ port (**0** through **59**) can be configured as a 10-Gigabit Ethernet port by using SFP+ optical transceivers. The default speed is 10 Gbps.

You can install copper SFP transceivers only on ports located in the lower two SFP+ port rows (at the bottom). Copper SFP transceivers are only supported on the bottom two SFP+ rows. The copper SFP transceivers (1000BASE-T) are limited to these rows because they are physically larger than optical SFP transceivers (1000BASE-X). Stacking copper SFP transceivers in all three rows causes internal damage to the line card. Optical SFP transceivers can be stacked and used in all SFP+ ports, **0** through **59**.

Any of the 66 ports **0** through **65** can be configured as either uplink or access ports. The ports are enabled by default, and the default configuration adds the ports to the default VLAN.

Port Groups

The six combination ports of QSFP28 and QSFP+ can operate either as six independent 40-Gigabit Ethernet ports or as two port groups. The first port group is controlled by QSFP28 port **60** and administratively bundled with QSFP+ ports **61** and **62**. The second port group is controlled by QSFP28 port **64** and administratively bundled with QSFP+ ports **63** and **65**. To enable the port group, insert a 100-Gigabit Ethernet transceiver into the QSFP28 port and configure the port as a 100-Gbps port. Junos OS enables the QSFP28 port at 100-Gbps speed and disables the two QSFP+ ports bundled in

the port group. [Figure 61 on page 139](#) shows the location of QSFP28 ports and port groups for the QFX10000-60S-6Q. [Table 45 on page 139](#) shows the available combinations for the ports.

Figure 61: QFX10000-60S-6Q Port Groups

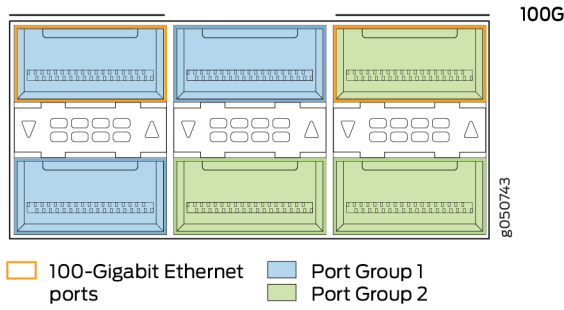

Table 45: QFX10000-60S-6Q Port Mapping

Port Number	4X10-Gigabit Ethernet	4X10-Gigabit Channelized Port Group	40-Gigabit Ethernet	100-Gigabit Ethernet	100-Gigabit Ethernet Disables
60	✓	✓	✓	✓	61, 62
61	✓		✓	-	-
62	✓		✓	-	-
63	✓	✓	✓	-	-
64	✓		✓	✓	63, 65
65	✓		✓	-	-

Channelization of 40-Gigabit Ethernet Ports

Channelization from a 40-Gigabit Ethernet port into four independent 10-Gigabit Ethernet ports is supported on the QSFP28 and QSFP+ ports. Channelization to 50-Gbps or 25-Gbps speed is not

supported on the 100-Gigabit Ethernet QSFP28 port. All ports in the port group are channelized when port **60** or port **64** is channelized. Ports cannot be channelized individually.

To channelize a 40-Gbps port to four independent 10-Gbps ports (or channels), use the `set chassis fpc fpc-slot-number pic pic-slot-number port port-number channel-speed speed` command. For example, to channelize ports **60** through **62** for a line card in slot **6**:

```
[edit chassis fpc 6 pic 1]
user@router# set port 60 speed 10g
```

Review your configuration and issue the `commit` command.

If you want to return the port to the default, delete the speed statement from the configuration at the `[chassis fpc 6 pic 1 port port-number]` hierarchy level and commit the configuration. The network port is reset to the default 40-Gigabit Ethernet interface.

```
[edit chassis fpc 6 pic 1]
user@router# delete port 60 speed 10g
```

Using Copper and Fiber SFP Transceivers

When you configure the 10-Gigabit Ethernet ports **0** to **59** as 1-Gigabit Ethernet ports, you can use optical fiber SFP transceivers in any of the ports. However, copper SFP transceivers are restricted to the lower two rows. See [Figure 62 on page 140](#).

Figure 62: Supported Placement for Copper and Fiber SFP+ Transceivers

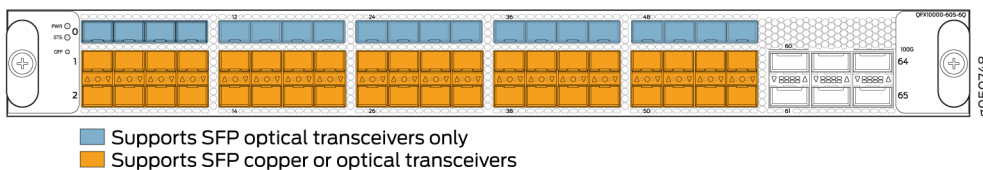

CAUTION: Stacking three copper SFP transceivers in a column can cause damage to the line card.

Because 1-Gbps copper SFP transceivers are physically larger than optical SFP transceivers, there is insufficient room for three copper SFP transceivers to be stacked. Use the top row only for optical SFP transceivers. You can stack copper transceivers in the bottom two rows. Ports are arranged belly-to-

belly. Stacking three SFP transceivers in a column can damage the line card. For the recommended configuration, see [Figure 63 on page 141](#).

Figure 63: Belly-to-Belly SFP Transceivers

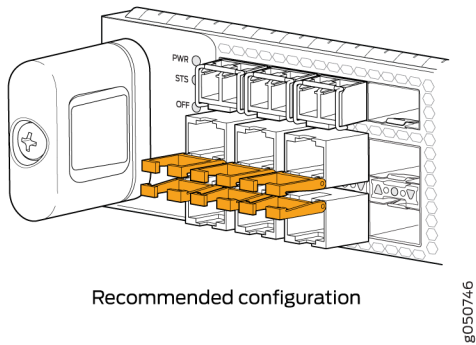

SFP+ Status and Activity LEDs

All status and activity LEDs for the SFP+ ports are located between the second and third rows of SFP+. The up arrow, circle, and down arrow indicate the row of the status. A bicolor LED indicates the status and activity. See [Figure 64 on page 141](#) and [Table 46 on page 142](#).

Figure 64: SFP+ Port Indicators and Status LEDs on a QFX10000-60S-6Q Line Card

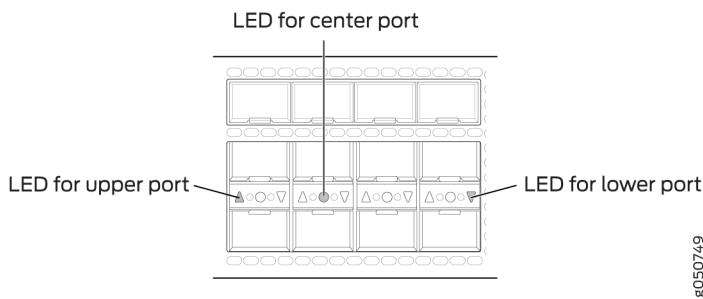

- An up arrow indicates the first row.
- A circle indicates the second row.
- A down arrow indicates the third row.

Table 46: Network Port Status and Activity LEDs for SFP+ Ports on a QFX10000-60S-6Q Line Card

Color	State	Description
Unlit	Off	The port is administratively disabled, there is no power, the link is down, or a transceiver is not present.
Green	On steadily	A link is established.
Yellow or Amber	Slow blink, or blip	The beacon function is enabled on one or more sub-channels.
	Blinking	The interface has a fault condition.

QSFP+ and QSFP28 Status and Activity LEDs

All QSFP+ and QSFP28 ports have an up or down indicator for each port and four bicolored LEDs that show port status and link activity based on whether or not the port is configured for channelization. See [Table 47 on page 143](#).

Figure 65: LED Indicators on QSFP+ and QSFP28 Ports on QFX10000-60S-6Q Line Card

Table 47: QSFP+ and QSFP28 Network Port Status and Activity LEDs

Color	State	Description
Unlit	Off	The port is administratively disabled, there is no power, the link is down, or a transceiver is not present. All sub-channels are disabled.
Green	On steadily	A link is established. When channelized, all sub-channels are up. When not channelized, it indicates no activity.
Yellow or Amber	On steadily	At least one channel link is up, but not all channels are up.
	Slow blink, or blip	The beacon function is enabled on one or more sub-channels.
	Blinking	One or more sub-channels has a fault condition.

PTX10016 Line-Card LEDs

All PTX10016 line cards have two bicolored (green and amber) LEDs. See [Figure 66 on page 143](#).

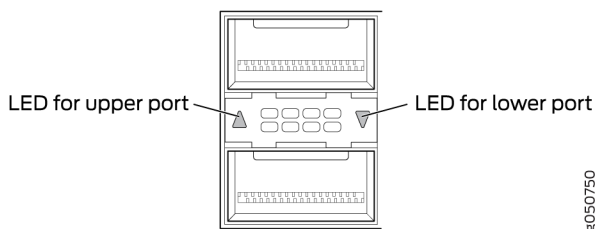
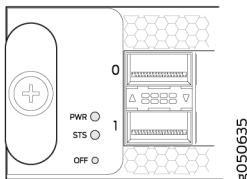
Figure 66: Line-Card LEDs

[Table 48 on page 144](#) describes the functions of the line-card LEDs.

Table 48: Line Card LEDs

Label	Color	State	Description
PWR	Unlit	Off	The line card is not receiving power.
	Green	On steadily	The line card is receiving power.
	Yellow	Blinking	The line card has a power error, such as insufficient power.
STS	Unlit	Off	The line card is offline.
	Green	On steadily	The line card is online and functioning normally.
	Green	Blinking	The beacon feature is enabled on the line card.
	Yellow	On steadily	The line card is booting.
	Yellow	Blinking	The line card is detecting an error.

Taking a Line Card Offline

The offline/online button is recessed below the faceplate directly below the status (STS) LED. You can take any of the PTX10016 line cards online or offline using either of these two methods:

- Press the **OFF** button with a non-conductive pin tool, such as a toothpick, until the **STS** LED goes out (about 5 seconds).
- Issue the CLI command:

```
user@host> request chassis pic fpc-slot fpc-slot pic-slot pic-slot offline
```

RELATED DOCUMENTATION

[PTX10016 Field-Replaceable Units | 22](#)

[Install and Remove PTX10016 Line Card Components | 311](#)

2

CHAPTER

Site Planning, Preparation, and Specifications

[PTX10016 Site Preparation Overview | 147](#)

[PTX10016 Power Planning | 160](#)

[PTX10016 Transceiver and Cable Specifications | 188](#)

[PTX10016 Console and Management Cable Specifications and Pinouts | 194](#)

PTX10016 Site Preparation Overview

IN THIS SECTION

- [PTX10016 Site Preparation Checklist | 147](#)
- [PTX10016 Environmental Requirements and Specifications | 149](#)
- [General Site Guidelines | 150](#)
- [PTX10016 Site Electrical Wiring Guidelines | 151](#)
- [PTX10016 Rack Requirements | 152](#)
- [PTX10016 Clearance Requirements for Airflow and Hardware Maintenance | 155](#)
- [PTX10016 Chassis Physical Specifications | 156](#)

The following sections describe the guidelines, the specifications, and the requirements to prepare the site for installing a PTX10016 router.

PTX10016 Site Preparation Checklist

The checklist in [Table 49 on page 147](#) summarizes the tasks you need to perform when preparing a site for a PTX10016 installation.

Table 49: Site Preparation Checklist

✓	Item or Task	For More Information
	Environment	
□	Verify that environmental factors such as temperature and humidity do not exceed router tolerances.	"PTX10016 Environmental Requirements and Specifications" on page 149
	Power	

Table 49: Site Preparation Checklist (Continued)

✓	Item or Task	For More Information
<input type="checkbox"/>	Measure the distance between external power sources and the router installation site.	
<input type="checkbox"/>	Calculate the power consumption and requirements.	"PTX10016 Power Planning" on page 160
Rack		
<input type="checkbox"/>	Verify that your rack meets the minimum requirements for the installation of the router.	"PTX10016 Rack Requirements" on page 152
<input type="checkbox"/>	Plan rack location, including required space clearances.	"PTX10016 Clearance Requirements for Airflow and Hardware Maintenance" on page 155
<input type="checkbox"/>	Secure the rack to the floor and building structure.	
Cables		
<input type="checkbox"/>	<p>Acquire cables and connectors:</p> <ul style="list-style-type: none"> • Determine the number of cables needed based on your planned configuration. • Review the maximum distance allowed for each cable. Choose the length of cable based on the distance between the hardware components being connected. 	<p>The list of supported transceivers for the PTX10016 line cards is located at https://apps.juniper.net/hct/product/#prd=PTX10016.</p>
<input type="checkbox"/>	Plan the cable routing and management.	

PTX10016 Environmental Requirements and Specifications

The PTX10016 router must be installed in a four-post rack. It must be housed in a dry, clean, well-ventilated, and temperature-controlled environment.

Follow these environmental guidelines:

- The site must be as dust-free as possible, because dust can clog air intake vents and filters, reducing the efficiency of the router cooling system.
- Maintain ambient airflow for normal router operation. If the airflow is blocked or restricted, or if the intake air is too warm, the router might overheat, leading to the router temperature monitor shutting down the device to protect the hardware components.

[Table 50 on page 149](#) provides the required environmental conditions for normal router operation.

Table 50: PTX10016 Environmental Tolerances

Description	Tolerance
Altitude	No performance degradation up to 6562 feet (2000 meters).
Relative humidity	<p>Normal operation ensured in relative humidity range of 5% through 90%, noncondensing.</p> <ul style="list-style-type: none"> • Short-term operation ensured in relative humidity range of 5% through 93%, noncondensing. <p>NOTE: As defined in NEBS GR-63-CORE, Issue 3, short-term events can be up to 96 hours in duration but not more than 15 days per year.</p>

Table 50: PTX10016 Environmental Tolerances (*Continued*)

Description	Tolerance
Temperature	<ul style="list-style-type: none"> • Normal operation ensured in temperature range of 32° F through 104° F (0° C through 40° C). • Nonoperating storage temperature in shipping container: –40° F through 158° F (–40° C through 70° C). • Short-term operation: –5° C to + 50° C. <p>NOTE: As defined in NEBS GR-63-CORE, Issue 3, short-term events can be up to 96 hours in duration but not more than 15 days per year.</p>
Seismic	Designed to comply with Zone 4 earthquake requirements per NEBS GR-63-CORE, Issue 3.

NOTE: Install PTX10016 router only in restricted-access areas, such as dedicated equipment rooms and equipment closets, in accordance with Articles 110-16, 110-17, and 110-18 of the National Electrical Code, ANSI/NFPA 70.

General Site Guidelines

Efficient device operation requires proper site planning and maintenance and proper layout of the equipment, rack or cabinet (if used), and wiring closet.

To plan and create an acceptable operating environment for your device and prevent environmentally caused equipment failures:

- Keep the area around the chassis free from dust and conductive material, such as metal flakes.
- Follow prescribed airflow guidelines to ensure that the cooling system functions properly and that exhaust from other equipment does not blow into the intake vents of the device.
- Follow the prescribed electrostatic discharge (ESD) prevention procedures to prevent damaging the equipment. Static discharge can cause components to fail completely or intermittently over time.

- Install the device in a secure area, so that only authorized personnel can access the device.

SEE ALSO

[Prevention of Electrostatic Discharge Damage | 388](#)

PTX10016 Site Electrical Wiring Guidelines

[Table 51 on page 151](#) describes the factors you must consider while planning the electrical wiring at your site.



CAUTION: It is particularly important to provide a properly grounded and shielded environment and to use electrical surge-suppression devices.

Table 51: Site Electrical Wiring Guidelines

Site Wiring Factor	Guideline
Signaling limitations	<p>To ensure that signaling functions optimally:</p> <ul style="list-style-type: none"> • Install wires correctly. Improperly installed wires can emit radio interference. • Do not exceed the recommended distances or pass wires between buildings. The potential for damage from lightning strikes increases if wires exceed recommended distances or if wires pass between buildings. • Shield all conductors. The electromagnetic pulse (EMP) caused by lightning can damage unshielded conductors and destroy electronic devices.

Table 51: Site Electrical Wiring Guidelines (Continued)

Site Wiring Factor	Guideline
Radio frequency interference (RFI)	<p>To reduce or eliminate the emission of RFI from your site wiring:</p> <ul style="list-style-type: none"> • Use twisted-pair cable with a good distribution of grounding conductors. • Use a high-quality twisted-pair cable with one ground conductor for each data signal when applicable, if you must exceed the recommended distances.
Electromagnetic compatibility (EMC)	<p>Provide a properly grounded and shielded environment and use electrical surge-suppression devices.</p> <p>Strong sources of electromagnetic interference (EMI) can cause the following damage:</p> <ul style="list-style-type: none"> • Destruction of the signal drivers and receivers in the device. • Electrical hazards as a result of power surges conducted over the lines into the equipment. <p>TIP: If your site is susceptible to problems with EMC, particularly from lightning or radio transmitters, you might want to seek expert advice.</p>



WARNING: The intrabuilding port(s) of the equipment or subassembly is suitable for connection to intrabuilding or unexposed wiring or cabling only. The intrabuilding port(s) of the equipment or subassembly **MUST NOT** be metallically connected to interfaces that connect to the OSP or its wiring. These interfaces are designed for use as intrabuilding interfaces only (Type 2 or Type 4 ports as described in GR-1089-CORE), and require isolation from the exposed OSP cabling. The addition of primary protectors is not sufficient protection to connect these interfaces metallically to OSP wiring

PTX10016 Rack Requirements

The PTX10016 router chassis are designed to be installed in four-post racks.

Rack requirements consist of:

- Rack type
- Rack mount kit hole spacing
- Rack size and strength
- Rack connection to the building structure

[Table 52 on page 153](#) provides the rack requirements and specifications for the PTX10016 routers.

Table 52: Rack Requirements for the PTX10016

Rack Requirement	Guidelines
Rack type: four-post	<p>Use a four-post rack that provides bracket holes or hole patterns spaced at 1 U (1.75 in. or 4.45 cm) increments and that meets the size and strength requirements to support the weight.</p> <p>A U is the standard rack unit defined in <i>Cabinets, Racks, Panels, and Associated Equipment</i> (document number EIA-310-D) published by the Electronics Industry Association.</p> <p>You can stack two PTX10016 routers at the bottom of the four-post rack if:</p> <ul style="list-style-type: none"> • The rack is 42 U or greater. • The rack meets the strength requirements to support the weight. • The facility can provide adequate power and cooling.
Rack mount kit hole spacing	<p>The holes in the rack mount kit are spaced at 1 U (1.75 in. or 4.45 cm), so that the router can be mounted in any rack that provides holes spaced at that distance.</p>

Table 52: Rack Requirements for the PTX10016 (Continued)

Rack Requirement	Guidelines
Rack size and strength	<ul style="list-style-type: none"> • Ensure that the rack complies with the standards for a 19-in. wide rack as defined in <i>Cabinets, Racks, Panels, and Associated Equipment</i> (document number EIA-310-D) published by the Electronics Industry Association. • Use one of the standard rack lengths as defined in the four-part <i>Equipment Engineering (EE); European telecommunications standard for equipment practice</i> (document numbers ETS 300 119-1 through 119-4) published by the European Telecommunications Standards Institute (http://www.etsi.org). <ul style="list-style-type: none"> • 23.62 in. (600 mm) • 30.0 in. (762 mm) • 31.5 in. (800 mm) • Ensure that the rack rails are spaced widely enough to accommodate the router chassis' external dimensions. The outer edges of the flange extend the chassis width to 19 in. (48.26 cm). • Ensure that the rack is strong enough to support the weight of the router and cabling. • Ensure that the spacing of rails and adjacent racks allows for proper clearance around the router and rack. See "PTX10016 Clearance Requirements for Airflow and Hardware Maintenance" on page 155
Rack connection to building structure	<ul style="list-style-type: none"> • Secure the rack to the building structure. • If earthquakes are a possibility in your geographical area, secure the rack to the floor. • Secure the rack to the ceiling as well as wall or floor for maximum stability.

PTX10016 Clearance Requirements for Airflow and Hardware Maintenance

When planning the site for a PTX10016 router installation, you must allow sufficient clearance around the installed chassis for cooling and maintenance. See [Figure 67 on page 155](#) and [Figure 68 on page 156](#) for the top view of the clearance for the PTX10016.

Figure 67: Clearance Requirements for Airflow and Hardware Maintenance for a PTX10016 Chassis

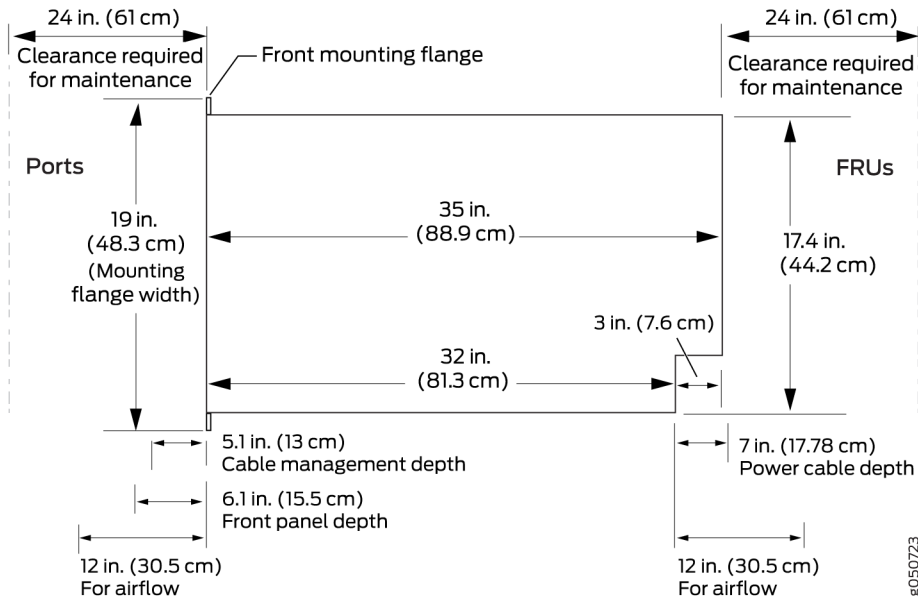
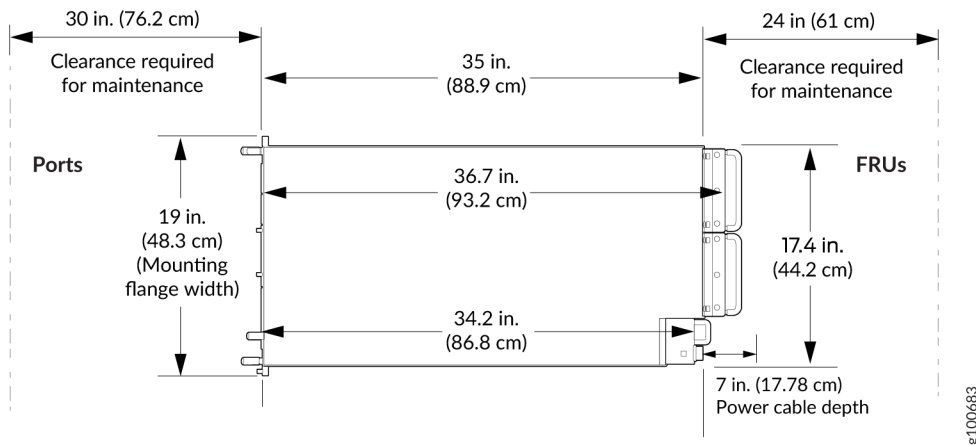

Figure 68: Clearance Requirements for Airflow and Hardware Maintenance for a PTX10016 with JNP10008-FAN2



Follow these guidelines:

- For the cooling system to function properly, the airflow around the chassis must be unrestricted. See ["PTX10016 Cooling System and Airflow" on page 30](#) for more information about the airflow through the chassis.
- If you are mounting a PTX10016 in a rack with other equipment, ensure that the exhaust from other equipment does not blow into the intake vents of the chassis.
- Leave at least 24 in. (61 cm) both in front of and behind the PTX10016 for service personnel to remove and install hardware components. To be NEBS GR-63 compliant, allow at least 30 in. (76.2 cm) in front of the rack and 24 in. (61 cm) behind the rack.

SEE ALSO

[Rack-Mounting and Cabinet-Mounting Warnings | 371](#)

PTX10016 Chassis Physical Specifications

The PTX10016 modular chassis is a rigid sheet-metal structure that houses the field-replaceable units (FRUs). You can mount up to two PTX10016 chassis in a standard 19-in. 4-post rack (42 U) rack, provided the rack can handle the combined weight and there is adequate power and cooling. [Table 53 on page 157](#) summarizes the physical specifications of the chassis. See [Figure 69 on page 159](#).

NOTE: Line card specifications are without optics or the cable management system.

Table 53: PTX10016 Physical Specifications

Description	Net Weight	Height	Width	Depth
Chassis, spare	220 lb (99.79 kg)	36.6 in. (92.96 cm)	17.4 in. (44.2 cm) NOTE: The outer edges of the chassis flange extend the width to 19 in. (48.3 cm).	35 in. (88.9 cm) 42.4 in. (107.7 cm) with EMI door
Chassis base AC configuration	522 lb (236.78 kg)	36.6 in. (92.96 cm)	17.4 in. (44.2 cm) NOTE: The outer edges of the chassis flange extend the width to 19 in. (48.3 cm).	35 in. (88.9 cm)
Chassis redundant AC configuration	596 lb (270.34 kg)	36.6 in. (92.96 cm)	17.4 in. (44.2 cm) NOTE: The outer edges of the chassis flange extend the width to 19 in. (48.3 cm).	35 in. (88.9 cm)

Table 53: PTX10016 Physical Specifications (Continued)

Description	Net Weight	Height	Width	Depth
Chassis redundant DC configuration	591 lb (268.07 kg)	36.6 in. (92.96 cm)	17.4 in. (44.2 cm) NOTE: The outer edges of the chassis flange extend the width to 19 in. (48.3 cm).	35 in. (88.9 cm)
PTX10K-LC1101 Line Card	27 lb (12.2 kg)	1.89 in. (4.8 cm)	17.2 in. (43.7 cm)	20.54 in. (52.2 cm)
PTX10K-LC1102 Line Card	22.6 lb (10.2 kg)	1.89 in. (4.8 cm)	17.2 in. (43.7 cm)	20.54 in. (52.2 cm)
PTX10K-LC1104 Line Card	31 lb (14.06 kg)	1.89 in. (4.8 cm)	17.2 in. (43.7 cm)	20.54 in. (52.2 cm)
PTX10K-LC1105 Line Card	28.5 lb (12.9 kg)	1.89 in. (4.8 cm)	17.2 in. (43.7 cm)	20.54 in. (52.2 cm)
QFX10000-60S-6 Q Line Card	21.4 lb (9.7 kg)	1.89 in. (4.8 cm)	17.2 in. (43.7 cm)	20.54 in. (52.2 cm)

Figure 69: Front View of PTX10016

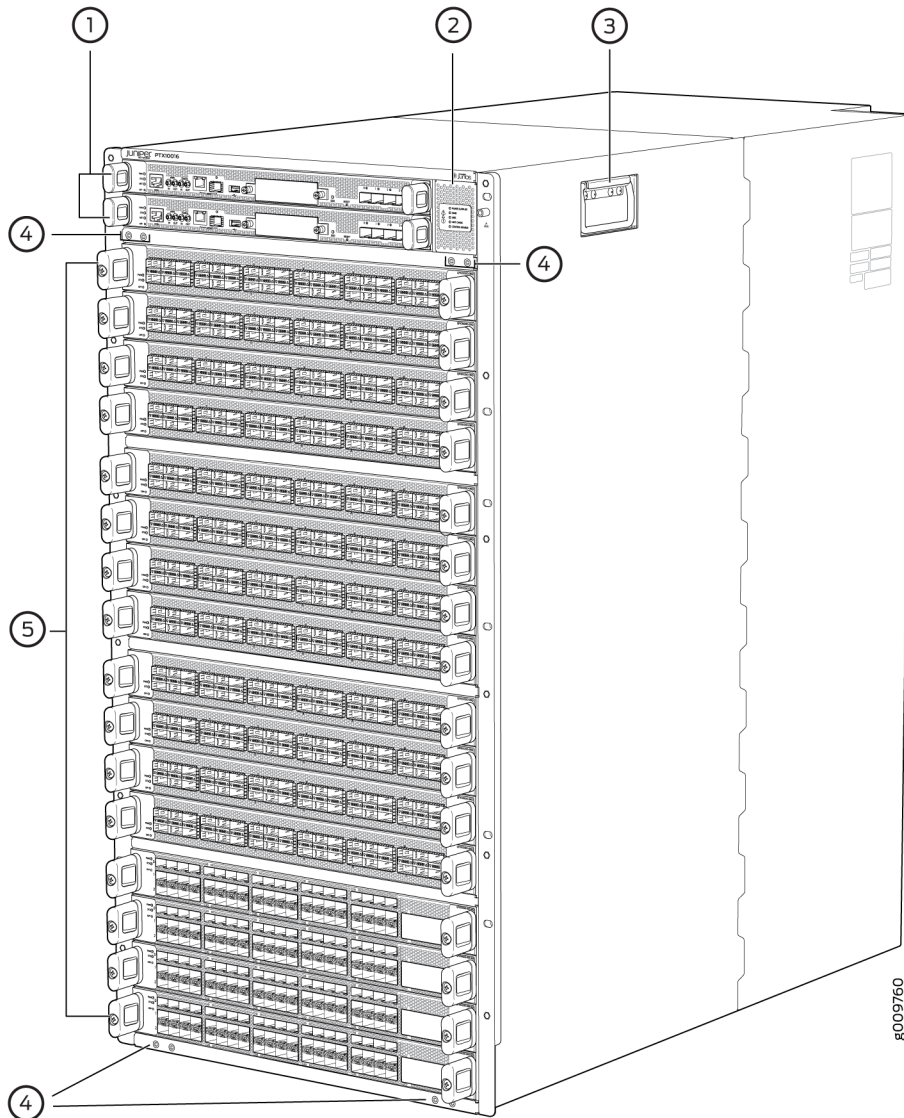

1– Routing and Control Boards (RCBs)

4– Mounting holes for front panel

2– Status panel

5– Line cards

3– Handles



WARNING: The handles on each side of the chassis facilitate the fine-tune positioning of the chassis on the base brackets. Do not use the handles to lift the chassis, even when the chassis is empty. See ["Mount a PTX10016 in a Four-Post Rack Using a Mechanical Lift"](#) on page 213 for instructions for properly moving a loaded chassis.

SEE ALSO

[PTX10016 Components and Configurations | 15](#)

[PTX10016 Cooling System and Airflow | 30](#)

RELATED DOCUMENTATION

[General Safety Guidelines and Warnings | 363](#)

[Rack-Mounting and Cabinet-Mounting Warnings | 371](#)

[Mount a PTX10016 in a Four-Post Rack Using a Mechanical Lift | 213](#)

PTX10016 Power Planning

IN THIS SECTION

- [Power Requirements for PTX10016 Components | 161](#)
- [Calculate Power Requirements for a PTX10016 Router | 162](#)
- [JNP10K-PWR-AC Power Specifications | 172](#)
- [JNP10K-PWR-AC2 Power Specifications | 173](#)
- [PTX10016 Power Cables Specifications | 174](#)
- [JNP10K-PWR-DC Power Specifications | 184](#)
- [JNP10K-PWR-DC2 Power Specifications | 185](#)
- [PTX10016 Grounding Cable and Lug Specifications | 187](#)

Use the information to calculate the power consumption for the PTX10016 and plan your configuration's power requirements.

Power Requirements for PTX10016 Components

Table 54 on page 161 lists the power requirements for different hardware components of a PTX10016 router under typical voltage conditions and optics. For power requirements for chassis configurations, see "Calculate Power Requirements for a PTX10016 Router" on page 162.

Table 54: Power Requirements for PTX10016 Components

Components	Description	Power Requirements (Watts)		
		At 25° C for all systems	At 40° C for systems running Junos OS Evolved	At 55° C for systems running standard Junos OS
JNP10016-SF	PTX10016 standard SIB	510 W	593 W	675 W
JNP10016-FAN	PTX10016 standard fan tray	475 W	-	975 W at maximum fan speed
JNP10K-RE0	PTX10016 standard RCB	50 W	75 W	100 W
JNP10K-RE1	PTX10016 enhanced RCB	100 W	138 W	175 W
PTX10K-LC1101	PTX10016 30-port QSFP28 line card	890 W	1020 W	1150 W
PTX10K-LC1102	PTX10016 36-port QSFP+ line card	520 W	598 W	675 W

Table 54: Power Requirements for PTX10016 Components (*Continued*)

Components	Description	Power Requirements (Watts)		
		At 25° C for all systems	At 40° C for systems running Junos OS Evolved	At 55° C for systems running standard Junos OS
PTX10K-LC1104	PTX10016 coherent DWDM line card	900 W	975 W	1050 W
PTX10K-LC1105	PTX10016 30-port MACsec QSSP28 line card	950 W	1100 W	1250 W
QFX10000-60S-6 Q	PTX10016 60-port SFP+ and 6-port QSFP+ line card	365 W	410 W	465 W

Calculate Power Requirements for a PTX10016 Router

IN THIS SECTION

- [How to Calculate the Power Consumption of Your PTX10016 Configuration | 163](#)
- [How to Calculate the Number of Power Supplies Required for Your PTX10016 Configuration | 167](#)

Use the information in this topic to calculate power requirements of your PTX10016 configuration and the number of power supplies required for different PTX10016 router configurations.



CAUTION: To ensure adequate power and to avoid raising a power alarm, we recommend that you maintain $n + 1$ power supplies in your router at all times. Replace failed power supplies immediately to prevent unexpected failures.

If a new line card is installed in an operational router, power management does not power on the line card if the increased power demand exceeds the total available power, including redundant power. If redundant power is used to power on the line card, a minor alarm is raised, which becomes a major alarm in five minutes if the condition is not corrected.

NOTE: The calculations in this topic represent the maximum power requirements that you need to budget for your PTX10016 router configuration. The actual power consumption of your router will be less than the calculated results shown here and will vary based on the hardware and software configuration of your router, the amount of traffic passing through the line cards, and environmental variables such as room temperature.

Before you begin these calculations:

- Ensure you understand the different router configurations. ["PTX10016 Components and Configurations" on page 15.](#)
- Ensure that you know the power requirements of different router components. See ["Power Requirements for PTX10016 Components" on page 161.](#)

This topic describes these tasks:

How to Calculate the Power Consumption of Your PTX10016 Configuration

Use the following procedure to determine the maximum power you need to supply to the router. To calculate maximum system power consumption, you first determine the combined maximum internal power requirements of all the router components and then divide this result by the power supply output power.



CAUTION: To ensure adequate power and to avoid raising a power alarm, we recommend that you maintain $n + 1$ power supplies in your router at all times. Replace failed power supplies immediately to prevent unexpected failures.

If a new line card is installed in an operational router, power management does not power on the line card if the increased power demand exceeds the total available power, including redundant power. If redundant power is used to power on the line

card, a minor alarm is raised, which becomes a major alarm in five minutes if the condition is not corrected.

NOTE: The calculations in this topic represent the maximum power requirements that you need to budget for your PTX10016 router configuration. The actual power consumption of your router will be less than the calculated results shown here and will vary based on the hardware and software configuration of your router, the amount of traffic passing through the line cards, and environmental variables such as room temperature.

To calculate maximum system power consumption:

1. Determine the maximum power consumption of the base chassis components (that is, the components other than the line cards). Use *Table 2* if your router is configured as either for the standard base, or the redundant configuration.

Table 55: Chassis Power Consumption for Standard Configurations

Chassis Component	Base Configuration	Redundant Configuration
Fan tray	1950 W	1950 W
RCB	100 W	200 W
Switch Interface Board (SIB)	3125 W	3750 W
Total	5175 W	5900 W

2. Calculate the maximum internal power consumption of the entire router by adding in the power requirements of each line card. See *Table 3* for a chart of the power needed for line cards.

Table 56: Line Card Power Consumption

Number of Line Cards	PTX10K-LC1101	PTX10K-LC1102	PTX10K-LC1104	PTX10K-LC1105
1	1150 W	675 W	1050 W	1250 W

Table 56: Line Card Power Consumption (Continued)

Number of Line Cards	PTX10K-LC1101	PTX10K-LC1102	PTX10K-LC1104	PTX10K-LC1105
2	2300 W	1350 W	2100 W	2500 W
3	3450 W	2025 W	3150 W	3750 W
4	4600 W	2700 W	4200 W	5000 W
5	5750 W	3375 W	—	6250 W
6	6900 W	4050 W	—	7500 W
7	8050 W	4725 W	—	8750 W
8	9200 W	5400 W	—	10000 W
9	10350 W	6050 W	—	11250 W
10	11500 W	6750 W	—	12500 W
11	12650 W	7425 W	—	13750 W
12	13800 W	8100 W	—	15000 W
13	14950 W	8775 W	—	16250 W
14	16100 W	9450 W	—	17500 W*
15	17250 W*	10125 W	—	18750 W*

Table 56: Line Card Power Consumption (Continued)

Number of Line Cards	PTX10K-LC1101	PTX10K-LC1102	PTX10K-LC1104	PTX10K-LC1105
16	18400 W*	10800 W	—	20000 W*

NOTE: *In a redundant DC configuration, a maximum of 14 PTX10K-LC1101 or 13 PTX10K-LC1105 line cards are supported.

NOTE: The PTX10K-LC1104 line card is designed to comply with NEBS regulations on the PTX10016 Packet Transport Router when these routers are used in typical configurations. In a typical configuration, a PTX10016 router supports up to 16 line cards, with up to four PTX10K-LC1104 line cards in any of the 16 slots.

NOTE: To comply with EMC regulations, you must also install front panel on the PTX10016 chassis. See "[Install the Front Door on a PTX10016 Router](#)" on page 216.

For example, for a PTX10016 with six PTX10K-LC1102 and five PTX10K-LC1101 line cards, the maximum power consumption is:

= 6 (power consumed by PTX10K-LC1102 in watts) + 5 (power consumed by PTX10K-LC1101 line cards in watts)

= 6 (650 W) + 5 (1150 W)

= (4050 W + 5750 W)

= 9800 W

3. Add the power consumption from Step 1 and the total line card consumption from Step 2.

To continue from the previous example, add the wattage from five PTX10K-LC1102 line cards and three PTX10K-LC1101 cards to a redundant configuration.

(9800 W) + (5900 W)

= 15700 W required

How to Calculate the Number of Power Supplies Required for Your PTX10016 Configuration

Use this procedure to calculate the number of power supplies required by your router configuration. The minimum power configuration for PTX10016 routers is three power supplies. However, using the calculated minimum power configuration does not prevent the system from raising a power alarm. To ensure you do not log power alarms, you must configure your router for $n+1$ power supplies.

To calculate the number of power supplies required for your minimum router configuration:

1. Determine the power available from the power supplies. [Table 57 on page 167](#) shows the power available for installed power supplies.

Table 57: Total Power Available

Power Supply Module Models	With Three Power Supplies	With Four Power Supplies	With Five Power Supplies	With Six Power Supplies	With Seven Power Supplies	With Eight Power Supplies	With Nine Power Supplies	Ten Power Supplies (redundancy only)
JNP10K-PWR-AC	8100 W	10,800 W	13,500 W	16,200 W	18,900 W	21,600 W	24,300 W	—
JNP10K-PWR-AC2 dual feed, high power (30-A) setting	16,500 W	22,000 W	27,500 W	33,000 W	38,500 W	44,000 W	49,500 W	—

Table 57: Total Power Available (Continued)

Power Supply Module Models	With Three Power Supplies	With Four Power Supplies	With Five Power Supplies	With Six Power Supplies	With Seven Power Supplies	With Eight Power Supplies	With Nine Power Supplies	Ten Power Supplies (redundancy only)
JNP10K-PWR-AC2 single feed, high power (30-A) setting	15,000 W	20,000 W	25,000 W	30,000 W	35,000 W	40,000 W	45,000 W	—
JNP10K-PWR-AC2, dual feed, low power (20-A) setting	9,000 W	12,000 W	15,000 W	18,000 W	21,000 W	24,000 W	27,000 W	—
JNP10K-PWR-AC2, single feed, low power (20-A) setting	8,100 W	10,800 W	13,500 W	16,200 W	18,900 W	21,600 W	24,300 W	—

Table 57: Total Power Available (Continued)

Power Supply Module Models	With Three Power Supplies	With Four Power Supplies	With Five Power Supplies	With Six Power Supplies	With Seven Power Supplies	With Eight Power Supplies	With Nine Power Supplies	Ten Power Supplies (redundancy only)
JNP10K-PWR-DC	—	—	12,500 W	15,000 W	17,500 W	20,000 W	22,500 W	—
JNP10K-PWR-DC2 dual feed, high power (80-A) setting	—	—	27,500 W	33,000 W	38,500 W	44,000 W	49,500 W	—
JNP10K-PWR-DC2 dual feed, low power (60-A) setting	—	—	22,000 W	26,400 W	30,800 W	35,200 W	39,600 W	—

Table 57: Total Power Available (Continued)

Power Supply Module Models	With Three Power Supplies	With Four Power Supplies	With Five Power Supplies	With Six Power Supplies	With Seven Power Supplies	With Eight Power Supplies	With Nine Power Supplies	Ten Power Supplies (redundancy only)
JNP10K-PWR-DC2 single feed, high power (80-A) setting	—	—	13,750 W	16,500 W	19,250 W	22,000 W	24,750 W	—
JNP10K-PWR-DC2 single feed, low power (60-A) setting	—	—	11,000 W	13,200 W	15,400 W	17,600 W	19,800 W	—

NOTE: The HVAC/HVDC power supply, JNP10K-PWR-AC2, has a set of DIP switches on the faceplate that allows you to configure the power supply for either high power (30 A) or low power (20 A) input mode. If any JNP10K-PWR-AC2. power supply is set to 20 A, then the power budget for all power supplies installed in the system becomes 20 A, regardless if other power supplies are set at 30 A. This design is to prevent overloading of the power supply that is set to 20 A. See [Table 11 on page 52](#) for details on setting the DIP switches.

- Determine the total power required for your configuration with line cards installed. The total power available to the chassis is calculated by dividing the wattage needed by the power rating, and then rounding up.

In the previous examples, we calculated that a PTX10016 AC system would require 15700 W with five PTX10K-LC1102 and three PTX10K-LC1101 line cards. In this example, we calculate the total power available for this configuration:

$$= (15700 \text{ W}) / (2700 \text{ W})$$

$$= 5.81$$

Round up the result to 6 JNP10K-PWR-AC power supplies. A base configuration would require an additional power supply; a redundant AC system would have sufficient power supplies.

3. Calculate how much power the power supplies need. To determine the power required, multiply the number of power supplies by the power supply wattage and divide by the efficiency of the power supply. The efficiency rate accounts for the loss of energy within the power supply and is 89 percent for power supplies running in PTX10016 routers.

For example if you have an AC system with six power supplies:

$$= 6 (2700 \text{ W}) / (\text{efficiency rating})$$

$$= (16200 \text{ W}) / (0.89)$$

$$= 18202 \text{ W}$$

[Table 58 on page 171](#) shows how much power needs to be supplied for various configurations.

Table 58: Total Power Available with Efficiency

Number of Power Supplies	AC	DC
3	9102 W	
4	12135 W	
5	15169 W	
6	18202 W	
7	21236 W	

Table 58: Total Power Available with Efficiency (Continued)

Number of Power Supplies	AC	DC
8	24270 W	
9	27304 W	25281 W
10 (for redundancy only)		

JNP10K-PWR-AC Power Specifications

PTX10008 and PTX10016 redundant-configuration routers can use either AC or DC power supplies; base-configuration routers are AC only. You can run the JNP10K-PWR-AC power supply only in JNP10008-SF fabric systems.

[Table 59 on page 172](#) lists the power specifications for the AC power supply (JNP10K-PWR-AC) used in a PTX10008 or PTX10016 chassis.

Table 59: Power Specifications for a JNP10K-PWR-AC Power Supply

Item	Specifications
AC input voltage	Operating range: 200–240 VAC
AC input line frequency	50–60 Hz
AC input current rating	16 A
AC output power	2700 W



CAUTION: Use a 2-pole circuit breaker rated at 25 A in the building installation and the system, or as per local electrical code.

Table 60 on page 173 shows the physical specifications for an AC power supply.

Table 60: Physical Specifications for a JNP10K-PWR-AC Power Supply

Specification	Value
Height	3.5 in. (8.89 cm)
Width	3.6 in. (9.14 cm)
Depth	14.4 in. (36.58 cm)
Weight	6.8 lb (3.08 kg)

JNP10K-PWR-AC2 Power Specifications

PTX10008 and PTX10016 redundant-configuration routers can use either AC or DC power supplies; base-configuration routers are AC only. The JNP10K-PWR-AC2 power supply supports AC, HVAC, and HVDC.

Table 61 on page 173 lists the power specifications for the AC power supply (JNP10K-PWR-AC) used in a PTX10008 and PTX10016 chassis.

Table 61: Power Specifications for a JNP10K-PWR-AC2 Power Supply

Item	Specifications
AC input voltage	180–305 VAC
DC input voltage	190–410 VDC
Input current rating	28.5 A
DC output power	12.3 V, 5500 W with dual feed and 5000 W with single feed

Table 62 on page 174 shows the physical specifications for a JNP10K-PWR-AC2 power supply.

Table 62: Physical Specifications for a JNP10K-PWR-AC2 Power Supply

Specification	Value
Height	3.5 in. (8.89 cm)
Width	3.6 in. (9.14 cm)
Depth	15.1 in. (38.35 cm)
Weight	11.4 lb (5.17 kg)

PTX10016 Power Cables Specifications

IN THIS SECTION

- [JNP10K-PWR-AC Power Cable Specifications | 175](#)
- [JNP10K-PWR-AC2 Power Cable Specifications | 178](#)
- [JNP10K-PWR-AC2 Power Cable Specifications for 30-A Input | 181](#)

Most sites distribute power through a main conduit that leads to frame-mounted power distribution panels, one of which can be located at the top of the rack that houses the router. An AC power cord connects each power supply to the power distribution panel.

NOTE: In North America, AC power cords must not exceed 15 feet (approximately 4.5 meters) in length, to comply with National Electrical Code (NEC) Sections 400-8 (NFPA 75, 5-2.2) and 210-52 and Canadian Electrical Code (CEC) Section 4-010(3). The cords shipped with the router to North America and Canada are in compliance.

PTX10016 AC, high-voltage alternating current (HVAC), and high-voltage direct current (HVDC) power supplies have specific cord requirements. Use the following sections to determine the cable requirements based on the model of your power supply and any mode settings:

- For JNP10K-PWR-AC, see ["JNP10K-PWR-AC Power Cable Specifications" on page 175](#)
- For JNP10K-PWR-AC2, with 20-A input, see ["JNP10K-PWR-AC2 Power Cable Specifications" on page 178](#)
- For JNP10K-PWR-AC2 with 30-A input, see ["JNP10K-PWR-AC2 Power Cable Specifications for 30-A Input" on page 181](#)

JNP10K-PWR-AC Power Cable Specifications

Each JNP10K-PWR-AC power supply has two independent 16 A rated AC inlets on the faceplate.

Each detachable AC power cord for is 8 feet (approximately 2.5 meters) long. The coupler end of the appliance cord inserts into the AC appliance inlet on the faceplate of the AC power supply. The coupler type is C19 as described by the International Electrotechnical Commission (IEC) standard 60320. The plug end of the power cord fits into the power source outlet that is standard for your geographical location.

[Table 63 on page 175](#) lists the AC power cord specifications for JNP10K-PWR-AC for various countries and regions.

Table 63: AC Power Cord Specifications for JNP10K-PWR-AC Power Supplies

Country/Region	Electrical Specifications	Plug Standards	Juniper Model Number	Graphic
Argentina	250 VAC, 16 A, 50 Hz	IRAM Type RA/ 3/20	CBL-EX-PWR- C19-AR	 8050615
Australia	250 VAC, 15 A, 50 Hz	AS/NZS 3112 Type SAA/3/15	CBL-EX-PWR- C19-AU	 8027262

Table 63: AC Power Cord Specifications for JNP10K-PWR-AC Power Supplies (Continued)



Country/Region	Electrical Specifications	Plug Standards	Juniper Model Number	Graphic
Brazil	250 VAC, 16 A, 50 Hz	NBR 14136: 2002 Type BR/3/20	CBL-EX-PWR- C19-BR	 #050616
China	250 VAC, 16 A, 50 Hz	GB 1002 Type PRC/3/16	CBL-EX-PWR- C19-CH	 #021263
Europe (except Italy, Switzerland, and United Kingdom)	250 VAC, 16 A, 50 Hz	CEE (7) VII Type VIIG	CBL-EX-PWR- C19-EU	 #021264
India	250 AC, 16 A, 50 Hz	SABS 164/1:1992 Type ZA/3	CBL-EX-PWR- C19-SA	 #021271
Israel	250 AC, 16 A, 50 Hz	SI 32/1971 Type IL/3	CBL-EX-PWR- C19-IL	 #021265
Italy	250 VAC, 16 A, 50 Hz	CEI 23-16 Type I/ 3/16	CBL-EX-PWR- C19-IT	 #021266
Japan	250 VAC, 16 A, 60 Hz	NEMA 6-20 Type N6/20	CBL-EX-PWR- C19-JP (default)	 #021267

Table 63: AC Power Cord Specifications for JNP10K-PWR-AC Power Supplies (Continued)

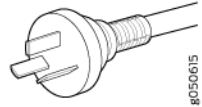
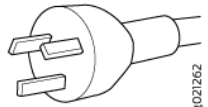

Country/Region	Electrical Specifications	Plug Standards	Juniper Model Number	Graphic
	250 VAC, 16 A, 60 Hz	NEMA L6-20P Type NEMA Locking	CBL-EX-PWR- C19-JPL	 #021268
Korea	250 VAC, 16 A, 50 Hz	CEE (7) VII Type VIIG	CBL-EX-PWR- C19-KR	 #021264
North America	250 VAC, 16 A, 60 Hz	NEMA 6-20 Type N6/20	CBL-EX-PWR- C19-US (default)	 #021267
	250 VAC, 16 A, 60 Hz	NEMA L6-20P Type NEMA Locking	CBL-EX-PWR- C19-USL	 #021268
South Africa	250 VAC, 16 A, 50 Hz	SABS 164/1:1992 Type ZA/3	CBL-EX-PWR- C19-SA	 #021289
Switzerland	250 VAC, 16 A, 50 Hz	SEV 5934/2 Type 23G	CBL-EX-PWR- C19-SZ	 #050617

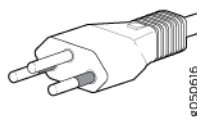
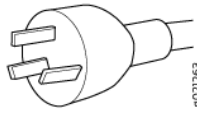
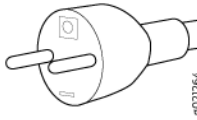
Table 63: AC Power Cord Specifications for JNP10K-PWR-AC Power Supplies (*Continued*)

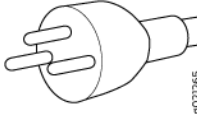
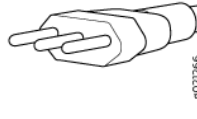
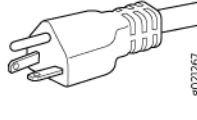
Country/Region	Electrical Specifications	Plug Standards	Juniper Model Number	Graphic
United Kingdom	250 VAC, 13 A, 50 Hz	BS 1363/A Type BS89/13	CBL-EX-PWR- C19-UK	 8021271
Worldwide (other)	250 VAC, 16 A, 50 Hz	EN 60320-2-2/1	CBL-EX-PWR- C19-C20	 8050751

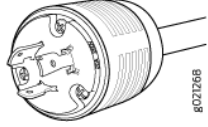
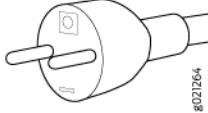
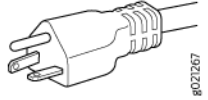
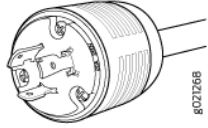
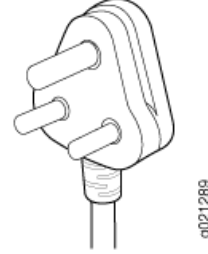

CAUTION: It is important to connect both input feeds of the JNP10K-PWR-AC2 power supply to AC mains before loading the system with power.

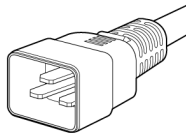

CAUTION: Use a 2-pole circuit breaker rated at 25 A in the building installation and the system, or as per local electrical code.

JNP10K-PWR-AC2 Power Cable Specifications

The JNP10K-PWR-AC2 power supply operates in two modes:

- 30-A input with 5500-W output

"[JNP10K-PWR-AC2 Power Cable Specifications for 30-A Input](#)" on page 181 shows cables and connectors for 30-A input.

- 20-A input with 3000-W output

[Table 64 on page 179](#) shows cables appropriate for 20-A input.



WARNING: Do not run JNP10K-PWR-AC2 power supplies using 16-A or 20-A cables if connected to 30-A input.



CAUTION: You can prevent AC power cables from being exposed to hot air exhaust by always routing the power cables away from the fan trays and power supplies.

NOTE: The cables that we ship are 4.5 m long and come with AWG or mm² wire size depending on your country or region.

Table 64: JNP10K-PWR-AC2 Power Cable Specifications for 20-A Input



Locale	Cord Set Rating	Plug Standards	Spare Juniper Model Number	Graphic
Argentina	16 A, 250 VAC	IRAM 2073 Type RA/3	CBL-JNP-SG4-AR	
Australia and New Zealand	15 A, 250 VAC	AS/NZS 3112	CBL-JNP-SG4-AU	
Brazil	16 A, 250 VAC	NBR 14136 Type BR/3	CBL-JNP-SG4-BR	
China	16 A, 250 VAC	GB2099	CBL-JNP-SG4-CH	
Europe (except Italy, Switzerland, and United Kingdom)	20 A, 250 VAC	CEE 7/7	CBL-JNP-SG4-EU	

Table 64: JNP10K-PWR-AC2 Power Cable Specifications for 20-A Input (Continued)





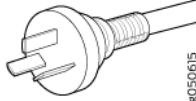
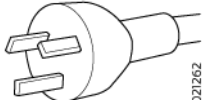

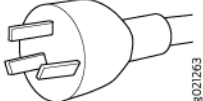
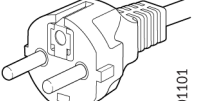
Locale	Cord Set Rating	Plug Standards	Spare Juniper Model Number	Graphic
Great Britain	13 A, 250 VAC,	BS1363	CBL-JNP-SG4-UK	 #021271
India	16 A, 250 VAC	SANS 164/1	CBL-JNP-SG4-SA	 #021270
Israel	16 A, RA, 250 VAC	SI 32/1971 Type IL/3C	CBL-JNP-SG4-IL	 #021265
Italy	16 A, 250 VAC	CEI 23-50	CBL-JNP-SG4-IT	 #021266
North America	20 A, 250 VAC	3-5958P4 to IEC 60320 C20	CBL-JNP-SG4- C20	 #050751
	16 A, 250 VAC	Locking NEMA L6-20P	CBL-JNP-SG4-US- L	 #021268
		NEMA 6-20P	CBL-JNP-SG4-US	 #021267

Table 64: JNP10K-PWR-AC2 Power Cable Specifications for 20-A Input (Continued)

Locale	Cord Set Rating	Plug Standards	Spare Juniper Model Number	Graphic
	15 A, 277 V	NEMA I7-20P	CBL-JNP-SG4-HVAC	 8101100
South Africa	16 A, 250 VAC	SANS 164/1	CBL-JNP-SG4-SA	 81021289
Switzerland	16 A, 250 VAC	CEI 23-50	CBL-JNP-SG4-SZ	 81022666

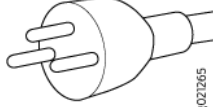
JNP10K-PWR-AC2 Power Cable Specifications for 30-A Input

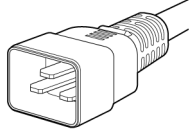
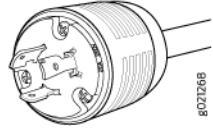
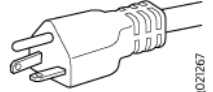
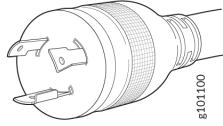
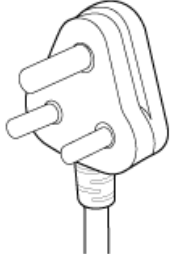
The JNP10K-PWR-AC2 HVAC or HVDC power supplies requires a high current cable assembly when set for 30-A input. One end of the cable has an Anderson APP-400 connector, while the other end of the cable is bare wire. See [Figure 70 on page 182](#) and [Table 65 on page 182](#). These cables are separately orderable and are not shipped automatically with JNP10K-PWR-AC2 orders. An example of the right-angle cable and connector is shown in [Figure 72 on page 184](#).

For connection to AC systems, Juniper provides a cable with either a NEMA 30-A connector (Figure 70 on page 182) or an IEC 330P6W connector (Figure 71 on page 182).

Figure 70: NEMA 30-A Connector

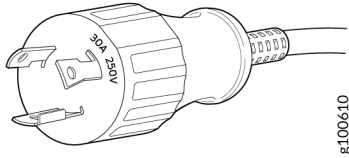

Figure 71: IEC 330P6W Connector

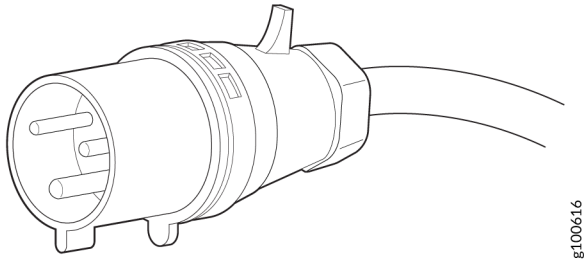

Table 65: 30-A Cabling Options

	Locale	Cord Set Rating	Plug Standards	Connector	Spare Juniper Model Number
HVAC/ HVDC power cord	Any	30-A, 400 VAC	UL 950 and IEC 60950	Anderson/ straight to bare wire	CBL-PWR2-BARE
		30-A, 400 VAC	UL 950 and IEC 60950	Anderson/right- angle to bare wire	CBL-PWR2-BARE- RA
AC power cord	Continental Europe	30-A 250 VAC	UL 950 and IEC332P6	Anderson/right- angle to IEC 332P6	CBL- PWR2-332P6W-RA

Table 65: 30-A Cabling Options (Continued)

	Locale	Cord Set Rating	Plug Standards	Connector	Spare Juniper Model Number
		30-A 250 VAC	UL 950 and IEC332P6	Anderson/straight to IEC332P6	CBL-PWR2-332P6W
	North America	30-A 240 VAC	IEC330P6	Anderson/right-angle to IEC 330P6	CBL-PWR2-330P6W-RA
		30-A 240 VAC	IEC330P6	Anderson/straight to IEC 330P6	CBL-PWR2-330P6W
		30-A 250 VAC	UL 498, CSA	Anderson/right-angle to L6-30P (NEMA-30A)	CBL-PWR2-L6-30P-RA
		30-A 250 VAC	UL 498, IEC5958P4	Anderson/straight to L6-30P (NEMA-30A)	CBL-PWR2-L6-30P

Figure 72: Right-Angle, Bare Cable with Anderson Connector

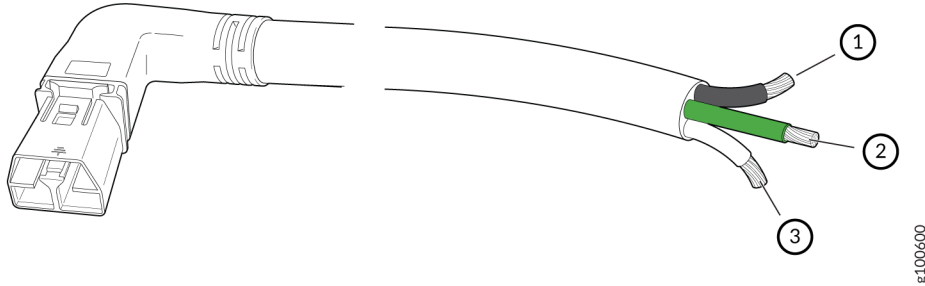

1- Black wire - Return (+)

3- White wire - Neutral

2- Green wire - Ground

JNP10K-PWR-DC Power Specifications

The DC power supply (JNP10K-PWR-DC) is supported only in PTX10008-SF or PTX10016-SF fabric systems. [Table 66 on page 184](#) lists the power specifications for the JNP10K-PWR-DC power supply used in a PTX10008 and PTX10016 modular chassis.

Table 66: Power Specifications for the JNP10K-PWR-DC Power Supply

Item	Specifications
DC input voltage	<ul style="list-style-type: none"> • Minimum operating voltage: -40 VDC • Nominal operating voltage: -48 VDC • Operating voltage range: -40 VDC through -72 VDC
DC input current rating	60 A maximum at nominal operating voltage (-48 VDC) for each input terminal
Output power	2500 W

[Table 67 on page 185](#) shows the physical specifications for a JNP10K-PWR-DC power supply.

Table 67: Physical Specifications of a JNP10K-PWR-DC Power Supply

Specification	Value
Height	3.5 in. (8.89 cm)
Width	3.6 in. (9.14 cm)
Depth	14.4 in. (36.58 cm)
Weight	6 lb (2.72 kg)

JNP10K-PWR-DC2 Power Specifications

HVDC power supplies (JNP10K-PWR-DC2) are supported in only the PTX10008 and PTX10016 redundant configuration. [Table 68 on page 185](#) lists the power specifications for the HVDC power supply used in PTX10008 and PTX10016 routers.

Table 68: Power Specifications for the JNP10K-PWR-DC2 Power Supply

Item	Specifications
DC input voltage	<ul style="list-style-type: none"> • Minimum operating voltage: -40 VDC • Nominal operating voltage: -48 VDC • Operating voltage range: -40 VDC through -72 VDC

Table 68: Power Specifications for the JNP10K-PWR-DC2 Power Supply (Continued)

Item	Specifications
DC input current rating	<ul style="list-style-type: none"> • 76-A maximum at minimum operating voltage (-40 VDC) with 80-A DIP switch setting and 5500-W output load. • 64-A maximum at nominal operating voltage (-48 VDC) with 80-A DIP switch setting and 5500-W output load. • 60-A maximum at minimum operating voltage (-40 VDC) with 60-A DIP switch setting and 4400-W output load. • 50-A maximum at nominal operating voltage (-48 VDC) with 60-A DIP switch setting and 4400-W output load.
Output power	<p>2200 W for low input (60-A) single feed</p> <p>4400 W for low input (60-A) dual feed</p> <p>2750 W for high input (80-A) single feed</p> <p>5500 W for high input (80-A) dual feed</p>

[Table 69 on page 186](#) shows the physical specifications for a JNP10K-PWR-DC2 power supply.

Table 69: Physical Specifications of a JNP10K-PWR-DC2 Power Supply

Specification	Value
Height	3.5 in. (8.89 cm)
Width	3.6 in. (9.14 cm)
Depth	16.05 in. (40.77 cm)
Weight	8.1 lb (3.67 kg)

PTX10016 Grounding Cable and Lug Specifications

You must install the router in a restricted-access location and ensure it is adequately grounded at all times. Proper grounding ensures your router is operating correctly and that it meets safety and electromagnetic interference (EMI) requirements. The PTX10016 modular chassis has a 2-hole protective grounding terminal on the rear of the chassis beneath the power supplies for grounding.

For AC powered systems, you must also use the grounding wire in the AC power cord along with the 2-hole lug ground connection. This tested system meets or exceeds all applicable EMC regulatory requirements with the 2-hole protective grounding terminal.



WARNING: To comply with GR-1089 requirements, all intrabuilding copper cabling used for SFP+, QSFP+, and QSFP28 ports must be shielded and grounded at both ends.



CAUTION: Before router installation begins, a licensed electrician must attach a cable lug to the grounding cables that you supply. See "[Connect a PTX10016 Router to Earth Ground](#)" on page 224. A cable with an incorrectly attached lug can damage the router.

Before connecting the router to earth ground, review the following information:

- Two threaded inserts (PEM nuts) are provided on the lower rear of the chassis for connecting the router to earth ground. The grounding points are spaced at 0.63 in. (16 mm) centers.
- The grounding lug required is a Panduit LCD6-10A-L or equivalent (provided). The grounding lug accommodates 6 AWG (13.3 mm²) stranded wire. If one or more JNP10K-PWR-DC2 power supplies are installed in the chassis and set for high input (80 A), use the Panduit LCD4-14A-L or equivalent (provided). This lug accommodates 4 AWG (21.1mm²) stranded wire. The 4 AWG (21.1 mm²) stranded wire should be rated 90° C, or as permitted by local electrical code.
- The grounding cable that you provide for a PTX10016 must be the same size or heavier than the input wire of each power supply. Minimum recommendations are 6 AWG (13.3 mm²) stranded copper wire, Class B; 90° C wire, or as permitted by local code.

SEE ALSO

[Connect AC Power to the PTX10016 Router | 227](#)

[Connect DC Power to a PTX10016 Router | 228](#)

RELATED DOCUMENTATION

[JNP10K-PWR-AC Power Supply | 47](#)

[JNP10K-PWR-AC2 Power Supply | 50](#)

[JNP10K-PWR-DC Power Supply | 53](#)

[JNP10K-PWR-DC2 Power Supply | 55](#)

PTX10016 Transceiver and Cable Specifications

IN THIS SECTION

- [PTX10016 Optical Transceiver and Cable Support | 188](#)
- [PTX10016 Cable Specifications for Console and Management Connections | 189](#)
- [PTX10016 Fiber Optic Cable Signal Loss, Attenuation, and Dispersion | 190](#)
- [Calculate the Fiber-Optic Cable Power Budget for a PTX10016 Router | 191](#)
- [Calculate the Fiber-Optic Cable Power Margin for a PTX10016 Router | 192](#)

Review fiber-optic cable characteristics and plan the power budget and power margin for fiber-optic cables connected to your device by using the information in the following topics.

PTX10016 Optical Transceiver and Cable Support

You can find information about the pluggable transceivers supported on your Juniper Networks device by using the Hardware Compatibility Tool. In addition to transceiver and connector type, the optical and cable characteristics—where applicable—are documented for each transceiver. The Hardware Compatibility Tool enables you to search by product, displaying all the transceivers supported on that device, or category, by interface speed or type. The list of supported transceivers for the PTX10016 is located at <https://pathfinder.juniper.net/hct/product/#prd=PTX10016>.



CAUTION: If you face a problem running a Juniper Networks device that uses a third-party optic or cable, the Juniper Networks Technical Assistance Center (JTAC) can help

you diagnose the source of the problem. Your JTAC engineer might recommend that you check the third-party optic or cable and potentially replace it with an equivalent Juniper Networks optic or cable that is qualified for the device.

PTX10016 Cable Specifications for Console and Management Connections

[Table 70 on page 189](#) lists the specifications for the cables that connect the PTX10016 router to a management device.

NOTE: The PTX10016 models can be configured with SFP management ports that support 1000BASE-SX transceivers.

Table 70: Cable Specifications for Console and Management Connections for the PTX10016 Routers

Port on PTX10016 Router	Cable Specification	Cable Supplied	Maximum Length	Device Receptacle
Console port	RS-232 (EIA-232) serial cable	One 7-foot (2.13-meter) long RJ-45 patch cable and RJ-45 to DB-9 adapter	2.13 meters	RJ-45
Management port	Category 5 cable or equivalent suitable for 1000BASE-T operation	One 7-foot (2.13-meter) long RJ-45 patch cable	100 meters	RJ-45

SEE ALSO

[Connect a PTX10016 Router to a Management Console | 231](#)

[Connect a PTX10016 Router to a Network for Out-of-Band Management | 230](#)

PTX10016 Fiber Optic Cable Signal Loss, Attenuation, and Dispersion

IN THIS SECTION

- [Signal Loss in Multimode and Single-Mode Fiber-Optic Cables | 190](#)
- [Attenuation and Dispersion in Fiber-Optic Cable | 190](#)

To determine the power budget and power margin needed for fiber-optic connections, you need to understand how signal loss, attenuation, and dispersion affect transmission. The PTX10016 router uses various types of network cables, including multimode and single-mode fiber-optic cables.

Signal Loss in Multimode and Single-Mode Fiber-Optic Cables

Multimode fiber is large enough in diameter to allow rays of light to reflect internally (bounce off the walls of the fiber). Interfaces with multimode optics typically use LEDs as light sources. However, LEDs are not coherent light sources. They spray varying wavelengths of light into the multimode fiber, which reflect the light at different angles. Light rays travel in jagged lines through a multimode fiber, causing signal dispersion. When light traveling in the fiber core radiates into the fiber cladding (layers of lower refractive index material in close contact with a core material of higher refractive index), higher-order mode loss occurs. Together, these factors reduce the transmission distance of multimode fiber compared to that of single-mode fiber.

Single-mode fiber is so small in diameter that rays of light reflect internally through one layer only. Interfaces with single-mode optics use lasers as light sources. Lasers generate a single wavelength of light, which travels in a straight line through the single-mode fiber. Compared to multimode fiber, single-mode fiber has a higher bandwidth and can carry signals for longer distances. It is consequently more expensive.

Attenuation and Dispersion in Fiber-Optic Cable

An optical data link functions correctly provided that modulated light reaching the receiver has enough power to be demodulated correctly. *Attenuation* is the reduction in strength of the light signal during transmission. Passive media components such as cables, cable splices, and connectors cause attenuation. Although attenuation is significantly lower for optical fiber than for other media, it still occurs in both multimode and single-mode transmission. An efficient optical data link must transmit enough light to overcome attenuation.

Dispersion is the spreading of the signal over time. The following two types of dispersion can affect signal transmission through an optical data link:

- Chromatic dispersion, which is the spreading of the signal over time caused by the different speeds of light rays.
- Modal dispersion, which is the spreading of the signal over time caused by the different propagation modes in the fiber.

For multimode transmission, modal dispersion, rather than chromatic dispersion or attenuation, usually limits the maximum bit rate and link length. For single-mode transmission, modal dispersion is not a factor. However, at higher bit rates and over longer distances, chromatic dispersion limits the maximum link length.

An efficient optical data link must have enough light to exceed the minimum power that the receiver requires to operate within its specifications. In addition, the total dispersion must be within the limits specified for the type of link in the Telcordia Technologies document GR-253-CORE (Section 4.3) and International Telecommunications Union (ITU) document G.957.

When chromatic dispersion is at the maximum allowed, its effect can be considered as a power penalty in the power budget. The optical power budget must allow for the sum of component attenuation, power penalties (including those from dispersion), and a safety margin for unexpected losses.

Calculate the Fiber-Optic Cable Power Budget for a PTX10016 Router

Calculate the link's power budget when planning fiber-optic cable layout and distances to ensure that fiber-optic connections have sufficient power for correct operation. The power budget is the maximum amount of power the link can transmit. When you calculate the power budget, you use a worst-case analysis to provide a margin of error, even though all the parts of an actual system do not operate at the worst-case levels.

To calculate the worst-case estimate for the fiber-optic cable power budget (P^B) for the link:

1. Determine values for the link's minimum transmitter power (P_T) and minimum receiver sensitivity (P_R). For example, here, (P_T) and (P_R) are measured in decibels, and decibels are referenced to 1 milliwatt (dBm):

$$P_T = -15 \text{ dBm}$$

$$P_R = -28 \text{ dBm}$$

NOTE: See the specifications for your transmitter and receiver to find the minimum transmitter power and minimum receiver sensitivity.

2. Calculate the power budget (P^B) by subtracting (P_R) from (P_T):

$$-15 \text{ dBm} - (-28 \text{ dBm}) = 13 \text{ dBm}$$

Calculate the Fiber-Optic Cable Power Margin for a PTX10016 Router

Before you begin to calculate the power margin:

- Calculate the power budget. See ["Calculate the Fiber-Optic Cable Power Budget for a PTX10016 Router" on page 191](#).

Calculate the link's power margin when planning fiber-optic cable layout and distances to ensure that fiber-optic connections have sufficient signal power to overcome system losses and still satisfy the minimum input requirements of the receiver for the required performance level. The power margin (P_M) is the amount of power available after attenuation or link loss (LL) has been subtracted from the power budget (P_B).

When you calculate the power margin, you use a worst-case analysis to provide a margin of error, even though all the parts of an actual system do not operate at worst-case levels. A power margin (P_M) greater than zero indicates that the power budget is sufficient to operate the receiver and that it does not exceed the maximum receiver input power. This means the link will work. A (P_M) that is zero or negative indicates insufficient power to operate the receiver. See the specification for your receiver to find the maximum receiver input power.

To calculate the worst-case estimate for the power margin (P_M) for the link:

1. Determine the maximum value for link loss (LL) by adding estimated values for applicable link-loss factors; for example, use the sample values for various factors as provided in [Table 71 on page 192](#) (here, the link is 2 km long and multimode, and the (P_B) is 13 dBm).

Table 71: Estimated Values for Factors Causing Link Loss

Link-Loss Factor	Estimated Link Loss Value	Sample Link Loss (LL) Calculation Values
Higher-order mode losses	Multimode—0.5 dBm	0.5 dBm
	Single-mode—None	0 dBm
Modal and chromatic dispersion	Multimode—None, if product of bandwidth and distance is less than 500 MHz/km	0 dBm

Table 71: Estimated Values for Factors Causing Link Loss (*Continued*)

Link-Loss Factor	Estimated Link Loss Value	Sample Link Loss (LL) Calculation Values
	Single-mode—None	0 dBm
Connector	0.5 dBm	This example assumes five connectors. Loss for five connectors: 5 (0.5 dBm) = 2.5 dBm.
Splice	0.5 dBm	This example assumes two splices. Loss for two splices: 2 (0.5 dBm) = 1 dBm.
Fiber attenuation	Multimode—1 dBm/km	This example assumes the link is 2 km long. Fiber attenuation for 2 km: 2 km (1 dBm/km) = 2 dBm.
	Single-mode—0.5 dBm/km	This example assumes the link is 2 km long. Fiber attenuation for 2 km: 2 km (0.5 dBm/km) = 1 dBm.
Clock Recovery Module (CRM)	1 dBm	1 dBm

NOTE: For information about the actual amount of signal loss caused by equipment and other factors, see your vendor documentation for that equipment.

2. Calculate the (P_M) by subtracting (LL) from (P_B):

$$P_B - LL = P_M$$

$$13 \text{ dBm} - 0.5 \text{ dBm [HOL]} - 5 (0.5 \text{ dBm}) - 2 (0.5 \text{ dBm}) - 2 \text{ km } (1.0 \text{ dBm/km}) - 1 \text{ dB [CRM]} = P_M$$

$$13 \text{ dBm} - 0.5 \text{ dBm} - 2.5 \text{ dBm} - 1 \text{ dBm} - 2 \text{ dBm} - 1 \text{ dBm} = P_M$$

$$P_M = 6 \text{ dBm}$$

The calculated power margin is greater than zero, indicating that the link has sufficient power for transmission. Also, the power margin value does not exceed the maximum receiver input power. Refer to the specifications for your receiver to find the maximum receiver input power.

PTX10016 Console and Management Cable Specifications and Pinouts

IN THIS SECTION

- [Console Port Connector Pinouts for a PTX10016 | 194](#)
- [USB Port Specifications for the PTX10016 Routers | 196](#)
- [Management Port Connector Pinouts for the PTX10016 Router | 196](#)

The following sections describe the console port, the USB port, and the management port connections and specifications.

Console Port Connector Pinouts for a PTX10016

The console port (labeled **CON**) on the Routing and Control Board panel is an RS-232 serial interface that uses an RJ-45 connector to connect to a console management device. The default baud rate for the console port is 9600 baud.

[Table 72 on page 195](#) provides the pinout information for the RJ-45 console connector. An RJ-45 cable and RJ-45 to DB-9 adapter are supplied with the PTX10016 routers.

NOTE: If your laptop or PC does not have a DB-9 plug connector pin and you want to connect your laptop or PC directly to a PTX10016 router, use a combination of the RJ-45 cable and RJ-45 to DB-9 adapter supplied with the device and a USB to DB-9 plug adapter. You must provide the USB to DB-9 plug adapter.

Table 72: Console Port Connector Pinouts for the PTX10016 Series

Pin	Signal	Description
1	RTS output	Request to send
2	DTR output TOD output for PTP applications	Data terminal ready Time of day for Precision Time Protocol (PTP). You can use DTR pins as a TOD universal asynchronous receiver/transmitter (UART) by using breakout cables.
3	TxD output	Transmit data
4	Signal ground	Signal ground
5	Signal ground	Signal ground
6	RxD input	Receive data
7	DCD input TOD output for PTP applications	Data carrier detect Time of day for PTP. You can use DCD pins as a TOD UART by using breakout cables.
8	CTS input	Clear to send

SEE ALSO

| [Connect a PTX10016 Router to a Management Console](#) | 231

USB Port Specifications for the PTX10016 Routers

The following Juniper Networks USB flash drives have been tested and are officially supported for the USB port in the PTX10016 routers:

- RE-USB-1G-S—1-gigabyte (GB) USB flash drive
- RE-USB-2G-S—2-GB USB flash drive
- RE-USB-4G-S—4-GB USB flash drive



CAUTION: Any USB memory product not listed as supported for the PTX10016 routers has not been tested by Juniper Networks. The use of any unsupported USB memory product could expose your device to unpredictable behavior. Juniper Networks Technical Assistance Center (JTAC) can provide only limited support for issues related to unsupported hardware. We strongly recommend that you use only supported USB flash drives.



CAUTION: Remove the USB flash drive before upgrading Junos OS or rebooting a PTX10016 routers. Failure to do so could expose your device to unpredictable behavior.

NOTE: USB flash drives used with the PTX10016 router must support USB 2.0 or later.

SEE ALSO

[Creating an Emergency Boot Device](#)

[Performing a Recovery Installation Using an Emergency Boot Device](#)

Management Port Connector Pinouts for the PTX10016 Router

The 1000BASE-T RJ-45 management ports use an RJ-45 connector to connect a management device for out-of-band management.

[Table 73 on page 197](#) provides the pinout information of the RJ-45 management port connector. An RJ-45 cable is supplied with the PTX10016 router.

Table 73: RJ-45 Management Port Connector Pinouts for the PTX10016 Router

Pin	Signal	Description
1	TRP1+	Transmit/receive data pair 1
2	TRP1-	Transmit/receive data pair 1
3	TRP2+	Transmit/receive data pair 2
4	TRP3+	Transmit/receive data pair 3
5	TRP3-	Transmit/receive data pair 3
6	TRP2-	Transmit/receive data pair 2
7	TRP4+	Transmit/receive data pair 4
8	TRP4-	Transmit/receive data pair 4

SEE ALSO

| [PTX10016 Routing and Control Board LEDs](#) | 72

3

CHAPTER

Initial Installation and Configuration

[PTX10016 Installation Overview | 199](#)

[Unpack the PTX10016 | 200](#)

[Install the Mounting Hardware for a PTX10016 | 210](#)

[Mount a PTX10016 in a Four-Post Rack Using a Mechanical Lift | 213](#)

[Install the Front Door on a PTX10016 Router | 216](#)

[Connect the PTX10016 to Power | 224](#)

[Connect the PTX10016 to External Devices | 229](#)

[Perform the Initial Configuration for the PTX10016 Router | 232](#)

PTX10016 Installation Overview

The PTX10016 is a rigid sheet-metal router-chassis that houses the other hardware components such as Routing and Control Boards (RCBs), Switch Interface Boards (SIBs), power supplies, fan trays, and line cards. The router chassis ships in a cardboard box that has a two-layer wooden pallet base. The router chassis is bolted to the pallet base. You can install a PTX10016 router in a standard 19 in. (483 mm) equipment rack by using the supplied rack mount kit and the flanges that are attached to the chassis.

The steps to install the PTX10016 are:

1. Unpack the router following the instructions in ["Unpack the PTX10016 Shipping Pallet" on page 200](#).
2. Mount the chassis in the rack following the instructions in ["Mount a PTX10016 in a Four-Post Rack Using a Mechanical Lift" on page 213](#).



WARNING: Because of the weight of the chassis, manual mounting is not recommended.

3. Install the line cards following the instructions in ["Install a PTX10016 Line Card" on page 312](#).
4. Connect the chassis to earth ground following the instructions in ["Connect a PTX10016 Router to Earth Ground" on page 224](#).
5. Connect power to the power supplies following either the instructions in ["Connect AC Power to the PTX10016 Router" on page 227](#) or ["Connect DC Power to a PTX10016 Router" on page 228](#).
6. Connect to the network.
 - To connect the router to a network for out-of-band management, follow instructions in ["Connect a PTX10016 Router to a Network for Out-of-Band Management" on page 230](#).
 - To connect the router to a management console, follow instructions in ["Connect a PTX10016 Router to a Management Console" on page 231](#).
7. Configure the router, following the instructions in ["Perform the Initial Configuration for the PTX10016 Router" on page 232](#).
8. Install optional equipment such as the cable management system. See ["Install the PTX10016 Cable Management System" on page 318](#).

RELATED DOCUMENTATION

[PTX10016 Rack Requirements | 152](#)

[PTX10016 Clearance Requirements for Airflow and Hardware Maintenance | 155](#)

[PTX10016 Chassis Lifting Guidelines | 369](#)

Unpack the PTX10016

IN THIS SECTION

- [Unpack the PTX10016 Shipping Pallet | 200](#)
- [Unpack Line Cards, Routing Control Boards, and Switch Interface Boards for the PTX10016 | 203](#)
- [Compare the PTX10016 Order to the Packing List | 204](#)
- [Register Products—Mandatory to Validate SLAs | 210](#)

To unpack the PTX10016 and its components, read the following sections:

Unpack the PTX10016 Shipping Pallet

After you prepare the installation site as described in [Table 49 on page 147](#), you can unpack the router.

NOTE: The chassis is maximally protected inside the shipping box. Do not unpack it until you are ready to begin installation.

Ensure that you have the following parts and tools available to unpack the PTX10016:

- A 13/32-in. (10-mm) open-end or socket wrench to remove the bolts from the shipping pallet
- A box cutter or packing knife to slice open the nylon straps and tape that seal the crate and boxes

The chassis ships in a cardboard box that has a two-layer wooden pallet base with foam cushioning between the layers. The router chassis is bolted to the pallet base.

The shipper has the option to either ship the front panel separately or ship it along with the chassis. If the front panel arrives with the chassis, set aside the front panel box until you are ready to verify the contents of the order.

To unpack the chassis (see [Figure 73](#) on page 201):

Figure 73: Shipping Crate and Accessory Box

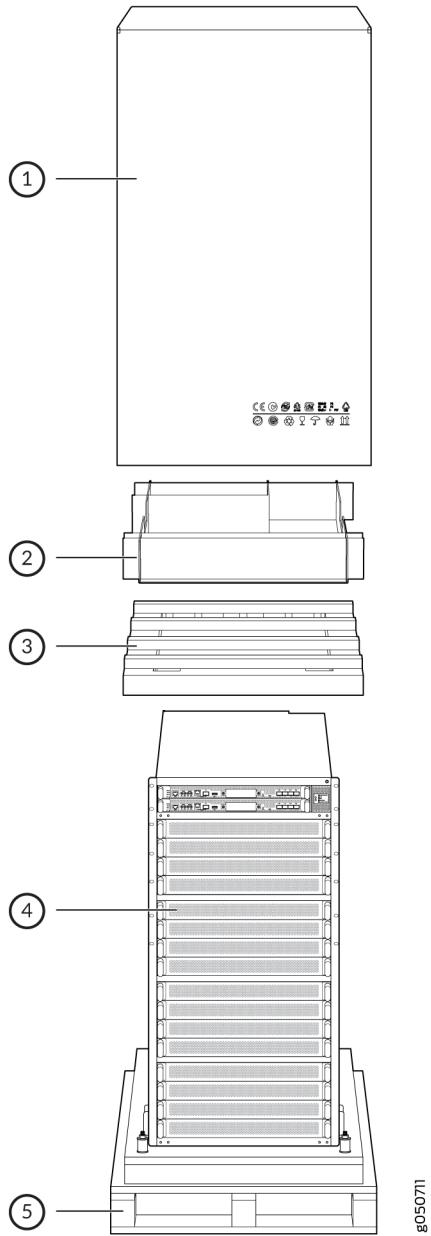

1- Corrugated cover	4- PTX10016 router
2- Accessory box	5- Pallet
3- Foam top	

1. Move the shipping box to a staging area as close to the installation site as possible. While the chassis is bolted to the pallet, you can use a forklift or pallet jack to move the shipping box. Make sure there is enough space to remove components from the chassis.
2. Position the shipping box with the arrows pointing up.
3. Use the box cutter to slice the nylon straps that hold the shipping boxes to the pallet.
4. Lift the shipping box off the chassis.
5. Remove the cardboard accessory box.
6. Remove the foam padding from the top of the box.
7. Remove the plastic cover from the router chassis.
8. Use a 13/32-in. (10-mm) open-end or socket wrench to remove the four sets of bracket bolts that secure the chassis to the shipping pallet (see [Figure 74 on page 202](#)).

Figure 74: Remove the Bracket Bolt

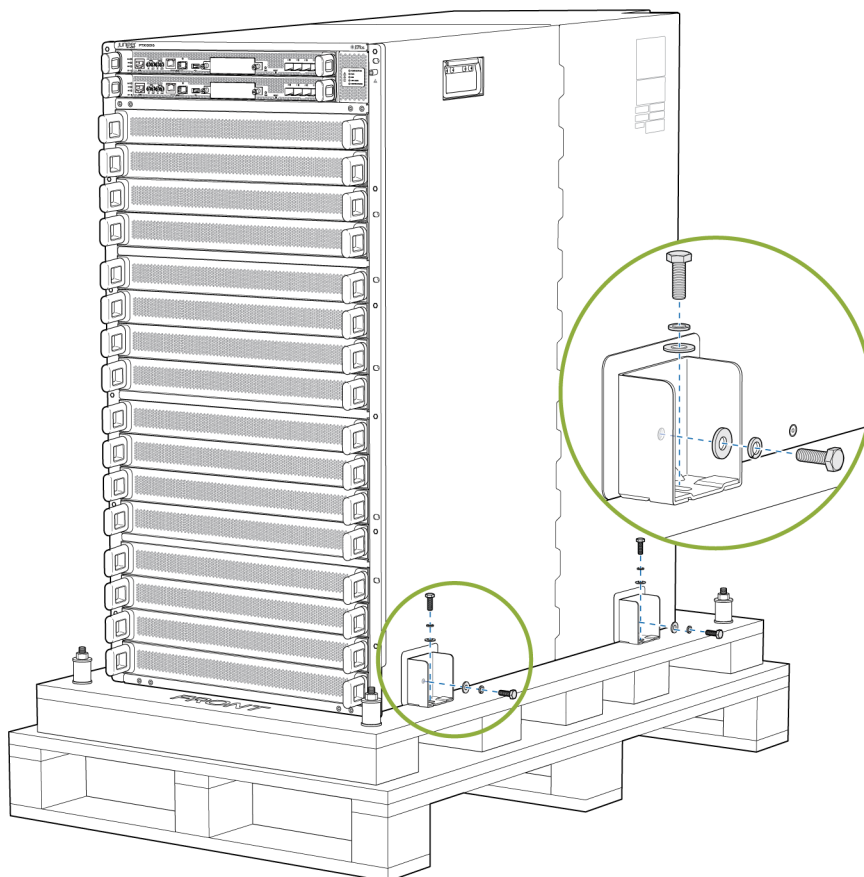

9. Unpack the accessory box and lay out the contents so that they are ready for use.

10. Verify that your order includes all appropriate parts. See ["Compare the PTX10016 Order to the Packing List"](#) on page 204 and for information about base configurations and redundant configurations.
11. Store the shipping brackets and bolts inside the accessory box.
12. Save the shipping box and packing materials in case you need to move or ship the router at a later time.

SEE ALSO

| [Mount a PTX10016 in a Four-Post Rack Using a Mechanical Lift](#) | 213

Unpack Line Cards, Routing Control Boards, and Switch Interface Boards for the PTX10016

Before you unpack a component:

- Ensure that you have taken the necessary precautions to prevent electrostatic discharge (ESD) damage. See ["Prevention of Electrostatic Discharge Damage"](#) on page 388.
- Ensure that you know how to handle and store the component. (See ["How to Handle and Store PTX10016 Line Cards, RCBs, and SIBs"](#) on page 300).

Line cards, additional Routing and Control Boards (RCBs), and additional Switch Interface Boards (SIBs) components are FRUs that are shipped separately from the router chassis. The housing for the RCBs and line cards are rigid sheet-metal structures that house the electronics. SIBs have an exposed printed circuit board (PCB) on one side and sheet metal on the other. All these components are shipped in a cardboard carton, secured with packing material.



CAUTION: The components are maximally protected inside the shipping carton. Do not unpack them until you are ready to install the components in the router chassis.

To unpack an RCB, a SIB, or a line card, (see [Figure 75 on page 204](#)):

1. Move the shipping carton to a staging area as close to the installation site as possible.
2. Position the carton so that the arrows are pointing up.
3. Open the top flaps on the shipping carton.
4. Pull out the packing material that holds the component in place.
5. Remove the component from the antistatic bag.

6. Save the shipping carton and packing materials in case you need to move or ship the RCB, SIB, or line card later.

Figure 75: Unpacking a Line Card

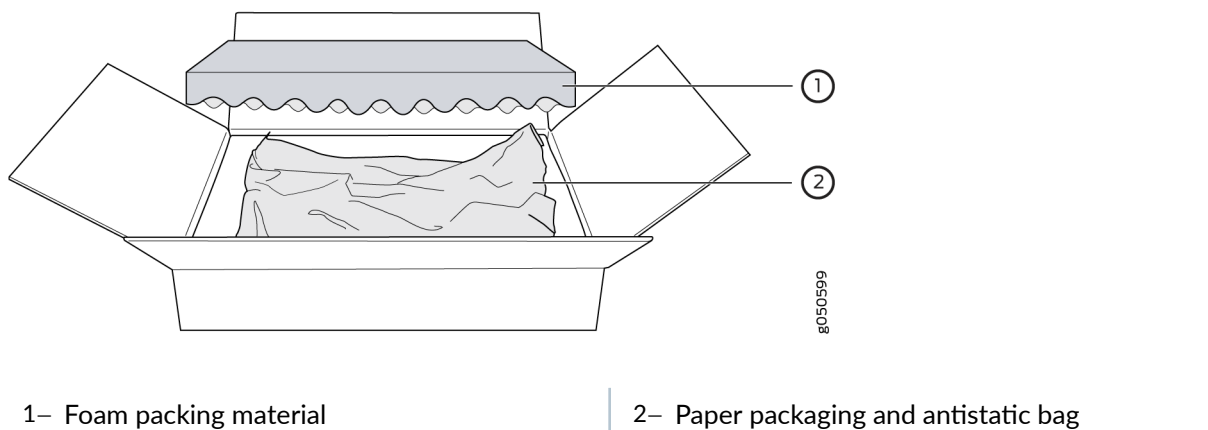

SEE ALSO

[PTX10016 Components and Configurations | 15](#)

Compare the PTX10016 Order to the Packing List

The router chassis shipment includes a packing list. Check the parts you receive in the shipping crate against the items on the packing list. The packing list specifies the part number and description of each part in your order.

If any part on the packing list is missing, contact your customer service representative, or contact Juniper Networks Customer Care from within the U.S. or Canada by telephone at 1-888-314-5822. For international-dial or direct-dial options in countries without toll-free numbers, see <https://www.juniper.net/support/requesting-support.html>.

Items that ship separately from the chassis are:

- Line cards
- Chassis front panel kit (JNP10016-FRNT-PNL or JNP10016-FRPNL1)

NOTE: The kit is a spare part and can ship with the chassis or separately.

- Cable management kit (JLC-CBL-MGMT-KIT)

Use the following procedure to compare the sales order and packing list against the contents of the chassis shipping crate.

1. Determine the configuration. See "[PTX10016 Components and Configurations](#)" on page 15. The parts shipped depend on the configuration you order. Supported configurations are:
 - Base configuration.
 - PTX10016-BASE for AC
 - PTX10016-BASE for DC
 - Premium redundant configuration.
 - PTX10016-PREMIUM for AC
 - PTX10016-PREMIUM for DC
2. Compare premium redundant configuration orders using [Table 74 on page 205](#).

Table 74: Premium Redundant Configuration Order

Component	PTX10016 Quantity
Chassis, including power bus	1
Routing and Control Boards	2
Fan tray controllers <ul style="list-style-type: none"> • JNP10016-FAN-CTRL or • JNP10016-FTC2 	2
Fan trays <ul style="list-style-type: none"> • JNP10016-FAN or • JNP10016-FAN2 	2

Table 74: Premium Redundant Configuration Order (Continued)

Component	PTX10016 Quantity
Power supplies <ul style="list-style-type: none"> • JNP10K-PWR-AC • JNP10K-PWR-AC2 • JNP10K-PWR-DC • JNP10K-PWR-DC2 	10
Switch Interface Boards (SIBs)	6
Covers in the line-card positions	16
Accessory kit (see Table 76 on page 208)	1
Rack mount kit (see Table 77 on page 209)	1
Front panel kit (see Table 78 on page 209)	1
Documentation Roadmap Card	1

3. Compare base configuration orders using [Table 75 on page 206](#).

Table 75: Base Configuration Order

Component	PTX10016 Quantity
Chassis, including power bus	1
RCBs	1
Cover panel, in the RCB slot	1

Table 75: Base Configuration Order (*Continued*)

Component	PTX10016 Quantity
Fan tray controllers	2
Fan trays	2
Power supplies	5
SIBs	5
Cover in a SIB position	1
Covers in the power-supply positions	5
Covers in the line-card positions	16
Dust covers for RCB ports	5 for RE0; 3 for RE1
Accessory kit (see Table 76 on page 208)	1
Rack mount kit (see Table 77 on page 209)	1
Front panel kit, lockable (see Table 78 on page 209)	1
Documentation Roadmap Card	1

4. Compare the contents of the accessory kit with [Table 76 on page 208](#).

Table 76: PTX10016 Accessory Kit

Component	Quantity	
	AC Configurations	DC Configurations
Warranty card	1	1
End User License Agreement (EULA)	1	1
RJ-45 Ethernet cable	1	1
RJ-45 to DB9 rollover cable	1	1
Electrostatic discharge (ESD) wrist strap with cable	1	1
Media kit (flash drives, PCMCIA card adapter)	1	1
Chassis ground lug, 2-hole, 10-32, 6 AWG	1	1
Power cord retainer clips	Premium = 20 Base = 10	-
DC terminal lugs, 2-hole, 10-32, 4 AWG	-	Premium = 40 Base = 20
Antistatic bags	2	

5. Compare the contents of the rack mount kit with [Table 77 on page 209](#).

Table 77: PTX10016 Rack Mount Kit

Component	Quantity
Phillips flat-head screws, 8-32 x .375 in.	12
Rear brackets	2
Right base bracket	1
Left base bracket	1

6. Compare the contents of the front panel kit with [Table 78 on page 209](#).

Table 78: PTX10016 Front Panel Kit

Component	Quantity
Front panel	1
Left base bracket	1
Right base bracket	1
Latch brackets	2
Phillips flat-head screws	8
Documentation Roadmap Card	1

SEE ALSO

| [PTX10016 Components and Configurations](#) | 15

Register Products—Mandatory to Validate SLAs

Register all new Juniper Networks hardware products and changes to an existing installed product using the Juniper Networks website to activate your hardware replacement service-level agreements (SLAs).



CAUTION: Register product serial numbers on the Juniper Networks website and update the installation base data if there is any addition or change to the installation base or if the installation base is moved. Juniper Networks will not be held accountable for not meeting the hardware replacement service-level agreement for products that do not have registered serial numbers or accurate installation base data.

Register your product(s) at <https://tools.juniper.net/svcreg/SRegSerialNum.jsp>.

Update your installation base at <https://www.juniper.net/customers/csc/management/updateinstallbase.jsp>.

Install the Mounting Hardware for a PTX10016

Ensure that you have the following parts and tools available to install the mounting hardware:

- A Phillips (+) screwdriver, number 1, 2, or 3, depending on the size of your rack screws
- A Phillips (+) screwdriver, number 2, to install the screws that connect the rear and base brackets
- Twelve Phillips flat-head screws (provided)
- Fourteen rack screws appropriate for your rack to attach the mounting hardware to the rack (not provided)

You can install a PTX10016 router in a four-post closed frame rack or a four-post open frame rack. Install the mounting hardware on the rack before installing the router.

To mount the chassis on a four-post rack, you must first install the mounting hardware in the rack. The PTX10016 routers comes with a four-piece set of brackets that supports the chassis in the rack. You can order the rack mount kit, EX-MOD-RMK-4POST, as a spare.

NOTE: Two-post installation racks are not supported.

The following are the main pieces of the rack mount kit:

- One left base bracket. The bracket is labeled **LEFT FRONT** on the side of the bracket that faces the interior of the rack, near the holes for attaching the bracket to the rack.
- One right base bracket. The bracket is labeled **RIGHT FRONT** on the side of the bracket that faces the interior of the rack, near the holes for attaching the bracket to the rack.
- Two rear brackets. These brackets are labeled **REAR** on the side of the bracket that faces the interior of the rack, near the holes for attaching the bracket to the rack. The rear brackets are interchangeable; you can use either of the rear brackets with the right or left base bracket.

When you install the base and rear brackets, the adjustable portion of the brackets overlap. Use the overlap area to adjust the total bracket length to fit any of the four standard rack sizes: 19 in. (483 mm), 23.62 in. (600 mm), 30 in. (762 mm), or 31.5 in. (800 mm).

To install the mounting hardware in a four-post rack:

1. Remove the mounting brackets from the rack mount kit box.
2. Decide where to place the chassis in the rack. The best practice is to mount the router in the lowest possible location when the rack is empty. See "[PTX10016 Rack Requirements](#)" on page 152.
3. Line up the left base bracket in the left side of the rack so that its front screw holes line up with the holes in the rack. Use four mounting screws appropriate for your rack to attach the left base bracket to the rack.
4. Line up one of the rear brackets at the left rear of the rack on the same level as the left base bracket, so that the rear bracket overlaps with the left base bracket. The screw holes for connecting the base and rear brackets should overlap. Use four mounting screws appropriate for your rack to attach the rear bracket to the rack.
5. Attach the left base and rear brackets (see [Figure 76 on page 212](#)):
 - a. Insert six of the flat-head screws provided with the mounting brackets into the overlapping bracket holes.

- b. Tighten the screws fully using a number 2 Phillips screwdriver.

Figure 76: Mounting Brackets for Four-Post Rack Installation

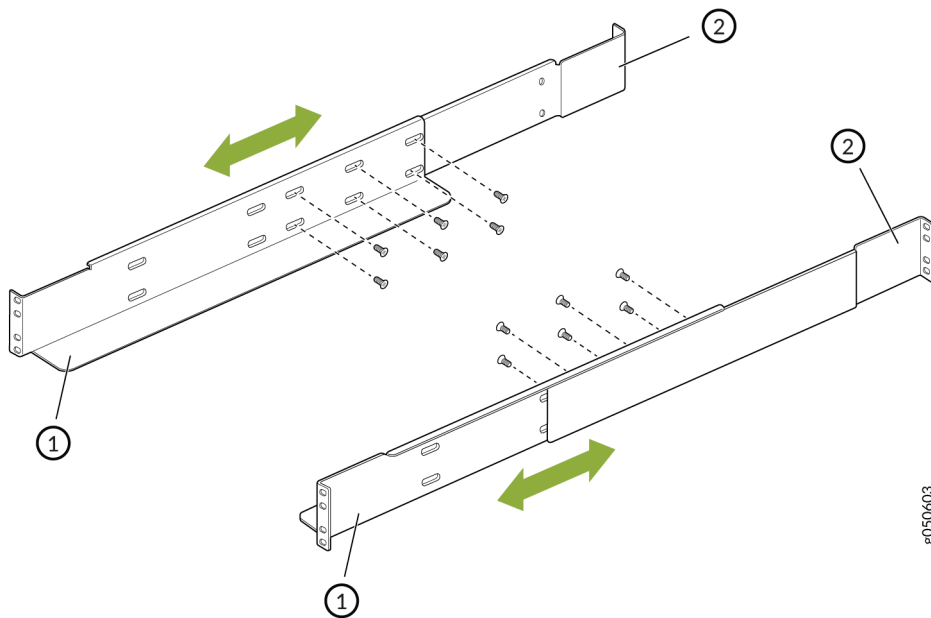

1– Right and left base brackets

2– Rear brackets

6. Repeat the instructions in Step "3" on page 211 through Step "5" on page 211 for installing the right base and rear brackets.

NOTE: Make sure that the left and right brackets are on the same level because if they are not, the chassis will rest at an angle.

RELATED DOCUMENTATION

[General Safety Guidelines and Warnings | 363](#)

[Installation Instructions Warning | 368](#)

Mount a PTX10016 in a Four-Post Rack Using a Mechanical Lift

Before you install the router:

- Prepare the site for installation as described in ["PTX10016 Site Preparation Checklist"](#) on page 147.
- Be sure the site has adequate clearance for both airflow and hardware maintenance as described in ["PTX10016 Clearance Requirements for Airflow and Hardware Maintenance"](#) on page 155.
- Unpack the router as described in ["Unpack the PTX10016 Shipping Pallet"](#) on page 200.
- Install the mounting hardware in the four-post rack, install (see ["PTX10016 Clearance Requirements for Airflow and Hardware Maintenance"](#) on page 155).
- Review chassis lifting guidelines described in ["PTX10016 Chassis Lifting Guidelines"](#) on page 369.

Be sure you have the following parts and tools available to install the router:

- A mechanical lift rated for 1000 lb (453.6 kg)
- Twelve mounting screws appropriate for your rack (not provided)
- A Phillips (+) screwdriver, number 2 or number 3, depending on the size of your mounting screws

Because of the router's size and weight, the PTX10016 can only safely be installed using a mechanical lift.



CAUTION: Do not install line cards in the chassis until after you mount the chassis securely on a rack or cabinet.



CAUTION: Before mounting the router on a rack or cabinet, have a qualified technician verify that the rack is strong enough to support the router's weight and is adequately supported at the installation site.



CAUTION: If you are installing more than one router in a rack or cabinet, plan to install the first router at the bottom of the rack.

To install the router using a mechanical lift (see [Figure 77 on page 214](#)):

1. Be sure the rack or cabinet is placed in its permanent location and is secured to the building. Check that the installation site allows adequate clearance for both airflow and maintenance. For details, see "[PTX10016 Clearance Requirements for Airflow and Hardware Maintenance](#)" on page 155.
2. Load the router onto the lift, making sure it rests securely on the lift platform.

Figure 77: Load the PTX10016 into a Mechanical Lift

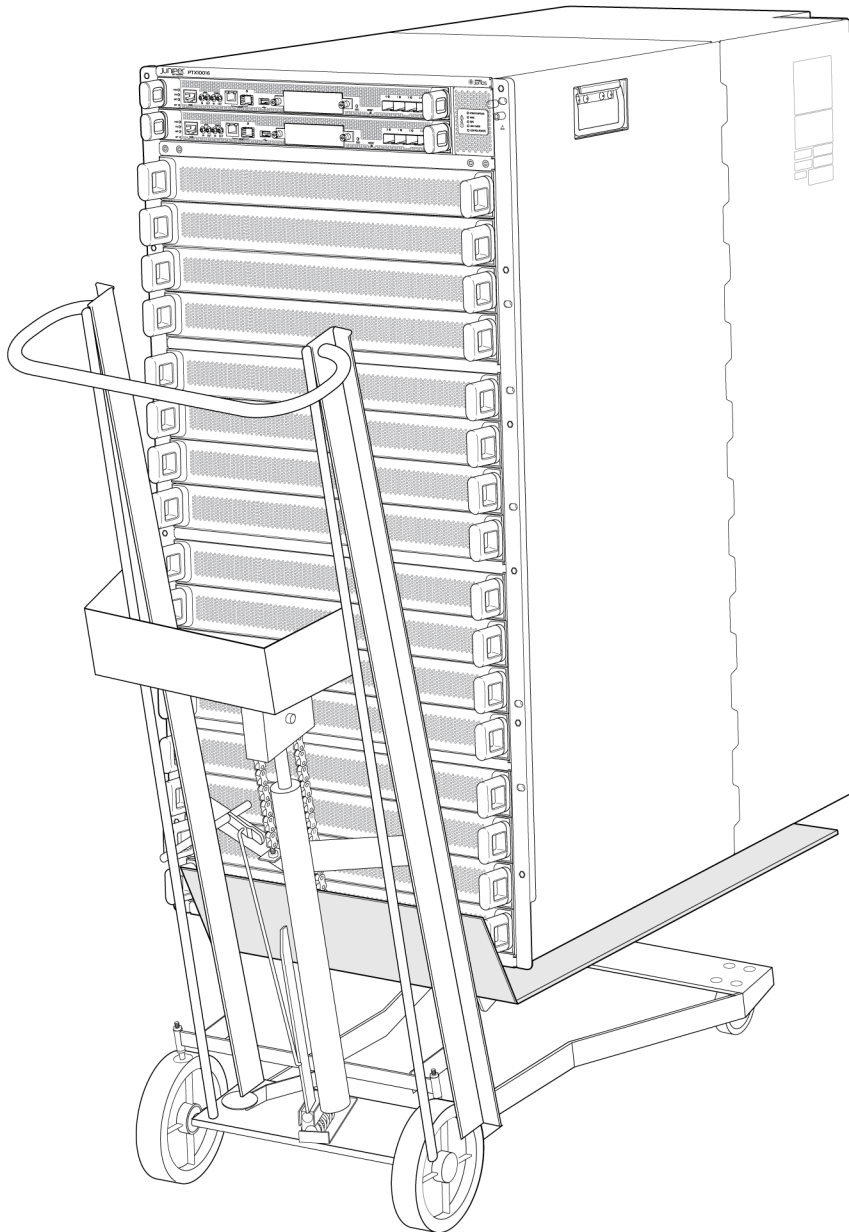

3. Using the lift, align the router in front of the rack, centering it in front of the base brackets.

4. Lift the chassis approximately 0.75 in. (1.9 cm) above the surface of the base brackets. Align the chassis as close as possible to the base brackets.
5. Carefully slide the chassis onto the adjustable base and rear brackets until the chassis flanges contact the rack rails. The base and rear brackets ensure that the holes in the chassis flanges line up with the holes in the rack rails. See [Figure 78 on page 215](#).

Figure 78: Attach the Chassis Flange to the Rack

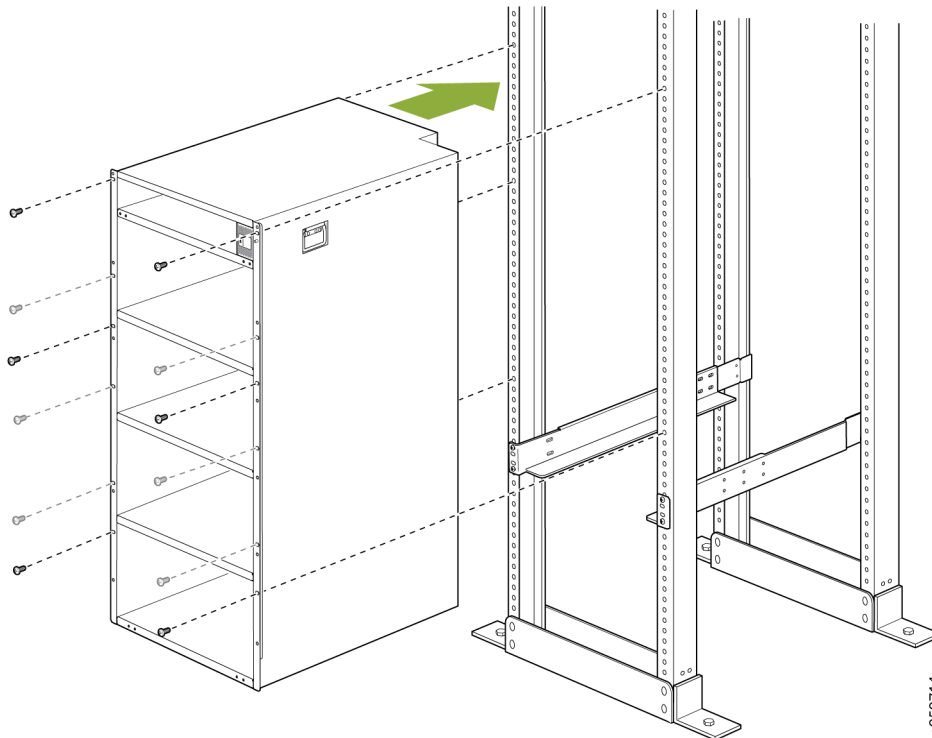

6. Move the lift away from the rack.
7. Attach the chassis to the rack by installing a mounting screw through each open flange hole and rack hole, starting from the bottom.
8. Visually inspect the alignment of the router. If the router is installed properly in the rack, all the mounting screws on one side of the rack are aligned with the mounting screws on the opposite side and the router is level.
9. After ensuring that the router is aligned properly, tighten the screws.
10. After you install the mounting screws and securely bolt the chassis to the rack, reinstall the components in the chassis.

RELATED DOCUMENTATION

[Connect AC Power to the PTX10016 Router | 227](#)

[Connect DC Power to a PTX10016 Router | 228](#)

[Perform the Initial Configuration for the PTX10016 Router | 232](#)

Install the Front Door on a PTX10016 Router

The front door is required on the PTX10016 routers to protect fiber optic cabling and to provide additional protection from electromagnetic interference (EMI). The front door can be installed with or without the optional cable management system.

Be sure you have the following tools and parts before you begin:

- A Phillips (+) screwdriver, number 2
- Front door (provided with the router chassis)
- Right base bracket (provided)
- Left base bracket (provided)
- Two interchangeable latch brackets (provided)
- Eight Phillips flat-head mounting screws (provided)

To install the front door:

1. Wrap and fasten one end of the ESD grounding strap around your bare wrist and connect the other end of the strap to the ESD point on the front of the chassis. See [Figure 79 on page 216](#).

Figure 79: ESD Point for PTX10016 Chassis Front

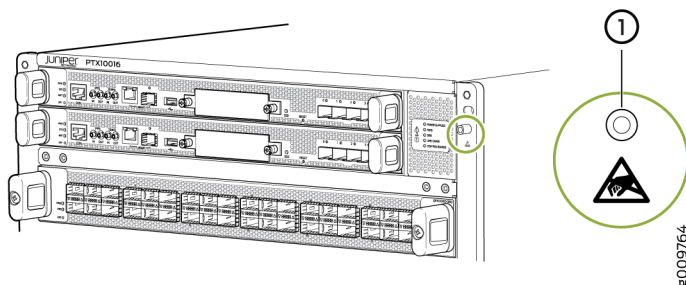

2. Remove the plastic bag that is taped to the front door. This bag holds the brackets and screws.

3. Attach the right and left base brackets to the bottom front of the chassis. Use the Phillips screwdriver to attach the base brackets to the lower front of the chassis using four of the supplied flat-head screws.

NOTE: The base brackets are larger than the latch brackets. The right and left base bracket cannot be interchanged (see [Figure 80 on page 217](#)).

Figure 80: Front Door Mounting Hardware

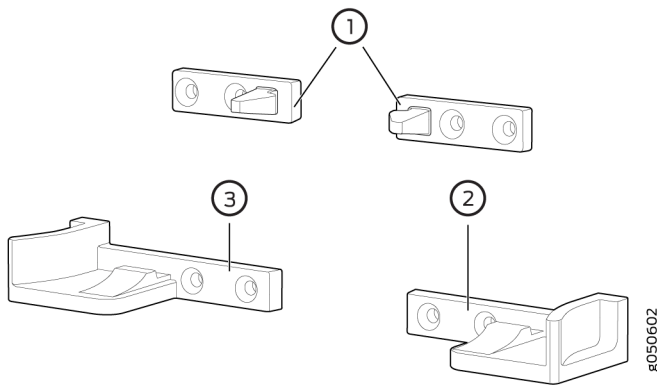

1- Latch brackets

3- Left base bracket

2- Right base bracket

4. Attach the two latch brackets to the chassis. Screw holes are located for each latch bracket between the top line card slot and the Routing and Control Boards (RCBs). Use the Phillips screwdriver to attach two supplied screws for each bracket. See [Figure 81 on page 218](#).

Figure 81: Attach the Front Door Brackets to a PTX10016

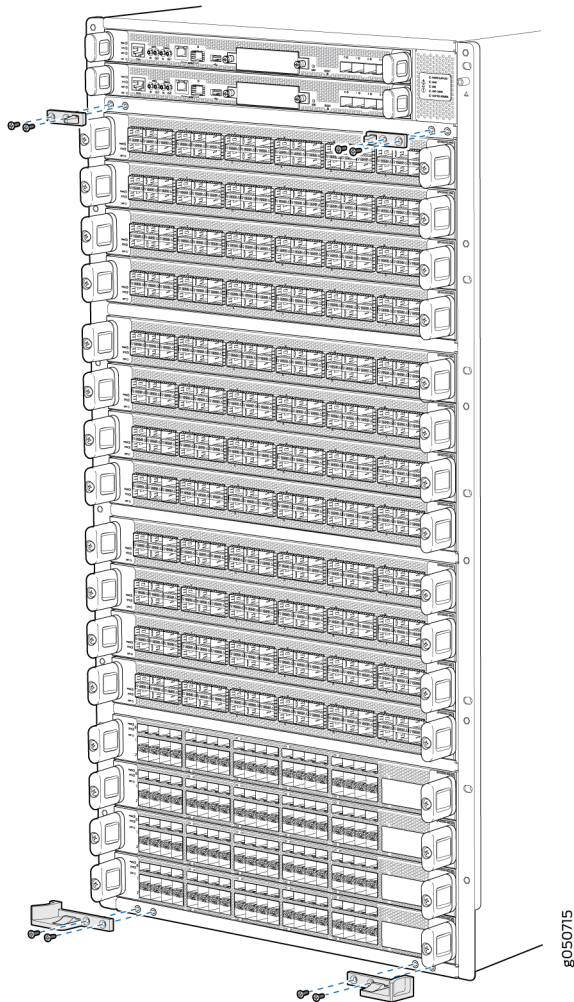

5. Lift the front door and rest it on the two base brackets.
6. Slide the door back on the bracket glides until it engages on the two ramps.

7. Tilt the door towards the chassis until it is vertical with the chassis. The blue release buttons on the side of the door allow the door to latch into place (see [Figure 82 on page 219](#)).

Figure 82: Front Door Installation on a PTX10016

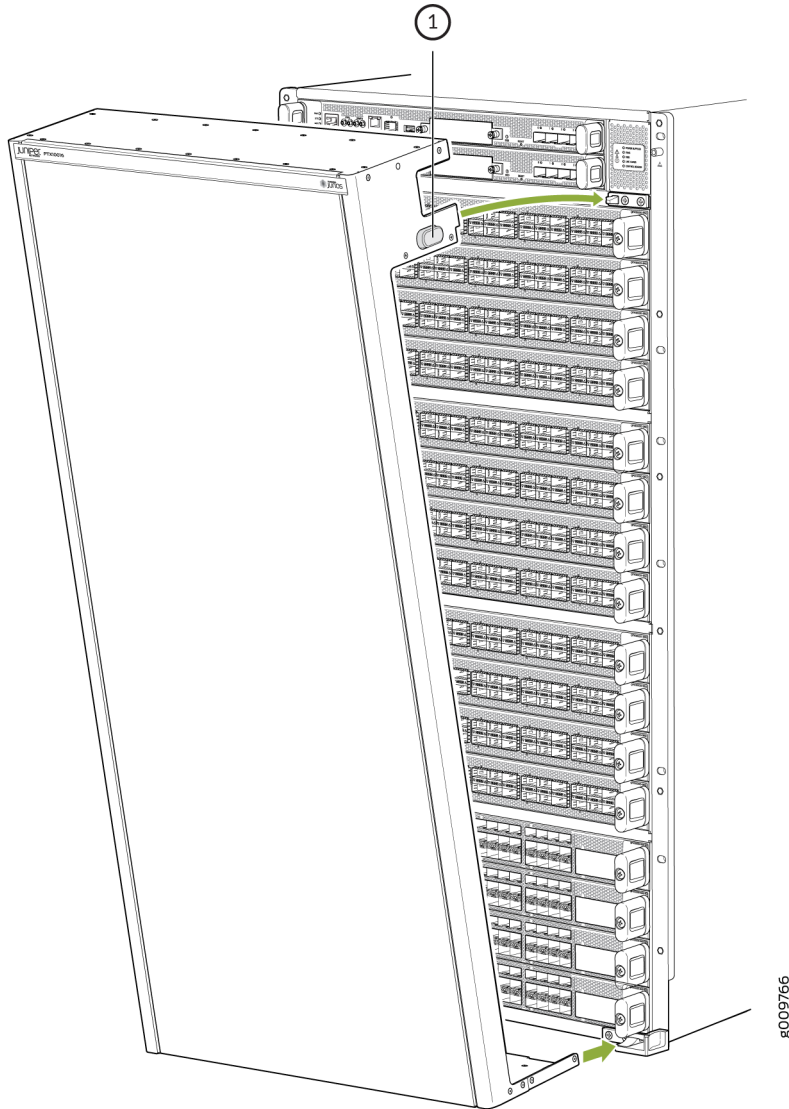

1– Blue release button

The front door has an optional air filter to keep the dust away from the chassis. You should replace the air filter every 6 months.

To install the air filter in the front door:

1. Wrap and fasten one end of the ESD grounding strap around your bare wrist and connect the other end of the strap to the ESD point on the rear of the chassis. See [Figure 79 on page 216](#).

2. Turn the knob of the air filter frame anti-clockwise and move it over the top of the front door. See [Figure 83 on page 220](#).

Figure 83: Air Filter Frame in a PTX10016

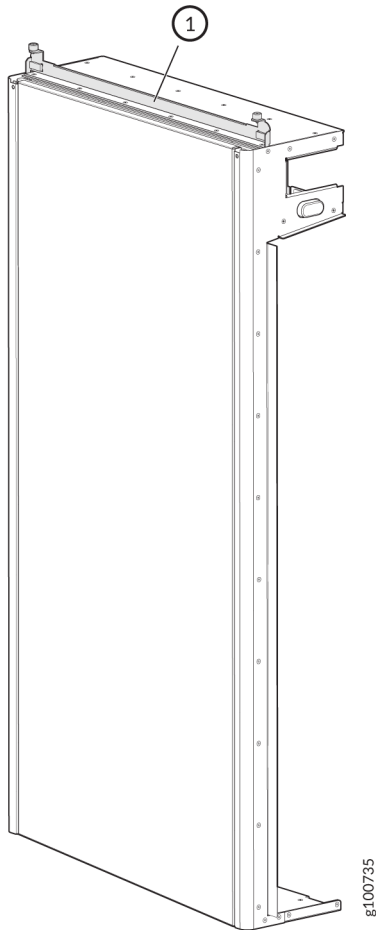

1- Air filter frame



CAUTION: Always keep the air filter in place while the device is operating. Because the fans are very powerful, they could pull small bits of wire or other materials into the through the unfiltered air intake. This could damage the components.



CAUTION: Do not run the router for more than a few minutes without the air filter in place.

3. Hold the air filter with both hands and insert the air filter into the front door until it stops (see [Figure 84 on page 221](#)).

Figure 84: Insert the Air Filter into a PTX10016 Front Door

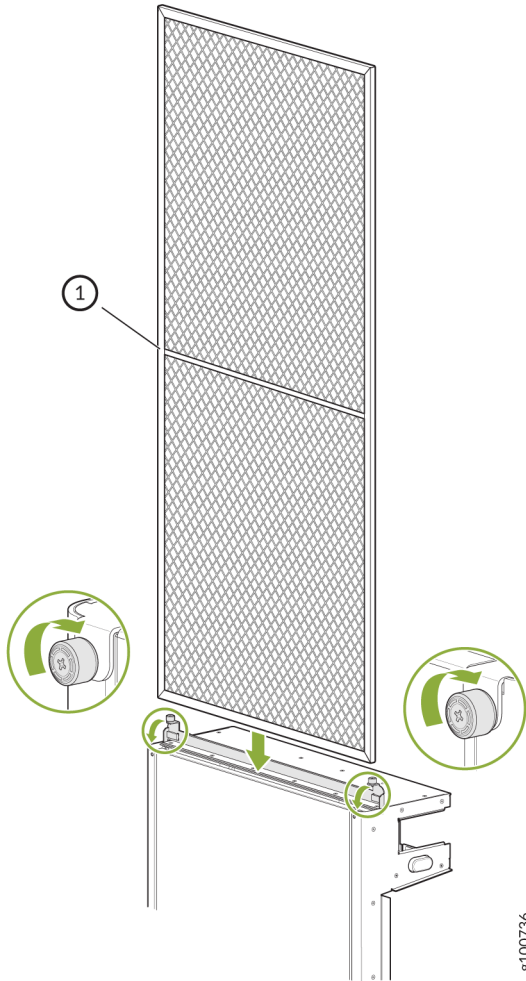

1- Air filter

4. Move the air filter frame over the front door and turn the knob on the air filter frame clockwise back in place.

To remove the air filter in the front door:

1. Wrap and fasten one end of the ESD grounding strap around your bare wrist and connect the other end of the strap to the ESD point on the rear of the chassis. See [Figure 79 on page 216](#).

2. Turn the knob of the air filter frame anti-clockwise and move it over the top of the front door (see [Figure 85 on page 222](#)).

Figure 85: Air Filter Frame in a PTX10016 Front Door

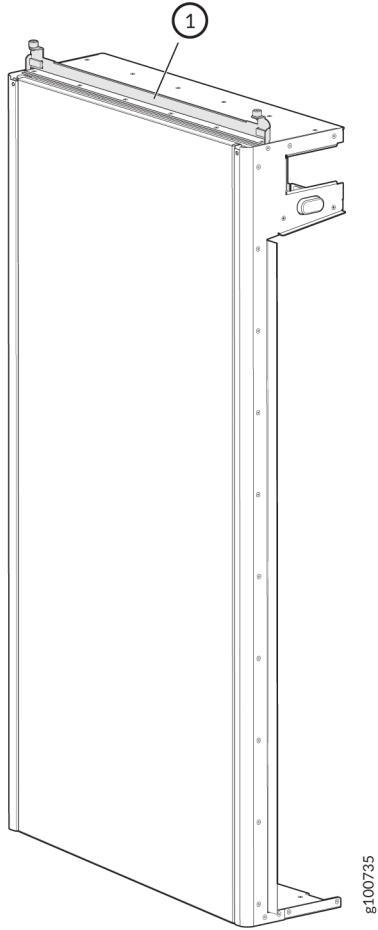

1- Air filter frame

3. Grasp the air filter with both hands and lift it straight up and out of the front door (see [Figure 86](#) on page 223).

Figure 86: Remove the Air Filter from a PTX10016 Front Door

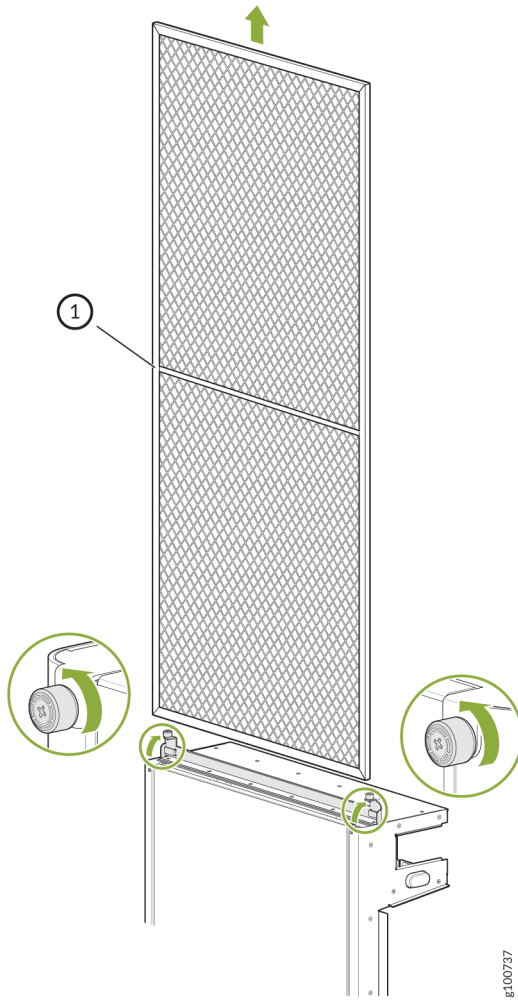

1- Air filter

4. Move the air filter frame over the front door and turn the knob on the air filter frame clockwise back in place.

RELATED DOCUMENTATION

[PTX10016 Optional Equipment](#) | 28

Connect the PTX10016 to Power

IN THIS SECTION

- [Connect a PTX10016 Router to Earth Ground | 224](#)
- [Connect AC Power to the PTX10016 Router | 227](#)
- [Connect DC Power to a PTX10016 Router | 228](#)

PTX10016 routers support AC, DC, high-voltage alternating current (HVAC), and high-voltage direct current (HVDC) power supplies. To connect power to a PTX10016 router, read the following procedures:

NOTE: Do not mix power supply models in the same chassis in a running environment. DC and HVDC can coexist in the same chassis during the hot swap of DC for HVDC.

Connect a PTX10016 Router to Earth Ground

To meet safety and electromagnetic interference (EMI) requirements and to ensure proper operation, you must connect the chassis to earth ground before you connect it to power.

You must install the PTX10016 router in a restricted-access location and ensure that the chassis is always properly grounded. The PTX10016 router has a two-hole protective grounding terminal provided on the chassis. See [Figure 88 on page 227](#). Under all circumstances, use this grounding connection to ground the chassis. For AC-powered systems, you must also use the grounding wire in the AC power cord along with the two-hole grounding lug connection. This tested system meets or exceeds all applicable EMC regulatory requirements with the two-hole protective grounding terminal.

Ensure that a licensed electrician has attached an appropriate grounding lug to the grounding cable you supply. Using a grounding cable with an incorrectly attached lug can damage the switch.

NOTE: Mount your router in the rack before attaching the grounding lug to the router. See ["Mount a PTX10016 in a Four-Post Rack Using a Mechanical Lift" on page 213](#).

Ensure that you have the following parts and tools available:

- An electrostatic discharge (ESD) grounding strap (provided).
- Protective earthing terminal lug (provided).
- Grounding cable for your PTX10016 (not provided)—The grounding cable must be 6 AWG (13.3 mm²), minimum 90° C wire, or as permitted by the local code.
- Grounding lug for your grounding cable (provided)—This bracket attaches to the lower left corner of the router chassis next to the bottom power supply, providing a protective earthing terminal for the router. The grounding lug required is a Panduit LCD6-10A-L or equivalent.
- A Phillips screwdriver (not provided) to tighten the two screws that are mounted on the chassis.

The provided terminal lugs for the JNP10K-PWR-DC2 are Panduit LCD4-14A-L, or equivalent, and sized for 4 AWG (21.1 mm²) power source cables. The 4 AWG (21.1 mm²) stranded wire should be rated 75° C, or per local electrical code. We recommend that you install heat-shrink tubing insulation around the crimped section of the power cables and lugs.

An AC-powered PTX10016 gains additional grounding when you plug the power supply in the router into a grounded AC power outlet by using an AC power cord appropriate for your geographical location. See "[PTX10016 Power Cables Specifications](#)" on page 174.

To connect earth ground to a PTX10016 chassis:

1. Verify that a licensed electrician has attached the cable lug (provided in the accessory kit) to the grounding cable.
2. Connect the other end of the grounding cable to a proper earth ground, such as the rack in which the router is mounted.

3. Wrap and fasten one end of the ESD grounding strap around your bare wrist and connect the other end of the strap to one of the ESD points on the chassis (see [Figure 87 on page 226](#)).

Figure 87: ESD Point for the PTX10016

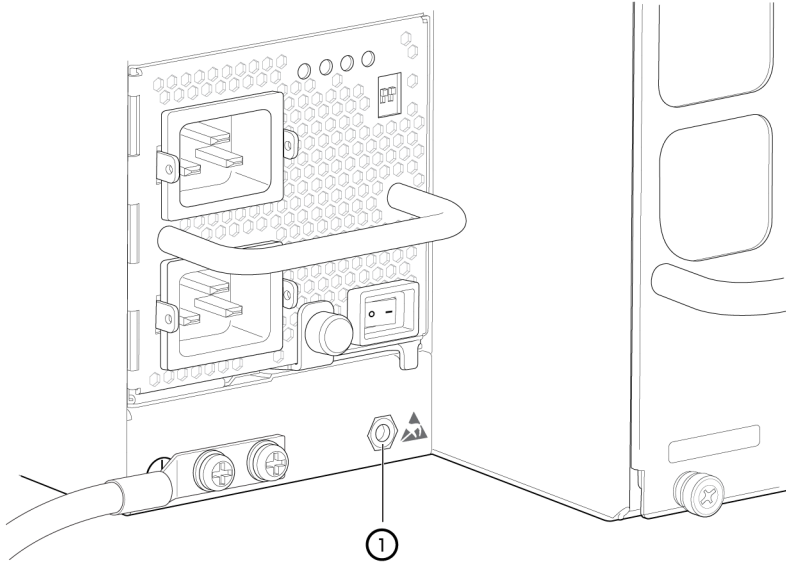

1– ESD point

4. Remove the two screws located next to the ESD point using a Phillips screwdriver.

5. Place the chassis grounding lug and cable over the screw holes with the cable connection pointing to the left. See [Figure 88 on page 227](#).

Figure 88: Connect a Grounding Cable to the PTX10016

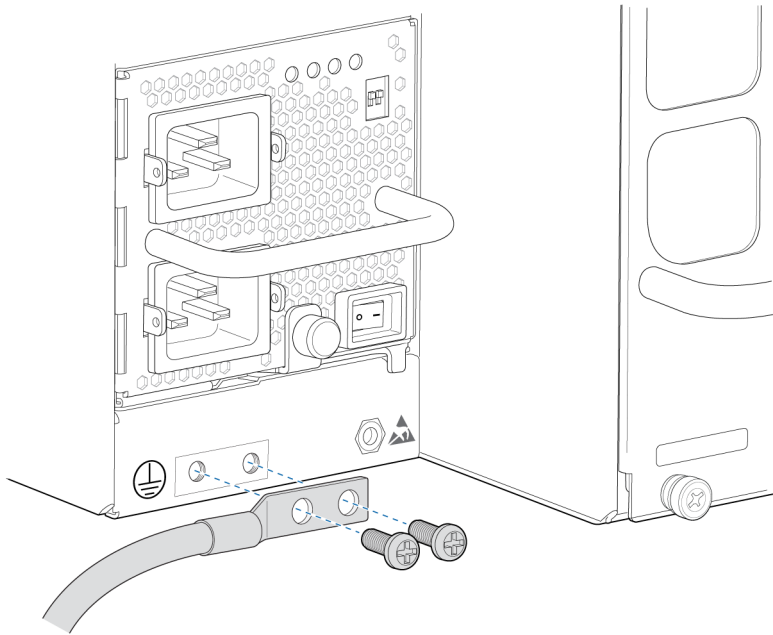

6. Place the two screws over the grounding lug and grounding cable.
7. Tighten the two 10-32 screws using a Phillips screwdriver.
8. Dress the grounding cable and ensure that it does not touch or block access to other device components and that it does not drape where people can trip over it.

Connect AC Power to the PTX10016 Router

Before you begin to connect power to the router, be sure you understand how to prevent ESD damage. See ["Prevention of Electrostatic Discharge Damage" on page 388](#).

After you ground the chassis, add power supplies, and supply power to the chassis, the system initiates the power-on sequence. This sequence can start incrementally with a single power supply, but we do not recommend that you bring up a PTX10016 system with less than three power supplies.

To connect AC power to a PTX10016 chassis:

1. Connect the chassis to earth ground (see ["Connect a PTX10016 Router to Earth Ground" on page 224](#)).



CAUTION: To meet safety and electromagnetic interference (EMI) requirements and to ensure proper operation, a PTX10016 router must be adequately grounded before it is connected to power.

For installations that require a separate grounding conductor to the chassis, use the protective earthing terminal on the rear panel of the PTX10016 to connect to the earth ground.

A PTX10016 router gets additional grounding when you plug the power supply in the router into a grounded AC power outlet by using the AC power cord appropriate for your geographical location. See "[PTX10016 Power Cables Specifications](#)" on page 174.

2. Install power supplies in the router and apply power. See "[Install a JNP10K-PWR-AC Power Supply](#)" on page 258 and "[Install a JNP10K-PWR-AC2](#)" on page 267.

SEE ALSO

[JNP10K-PWR-AC Power Supply](#) | 47

[JNP10K-PWR-AC2 Power Supply](#) | 50

Connect DC Power to a PTX10016 Router

Before you begin to connect power to the router, be sure you understand how to prevent electrostatic discharge (ESD) damage. See "[Prevention of Electrostatic Discharge Damage](#)" on page 388.

The overall process of bringing up a DC-powered chassis involves the proper cabling of the individual power supplies, adding the power supplies to the chassis, and supplying power. The power-on sequence can start incrementally with a single power supply, but it is not recommended that you bring up a PTX10016 system with less than three power supplies.

You must connect each power supply input feed to a dedicated DC power source outlet.

To connect DC power to a PTX10016 chassis:

1. Connect the chassis to earth ground (see "[Connect a PTX10016 Router to Earth Ground](#)" on page 224).



CAUTION: To meet safety and electromagnetic interference (EMI) requirements and to ensure proper operation, a PTX10016 router must be adequately grounded before it is connected to power.

For installations that require a separate grounding conductor to the chassis, use the protective earthing terminal on the rear panel of the PTX10016 to connect to the earth ground.

2. Connect DC power to the JNP10K-PWR-DC or JNP10K-PWR-DC2 power supplies and install in the chassis.

To connect DC power to a JNP10K-PWR-DC power supply, see "[Install a JNP10K-PWR-DC Power Supply](#)" on page 274. To connect DC power to a JNP10K-PWR-DC2 power supply, see "[Install a JNP10K-PWR-DC2 Power Supply](#)" on page 286.

SEE ALSO

[JNP10K-PWR-DC Power Supply | 53](#)

[JNP10K-PWR-DC2 Power Supply | 55](#)

RELATED DOCUMENTATION

[General Safety Guidelines and Warnings | 363](#)

[Grounded Equipment Warning | 375](#)

Connect the PTX10016 to External Devices

IN THIS SECTION

- [Connect a PTX10016 Router to a Network for Out-of-Band Management | 230](#)
- [Connect a PTX10016 Router to a Management Console | 231](#)

You can manage the PTX10016 router by using the two management ports on the Routing and Control board (RCB) for out-band management or through the console port on the RCB. To connect a PTX10016 router to external management devices, read the following sections:

Connect a PTX10016 Router to a Network for Out-of-Band Management

Ensure that you have an appropriate cable available. See ["Management Port Connector Pinouts for the PTX10016 Router" on page 196](#).

You can monitor and manage a PTX10016 router using a dedicated management channel. Each PTX10016 Routing and Control Board (RCB) has two management ports: a 10/100/1000BASE-T RJ-45 port for copper connections and a 1-Gigabit Ethernet SFP port for fiber connections. Use the management ports to connect the RCB to a network for out-of-band management.

NOTE: You cannot use the management ports to perform the initial configuration of the PTX10016. You must configure the management ports before you can successfully connect to the PTX10016 using these ports. See ["Perform the Initial Configuration for the PTX10016 Router" on page 232](#).

To connect a PTX10016 to a network for out-of-band management (see [Figure 89 on page 230](#)):

1. Connect one end of the cable to one of the two management ports (labeled **MGMT**) on one of the RCBs
2. Connect the other end of the cable to the management router.

Figure 89: Connect a PTX10016 to a Network for Out-of-Band Management

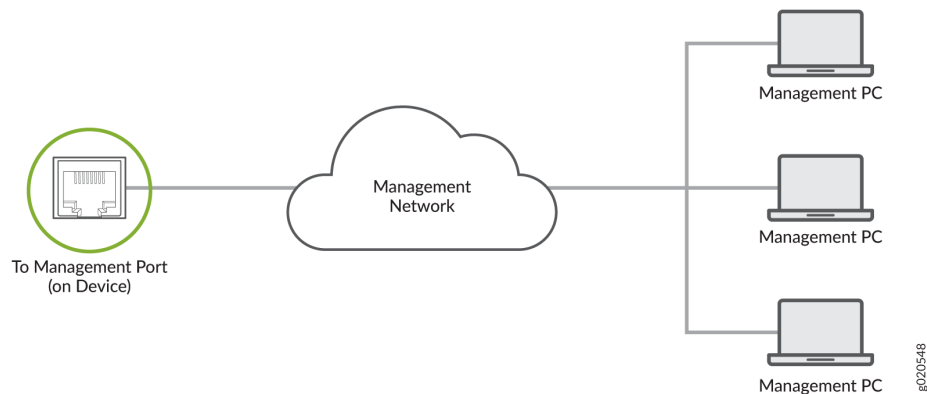

Connect a PTX10016 Router to a Management Console

Ensure that you have an RJ-45 to DB-9 rollover cable available. An RJ-45 cable with an RJ-45 to DB-9 adapter is provided with the device.

NOTE: If your laptop or PC does not have a DB-9 plug connector pin and you want to connect your laptop or PC directly to the PTX10016 RCB, use a combination of the RJ-45 cable and RJ-45 to DB-9 adapter supplied with the device and a USB to DB-9 plug adapter. You must provide the USB to DB-9 plug adapter.

PTX10016 Routing and Control Boards (RCBs) have console ports with RJ-45 connectors. Use the console port to connect the device to a management console or to a console server.

To connect the PTX10016 RCB to a management console (see [Figure 90 on page 231](#) and [Figure 91 on page 231](#)):

1. Connect one end of the Ethernet cable to the console port (labeled **CON**).
2. Connect the other end of the Ethernet cable into the console server (see [Figure 90 on page 231](#)) or management console (see [Figure 91 on page 231](#)).

Figure 90: Connect the PTX10016 Router to a Management Console Through a Console Server

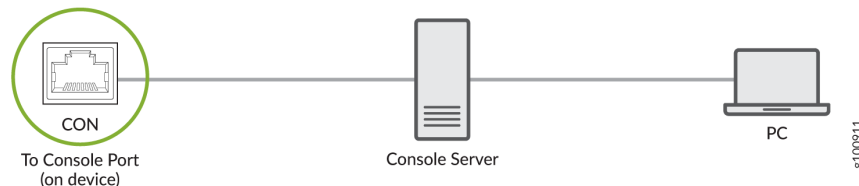
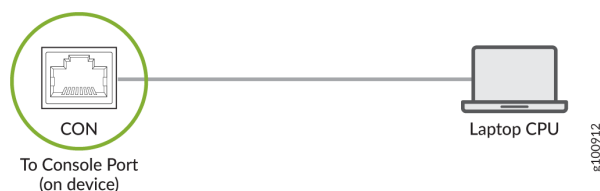

Figure 91: Connect the RCB Console Port Directly to a Management Console



RELATED DOCUMENTATION

[PTX10016 Routing and Control Board Description | 69](#)

[Management Port Connector Pinouts for the PTX10016 Router | 196](#)

[Console Port Connector Pinouts for a PTX10016 | 194](#)

Perform the Initial Configuration for the PTX10016 Router

IN THIS SECTION

- [Before You Start | 232](#)
- [Enter Configuration Mode | 233](#)
- [Establish a Root Password and Optional Host Name | 234](#)
- [Configure the Default Gateway and Ethernet Interface | 234](#)
- [Configure Optional Routes, Services, and Commit the Configuration | 235](#)

You must perform the initial configuration of the PTX10016 through the console port using the CLI or through Zero Touch Provisioning (ZTP). In order to use ZTP to provision the device, you must have access to a Dynamic Host Control Protocol (DHCP) server, and a File Transfer Protocol (anonymous FTP), Hypertext Transfer Protocol (HTTP), or Trivial File Transfer Protocol (TFTP) server on which the software image and configuration files are stored. For more information about using ZTP for provisioning the device, see [Understanding Zero Touch Provisioning](#) in the *Installation and Upgrade Guide*.

These procedures step you through the configuration of the PTX10016 using the console **CON|** **CONSOLE** port on the Routing and Control Board (RCB). For directions on connecting into a console server or a management server, see "[Connect a PTX10016 Router to a Management Console](#)" on page [231](#).

Before You Start

1. Set the following values on the console server or PC:

- Baud Rate—9600
 - Flow Control—None
 - Data—8
 - Parity—None
 - Stop Bits—1
 - DCD State—Disregard
2. Gather the information you will need for configuring the PTX10016:
 - The password you'll set for the root user
 - The name on the system that the PTX10016 will be known as (host name)
 - The IP address and prefix of the default gateway router
 - The IP address and prefix length information for the Ethernet interface
 - The IP address and prefix length of remote prefixes

Enter Configuration Mode

1. Check that the PTX10016 has power.
2. Connect the console port to a laptop or PC using the supplied RJ-45 cable and RJ-45 to DB-9 adapter. The console (**CON**) port is located on the port panel of the router.
3. Log in as **root**. There is no password. If the software booted before you connected to the console port, you might need to press the Enter key for the prompt to appear.

```
Amnesiac <ttyd0>  
login: root
```

4. Start the CLI.

```
root@% cli
```

5. Enter configuration mode.

```
root> configure
```

Establish a Root Password and Optional Host Name

1. Add a password to the root administration user account.

```
[edit]
root@# set system root-authentication plain-text-password
New password: password
Retype new password: password
```

2. (Optional) Configure the name of the router. If the name includes spaces, enclose the name in quotation marks (" ").

```
[edit]
root@# set system host-name host-name
```

Configure the Default Gateway and Ethernet Interface

1. Configure the default gateway.
 - For standard Junos OS systems:

```
[edit]
root@# set routing-options static route default next-hop address
```

- For Junos OS Evolved system:

```
[edit]
root@# set system management-instance
root@# set routing-instances mgmt_junos routing-optins static route prefix/prefix-length
next-hop default-gateway-ip-address
```

2. Configure the IP address and prefix length for the router management interface.

- For standard Junos OS systems:

```
[edit]
root@# set interfaces em0 unit 0 family inet address ip-address/prefix-length
```

- For Junos OS Evolved systems:

```
[edit]
root@# set interfaces re0:mgmt-0 unit 0 family inet address ip-address/prefix-length
```



CAUTION: Although the CLI permits you to configure two management Ethernet interfaces within the same subnet, only one interface is usable and supported.

NOTE: The management ports, `em0` or `re0:mgmt-0` (**MGMT** for RJ-45 connections) and `em1` (also labeled **MGMT** for fiber connections), are found on the front of the RCBs of the PTX10016 router.

Configure Optional Routes, Services, and Commit the Configuration

1. (Optional) Configure the static routes to remote prefixes with access to the management port.

```
[edit]
root@# set routing-options static route remote-prefix next-hop destination-ip retain no-
readvertise
```

2. Enable services such as SSH and Telnet.

NOTE: You will not be able to log in to the router as the root user through Telnet. Root login is allowed only through SSH.

```
[edit]
root@# set system services telnet
```

3. Commit the configuration to activate it on the router.

```
[edit]
root@# commit
```

RELATED DOCUMENTATION

[PTX10016 Packet Transport Router Description | 2](#)

[PTX10016 Installation Overview | 199](#)

4

CHAPTER

Maintaining Components

Install and Remove PTX10016 Routing and Control Boards | 238

Install and Remove PTX10016 Cooling System Components | 242

Install and Remove PTX10016 Power System Components | 257

Install and Remove PTX10016 Switch Fabric Components | 300

Install and Remove PTX10016 Line Card Components | 311

PTX10016 Transceiver and Fiber-Optic Cable Installation and Removal | 323

Remove the PTX10016 Router from the Rack | 330

Install and Remove PTX10016 Routing and Control Boards

IN THIS SECTION

- [Install a PTX10016 Routing and Control Board | 238](#)
- [Remove a PTX10016 Routing and Control Board | 241](#)

We ship PTX10016 routers with one or two Routing and Control Boards (RCBs) preinstalled in the chassis, depending on the configuration. You can install RCBs in the two top slots on the front of the chassis.

When you power on a router with a single RCB preinstalled in it, the RCB comes online as the primary and powers on the line cards and the switch fabric. If you install the second RCB, it powers up and the Routine Engine comes online in the backup mode; you must bring the control board of that RCB online by using the [request chassis cb online](#) command.

When you power on a router with two RCBs installed in it for the first time, the RCB installed in slot 0 comes online as the primary and powers on the line cards and the switch fabric, and the RCB installed in slot 1 comes online as the backup by default. You can change this configuration by using the CLI. If you replace an RCB, it powers up and the Routine Engine comes online in the backup mode; you must bring the control board of that RCB online by using the [request chassis cb online](#) command.

To install or remove an RCB, read the following sections.

Install a PTX10016 Routing and Control Board

In redundant configurations, a PTX10016 RCB is a hot-removable and hot-insertable field-replaceable unit (FRU). In base configurations, you need to install a second RCB before removing a failing RCB in order to prevent the router from shutting down.

Before you install an RCB, ensure that you have an electrostatic discharge (ESD) grounding strap.

To install an RCB:

1. Wrap and fasten one end of the ESD grounding strap around your bare wrist and connect the other end of the strap to one of the ESD points on the chassis (see [Figure 92 on page 239](#)).

Figure 92: ESD Point on the Front of the PTX10016 Chassis

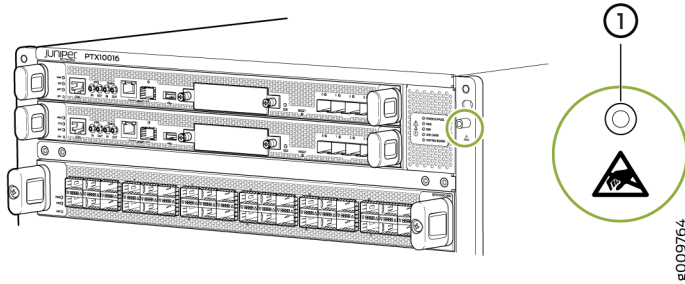

1– ESD point

2. Either remove the cover from the available RCB slot (see [Figure 93 on page 239](#)) or remove the failing RCB (see ["Remove a PTX10016 Routing and Control Board" on page 241](#)).

Figure 93: Remove an RCB Cover

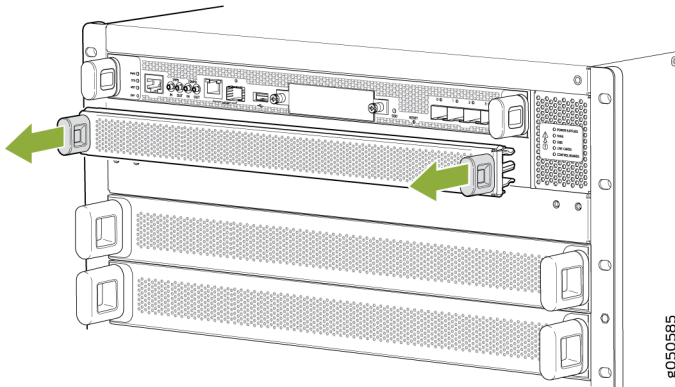

3. Remove the new RCB from the antistatic bag and inspect it for any damage before installing it into the chassis.
4. Lift the RCB by its sides, being careful not to bump the connectors.
5. Carefully align the sides of the RCB with the guides inside the chassis.
6. Slide the RCB into the chassis, carefully ensuring that it is correctly aligned.

7. Grasp both handles on the RCB and rotate them simultaneously clockwise until the RCB is fully seated and the handles are vertical (see [Figure 94 on page 240](#)).

Figure 94: Install an RCB

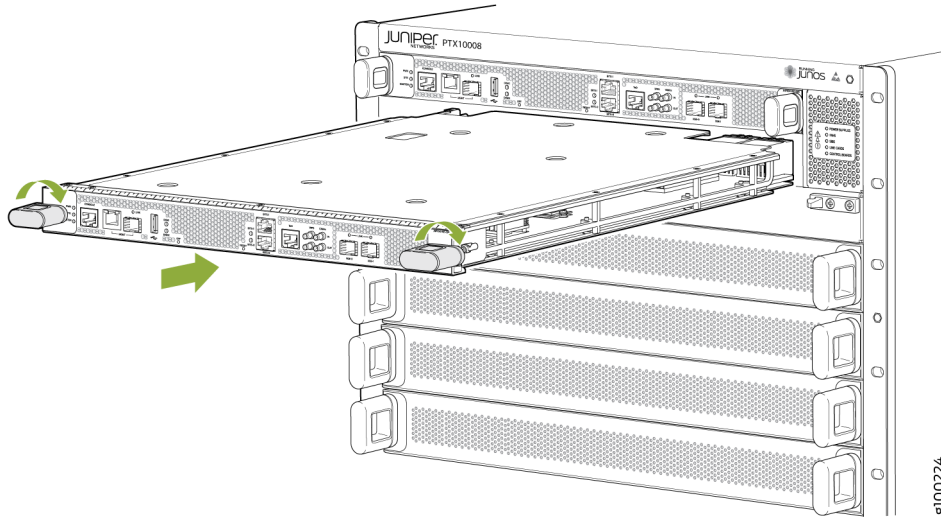

The RCB begins the power-on sequence when fully seated.

8. To verify that the RCB is functioning normally, check the **PWR** LED on its faceplate and the **CONTROL BOARDS** LED on the status panel. Both LEDs should light steadily shortly after the RCB is installed. If the **PWR** LED is blinking yellow, there might be insufficient power available. See ["PTX10016 Power Planning" on page 160](#) and ["Power Requirements for PTX10016 Components" on page 161](#) to ensure that you have adequate power for the additional unit.

Another method of verifying that the RCB is online is to use the following CLI command:

```
user@host> show chassis environment cb
```

SEE ALSO

[Power Requirements for PTX10016 Components | 161](#)

[PTX10016 Routing and Control Board LEDs | 72](#)

Remove a PTX10016 Routing and Control Board

In redundant configurations, a PTX10016 RCB is a hot-removable and hot-insertable field-replaceable unit (FRU). In base configurations, you need to install a second RCB before removing a failing RCB in order to prevent the router from shutting down. We recommend that you take base systems offline before replacing the RCB.

Before you remove a RCB, ensure that you have an electrostatic discharge (ESD) grounding strap.



CAUTION: In base configurations, removal of the RCB causes the system to shut down. In redundant configurations, removal of the RCB causes the system to reboot and start the election process for a new primary.

To remove a RCB:

1. Take the RCB offline.

Place an electrostatic bag or antistatic mat on a flat, stable surface.

2. Wrap and fasten one end of the ESD grounding strap around your bare wrist and connect the other end of the strap to one of the ESD points on the chassis (see [Figure 95 on page 241](#)).

Figure 95: ESD Point on the Front of the PTX10016 Chassis

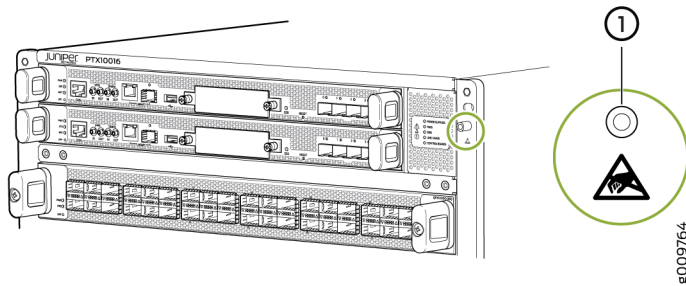

1– ESD point

3. Simultaneously rotate the RCB handles counterclockwise to unseat the RCB.

4. Grasp the handles and slide the RCB about halfway out of the chassis (see [Figure 96 on page 242](#)).

Figure 96: Remove an RCB

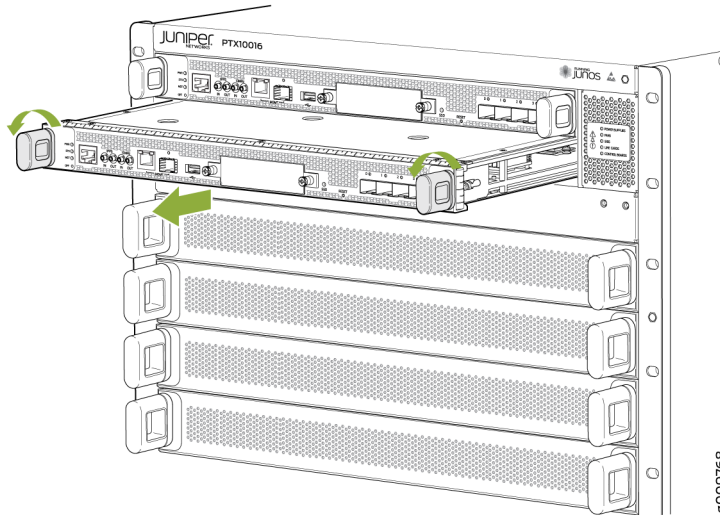

5. Grasp each side of the RCB and slide it completely out of the chassis.
6. Place the RCB on the antistatic mat.
7. If you are not replacing the RCB immediately, install a cover in the empty slot.

SEE ALSO

[How to Handle and Store PTX10016 Line Cards, RCBs, and SIBs | 300](#)

Install and Remove PTX10016 Cooling System Components

IN THIS SECTION

- [Install a PTX10016 Fan Tray | 243](#)
- [Remove a PTX10016 Fan Tray | 246](#)
- [Install a PTX10016 Fan Tray Controller | 251](#)

- [Remove a PTX10016 Fan Tray Controller | 254](#)

The PTX10016 router has two independent, field-replaceable fan trays. To install or remove the fan trays and fan tray controller, read the following sections.

Install a PTX10016 Fan Tray

Before you begin to install a fan tray:

- Ensure you understand how to prevent ESD damage. See "[Prevention of Electrostatic Discharge Damage](#)" on page 388.
- Ensure that you have the following parts and tools available to install a fan tray in a PTX10016 router:
 - Electrostatic discharge (ESD) grounding strap
 - A Phillips (+) screwdriver, number 1 or 2 (optional), for the captive screws
 - A replacement fan tray



CAUTION: The fan tray can be removed and replaced while the router is operating. However, the fan tray must be replaced within three minutes of removing the fan tray to prevent the chassis from overheating.

Each fan tray is a hot-removable and hot-insertable field-replaceable unit (FRU); you can remove and replace the fan tray while the router is running without turning off power to the router or disrupting routing functions. There are two models of the fan tray, JNP10016-FAN and the JNP10016-FAN2.

Each fan tray is installed vertically on the rear, or FRU side, of the chassis.

To install any PTX10016 fan tray (JNP10016-FAN, or JNP10016-FAN2):

1. Wrap and fasten one end of the ESD grounding strap around your bare wrist and connect the other end of the strap to one of the ESD points on the chassis (see [Figure 97 on page 244](#)).

Figure 97: ESD Point on the Rear of the PTX10016 Chassis

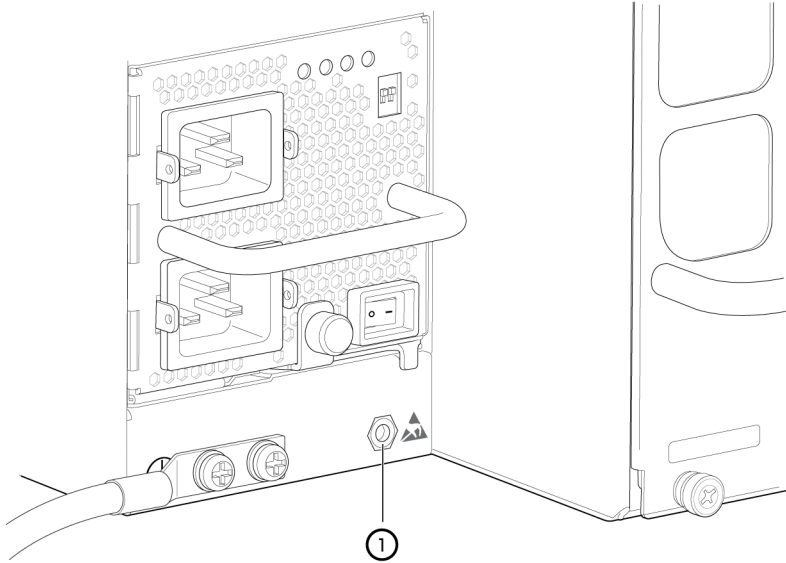

8050729

1– ESD point

2. Grasp the top and bottom fan tray handles and align the bottom of the fan tray with the bottom of the fan tray slot.
3. Rest the bottom edge of the fan tray in the slot and slide the fan tray into place so it is fully seated.

4. Tighten the captive screws until the screws are finger tight. See [Figure 98 on page 245](#) and [Figure 99 on page 246](#).

Figure 98: Installing Fan Tray JNP10016-FAN in a PTX10016

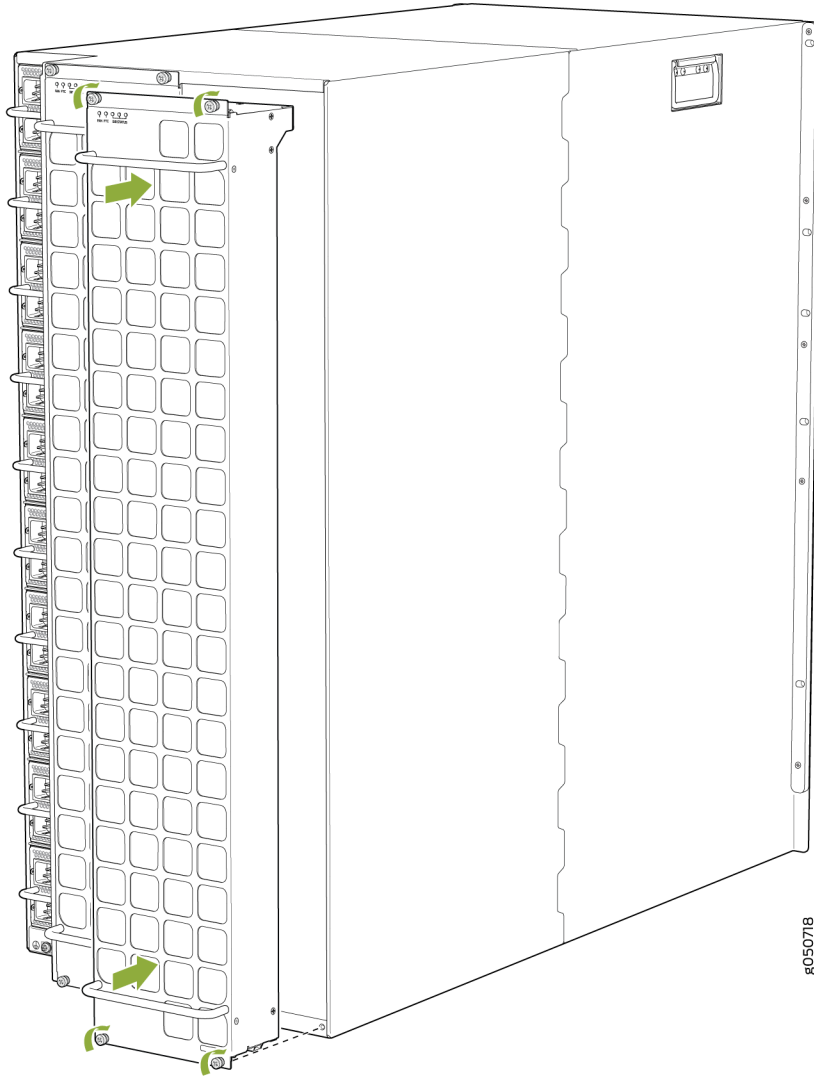
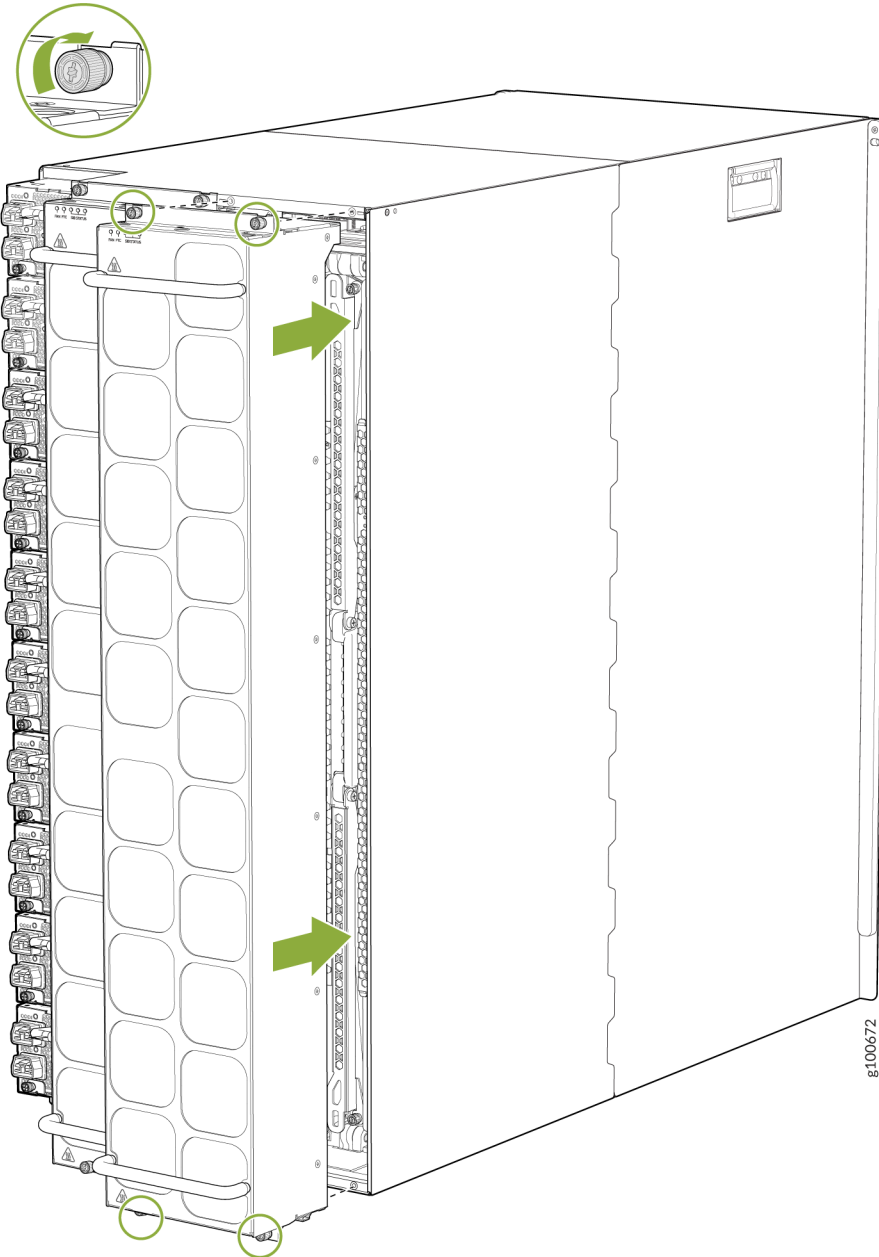

Figure 99: Installing Fan Tray JNP10016-FAN2 in a PTX10016



Remove a PTX10016 Fan Tray

Before you remove a fan tray:

- Ensure you understand how to prevent ESD damage. See "[Prevention of Electrostatic Discharge Damage](#)" on page 388.
- Ensure that you have the following parts and tools available to remove a fan tray from a PTX10016 router:
 - Electrostatic discharge (ESD) grounding strap
 - Replacement fan tray
 - A Phillips (+) screwdriver, number 1 or 2 (optional), for the captive screws

The PTX10016 chassis has two independent, field-replaceable fan trays. Each fan tray is a hot-removable and hot-insertable field-replaceable unit (FRU); you can remove and replace the fan tray while the router is running without turning off power to the router or disrupting routing functions. There are two models of fan tray for the PTX10016 (JNP10016-FAN and JNP10016-FAN2).



CAUTION: Do not remove the fan tray unless you have a replacement fan tray available.

Each fan tray is installed vertically on the rear, or FRU side, of the chassis.



CAUTION: The fan tray can be removed and replaced while the router is operating. However, the fan tray must be replaced within 3 minutes of removing the fan tray to prevent overheating of the chassis.

To remove a PTX10016 fan tray (JNP10016-FAN or JNP10016-FAN2):

1. Wrap and fasten one end of the ESD grounding strap around your bare wrist and connect the other end of the strap to one of the ESD points on the chassis (see [Figure 100 on page 248](#)).

Figure 100: ESD Point on the Rear of the PTX10016 Chassis

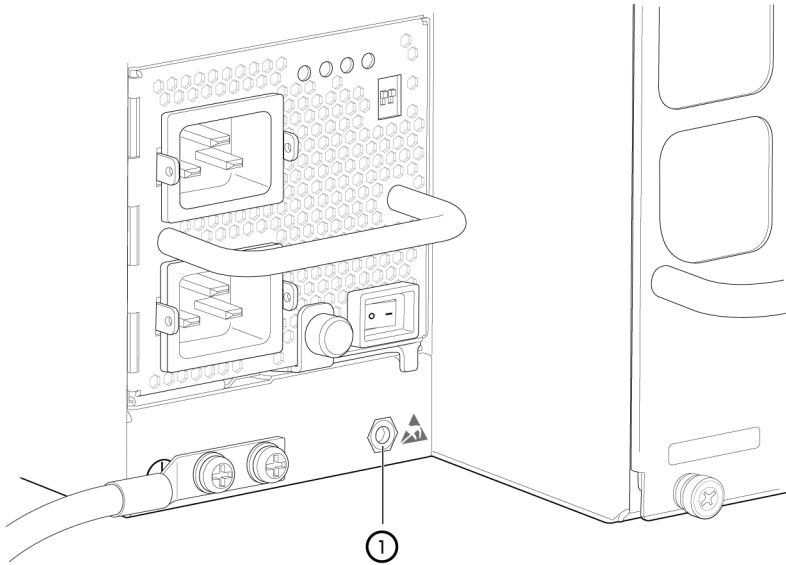

8050729

1– ESD point

2. Loosen the four captive screws either by unscrewing with your thumb and forefinger or with a Phillips screwdriver.

3. Grasp the top and bottom handles and pull the fan tray out about 3 in. (7.6 cm). See [Figure 101](#) on page 249 and [Figure 102](#) on page 250.

Figure 101: Remove Fan Tray JNP10016-FAN

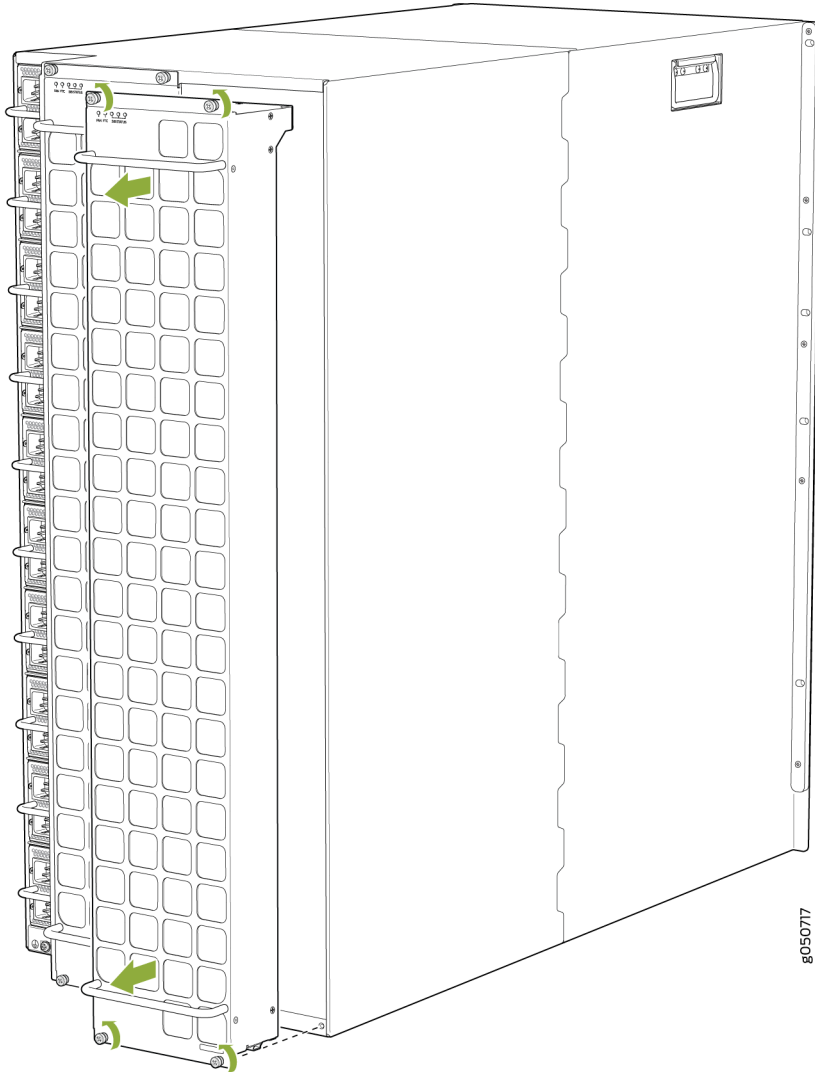
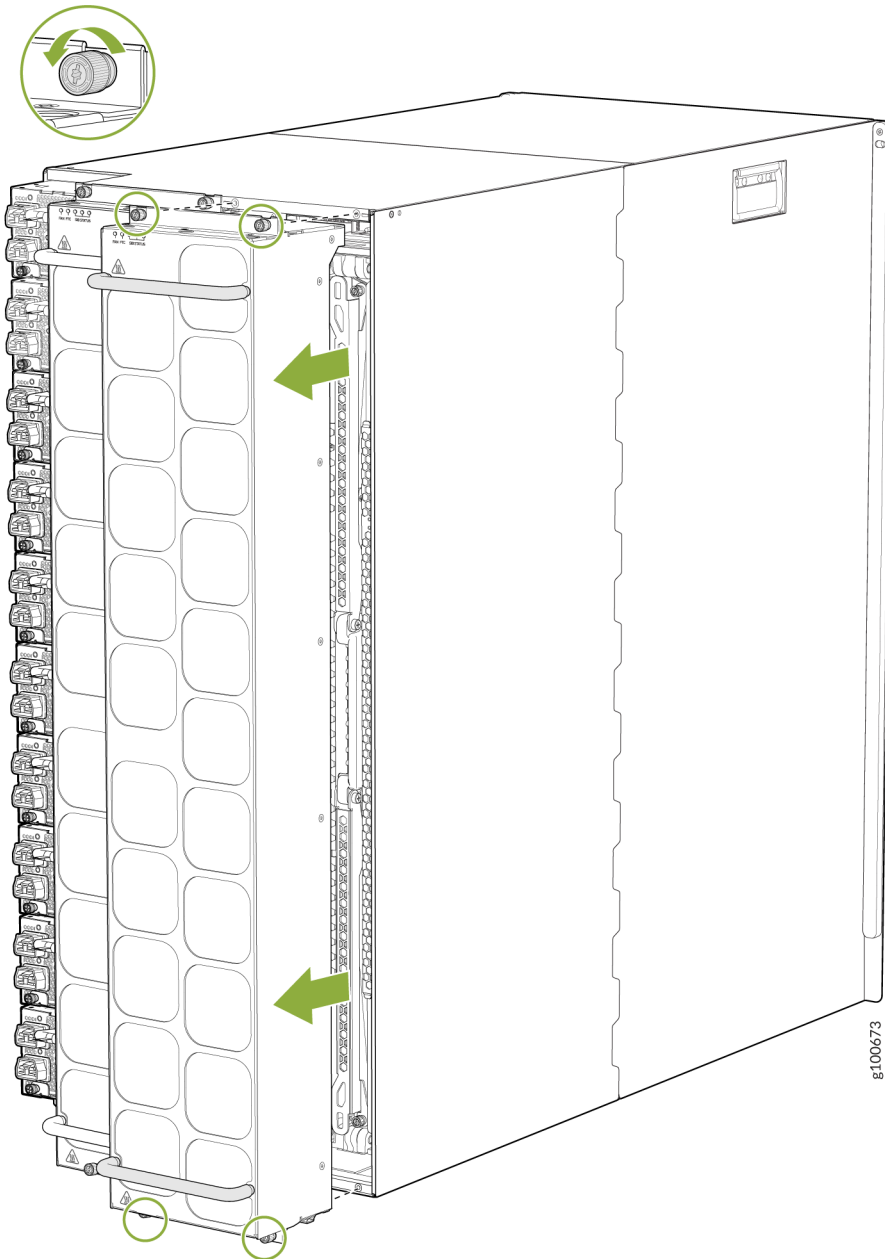

Figure 102: Remove Fan Tray JNP10016-FAN2



4. Tilt the top of the fan tray forward.
5. Using both hands, lift the fan tray out of the slot and rest it on a flat surface with the handles to the side.



CAUTION: Replace a fan tray within three minutes to avoid chassis overheating.

Install a PTX10016 Fan Tray Controller

For each of the two fan trays, there is a fan tray controller. Each controller is a hot-removable and hot-insertable field-replaceable unit (FRU); you can remove and replace one fan tray controller while the router is running without turning off power to the router or disrupting routing functions. There are two models of fan tray controller for the PTX10016 (JNP10016-FAN-CTRL and JNP10016-FTC2). See [Figure 103 on page 251](#) and [Figure 104 on page 251](#).

Figure 103: JNP10016-FAN-CTRL

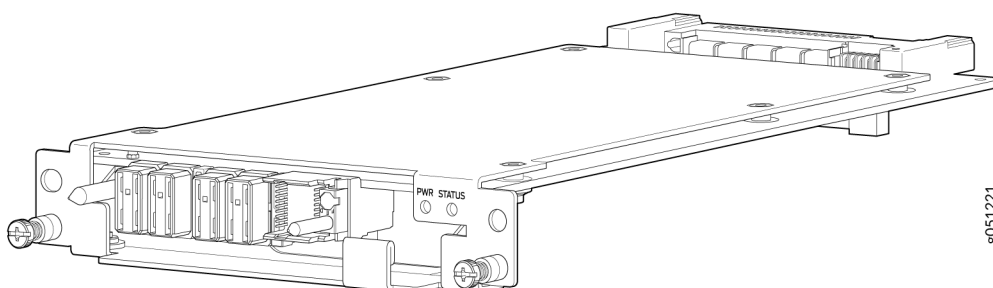
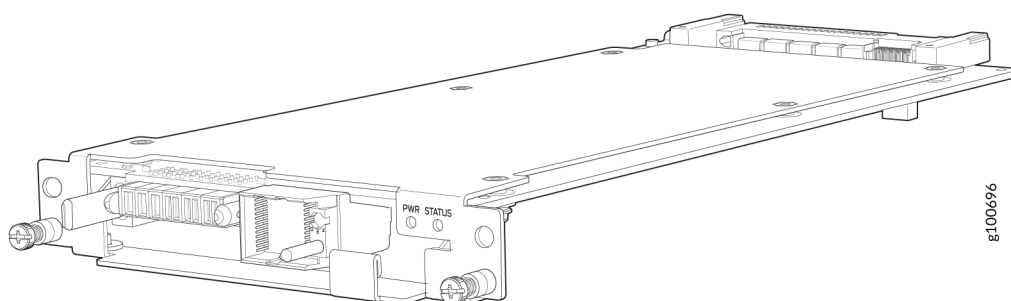

Figure 104: JNP10016-FTC2



CAUTION: Do not remove the fan tray controller unless you have a replacement controller available.

In order to install a fan tray controller, you must first remove the associated fan tray. With the fan tray removed, the fan tray controller is installed horizontally above the Switch Interface Boards (SIBs) at the top of the chassis.

Before you install a fan tray controller:

- You have removed the associated fan tray and fan tray controller. See ["Remove a PTX10016 Fan Tray" on page 246](#) and ["Remove a PTX10016 Fan Tray Controller" on page 254](#).
- Ensure you understand how to prevent ESD damage. See ["Prevention of Electrostatic Discharge Damage" on page 388](#).
- Ensure that you have the following parts and tools available to install a fan tray controller into a PTX10016 router:
 - Electrostatic discharge (ESD) grounding strap
 - Replacement fan tray controller (JNP10016-FAN-CTL or JNP10016-FTC2)
 - A Phillips (+) screwdriver, number 1, for the captive screws

To install a fan tray controller:

1. Wrap and fasten one end of the ESD grounding strap around your bare wrist and connect the other end of the strap to one of the ESD points on the chassis (see [Figure 105 on page 252](#)).

Figure 105: ESD Point on the Rear of the PTX10016 Chassis

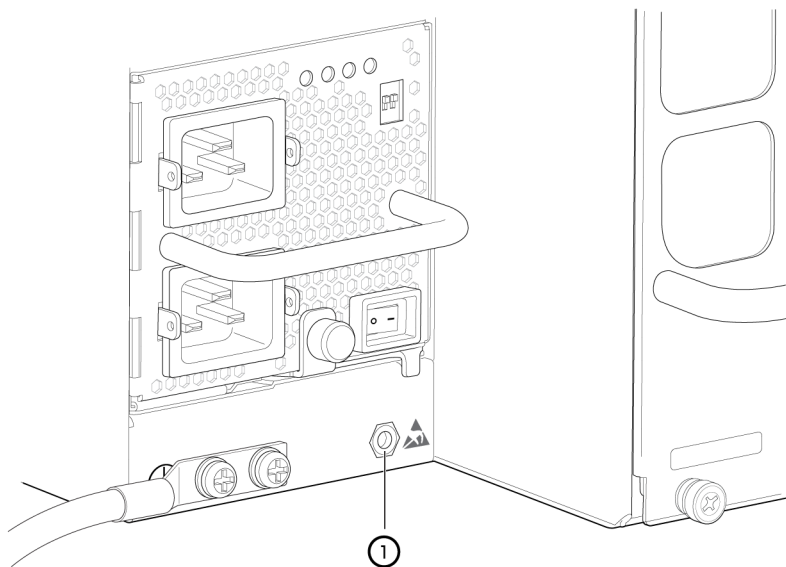

8050729

1– ESD point

2. Remove the replacement fan tray controller from the antistatic bag.

- Carefully slide the fan tray controller into the fan tray controller slot until it is flush with the mounting holes. See [Figure 106 on page 253](#) for JNP10016-FAN-CTRL and [Figure 107 on page 253](#) for JNP10016-FTC2.

Figure 106: Install a JNP10016-FAN-CTRL

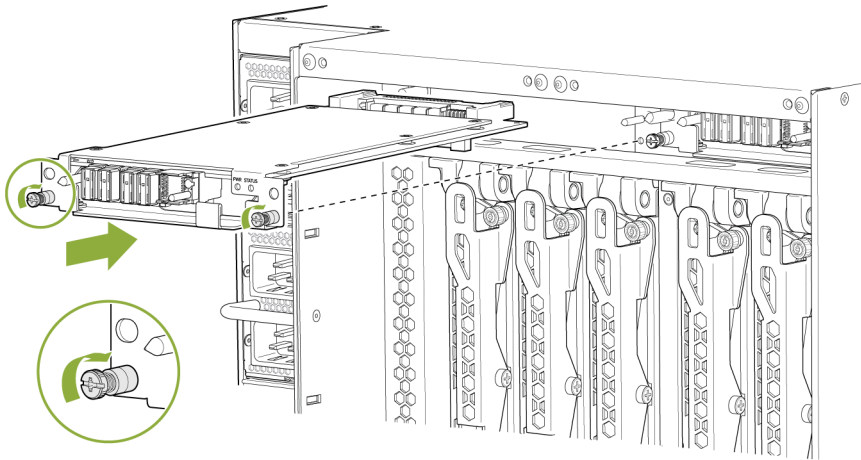
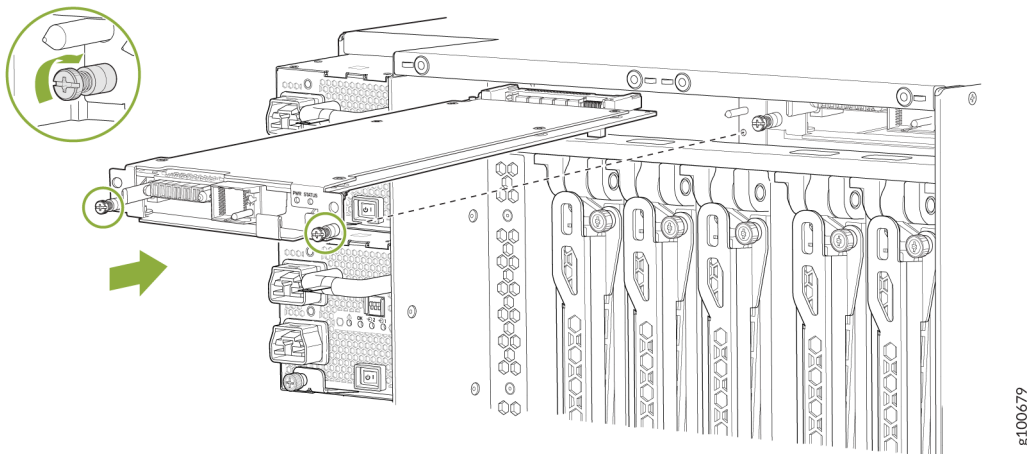

Figure 107: Install a JNP10016-FTC2



- Using a Phillips screwdriver, tighten the captive screws for the fan tray controller.
- Reinstall the fan tray. See ["Install a PTX10016 Fan Tray" on page 243](#).

Remove a PTX10016 Fan Tray Controller

For each of the two fan trays, there is a fan tray controller. Each controller is a hot-removable and hot-insertable field-replaceable unit (FRU); you can remove and replace one fan tray controller while the router is running without turning off power to the router or disrupting routing functions. There are two models of fan tray controller:

- JNP10016-FAN-CTRL, which supports fan tray JNP10016-FAN
- JNP10016-FTC2, which supports fan tray JNP10016-FAN2

See for [Figure 108 on page 254](#) for JNP10016-FAN-CTRL and [Figure 109 on page 254](#) for JNP10016-FTC2.

Figure 108: JNP10016-FAN-CTRL

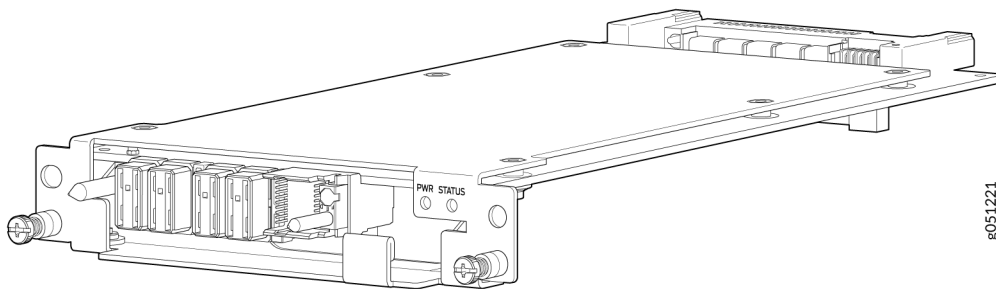

g051221

Figure 109: JNP10016-FTC2

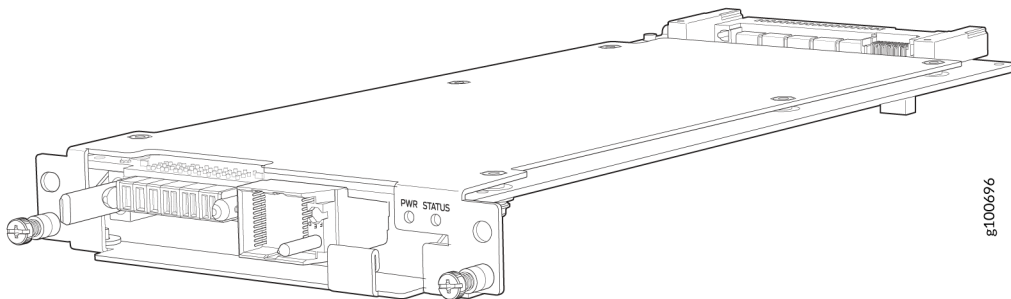

g100696



CAUTION: Do not remove the fan tray controller unless you have a replacement controller available.

In order to access a fan tray controller, you must first remove the fan tray. With the fan tray removed, the fan tray controller is installed horizontally above the switch interface boards (SIBs) at the top of the chassis.

Before you remove a fan tray controller:

- Ensure you understand how to prevent ESD damage. See "[Prevention of Electrostatic Discharge Damage](#)" on page 388.
- Ensure that you have the following parts and tools available to remove a fan tray controller from a PTX10016:
 - Electrostatic discharge (ESD) grounding strap
 - An antistatic bag or an antistatic mat
 - Replacement fan tray controller (JNP10016-FAN-CTRL or JNP10016-FTC2)
 - A Phillips (+) screwdriver, number 1, for the captive screws

All models of fan controller are removed using the same procedure.

1. Remove the fan tray. See "[Remove a PTX10016 Fan Tray](#)" on page 246.
2. Loosen the two captive screws on each side of the fan tray controller.

3. Grasp the fan tray controller and pull it straight out of the slot. See [Figure 110 on page 256](#) for the JNP10016-FAN-CTRL and [Figure 111 on page 256](#) for the JNP10016-FTC2.

Figure 110: Remove a JNP10016-CTRL

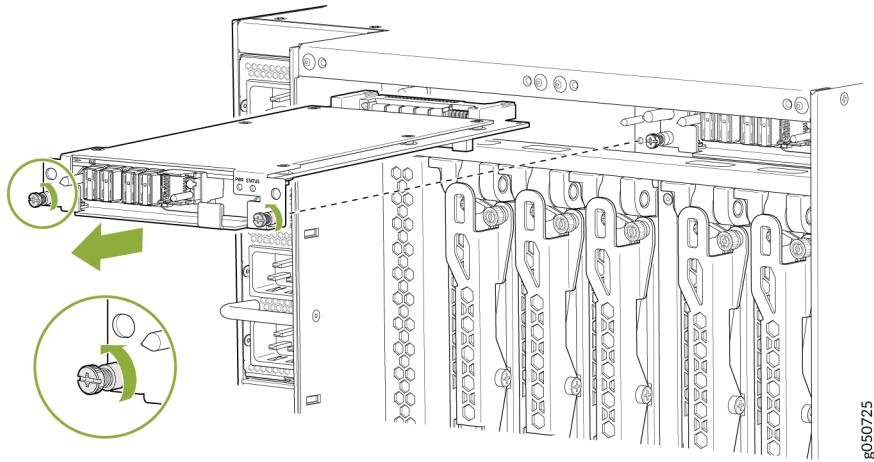
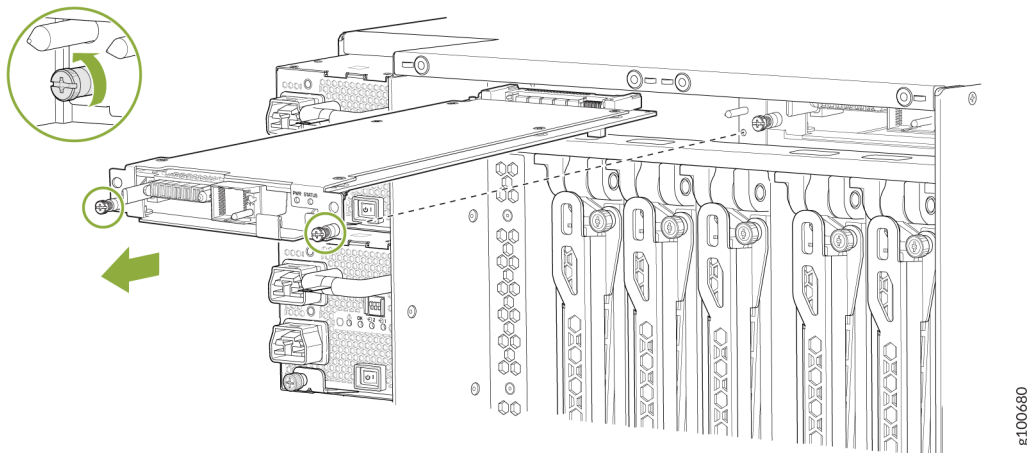

Figure 111: Remove a JNP10016-FTC2



4. Place the fan tray controller in an antistatic bag or on an antistatic mat.

RELATED DOCUMENTATION

[PTX10016 Cooling System and Airflow | 30](#)

[PTX10016 Field-Replaceable Units | 22](#)

Install and Remove PTX10016 Power System Components

IN THIS SECTION

- [Install a JNP10K-PWR-AC Power Supply | 258](#)
- [Remove a JNP10K-PWR-AC Power Supply | 263](#)
- [Install a JNP10K-PWR-AC2 | 267](#)
- [Remove a JNP10K-PWR-AC2 Power Supply | 271](#)
- [Install a JNP10K-PWR-DC Power Supply | 274](#)
- [Remove a JNP10K-PWR-DC Power Supply | 283](#)
- [Install a JNP10K-PWR-DC2 Power Supply | 286](#)
- [Remove a JNP10K-PWR-DC2 Power Supply | 297](#)

PTX10016 routers support AC, DC, high voltage alternating current (HVAC), and high voltage direct current (HVDC) power supplies. To install and remove the power supplies in a PTX10016 router, read the following sections. All power supply models are hot-insertable and hot-removeable field-replaceable units (FRUs). You can install up to 10 power supplies in the rear of the chassis in the slots provided along the left side.



CAUTION: Use the same type of power supply in all slots. Do not mix power supply models in the same chassis.

NOTE: See the heat symbol



. Wear heat-resistant hand gloves while accessing the fan tray and power supply.

Install a JNP10K-PWR-AC Power Supply

Before you install a JNP10K-PWR-AC power supply in the router:

- Ensure you understand how to prevent ESD damage. See "[Prevention of Electrostatic Discharge Damage](#)" on page 388.
- If the AC power source outlets have a power router, set them to the off (O) position.
- Ensure that you have the following parts and tools available to install a JNP10K-PWR-AC power supply:
 - Electrostatic discharge (ESD) grounding strap
 - Phillips (+) screwdriver, number 1
 - Power cords appropriate for your geographical location. See "[PTX10016 Power Cables Specifications](#)" on page 174.
 - Power cord retainer clips

To install a JNP10K-PWR-AC power supply in a PTX10016:

1. Wrap and fasten one end of the ESD grounding strap around your bare wrist and connect the other end of the strap to an ESD point on the chassis. There is an ESD point located next to the

protective earthing terminal and below **PSU_9** on the rear of the PTX10016 (see [Figure 112 on page 259](#)).

Figure 112: ESD Point on the Rear of the PTX10016

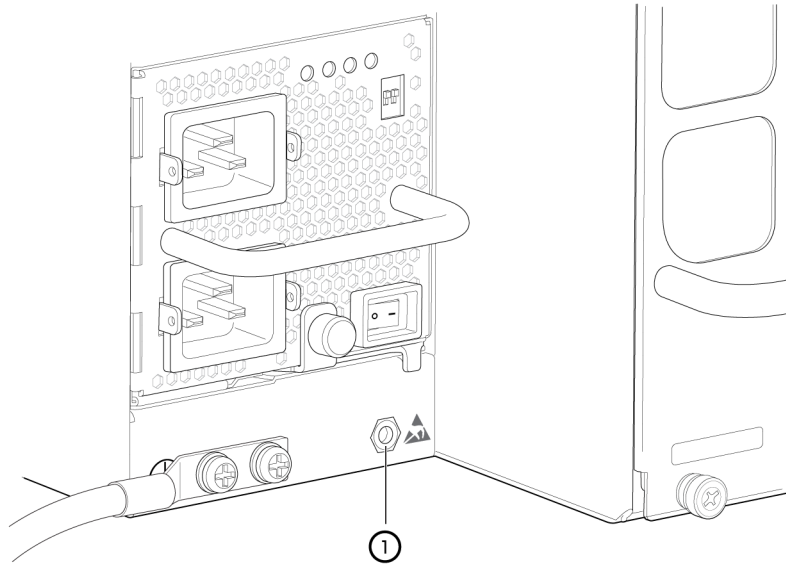

8050729

1– ESD point

2. If the power supply slot has a cover on it, insert your thumb and forefinger into the finger holes, squeeze, and pull the cover out of the slot. Save the cover for later use. See [Figure 113 on page 260](#).

Figure 113: Remove the Power Supply Cover on a PTX10016

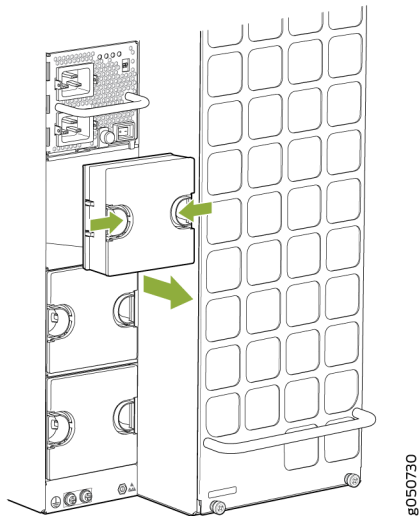

3. Taking care not to touch power supply connections, remove the power supply from its bag.
4. Peel back and remove the protective plastic wrap that covers all four sides of the power supply.
5. Ensure the power switch is set to the standby (O) position. This switch turns off the output voltage; it does not interrupt AC supply.
6. Unscrew the captive screw in the counterclockwise direction by using your fingers or by using the Phillips (+) screwdriver, number 1.
7. Rotate the captive screw away from the faceplate of the power supply to release the latch.

NOTE: You can install the power supplies in any slot labeled **PSU 0** through **PSU 9** (top to bottom) on a PTX10016.

8. Using both hands, place the power supply in the power supply slot on the rear of the system.
9. Slide the power supply straight into the chassis until the power supply is fully seated in the slot. Ensure the power supply faceplate is flush with any adjacent power supply faceplates or power supply covers (see [Figure 114 on page 261](#)).
10. Push the captive screw into the power supply faceplate. Ensure that the screw is seated inside the corresponding hole on the faceplate.

11. Tighten the captive screw by turning it clockwise by using your fingers or by using the Phillips (+) screwdriver, number 1. Do not overtighten—do not apply more than 7.3 lb-in (0.82 Nm) of torque to the screws. When the screw is completely tight, the latch locks into the router chassis.

NOTE: Ensure that the ejector is fully open to avoid scratching the chassis.

Figure 114: Install a JNP10K-PWR-AC Power Supply in a PTX10016

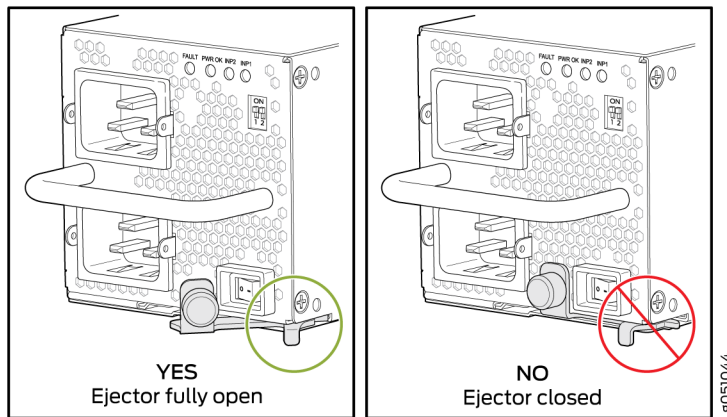
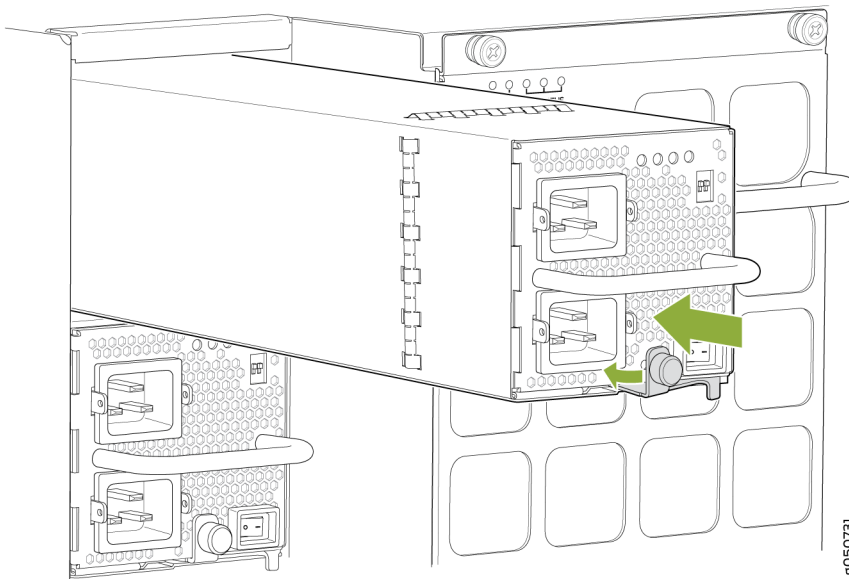

12. Manually load-balance the power supplies as you attach each power cable to a dedicated AC power source outlet. To load-balance, route the power cables to alternate between power sources. The

JNP10K-PWR-AC does not share power; all power comes into INP1 (lower receptacle) and only uses INP2 (top receptacle) only at failover. See [Figure 115 on page 262](#).

Figure 115: Proper Load Balancing for JNP10K-PWR-AC Power Cables on PTX10016



WARNING: Ensure that the power cords do not block access to router components or drape where people can trip on them.

13. Squeeze the two sides of the power cord retainer clip and insert the ends of the clip into the holes in the bracket on each side of the AC appliance inlets on the AC power supply faceplate. See [Figure 116 on page 263](#).
14. Locate two power cords shipped with the router; the cords have plugs appropriate for your geographical location.
15. Insert the power cord coupler into the power supply.

Each AC power supply has two independent 16-A-rated AC inlets on the faceplate. Each inlet must be connected to a dedicated AC power feed to achieve $2n$ source redundancy. If redundancy is not a requirement, use the default input **INP1** for a single connection.

16. Fasten the cord retainer by lowering the clip over the cord and pushing the cord into the adjustment nut of the cord retainer. Rotate the nut until it is tight against the base of the cord. See [Figure 116 on page 263](#).

Figure 116: Power Cord and Retainer Clip

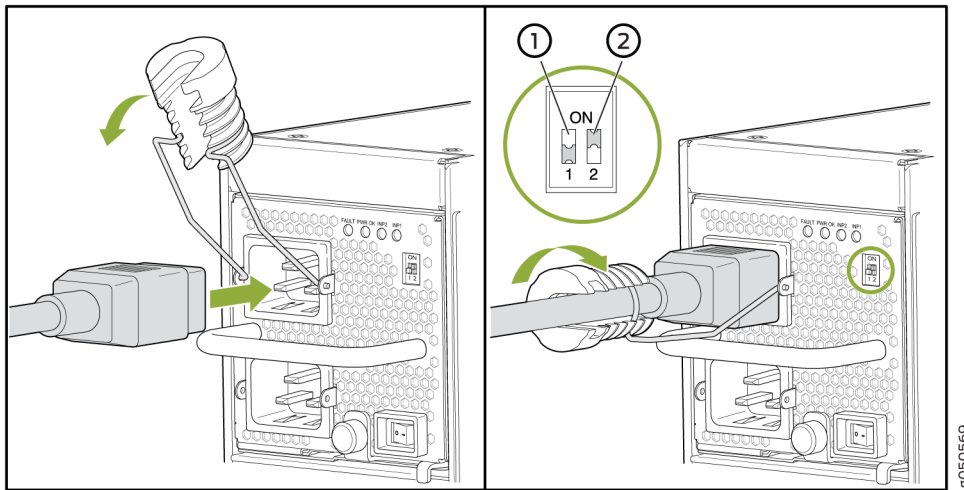

1– Enable switch for **INP1** appears as PS0 in output.

2– Enable switch for **INP2** appears as PS1 in output.



WARNING: Ensure that the power cords do not block access to router components or drape where people can trip on them.

17. If the AC power source outlets have a power switch, set them to the on (I) position.
18. Move the enable switches for input 1 and input 2 to the **ON** position.
19. Verify that the **INP1** and **INP2** LEDs on the power supply faceplate are lit and are on steadily.
20. Press the power switch to the on (I) position.

Remove a JNP10K-PWR-AC Power Supply

Before you remove a JNP10K-PWR-AC power supply from the chassis:

- Ensure you understand how to prevent ESD damage. See "[Prevention of Electrostatic Discharge Damage](#)" on page 388.

- Ensure that you have the following parts and tools available to remove a JNP10K-PWR-AC power supply from a PTX10016 router:
 - Electrostatic discharge (ESD) grounding strap
 - Phillips (+) screwdriver, number 1
 - Replacement power supply or a cover for the power supply slot



CAUTION: Before you remove a power supply, ensure that you have power supplies sufficient to power the router left in the chassis. See "[Power Requirements for PTX10016 Components](#)" on page 161.



CAUTION: Do not leave the power supply slot empty for a long time while the router is operational. Either replace the power supply promptly or install a cover over the empty slot.

To remove a JNP10K-PWR-AC power supply from a PTX10016 router:

1. Wrap and fasten one end of the ESD grounding strap around your bare wrist and connect the other end of the strap to an ESD point on the chassis. There is an ESD point located next to the protective earthing terminal and below **PSU_9** on the PTX10016 (see [Figure 117 on page 264](#)).

Figure 117: ESD Point on the Rear of the PTX10016 Chassis

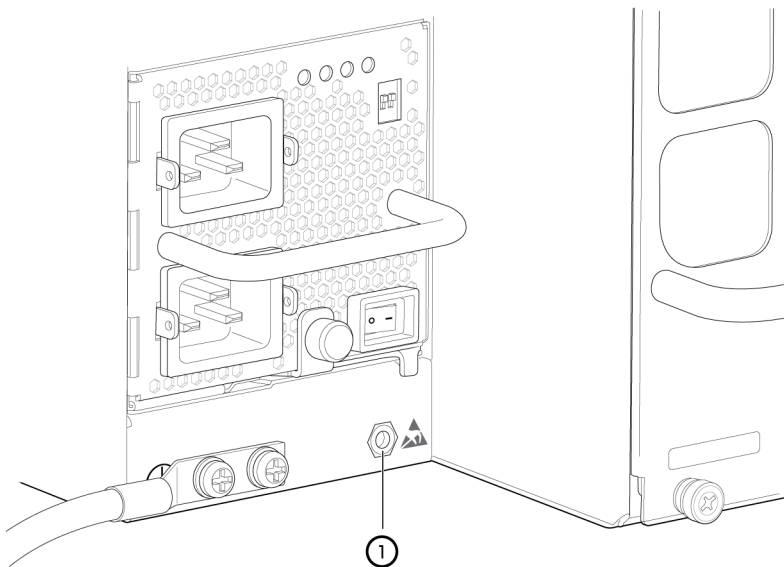

1– ESD point

2. Flip the power switch (○ and |) next to the appliance inlet on the power supply to the standby position (○).
3. Disconnect power from the router by performing one of the following tasks:
 - If the AC power source outlets have a power switch, set them to the off (○) position.
 - If the AC power source outlets do not have a power switch, gently pull the plug end of the power cords connected to the power source outlets out of the outlets.
4. Remove the power cords from the AC appliance inlets on the AC power supply faceplate.
5. Turn the adjustment nut of the power cord retainers counterclockwise till you can see the power cord. Pull the power cord from the slot in the adjustment nuts.
6. Unscrew the captive screw counterclockwise by using your fingers or by using the Phillips (+) screwdriver, number 1. See [Figure 118 on page 265](#).

Figure 118: Remove a JNP10K-PWR-AC Power Supply from a PTX10016

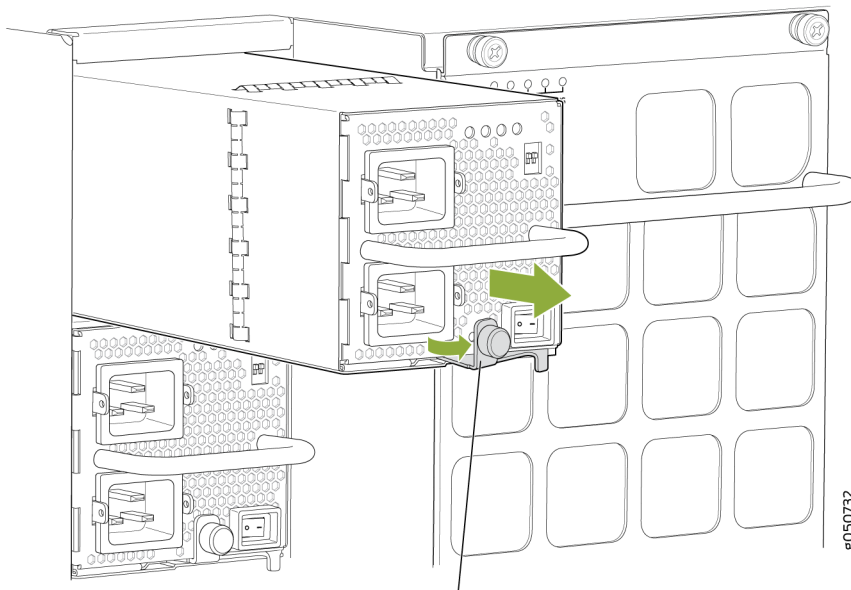

Keep latch in open position during removal.

7. Rotate the captive screw away from the faceplate of the power supply to release the latch.

NOTE: Ensure that the ejector is fully open to avoid scratching the chassis.

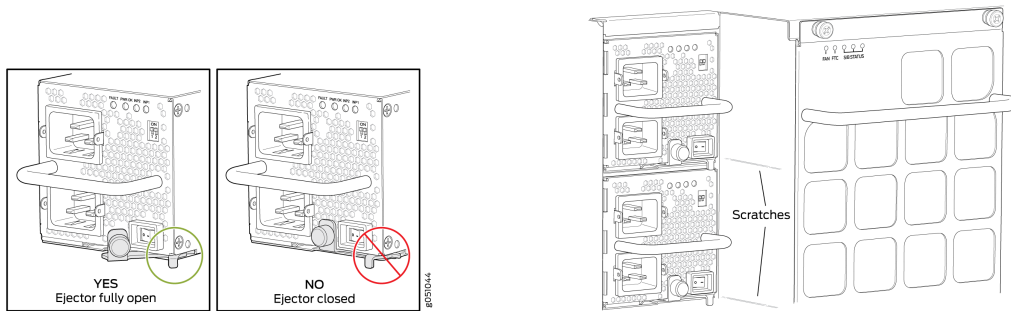

8. Taking care not to touch the power supply output connections, pins, leads, or solder connections, place one hand under the power supply to support it. Grasp the power supply handle with your other hand and pull the power supply completely out of the chassis.



CAUTION: Do not bump the output connections. If the connection hits a solid object, it could damage the power supply.



CAUTION: See the heat symbol



. The power supply surfaces are hot. Allow a few minutes for the power supply to cool by pulling the power supply halfway out of the chassis, or wear protective, heat-resistant gloves while removing the power supply.

9. If you are not replacing the power supply, install the cover over the slot. To install the cover, insert your thumb and forefinger into the finger holes of the cover, squeeze to retract the spring latches, and place the cover in the slot.

Install a JNP10K-PWR-AC2



CAUTION: Use the same type of power supply in all slots. Do not mix power supply models in a production chassis. The only time you are allowed to have two models concurrently running in a system is when you are in the process of swapping out all JNP10K-PWR-AC power supplies with all JNP10K-PWR-AC2 power supplies.



WARNING: Protect yourself from severe burns by wearing heat-protective gloves when removing a running JNP10K-PWR-AC2 power supply from the chassis. The power supply can reach temperatures between 158°F to 176°F (70°C to 80°C) under running conditions.

Before you install a JNP10K-PWR-AC2 power supply in the chassis:

Ensure that you have followed all safety warnings and cautions.

- Ensure you understand how to prevent ESD damage. See "[Prevention of Electrostatic Discharge Damage](#)" on page 388.
- If the AC or DC power source outlets have a power switch, set them to the off (O) position.
- Ensure that you have the following parts and tools available to install an JNP10K-PWR-AC2 power supply:
 - Electrostatic discharge (ESD) grounding strap
 - Phillips (+) screwdriver, number 1
 - Power cables appropriate for your geographical location (for low voltage installations) or input amperage (for high voltage installations). See "[PTX10016 Power Cables Specifications](#)" on page 174. HVAC and HVDC connectors and lugs must be installed by a qualified electrician before installation.

To install a JNP10K-PWR-AC2 power supply in a PTX10016:

1. Wrap and fasten one end of the ESD grounding strap around your bare wrist and connect the other end of the strap to an ESD point on the chassis. There is an ESD point located next to the protective earthing terminal and below **PSU9** on the PTX10016 (see [Figure 119 on page 268](#)).

Figure 119: ESD Point on the Rear of the PTX10016

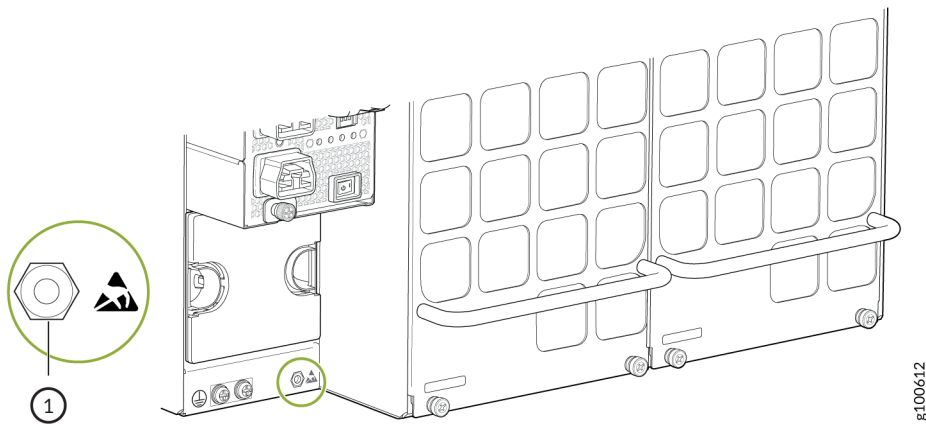

1– ESD point

2. If the power supply slot has a cover in it, insert your thumb and forefinger into the finger holes, squeeze to retract the spring, and pull the cover out of the slot. Save the cover for later use. See [Figure 120 on page 268](#).

Figure 120: Remove the Power Supply Cover on a PTX10016

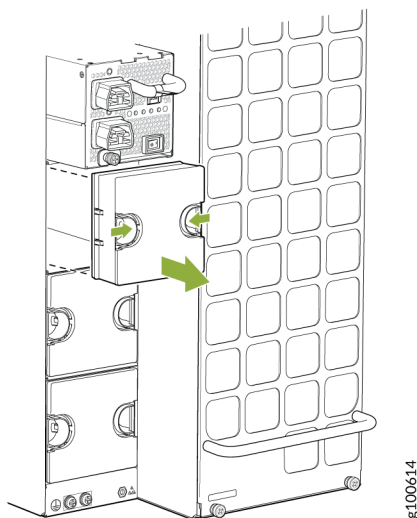

3. Taking care not to touch power supply connections, remove the power supply from its bag.

4. Peel back and remove the protective plastic wrap that covers all four sides of the power supply.
5. Ensure the power switch is set to the standby (O) position. This switch turns off the output voltage; it does not interrupt input power.
6. Unscrew the captive screw in the counterclockwise direction by using your fingers or by using the Phillips (+) screwdriver, number 1.
7. Rotate the captive screw away from the faceplate of the power supply to release the latch.

NOTE: You can install the power supplies in any slot labeled **PSU 0** through **PSU 9** (top to bottom) on a PTX10016.

8. Using both hands, place the power supply in the power supply slot on the rear of the system. Slide the power supply straight into the chassis until the power supply is fully seated in the slot. Ensure the power supply faceplate is flush with any adjacent power supply faceplates or power supply covers (see [Figure 121 on page 269](#)).

Figure 121: Install a JNP10K-PWR-AC2 Power Supply in a PTX10016

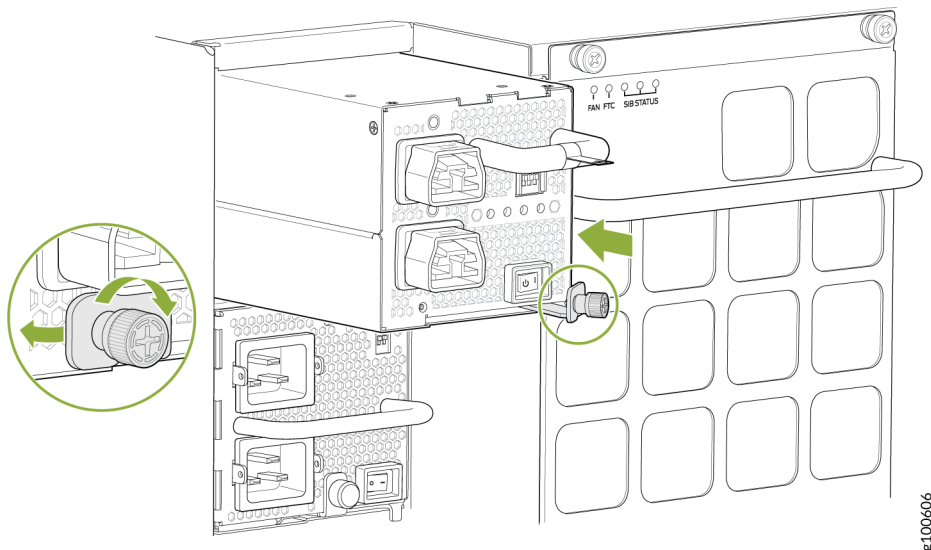

9. Push the captive screw into the power supply faceplate. Ensure that the screw is seated inside the corresponding hole on the faceplate.
10. Tighten the captive screw by turning it clockwise by using your fingers or by using the Phillips (+) screwdriver, number 1. Do not overtighten—do not apply more than 7.3 lb-in (0.82 Nm) of torque to the screws. When the screw is completely tight, the latch locks into the router chassis.

- Attach each power cable to a dedicated power source(A and B). The JNP10K-PWR-AC2 only requires that each power supply be connected to a separate source.

Figure 122: Proper Load Balancing for JNP10K-PWR-AC2 Power Cables on PTX10016

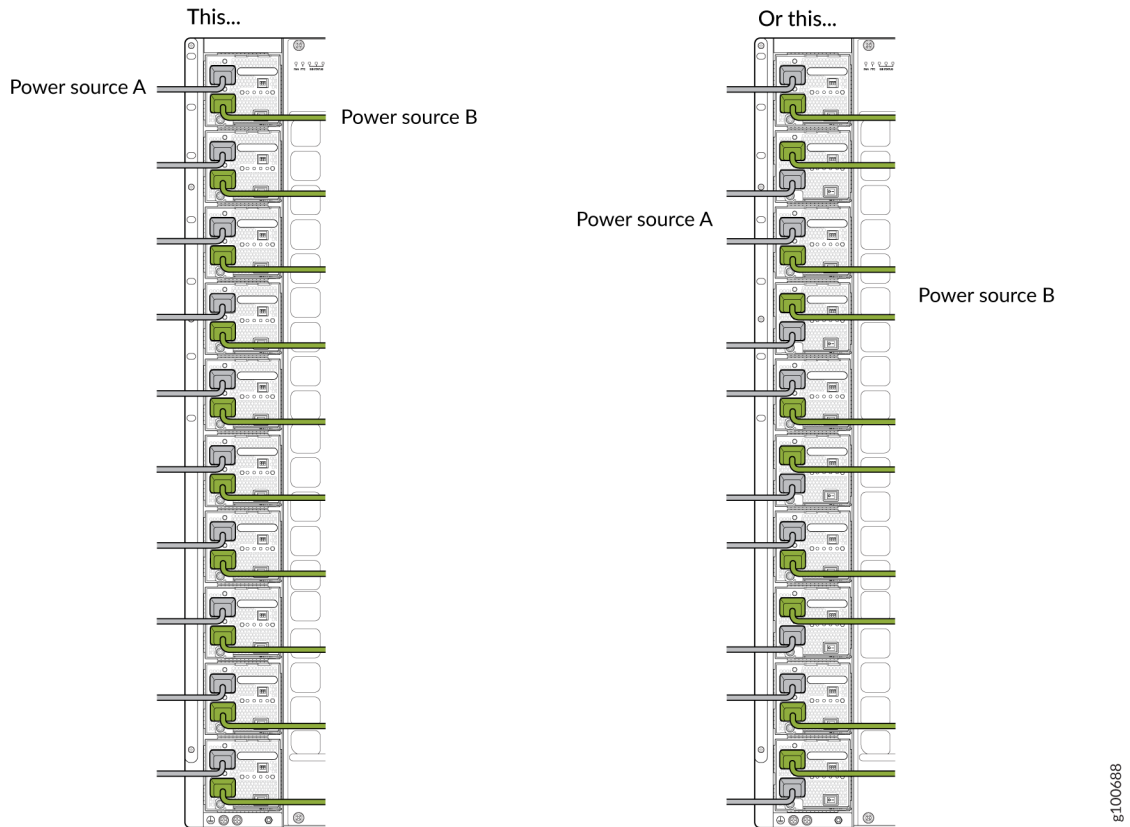

- For each power cable, insert the end of the cable with the Anderson connector into the JNP10K-PWR-AC2 power supply. The connector snaps and locks the cable into position.



WARNING: Ensure that the power cords do not block access to router components or drape where people can trip on them.

- If the AC or DC power source outlets have a power switch, set them to the on (I) position.
- Set the three DIP switches to indicate the number of input sources and to indicate high or low power. See [Table 79 on page 271](#).

Set both enable switches to the **on** position when using both power source inputs. When not using source redundancy, set the unused source to the off (O) position. The LED turns red and indicates an error if a source input is not in use and the enable switch is on (I).

Table 79: Set the JNP10K-PWR-AC2 DIP Switches

Switch	State	Description
1	On	INP0 is present.
	Off	INP0 is not present.
2	On	INP1 is present.
	Off	INP1 is not present.
3	On	Enabled for 30-A feed; 5000 W for single feed, 5500 W for dual feeds.
	Off	Enabled for 20-A feed; power supply capacity is 3000 W.

15. Verify that the **INP1** and **INP2** LEDs on the power supply faceplate are lit and are on steadily.
16. Press the power switch to the on (I) position.

Remove a JNP10K-PWR-AC2 Power Supply

Before you remove an JNP10K-PWR-AC2 power supply from the chassis:

- Ensure you understand how to prevent ESD damage. See "[Prevention of Electrostatic Discharge Damage](#)" on page 388.
- Ensure that you have the following parts and tools available to remove a JNP10K-PWR-AC2 power supply from a PTX10016 router:
 - Heat protective gloves able to withstand temperatures of 158°F (70°C)
 - Electrostatic discharge (ESD) grounding strap
 - Phillips (+) screwdriver, number 1
 - Replacement power supply or a cover for the power supply slot



WARNING: Protect yourself from severe burns by wearing heat-protective gloves when removing a working JNP10K-PWR-AC2 power supply from the chassis. These power supplies can reach temperatures between 158° F to 176° F (70° C to 80° C) under running conditions.



CAUTION: Before you remove a power supply, ensure that you have power supplies sufficient to power the router left in the chassis. See "[Power Requirements for PTX10016 Components](#)" on page 161.



CAUTION: Do not leave the power supply slot empty for a long time while the router is operational. Either replace the power supply promptly or install a cover over the empty slot.

To remove a JNP10K-PWR-AC2 power supply from a PTX10016 router:

1. Wrap and fasten one end of the ESD grounding strap around your bare wrist and connect the other end of the strap to an ESD point on the chassis. There is an ESD point located next to the protective earthing terminal and below **PSU_9** on the rear of the PTX10016 (see [Figure 123 on page 272](#)).

Figure 123: ESD Point on the Rear of the PTX10016 Chassis

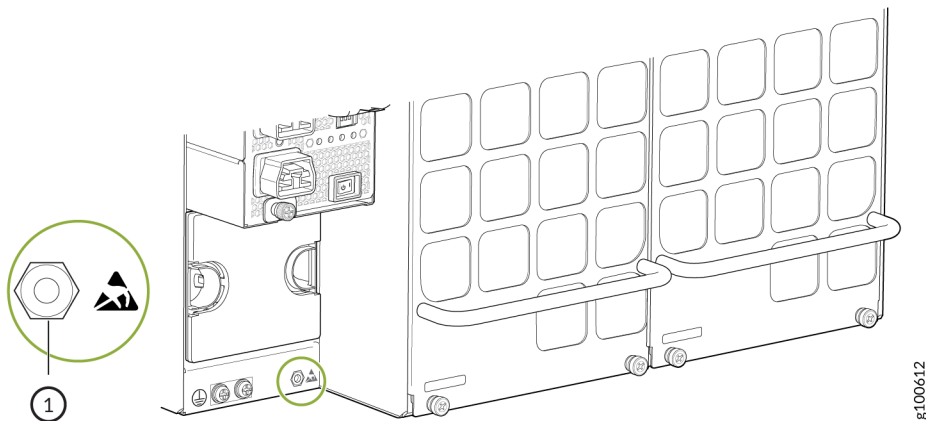

1– ESD point

2. Flip the power (I) switch next to the appliance inlet on the power supply to the standby position (O).
3. If the AC or DC power source outlets have a power switch, set them to the off (O) position.

4. Disconnect the Anderson connectors from each input on the JNP10K-PWR-AC2 power supply faceplate.
5. Unscrew the captive screw counterclockwise by using your fingers or by using the Phillips (+) screwdriver, number 1. See [Figure 124 on page 273](#).

Figure 124: Remove a JNP10K-PWR-AC2 Power Supply from a PTX10016

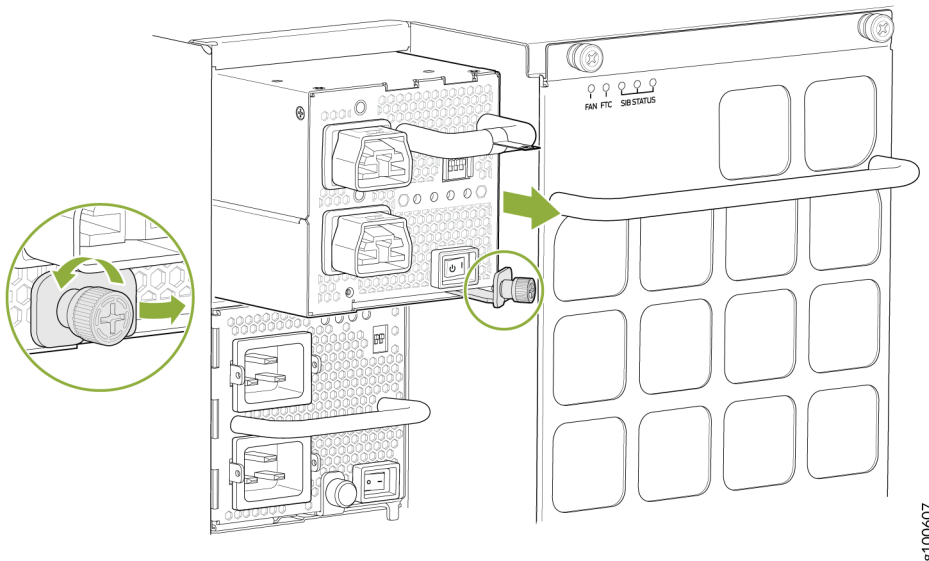

6. Rotate the captive screw away from the faceplate of the power supply to release the latch.
7. Put on your heat protective gloves before removing the power supply from the chassis.
8. Taking care not to touch the power supply output connections, pins, leads, or solder connections, place one hand under the power supply to support it. Grasp the power supply handle with your other hand and pull the power supply completely out of the chassis.



CAUTION: Do not bump the output connections. If the connection hits a solid object, it could damage the power supply.

9. Place the JNP10K-PWR-AC2 power supply on an antistatic surface to completely cool before placing the power supply in an antistatic bag for storage.
10. If you are not replacing the power supply, install the cover over the slot. To install the cover, insert your thumb and forefinger into the finger holes of the cover, squeeze to retract the spring latches, and place the cover in the slot. Do not run the chassis without a power supply or cover in place.

Install a JNP10K-PWR-DC Power Supply

Before you install a JNP10K-PWR-DC power supply in the chassis:

- Ensure that you have followed all safety warnings and cautions:



WARNING: Before performing DC power procedures, ensure that power is removed from the DC circuit. To ensure that all power is off, locate the circuit breaker on the panel board that services the DC circuit, switch the circuit breaker to the off position, and tape the switch handle of the circuit breaker in the off position.



CAUTION: Before you connect power to the router, a licensed electrician must attach a cable lug to the grounding and power cables that you supply. A cable with an incorrectly attached lug can damage the router (for example, by causing a short circuit).



CAUTION: Do not mix AC and DC power supplies in the same chassis.



CAUTION: To meet safety and electromagnetic interference (EMI) requirements and to ensure proper operation, you must connect PTX10016 routers to earth ground before you connect them to power. For installations that require a separate grounding conductor to the chassis, use the protective earthing terminal on the router chassis to connect to earth ground. For instructions on connecting a PTX10016 router to ground using a separate grounding conductor, see "[Connect a PTX10016 Router to Earth Ground](#)" on page 224.

NOTE: The battery returns of the JNP10K-PWR-DC power supply must be connected as an isolated DC return (DC-I).

- Ensure that you have followed all safety warnings and cautions.
- Ensure you understand how to prevent ESD damage. See "[Prevention of Electrostatic Discharge Damage](#)" on page 388.

- Ensure that you have the following parts and tools available to install a JNP10K-PWR-DC power supply:
 - Electrostatic discharge (ESD) grounding strap
 - DC power source cables (not provided) with the cable lugs (provided) attached

The provided Panduit LCD4-14A-L, or equivalent, terminal lugs in a PTX10016 are sized for either 4 AWG (21.1 mm²) or 6 AWG (13.3 mm²) power source cables. When using all JNP10K-PWR-DC power supplies in the chassis, the DC power source cables that you provide must be 6 AWG (13.3 mm²) stranded wire. We recommend that you install heat-shrink tubing insulation around the crimped section of the power cables and lugs.

NOTE: If you upgrade the JNP10K-PWR-DC to a JNP10K-PWR-DC2 and set the input mode to high (80 A), you must use 4 AWG (21.1 mm²) stranded wire. The 4 AWG (21.1 mm²) stranded wire should be rated 75° C, or per local electrical code.

NOTE: See the heat symbol



. Wear heat-resistant gloves while accessing the fan tray and power supply.

- 13/32 in. (10 mm) nut driver or socket wrench
- Phillips (+) screwdrivers, numbers 1 and 2
- Multimeter
- Heat resistant gloves

To install a JNP10K-PWR-DC power supply in a PTX10016 router:

1. Wrap and fasten one end of the ESD grounding strap around your bare wrist and connect the other end of the strap to an ESD point on the chassis. There is an ESD point located next to the

protective earthing terminal and below **PSU_9** on the rear of the PTX10016I (see [Figure 125](#) on [page 276](#)).

Figure 125: ESD Point on the Rear of the PTX10016 Chassis

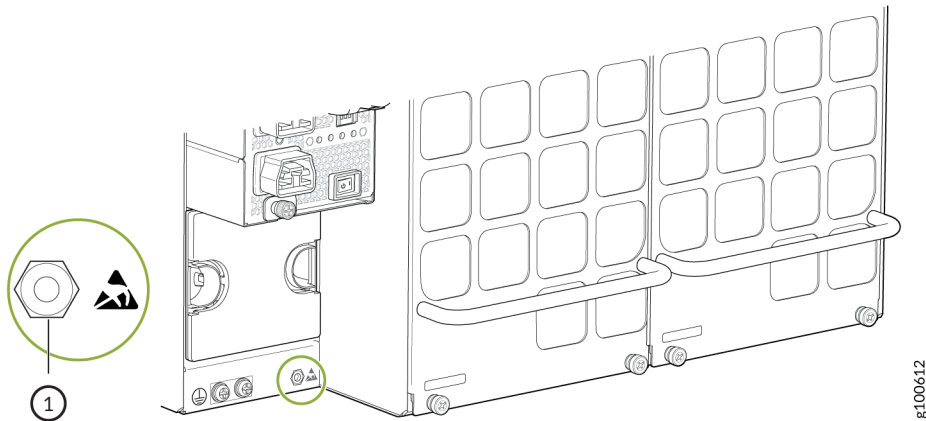

1– ESD point

2. Taking care not to touch power supply components, pins, leads, or solder connections, remove the power supply from its bag.



CAUTION: See the heat symbol



. The power supply surfaces are hot. Allow a few minutes for the power supply to cool by pulling the power supply halfway out of the chassis, or wear heat-resistant gloves while removing the power supply.

3. Peel back and remove the protective plastic wrap that covers all four sides of the power supply.
4. Ensure the power switch is set to the standby (O) position. This switch turns off the output voltage; it does not interrupt DC.

- Remove the plastic cable cover from the DC power input terminals, using the Phillips (+) screwdriver, number 2, to loosen the screws (see [Figure 126 on page 277](#)).

Figure 126: Remove the Plastic Cable Cover on a JNP10K-PWR-DC Power Supply

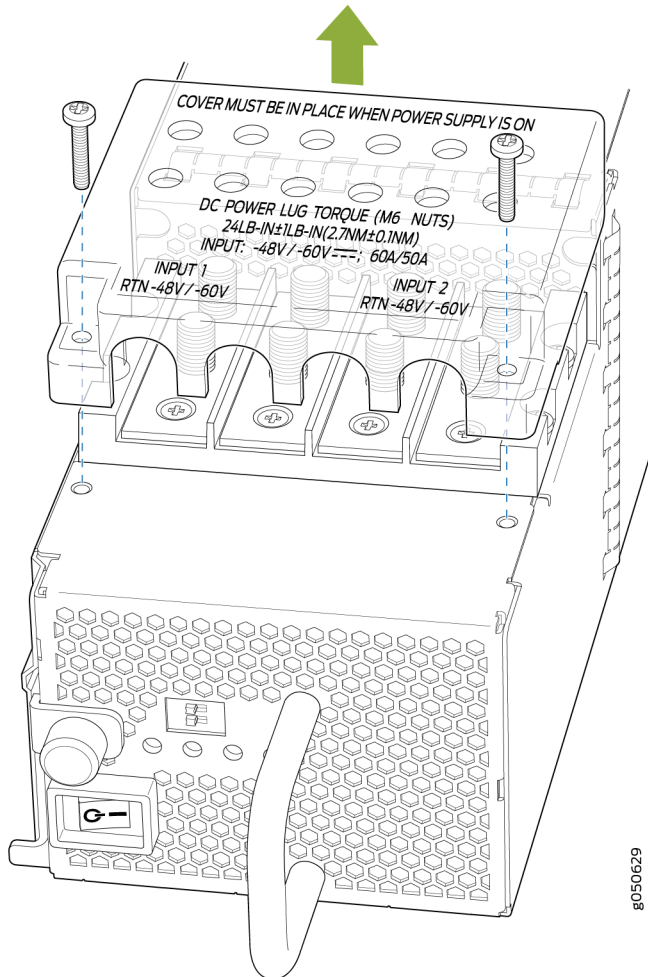

- Remove the nuts from each DC power input terminal, using the 13/32 in. (10 mm) nut driver or socket wrench to loosen the nuts.
- Ensure that the power source circuit breaker is open so that the voltage across the DC power source cable leads is 0 V and that the cable leads do not become active while you are connecting DC power.
- Install a power lug on each DC power cable. Ensure the lug meets the double-hole standard lug terminal for 4 AWG wire. The lugs should be dual, 1/4 in. spaced 5/8 in. apart. The terminal must accommodate double-hole standard lug terminal for 4 AWG or larger wire.
- Verify that the DC power cables are correctly labeled before making connections to the power supply. In a typical power distribution scheme where the return is connected to chassis ground at

the battery plant, you can use a multimeter to verify the resistance of the **-48V** and **RTN** DC cables to chassis ground:

- The cable with very high resistance (indicating an open circuit) to chassis ground is negative (-) and will be installed on the **-48V** (input) DC power input terminal.
- The cable with very low resistance (indicating a closed circuit) to chassis ground is positive (+) and will be installed on the **RTN** (return) DC power input terminal.



CAUTION: You must ensure that power connections maintain the proper polarity. The power source cables might be labeled **(+)** and **(-)** to indicate their polarity. There is no standard color coding for DC power cables.

10. Install each power cable lug on the DC power input terminal, securing it with the nut (see [Figure 127 on page 279](#)). Apply between 23 lb-in. (2.6 Nm) and 25 lb-in. (2.8 Nm) of torque to each nut. (Use the 13/32 in. [10 mm] nut driver or socket wrench.)
 - a. Secure each positive **(+)** DC source power cable lug to the **RTN** (return) DC power input terminal.

- b. Secure each negative (-) DC source power cable lug to the **-48V** (input) DC power input terminal.

Figure 127: Connect the DC Power Source Cables to a JNP10K-PWR-DC Power Supply

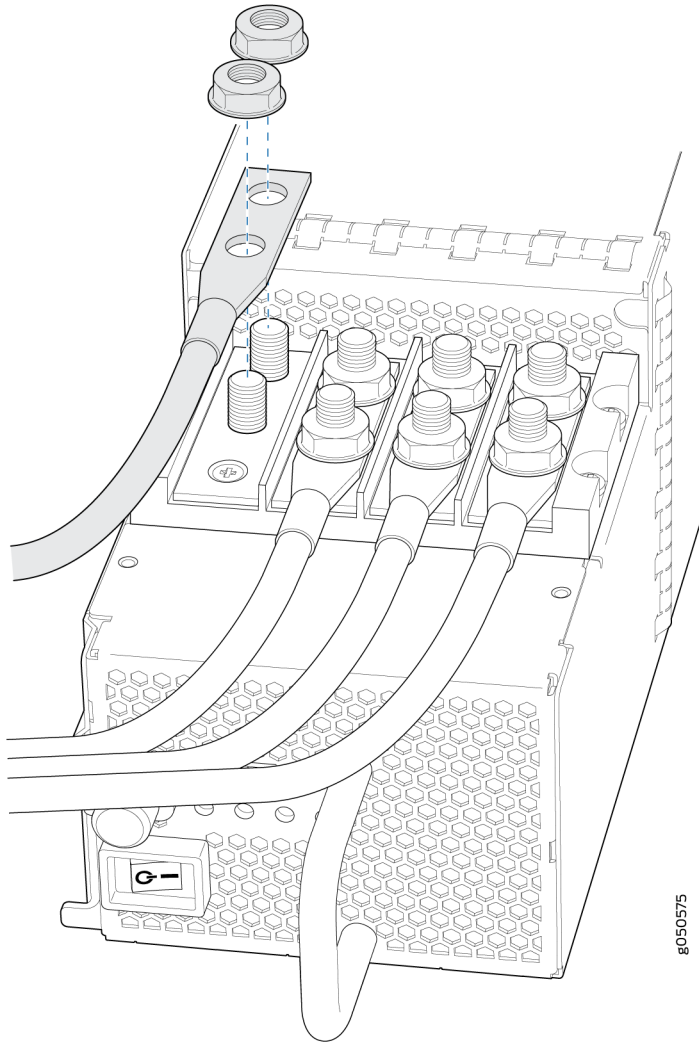

Each power supply has two independent sets of DC power input terminals (**INPUT 1: RTN -48V/-60V:** and **INPUT 2: : RTN -48V/-60V**). For feed redundancy, each power supply must be powered by dedicated power feeds derived from feed **INPUT 1** and feed **INPUT 2**. This configuration provides the commonly deployed **INPUT 1 / INPUT 2** feed redundancy for the router. There is basic insulation between the inputs and the chassis ground. Also, there is basic insulation between RTN input feeds.

11. Install the plastic cable cover over each set of power cables by using the Phillips (+) screwdriver, number 2, to tighten the screw.

12. If the power supply slot on the chassis has a cover on it, insert your thumb and forefinger into the finger holes, squeeze, and pull the cover out of the slot. Save the cover for later use (see [Figure 128 on page 280](#)).

Figure 128: Remove the Power Supply Cover on a PTX10016

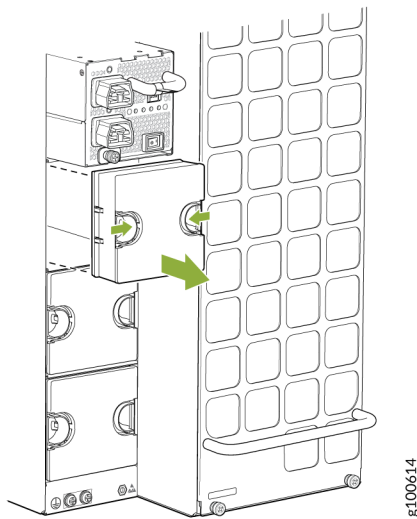

13. Unscrew the captive screw in the counterclockwise direction by using your fingers or by using the Phillips (+) screwdriver, number 1.
14. Pull the captive screw away from the faceplate of the power supply to release the latch.

NOTE: You can install the power supplies in any slot labeled **PSU 0** through **PSU 9** (top to bottom) on a PTX10016.

15. Using both hands, place the power supply in the power supply slot on the rear of the router.
16. Slide the power supply straight into the chassis until the power supply is fully seated in the slot. Ensure the power supply faceplate is flush with any adjacent power supply faceplates or power supply covers (see and [Figure 129 on page 281](#)).
17. Push the captive screw into the power supply faceplate. Ensure that the screw is seated inside the corresponding hole on the faceplate.

- 18. Tighten the captive screw by turning it clockwise by using your fingers or by using the Phillips (+) screwdriver, number 1. Do not overtighten—do not apply more than 7.3 lb-in (0.82 Nm) of torque to the screws. When the screw is completely tight, the latch locks into the router chassis.

Figure 129: Install a JNP10K-PWR-DC Power Supply in a PTX10016

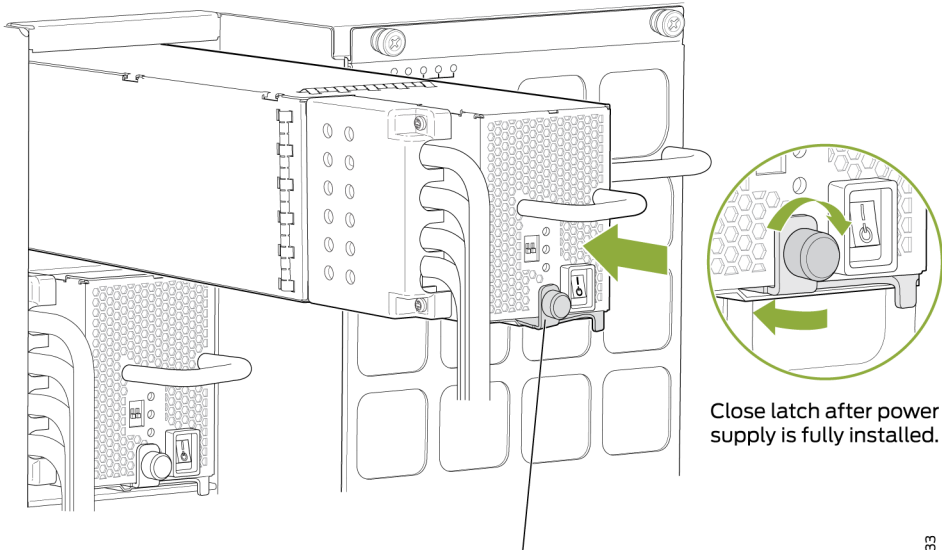

Keep latch in open position during installation.

8050733

NOTE: Ensure that the ejector is fully open to avoid scratching the chassis.

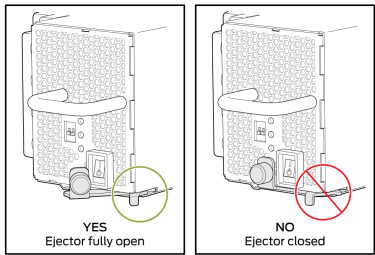

8010446

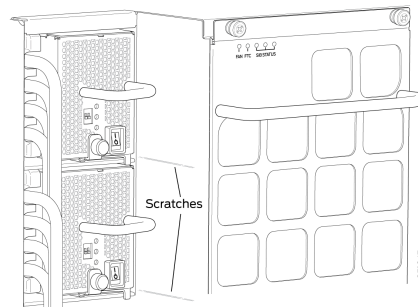

8010447

19. Route input 1 cables to a power source and input 2 cables to another power source. The JNP10K-PWR-DC shares power, so if power dips on one input, the power supply is able to load-balance internally. See [Figure 130 on page 282](#).

Figure 130: Proper Load Balancing for JNP10K-PWR-DC Power Cables on a PTX100016

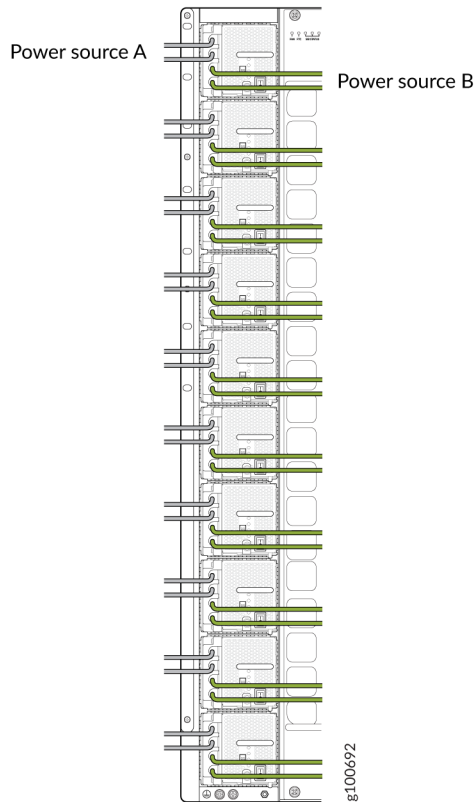

WARNING: Ensure that the power cords do not block access to router components or drape where people can trip on them.

20. Set the enable switches for input 1 and input 2 (see [Figure 131 on page 283](#)).

Set both enable switches to the on (I) position when using both source inputs. When not using source redundancy, set the unused source to the off (O) position. The LED turns red and indicates an error if a source input is not in use and the enable switch is on (I).

Figure 131: Set the Enable Switches for the Power Source

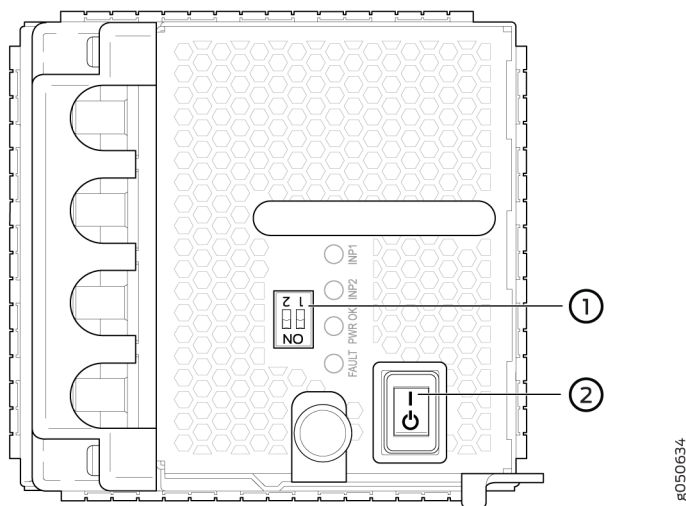

1– DIP switches for enabling input sources

2– Power switch, on (I) and standby (O)

21. Verify that the input 1 and 2 LEDs on the power supply faceplate are lit and are on steadily.
22. Press the power switch to the on (I) position.

Remove a JNP10K-PWR-DC Power Supply

Before you remove a JNP10K-PWR-DC power supply from the router:

- Ensure you understand how to prevent ESD damage. See ["Prevention of Electrostatic Discharge Damage" on page 388](#).
- Ensure that you have the following parts and tools available to remove a JNP10K-PWR-DC power supply:
 - Electrostatic discharge (ESD) grounding strap
 - Phillips (+) screwdriver, numbers 1 and 2
 - 13/32 in. (10 mm) nut driver or socket wrench
 - Replacement power supply or a cover for the power supply slot



CAUTION: Before you remove a power supply, ensure that you have power supplies sufficient to power the router left in the chassis. See "[Power Requirements for PTX10016 Components](#)" on page 161.



WARNING: Before performing DC power procedures, ensure that power is removed from the DC circuit. To ensure that all power is off, locate the circuit breaker on the panel board that services the DC circuit, switch the circuit breaker to the off (O) position, and tape the switch handle of the circuit breaker in the off position.



CAUTION: Do not leave the power supply slot empty for a long time while the router is operational. Either replace the power supply promptly or install a cover over the empty slot.

To remove a JNP10K-PWR-DC power supply from a PTX10016 router:

1. Wrap and fasten one end of the ESD grounding strap around your bare wrist and connect the other end of the strap to an ESD point on the chassis. There is an ESD point located next to the protective earthing terminal and below **PSU_9** on the PTX10016 (see [Figure 132 on page 284](#)).

Figure 132: ESD Point on the Rear of the PTX10016 Chassis

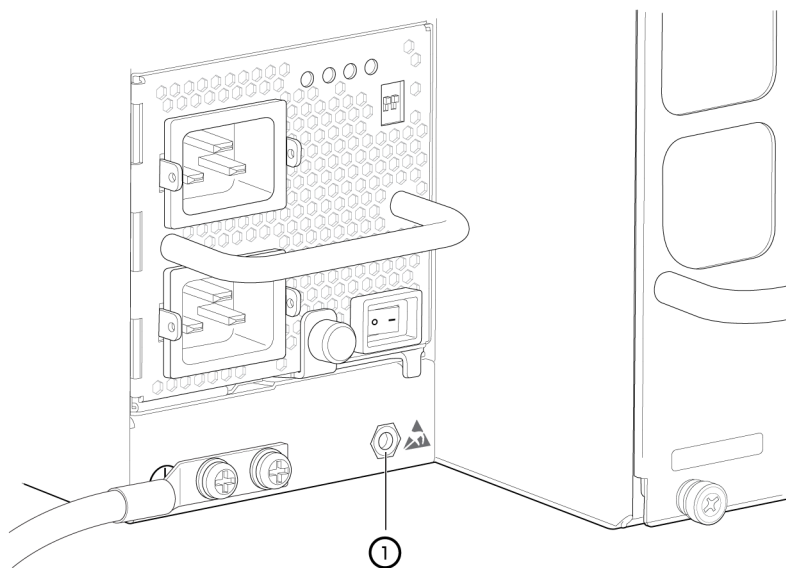

8050729

1- ESD point

2. Make sure that the voltage across the DC power source cables leads is 0 V and that there is no chance that the cables might become active during the removal process.
3. Ensure the black power supply output switch, to the right of the captive screw, is set to the standby position (O).
4. Unscrew the captive screw counterclockwise by using your fingers or by using the Phillips (+) screwdriver, number 1.
5. Rotate the captive screw away from the faceplate of the power supply to release the latch. See [Figure 133 on page 285](#).

Figure 133: Remove a JNP10K-PWR-DC Power Supply from a PTX10016

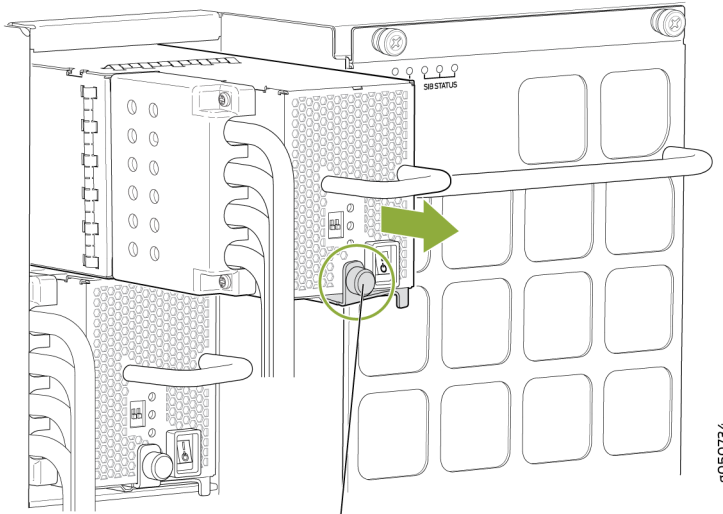

Keep latch in open position during removal.

NOTE: Ensure that the ejector is fully open to avoid scratching the chassis.

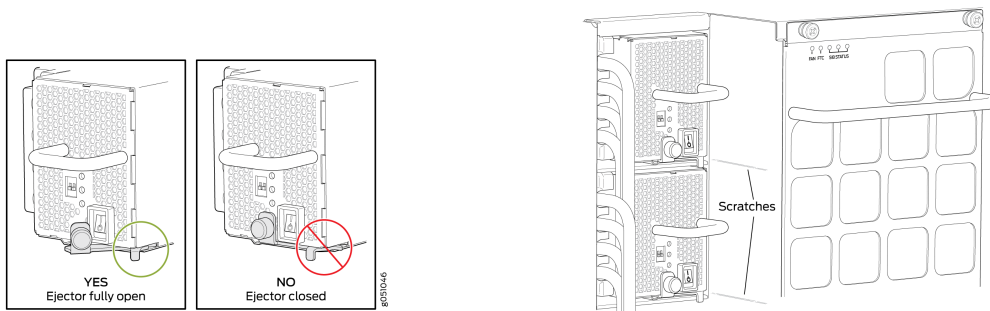

6. Put on the heat resistant gloves to protect your hands from the hot power supply.
7. Taking care not to touch power supply components, pins, leads, or solder connections, place one hand under the power supply to support it. Grasp the power supply handle with your other hand and pull the power supply completely out of the chassis.



CAUTION: See the heat symbol



. The power supply surfaces are hot. Allow a few minutes for the power supply to cool by pulling the power supply halfway out of the chassis, or wear heat-resistant gloves while removing the power supply.

8. If you are not replacing the power supply, install the cover over the slot. To install the cover, insert your thumb and forefinger into the finger holes of the cover, squeeze to retract the spring latches, and place the cover in the slot. Do not run the chassis without a power supply or cover in place.
9. Unscrew the screw on the plastic cable cover that shields the input terminal studs counterclockwise by using the number 2 Phillips (+) screwdriver.
10. Unscrew the nuts counterclockwise, using the 13/32 in. (10 mm) nut driver or socket wrench, from the input terminal studs.
11. Remove the cable lugs from the input terminal studs.

Install a JNP10K-PWR-DC2 Power Supply

Before you install a JNP10K-PWR-DC2 power supply in the chassis:

- Ensure that you have followed all safety warnings and cautions:



WARNING: Before performing DC power procedures, ensure that power is removed from the DC circuit. To ensure that all power is off, locate the circuit breaker on the panel board that services the DC circuit, switch the circuit breaker to the off (O) position, and tape the switch handle of the circuit breaker in the off position.



WARNING: Protect yourself from severe burns by wearing heat-protective gloves when removing a working HVDC power supply from the chassis. HVDC power supplies can reach temperatures between 158°F to 176°F (70°C to 80°C) under running conditions.



CAUTION: Before you connect power to the router, a licensed electrician must attach a cable lug to the grounding and power cables that you supply. A cable with an incorrectly attached lug can damage the router (for example, by causing a short circuit).



CAUTION: Use the same type of power supply in all slots. Do not mix power supply models in a production chassis.



CAUTION: To meet safety and electromagnetic interference (EMI) requirements and to ensure proper operation, you must connect PTX10016 routers to earth ground before you connect them to power. For installations that require a separate grounding conductor to the chassis, use the protective earthing terminal on the router chassis to connect to earth ground. For instructions on connecting a PTX10016 router to ground using a separate grounding conductor, see "[Connect a PTX10016 Router to Earth Ground](#)" on page 224.

NOTE: The battery returns of the JNP10K-PWR-DC2 power supply must be connected as an isolated DC return (DC-I).

- Ensure you understand how to prevent ESD damage. See "[Prevention of Electrostatic Discharge Damage](#)" on page 388.

- Ensure that you have the following parts and tools available to install a DC power supply:
 - Heat-protective gloves, such as welders gloves, that are able to withstand temperatures up to 176°F (80°C)
 - Electrostatic discharge (ESD) grounding strap
 - Use high-current cable assembly, CBL-PWR2-BARE (not provided) with the cable lugs (provided) attached.

The provided terminal lugs for the JNP10K-PWR-DC2 are Panduit LCD4-14A-L, or equivalent, and sized for 4 AWG (21.1 mm²) power source cables. The 4 AWG (21.1 mm²) stranded wire should be rated 75° C, or per local electrical code. We recommend that you install heat-shrink tubing insulation around the crimped section of the power cables and lugs.

- 13/32 in. (10 mm) nut driver or socket wrench
- Phillips (+) screwdrivers, numbers 1 and 2
- Multimeter

To install a JNP10K-PWR-DC2 power supply in a PTX10016:

1. Wrap and fasten one end of the ESD grounding strap around your bare wrist and connect the other end of the strap to an ESD point on the chassis. There is an ESD point located next to the protective earthing terminal and below **PSU_9** on the rear of the PTX10016 (see [Figure 134 on page 288](#)).

Figure 134: ESD Point on the Rear of the PTX10016 Chassis

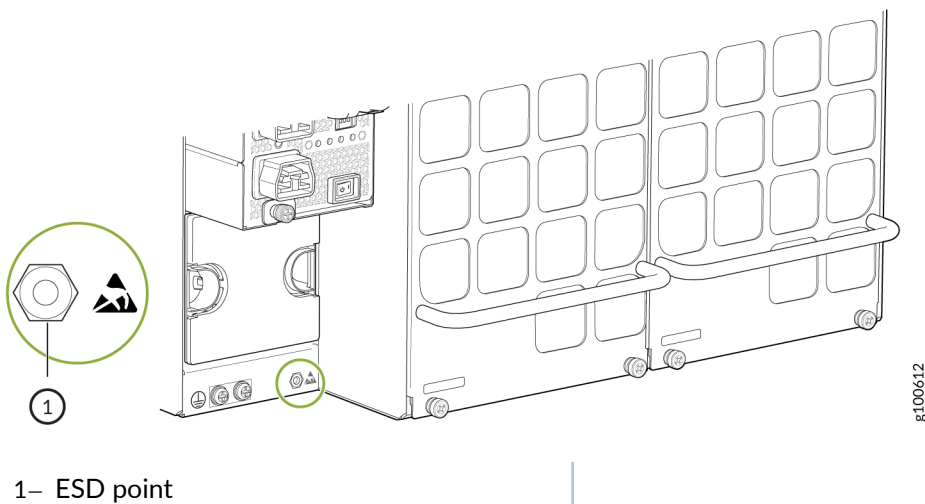

2. Taking care not to touch power supply components, pins, leads, or solder connections, remove the power supply from its bag.
3. Peel back and remove the protective plastic wrap that covers all four sides of the power supply.
4. Ensure the power switch is set to the standby (O) position. This switch turns off the output voltage; it does not interrupt DC.
5. Remove the plastic cable cover from the power input terminals, by using the Phillips (+) screwdriver, number 2, to loosen the screws (see [Figure 135 on page 289](#)).

Figure 135: Remove the Plastic Cable Cover on a JNP10K-PWR-DC2 Power Supply

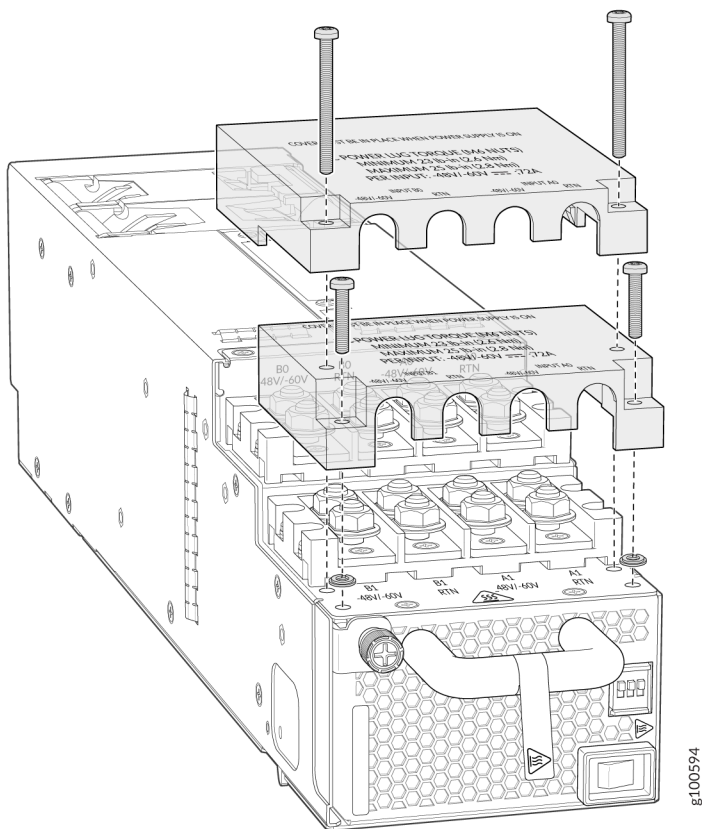

6. Remove the nuts from each DC power input terminal, using the 13/32 in. (10 mm) nut driver or socket wrench to loosen the nuts.
7. Ensure that the power source circuit breaker is open so that the voltage across the DC power source cable leads is 0 V and that the cable leads do not become active while you are connecting DC power.
8. Verify that the DC power cables are correctly labeled before making connections to the power supply. In a typical power distribution scheme where the return is connected to chassis ground at

the battery plant, you can use a multimeter to verify the resistance of the **-48V** and **RTN** DC cables to chassis ground:

- The cable with very high resistance (indicating an open circuit) to chassis ground is negative (-) and will be installed on the **-48V** (input) DC power input terminal.
- The cable with very low resistance (indicating a closed circuit) to chassis ground is positive (+) and will be installed on the **RTN** (return) DC power input terminal.

The JNP10K-PWR-DC2 power supply is the equivalent of two power supplies in a single housing. Each JNP10K-PWR-DC2 has four independent sets of DC power input terminals:

- **A0: INPUT A0 RTN -48V/-60V**
- **B0: INPUT B0 RTN -48V/-60V**
- **A1: INPUT A1 RTN -48V/-60V**
- **B1: INPUT B1 RTN -48V/-60V**

We recommend source redundancy (source A and source B) to all inputs to ensure reliability of the system. If you not have two power sources available, then having two feeds from the same source provides power distribution reliability because there are two independent power distribution from the source to the system. See

Figure 136: JNP10K-PWR-DC2 Input Terminal Marking

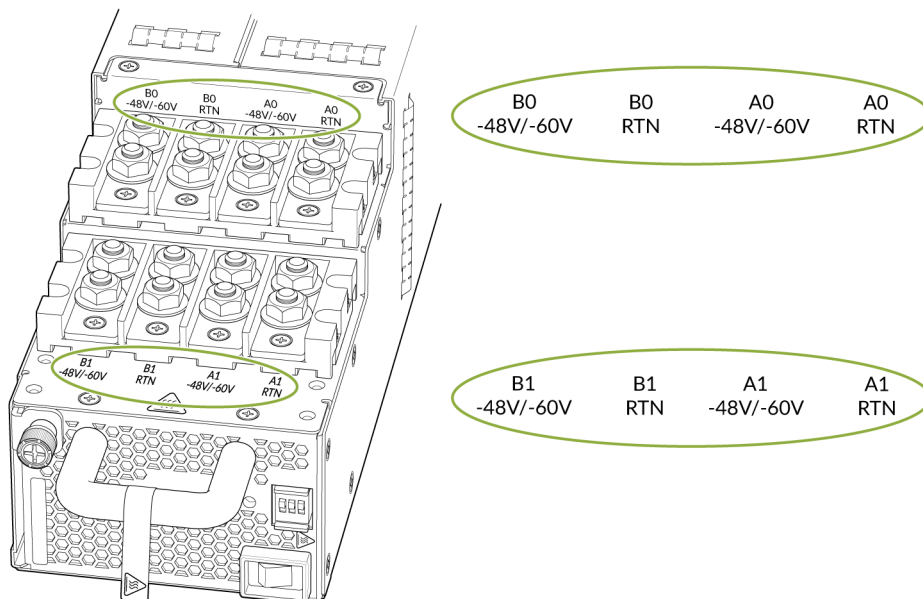



CAUTION: You must ensure that power connections maintain the proper polarity. The power source cables might be labeled **(+)** and **(-)** to indicate their polarity. There is no standard color coding for DC power cables.

We recommend source redundancy (source A and source B) to all inputs to ensure reliability of the system. If you not have two power sources available, then having two feeds from the same source provides power distribution reliability because there are two independent power distribution from the source to the system. See .

9. Install each power cable lug on the DC power input terminal, securing it with the nut (see [Figure 137 on page 292](#)). Apply between 23 lb-in. (2.6 Nm) and 25 lb-in. (2.8 Nm) of torque to each nut. (Use the 13/32 in. [10 mm] nut driver or socket wrench.)
 - a. Secure each positive **(+)** DC source power cable lug to the **RTN** (return) DC power input terminal.
 - b. Secure each negative **(-)** DC source power cable lug to the **-48V** (input) DC power input terminal.

Each power supply has two independent sets of DC power input terminals (**INPUT 1: RTN -48V/-60V:** and **INPUT 2: : RTN -48V/-60V**). For feed redundancy, each power supply must be powered by dedicated power feeds derived from feed **INPUT 1** and feed **INPUT 2**. This configuration provides the commonly deployed INPUT 1 / INPUT 2 feed redundancy for the router. There is basic

insulation between the inputs and the chassis ground. Also, there is basic insulation between RTN input feeds.

Figure 137: Connect the DC Power Source Cables to a JNP10K-PWR-DC2 Power Supply

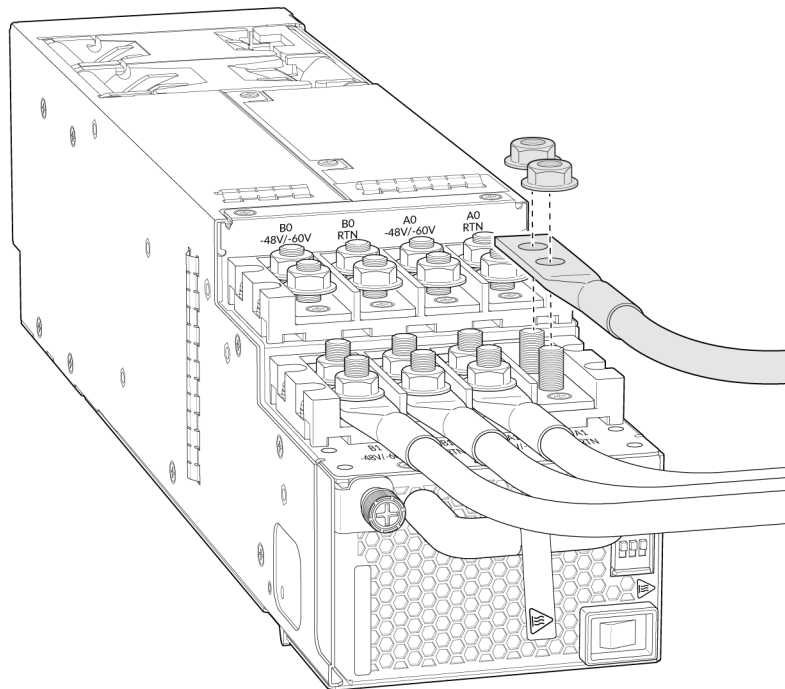

10. Install the plastic cable cover over each set of power cables by using the Phillips (+) screwdriver, number 2, to tighten the screw.

11. If the power supply slot on the chassis has a cover on it, insert your thumb and forefinger into the finger holes, squeeze, and pull the cover out of the slot. Save the cover for later use (see [Figure 138 on page 293](#)).

Figure 138: Remove the Power Supply Cover on a PTX10016

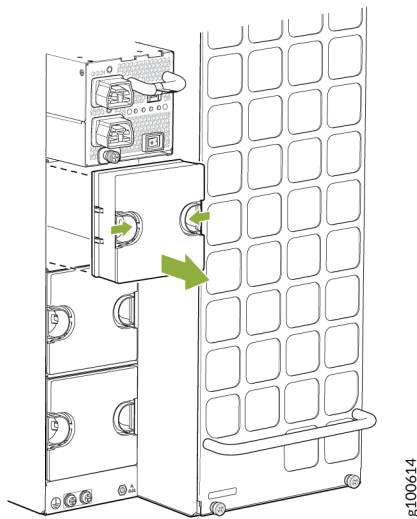

12. Unscrew the captive screw in the counterclockwise direction by using your fingers or by using the Phillips (+) screwdriver, number 1.
13. Rotate the captive screw away from the faceplate of the power supply to release the latch.
14. Using both hands, place the power supply in the power supply slot on the rear of the router. Slide the power supply straight into the chassis until the power supply is fully seated in the slot. The power supply will protrude from the chassis about 2 in. (5 cm) (see [Figure 139 on page 294](#)).
15. Push the captive screw into the power supply faceplate. Ensure that the screw is seated inside the corresponding hole on the faceplate.

16. Tighten the captive screw by turning it clockwise by using your fingers or by using the Phillips (+) screwdriver, number 1. Do not overtighten—do not apply more than 7.3 lb-in (0.82 Nm) of torque to the screws. When the screw is completely tight, the latch locks into the router chassis.

Figure 139: Install a JNP10K-PWR-DC2 Power Supply in a PTX10016

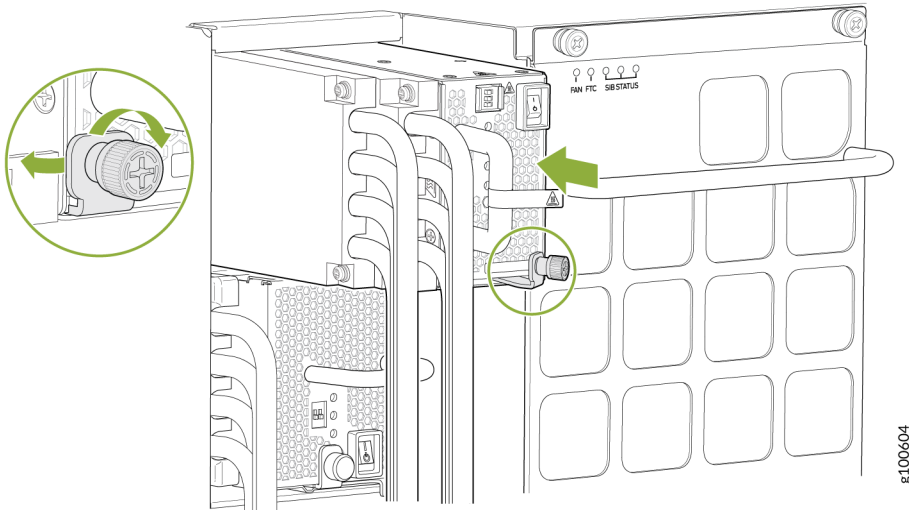

17. Route input A0 and B0 cables to a power source and input A1 and B1 cables to another power source. The JNP10K-PWR-DC shares power, so if power dips on one input, the power supply is able to load-balance internally. See [Figure 140 on page 295](#).

Figure 140: Proper Load Balancing for JNP10K-PWR-DC2 Power Cables on a PTX100016

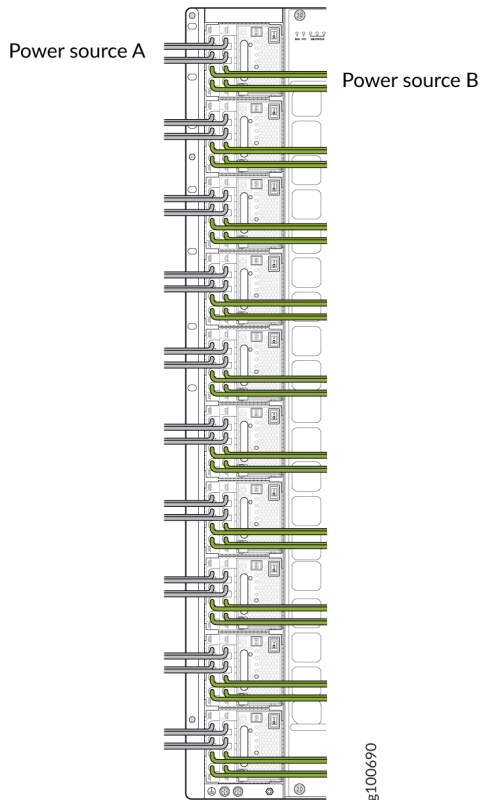

WARNING: Ensure that the power cords do not block access to router components or drape where people can trip on them.

18. Set the three DIP switches to indicate the number of input sources and to indicate high or low power. See [Table 80 on page 296](#) and [Figure 141 on page 296](#).
Set both enable switches to the **on** position when using both source inputs. When not using source redundancy, set the unused source to the off position. The LED turns red and indicates an error if a source input is not in use and the enable switch is **on**.

Table 80: Set the JNP10K-PWR-DC2 DIP Switches

Switch	State	Description
1	On	IP0 is present.
	Off	IP0 is not present.
2	On	IP1 is present.
	Off	IP1 is not present
3	On	Enabled for 30-A feed; 5000 W for a single feed, 5500 W for dual feeds.
	Off	Enabled for 20-A feed; power supply capacity is 3000 W.

Figure 141: Set the Enable Switches for the Power Source

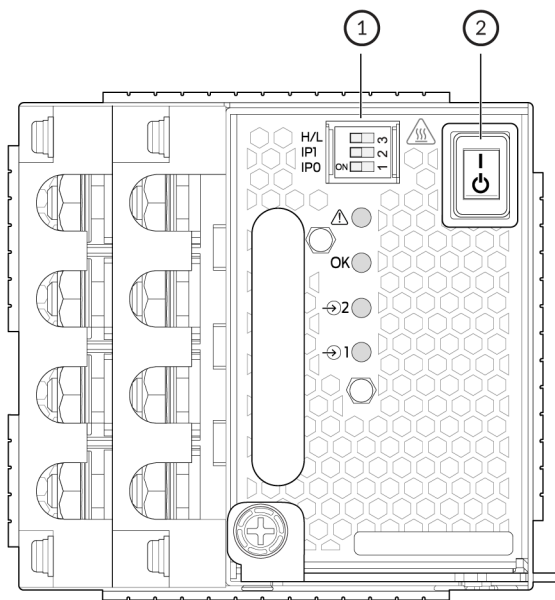

8100597

1– DIP switches

2– Power switch, on (I) and standby (O)

19. Verify that the input 1 and 2 LEDs on the power supply faceplate are lit and are on steadily.
20. Press the power switch to the on (I) position.

Remove a JNP10K-PWR-DC2 Power Supply

Before you remove a JNP10K-PWR-DC2 power supply from the router:

- Ensure that you have followed all safety warnings and cautions:



CAUTION: A working JNP10K-PWR-DC2 power supply can reach temperatures between 158°F to 176°F (70°C to 80°C) under running conditions. In order to avoid injury, do not touch a running power supply with your bare hands.



- Ensure you understand how to prevent ESD damage. See ["Prevention of Electrostatic Discharge Damage"](#) on page 388.



CAUTION: Before you remove a power supply, ensure that you have power supplies sufficient to power the router left in the chassis. See ["Power Requirements for PTX10016 Components"](#) on page 161.



CAUTION: Do not leave the power supply slot empty for a long time while the router is operational. Either replace the power supply promptly or install a cover over the empty slot.

- Ensure that you have the following parts and tools available to remove a JNP10K-PWR-DC2 power supply:
 - Heat protective gloves, such as welders gloves, that are able to withstand temperatures between 158°F to 176°F (70°C to 80°C)
 - Electrostatic discharge (ESD) grounding strap

- Phillips (+) screwdriver, numbers 1 and 2
- 13/32 in. (10 mm) nut driver or socket wrench
- Replacement power supply or a cover for the power supply slot

To remove a JNP10K-PWR-DC2 power supply from a PTX10016 router:

1. Wrap and fasten one end of the ESD grounding strap around your bare wrist and connect the other end of the strap to an ESD point on the chassis. There is an ESD point located next to the protective earthing terminal and below **PSU_9** on the PTX10016 (see [Figure 142 on page 298](#)).

Figure 142: ESD Point on the Rear of the PTX10016

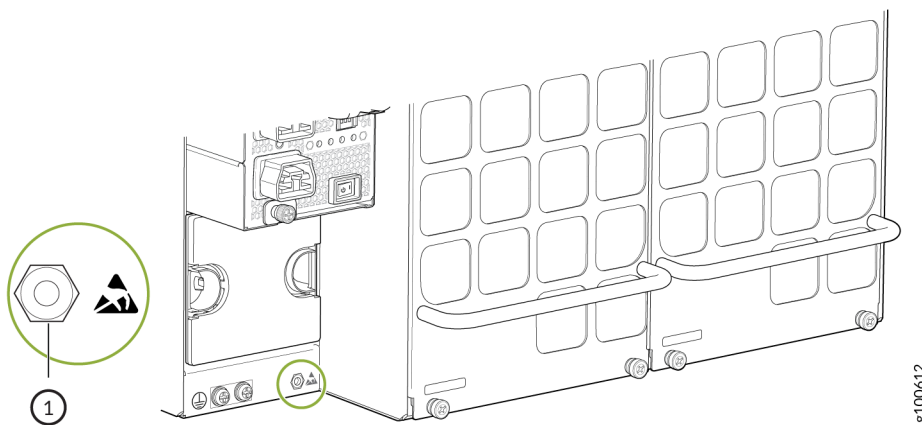

1– ESD point

2. Make sure that the voltage across the DC power source cables leads is 0 V and that there is no chance that the cables might become active during the removal process.
3. Ensure the black power supply output switch, to the right of the captive screw, is set to the standby (O) position.
4. Unscrew the captive screw counterclockwise by using your fingers or by using the Phillips (+) screwdriver, number 1.

5. Rotate the captive screw away from the faceplate of the power supply to release the latch. (See [Figure 143 on page 299.](#))

Figure 143: Remove a JNP10K-PWR-DC2 Power Supply on PTX10016

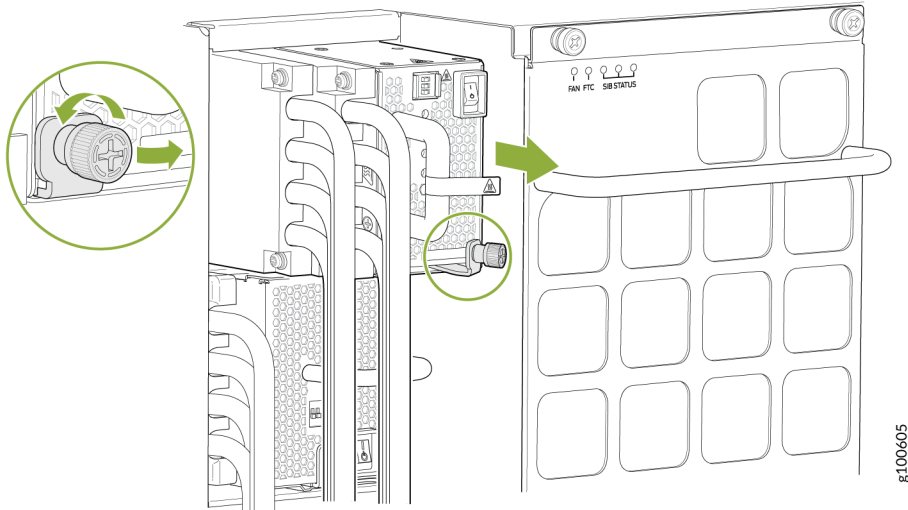

6. Wear the heat-resistant gloves to protect your hands from the hot power supply.
7. Taking care not to touch power supply components, pins, leads, or solder connections, place one gloved hand under the power supply to support it. Grasp the power supply handle with your other hand and pull the power supply completely out of the chassis.
8. If you are not replacing the power supply, install the cover over the slot.
 - a. Insert your thumb and forefinger into the finger holes of the cover.
 - b. Squeeze and place the cover in the slot.
 - c. Release your fingers and the cover remains in the slot.
9. Unscrew the screw on the plastic cable cover that shields the input terminal studs counterclockwise by using the Phillips (+) screwdriver, number 2.
10. Unscrew the nuts counterclockwise using the 13/32 in. (10 mm) nut driver or socket wrench, from the input terminal studs.
11. Remove the cable lugs from the input terminal studs.

Install and Remove PTX10016 Switch Fabric Components

IN THIS SECTION

- [How to Handle and Store PTX10016 Line Cards, RCBs, and SIBs | 300](#)
- [How to Hold Line Cards and RCBs | 300](#)
- [How to Hold SIBs | 302](#)
- [How to Store Line Cards, RCBs, and SIBs | 303](#)
- [Install a PTX10016 Switch Interface Board | 303](#)
- [Remove a PTX10016 Switch Interface Board | 307](#)

Each PTX10016 router contains five or six Switch Interface Boards (SIBs) that are installed vertically, mid-chassis, between the line cards and the Routing and Control Boards (RCBs) in the front and the fan trays in the rear. To install or remove the SIBs in a PTX10016 router, read the following sections:

How to Handle and Store PTX10016 Line Cards, RCBs, and SIBs

The PTX10016 chassis have several field-replaceable units (FRUs) that have fragile components. To avoid damaging the line cards, Routing and Control Boards (RCBs), and Switch Interface Boards (SIBs), be sure you follow the following safe handling practices.

How to Hold Line Cards and RCBs

Pay proper attention to the way you are holding line cards and RCBs. Line cards and RCBs are installed horizontally and it is best to hold them by the sides of the units when they are not in the chassis.

When walking with a line card or RCB:

1. Orient the line card or the RCB so that the faceplate is toward you.
2. Grasp each side of the unit firmly as you slide the unit out of the chassis.
3. Take care not to strike the unit against any object as you carry it.



CAUTION: Never hold the line card or RCB by the connector edge. The connectors are fragile and the line card or RCB will not seat properly if the connector is damaged. See [Figure 144 on page 301](#).

Figure 144: Connector Edge of a Line Card

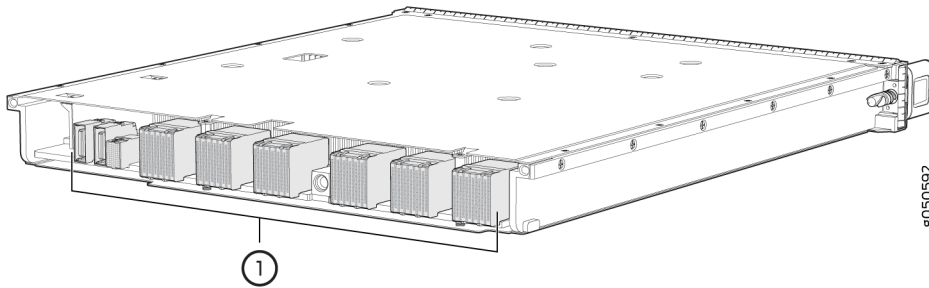

1- Connectors

4. If you must rest a line card or an RCB on an edge, place a cushion between the edge and the surface.



CAUTION: Do not stack line cards or RCBs on top of one another or on top of any other component.

5. Place each line card separately in an antistatic bag or on an antistatic mat placed on a flat, stable surface.

How to Hold SIBs

SIBs are installed vertically and should be held vertically until they are clear of the router before rotating them 90 degrees and placing them on an antistatic mat or placing them in an antistatic bag for storage. See [Figure 145 on page 302](#).

Figure 145: PTX10016 Switch Interface Board (SIB)

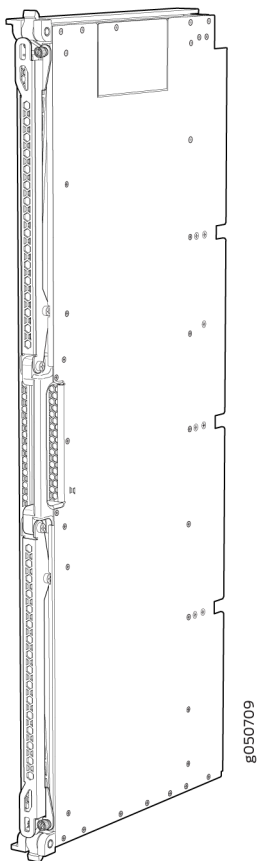

The proper method of holding a SIB is to:

1. Hold the SIB by the ejectors while you keep the SIB vertical, and slide the SIB about three-quarters of the way out of the chassis.
2. Place one hand underneath the SIB to support it, and slide it completely out of the chassis.



CAUTION: Never hold the SIB by the connector edge. The connectors are fragile and the SIB will not align and seat properly if the connector is damaged.



CAUTION: Do not stack SIBs on top of one another or on top of any other component.

How to Store Line Cards, RCBs, and SIBs

You must store line cards, RCBs, and SIBs either in the chassis or in a spare shipping container, horizontally and sheet metal side down. Do not stack these units on top of one another or on top of any other component. Place each unit separately in an antistatic bag or on an antistatic mat placed on a flat, stable surface.

NOTE: Because these units are heavy, and because antistatic bags are fragile, inserting the line card into the bag is best done with two people.

To insert a line card, RCB, or SIB into an antistatic bag:

1. Hold the unit horizontally with the faceplate toward you.
2. Slide the opening of the bag over the connector edge.

If you must insert the line card, RCB, or SIB into a bag by yourself:

1. Lay the unit horizontally on an antistatic mat that is on a flat, stable surface with the sheet metal side down.
2. Orient the unit with the faceplate toward you.
3. Carefully insert the connector edge into the opening of the bag and pull the bag toward you to cover the unit.

Install a PTX10016 Switch Interface Board

A PTX10016 router has six Switch Interface Boards (SIBs) that are located in the middle of the chassis behind the fan trays. **SIB 0** through **SIB 2** are located behind the left fan tray, and **SIB 3** through **SIB 5**

are located behind the right fan tray. You must remove the appropriate fan tray to install a SIB. See ["Remove a PTX10016 Fan Tray" on page 246](#).

Ensure you have the following equipment with you before installing a SIB:

- Antistatic bag or antistatic mat
- Electrostatic discharge (ESD) grounding strap

To install a SIB:

1. Place an antistatic bag or an antistatic mat on a flat, stable surface.
2. Wrap and fasten one end of the ESD grounding strap around your bare wrist and connect the other end of the strap to an ESD points on the chassis. There is an ESD point located next to the protective earthing terminal and below **PSU_9** on the rear of the PTX10016 (see [Figure 146 on page 304](#)).

Figure 146: ESD Point on the Rear of the PTX10016

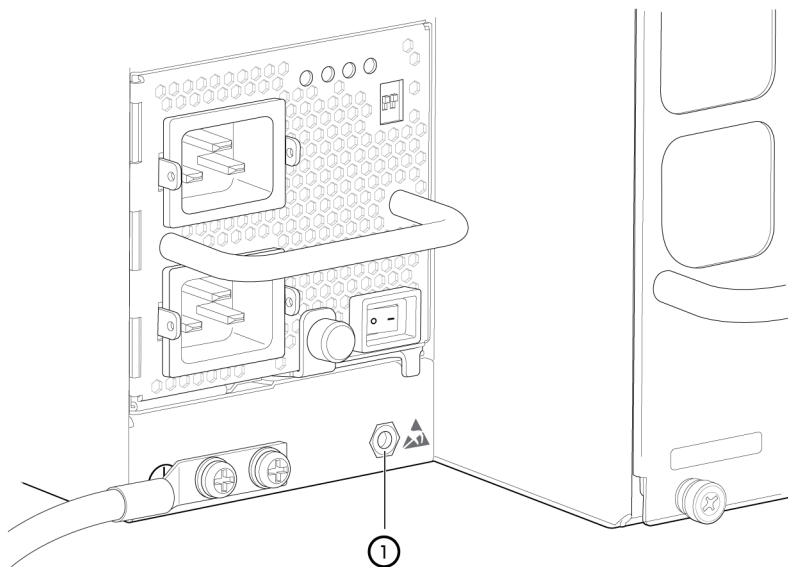

8050729

3. Remove the appropriate fan tray (see ["Remove a PTX10016 Fan Tray" on page 246](#)).
4. Remove the failing SIB (see ["Remove a PTX10016 Switch Interface Board" on page 307](#)).
5. Lift the SIB by the handle with one hand and support the lower edge with the other hand.
6. Holding the SIB vertically, slide the SIB into the open slot until the ejector handles engage and start to close.

7. Grasp the two ejector handles and fold them inward until they latch to seat the SIB (see [Figure 147 on page 305](#)).

Figure 147: Install a PTX10016 SIB

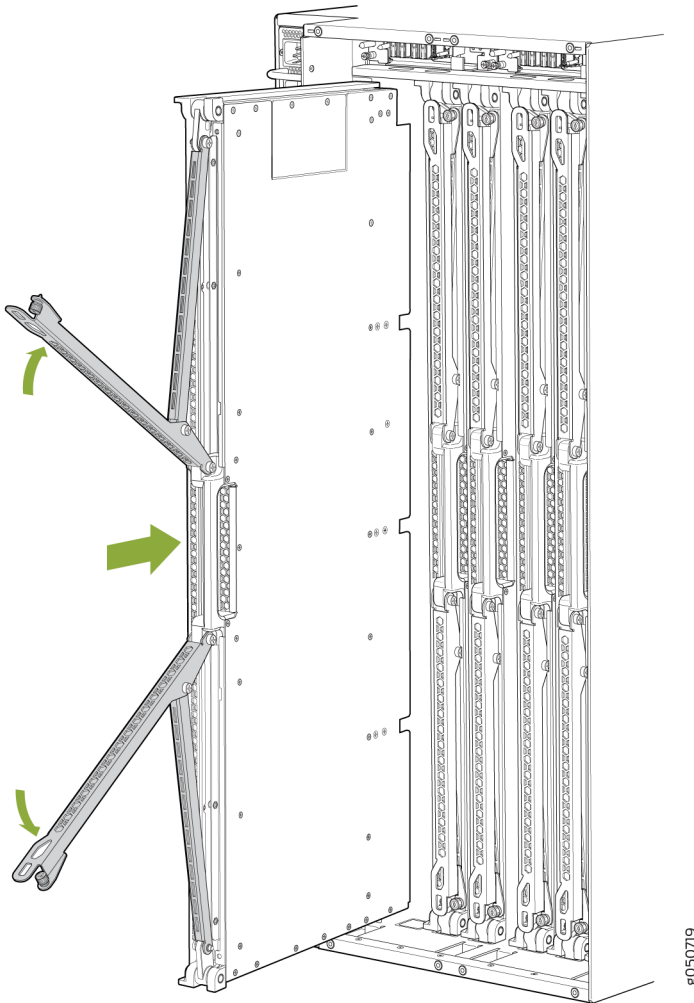

8. Hand-tighten the captive screws.
9. Bring the SIB online using the request `chassis sib slot slot number online` command.

You can check the status of the SIB using the `show chassis fabric sibs` and the `show chassis fabric plane-location` commands. For example:

```
root> show chassis fabric sibs
Fabric management SIB state:
SIB #0 Online
  FASIC #0 (plane 0) Active
```

```

FPC #0
  PFE #0 : OK
  PFE #1 : OK
  PFE #2 : OK
  PFE #3 : OK
  PFE #4 : OK
  PFE #5 : OK
FPC #3
  PFE #0 : OK
  PFE #1 : OK
  PFE #2 : OK
  PFE #3 : OK
  PFE #4 : OK
  PFE #5 : OK
FASIC #1 (plane 1) Active
  FPC #0
    PFE #0 : OK
    PFE #1 : OK
    PFE #2 : OK
    PFE #3 : OK
    PFE #4 : OK
    PFE #5 : OK
  FPC #3
    PFE #0 : OK
    PFE #1 : OK
    PFE #2 : OK
    PFE #3 : OK
    PFE #4 : OK
    PFE #5 : OK
SIB #1 Empty
SIB #2 Empty
SIB #3 Empty
SIB #4 Empty
SIB #5 Empty

root> show chassis fabric plane-location
-----Fabric Plane Locations-----
SIB      Planes
  0       0   1
  1       2   3
  2       4   5
  3       6   7

```

4	8	9
5	10	11

NOTE: If you completely powered off a failing SIB using the `set chassis sib power-off slot slot` command, you must delete the configuration in order to bring the new SIB online. To delete the configuration and bring a replacement SIB online, use the `delete chassis sib power-off slot slot number` command.

Remove a PTX10016 Switch Interface Board

A PTX10016 router has six Switch Interface Boards (SIBs) that are located in the middle of the chassis behind the fan trays. **SIB 0** through **SIB 2** are located behind the left fan tray and **SIB 3** through **SIB 5** are located behind the right fan tray. You must remove the appropriate fan tray to access the failing SIB. See ["Remove a PTX10016 Fan Tray" on page 246](#).

Ensure you have the following equipment with you before replacing a SIB:

- Antistatic bag or antistatic mat
- Electrostatic discharge (ESD) grounding strap

To remove a SIB :

1. Take the SIB offline using the `request chassis sib slot slot number offline` command.

NOTE: If you suspect the SIB is faulty and want to ensure that packets do not flow through the SIB, power off the SIB instead of taking the SIB offline. To power off the SIB, use the `set chassis sib power-off slot slot number` command. Before you bring a new SIB in that slot online, you must delete the old configuration using the `delete chassis sib power-off slot slot number` command.

2. Place an antistatic bag or an antistatic mat on a flat, stable surface.

3. Wrap and fasten one end of the ESD grounding strap around your bare wrist and connect the other end of the strap to an ESD point on the chassis. There is an ESD point located next to the protective earthing terminal and below **PSU_9** on the rear of the PTX10016 (see [Figure 148 on page 308](#)).

Figure 148: ESD Point on the Rear of the PTX10016

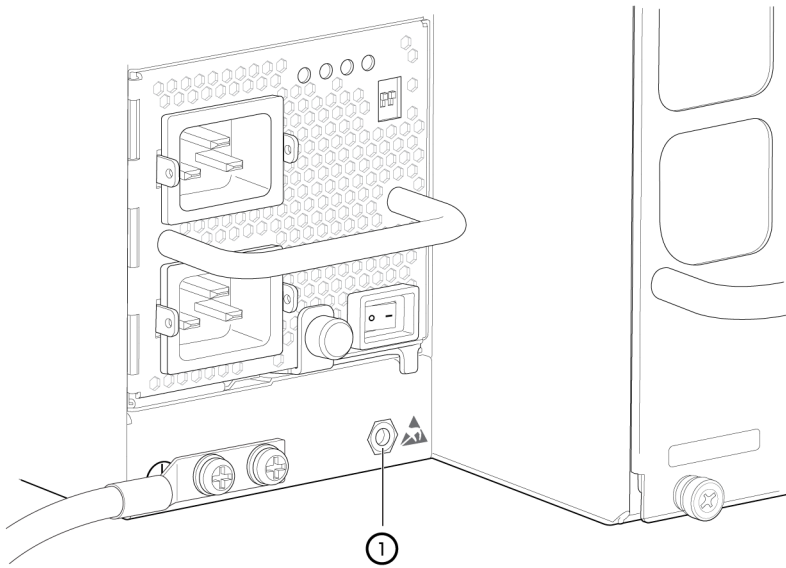

8050729

4. Remove the appropriate fan tray (see ["Remove a PTX10016 Fan Tray" on page 246](#)).
5. Using your fingers, loosen the captive screws at the top and bottom of the SIB.

6. Grasp both ejector handles and spread them apart. The SIB slides about a quarter of the way out of the slot. See [Figure 149](#) on page 309.

Figure 149: Loosen the Captive Screws and Spread the Ejector Handles

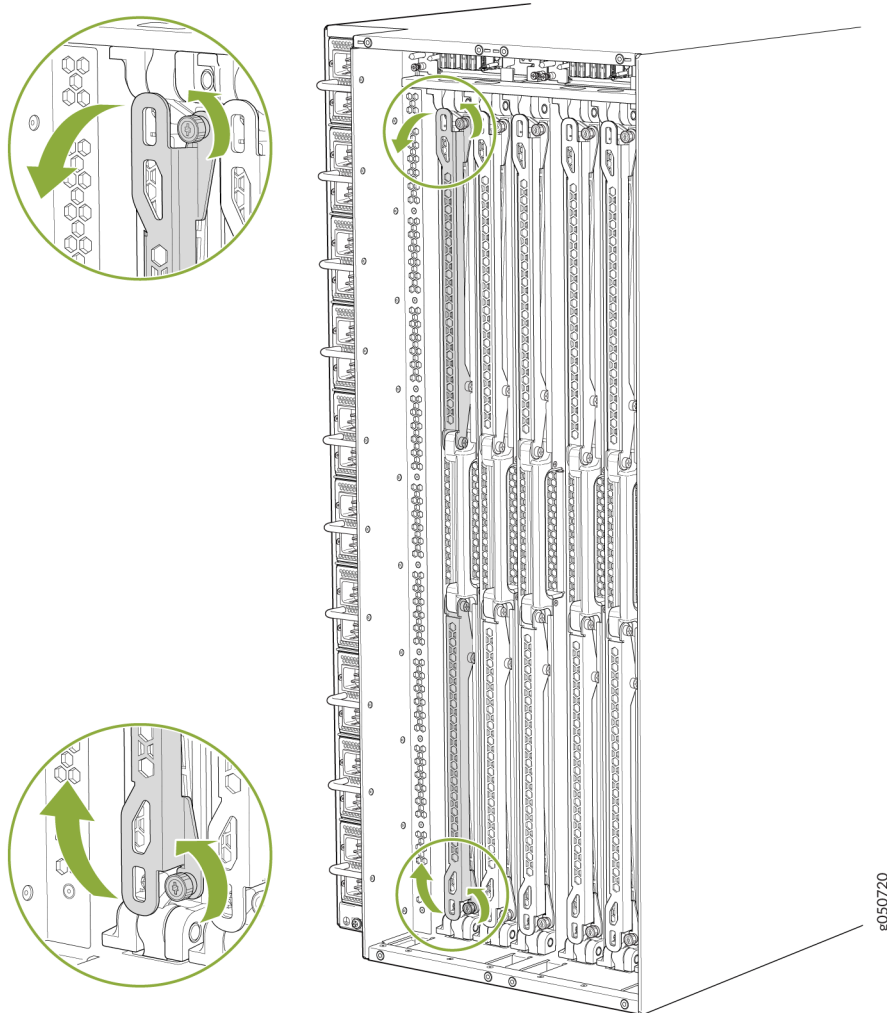

7. Grasp the ejector handle with one hand and place your other hand under the SIB for support as you slide the SIB out of the slot (see [Figure 150 on page 310](#)).

Figure 150: Remove the SIB from a PTX10016 Chassis

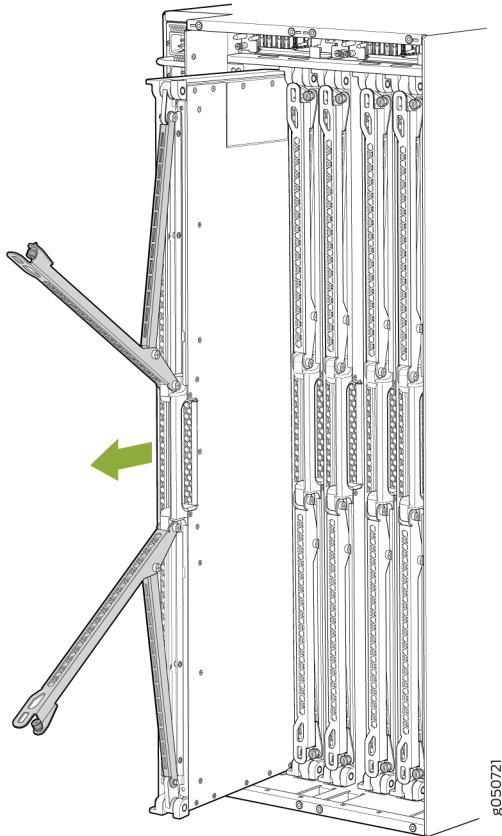

8. Support the SIB as you rotate the SIB 90 degrees and place it on the antistatic mat with the printed circuit board (PCB) facing upward. Be careful not to bump or handle the SIB by the connectors. If you do not have an antistatic mat, have another person help you slide the antistatic bag over the SIB before placing it on a stable surface. See [Figure 151 on page 311](#).



CAUTION: Do not stack hardware components on top of one another after you remove them. Place each component on an antistatic mat resting on a stable, flat surface.

Figure 151: Extracted SIB

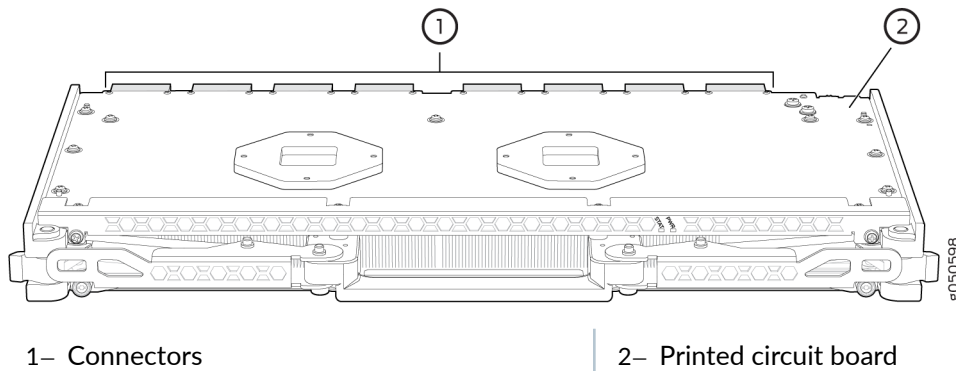

RELATED DOCUMENTATION

[PTX10016 Switch Interface Board Description | 78](#)

Install and Remove PTX10016 Line Card Components

IN THIS SECTION

- [Install a PTX10016 Line Card | 312](#)
- [Remove a PTX10016 Line Card | 315](#)
- [Install the PTX10016 Cable Management System | 318](#)

Line cards on the PTX10016 are field-replaceable units (FRUs) that can be installed in any of the line-card slots on the front of the chassis. The line cards are hot-insertable and hot-removable: you can remove and replace them without powering off the router or disrupting router functions. You can use the following line cards in a PTX100016 router.

- PTX10K-LC1101
- PTX10K-LC1102
- PTX10K-LC1104
- PTX10K-LC1105
- QFX10000-60S-6Q

Install a PTX10016 Line Card

Before you install a line card in the router chassis:

- Ensure that you have taken the necessary precautions to prevent electrostatic discharge (ESD) damage. See ["Prevention of Electrostatic Discharge Damage" on page 388](#).
- Ensure that you know how to handle and store the line card. See ["How to Handle and Store PTX10016 Line Cards, RCBs, and SIBs" on page 300](#).
- Inspect the connector edge of the line card for physical damage. Installing a damaged line card might damage the router.
- Ensure that the router has sufficient power to power the line card while maintaining its $n+1$ power redundancy. To determine whether the router has enough power available for the line card, use the `show chassis power-budget-statistics` command.
- Ensure that you have the following parts and tools available to install a line card in the router:
 - ESD grounding strap
 - Phillips (+) screwdriver, number 2

To install a line card in the router chassis:

1. Wrap and fasten one end of the ESD grounding strap around your bare wrist and connect the other end of the strap to one of the ESD points on the chassis. An ESD point is located above the status LED panel on the front of the router chassis. See [Figure 152 on page 313](#).

Figure 152: ESD Point on the Front of the PTX10016

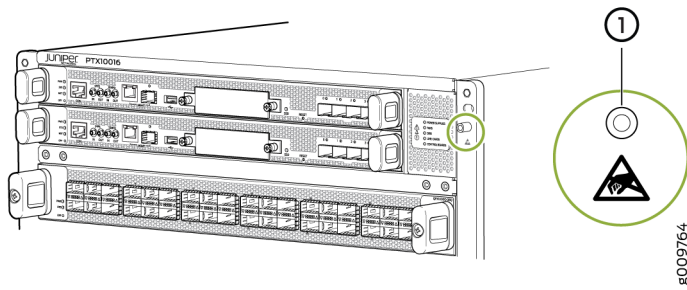

1- ESD point

2. Remove the line-card cover by grasping the handles and pulling straight out to expose the slot for the line card. See [Figure 153 on page 314](#).

Figure 153: Remove the Line-Card Cover

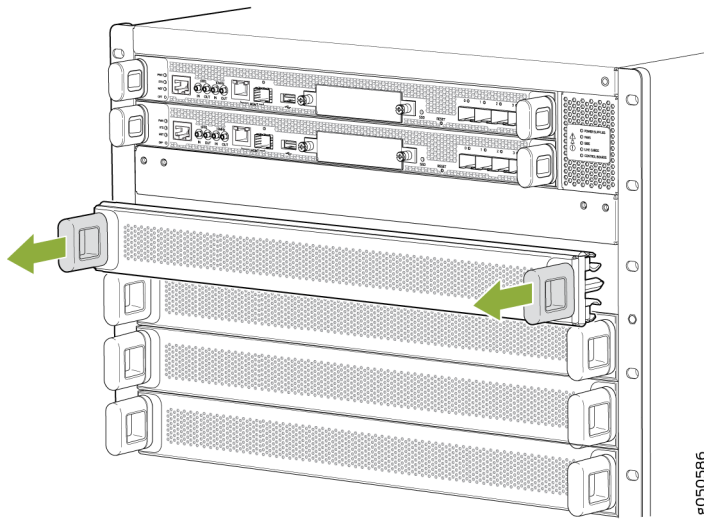
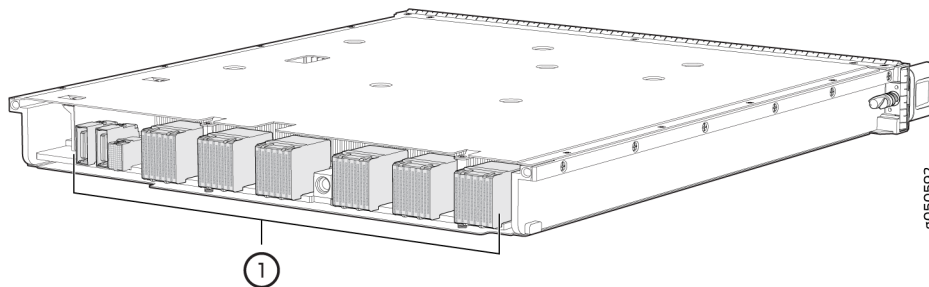

Figure 154: Line Card Connectors



1– Connectors

3. Remove the line card from the antistatic bag and inspect it for any damage before installing it into the chassis.



CAUTION: Do not lift the line card by holding the edge connectors or the handles on the faceplate. Neither the handles nor the edge connectors can support the weight of the line card. Lifting the line card by the handles or edge connectors might bend them,

which would prevent the line cards from being properly seated in the chassis. See [Figure 154 on page 314](#).

4. Grasp and lift the line card by the sides.
5. Slide the line card all the way into the slot until the handle holes align. See [Figure 155 on page 315](#).

Figure 155: Insert the Line Card into the Slot and Rotate the Handles

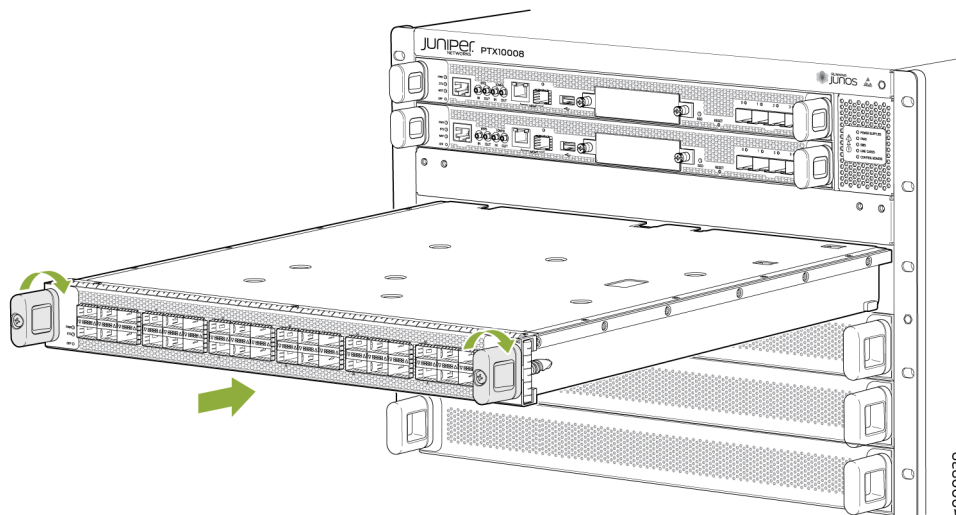

6. Insert the line card into the chassis by rotating the handles simultaneously until the card is fully seated and the handles are vertical.
7. Bring the line card online by using the `request-chassis-fpc slot slot-number online` command.

You can install the optional cable management kit after the card is installed.

Remove a PTX10016 Line Card

If you have the optional line-card cable management system, it is not necessary to remove the cable management system before removing the line card. However, we recommend that you take the line cards offline before removing them.

Before you remove a line card from the router chassis:

- Ensure that you have taken the necessary precautions to prevent electrostatic discharge (ESD) damage. See ["Prevention of Electrostatic Discharge Damage" on page 388](#).
- If there are any optical cables, (including transceivers installed in the line card), remove them before you remove the line card. See ["PTX10016 Transceiver Removal" on page 325](#).

- Ensure that you know how to handle and store the line card. See "[How to Handle and Store PTX10016 Line Cards, RCBs, and SIBs](#)" on page 300.
- Ensure that you have the following parts and tools available to remove a line card from a PTX10016 chassis:
 - ESD grounding strap
 - An antistatic bag or an antistatic mat

NOTE: Placing a line card in an antistatic bag might require a second person to assist with sliding the line card into the bag.

- Replacement line card or a cover for the empty slot

To remove a line card from a PTX10016 router chassis:

1. Place the antistatic bag or antistatic mat on a flat, stable surface.
2. Wrap and fasten one end of the ESD grounding strap around your bare wrist and connect the other end of the strap to an ESD point on the front of the chassis (see [Figure 156 on page 316](#)).

Figure 156: ESD Point on the Front of the PTX10016

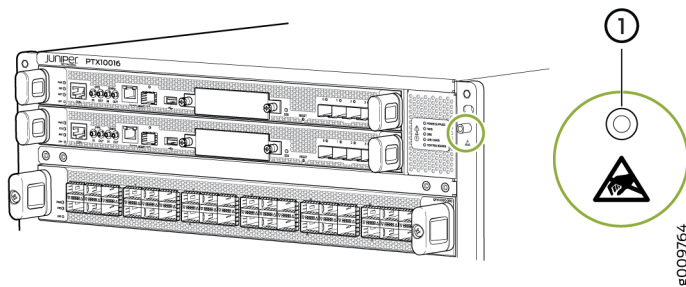

1– ESD point

3. Label the cables connected to each port on the line card so you can reconnect the cables to the correct ports.
4. Take the line card offline by issuing the following CLI command:

```
user@router> request chassis fpc slot slot-number offline
```

5. Unscrew the line card from the chassis by continually turning the handles to the left until the line card is fully unseated. See [Figure 157 on page 317](#).

Figure 157: Remove a PTX10016 Line Card

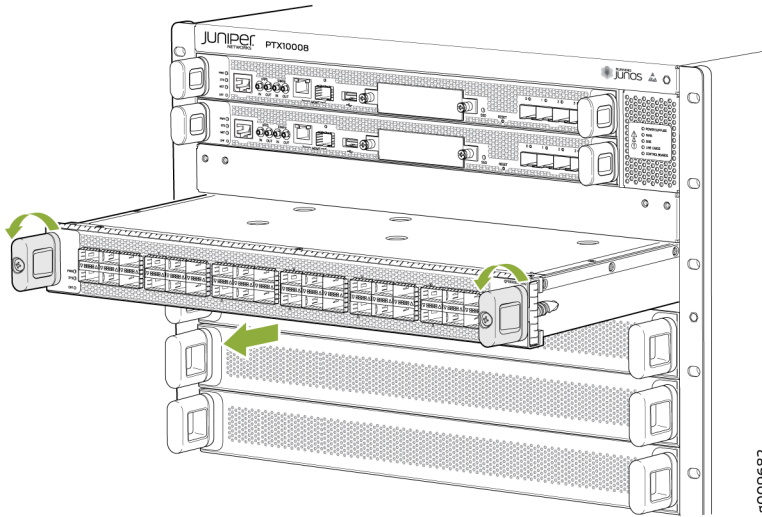

6. Using the handles, slide the line card halfway out of the chassis.



CAUTION: Do not stack line cards on top of one another or on top of any other component. Place each line card separately in the antistatic bag or on the antistatic mat placed on a flat, stable surface.



CAUTION: Each PTX10016 line card weighs between 20.9 lb (9.5 kg) and 27.3 lb (12.4 kg). Be prepared to support the full weight as you slide the line card out of the chassis.

7. Grasp both sides of the line card at midpoint and remove the line card from the chassis. Either have someone assist you in putting the line card into the antistatic bag or rest the card on the antistatic mat. Take care not to bump or store the line cards on the connectors. See [Figure 158 on page 318](#).

Figure 158: PTX100016 Line Card Connectors

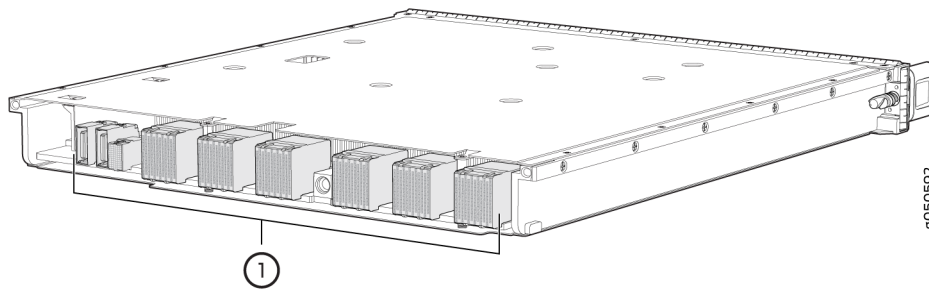

1– Connectors

8. If you are not installing a line card in the emptied line-card slot within a short time, install a cover over the slot. Do this to protect the interior of the chassis from dust or other foreign substances and to ensure that the airflow inside the chassis is not disrupted.

Install the PTX10016 Cable Management System

The PTX10016 cable management system is an optional, orderable kit (JLC-CBL-MGMT-KIT) that you can use to organize and protect optical cabling attached to the line cards. After a line card is installed, you can still remove the line card without needing to remove the cable management system.

Ensure that you have the following parts and tools available to install the PTX10016 cable management system on a line card:

- Phillips (+) screwdriver, number 2

To install the cable management system (see [Figure 159 on page 319](#)):

1. Open the shipping carton for cable management system and check that you have:
 - Two handle extensions

- One cable tray

Figure 159: Cable Management System Components

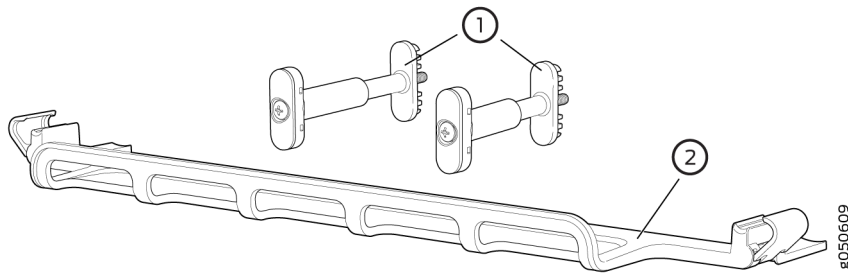

1– Handle extensions

2– Cable tray

2. Use the Phillips screwdriver to loosen and remove the screws on the two line card handles (see [Figure 160 on page 319](#)).

Figure 160: Remove the Handle Screws

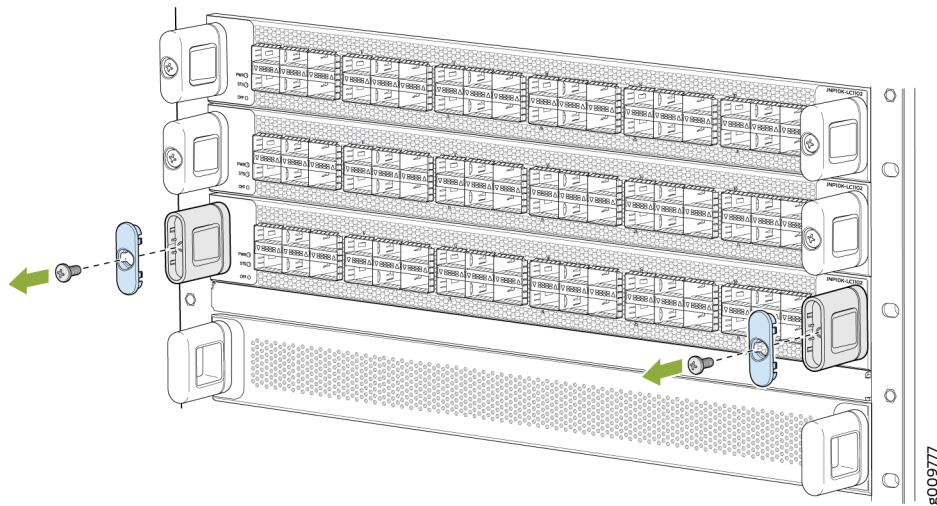

3. Replace the blue cap on the line-card handle with the two handle extensions (see [Figure 161](#) on page 320).

Figure 161: Attach the Handle Extensions

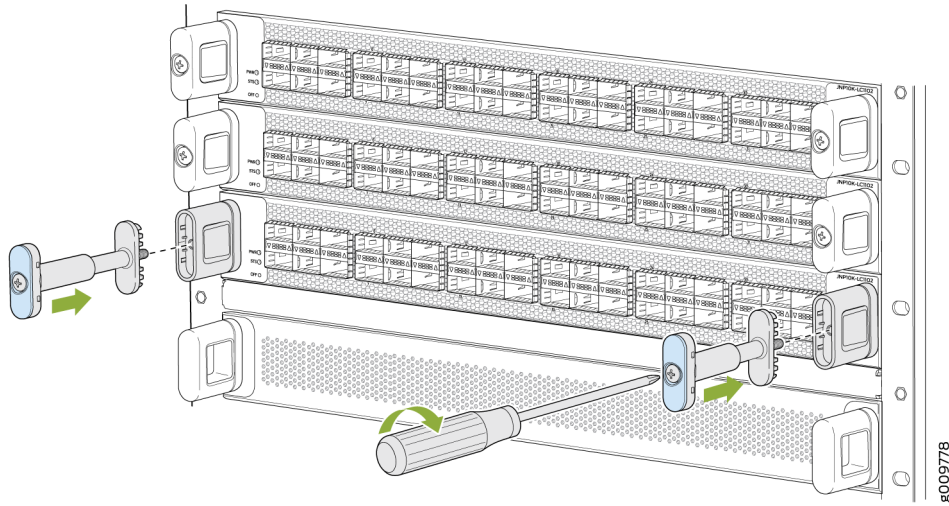

4. Tighten the screws into the handle extensions.
5. Snap open the blue clips on the ends of the cable tray with your hands.
6. Place the cable tray across the front of the line card so that the two ends of the cable tray are under the handle extensions.

7. Snap to close the blue clips of the cable tray around the handle extensions (see [Figure 162 on page 321](#)).

Figure 162: Add the Cable Tray

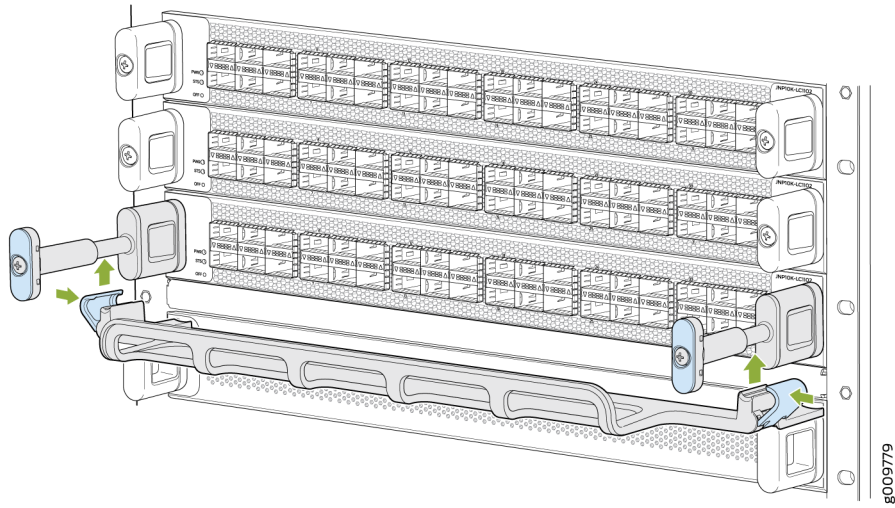

8. Drape and tie the optical cables to the side (see [Figure 163 on page 322](#)). Another option is to drape some of the cables under the handle extension and some cables over the handle extension.

Figure 163: Completed Cable Management System

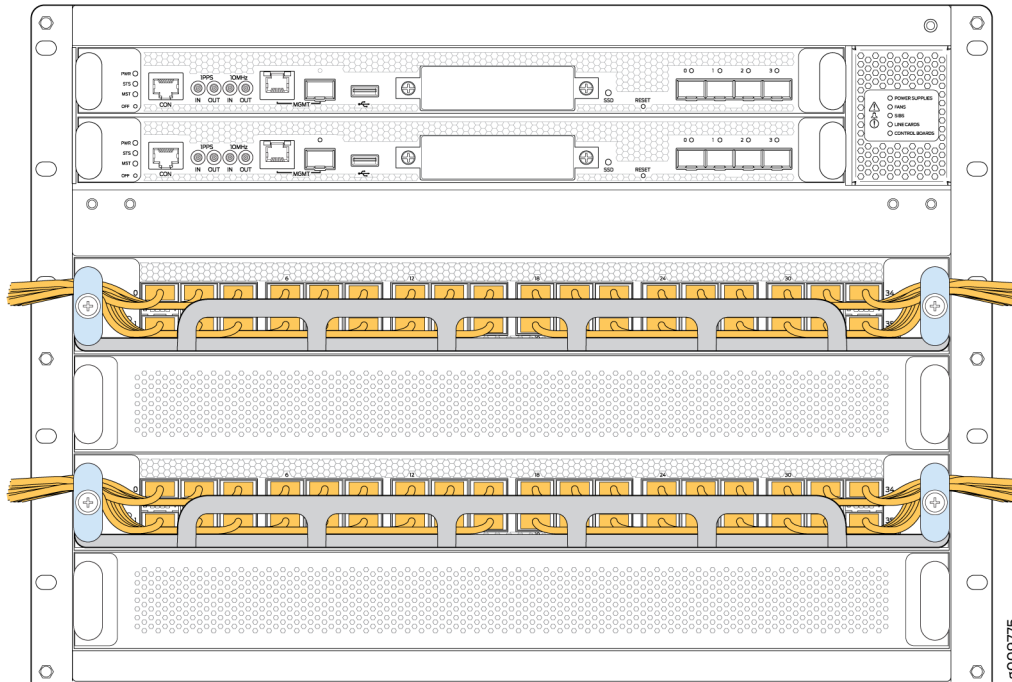

RELATED DOCUMENTATION

[PTX10016 Optional Equipment | 28](#)

[How to Handle and Store PTX10016 Line Cards, RCBs, and SIBs | 300](#)

PTX10016 Transceiver and Fiber-Optic Cable Installation and Removal

IN THIS SECTION

- [PTX10016 Transceiver Installation | 323](#)
- [PTX10016 Transceiver Removal | 325](#)
- [How to Connect a Fiber-Optic Cable from a Transceiver on a PTX10016 Router | 327](#)
- [How to Disconnect a Fiber-Optic Cable from a Transceiver on a PTX10016 Router | 328](#)
- [How to Maintain Fiber-Optic Cable for a PTX10016 Router | 329](#)

The transceivers for the PTX10016 router are hot-removable and hot-insertable field-replaceable units (FRUs). You can remove and replace them without powering off the device or disrupting device functions.

To understand how to install or remove a transceiver in a PTX10016 router, read the following sections:

PTX10016 Transceiver Installation

Before you begin installing a transceiver in a PTX10016 line card or RCB, ensure that you have taken the necessary precautions for safe handling of lasers (see "[Laser and LED Safety Guidelines and Warnings](#)" on page 377).

Ensure that you have a rubber safety cap available to cover the transceiver.

To install a transceiver in a PTX10016 line card or RCB:



CAUTION: To avoid damaging the transceiver by electrostatic discharge (ESD), do not touch the connector pins at the end of the transceiver.

1. Remove the transceiver from its bag.
2. Check to see whether the transceiver is covered by a rubber safety cap. If it is not, cover the transceiver with a rubber safety cap.



LASER WARNING: Do not leave a fiber-optic transceiver uncovered except when inserting or removing a cable. The rubber safety cap keeps the port clean and prevents accidental exposure to laser light.

3. If the port in which you want to install the transceiver is covered with a dust cover, remove the dust cover and save it in case you need to cover the port later.
4. Using both hands, carefully place the transceiver in the empty port. The connectors must face the device chassis.



CAUTION: Before you slide the transceiver into the port, ensure that the transceiver is aligned correctly. Misalignment might cause the pins to bend, making the transceiver unusable. On PTX10016 line cards, the ports are designed belly-to-belly, which requires you to turn the transceiver over on the bottom port row. See [Figure 164 on page 325](#) and [Figure 165 on page 325](#).

5. Slide the transceiver in gently until it is fully seated.
6. Remove the rubber safety cap when you are ready to connect the cable to the transceiver.

LASER WARNING: Do not look directly into a fiber-optic transceiver or into the ends of fiber-optic cables. Fiber-optic transceivers and fiber-optic cables connected to transceivers emit laser light that can damage your eyes.

Figure 164: Install an SFP Transceiver

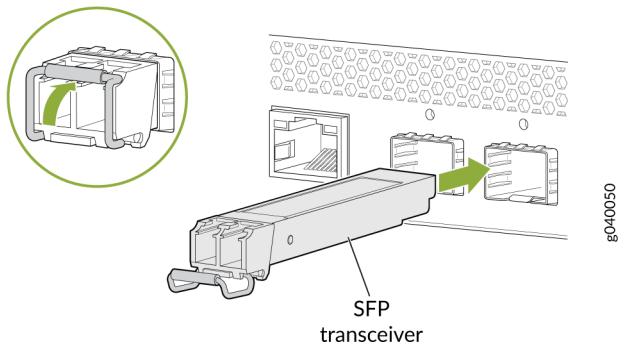
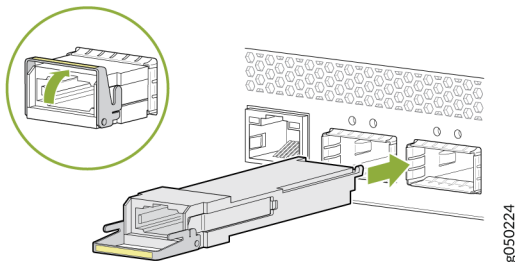

Figure 165: Install a QSFP+, QSFP28, and QSFP56-DD Transceivers



PTX10016 Transceiver Removal

Before remove a transceiver from a PTX10016 line card or RCB, ensure that you have taken the necessary precautions for safe handling of lasers (see ["Laser and LED Safety Guidelines and Warnings" on page 377](#)).

Ensure that you have the following parts and tools available:

- Antistatic bag or an antistatic mat

- Rubber safety caps to cover the transceiver and fiber-optic cable connector
- Dust cover to cover the port

To remove a transceiver from a PTX10016 line card or RCB:

1. Place the antistatic bag or antistatic mat on a flat, stable surface.
2. Wrap and fasten one end of the ESD wrist strap around your bare wrist, and connect the other end of the strap to the ESD point on the router chassis.
3. Label the cable connected to the transceiver so that you can reconnect it correctly.



LASER WARNING: Do not look directly into a fiber-optic transceiver or into the ends of fiber-optic cables. Fiber-optic transceivers and fiber-optic cables connected to transceivers emit laser light that can damage your eyes.



LASER WARNING: Do not leave a fiber-optic transceiver uncovered except when inserting or removing a cable. The rubber safety cap keeps the port clean and prevents accidental exposure to laser light.



CAUTION: Do not bend fiber-optic cables beyond their minimum bend radius. Bending the cables beyond their minimum bend radius can damage the cables and cause problems that are difficult to diagnose.

4. Remove the cable connected to the transceiver (see ["How to Disconnect a Fiber-Optic Cable from a Transceiver on a PTX10016 Router" on page 328](#)). Cover the transceiver and the end of each fiber-optic cable connector with a rubber safety cap immediately after disconnecting the fiber-optic cables.
5. Using your fingers, pull the ejector lever away from the transceiver to unlock the transceiver.



CAUTION: Before removing the transceiver, make sure you open the ejector lever completely until you hear it click. This prevents damage to the transceiver.

6. Grasp the transceiver ejector lever and gently slide the transceiver approximately 0.5 in. (1.3 cm) straight out of the port.



CAUTION: To prevent electrostatic discharge (ESD) damage to the transceiver, do not touch the connector pins at the end of the transceiver.

7. Using your fingers, grasp the body of the transceiver and pull it straight out of the port.
8. Place the transceiver in the antistatic bag or on the antistatic mat placed on a flat, stable surface.
9. Place the dust cover over the empty port.

How to Connect a Fiber-Optic Cable from a Transceiver on a PTX10016 Router

Before you connect a fiber-optic cable to an optical transceiver installed in the PTX10016 router, ensure that you have taken the necessary precautions for safe handling of lasers (see "[Laser and LED Safety Guidelines and Warnings](#)" on page 377).

To connect a fiber-optic cable to an optical transceiver installed in the PTX10016 router:



LASER WARNING: Do not look directly into a fiber-optic transceiver or into the ends of fiber-optic cables. Fiber-optic transceivers and fiber-optic cables connected to transceivers emit laser light that can damage your eyes.



LASER WARNING: Do not stare into the laser beam or view it directly with optical instruments even if the interface has been disabled.

1. If the fiber-optic cable connector is covered by a rubber safety cap, remove the cap. Save the cap.
2. If the optical transceiver is covered by a rubber safety cap, remove the cap. Save the cap.
3. Insert the cable connector into the optical transceiver.
4. Secure the cables so that they are not supporting their own weight. Place excess cable out of the way in a neatly coiled loop. Placing fasteners on a loop helps cables maintain their shape.



CAUTION: Do not bend fiber-optic cables beyond their minimum bend radius. Bending the cables beyond their minimum bend radius can damage the cables and cause problems that are difficult to diagnose.



CAUTION: Do not let fiber-optic cables hang free from the connector. Do not allow fastened loops of cables to dangle, which stresses the cables at the fastening point.

How to Disconnect a Fiber-Optic Cable from a Transceiver on a PTX10016 Router

Before you disconnect a fiber-optic cable from an optical transceiver installed in a PTX10016 router, ensure that you have taken the necessary precautions for safe handling of lasers (see "[Laser and LED Safety Guidelines and Warnings](#)" on page 377).

Ensure that you have the following parts and tools available:

- Rubber safety cap to cover the transceiver
- Rubber safety cap to cover the fiber-optic cable connector

To disconnect a fiber-optic cable from an optical transceiver installed in the PTX10016 router:

1. (Recommended) Disable the port in which the transceiver is installed by including the disable statement at the [edit interfaces] hierarchy level for the specific interface.



LASER WARNING: Do not look directly into a fiber-optic transceiver or into the ends of fiber-optic cables. Fiber-optic transceivers and fiber-optic cables connected to transceivers emit laser light that can damage your eyes.



LASER WARNING: Do not stare into the laser beam or view it directly with optical instruments even if the interface has been disabled.

2. Carefully unplug the fiber-optic cable connector from the transceiver.
3. Cover the transceiver with a rubber safety cap.



LASER WARNING: Do not leave a fiber-optic transceiver uncovered except when inserting or removing a cable. The rubber safety cap keeps the port clean and prevents accidental exposure to laser light.

4. Cover the fiber-optic cable connector with the rubber safety cap.

How to Maintain Fiber-Optic Cable for a PTX10016 Router

To maintain fiber-optic cables in a PTX10016 router:

- When you unplug a fiber-optic cable from a transceiver, place rubber safety caps over the transceiver and on the end of the cable.
- Anchor fiber-optic cable to avoid stress on the connectors. When attaching a fiber-optic cable to a transceiver, be sure to secure the fiber-optic cable so that it does not support its own weight as it hangs to the floor. Never let a fiber-optic cable hang free from the connector.
- Do not bend fiber-optic cables beyond their minimum bend radius. Bending the cables beyond their minimum bend radius can damage the cables and cause problems that are difficult to diagnose.
- Frequent plugging and unplugging of fiber-optic cables in and out of optical instruments can damage the instruments, which are expensive to repair. Attach a short fiber extension to the optical equipment. Any wear and tear due to frequent plugging and unplugging is then absorbed by the short fiber extension, which is easier and less expensive to replace than the instruments.
- Keep fiber-optic cable connections clean. Microdeposits of oil and dust in the canal of the transceiver or cable connector can cause loss of light, reduction in signal power, and possibly intermittent problems with the optical connection.

To clean the transceiver canal, use an appropriate fiber-cleaning device such as RIFOCS Fiber Optic Adaptor Cleaning Wands (part number 946). Follow the directions in the cleaning kit you use.

After cleaning the transceiver, make sure that the connector tip of the fiber-optic cable is clean. Use only an approved alcohol-free fiber-optic cable cleaning kit such as the Cletop-S® Fiber Cleaner. Follow the directions in the cleaning kit you use.

RELATED DOCUMENTATION

[PTX10016 Transceiver and Cable Specifications](#) | 188

Remove the PTX10016 Router from the Rack

IN THIS SECTION

- [Power Off a PTX10016 Router | 330](#)
- [Remove the PTX10016 from a Four-Post Rack Using a Mechanical Lift | 333](#)

To power off and remove a PTX10016 router, read the following sections:

Power Off a PTX10016 Router

Before you power off a PTX10016 router:

- Ensure that you have taken the necessary precautions to prevent electrostatic discharge (ESD) damage. See ["Prevention of Electrostatic Discharge Damage" on page 388](#).
- Ensure that you do not need to forward traffic through the router.
- Ensure that you have the following parts and tools available to power off the router:
 - An ESD grounding strap
 - An external management device such as a PC
 - An RJ-45 to DB-9 rollover cable to connect the external management device to the console port on one of the RCBs

To power off a PTX10016 router:

1. Connect to the router using one of the following methods:
 - Connect a management device to the console (**CON**) port on an RCB by following the instructions in ["Connect a PTX10016 Router to a Management Console" on page 231](#).
 - Connect a management device to one of the two management (**MGMT**) ports on an RCB by following the instructions in ["Connect a PTX10016 Router to a Network for Out-of-Band Management" on page 230](#).
2. Shut down Junos OS from the external management device. On standard Junos OS systems, you can use the request `vmhost halt operational mode` CLI command. On Junos OS Evolved systems use the

request system shutdown power-off operational mode CLI command. These command shuts down the router gracefully and preserves system state information. A message appears on the console, confirming that the operating system has halted.

You see the following output (or something similar, depending on the hardware being shut down) after entering the command:

```
Shutdown NOW!
System going down IMMEDIATELY

Terminated
Poweroff for hypervisor to respawn
Oct 25 10:35:05 init: event-processing (PID 1114) exited with status=1
Oct 25 10:35:05 init: packet-forwarding-engine (PID 1424) exited with status=8
.
Waiting (max 60 seconds) for system process `vnlru_mem' to stop...done
Waiting (max 60 seconds) for system process `vnlru' to stop...done
Waiting (max 60 seconds) for system process `bufdaemon' to stop...done
Waiting (max 60 seconds) for system process `syncer' to stop...
Syncing disks, vnodes remaining...0 0 0 0 done

syncing disks... All buffers synced.
Uptime: 11h0m30s
Normal shutdown (no dump device defined)
unloading fpga driver
unloading fx-scpld
Powering system off using ACPI
kvm: 28646: cpu0 disabled perfctr wrmsr: 0xc1 data 0xabcd
pci-stub 0000:01:00.2: transaction is not cleared; proceeding with reset anyway
pci-stub 0000:01:00.1: transaction is not cleared; proceeding with reset anyway
hub 1-1:1.0: over-current change on port 1
Stopping crond: [ OK ]
Stopping libvirtd daemon: [ OK ]
Shutting down ntpd: [ OK ]
Shutting down system logger: [ OK ]
Shutting down sntpc: [ OK ]
Stopping sshd: [ OK ]
Stopping vhostd: [ OK ]
Stopping watchdog: [ OK ]
Stopping xinetd: [ OK ]
Sending all processes the TERM signal... [ OK ]
Sending all processes the KILL signal... [ OK ]
```

```

Saving random seed: [ OK ]
Syncing hardware clock to system time [ OK ]
Turning off swap: [ OK ]
Unmounting file systems: [ OK ]
init: Re-executing /sbin/init
Halting system...
System halted.

```



CAUTION: The final output of any version of the request `vmhost halt` command is the message “The operating system has halted.” Wait at least 60 seconds after first seeing this message before following the instructions in Step “4” on page 332 and Step “5” on page 332 to power off the router.

3. Wrap and fasten one end of the ESD grounding strap around your bare wrist and connect the other end of the strap to one of the ESD points on the chassis.
4. Disconnect power to the router by performing one of the following tasks:
 - AC power supply—Set the enable switch to the off (O) position and gently pull out the coupler for the power cord from the faceplate.
 - DC power supply—Switch the circuit breaker on the panel board that services the DC circuit to the off position.
5. Remove the power source cable from the power supply faceplate:
 - AC power supply—Remove the power cord from the power supply faceplate by detaching the power cord retainer and gently pulling out the plug end of the power cord connected to the power supply faceplate.
 - DC power supply—Loosen the thumbscrews securing the DC power connector on the power source cables. Remove the power source cables from the power supply.
6. Remove any remaining cables and optics before removing it from the rack.

SEE ALSO

[Connect AC Power to the PTX10016 Router | 227](#)

[Connect DC Power to a PTX10016 Router | 228](#)

Remove the PTX10016 from a Four-Post Rack Using a Mechanical Lift

Before you remove the router using a lift:

- Ensure that the rack is stable and secured to the building.
- Ensure there is enough space to place the removed router in its new location and along the path to the new location. See ["PTX10016 Clearance Requirements for Airflow and Hardware Maintenance" on page 155](#).
- Review ["General Safety Guidelines and Warnings" on page 363](#).
- Review the chassis lifting guidelines described in ["PTX10016 Chassis Lifting Guidelines" on page 369](#).
- Ensure that the router is safely powered off (see ["Power Off a PTX10016 Router" on page 330](#) and ["Connect AC Power to the PTX10016 Router" on page 227](#)).



CAUTION: When removing more than one router chassis from a rack, remove the routers in order from top to bottom.

- Ensure that you have the following parts and tools available to remove the router:
 - A mechanical lift rated for 1000 lb (453.6 kg)
 - A Phillips (+) screwdriver, number 2 or number 3, depending on the size of your mounting screws

Because of the router's size and weight, we only recommend that you use a mechanical lift to install the PTX10016.

To remove the router using a mechanical lift (see [Figure 166 on page 334](#)):

1. Use the appropriate Phillips (+) screwdriver to remove the 12 mounting screws that attach the chassis flange to the rack.
2. Move the lift to the rack and position it so that its platform is centered about 0.5 in. (1.27 cm) below the bottom of the router chassis and as close to it as possible.
3. Carefully slide the router from the adjustable mounting rails and blades attached to the rack onto the lift.
4. Move the lift away from the rack and lower the platform on the lift.

5. Use the lift to transport the router to its new location.

Figure 166: Move the PTX10016 Using a Mechanical Lift

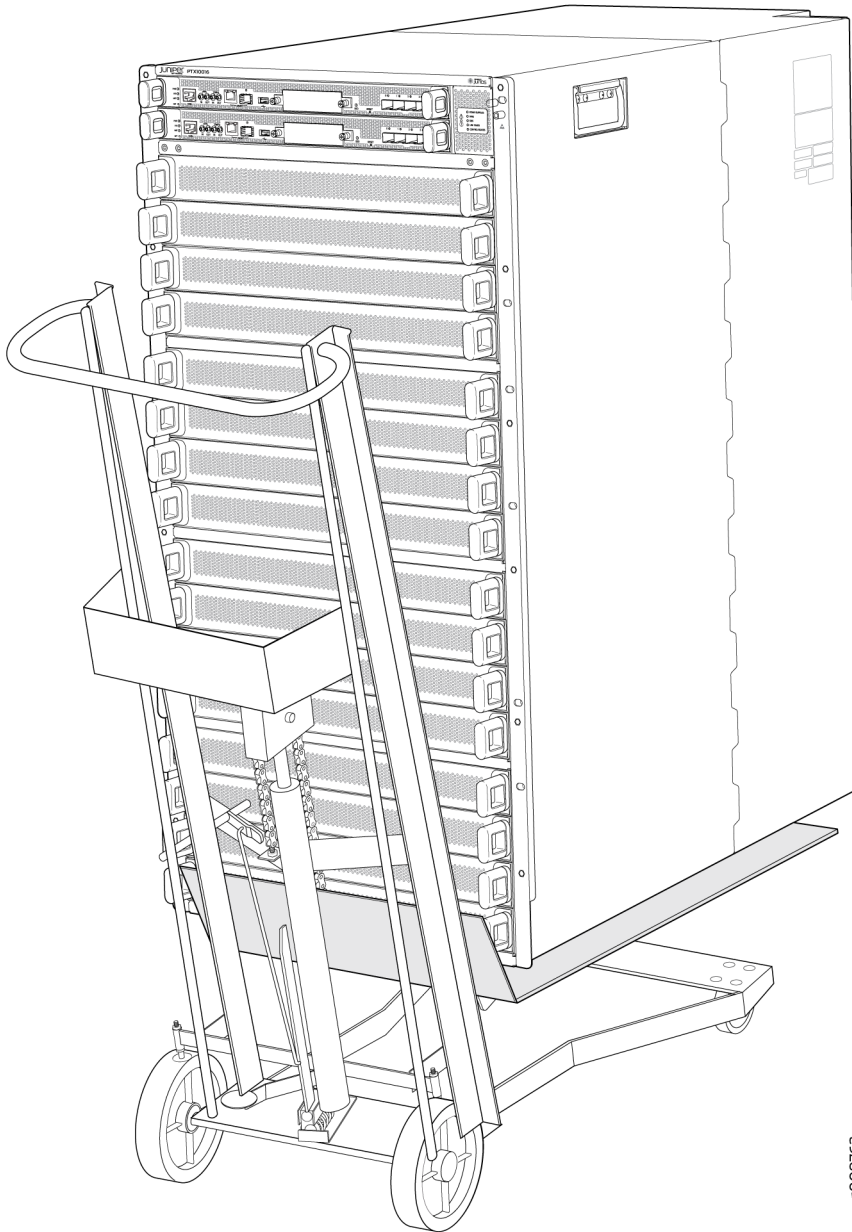

g009763

RELATED DOCUMENTATION

[Connect AC Power to the PTX10016 Router](#) | 227

| [Connect DC Power to a PTX10016 Router](#) | 228

5

CHAPTER

Troubleshooting Hardware

[Alarm Messages](#) | 337

Alarm Messages

IN THIS SECTION

- [Alarms - A Glossary | 337](#)
- [Interface Alarm Messages | 338](#)

The following sections contain PTX10008 and PTX10016 alarm information.

Alarms - A Glossary

The PTX10008 and PTX10016 routers support different alarm types and severity levels. [Table 81 on page 337](#) provides a list of alarm terms and definitions that may help you in monitoring the device.

Table 81: Alarm Terms and Definitions

Term	Definition
Alarm	Signal alerting you to conditions that might prevent normal operation. On the device, alarm indicators might include the LCD panel and LEDs on the device. The LCD panel (if present on the device) displays the chassis alarm message count. Blinking amber LEDs indicate yellow alarm conditions for chassis components.
Alarm condition	Failure event that triggers an alarm.

Table 81: Alarm Terms and Definitions (*Continued*)

Term	Definition
Alarm severity levels	<p>Seriousness of the alarm. The level of severity can be either major (red) or minor (yellow).</p> <ul style="list-style-type: none"> • Major (red)—Indicates a critical situation on the device that has resulted from one of the following conditions. A red alarm condition requires immediate action. <ul style="list-style-type: none"> • One or more hardware components have failed. • One or more hardware components have exceeded temperature thresholds. • An alarm condition configured on an interface has triggered a critical warning. • Minor (yellow or amber)—Indicates a noncritical condition on the device that, if left unchecked, might cause an interruption in service or a degradation in performance. A yellow alarm condition requires monitoring or maintenance. For example, a missing rescue configuration generates a yellow system alarm.
Alarm types	<p>Alarms include the following types:</p> <ul style="list-style-type: none"> • Chassis alarm—Predefined alarm triggered by a physical condition on the device such as a power supply failure or excessive component temperature. • Interface alarm—Alarm you configure to alert you when an interface link is down. Applies to ethernet, fibre-channel, and management-ethernet interfaces. You can configure a red (major) or yellow (minor) alarm for the link-down condition, or have the condition ignored. • System alarm—Predefined alarm that might be triggered by a missing rescue configuration, failure to install a license for a licensed software feature, or high disk usage.

Interface Alarm Messages

Interface alarms are alarms that you configure to alert you when an interface is down.

To configure an interface link-down condition to trigger a red or yellow alarm, or to configure the link-down condition to be ignored, use the *alarm* statement at the [edit chassis] hierarchy level. You can specify the ethernet, fibre-channel, or management-ethernet interface type.

By default, major alarms are configured for interface link-down conditions on the control plane and management network interfaces. The link-down alarms indicate that connectivity to the control plane network is down. You can configure these alarms to be ignored using the *alarm* statement at the [edit chassis] hierarchy level.

RELATED DOCUMENTATION

show chassis alarms

show system alarms



CHAPTER

Contacting Customer Support and Returning the Chassis or Components

[Contact Customer Support | 341](#)

[Return Procedures for the PTX10016 Chassis and Components | 342](#)

Contact Customer Support

You can contact Juniper Networks Technical Assistance Center (JTAC) 24 hours a day, 7 days a week in one of the following ways:

- On the Web, using the Service Request Manager link at:

<https://support.juniper.net/support/>

- By telephone:
 - From the US and Canada: 1-888-314-JTAC
 - From all other locations: 1-408-745-9500

NOTE: If contacting JTAC by telephone, enter your 12-digit service request number followed by the pound (#) key if this is an existing case, or press the star (*) key to be routed to the next available support engineer.

When requesting support from JTAC by telephone, be prepared to provide the following information:

- Your existing service request number, if you have one
- Details of the failure or problem
- Type of activity being performed on the device when the problem occurred
- Configuration data displayed by one or more `show` commands
- Your name, organization name, telephone number, fax number, and shipping address

The support representative validates your request and issues an RMA number for return of the component.

Return Procedures for the PTX10016 Chassis and Components

IN THIS SECTION

- [Return a PTX10016 Router or Component for Repair or Replacement | 342](#)
- [Locate the Serial Number on a PTX10016 Router or Component | 343](#)
- [Locate the Serial Number ID Labels on PTX10016 Power Supplies | 347](#)
- [Locate the Serial Number ID Labels on PTX10016 Fan Trays and Fan Tray Controllers | 350](#)
- [Locate the Serial Number ID Labels on PTX10016 Routing and Control Boards | 352](#)
- [Locate the Serial Number ID Labels on a PTX10016 Line Card | 353](#)
- [Locate the Serial Number ID Labels on a PTX10016 Switch Interface Board \(SIB\) | 353](#)
- [Locate the Serial Number ID Label on a PTX10016 SATA SSD | 354](#)
- [Contact Customer Support to Obtain a Return Materials Authorization for a PTX10016 Router or Component | 354](#)
- [How to Pack a PTX10016 or Component for Shipping | 355](#)

To return a PTX10016 router or component, read the following sections:

Return a PTX10016 Router or Component for Repair or Replacement

If you need to return a PTX10016 router, or a component to Juniper Networks for repair or replacement:

1. Determine the serial number of the component. For instructions, see "[Locate the Serial Number on a PTX10016 Router or Component](#)" on page 343.
2. Obtain a Return Materials Authorization (RMA) number from the Juniper Technical Assistance Center (JTAC), as described in "[Contact Customer Support to Obtain a Return Materials Authorization for a PTX10016 Router or Component](#)" on page 354.

NOTE: Do not return any component to Juniper Networks unless you have first obtained an RMA number. Juniper Networks reserves the right to refuse shipments that do not have an RMA. Refused shipments are returned to the customer through collect freight.

3. Pack the router or component for shipping, as described in "[How to Pack a PTX10016 or Component for Shipping](#)" on page 355.

For more information about return and repair policies, see the customer support page at <https://www.juniper.net/support/guidelines.html>.

Locate the Serial Number on a PTX10016 Router or Component

IN THIS SECTION

- [List the PTX10016 Chassis and Component Details Using the CLI | 344](#)
- [Locate the Chassis Serial Number on a PTX10016 | 346](#)

If you are returning a router or component to Juniper Networks for repair or replacement, you must locate the serial number of the router or component. You must provide the serial number to the Juniper Networks Technical Assistance Center (JTAC) when you contact them to obtain a Return Materials Authorization (RMA). See "[Contact Customer Support to Obtain a Return Materials Authorization for a PTX10016 Router or Component](#)" on page 354.

If the router is operational and you can access the command-line interface (CLI), you can list serial numbers for the router and for some components with a CLI command. If you do not have access to the CLI or if the serial number for the component does not appear in the command output, you can locate the serial number ID label on the router or component.

NOTE: If you want to find the serial number ID label on a component, you need to remove the component from the router chassis, for which you must have the required parts and tools available.

List the PTX10016 Chassis and Component Details Using the CLI

To list the PTX10016 chassis and the components and their serial numbers, use the `show chassis hardware clei-models` CLI operational mode command. See the following examples for different types of configurations and the related output.

show chassis hardware clei-models (PTX10016 Routers)

```

user@host> show chassis hardware clei-models
Hardware inventory:
Item          Version  Part number  CLEI code      FRU model number
Midplane      REV 24   750-077138  CMMUN00ARA     JNP10016
CB 0          REV 04   711-065897  PROTOXCLEI     PROTO-ASSEMBLY
CB 1          REV 05   711-065897  PROTOXCLEI     PROTO-ASSEMBLY
FPC 2
  PIC 0              BUILTIN
FPC 4          REV 35   750-071976  CMUIANABAA     JNP10K-LC1101
  PIC 0              BUILTIN
FPC 5          REV 13   750-068822  CMUIAM9BAC     QFX10000-36Q
  PIC 0              BUILTIN
FPC 6          REV 41   750-071976  CMUIANABAB     JNP10K-LC1101
  PIC 0              BUILTIN
FPC 7          REV 35   750-071976  CMUIANABAA     JNP10K-LC1101
  PIC 0              BUILTIN
FPC 8          REV 35   750-071976  CMUIANABAA     JNP10K-LC1101
  PIC 0              BUILTIN
FPC 9          REV 41   750-071976  CMUIANABAB     JNP10K-LC1101
  PIC 0              BUILTIN
FPC 10        REV 35   750-071976  CMUIANABAA     JNP10K-LC1101
  PIC 0              BUILTIN
FPC 11        REV 35   750-071976  CMUIANABAA     JNP10K-LC1101
  PIC 0              BUILTIN
FPC 13        REV 41   750-071976  CMUIANABAB     JNP10K-LC1101
  PIC 0              BUILTIN
FPC 15        REV 37   750-071976  CMUIANABAA     JNP10K-LC1101
  PIC 0              BUILTIN
Power Supply 0 REV 01   740-073147  CMUPADPBAA     JNP10K-PWR-DC
Power Supply 1 REV 01   740-073147  CMUPADPBAA     JNP10K-PWR-DC
Power Supply 2 REV 01   740-073147  CMUPADPBAA     JNP10K-PWR-DC
Power Supply 3 REV 01   740-073147  CMUPADPBAA     JNP10K-PWR-DC
Power Supply 4 REV 01   740-073147  CMUPADPBAA     JNP10K-PWR-DC
Power Supply 5 REV 01   740-073147  CMUPADPBAA     JNP10K-PWR-DC
Power Supply 6 REV 01   740-073147  CMUPADPBAA     JNP10K-PWR-DC

```

Power Supply 7	REV 01	740-073147	CMUPADPBAA	JNP10K-PWR-DC
Power Supply 8	REV 01	740-073147	CMUPADPBAA	JNP10K-PWR-DC
Power Supply 9	REV 01	740-073147	CMUPADPBAA	JNP10K-PWR-DC
Fan Tray 0				QFX5100-FAN-AFO
Fan Tray 1				QFX5100-FAN-AFO
SIB 0	REV 15	750-077140	CMUCAH6CAA	JNP10016-SF
SIB 1	REV 15	750-077140	CMUCAH6CAA	JNP10016-SF
SIB 2	REV 15	750-077140	CMUCAH6CAA	JNP10016-SF
SIB 3	REV 15	750-077140	CMUCAH6CAA	JNP10016-SF
SIB 4	REV 15	750-077140	CMUCAH6CAA	JNP10016-SF
SIB 5	REV 15	750-077140	CMUCAH6CAA	JNP10016-SF
FPD Board	REV 07	711-054687		

Locate the Chassis Serial Number on a PTX10016

The serial number ID label is located on a label on the right side of the chassis. See [Figure 167](#) on page [346](#) for the location on a PTX10016.

Figure 167: PTX10016 Serial Number Label

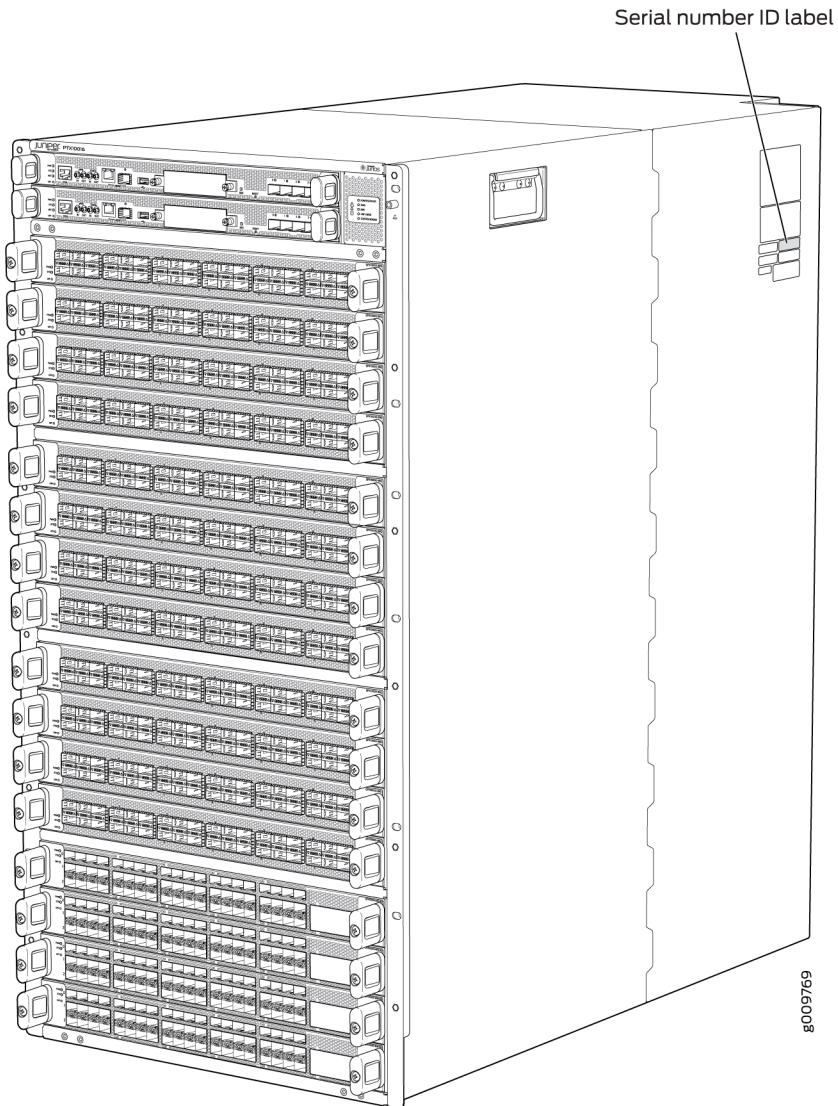

Locate the Serial Number ID Labels on PTX10016 Power Supplies

The power supplies installed in a PTX10016 are field-replaceable units (FRUs). For each FRU, you must remove the FRU from the router chassis to see the FRU serial number ID label.

- JNP10K-PWR-AC power supply—The serial number ID label is on the right side of the JNP10K-PWR-AC power supply. See [Figure 168 on page 347](#).

Figure 168: JNP10K-PWR-AC Power Supply Serial Number Location

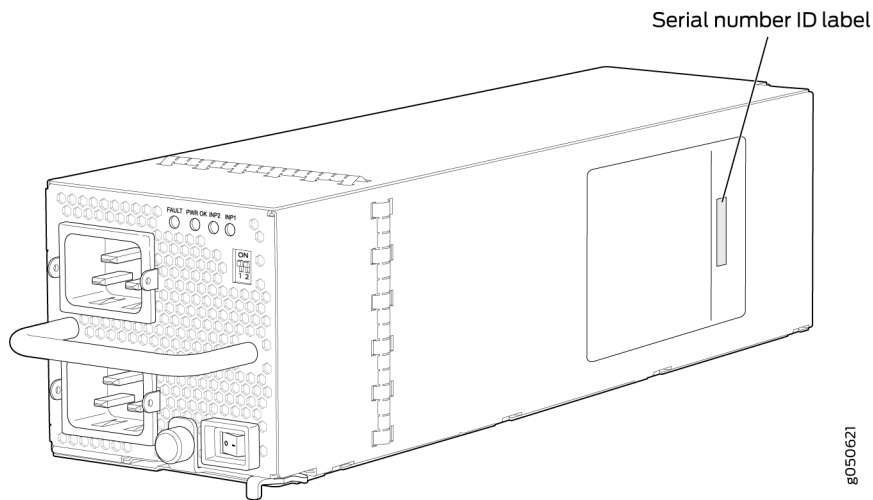

- JNP10K-PWR-AC2 power supply—The serial ID label is on the right side of the power supply. See [Figure 169 on page 348](#).

Figure 169: JNP10K-PWR-AC2 Power Supply Serial Number Location

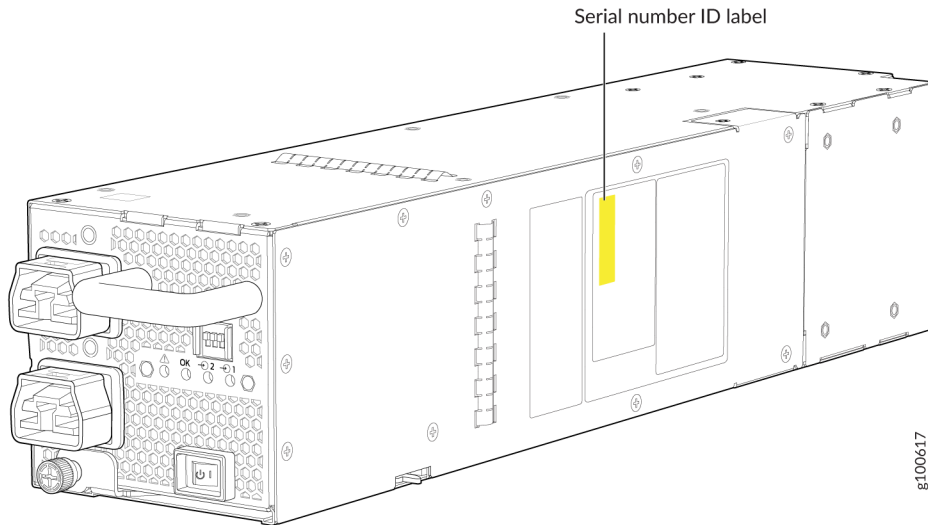

- JNP10K-PWR-DC power supply—The serial number ID label is on the left side of the DC power supply. See [Figure 170 on page 349](#).

Figure 170: JNP10K-PWR DC Power Supply Serial Number Location

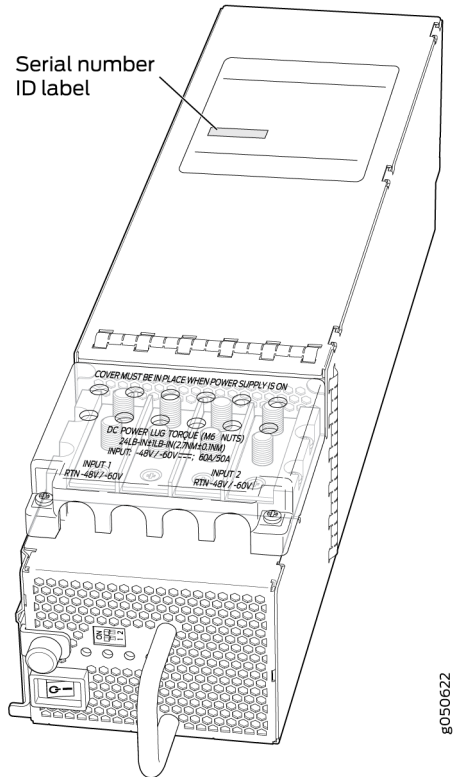

- JNP10K-PWR-DC2 power supply—The serial number ID label is on the left side of the power supply. See [Figure 171 on page 350](#).

Figure 171: JNP10K-PWR-DC2 Power Supply Serial Number Location

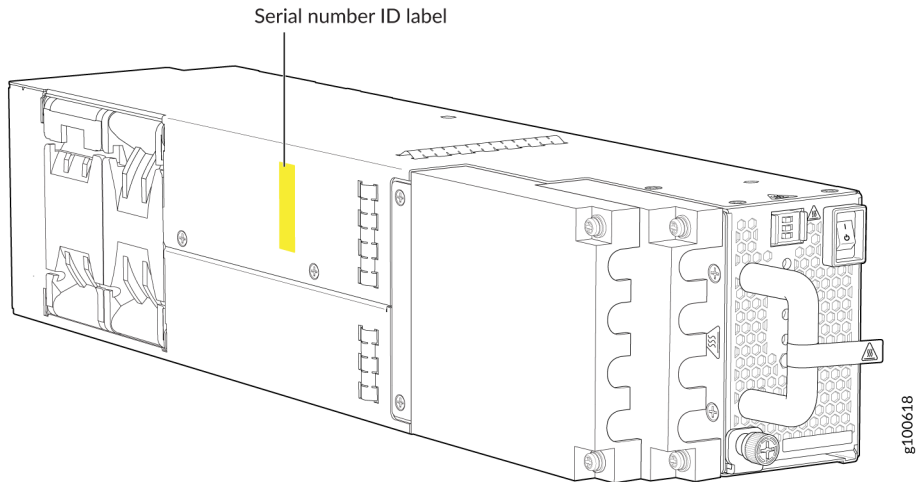

Locate the Serial Number ID Labels on PTX10016 Fan Trays and Fan Tray Controllers

The two fan trays and their associated fan tray controllers installed in a PTX10016 are field-replaceable units (FRUs). For each FRU, you must remove the FRU from the router chassis to see the FRU serial number ID label.

- Fan tray–The serial number ID label for all fan tray models (JNP10016-FAN and JNP10016-FAN2) is located on the inside of the fan tray at the base of the fan tray Control Board. See [Figure 172 on page 351](#).

Figure 172: PTX10016 Fan Tray Serial Number Location

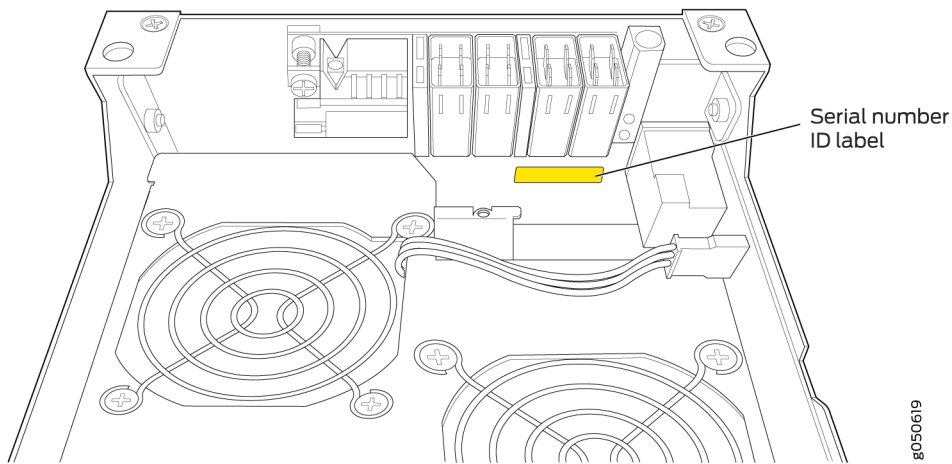

- Fan tray controller–The serial number ID label for all fan tray controller models (JNP10016-FAN-CTRL and JNP10016-FTC2) is located on the top of the fan tray controller. See [Figure 173 on page 351](#).

Figure 173: PTX10016 Fan Tray Controller Serial Number Location

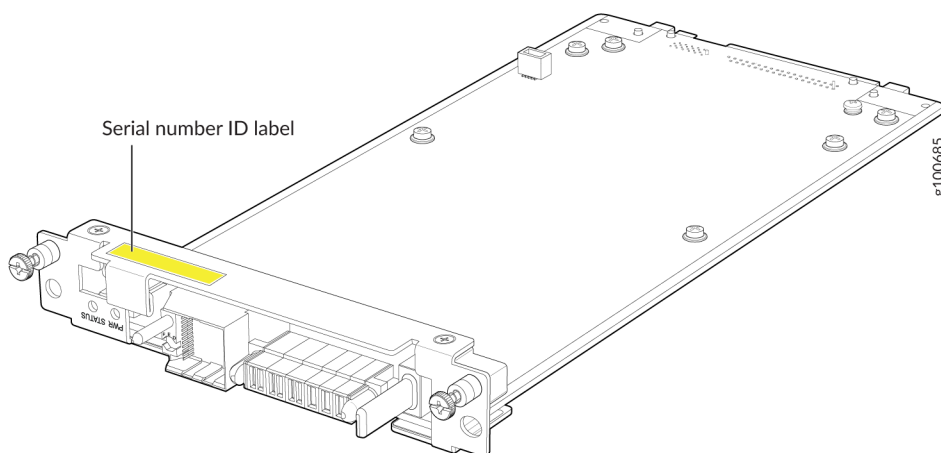

Locate the Serial Number ID Labels on PTX10016 Routing and Control Boards

The serial number ID label for a Routing and Control Board (RCB) is located on the connector end of the unit. See [Figure 174 on page 352](#).

Figure 174: PTX10016 Routing and Control Board Serial Number Location

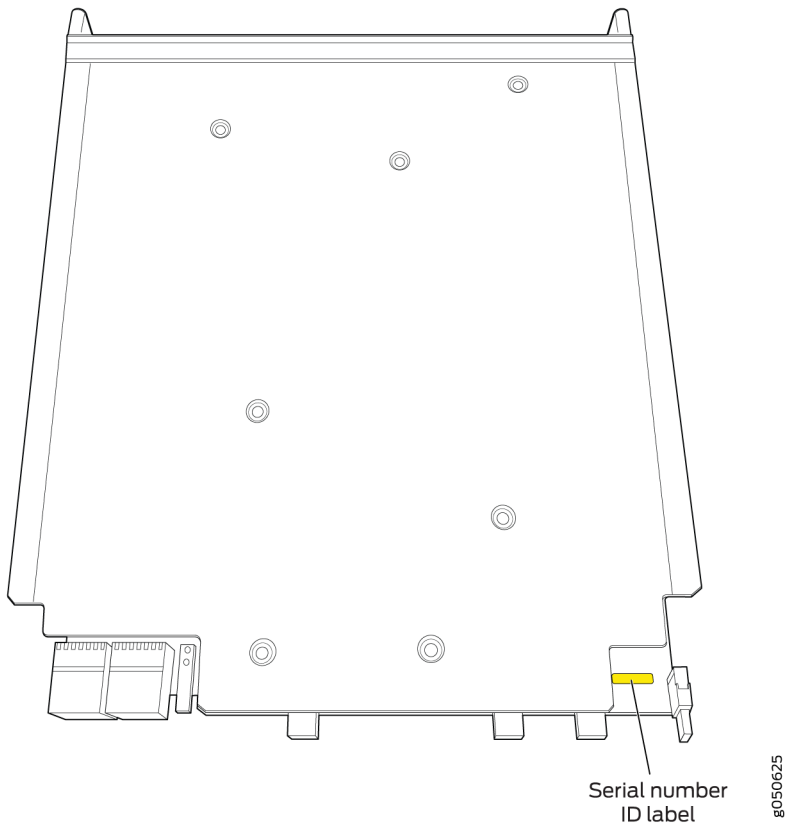

Locate the Serial Number ID Labels on a PTX10016 Line Card

The serial number ID label for a line card is located on the connector end of the card. See [Figure 175 on page 353](#).

Figure 175: PTX10016 Line Card Serial Number Location

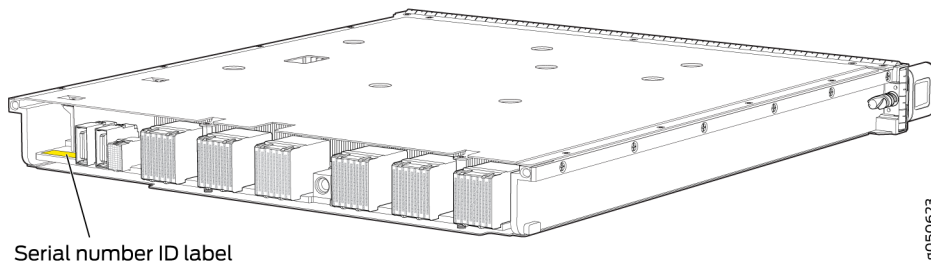

Locate the Serial Number ID Labels on a PTX10016 Switch Interface Board (SIB)

The serial number ID label for a SIB is located on the printed circuit board. See [Figure 176 on page 353](#).

Figure 176: PTX10016 SIB Serial Number Location

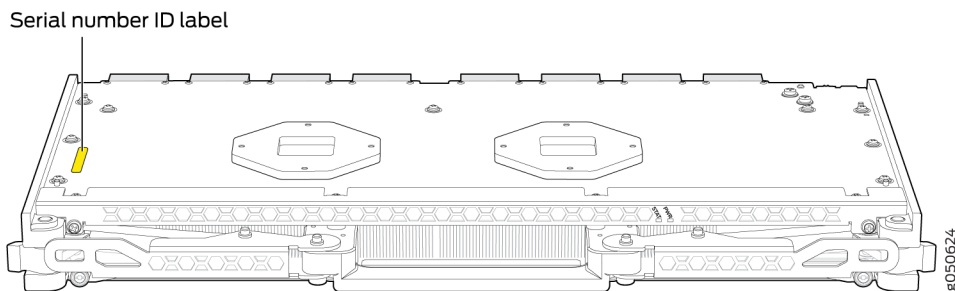

Locate the Serial Number ID Label on a PTX10016 SATA SSD

The serial number for a SATA SSD is located on top of the drive. See [Figure 177 on page 354](#).

Figure 177: PTX10016 SATA SSD Serial Number Location

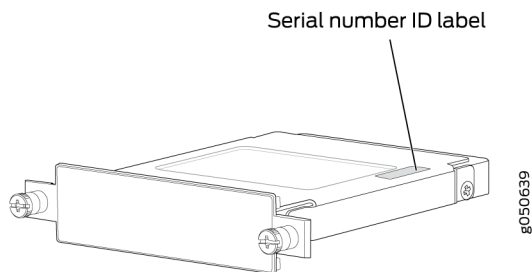

SEE ALSO

[PTX10016 Packet Transport Router Description | 2](#)

Contact Customer Support to Obtain a Return Materials Authorization for a PTX10016 Router or Component

If you are returning a PTX10016 router or component to Juniper Networks for repair or replacement, you must first obtain a Return Materials Authorization (RMA) from the Juniper Networks Technical Assistance Center (JTAC).

After locating the serial number of the device or component you want to return, open a service request with Juniper Networks Technical Assistance Center (JTAC) on the Web or by telephone.

For instructions on locating the serial number of the device or component you want to return, see the following device instructions:

- ["Locate the Serial Number on a PTX10016 Router or Component" on page 343](#)

Before you request an RMA from JTAC, be prepared to provide the following information:

- Your existing service request number, if you have one
- Serial number of the component
- Your name, organization name, telephone number, fax number, and shipping address

- Details of the failure or problem
- Type of activity being performed on the device when the problem occurred
- Configuration data displayed by one or more show commands

You can contact JTAC 24 hours a day, seven days a week on the Web or by telephone:

- Service Request Manager: <https://support.juniper.net/support/>
- Telephone: +1-888-314-JTAC (+1-888-314-5822), toll-free in the USA, Canada, and Mexico

NOTE: For international or direct-dial options in countries without toll-free numbers, see <https://www.juniper.net/support/requesting-support.html>.

If you are contacting JTAC by telephone, enter your 12-digit service request number followed by the pound (#) key for an existing case, or press the star (*) key to be routed to the next available support engineer.

The support representative validates your request and issues an RMA number for return of the component.

How to Pack a PTX10016 or Component for Shipping

IN THIS SECTION

- [How to Pack a PTX10016 Chassis for Shipping | 356](#)
- [How to Pack PTX10016 Components for Shipping | 359](#)

Follow this procedure if you are returning a PTX10016 chassis or component to Juniper Networks for repair or replacement.

Before you pack a PTX10016 or component:

- Ensure that you have taken the necessary precautions to prevent electrostatic discharge (ESD) damage. See "[Prevention of Electrostatic Discharge Damage](#)" on page 388.
- Pack your chassis or component using one of these materials:

- Use the packing material from the replacement chassis or component
- Retrieve the original shipping carton and packing materials

Contact your JTAC representative if you do not have these materials, to learn about approved packing materials. See ["Contact Customer Support to Obtain a Return Materials Authorization for a PTX10016 Router or Component" on page 354.](#)

Ensure that you have the following parts and tools available:

- ESD grounding strap.
- Antistatic bag, one for each component.
- If you are returning the chassis:
 - A 13/32-in. or 10-mm open-end or socket wrench to install the bracket bolts on the chassis and shipping pallet
 - An appropriate screwdriver for the mounting screws used on your rack.

This topic covers:

How to Pack a PTX10016 Chassis for Shipping

The PTX10016 is shipped in a cardboard box that has a two-layer wooden pallet base with foam cushioning between the layers. The router chassis is bolted to the pallet base with four pallet fasteners,

two on each side of the chassis. See [Figure 178 on page 357](#) for the stacking configuration of the PTX10016 router.

Figure 178: Configuration for Packing the PTX10016 Chassis

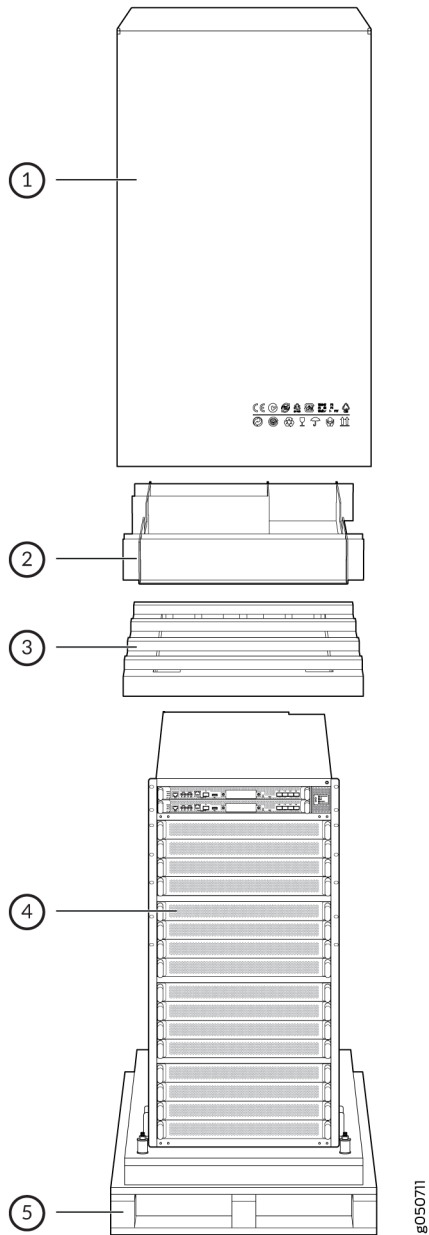

To pack a PTX10016 for shipping:

1. Power down the chassis and remove the power cables. See ["Power Off a PTX10016 Router" on page 330](#).
2. Remove the cables that connect the PTX10016 to all external devices.

3. Remove all line cards and pack them in their original shipping containers. See ["How to Pack a PTX10016 or Component for Shipping" on page 355.](#)
4. Install covers over blank slots.
Leave components that came installed in the chassis in the chassis, such as the Control Boards or power supplies.
5. Move the wooden pallet and packing material to a staging area as close to the router as possible. Make sure there is enough space to move the chassis from the rack to the wooden pallet.
6. Position a mechanical lift under the device. If a mechanical lift is not available, have three people support the weight of the router while another person uses the screwdriver to remove the front mounting screws that attach the chassis mounting brackets to the rack. For PTX10016 removal, see ["Remove the PTX10016 from a Four-Post Rack Using a Mechanical Lift" on page 333.](#)
7. Remove the router from the rack (see ["PTX10016 Chassis Lifting Guidelines" on page 369](#)) and place the router on the shipping pallet. Position the router on the pallet so that the front of the router is facing the silkscreened "front" mark on the pallet. The pallet also has crop marks to guide you in positioning the chassis
8. Use the 13/32-in. or 10-mm open-end or socket wrench to install the four sets of brackets and bolts that secure the chassis to the wooden pallet.
9. Slide the plastic cover over the router chassis. The plastic cover is part of the router's original packing materials.
10. Place the packing foam on top of and around the router.
11. Place the power cords in the box.
12. Remove the rack mount kit from the rack and place it and the connecting screws in the accessory box.
13. If you are returning accessories or FRUs with the router, pack them as instructed in ["How to Pack PTX10016 Components for Shipping" on page 359.](#)
14. Verify that all accessories are present. See ["Compare the PTX10016 Order to the Packing List" on page 204.](#)
15. Slide the cardboard box over the chassis, making sure that the arrows on the box point up and the pallet fasteners to secure the cardboard box to the wooden pallet are near the bottom.

16. Attach the cardboard box to the wooden pallet by screwing two screws into each of the four pallet fasteners. See [Figure 179 on page 359](#).

Figure 179: Attach the PTX10016 to the Pallet

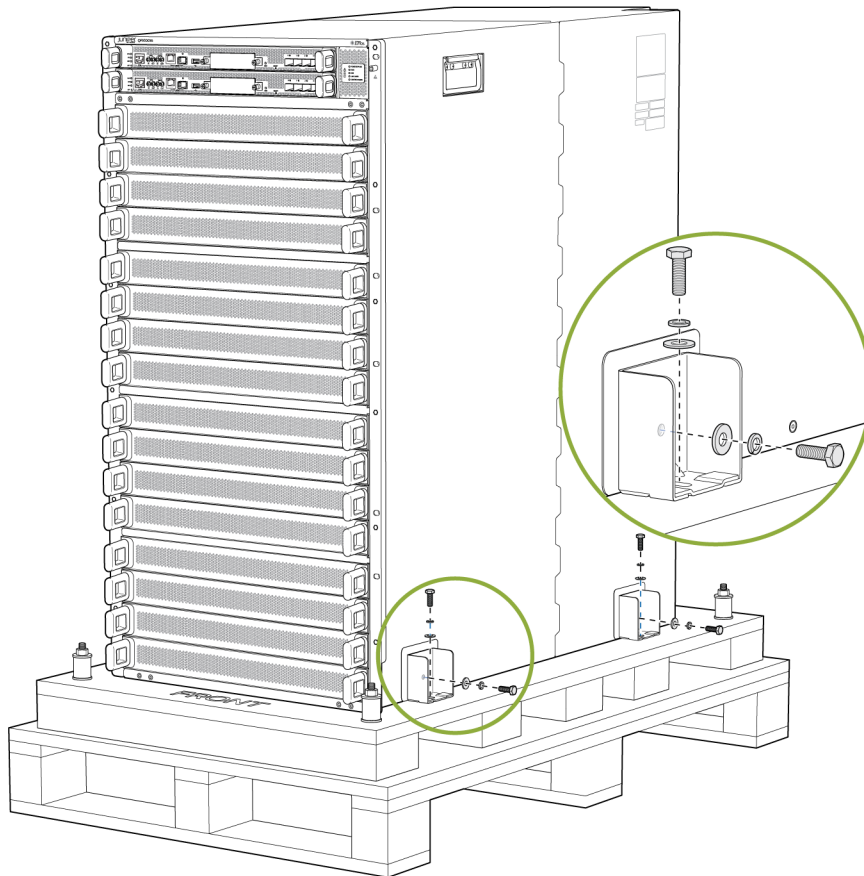

8050712

17. Write the RMA number on the exterior of the box to ensure proper tracking.

How to Pack PTX10016 Components for Shipping

Before you begin packing a router component, ensure that you have the following parts and tools available:

- Antistatic bag, one for each component
- Electrostatic discharge (ESD) grounding strap



CAUTION: Do not stack router components. Return individual components in separate boxes if they do not fit together on one level in the shipping box.

To pack and ship PTX10016 components:

1. Place individual FRUs in antistatic bags.
2. Use the original packing materials if they are available. If the original packing materials are not available, ensure the component is adequately packed to prevent damage during transit. The packing material you use must be able to support the weight of the component.
3. Ensure that the components are adequately protected with packing materials and packed so that the pieces are prevented from moving around inside the carton.
4. Close the top of the cardboard shipping box and seal it with packing tape.
5. Write the RMA number on the exterior of the box to ensure proper tracking.

RELATED DOCUMENTATION

[PTX10016 Packet Transport Router Description | 2](#)

[How to Pack a PTX10016 or Component for Shipping | 355](#)

7

CHAPTER

Safety and Compliance Information

- General Safety Guidelines and Warnings | 363
- Definitions of Safety Warning Levels | 364
- Qualified Personnel Warning | 366
- Warning Statement for Norway and Sweden | 366
- Fire Safety Requirements | 367
- Installation Instructions Warning | 368
- PTX10016 Chassis Lifting Guidelines | 369
- Restricted Access Warning | 369
- Ramp Warning | 371
- Rack-Mounting and Cabinet-Mounting Warnings | 371
- Grounded Equipment Warning | 375
- Radiation from Open Port Apertures Warning | 376
- Laser and LED Safety Guidelines and Warnings | 377
- Maintenance and Operational Safety Guidelines and Warnings | 380
- General Electrical Safety Guidelines and Warnings | 386
- Action to Take After an Electrical Accident | 387
- Prevention of Electrostatic Discharge Damage | 388
- AC Power Electrical Safety Guidelines | 389
- AC Power Disconnection Warning | 390

DC Power Electrical Safety Guidelines for PTX10008 and PTX10016 Routers | 391

DC Power Copper Conductors Warning | 392

DC Power Disconnection Warning | 393

DC Power Grounding Requirements and Warning | 394

DC Power Wiring Sequence Warning | 395

DC Power Wiring Terminations Warning | 397

Multiple Power Supplies Disconnection Warning | 398

TN Power Warning | 399

Fire Safety Requirements | 400

PTX10008 and PTX10016 Agency Approvals and Compliance Statements | 401

General Safety Guidelines and Warnings

The following guidelines help ensure your safety and protect the device from damage. The list of guidelines might not address all potentially hazardous situations in your working environment, so be alert and exercise good judgment at all times.

- Perform only the procedures explicitly described in the hardware documentation for this device. Make sure that only authorized service personnel perform other system services.
- Keep the area around the device clear and free from dust before, during, and after installation.
- Keep tools away from areas where people could trip over them while walking.
- Do not wear loose clothing or jewelry, such as rings, bracelets, or chains, which could become caught in the device.
- Wear safety glasses if you are working under any conditions that could be hazardous to your eyes.
- Do not perform any actions that create a potential hazard to people or make the equipment unsafe.
- Never attempt to lift an object that is too heavy for one person to handle.
- Never install or manipulate wiring during electrical storms.
- Never install electrical jacks in wet locations unless the jacks are specifically designed for wet environments.
- Operate the device only when it is properly grounded.
- Follow the instructions in this guide to properly ground the device to earth.
- Replace fuses only with fuses of the same type and rating.
- Do not open or remove chassis covers or sheet-metal parts unless instructions are provided in the hardware documentation for this device. Such an action could cause severe electrical shock.
- Do not push or force any objects through any opening in the chassis frame. Such an action could result in electrical shock or fire.
- Avoid spilling liquid onto the chassis or onto any device component. Such an action could cause electrical shock or damage the device.
- Avoid touching uninsulated electrical wires or terminals that have not been disconnected from their power source. Such an action could cause electrical shock.

- Some parts of the chassis, including AC and DC power supply surfaces, power supply unit handles, SFB card handles, and fan tray handles might become hot. The following label provides the warning of the hot surfaces on the chassis:



- Always ensure that all modules, power supplies, and cover panels are fully inserted and that the installation screws are fully tightened.

Definitions of Safety Warning Levels

The documentation uses the following levels of safety warnings (there are two *Warning* formats):

NOTE: You might find this information helpful in a particular situation, or you might overlook this important information if it was not highlighted in a Note.



CAUTION: You need to observe the specified guidelines to prevent minor injury or discomfort to you or severe damage to the device.

Attention Veillez à respecter les consignes indiquées pour éviter toute incommodité ou blessure légère, voire des dégâts graves pour l'appareil.



LASER WARNING: This symbol alerts you to the risk of personal injury from a laser.

Avertissement Ce symbole signale un risque de blessure provoquée par rayon laser.



WARNING: This symbol means danger. You are in a situation that could cause bodily injury. Before you work on any equipment, be aware of the hazards involved with electrical circuitry and be familiar with standard practices for preventing accidents.

Waarschuwing Dit waarschuwingssymbool betekent gevaar. U verkeert in een situatie die lichamelijk letsel kan veroorzaken. Voordat u aan enige apparatuur gaat werken,

dient u zich bewust te zijn van de bij elektrische schakelingen betrokken risico's en dient u op de hoogte te zijn van standaard maatregelen om ongelukken te voorkomen.

Varoitus Tämä varoitusmerkki merkitsee vaaraa. Olet tilanteessa, joka voi johtaa ruumiinvammaan. Ennen kuin työskentelet minkään laitteiston parissa, ota selvää sähkökytkentöihin liittyvistä vaaroista ja tavanomaisista onnettomuuksien ehkäisykeinoista.

Avertissement Ce symbole d'avertissement indique un danger. Vous vous trouvez dans une situation pouvant causer des blessures ou des dommages corporels. Avant de travailler sur un équipement, soyez conscient des dangers posés par les circuits électriques et familiarisez-vous avec les procédures couramment utilisées pour éviter les accidents.

Warnung Dieses Warnsymbol bedeutet Gefahr. Sie befinden sich in einer Situation, die zu einer Körperverletzung führen könnte. Bevor Sie mit der Arbeit an irgendeinem Gerät beginnen, seien Sie sich der mit elektrischen Stromkreisen verbundenen Gefahren und der Standardpraktiken zur Vermeidung von Unfällen bewußt.

Avvertenza Questo simbolo di avvertenza indica un pericolo. La situazione potrebbe causare infortuni alle persone. Prima di lavorare su qualsiasi apparecchiatura, occorre conoscere i pericoli relativi ai circuiti elettrici ed essere al corrente delle pratiche standard per la prevenzione di incidenti.

Advarsel Dette varselsymbolet betyr fare. Du befinner deg i en situasjon som kan føre til personskade. Før du utfører arbeid på utstyr, må du være oppmerksom på de faremomentene som elektriske kretser innebærer, samt gjøre deg kjent med vanlig praksis når det gjelder å unngå ulykker.

Aviso Este símbolo de aviso indica perigo. Encontra-se numa situação que lhe poderá causar danos físicos. Antes de começar a trabalhar com qualquer equipamento, familiarize-se com os perigos relacionados com circuitos eléctricos, e com quaisquer práticas comuns que possam prevenir possíveis acidentes.

¡Atención! Este símbolo de aviso significa peligro. Existe riesgo para su integridad física. Antes de manipular cualquier equipo, considerar los riesgos que entraña la corriente eléctrica y familiarizarse con los procedimientos estándar de prevención de accidentes.

Varning! Denna varningssymbol signalerar fara. Du befinner dig i en situation som kan leda till personskada. Innan du utför arbete på någon utrustning måste du vara medveten om farorna med elkretsar och känna till vanligt förfarande för att förebygga skador.

Qualified Personnel Warning



WARNING: Only trained and qualified personnel should install or replace the device.

Waarschuwing Installatie en reparaties mogen uitsluitend door getraind en bevoegd personeel uitgevoerd worden.

Varoitus Ainoastaan koulutettu ja pätevä henkilökunta saa asentaa tai vaihtaa tämän laitteen.

Avertissement Tout installation ou remplacement de l'appareil doit être réalisé par du personnel qualifié et compétent.

Warnung Gerät nur von geschultem, qualifiziertem Personal installieren oder auswechseln lassen.

Avvertenza Solo personale addestrato e qualificato deve essere autorizzato ad installare o sostituire questo apparecchio.

Advarsel Kun kvalifisert personell med riktig opplæring bør montere eller bytte ut dette utstyret.

Aviso Este equipamento deverá ser instalado ou substituído apenas por pessoal devidamente treinado e qualificado.

¡Atención! Estos equipos deben ser instalados y reemplazados exclusivamente por personal técnico adecuadamente preparado y capacitado.

Varning! Denna utrustning ska endast installeras och bytas ut av utbildad och kvalificerad personal.

Warning Statement for Norway and Sweden



WARNING: The equipment must be connected to an earthed mains socket-outlet.

Advarsel Apparatet skal kobles til en jordet stikkontakt.

Varning! Apparaten skall anslutas till jordat nätuttag.

Fire Safety Requirements

IN THIS SECTION

- [Fire Suppression | 367](#)
- [Fire Suppression Equipment | 367](#)

In the event of a fire emergency, the safety of people is the primary concern. You should establish procedures for protecting people in the event of a fire emergency, provide safety training, and properly provision fire-control equipment and fire extinguishers.

In addition, you should establish procedures to protect your equipment in the event of a fire emergency. Juniper Networks products should be installed in an environment suitable for electronic equipment. We recommend that fire suppression equipment be available in the event of a fire in the vicinity of the equipment and that all local fire, safety, and electrical codes and ordinances be observed when you install and operate your equipment.

Fire Suppression

In the event of an electrical hazard or an electrical fire, you should first turn power off to the equipment at the source. Then use a Type C fire extinguisher, which uses noncorrosive fire retardants, to extinguish the fire.

Fire Suppression Equipment

Type C fire extinguishers, which use noncorrosive fire retardants such as carbon dioxide and Halotron™, are most effective for suppressing electrical fires. Type C fire extinguishers displace oxygen from the point of combustion to eliminate the fire. For extinguishing fire on or around equipment that draws air from the environment for cooling, you should use this type of inert oxygen displacement extinguisher instead of an extinguisher that leaves residues on equipment.

Do not use multipurpose Type ABC chemical fire extinguishers (dry chemical fire extinguishers). The primary ingredient in these fire extinguishers is monoammonium phosphate, which is very sticky and

difficult to clean. In addition, in the presence of minute amounts of moisture, monoammonium phosphate can become highly corrosive and corrodes most metals.

Any equipment in a room in which a chemical fire extinguisher has been discharged is subject to premature failure and unreliable operation. The equipment is considered to be irreparably damaged.

NOTE: To keep warranties effective, do not use a dry chemical fire extinguisher to control a fire at or near a Juniper Networks device. If a dry chemical fire extinguisher is used, the unit is no longer eligible for coverage under a service agreement.

We recommend that you dispose of any irreparably damaged equipment in an environmentally responsible manner.

Installation Instructions Warning



WARNING: Read the installation instructions before you connect the device to a power source.

Waarschuwing Raadpleeg de installatie-aanwijzingen voordat u het systeem met de voeding verbindt.

Varoitus Lue asennusohjeet ennen järjestelmän yhdistämistä virtälähteeseen.

Avertissement Avant de brancher le système sur la source d'alimentation, consulter les directives d'installation.

Warnung Lesen Sie die Installationsanweisungen, bevor Sie das System an die Stromquelle anschließen.

Avvertenza Consultare le istruzioni di installazione prima di collegare il sistema all'alimentatore.

Advarsel Les installasjonsinstruksjonene før systemet kobles til strømkilden.

Aviso Leia as instruções de instalação antes de ligar o sistema à sua fonte de energia.

¡Atención! Ver las instrucciones de instalación antes de conectar el sistema a la red de alimentación.

Varning! Läs installationsanvisningarna innan du kopplar systemet till dess strömförsörjningsenhet.

PTX10016 Chassis Lifting Guidelines

The weight of a fully loaded PTX10016 base AC configuration is approximately 522 lbs (336.8 kg) and 596 lbs (270.34 kg) for the redundant AC configuration. Similarly, the weight of a redundant DC configuration is 591 lbs (268.1 kg). Observe the following guidelines for lifting and moving a PTX10016:



CAUTION: To avoid serious injury, do not attempt to move the PTX10016 without a mechanical lift.

- Before installing a PTX10016, read the guidelines in "[PTX10016 Site Preparation Checklist](#)" on page [147](#) to verify that the intended site meets the specified power, environmental, and clearance requirements.
- Before moving the PTX10016, disconnect all external cables.
- When raising the PTX10016 into the rack using a mechanical lift, have one person lift and align the router with the rack while another person secures the router to the rack.

RELATED DOCUMENTATION

[General Safety Guidelines and Warnings | 363](#)

[Installation Instructions Warning | 368](#)

[Mount a PTX10016 in a Four-Post Rack Using a Mechanical Lift | 213](#)

Restricted Access Warning



WARNING: This unit is intended for installation in restricted access areas. A restricted access area is an area to which access can be gained only by service personnel through the use of a special tool, lock and key, or other means of security, and which is controlled by the authority responsible for the location.

Waarschuwing Dit toestel is bedoeld voor installatie op plaatsen met beperkte toegang. Een plaats met beperkte toegang is een plaats waar toegang slechts door servicepersoneel verkregen kan worden door middel van een speciaal instrument, een

slot en sleutel, of een ander veiligheidsmiddel, en welke beheerd wordt door de overheidsinstantie die verantwoordelijk is voor de locatie.

Varoitus Tämä laite on tarkoitettu asennettavaksi paikkaan, johon pääsy on rajoitettua. Paikka, johon pääsy on rajoitettua, tarkoittaa paikkaa, johon vain huoltohenkilöstö pääsee jonkin erikoistyökalun, lukkoon sopivan avaimen tai jonkin muun turvalaitteen avulla ja joka on paikasta vastuussa olevien toimivaltaisten henkilöiden valvoma.

Avertissement Cet appareil est à installer dans des zones d'accès réservé. Ces dernières sont des zones auxquelles seul le personnel de service peut accéder en utilisant un outil spécial, un mécanisme de verrouillage et une clé, ou tout autre moyen de sécurité. L'accès aux zones de sécurité est sous le contrôle de l'autorité responsable de l'emplacement.

Warnung Diese Einheit ist zur Installation in Bereichen mit beschränktem Zutritt vorgesehen. Ein Bereich mit beschränktem Zutritt ist ein Bereich, zu dem nur Wartungspersonal mit einem Spezialwerkzeugs, Schloß und Schlüssel oder anderer Sicherheitsvorkehrungen Zugang hat, und der von dem für die Anlage zuständigen Gremium kontrolliert wird.

Avvertenza Questa unità deve essere installata in un'area ad accesso limitato. Un'area ad accesso limitato è un'area accessibile solo a personale di assistenza tramite un'attrezzo speciale, lucchetto, o altri dispositivi di sicurezza, ed è controllata dall'autorità responsabile della zona.

Advarsel Denne enheten er laget for installasjon i områder med begrenset adgang. Et område med begrenset adgang gir kun adgang til servicepersonale som bruker et spesielt verktøy, lås og nøkkel, eller en annen sikkerhetsanordning, og det kontrolleres av den autoriteten som er ansvarlig for området.

Aviso Esta unidade foi concebida para instalação em áreas de acesso restrito. Uma área de acesso restrito é uma área à qual apenas tem acesso o pessoal de serviço autorizado, que possui uma ferramenta, chave e fechadura especial, ou qualquer outra forma de segurança. Esta área é controlada pela autoridade responsável pelo local.

¡Atención! Esta unidad ha sido diseñada para instalarse en áreas de acceso restringido. Área de acceso restringido significa un área a la que solamente tiene acceso el personal de servicio mediante la utilización de una herramienta especial, cerradura con llave, o algún otro medio de seguridad, y que está bajo el control de la autoridad responsable del local.

Warning! Denna enhet är avsedd för installation i områden med begränsat tillträde. Ett område med begränsat tillträde får endast tillträdas av servicepersonal med ett speciellt

verktyg, lås och nyckel, eller annan säkerhetsanordning, och kontrolleras av den auktoritet som ansvarar för området.

Ramp Warning



WARNING: When installing the device, do not use a ramp inclined at more than 10 degrees.

Waarschuwing Gebruik een oprijplaat niet onder een hoek van meer dan 10 graden.

Varoitus Älä käytä sellaista kaltevaa pintaa, jonka kaltevuus ylittää 10 astetta.

Avertissement Ne pas utiliser une rampe dont l'inclinaison est supérieure à 10 degrés.

Warnung Keine Rampen mit einer Neigung von mehr als 10 Grad verwenden.

Avvertenza Non usare una rampa con pendenza superiore a 10 gradi.

Advarsel Bruk aldri en rampe som heller mer enn 10 grader.

Aviso Não utilize uma rampa com uma inclinação superior a 10 graus.

¡Atención! No usar una rampa inclinada más de 10 grados

Warning! Använd inte ramp med en lutning på mer än 10 grader.

Rack-Mounting and Cabinet-Mounting Warnings

Ensure that the rack or cabinet in which the device is installed is evenly and securely supported. Uneven mechanical loading could lead to a hazardous condition.



WARNING: To prevent bodily injury when mounting or servicing the device in a rack, take the following precautions to ensure that the system remains stable. The following directives help maintain your safety:

- The device must be installed in a rack that is secured to the building structure.

- The device should be mounted at the bottom of the rack if it is the only unit in the rack.
- When mounting the device on a partially filled rack, load the rack from the bottom to the top with the heaviest component at the bottom of the rack.
- If the rack is provided with stabilizing equipment, install the stabilizers before mounting or servicing the device in the rack.

Waarschuwing Om lichamelijk letsel te voorkomen wanneer u dit toestel in een rek monteert of het daar een servicebeurt geeft, moet u speciale voorzorgsmaatregelen nemen om ervoor te zorgen dat het toestel stabiel blijft. De onderstaande richtlijnen worden verstrekt om uw veiligheid te verzekeren:

- De Juniper Networks switch moet in een stellage worden geïnstalleerd die aan een bouwsel is verankerd.
- Dit toestel dient onderaan in het rek gemonteerd te worden als het toestel het enige in het rek is.
- Wanneer u dit toestel in een gedeeltelijk gevuld rek monteert, dient u het rek van onderen naar boven te laden met het zwaarste onderdeel onderaan in het rek.
- Als het rek voorzien is van stabiliseringshulpmiddelen, dient u de stabilisatoren te monteren voordat u het toestel in het rek monteert of het daar een servicebeurt geeft.

Varoitus Kun laite asetetaan telineeseen tai huolletaan sen ollessa telineessä, on noudatettava erityisiä varotoimia järjestelmän vakavuuden säilyttämiseksi, jotta vältetään loukkaantumiset. Noudata seuraavia turvallisuusohjeita:

- Juniper Networks switch on asennettava telineeseen, joka on kiinnitetty rakennukseen.
- Jos telineessä ei ole muita laitteita, aseta laite telineen alaosaan.
- Jos laite asetetaan osaksi täytettyyn telineeseen, aloita kuormittaminen sen alaosasta kaikkein raskaimmalla esineellä ja siirry sitten sen yläosaan.
- Jos telinettä varten on vakaimet, asenna ne ennen laitteen asettamista telineeseen tai sen huoltamista siinä.

Avertissement Pour éviter toute blessure corporelle pendant les opérations de montage ou de réparation de cette unité en casier, il convient de prendre des précautions

spéciales afin de maintenir la stabilité du système. Les directives ci-dessous sont destinées à assurer la protection du personnel:

- Le rack sur lequel est monté le Juniper Networks switch doit être fixé à la structure du bâtiment.
- Si cette unité constitue la seule unité montée en casier, elle doit être placée dans le bas.
- Si cette unité est montée dans un casier partiellement rempli, charger le casier de bas en haut en plaçant l'élément le plus lourd dans le bas.
- Si le casier est équipé de dispositifs stabilisateurs, installer les stabilisateurs avant de monter ou de réparer l'unité en casier.

Warnung Zur Vermeidung von Körperverletzung beim Anbringen oder Warten dieser Einheit in einem Gestell müssen Sie besondere Vorkehrungen treffen, um sicherzustellen, daß das System stabil bleibt. Die folgenden Richtlinien sollen zur Gewährleistung Ihrer Sicherheit dienen:

- Der Juniper Networks switch muß in einem Gestell installiert werden, das in der Gebäudestruktur verankert ist.
- Wenn diese Einheit die einzige im Gestell ist, sollte sie unten im Gestell angebracht werden.
- Bei Anbringung dieser Einheit in einem zum Teil gefüllten Gestell ist das Gestell von unten nach oben zu laden, wobei das schwerste Bauteil unten im Gestell anzubringen ist.
- Wird das Gestell mit Stabilisierungszubehör geliefert, sind zuerst die Stabilisatoren zu installieren, bevor Sie die Einheit im Gestell anbringen oder sie warten.

Avvertenza Per evitare infortuni fisici durante il montaggio o la manutenzione di questa unità in un supporto, occorre osservare speciali precauzioni per garantire che il sistema rimanga stabile. Le seguenti direttive vengono fornite per garantire la sicurezza personale:

- Il Juniper Networks switch deve essere installato in un telaio, il quale deve essere fissato alla struttura dell'edificio.
- Questa unità deve venire montata sul fondo del supporto, se si tratta dell'unica unità da montare nel supporto.

- Quando questa unità viene montata in un supporto parzialmente pieno, caricare il supporto dal basso all'alto, con il componente più pesante sistemato sul fondo del supporto.
- Se il supporto è dotato di dispositivi stabilizzanti, installare tali dispositivi prima di montare o di procedere alla manutenzione dell'unità nel supporto.

Advarsel Unngå fysiske skader under montering eller reparasjonsarbeid på denne enheten når den befinner seg i et kabinett. Vær nøye med at systemet er stabilt. Følgende retningslinjer er gitt for å verne om sikkerheten:

- Juniper Networks switch må installeres i et stativ som er forankret til bygningsstrukturen.
- Denne enheten bør monteres nederst i kabinettet hvis dette er den eneste enheten i kabinettet.
- Ved montering av denne enheten i et kabinett som er delvis fylt, skal kabinettet lastes fra bunnen og opp med den tyngste komponenten nederst i kabinettet.
- Hvis kabinettet er utstyrt med stabiliseringsutstyr, skal stabilisatorene installeres før montering eller utføring av reparasjonsarbeid på enheten i kabinettet.

Aviso Para se prevenir contra danos corporais ao montar ou reparar esta unidade numa estante, deverá tomar precauções especiais para se certificar de que o sistema possui um suporte estável. As seguintes directrizes ajudá-lo-ão a efectuar o seu trabalho com segurança:

- O Juniper Networks switch deverá ser instalado numa prateleira fixa à estrutura do edifício.
- Esta unidade deverá ser montada na parte inferior da estante, caso seja esta a única unidade a ser montada.
- Ao montar esta unidade numa estante parcialmente ocupada, coloque os itens mais pesados na parte inferior da estante, arrumando-os de baixo para cima.
- Se a estante possuir um dispositivo de estabilização, instale-o antes de montar ou reparar a unidade.

¡Atención! Para evitar lesiones durante el montaje de este equipo sobre un bastidor, oerriormente durante su mantenimiento, se debe poner mucho cuidado en que el sistema quede bien estable. Para garantizar su seguridad, proceda según las siguientes instrucciones:

- El Juniper Networks switch debe instalarse en un bastidor fijado a la estructura del edificio.
- Colocar el equipo en la parte inferior del bastidor, cuando sea la única unidad en el mismo.
- Cuando este equipo se vaya a instalar en un bastidor parcialmente ocupado, comenzar la instalación desde la parte inferior hacia la superior colocando el equipo más pesado en la parte inferior.
- Si el bastidor dispone de dispositivos estabilizadores, instalar éstos antes de montar o proceder al mantenimiento del equipo instalado en el bastidor.

Varning! För att undvika kroppsskada när du installerar eller utför underhållsarbete på denna enhet på en ställning måste du vidta särskilda försiktighetsåtgärder för att försäkra dig om att systemet står stadigt. Följande riktlinjer ges för att trygga din säkerhet:

- Juniper Networks switch måste installeras i en ställning som är förankrad i byggnadens struktur.
- Om denna enhet är den enda enheten på ställningen skall den installeras längst ned på ställningen.
- Om denna enhet installeras på en delvis fylld ställning skall ställningen fyllas nedifrån och upp, med de tyngsta enheterna längst ned på ställningen.
- Om ställningen är försedd med stabiliseringsdon skall dessa monteras fast innan enheten installeras eller underhålls på ställningen.

Grounded Equipment Warning



WARNING: This device must be properly grounded at all times. Follow the instructions in this guide to properly ground the device to earth.

Waarschuwing Dit apparaat moet altijd goed geaard zijn. Volg de instructies in deze gids om het apparaat goed te aarden.

Varoitus Laitteen on oltava pysyvästi maadoitettu. Maadoita laite asianmukaisesti noudattamalla tämän oppaan ohjeita.

Avertissement L'appareil doit être correctement mis à la terre à tout moment. Suivez les instructions de ce guide pour correctement mettre l'appareil à la terre.

Warnung Das Gerät muss immer ordnungsgemäß geerdet sein. Befolgen Sie die Anweisungen in dieser Anleitung, um das Gerät ordnungsgemäß zu erden.

Avvertenza Questo dispositivo deve sempre disporre di una connessione a massa. Seguire le istruzioni indicate in questa guida per connettere correttamente il dispositivo a massa.

Advarsel Denne enheten på jordes skikkelig hele tiden. Følg instruksjonene i denne veiledningen for å jorde enheten.

Aviso Este equipamento deverá estar ligado à terra. Siga las instrucciones en esta guía para conectar correctamente este dispositivo a tierra.

¡Atención! Este dispositivo debe estar correctamente conectado a tierra en todo momento. Siga las instrucciones en esta guía para conectar correctamente este dispositivo a tierra.

Varning! Den här enheten måste vara ordentligt jordad. Följ instruktionerna i den här guiden för att jorda enheten ordentligt.

Radiation from Open Port Apertures Warning



LASER WARNING: Because invisible radiation might be emitted from the aperture of the port when no fiber cable is connected, avoid exposure to radiation and do not stare into open apertures.

Waarschuwing Aangezien onzichtbare straling vanuit de opening van de poort kan komen als er geen fiberkabel aangesloten is, dient blootstelling aan straling en het kijken in open openingen vermeden te worden.

Varoitus Koska portin aukosta voi emittoitua näkymätöntä säteilyä, kun kuitukaapelia ei ole kytkettynä, vältä säteilylle altistumista äläkä katso avoimiin aukkoihin.

Avertissement Des radiations invisibles à l'il nu pouvant traverser l'ouverture du port lorsqu'aucun câble en fibre optique n'y est connecté, il est recommandé de ne pas regarder fixement l'intérieur de ces ouvertures.

Warnung Aus der Port-Öffnung können unsichtbare Strahlen emittieren, wenn kein Glasfaserkabel angeschlossen ist. Vermeiden Sie es, sich den Strahlungen auszusetzen, und starren Sie nicht in die Öffnungen!

Avvertenza Quando i cavi in fibra non sono inseriti, radiazioni invisibili possono essere emesse attraverso l'apertura della porta. Evitate di esporvi alle radiazioni e non guardate direttamente nelle aperture.

Advarsel Unngå utsettelse for stråling, og stirr ikke inn i åpninger som er åpne, fordi usynlig stråling kan emitteres fra portens åpning når det ikke er tilkoblet en fiberkabel.

Aviso Dada a possibilidade de emissão de radiação invisível através do orifício da via de acesso, quando esta não tiver nenhum cabo de fibra conectado, deverá evitar an EXposição à radiação e não deverá olhar fixamente para orifícios que se encontrarem a descoberto.

¡Atención! Debido a que la apertura del puerto puede emitir radiación invisible cuando no existe un cable de fibra conectado, evite mirar directamente a las aperturas para no exponerse a la radiación.

Warning! Osynlig stråling kan avges från en portöppning utan ansluten fiberkabel och du bör därför undvika att bli utsatt för stråling genom att inte stirra in i oskyddade öppningar.

Laser and LED Safety Guidelines and Warnings

IN THIS SECTION

- [General Laser Safety Guidelines | 378](#)
- [Class 1 Laser Product Warning | 378](#)
- [Class 1 LED Product Warning | 379](#)
- [Laser Beam Warning | 379](#)

Juniper Networks devices are equipped with laser transmitters, which are considered a Class 1 Laser Product by the U.S. Food and Drug Administration and are evaluated as a Class 1 Laser Product per EN 60825-1 requirements.

Observe the following guidelines and warnings:

General Laser Safety Guidelines

When working around ports that support optical transceivers, observe the following safety guidelines to prevent eye injury:

- Do not look into unterminated ports or at fibers that connect to unknown sources.
- Do not examine unterminated optical ports with optical instruments.
- Avoid direct exposure to the beam.



LASER WARNING: Unterminated optical connectors can emit invisible laser radiation. The lens in the human eye focuses all the laser power on the retina, so focusing the eye directly on a laser source—even a low-power laser—could permanently damage the eye.

Avertissement Les connecteurs à fibre optique sans terminaison peuvent émettre un rayonnement laser invisible. Le cristallin de l'œil humain faisant converger toute la puissance du laser sur la rétine, toute focalisation directe de l'œil sur une source laser, — même de faible puissance—, peut entraîner des lésions oculaires irréversibles.

Class 1 Laser Product Warning



LASER WARNING: Class 1 laser product.

Waarschuwing Klasse-1 laser produkt.

Varoitus Luokan 1 lasertuote.

Avertissement Produit laser de classe I.

Warnung Laserprodukt der Klasse 1.

Avvertenza Prodotto laser di Classe 1.

Advarsel Laserprodukt av klasse 1.

Aviso Produto laser de classe 1.

¡Atención! Producto láser Clase I.

Varning! Laserprodukt av klass 1.

Class 1 LED Product Warning



LASER WARNING: Class 1 LED product.

Waarschuwing Klasse 1 LED-product.

Varoitus Luokan 1 valodiodituote.

Avertissement Alarme de produit LED Class I.

Warnung Class 1 LED-Produktwarnung.

Avvertenza Avvertenza prodotto LED di Classe 1.

Advarsel LED-produkt i klasse 1.

Aviso Produto de classe 1 com LED.

¡Atención! Aviso sobre producto LED de Clase 1.

Varning! Lysdiodprodukt av klass 1.

Laser Beam Warning



LASER WARNING: Do not stare into the laser beam or view it directly with optical instruments.

Waarschuwing Niet in de straal staren of hem rechtstreeks bekijken met optische instrumenten.

Varoitus Älä katso säteeseen äläkä tarkastele sitä suoraan optisen laitteen avulla.

Avertissement Ne pas fixer le faisceau des yeux, ni l'observer directement à l'aide d'instruments optiques.

Warnung Nicht direkt in den Strahl blicken und ihn nicht direkt mit optischen Geräten prüfen.

Avvertenza Non fissare il raggio con gli occhi né usare strumenti ottici per osservarlo direttamente.

Advarsel Stirr eller se ikke direkte p strlen med optiske instrumenter.

Aviso Não olhe fixamente para o raio, nem olhe para ele directamente com instrumentos ópticos.

¡Atención! No mirar fijamente el haz ni observarlo directamente con instrumentos ópticos.

Varning! Rikta inte blicken in mot strålen och titta inte direkt på den genom optiska instrument.

Maintenance and Operational Safety Guidelines and Warnings

IN THIS SECTION

- [Battery Handling Warning | 380](#)
- [Jewelry Removal Warning | 381](#)
- [Lightning Activity Warning | 383](#)
- [Operating Temperature Warning | 384](#)
- [Product Disposal Warning | 385](#)

While performing the maintenance activities for devices, observe the following guidelines and warnings:

Battery Handling Warning



WARNING: Replacing a battery incorrectly might result in an explosion. Replace a battery only with the same or equivalent type recommended by the manufacturer. Dispose of used batteries according to the manufacturer's instructions.

Waarschuwing Er is ontploffingsgevaar als de batterij verkeerd vervangen wordt. Vervang de batterij slechts met hetzelfde of een equivalent type dat door de fabrikant

aanbevolen is. Gebruikte batterijen dienen overeenkomstig fabrieksvoorschriften weggeworpen te worden.

Varoitus Räjähdyksen vaara, jos akku on vaihdettu väärään akkuun. Käytä vaihtamiseen ainoastaan saman- tai vastaavantyyppistä akkua, joka on valmistajan suosittama. Hävitä käytetyt akut valmistajan ohjeiden mukaan.

Avertissement Danger d'explosion si la pile n'est pas remplacée correctement. Ne la remplacer que par une pile de type semblable ou équivalent, recommandée par le fabricant. Jeter les piles usagées conformément aux instructions du fabricant.

Warnung Bei Einsetzen einer falschen Batterie besteht Explosionsgefahr. Ersetzen Sie die Batterie nur durch den gleichen oder vom Hersteller empfohlenen Batterietyp. Entsorgen Sie die benutzten Batterien nach den Anweisungen des Herstellers.

Advarsel Det kan være fare for eksplosjon hvis batteriet skiftes på feil måte. Skift kun med samme eller tilsvarende type som er anbefalt av produsenten. Kasser brukte batterier i henhold til produsentens instruksjoner.

Avvertenza Pericolo di esplosione se la batteria non è installata correttamente. Sostituire solo con una di tipo uguale o equivalente, consigliata dal produttore. Eliminare le batterie usate secondo le istruzioni del produttore.

Aviso Existe perigo de explosão se a bateria for substituída incorrectamente. Substitua a bateria por uma bateria igual ou de um tipo equivalente recomendado pelo fabricante. Destrua as baterias usadas conforme as instruções do fabricante.

¡Atención! Existe peligro de explosión si la batería se reemplaza de manera incorrecta. Reemplazar la batería EXclusivamente con el mismo tipo o el equivalente recomendado por el fabricante. Desechar las baterías gastadas según las instrucciones del fabricante.

Varning! Explosionsfara vid felaktigt batteribyte. Ersätt endast batteriet med samma batterityp som rekommenderas av tillverkaren eller motsvarande. Följ tillverkarens anvisningar vid kassering av använda batterier.

Jewelry Removal Warning



WARNING: Before working on equipment that is connected to power lines, remove jewelry, including rings, necklaces, and watches. Metal objects heat up when connected to power and ground and can cause serious burns or can be welded to the terminals.

Waarschuwing Alvorens aan apparatuur te werken die met elektrische leidingen is verbonden, sieraden (inclusief ringen, kettingen en horloges) verwijderen. Metalen voorwerpen worden warm wanneer ze met stroom en aarde zijn verbonden, en kunnen ernstige brandwonden veroorzaken of het metalen voorwerp aan de aansluitklemmen lassen.

Varoitus Ennen kuin työskentelet voimavirtajohtoihin kytkettyjen laitteiden parissa, ota pois kaikki korut (sormukset, kaulakorut ja kellot mukaan lukien). Metalliesineet kuumenevat, kun ne ovat yhteydessä sähkövirran ja maan kanssa, ja ne voivat aiheuttaa vakavia palovammoja tai hitsata metalliesineet kiinni liitännänapoihin.

Avertissement Avant d'accéder à cet équipement connecté aux lignes électriques, ôter tout bijou (anneaux, colliers et montres compris). Lorsqu'ils sont branchés à l'alimentation et reliés à la terre, les objets métalliques chauffent, ce qui peut provoquer des blessures graves ou souder l'objet métallique aux bornes.

Warnung Vor der Arbeit an Geräten, die an das Netz angeschlossen sind, jeglichen Schmuck (einschließlich Ringe, Ketten und Uhren) abnehmen. Metallgegenstände erhitzen sich, wenn sie an das Netz und die Erde angeschlossen werden, und können schwere Verbrennungen verursachen oder an die Anschlußklemmen angeschweißt werden.

Avvertenza Prima di intervenire su apparecchiature collegate alle linee di alimentazione, togliersi qualsiasi monile (inclusi anelli, collane, braccialetti ed orologi). Gli oggetti metallici si riscaldano quando sono collegati tra punti di alimentazione e massa: possono causare ustioni gravi oppure il metallo può saldarsi ai terminali.

Advarsel Fjern alle smykker (inkludert ringer, halskjeder og klokker) før du skal arbeide på utstyr som er koblet til kraftledninger. Metallgjenstander som er koblet til kraftledninger og jord blir svært varme og kan forårsake alvorlige brannskader eller smelte fast til polene.

Aviso Antes de trabalhar em equipamento que esteja ligado a linhas de corrente, retire todas as jóias que estiver a usar (incluindo anéis, fios e relógios). Os objectos metálicos aquecerão em contacto com a corrente e em contacto com a ligação à terra, podendo causar queimaduras graves ou ficarem soldados aos terminais.

¡Atención! Antes de operar sobre equipos conectados a líneas de alimentación, quitarse las joyas (incluidos anillos, collares y relojes). Los objetos de metal se calientan cuando se conectan a la alimentación y a tierra, lo que puede ocasionar quemaduras graves o que los objetos metálicos queden soldados a los bornes.

Warning! Tag av alla smycken (inklusive ringar, halsband och armbandsur) innan du arbetar på utrustning som är kopplad till kraftledning. Metallobjekt hettas upp när de kopplas ihop med ström och jord och kan förorsaka allvarliga brännskador; metallobjekt kan också sammansvetsas med kontakterna.

Lightning Activity Warning



WARNING: Do not work on the system or connect or disconnect cables during periods of lightning activity.

Waarschuwing Tijdens onweer dat gepaard gaat met bliksem, dient u niet aan het systeem te werken of kabels aan te sluiten of te ontkoppelen.

Varoitus Älä työskentele järjestelmän parissa äläkä yhdistä tai irrota kaapeleita ukkosilmalla.

Avertissement Ne pas travailler sur le système ni brancher ou débrancher les câbles pendant un orage.

Warnung Arbeiten Sie nicht am System und schließen Sie keine Kabel an bzw. trennen Sie keine ab, wenn es gewittert.

Avvertenza Non lavorare sul sistema o collegare oppure scollegare i cavi durante un temporale con fulmini.

Advarsel Utfør aldri arbeid på systemet, eller koble kabler til eller fra systemet når det tordner eller lyner.

Aviso Não trabalhe no sistema ou ligue e desligue cabos durante períodos de mau tempo (trovoada).

¡Atención! No operar el sistema ni conectar o desconectar cables durante el transcurso de descargas eléctricas en la atmósfera.

Warning! Vid åska skall du aldrig utföra arbete på systemet eller ansluta eller koppla loss kablar.

Operating Temperature Warning



WARNING: To prevent the device from overheating, do not operate it in an area that exceeds the maximum recommended ambient temperature. To prevent airflow restriction, allow at least 6 in. (15.2 cm) of clearance around the ventilation openings.

Waarschuwing Om te voorkomen dat welke switch van de Juniper Networks router dan ook oververhit raakt, dient u deze niet te bedienen op een plaats waar de maximale aanbevolen omgevingstemperatuur van 40° C wordt overschreden. Om te voorkomen dat de luchtstroom wordt beperkt, dient er minstens 15,2 cm speling rond de ventilatie-openingen te zijn.

Varoitus Ettei Juniper Networks switch-sarjan reititin ylikuumentuisi, sitä ei saa käyttää tilassa, jonka lämpötila ylittää korkeimman suositellun ympäristölämpötilan 40° C. Ettei ilmanvaihto estyisi, tuuletusaukkojen ympärille on jätettävä ainakin 15,2 cm tilaa.

Avertissement Pour éviter toute surchauffe des routeurs de la gamme Juniper Networks switch, ne l'utilisez pas dans une zone où la température ambiante est supérieure à 40° C. Pour permettre un flot d'air constant, dégagez un espace d'au moins 15,2 cm autour des ouvertures de ventilations.

Warnung Um einen Router der switch vor Überhitzung zu schützen, darf dieser nicht in einer Gegend betrieben werden, in der die Umgebungstemperatur das empfohlene Maximum von 40° C überschreitet. Um Lüftungsverschluß zu verhindern, achten Sie darauf, daß mindestens 15,2 cm lichter Raum um die Lüftungsöffnungen herum frei bleibt.

Avvertenza Per evitare il surriscaldamento dei switch, non adoperateli in un locale che ecceda la temperatura ambientale massima di 40° C. Per evitare che la circolazione dell'aria sia impedita, lasciate uno spazio di almeno 15.2 cm di fronte alle aperture delle ventole.

Advarsel Unngå overoppheting av eventuelle rutere i Juniper Networks switch Disse skal ikke brukes på steder der den anbefalte maksimale omgivelsestemperaturen overstiger 40° C (104° F). Sørg for at klaringen rundt lufteåpningene er minst 15,2 cm (6 tommer) for å forhindre nedsatt luftsirkulasjon.

Aviso Para evitar o sobreaquecimento do encaminhador Juniper Networks switch, não utilize este equipamento numa área que exceda a temperatura máxima recomendada de 40° C. Para evitar a restrição à circulação de ar, deixe pelo menos um espaço de 15,2 cm à volta das aberturas de ventilação.

¡Atención! Para impedir que un encaminador de la serie Juniper Networks switch se recaliente, no lo haga funcionar en un área en la que se supere la temperatura ambiente máxima recomendada de 40° C. Para impedir la restricción de la entrada de aire, deje un espacio mínimo de 15,2 cm alrededor de las aperturas para ventilación.

Varning! Förhindra att en Juniper Networks switch överhettas genom att inte använda den i ett område där den maximalt rekommenderade omgivningstemperaturen på 40° C överskrids. Förhindra att luftcirkulationen inskränks genom att se till att det finns fritt utrymme på minst 15,2 cm omkring ventilationsöppningarna.

Product Disposal Warning



WARNING: Disposal of this device must be handled according to all national laws and regulations.

Waarschuwing Dit produkt dient volgens alle landelijke wetten en voorschriften te worden afgedankt.

Varoitus Tämän tuotteen lopullisesta hävittämisestä tulee huolehtia kaikkia valtakunnallisia lakeja ja säännöksiä noudattaen.

Avertissement La mise au rebut définitive de ce produit doit être effectuée conformément à toutes les lois et réglementations en vigueur.

Warnung Dieses Produkt muß den geltenden Gesetzen und Vorschriften entsprechend entsorgt werden.

Avvertenza L'eliminazione finale di questo prodotto deve essere eseguita osservando le normative italiane vigenti in materia

Advarsel Endelig disponering av dette produktet må skje i henhold til nasjonale lover og forskrifter.

Aviso A descartagem final deste produto deverá ser efectuada de acordo com os regulamentos e a legislação nacional.

¡Atención! El desecho final de este producto debe realizarse según todas las leyes y regulaciones nacionales

Varning! Slutlig kassering av denna produkt bör skötas i enlighet med landets alla lagar och föreskrifter.

General Electrical Safety Guidelines and Warnings



WARNING: Certain ports on the device are designed for use as intrabuilding (within-the-building) interfaces only (Type 2 or Type 4 ports as described in *GR-1089-CORE*) and require isolation from the exposed outside plant (OSP) cabling. To comply with NEBS requirements and protect against lightning surges and commercial power disturbances, the intrabuilding ports *must not* be metallicity connected to interfaces that connect to the OSP or its wiring. The intrabuilding ports on the device are suitable for connection to intrabuilding or unexposed wiring or cabling only. The addition of primary protectors is not sufficient protection for connecting these interfaces metallicity to OSP wiring.

Avertissement Certains ports de l'appareil sont destinés à un usage en intérieur uniquement (ports Type 2 ou Type 4 tels que décrits dans le document *GR-1089-CORE*) et doivent être isolés du câblage de l'installation extérieure exposée. Pour respecter les exigences NEBS et assurer une protection contre la foudre et les perturbations de tension secteur, les ports pour intérieur *ne doivent pas* être raccordés physiquement aux interfaces prévues pour la connexion à l'installation extérieure ou à son câblage. Les ports pour intérieur de l'appareil sont réservés au raccordement de câbles pour intérieur ou non exposés uniquement. L'ajout de protections ne constitue pas une précaution suffisante pour raccorder physiquement ces interfaces au câblage de l'installation extérieure.



CAUTION: Before removing or installing components of a device, connect an electrostatic discharge (ESD) grounding strap to an ESD point and wrap and fasten the other end of the strap around your bare wrist. Failure to use an ESD grounding strap could result in damage to the device.

Attention Avant de retirer ou d'installer des composants d'un appareil, raccordez un bracelet antistatique à un point de décharge électrostatique et fixez le bracelet à votre poignet nu. L'absence de port d'un bracelet antistatique pourrait provoquer des dégâts sur l'appareil.

- Install the device in compliance with the following local, national, and international electrical codes:
 - United States—National Fire Protection Association (NFPA 70), United States National Electrical Code.
 - Other countries—International Electromechanical Commission (IEC) 60364, Part 1 through Part 7.
 - Evaluated to the TN power system.

- Canada—Canadian Electrical Code, Part 1, CSA C22.1.
- Suitable for installation in Information Technology Rooms in accordance with Article 645 of the National Electrical Code and NFPA 75.

Peut être installé dans des salles de matériel de traitement de l'information conformément à l'article 645 du National Electrical Code et à la NFPA 75.

- Locate the emergency power-off switch for the room in which you are working so that if an electrical accident occurs, you can quickly turn off the power.
- Make sure that grounding surfaces are cleaned and brought to a bright finish before grounding connections are made.
- Do not work alone if potentially hazardous conditions exist anywhere in your workspace.
- Never assume that power is disconnected from a circuit. Always check the circuit before starting to work.
- Carefully look for possible hazards in your work area, such as moist floors, ungrounded power extension cords, and missing safety grounds.
- Operate the device within marked electrical ratings and product usage instructions.
- To ensure that the device and peripheral equipment function safely and correctly, use the cables and connectors specified for the attached peripheral equipment, and make certain they are in good condition.

You can remove and replace many device components without powering off or disconnecting power to the device, as detailed elsewhere in the hardware documentation for this device. Never install equipment that appears to be damaged.

Action to Take After an Electrical Accident

If an electrical accident results in an injury, take the following actions in this order:

1. Use caution. Be aware of potentially hazardous conditions that could cause further injury.
2. Disconnect power from the device.
3. If possible, send another person to get medical aid. Otherwise, assess the condition of the victim, then call for help.

Prevention of Electrostatic Discharge Damage

Device components that are shipped in antistatic bags are sensitive to damage from static electricity. Some components can be impaired by voltages as low as 30 V. You can easily generate potentially damaging static voltages whenever you handle plastic or foam packing material or if you move components across plastic or carpets. Observe the following guidelines to minimize the potential for electrostatic discharge (ESD) damage, which can cause intermittent or complete component failures:

- Always use an ESD wrist strap when you are handling components that are subject to ESD damage, and make sure that it is in direct contact with your skin.

If a grounding strap is not available, hold the component in its antistatic bag (see [Figure 180 on page 389](#)) in one hand and touch the exposed, bare metal of the device with the other hand immediately before inserting the component into the device.



WARNING: For safety, periodically check the resistance value of the ESD grounding strap. The measurement must be in the range 1 through 10 Mohms.

Avertissement Par mesure de sécurité, vérifiez régulièrement la résistance du bracelet antistatique. Cette valeur doit être comprise entre 1 et 10 mégohms (Mohms).

- When handling any component that is subject to ESD damage and that is removed from the device, make sure the equipment end of your ESD wrist strap is attached to the ESD point on the chassis.

If no grounding strap is available, touch the exposed, bare metal of the device to ground yourself before handling the component.

- Avoid contact between the component that is subject to ESD damage and your clothing. ESD voltages emitted from clothing can damage components.

- When removing or installing a component that is subject to ESD damage, always place it component-side up on an antistatic surface, in an antistatic card rack, or in an antistatic bag (see [Figure 180 on page 389](#)). If you are returning a component, place it in an antistatic bag before packing it.

Figure 180: Placing a Component into an Antistatic Bag

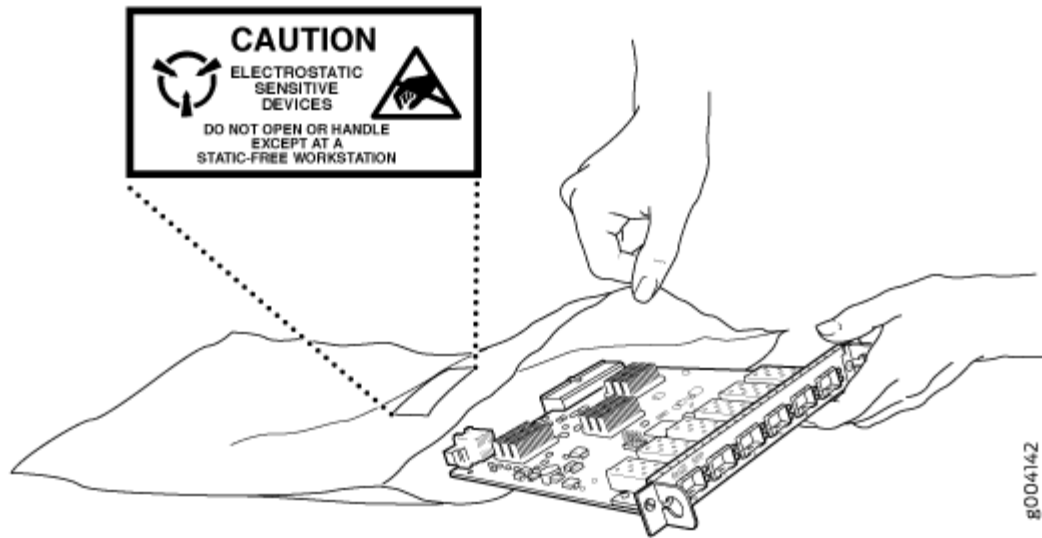

CAUTION: ANSI/TIA/EIA-568 cables such as Category 5e and Category 6 can get electrostatically charged. To dissipate this charge, always ground the cables to a suitable and safe earth ground before connecting them to the system.

Attention Les câbles ANSI/TIA/EIA-568, par exemple Cat 5e et Cat 6, peuvent emmagasiner des charges électrostatiques. Pour évacuer ces charges, reliez toujours les câbles à une prise de terre adaptée avant de les raccorder au système.

AC Power Electrical Safety Guidelines

The following electrical safety guidelines apply to AC-powered devices:

- Note the following warnings printed on the device:

“CAUTION: THIS UNIT HAS MORE THAN ONE POWER SUPPLY CORD. DISCONNECT ALL POWER SUPPLY CORDS BEFORE SERVICING TO AVOID ELECTRIC SHOCK.”

“**ATTENTION:** CET APPAREIL COMPORTE PLUS D'UN CORDON D'ALIMENTATION. AFIN DE PRÉVENIR LES CHOCS ÉLECTRIQUES, DÉBRANCHER TOUT CORDON D'ALIMENTATION AVANT DE FAIRE LE DÉPANNAGE.”

- AC-powered devices are shipped with a three-wire electrical cord with a grounding-type plug that fits only a grounding-type power outlet. Do not circumvent this safety feature. Equipment grounding must comply with local and national electrical codes.
- You must provide an external certified circuit breaker (2-pole circuit breaker or 4-pole circuit breaker based on your device) rated minimum 20 A in the building installation.
- The power cord serves as the main disconnecting device for the AC-powered device. The socket outlet must be near the AC-powered device and be easily accessible.
- For devices that have more than one power supply connection, you must ensure that all power connections are fully disconnected so that power to the device is completely removed to prevent electric shock. To disconnect power, unplug all power cords (one for each power supply).

Power Cable Warning (Japanese)

WARNING: The attached power cable is only for this product. Do not use the cable for another product.

注意

附属の電源コードセットはこの製品専用です。
他の電気機器には使用しないでください。

947738A

AC Power Disconnection Warning



WARNING: Before working on the device or near power supplies, unplug all the power cords from an AC-powered device.

Waarschuwing Voordat u aan een frame of in de nabijheid van voedingen werkt, dient u bij wisselstroom toestellen de stekker van het netsnoer uit het stopcontact te halen.

Varoitus Kytke irti vaihtovirtalaitteiden virtajohto, ennen kuin teet mitään asennuspohjalle tai työskentelet virtalähteiden läheisyydessä.

Avertissement Avant de travailler sur un châssis ou à proximité d'une alimentation électrique, débrancher le cordon d'alimentation des unités en courant alternatif.

Warnung Bevor Sie an einem Chassis oder in der Nähe von Netzgeräten arbeiten, ziehen Sie bei Wechselstromeinheiten das Netzkabel ab bzw.

Avvertenza Prima di lavorare su un telaio o intorno ad alimentatori, scollegare il cavo di alimentazione sulle unità CA.

Advarsel Før det utføres arbeid på kabinettet eller det arbeides i nærheten av strømforsyningsenheter, skal strømledningen trekkes ut på vekselstrømsenheter.

Aviso Antes de trabalhar num chassis, ou antes de trabalhar perto de unidades de fornecimento de energia, desligue o cabo de alimentação nas unidades de corrente alternada.

¡Atención! Antes de manipular el chasis de un equipo o trabajar cerca de una fuente de alimentación, desenchufar el cable de alimentación en los equipos de corriente alterna (CA).

Warning! Innan du arbetar med ett chassi eller nära strömförsörjningsenheter skall du för växelströmsenheter dra ur nätsladden.

DC Power Electrical Safety Guidelines for PTX10008 and PTX10016 Routers

This topic applies to hardware devices in the PTX10008 and PTX10016 routers.

- A DC-powered device is equipped with a DC terminal block that is rated for the power requirements of a maximally configured device.

NOTE: To supply sufficient power, terminate the DC input wiring on a facility DC source that is capable of supplying:

- Minimum of 60 A at -48 VDC for PTX10008 routers and PTX10016 routers

Incorporate an easily accessible disconnect device into the facility wiring. Be sure to connect the ground wire or conduit to a solid office earth ground. A closed loop ring is recommended for terminating the ground conductor at the ground stud.

- Run two wires from the circuit breaker box to a source of 48 VDC.
- A DC-powered device that is equipped with a DC terminal block is intended only for installation in a restricted-access location. In the United States, a restricted-access area is one in accordance with Articles 110-16, 110-17, and 110-18 of the National Electrical Code ANSI/NFPA 70.

NOTE: Primary overcurrent protection is provided by the building circuit breaker. This breaker must protect against excess currents, short circuits, and earth grounding faults in accordance with NEC ANSI/NFPA 70.

- Ensure that the polarity of the DC input wiring is correct. Under certain conditions, connections with reversed polarity might trip the primary circuit breaker or damage the equipment.
- For personal safety, connect the green and yellow wire to safety (earth) ground at both the device and the supply side of the DC wiring.
- The marked input voltage of -48 VDC for a DC-powered device is the nominal voltage associated with the battery circuit, and any higher voltages are only to be associated with float voltages for the charging function.
- Because the device is a positive ground system, you must connect the positive lead to the terminal labeled **RTN**, the negative lead to the terminal labeled -48 VDC, and the earth ground to the device grounding points.

DC Power Copper Conductors Warning



WARNING: Use copper conductors only.

Waarschuwing Gebruik alleen koperen geleiders.

Varoitus Käytä vain kuparijohtimia.

Attention Utilisez uniquement des conducteurs en cuivre.

Warnung Verwenden Sie ausschließlich Kupferleiter.

Avvertenza Usate unicamente dei conduttori di rame.

Advarsel Bruk bare kobberledninger.

Aviso Utilize apenas fios condutores de cobre.

¡Atención! Emplee sólo conductores de cobre.

Varning! Använd endast ledare av koppar.

DC Power Disconnection Warning



WARNING: Before performing any of the DC power procedures, ensure that power is removed from the DC circuit. To ensure that all power is off, locate the circuit breaker on the panel board that services the DC circuit, switch the circuit breaker to the OFF position, and tape the device handle of the circuit breaker in the OFF position.

Waarschuwing Voordat u een van de onderstaande procedures uitvoert, dient u te controleren of de stroom naar het gelijkstroom circuit uitgeschakeld is. Om u ervan te verzekeren dat alle stroom UIT is geschakeld, kiest u op het schakelbord de stroomverbreker die het gelijkstroom circuit bedient, draait de stroomverbreker naar de UIT positie en plakt de schakelaarhendel van de stroomverbreker met plakband in de UIT positie vast.

Varoitus Varmista, että tasavirtapiirissä ei ole virtaa ennen seuraavien toimenpiteiden suorittamista. Varmistaaksesi, että virta on KATKAISTU täysin, paikanna tasavirrasta huolehtivassa kojetaulussa sijaitseva suojakytkin, käännä suojakytkin KATKAISTU-asentoon ja teippaa suojakytkimen varsi niin, että se pysyy KATKAISTU-asennossa.

Avertissement Avant de pratiquer l'une quelconque des procédures ci-dessous, vérifier que le circuit en courant continu n'est plus sous tension. Pour en être sûr, localiser le disjoncteur situé sur le panneau de service du circuit en courant continu, placer le disjoncteur en position fermée (OFF) et, à l'aide d'un ruban adhésif, bloquer la poignée du disjoncteur en position OFF.

Warnung Vor Ausführung der folgenden Vorgänge ist sicherzustellen, daß die Gleichstromschaltung keinen Strom erhält. Um sicherzustellen, daß sämtlicher Strom abgestellt ist, machen Sie auf der Schalttafel den Unterbrecher für die Gleichstromschaltung ausfindig, stellen Sie den Unterbrecher auf AUS, und kleben Sie den Schaltergriff des Unterbrechers mit Klebeband in der AUS-Stellung fest.

Avvertenza Prima di svolgere una qualsiasi delle procedure seguenti, verificare che il circuito CC non sia alimentato. Per verificare che tutta l'alimentazione sia scollegata (OFF), individuare l'interruttore automatico sul quadro strumenti che alimenta il circuito CC, mettere l'interruttore in posizione OFF e fissarlo con nastro adesivo in tale posizione.

Advarsel Før noen av disse prosedyrene utføres, kontroller at strømmen er frakoblet likestrømkretsen. Sørg for at all strøm er slått AV. Dette gjøres ved å lokalisere strømbryteren på brytertavlen som betjener likestrømkretsen, slå strømbryteren AV og teipe bryterhåndtaket på strømbryteren i AV-stilling.

Aviso Antes de executar um dos seguintes procedimentos, certifique-se que desligou a fonte de alimentação de energia do circuito de corrente contínua. Para se assegurar que toda a corrente foi DESLIGADA, localize o disjuntor no painel que serve o circuito de corrente contínua e coloque-o na posição OFF (Desligado), segurando nessa posição a manivela do interruptor do disjuntor com fita isoladora.

¡Atención! Antes de proceder con los siguientes pasos, comprobar que la alimentación del circuito de corriente continua (CC) esté cortada (OFF). Para asegurarse de que toda la alimentación esté cortada (OFF), localizar el interruptor automático en el panel que alimenta al circuito de corriente continua, cambiar el interruptor automático a la posición de Apagado (OFF), y sujetar con cinta la palanca del interruptor automático en posición de Apagado (OFF).

Varning! Innan du utför någon av följande procedurer måste du kontrollera att strömförsörjningen till likströmskretsen är bruten. Kontrollera att all strömförsörjning är BRUTEN genom att slå AV det överspänningsskydd som skyddar likströmskretsen och tejpa fast överspänningsskyddets omkopplare i FRÅN-läget.

DC Power Grounding Requirements and Warning

An insulated grounding conductor that is identical in size to the grounded and ungrounded branch circuit supply conductors but is identifiable by green and yellow stripes is installed as part of the branch circuit that supplies the device. The grounding conductor is a separately derived system at the supply transformer or motor generator set.



WARNING: When you install the device, the ground connection must always be made first and disconnected last.

Waarschuwing Bij de installatie van het toestel moet de aardverbinding altijd het eerste worden gemaakt en het laatste worden losgemaakt.

Varoitus Laitetta asennettaessa on maahan yhdistäminen aina tehtävä ensiksi ja maadoituksen irti kytkeminen viimeiseksi.

Avertissement Lors de l'installation de l'appareil, la mise à la terre doit toujours être connectée en premier et déconnectée en dernier.

Warnung Der Erdanschluß muß bei der Installation der Einheit immer zuerst hergestellt und zuletzt abgetrennt werden.

Avvertenza In fase di installazione dell'unità, eseguire sempre per primo il collegamento a massa e disconnetterlo per ultimo.

Advarsel Når enheten installeres, må jordledningen alltid tilkobles først og frakobles sist.

Aviso Ao instalar a unidade, a ligação à terra deverá ser sempre a primeira a ser ligada, e a última a ser desligada.

¡Atención! Al instalar el equipo, conectar la tierra la primera y desconectarla la última.

Varning! Vid installation av enheten måste jordledningen alltid anslutas först och kopplas bort sist.

DC Power Wiring Sequence Warning



WARNING: Wire the DC power supply using the appropriate lugs. When connecting power, the proper wiring sequence is ground to ground, +RTN to +RTN, then -48 V to -48 V. When disconnecting power, the proper wiring sequence is -48 V to -48 V, +RTN to +RTN, then ground to ground. Note that the ground wire must always be connected first and disconnected last.

Waarschuwing De juiste bedradingsvolgorde verbonden is aarde naar aarde, +RTN naar +RTN, en -48 V naar -48 V. De juiste bedradingsvolgorde losgemaakt is en -48 naar -48 V, +RTN naar +RTN, aarde naar aarde.

Varoitus Oikea yhdistettävä kytkentäjärjestys on maajohto maajohtoon, +RTN varten +RTN, -48 V varten -48 V. Oikea irrotettava kytkentäjärjestys on -48 V varten -48 V, +RTN varten +RTN, maajohto maajohtoon.

Avertissement Câblez l'alimentation d'alimentation CC En utilisant les crochets appropriés à l'extrémité de câblage. En reliant la puissance, l'ordre approprié de câblage est rectifié pour rectifier, +RTN à +RTN, puis -48 V à -48 V. En débranchant la puissance, l'ordre approprié de câblage est -48 V à -48 V, +RTN à +RTN, a alors rectifié pour rectifier. Notez que le fil de masse devrait toujours être relié d'abord et débranché pour la dernière fois. Notez que le fil de masse devrait toujours être relié d'abord et débranché pour la dernière fois.

Warnung Die Stromzufuhr ist nur mit geeigneten Ringösen an das DC Netzteil anzuschliessen. Die richtige Anschlusssequenz ist: Erdanschluss zu Erdanschluss, +RTN zu +RTN und dann -48V zu -48V. Die richtige Sequenz zum Abtrennen der Stromversorgung ist -48V zu -48V, +RTN zu +RTN und dann Erdanschluss zu Erdanschluss. Es ist zu beachten dass der Erdanschluss immer zuerst angeschlossen und als letztes abgetrennt wird.

Avvertenza Mostra la morsettiera dell alimentatore CC. Cablare l'alimentatore CC usando i connettori adatti all'estremità del cablaggio, come illustrato. La corretta sequenza di cablaggio è da massa a massa, da positivo a positivo (da linea ad L) e da negativo a negativo (da neutro a N). Tenere presente che il filo di massa deve sempre venire collegato per primo e scollegato per ultimo.

Advarsel Riktig tilkoples tilkoplingssekvens er jord til jord, +RTN til +RTN, -48 V til -48 V. Riktig frakoples tilkoplingssekvens er -48 V til -48 V, +RTN til +RTN, jord til jord.

Aviso Ate con alambre la fuente de potencia cc Usando los terminales apropiados en el extremo del cableado. Al conectar potencia, la secuencia apropiada del cableado se muele para moler, +RTN a +RTN, entonces -48 V a -48 V. Al desconectar potencia, la secuencia apropiada del cableado es -48 V a -48 V, +RTN a +RTN, entonces molió para moler. Observe que el alambre de tierra se debe conectar siempre primero y desconectar por último. Observe que el alambre de tierra se debe conectar siempre primero y desconectar por último.

¡Atención! Wire a fonte de alimentação de DC Usando os talões apropriados nan Extremidade da fiação. Ao conectar a potência, a seqüência apropriada da fiação é moída para moer, +RTN a +RTN, então -48 V a -48 V. Ao desconectar a potência, a seqüência apropriada da fiação é -48 V a -48 V, +RTN a +RTN, moeu então para moer. Anote que o fio à terra deve sempre ser conectado primeiramente e desconectado por último. Anote que o fio à terra deve sempre ser conectado primeiramente e desconectado por último.

Varning! Korrekt kopplingssekvens ar jord till jord, +RTN till +RTN, -48 V till -48 V. Korrekt kopplas kopplingssekvens ar -48 V till -48 V, +RTN till +RTN, jord till jord.

DC Power Wiring Terminations Warning



WARNING: When stranded wiring is required, use approved wiring terminations, such as closed-loop or spade-type with upturned lugs. These terminations must be the appropriate size for the wires and must clamp both the insulation and conductor.

Waarschuwing Wanneer geslagen bedrading vereist is, dient u bedrading te gebruiken die voorzien is van goedgekeurde aansluitpunten, zoals het gesloten-lus type of het grijperschop type waarbij de aansluitpunten omhoog wijzen. Deze aansluitpunten dienen de juiste maat voor de draden te hebben en dienen zowel de isolatie als de geleider vast te klemmen.

Varoitus Jos säikeellinen johdin on tarpeen, käytä hyväksyttyä johdinliitääntä, esimerkiksi suljettua silmukkaa tai kourumaista liitääntä, jossa on ylöspäin käännetyt kiinnityskorvat. Tällaisten liitääntöjen tulee olla kooltaan johtimiin sopivia ja niiden tulee puristaa yhteen sekä eristeen että johdinosan.

Avertissement Quand des fils torsadés sont nécessaires, utiliser des douilles terminales homologuées telles que celles à circuit fermé ou du type à plage ouverte avec cosses rebroussées. Ces douilles terminales doivent être de la taille qui convient aux fils et doivent être refermées sur la gaine isolante et sur le conducteur.

Warnung Wenn Litzenverdrahtung erforderlich ist, sind zugelassene Verdrahtungsabschlüsse, z.B. für einen geschlossenen Regelkreis oder gabelförmig, mit nach oben gerichteten Kabelschuhen zu verwenden. Diese Abschlüsse sollten die angemessene Größe für die Drähte haben und sowohl die Isolierung als auch den Leiter festklemmen.

Avvertenza Quando occorre usare trecce, usare connettori omologati, come quelli a occhiello o a forcilla con linguette rivolte verso l'alto. I connettori devono avere la misura adatta per il cablaggio e devono serrare sia l'isolante che il conduttore.

Advarsel Hvis det er nødvendig med flertrådede ledninger, brukes godkjente ledningsavslutninger, som for eksempel lukket sløyfe eller spadetype med oppoverbøyde kabelsko. Disse avslutningene skal ha riktig størrelse i forhold til ledningene, og skal klemme sammen både isolasjonen og ledere.

Aviso Quando forem requeridas montagens de instalação eléctrica de cabo torcido, use terminações de cabo aprovadas, tais como, terminações de cabo em circuito fechado e planas com terminais de orelha voltados para cima. Estas terminações de cabo deverão ser do tamanho apropriado para os respectivos cabos, e deverão prender simultaneamente o isolamento e o fio condutor.

¡Atención! Cuando se necesite hilo trenzado, utilizar terminales para cables homologados, tales como las de tipo "bucle cerrado" o "espada", con las lengüetas de conexión vueltas hacia arriba. Estos terminales deberán ser del tamaño apropiado para los cables que se utilicen, y tendrán que sujetar tanto el aislante como el conductor.

Varning! När flertrådiga ledningar krävs måste godkända ledningskontakter användas, t.ex. kabelsko av slutet eller öppen typ med uppåtvänd tapp. Storleken på dessa kontakter måste vara avpassad till ledningarna och måste kunna hålla både isoleringen och ledaren fastklämda.

Multiple Power Supplies Disconnection Warning



WARNING: The network device has more than one power supply connection. All connections must be removed completely to remove power from the unit completely.

Waarschuwing Deze eenheid heeft meer dan één stroomtoevoerverbinding; alle verbindingen moeten volledig worden verwijderd om de stroom van deze eenheid volledig te verwijderen.

Varoitus Tässä laitteessa on useampia virtalähdekytkentöjä. Kaikki kytkennät on irrotettava kokonaan, jotta virta poistettaisiin täysin laitteesta.

Avertissement Cette unité est équipée de plusieurs raccordements d'alimentation. Pour supprimer tout courant électrique de l'unité, tous les cordons d'alimentation doivent être débranchés.

Warnung Diese Einheit verfügt über mehr als einen Stromanschluß; um Strom gänzlich von der Einheit fernzuhalten, müssen alle Stromzufuhren abgetrennt sein.

Avvertenza Questa unità ha più di una connessione per alimentatore elettrico; tutte le connessioni devono essere completamente rimosse per togliere l'elettricità dall'unità.

Advarsel Denne enheten har mer enn én strømtilkobling. Alle tilkoblinger må kobles helt fra for å eliminere strøm fra enheten.

Aviso Este dispositivo possui mais do que uma conexão de fonte de alimentação de energia; para poder remover a fonte de alimentação de energia, deverão ser desconectadas todas as conexões existentes.

¡Atención! Esta unidad tiene más de una conexión de suministros de alimentación; para eliminar la alimentación por completo, deben desconectarse completamente todas las conexiones.

Varning! Denna enhet har mer än en strömförsörjningsanslutning; alla anslutningar måste vara helt avlägsnade innan strömtillförseln till enheten är fullständigt bruten.

TN Power Warning



WARNING: The device is designed to work with a TN power system.

Waarschuwing Het apparaat is ontworpen om te functioneren met TN energiesystemen.

Varoitus Koje on suunniteltu toimimaan TN-sähkövoimajärjestelmien yhteydessä.

Avertissement Ce dispositif a été conçu pour fonctionner avec des systèmes d'alimentation TN.

Warnung Das Gerät ist für die Verwendung mit TN-Stromsystemen ausgelegt.

Avvertenza Il dispositivo è stato progettato per l'uso con sistemi di alimentazione TN.

Advarsel Utstyret er utfomet til bruk med TN-strømsystemer.

Aviso O dispositivo foi criado para operar com sistemas de corrente TN.

¡Atención! El equipo está diseñado para trabajar con sistemas de alimentación tipo TN.

Varning! Enheten är konstruerad för användning tillsammans med elkraftssystem av TN-typ.

Fire Safety Requirements

IN THIS SECTION

- [Fire Suppression | 400](#)
- [Fire Suppression Equipment | 400](#)

In the event of a fire emergency, the safety of people is the primary concern. You should establish procedures for protecting people in the event of a fire emergency, provide safety training, and properly provision fire-control equipment and fire extinguishers.

In addition, you should establish procedures to protect your equipment in the event of a fire emergency. Juniper Networks products should be installed in an environment suitable for electronic equipment. We recommend that fire suppression equipment be available in the event of a fire in the vicinity of the equipment and that all local fire, safety, and electrical codes and ordinances be observed when you install and operate your equipment.

Fire Suppression

In the event of an electrical hazard or an electrical fire, you should first turn power off to the equipment at the source. Then use a Type C fire extinguisher, which uses noncorrosive fire retardants, to extinguish the fire.

Fire Suppression Equipment

Type C fire extinguishers, which use noncorrosive fire retardants such as carbon dioxide and Halotron™, are most effective for suppressing electrical fires. Type C fire extinguishers displace oxygen from the point of combustion to eliminate the fire. For extinguishing fire on or around equipment that draws air from the environment for cooling, you should use this type of inert oxygen displacement extinguisher instead of an extinguisher that leaves residues on equipment.

Do not use multipurpose Type ABC chemical fire extinguishers (dry chemical fire extinguishers). The primary ingredient in these fire extinguishers is monoammonium phosphate, which is very sticky and

difficult to clean. In addition, in the presence of minute amounts of moisture, monoammonium phosphate can become highly corrosive and corrodes most metals.

Any equipment in a room in which a chemical fire extinguisher has been discharged is subject to premature failure and unreliable operation. The equipment is considered to be irreparably damaged.

NOTE: To keep warranties effective, do not use a dry chemical fire extinguisher to control a fire at or near a Juniper Networks device. If a dry chemical fire extinguisher is used, the unit is no longer eligible for coverage under a service agreement.

We recommend that you dispose of any irreparably damaged equipment in an environmentally responsible manner.

PTX10008 and PTX10016 Agency Approvals and Compliance Statements

IN THIS SECTION

- [Agency Approvals for the PTX10008 and PTX10016 Routers | 401](#)
- [Compliance Statements for EMC Requirements for the PTX10008 and PTX10016 Routers | 403](#)

Agency Approvals for the PTX10008 and PTX10016 Routers

The PTX Series routers are tested against these standards:

- Safety
 - UL 62368-1 Standard for Audio/video, information and communication technology equipment - Part 1: Safety requirements
 - CAN/CSA-C22.2 No. 60950-1 Information Technology Equipment - Safety
 - IEC 62368-1 Information Technology Equipment - Safety
 - IEC 60950-1 Information Technology Equipment - Safety CB Scheme report

- IEC 60825-1 Laser safety
-
- EMC
 - FCC 47 CFR, Part 15 Class A (2012) USA radiated emissions – Class A
 - IC ICES-003 Issue 6, Jan 2016 Canada radiated emissions – Class A
 - EN 300 386 V1.6.1 Telecom network equipment - EMC requirements Class A
 - EN 300 386 V2.1.1 Telecom network equipment - EMC requirements Class A
 - EN 55032:2012 + EN55032:2012/AC:2013 Electromagnetic compatibility of multimedia equipment - Emission requirements Class A
 - CISPR 32:2012 Electromagnetic compatibility of multimedia equipment - Emission Requirements Class A
 - EN 55024:2010/AC:2011 European radiated emissions Class A
 - CISPR 24 Information technology equipment - Immunity testing
 - EN 55035:2017 – Electromagnetic compatibility of multimedia equipment – Immunity requirements
 - CISPR 35:2016 – Electromagnetic compatibility of multimedia equipment – Immunity requirements
 - IEC/EN 61000 Series – Electromagnetic compatibility
 - AS/NZS CISPR 32:2015 Electromagnetic compatibility of multimedia equipment - Emission requirements Class A
 - VCCI-CISPR 32:2016 Japanese radiated and conducted emissions Class A
 - BSMI CNS 13438 – Taiwan radiated emissions Class A
 - KN32 and KN35 – Korea radiated emission (at 10 Meter) Class A
 - KN 61000 Series – Korea electromagnetic compatibility
 - TEC/SD/DD/EMC-221/05/Oct-16 – Electromagnetic compatibility
 - VCCI-V-3/2013.04 and V-4/2012.04 – Japanese radiated emissions Class A
 - TCVN 7189 – Vietnam Electromagnetic compatibility for Multimedia
 - TCVN 7317:2003 – Vietnam Electromagnetic compatibility for Multimedia

- Network Equipment Building System (NEBS)
 - EN 300 019-2-1 – Environmental engineering
 - EN 300 019-2-2 – Equipment engineering
 - EN 300 019-2-3 – Environmental engineering
 - EN 300 753 – Equipment engineering
 - GR-63-CORE – Requirements, physical protection
 - GR-1089-CORE, Issue 7 – Acoustic noise

Compliance Statements for EMC Requirements for the PTX10008 and PTX10016 Routers

IN THIS SECTION

- [Canada | 403](#)
- [European Community | 404](#)
- [Israel | 404](#)
- [Japan | 405](#)
- [Korea | 405](#)
- [United States | 405](#)
- [Nonregulatory Environmental Standards | 405](#)

This topic describes the EMC requirements for the PTX10008 and PTX10016 routers for:

Canada

This Class A digital apparatus complies with Canadian ICES-003.

Cet appareil numérique de la classe A est conforme à la norme NMB-003 du Canada.

The Industry Canada label identifies certified equipment. This certification means that the equipment meets certain telecommunications network protective, operational, and safety requirements. Industry Canada does not guarantee the equipment will operate to the users' satisfaction.

Before installing this equipment, users should ensure that it is permissible to connect the equipment to the facilities of the local telecommunications company. The equipment must also be installed using an acceptable method of connection. In some cases, the inside wiring associated with a single line individual service may be extended by means of a certified connector assembly. The customer should be aware that compliance with the above conditions may not prevent degradation of service in some situations.

Repairs to certified equipment should be made by an authorized Canadian maintenance facility designated by the supplier. Any repairs or alterations made by the user to this equipment, or equipment malfunctions, may give the telecommunications company cause to request the user to disconnect the equipment.



CAUTION: Users should not attempt to make electrical ground connections by themselves, but should contact the appropriate inspection authority or an electrician, as appropriate.

Users should ensure for their own protection that the electrical ground connections of the power utility, telephone lines, and internal metallic water pipe system, if present, are connected together. This precaution may be particularly important in rural areas.

European Community

This is a Class A product. In a domestic environment this product may cause radio interference in which case the user may be required to take adequate measures.

Israel

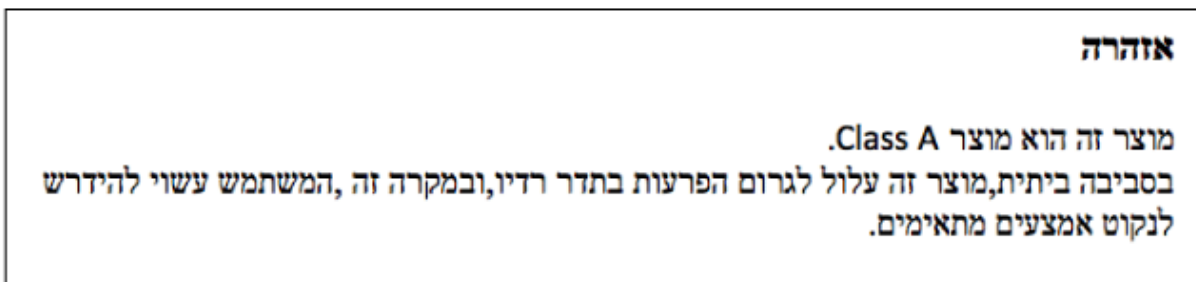

Translation from Hebrew–Warning: This product is Class A. In residential environments, the product may cause radio interference, and in such a situation, the user may be required to take adequate measures.

Japan

この装置は、クラス A 情報技術装置です。この装置を家庭環境で使用すると電波妨害を引き起こすことがあります。この場合には使用者が適切な対策を講ずるよう要求されることがあります。 VCCI-A

The preceding translates as follows:

This is a Class A product. In a domestic environment this product may cause radio interference in which case the user may be required to take adequate measures.

VCCI-A

Korea

이 기기는 업무용(A급) 전자파적합기기로서 판매자 또는 사용자는 이 점을 주의하시기 바라며, 가정외의 지역에서 사용하는 것을 목적으로 합니다.

Korean Class A Warning

9040913

The preceding translates as follows:

This equipment is Industrial (Class A) electromagnetic wave suitability equipment and seller or user should take notice of it, and this equipment is to be used in the places except for home.

United States

The PTX10008 and PTX10016 devices have been tested and found to comply with the limits for a Class A digital device, pursuant to Part 15 of the FCC Rules. These limits are designed to provide reasonable protection against harmful interference when the equipment is operated in a commercial environment. This equipment generates, uses, and can radiate radio frequency energy and, if not installed and used in accordance with the instruction manual, may cause harmful interference to radio communications. Operation of this equipment in a residential area is likely to cause harmful interference in which case the user will be required to correct the interference at his own expense.

Nonregulatory Environmental Standards

These PTX Series product SKUs are designed to be Network Equipment Building System (NEBS) compliant:

- PTX10008
- PTX10016

For specific line card compliance, see [Table 82 on page 406](#).

Those device product SKUs are designed to meet the following NEBS compliance standards:

- SR-3580 NEBS Criteria Levels (Level 3 Compliance)
- GR-1089-CORE, Issue 7: EMC and Electrical Safety—Generic Criteria for Network Telecommunications Equipment
 - The equipment is suitable for installation in locations where the National Electrical Code (NEC) applies.
 - The battery return connection is to be treated as an Isolated DC return (DC-I), as defined in GR-1089-CORE.
- GR-63-CORE: NEBS, Physical Protection
 - The equipment is suitable for installation as part of the Common Bonding Network (CBN).
 - The equipment is suitable for installation in a central office (CO).

Table 82: Line Card Compliance

Line Card Model	Description	Compliance
PTX10K-LC1101	30-port 100-Gigabit or 40-Gigabit Ethernet	NEBS compliant
PTX10K-LC1102	36-port 40-Gigabit Ethernet; 12 ports support either 100-Gigabit or 40-Gigabit Ethernet	NEBS compliant
PTX10K-LC1104	6-port DWDM with MACsec with flexible modulation at 100-Gbps, 150-Gbps, and 200-Gbps	Data center GR 3160 compliant
PTX10K-LC1105	30-port 100-Gigabit or 40-Gigabit Ethernet with MACsec	NEBS compliant

Table 82: Line Card Compliance (Continued)

Line Card Model	Description	Compliance
QFX10000-60S-6Q	60-port 10-Gigabit or 1-Gigabit Ethernet; 2-port of 40-Gigabit or 100-Gigabit Ethernet; 4 port of 40-Gigabit	NEBS compliant
PTX10K-LC1201-36CD	14.4 Tbps—36-port 400-Gigabit, 200-Gigabit, 100-Gigabit, 50-Gigabit, 25-Gigabit, or 10-Gigabit Ethernet This line card is only compatible with the JNP10008-SF3 switch fabric.	NEBS compliant