

Horizontal Unit Heaters – Submittal

HVD-16

Dimensional Data



Steam and Hotwater Coil

MODELS HV-18 THRU 360 (HEADER TYPE)

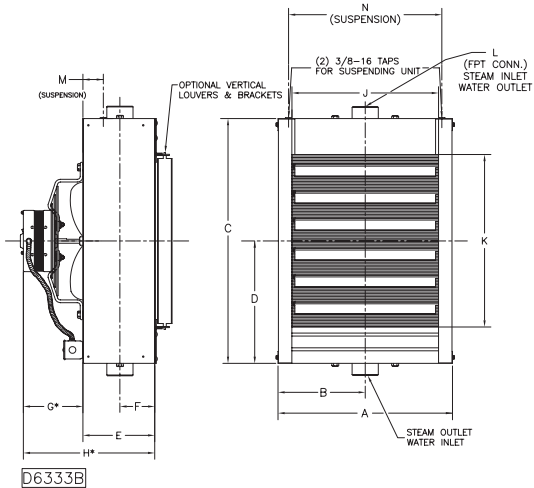

Unit Size	A inches (mm)	B inches (mm)	C inches (mm)	D inches (mm)	E inches (mm)	F inches (mm)	G* inches (mm)	H* inches (mm)	J inches (mm)	K inches (mm)	L inches (mm)	M inches (mm)	N inches (mm)	Number of Louvers	Nom. Fan Diam. inches (mm)	Approx. Ship Wt. lbs. (kg)
18	14 ⁷ / ₈ (371)	7 ⁷ / ₁₆ (186)	15 (381)	7 ¹ / ₂ (191)	6 ¹ / ₈ (156)	2 ¹ / ₈ (75)	3 ¹ / ₄ (83)	9 ⁷ / ₈ (238)	12 ¹ / ₄ (311)	9 ¹ / ₂ (241)	1 ¹ / ₄ (32)	2 ¹ / ₄ (57)	12 ⁷ / ₈ (327)	4	9 (229)	26 (11.8)
24	14 ⁷ / ₈ (371)	7 ⁷ / ₁₆ (186)	18 (457)	9 (229)	6 ¹ / ₈ (156)	2 ¹ / ₈ (75)	3 ¹ / ₄ (83)	9 ⁷ / ₈ (238)	12 ¹ / ₄ (311)	12 ¹ / ₂ (318)	1 ¹ / ₄ (32)	2 ¹ / ₄ (57)	12 ⁷ / ₈ (327)	5	10 (254)	30 (13.6)
36	17 ¹ / ₈ (435)	8 ⁹ / ₁₆ (217)	20 ¹ / ₂ (521)	10 ¹ / ₄ (260)	5 ⁷ / ₈ (149)	2 ¹ / ₈ (75)	5 ¹ / ₁₆ (144)	11 ⁷ / ₁₆ (291)	14 ³ / ₄ (375)	14 ³ / ₄ (381)	1 ¹ / ₄ (32)	1 ³ / ₄ (44)	15 ³ / ₈ (391)	6	12 (305)	41 (18.6)
48	17 ¹ / ₈ (435)	8 ⁹ / ₁₆ (217)	20 ¹ / ₂ (521)	10 ¹ / ₄ (260)	5 ⁷ / ₈ (149)	2 ¹ / ₈ (75)	5 ¹ / ₁₆ (144)	10 ¹ / ₁₆ (278)	14 ³ / ₄ (375)	15 (381)	1 ¹ / ₄ (32)	1 ³ / ₄ (44)	15 ³ / ₈ (391)	6	12 (305)	41 (18.6)
60	18 ³ / ₈ (467)	9 ⁹ / ₁₆ (233)	21 ³ / ₄ (552)	10 ⁷ / ₈ (276)	6 ¹ / ₈ (152)	2 ¹ / ₈ (75)	5 ¹ / ₁₆ (129)	11 ⁷ / ₁₆ (281)	16 (406)	16 ¹ / ₄ (413)	1 ¹ / ₄ (32)	1 ³ / ₄ (44)	16 ⁵ / ₈ (422)	7	14 (356)	44 (19.9)
72	20 ⁷ / ₈ (530)	10 ⁷ / ₁₆ (265)	24 ¹ / ₄ (616)	12 ¹ / ₈ (308)	6 ¹ / ₈ (156)	2 ¹ / ₈ (75)	5 ¹ / ₁₆ (144)	11 ³ / ₁₆ (300)	18 ¹ / ₂ (470)	18 ¹ / ₂ (476)	1 ¹ / ₄ (32)	1 ³ / ₄ (44)	19 ¹ / ₈ (486)	8	14 (356)	47 (21.3)
84	19 ⁵ / ₈ (498)	9 ¹ / ₈ (249)	24 (610)	12 (305)	6 ⁵ / ₁₆ (160)	3 ³ / ₁₆ (81)	7 ¹ / ₂ (191)	13 ¹ / ₁₆ (351)	17 ¹ / ₄ (438)	17 ¹ / ₂ (445)	1 ¹ / ₂ (38)	1 ³ / ₄ (44)	17 ⁷ / ₈ (454)	8	16 (406)	49 (22.2)
108	20 ⁷ / ₈ (530)	10 ⁷ / ₁₆ (265)	25 ¹ / ₄ (641)	12 ³ / ₈ (321)	6 ⁵ / ₁₆ (160)	3 ³ / ₁₆ (81)	6 ¹ / ₁₆ (170)	13 (330)	18 ¹ / ₂ (470)	18 ³ / ₄ (476)	1 ¹ / ₂ (38)	1 ³ / ₄ (44)	19 ¹ / ₈ (486)	8	18 (457)	59 (26.7)
120	23 ³ / ₈ (594)	11 ¹ / ₁₆ (297)	27 ³ / ₄ (705)	13 ³ / ₈ (352)	6 ⁵ / ₁₆ (160)	3 ³ / ₁₆ (81)	7 ¹ / ₂ (194)	14 (349)	21 (533)	21 ¹ / ₄ (540)	1 ¹ / ₂ (38)	1 ³ / ₄ (44)	21 ¹ / ₈ (549)	9	18 (457)	74 (33.5)
144	23 ³ / ₈ (594)	11 ¹ / ₁₆ (297)	27 ³ / ₄ (705)	13 ³ / ₈ (352)	6 ⁵ / ₁₆ (160)	3 ³ / ₁₆ (81)	7 ¹ / ₂ (194)	13 ³ / ₁₆ (349)	21 (533)	21 ¹ / ₄ (540)	1 ¹ / ₂ (38)	1 ³ / ₄ (44)	21 ¹ / ₈ (549)	9	18 (457)	74 (33.5)
156	24 ⁵ / ₈ (625)	12 ³ / ₁₆ (313)	29 (737)	14 ¹ / ₂ (368)	6 ⁵ / ₁₆ (162)	3 ³ / ₁₆ (81)	7 ¹ / ₁₆ (194)	13 ³ / ₁₆ (349)	22 ¹ / ₄ (565)	22 ¹ / ₂ (572)	1 ¹ / ₂ (38)	1 ³ / ₄ (44)	22 ⁷ / ₈ (581)	9	18 (457)	90 (40.8)
204	27 ¹ / ₈ (708)	13 ¹ / ₁₆ (354)	30 ¹ / ₄ (768)	15 ¹ / ₈ (384)	8 ¹ / ₈ (206)	3 ³ / ₁₆ (81)	8 ¹ / ₈ (214)	14 (356)	25 ¹ / ₂ (648)	23 ³ / ₄ (603)	2 (51)	1 ³ / ₄ (44)	26 ¹ / ₈ (664)	10	20 (508)	143 (65)
240	27 ¹ / ₈ (708)	13 ¹ / ₁₆ (354)	30 ¹ / ₄ (768)	15 ¹ / ₈ (384)	8 ¹ / ₈ (206)	3 ³ / ₁₆ (81)	9 ¹ / ₈ (244)	17 ¹ / ₄ (451)	25 ¹ / ₂ (648)	23 ³ / ₄ (603)	2 (51)	1 ³ / ₄ (44)	26 ¹ / ₈ (664)	10	20 (508)	154 (70)
280	30 ³ / ₈ (848)	16 ¹ / ₁₆ (424)	37 ¹ / ₄ (959)	18 ¹ / ₈ (479)	9 (229)	3 ³ / ₁₆ (81)	9 ¹ / ₈ (244)	18 ³ / ₈ (473)	31 (787)	31 ¹ / ₄ (794)	2 (51)	1 ³ / ₄ (44)	31 ³ / ₈ (803)	13	24 (610)	203 (92)

* APPLIES TO STANDARD MOTOR WITH STANDARD FAN GUARD. WHEN OPTIONAL MOTORS OR OSHA FAN GUARDS ARE REQUESTED, DIMENSIONS WILL CHANGE ACCORDING TO THE SUBSTITUTIONS MADE.

- NOTES: 1. OSHA guard standard on models HV-18 thru HV-48 (dimensions shown in table).
 2. Standard motor and standard guard shown in both tables.
 3. Optional OSHA guards available for all units with standard single phase motors.
 4. All three phase and explosion proof motors are shelf mounted.

Serpentine Hotwater Coil

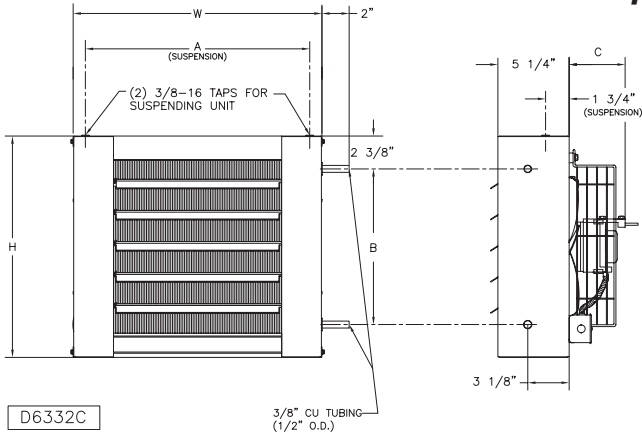

MODELS HV-108A THRU 136A

Unit Size	H inches (mm)	W inches (mm)	A inches (mm)	B inches (mm)	C inches (mm)	Number of Louvers	Nominal Fan Diameter inches (mm)	Approx. Ship Wt. lb. (kg)
108A	16 (406)	18 (457)	16 ¹ / ₃₂ (412)	11 ¹ / ₄ (286)	4 ¹ / ₄ (108)	5	9 (229)	22 (10.0)
118A	16 (406)	18 (457)	16 ¹ / ₃₂ (412)	11 ¹ / ₄ (286)	4 ¹ / ₄ (108)	5	10 (254)	24 (10.9)
125A	16 (406)	18 (457)	16 ¹ / ₃₂ (412)	11 ¹ / ₄ (286)	4 ¹ / ₄ (108)	5	10 (254)	25 (11.3)
136A*	18 ¹ / ₂ (470)	20 ¹ / ₂ (521)	18 ² / ₃₂ (475)	13 ³ / ₄ (349)	5 ¹ / ₁₆ (144)	6	12 (305)	31 (14.0)

* Dimension "C" is to back of motor, not motor conduit connector as shown.
 NOTE: OSHA type fan guard standard on models HV-108A thru HV-136A.



A MESTEK COMPANY

260 North Elm Street
 Westfield, Massachusetts 01085
 (413) 568-9571 • Fax (413) 564-5661
 www.vulcanrad.com

PROJECT: _____
 LOCATION: _____
 ARCHITECT: _____
 ENGINEER: _____
 CONTRACTOR: _____
 PO NUMBER: _____
 DATE: _____



Hot Water Performance Data

Model/ Unit Size	Output BTU Per Hour*	GPM	Final Air Temp	Pressure Drop F/H ₂ O	Motor HP†	Motor RPM	Nominal CFM	Outlet FPM	Nominal Amps At 115VAC**	Sound Rating
HV-108A	8,030	.80	91°F	.80	16 Watt	1550	245	250	.80	II
HV-118A	18,400	1.9	94°F	2.2	16 Watt	1550	500	500	.80	II
HV-125A	24,800	2.5	102°F	2.2	25 Watt	1550	580	590	1.2	II
HV-136A	35,900	3.6	99°F	3.0	1/20	1000	850	550	1.4	II
HV-018B	13,050	1.3	95°F	.005	16 Watt	1550	395	395	.80	II
HV-024B	17,400	1.8	96°F	.014	16 Watt	1550	450	450	.80	II
HV-036B	26,100	2.7	103°F	.09	25 Watt	1350	480	480	1.2	II
HV-048B	34,800	3.5	103°F	.12	1/20	1000	750	550	1.4	II
HV-060B	43,600	4.4	105°F	.17	1/20	1000	900	650	1.4	II
HV-072B	52,300	5.3	104°F	.23	1/20	1000	1100	800	1.4	II
HV-084B	61,000	6.1	106°F	.24	1/12	1000	1400	900	2.2	III
HV-096B	69,700	7.0	106°F	.29	1/12	1000	1400	930	2.2	III
HV-108B	78,400	7.9	100°F	.36	1/12	1000	1800	1000	2.2	III
HV-120B	87,100	8.8	103°F	.39	1/3	1140	1900	900	4.5	III
HV-132B	95,800	9.6	104°F	.41	1/3	1140	2000	950	4.5	IV
HV-144B	104,000	10.4	104°F	.43	1/3	1140	2200	1000	4.5	IV
HV-156B	113,000	11.3	100°F	.53	1/3	1140	2600	1150	4.5	IV
HV-180B	118,000	11.8	110°F	.60	1/3	1140	2200	800	4.5	III
HV-204B	148,100	14.9	107°F	.79	1/3	1140	2900	1000	4.5	IV
HV-240B	174,000	17.4	106°F	1.06	1/3	1140	3500	900	4.5	IV
HV-280B	209,100	21.0	106°F	1.33	1/2	1100	4200	980	5.4	IV
HV-300B	230,000	23.0	102°F	2.1	1/2	1100	5000	700	5.4	IV
HV-360B	261,300	26.2	103°F	2.1	1/2	1100	5500	1000	5.4	IV

Performance based on 200° EWT, 60° E.A.T., 20° TD.
 * For the lower output, an optional Speed Controller must be ordered.
 ** Stated AMP is full load (FLA). AMP draw varies by motor manufacturer ± .2 AMPS.
 † Motor HP listed is applicable to standard motor type only. For explosion proof motor HP, see motor data section.

Steam Performance Data

Model/ Unit Size	Output BTU Per Hour*	Condensate Lbs Per Hour	Square Foot EDR	Final Air Temp	Motor HP‡	Motor RPM	Nominal CFM	Outlet FPM	Nominal Amps At 115VAC†	Nominal Fan Diameter
HV-018B	18,000	18.0	75	102°F	16 Watt	1550	395	395	.80	9"
HV-024B	24,000	24.0	100	109°F	16 Watt	1550	450	450	.80	10"
HV-036B	32,400	32.4	135	120°F	25 Watt	1350	480	480	1.2	10"
HV-048B	43,200	43.2	180	123°F	1/20	1000	750	550	1.4	12"
HV-060B	54,000	54.0	225	131°F	1/20	1000	900	650	1.4	12"
HV-072B	64,800	64.8	270	123°F	1/20	1000	1100	800	1.4	14"
HV-084B	75,600	75.6	315	123°F	1/12	1000	1400	900	2.2	14"
HV-096B	86,400	86.4	360	132°F	1/12	1000	1400	930	2.2	16"
HV-108B	97,200	97.2	405	120°F	1/12	1000	1800	1000	2.2	16"
HV-120B	120,000	120.0	500	118°F	1/3	1140	1900	900	4.5	18"
HV-132B	132,000	132.0	550	121°F	1/3	1140	2000	950	4.5	18"
HV-144B	144,000	144.0	600	120°F	1/3	1140	2200	1000	4.5	18"
HV-156B	156,000	156.0	650	115°F	1/3	1140	2600	1150	4.5	18"
HV-180B	180,000	180.0	770	135°F	1/3	1140	2200	800	4.5	18"
HV-204B	204,000	204.0	850	124°F	1/3	1140	2900	1000	4.5	18"
HV-240B	240,000	240.0	1000	123°F	1/3	1140	3500	900	4.5	20"
HV-280B	280,000	280.0	1100	121°F	1/2	1100	4200	980	5.4	20"
HV-300B	300,000	300.0	1250	117°F	1/2	1100	5000	700	5.4	24"
HV-360B	360,000	360.0	1500	120°F	1/2	1100	5500	1000	5.4	24"

Performance based on 2# steam pressure at heater with air entering @ 60°F.
 Maximum working pressure 150 PSI, 366°F
 * For the lower output, an optional Speed Controller must be ordered.
 † Stated AMP is full load (FLA). AMP draw varies by motor manufacturer ± .2 AMPS.
 ‡ Motor HP listed is applicable to standard motor type only. For explosion proof motor HP, see motor data section.

Steam and Hot Water Coil Specifications

GENERAL

Furnish and install where indicated or scheduled on plans horizontal steam/hot water unit heater. Unit shall be equipped as specified herein. All units shall be installed in a neat and workmanlike manner in accordance with this specification and the manufacturer's installation instructions.

CASING

Casings shall be 20-gauge die-formed steel. Paint finish shall be of lead-free, chromate free, polyester melamine resin base. Finish shall be baked at 400°F.

COIL SIZES 18 - 360

Coil elements and headers shall be of heavy wall drawn seamless copper tubing. Element tubes shall be brazed into extruded header junctions. Pipe connection saddles shall be of cast bronze. Aluminum fins shall have drawn collars to assure permanent bond with expanded element tubes and exact spacing. All Element Assemblies are submersion tested at the factory at 200 PSI. Under maximum conditions, coils are rated at 150 PSI at 366°F for steam and 150 PSI at 320°F for hot water. We recommend operating pressure of 75 PSI at 320°F for long life.

MOTORS

Motors shall be totally enclosed fan cooled, resilient mounted with class "B" windings. All motors shall be designed for horizontal mounting. Motors under 1/3 HP are totally enclosed, frame mounted, 115/1/60 with thermal overload protection and permanently lubricated sleeve bearings with optional solid state speed controller available. 1/3 HP (115/1/60) motors are open frame construction, with thermal overload protection and ball bearings. 1/3 HP at (230 Volt) and all 1/2 HP motors are open frame construction, with thermal overload protection and ball bearings. 1/3 and 1/2 HP motors are available in single and three phase in open frame construction or explosion-proof housings, all the above are available as options.

EXPLOSION PROOF MOTORS

An enclosed motor whose enclosure is designed and constructed to withstand an explosion of a specified gas or vapor which may occur within the motor and to prevent the ignition of this gas or vapor surrounding the machine.

Horizontal unit heater motors comply with the National Electrical Code classification as follows:

- Class I, Group D; all sizes
- Class II, Group F; all sizes
- Class II, Group G; all sizes
- Division I & II Installations
- T-code (T3B)

Explosion proof equipment is not generally available for Class I, Group A and B and it is necessary to isolate motors from the hazardous area. All explosion proof motors are shelf mounted.

FANS

Fans shall be of aluminum blade, hub type designed and balanced to assure maximum air delivery, low motor horsepower requirements and quiet operation. Blades are spark proof.

FAN GUARDS

Fan guards shall be welded steel, zinc plated or painted. Units mounted below 8 feet from floor must be equipped with an OSHA fan guard to meet ETL and OSHA requirements. OSHA fan guard standard on sizes 18 thru 48.

AIR DEFLECTION LOUVERS

Units shall be equipped with horizontal, individually adjustable louvers. Vertical louvers for four-way air control shall be available as an optional extra.

Serpentine Coil Specifications

GENERAL

Furnish and install, where indicated or scheduled on plans, Vulcan Model HVA horizontal hot water unit heaters. Unit shall be equipped as specified herein. All units shall be installed in a neat and workmanlike manner in accordance with this specification and the manufacturer's installation instructions.

CASING

Casings shall be 20-gauge die-formed steel. Paint finish shall be of lead-free, chromate free, polyester melamine resin base. Finish shall be baked at 400°F.

COIL MODELS 108A - 136A

Coil is a serpentine design with seamless copper tubing. Aluminum fins shall have drawn collars to assure permanent bond with expanded tubes. Tubing connection shall be 3/8 in copper tubing, type "M" (.500 OD). Coils shall be factory tested at 200 PSI. Coils have a max operating entering water temperature of 320°F.

MOTORS

Motors shall be totally enclosed fan cooled, resilient mounted with class "B" windings. All motors shall be designed for horizontal mounting.

FANS

Fans shall be of aluminum blade type, designed and balanced to assure maximum air delivery, low motor horsepower requirements and quiet operation.

OSHA FAN GUARDS

OSHA fan guards shall be welded steel, zinc plated or painted. OSHA fan guard standard on sizes 108A thru 136A.

AIR DEFLECTION LOUVERS

Units shall be equipped with horizontal, individually adjustable louvers.

Mounting Heights and Throws

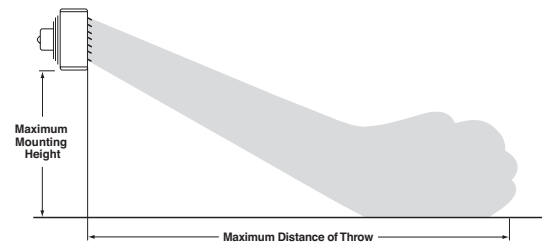

Model/Unit Size	Maximum Mounting Height	Approximate Maximum Throw	Model/Unit Size	Maximum Mounting Height	Approximate Maximum Throw
HV-108A	8'	20'	HV-108	11'	40'
HV-118A	8'	25'	HV-120	12'	40'
HV-125A	9'	29'	HV-132	13'	54'
HV-136A	9'	29'	HV-144	13'	55'
HV-18	8'	20'	HV-156	13'	55'
HV-24	8'	24'	HV-180	13'	53'
HV-36	9'	28'	HV-204	13'	55'
HV-48	9'	30'	HV-240	14'	57'
HV-60	10'	30'	HV-280	14'	57'
HV-72	10'	29'	HV-300	15'	58'
HV-84	10'	30'	HV-360	15'	60'
HV-96	11'	38'			

The following table is based on 60°F entering air and either 2 lbs steam or 200°F TD. The data is based on the higher speed CFM throughout and velocity. Care should be exercised in locating adjacent unit heaters and allowance should be made for obstructions in the air pattern and conflicting air currents from other air moving devices.

Horizontal Unit Heaters

Motor Characteristics

TOTALLY ENCLOSED MOTOR TYPE

Unit Sizes	AMP	MCA	HP	RPM
115/1/60				
18, 24, 108A, 118A	0.8	1	16W*	1550
136A	1.4	1.8	1/20*	1000
36, 125A	1.2	1.5	25W*	1550
48, 60, 72	1.4	1.8	1/20*	1000
84, 96, 108	2.2	2.8	1/12*	1000
120, 132, 144, 156, 180, 204, 240	4.5	5.6	1/3	1140
280, 300, 360	5.4	6.8	1/2	1100
230/1/60				
18, 24, 108A, 118A	0.4	0.5	16W	1550
136A	1.4	1.8	1/20†	1000
36, 125A	0.6	0.8	25W	1550
48, 60, 72	1.4	1.8	1/20†	1000
84, 96, 108	2.2	2.8	1/12†	1000
120, 132, 144, 156, 180, 204, 240	4.5	5.6	1/3†	1140
280, 300, 360	5.4	6.8	1/2†	1100
208-230/460/3/60				
48, 60, 72, 84, 96, 108, 120, 132, 144, 156, 180, 204, 240, 280, 300, 360	2.6-2.6/1.3	3.3-3.3/1.6	1/2**	1140

*Optional variable speed switch is available.

**These motors are without thermal overload protection.

Motors without thermal overload protection must be installed with optional manual starter or field provided overload protection.

NOTE 1: All motors are constant speed and operate at top speed as indicated in motor data. Unit sizes 18 through 108, including 108A, 118A, 125A and 136A can be run at reduced speed with addition of optional variable speed switch. This switch is factory-calibrated for low and high speed ratings, with intermediate speeds infinitely controllable. Models 120 through 360 operate at constant speed as indicated in motor data. All 1/4 HP motors are PSC.

NOTE 2: Motors under 1/3 HP are totally enclosed, frame mounted, 115/1/60 with thermal overload protection and permanently lubricated sleeve bearings with optional speed controller available. 1/3 HP (115/1/60) motors are open frame constant speed with thermal over-load protection and ball bearings. 1/3 HP (230 Volt) and 1/2 HP (230 Volt) motors are open frame constant speed with thermal overload protection and ball bearings.

EXPLOSION PROOF WITH THERMAL OVERLOAD MOTOR TYPE

Unit Sizes	AMP	MCA	HP	RPM
115/1/60				
48, 60, 72, 84, 96, 108, 120, 132	3.7	4.6	1/6	1140
144, 156, 180, 204	5.4	6.8	1/4	1140
240	7.8	9.8	1/3***	1140
280, 300, 360	9.6	12.0	1/2***	1140
230/1/60				
48, 60, 72, 84, 96, 108, 120, 132	3.7	4.6	1/6†	1140
144, 156, 180, 204	5.4	6.8	1/4†	1140
240	3.9	4.9	1/3***	1140
280, 300, 360	4.8	6.0	1/2***	1140
230/460/3/60				
144, 156, 180, 204, 240, 280, 300, 360	2.2/1.1	2.8/1.4	1/3	1140

***These motors are 115/230 volts.

†230/1/60 unit has 115/1/60 motor supplied with field installed stepdown transformer.

NOTE 3: 1/3 and 1/2 HP motors are available as 230 Volt single and 3 phase in open frame and explosion-proof housings, all available as options. 1/3 and 1/2 HP motors operate at single speed only.

NOTE 4: Stated AMP draw is full load amp (FLA). AMP draw varies by motor manufacturer ± .2 AMPS. Verify FLA per unit motor data plate.

CAUTION: Select appropriate AMP and MCA for the multiple voltage motors. For example, the AMP and MCA for Models 360 with a 460 volt Totally Enclosed motor is 1.3 and 1.6 respectively.