

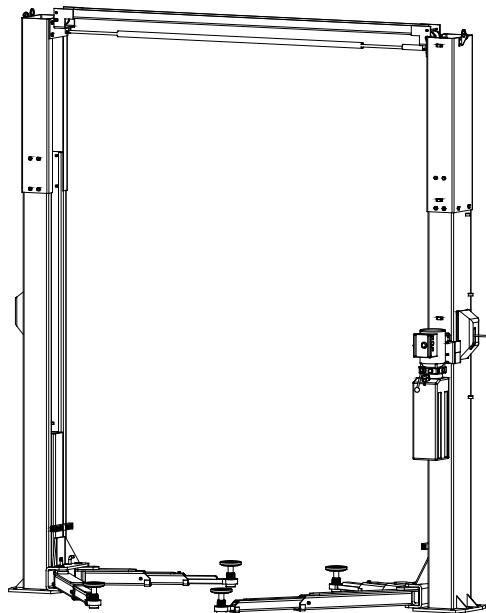

INSTALLATION, OPERATION & MAINTENANCE MANUAL

Two Post Surface Mounted Lift



MODEL Q10

10,000 LBS. CAPACITY
2500 LBS. PER ARM

QUALITY LIFTS, LLC
200 Cabel St., P.O. Box 3972, Louisville, KY 40206
FAX: 502-583-5488
TOLL FREE: 877-771-5438
E-mail: sales@qualitylifts.com
www.qualitylifts.com

**IMPORTANT: READ THIS MANUAL COMPLETELY BEFORE
INSTALLING or OPERATING LIFT**

GENERAL SPECIFICATIONS

See Figure 1	Q10	Q10 w/ 2 Ft. Ext. Kit
A Rise Height (Screw Pads Highest Position)	77 3/4" (2000mm)	
B Overall Height (Adjustable)	147 1/2" (3748mm) / 137 1/2" (3494mm)	171 1/2" (4358mm) / 161 1/2" (4104mm)
C Overall Width	131 3/4" (3347mm)	
D Drive-Thru Clearance	98 3/8" (2499mm)	
E Floor to Overhead Switch	140 1/2" (3568mm)/ 130 1/2" (3314mm)	164 1/2" (4178mm)/ 154 1/2" (3924mm)
F Short Arm Reach	21 3/4"-39 1/4" (553mm-998mm)	
G Long Arm Reach	38 1/4"-55 3/8" (971mm-1407mm)	
H Screw Pad Height	4 1/4"-6 3/4" (109mm-199mm)	
K Inside of Columns	110 1/4" (2800mm)	
L Cylinder Height	148 3/4" (3777mm)	
Lifting Capacity * (Hydraulic Pressure at Cap.)	10,000 lbs. (2800 psi)	
Ceiling Height Required	149" (3785mm)	173" (3809mm)
Motor	2HP, Single Phase, 60Hz	
Voltage	208-230	
Rise Time **	52 seconds	
Max Load Per Arm	2500 lbs (1134 kg)	

* Lift capacity ratings are based on loads equally distributed on all four arms.

** Lifting and lowering speeds may vary depending on the weight of the vehicle.

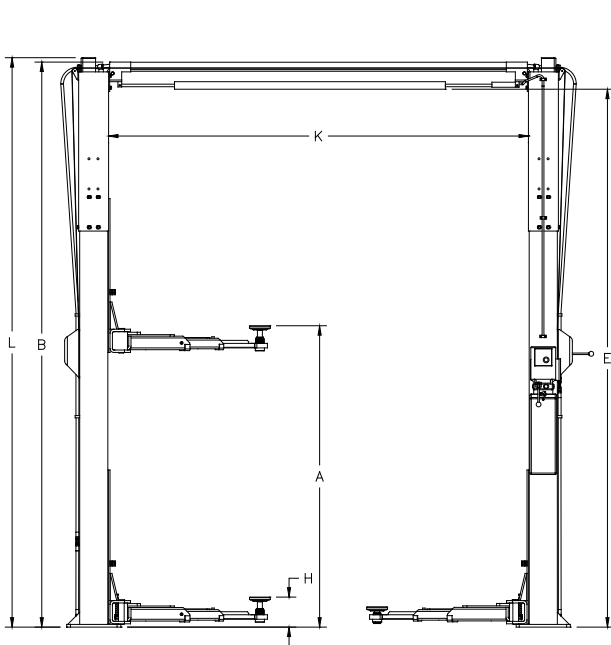

Fig 1a - General Specifications

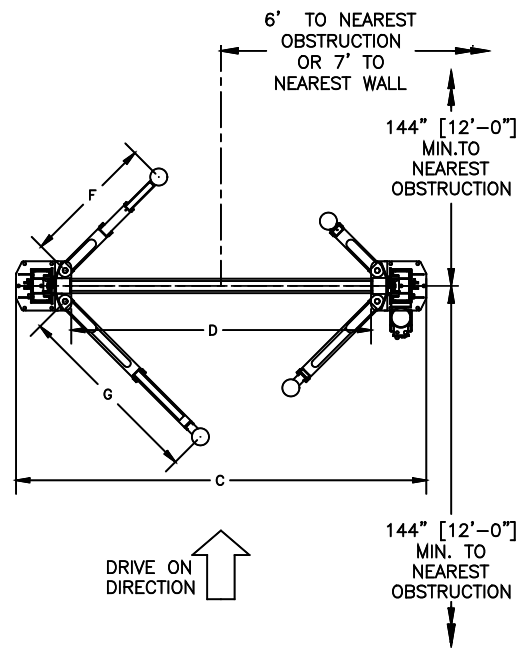

Fig 1b - Service Bay Layout

VERTICAL CLEARANCE

Check the height of the area where the lift is to be installed. Clearance should be calculated based on the full raised height of the lift.



WARNING

Failure by purchaser to provide adequate clearance could result in unsatisfactory lift performance, property damage, or personal injury.

FLOORING

Be certain you have the proper concrete floor to properly handle the loaded lift. Floor should be in generally good condition with no large cracks, spalling or deterioration.

Minimum requirements for concrete are 4 inches minimum depth, with steel reinforcement, 3500 psi, cured for 28 days per local commercial practice. Floor should be level within 3/8 inch over the installation area. No anchors should be installed within 8 inches of any crack, edge, or expansion joint. If these conditions cannot be met, a pad may be poured to accommodate the lift.

Check with local building inspectors and/or permits office for any special instructions or approvals required for your installation.

A qualified person should be consulted to address seismic loads and other local or state requirements.



WARNING

Failure by purchaser to provide the recommended mounting surface could result in unsatisfactory lift performance, property damage, or personal injury.

LOCATION

This lift has been evaluated for indoor use only with an operating ambient temp. range of 5 – 40°C (41– 104°F)

ELECTRICAL REQUIREMENTS

For lift installation and operation it is necessary to have a dedicated circuit with circuit breaker or time delay fuse. Refer to wiring diagram for circuit sizing.

SAFETY NOTICES AND DECALS

For your safety, and the safety of others, read and understand all of the safety notices and decals included here.

READ ENTIRE MANUAL BEFORE ASSEMBLING, INSTALLING, OPERATING, OR SERVICING THIS EQUIPMENT. PROPER MAINTENANCE AND INSPECTION IS NECESSARY FOR SAFE OPERATION. DO NOT OPERATE A DAMAGED LIFT.

Safety decals similar to those shown here are found on a properly installed lift. Be sure that all safety decals have been correctly installed on the Power Unit reservoir. Verify that all authorized operators know the location of these decals and fully understand their meaning. Replace worn, faded, or damaged decals promptly.



WARNING

Do not attempt to raise a vehicle on the lift until the lift has been correctly installed and adjusted as described in this manual.

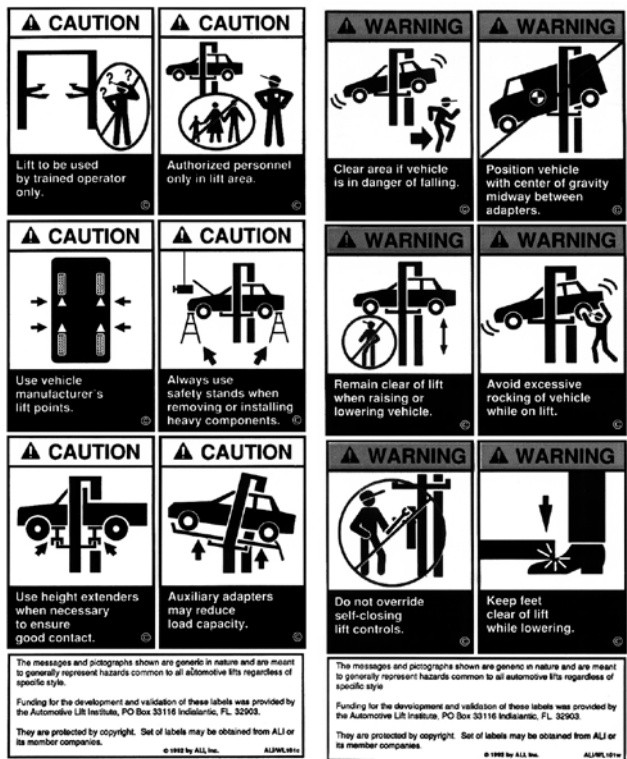

RECEIVING

The shipment should be thoroughly inspected as soon as it is received. The signed bill of lading is acknowledgement by the carrier of receipt in good condition of shipment covered by our invoice.

If any of the goods called for on this bill of lading are shorted or damaged, do not accept them until the carrier makes a notation on the freight bill of the shorted or damaged goods. Do this for your own protection.

NOTIFY **Quality Lifts** AT ONCE if any hidden loss or damage is discovered after receipt.

IT IS DIFFICULT TO COLLECT FOR LOSS OR DAMAGE AFTER YOU HAVE GIVEN THE CARRIER A CLEAR RECEIPT.

File your claim with **Quality Lifts** promptly. Support your claim with copies of the bill of lading, freight bill, and photographs, if available.

Component Packing List

QTY/ LIFT	DESCRIPTION
1	Power Column Assembly
1	Idler Column Assembly
1	Overhead Assembly
1	Hardware Box
1	Power Column Extension
1	Idler Column Extension
2	Rear Arm Assembly
2	Front Arm Assembly
2	Synchronizer Cable Assembly
1	Hydraulic Hose Pack
1	Power Lock Cover
1	Idler Lock Cover

INSTALLATION

IMPORTANT: Always wear safety glasses while installing lift.

TOOLS (MINIMUM REQUIRED)

- a. Tape measure, 16ft
- b. Chalk line
- c. 4ft level
- d. 10" adjustable wrench
- e. Metric open end wrenches 10mm, 13mm, 14mm, 15mm, 17mm, 18mm, 19mm and 24mm
- f. Metric Allen Wrenches 4mm, 5mm, 6mm, and 8mm.
- g. Needle Nose pliers
- h. Snap Ring pliers
- i. Hammer drill with 3/4" diameter carbide tipped bits
- j. 2lb hammer
- k. Torque wrench: 150 foot pounds minimum with 1 1/8" socket
- l. 12 ft. Step ladder
- m. Anti-Seize lubricant (for arm pins and foot pad screw threads and stop rings)

LAYOUT

- 1) Layout the service bay according to the architect's plans or owners instructions (**see Fig 1b**). **Failure to install in this orientation can result in personal and property damage.** Be certain that the proper conditions exist, see page 3.
- 2) Assemble column extension to column using M12 x 30 Hex bolts. Repeat for opposite column and extension. Install power column extension on power column, see **Fig 6**.
- 3) Using the Overall Width (C) Dimension from **Fig 1b**, chalk two parallel lines on the floor within 1/8" tolerance. Erect both column assemblies. Align the base plate edges to the chalk lines.

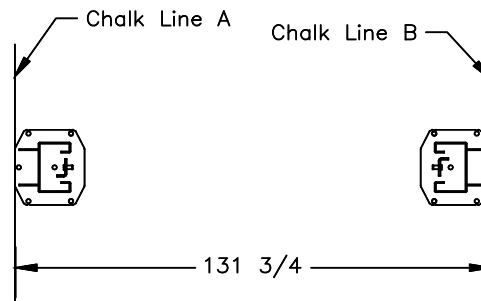

ANCHORING

- 4) The anchor bolts must be installed at least 8" from any crack, edge, or expansion joint.
- 5) Use a concrete hammer drill with a 3/4 inch carbide bit. Tip diameter should conform to ANSI Standard B94.12-1977 (.775 to .787). Do not use excessively worn bits or bits which have been incorrectly sharpened. A core bit may be necessary if an obstruction is encountered. **Never substitute with shorter anchor.**
- 6) Recheck "Inside of Columns" dimension, **Fig 1**. Drill the anchor holes using the base plate as a template. Drill through the floor if possible or to a depth of 5 inches minimum.
- 7) Vacuum dust from the hole for proper holding power.
- 8) Shim both columns to plumb using the shims provided as shown in **Fig 2**. DO NOT shim more than 1/2" at any given point. Use a level no less than 24" in length to plumb columns.
- 9) Assemble washer and nut to anchor with nut just below impact section of bolt. Drive anchor into hole until nut and washer contact base.

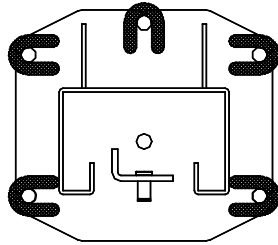

Fig 2 – Column Shimming

- 10) Tighten power column anchors and recheck column for plumb. Re-shim if necessary. Torque to 150 foot-pounds to set anchors.

OVERHEAD

- 11) Raise and install Overhead Assembly using M12 x 30 Hex Bolts.
- 12) Install Overhead Limit Switch under the Overhead Assembly on the Power Side. Route cable around outside of column as shown in **Fig. 6**.
- 13) Check idler column shimming. Use additional shims (**see Fig. 2**) to remove any gaps that may have been created while installing overhead beam. Tighten anchor bolts and recheck column for plumb. Torque to 150 foot-pounds.

SYNCHRONIZER CABLES

- 14) At the upper beam sheave locations disassemble and reassemble the cable trapping rod to install the cable onto the sheave, See **Fig 3**. To install the cable bottom sheave will need to be removed then reassembled.

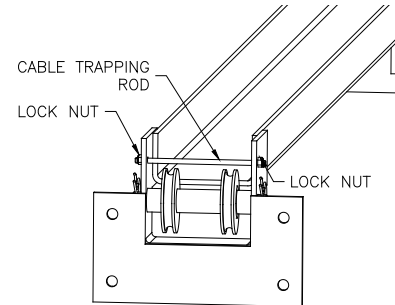

Fig 3-Cable Trapping

- 15) Attach one end of synchronizing cable to carriage. See **Fig 4** for proper attachment.
- 16) Route cable up and over sheave in overhead. Follow across to other sheave on opposite column. Route down through carriage to sheave in bottom of column. Route under sheave and up to cable attachment. Lower attachment point is used for Standard Height Installation (147 1/2") and the Upper attachment point is used for Reduced Height Installation (137 1/2"). Use **Fig 4** for proper attachment.
- 17) Repeat for opposite side.

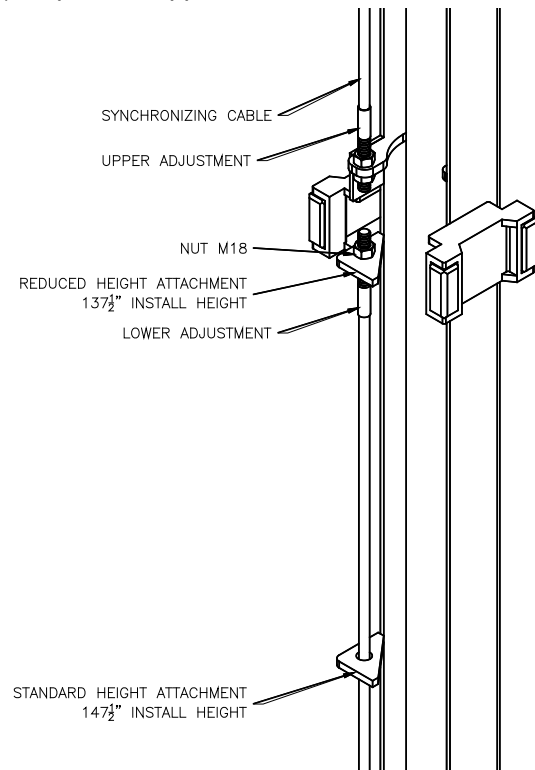

Fig 4 – Synchronizing Cables

POWER UNIT & HYDRAULIC LINES

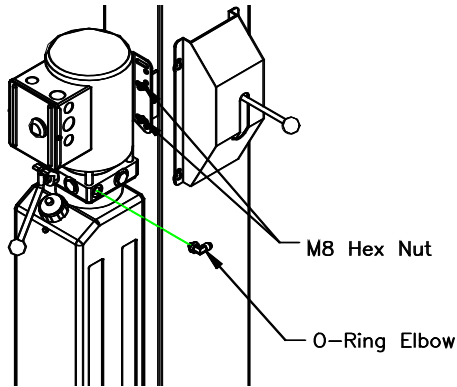

Fig 5 – Power Unit Mounting

- 18) Mount Power Unit to power column as shown in **Fig 5**. The mounting hardware, (4) M8 hex nuts, are pre-installed on power unit mounting bracket.
- 19) Attach Hydraulic elbow fitting threading the O-Ring end into the power unit.
- 20) **IMPORTANT – To insure proper hose fitting seal without damage to the fitting follow this procedure for each hose connection:** Screw flared fitting on finger tight. Rotate flared fitting 1 ½ flats or 90 degrees. Back the flared fitting off one full turn and repeat.
- 21) Thread power unit hose (short) to elbow in power on power unit.
- 22) Beginning on the idler side start with the Idler Extension hose at the elbow fitting (This hose has a male fitting on one end and is removed for reduced height installations). Continue with the Idler Column Hose (long) up the backside of the column through the two capture rings and guide at the top of the extension. Continue across the overhead through each of the guides as shown and down the backside of the power column. **See Fig 6.**

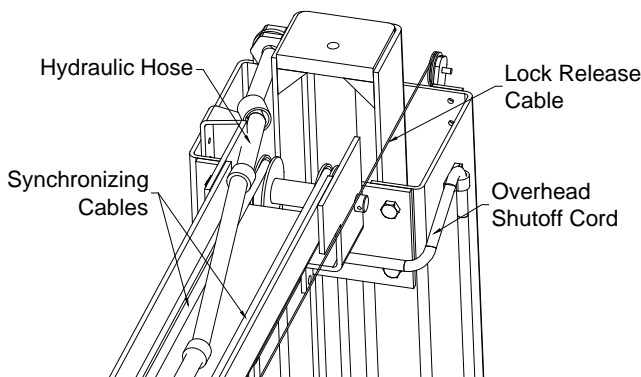
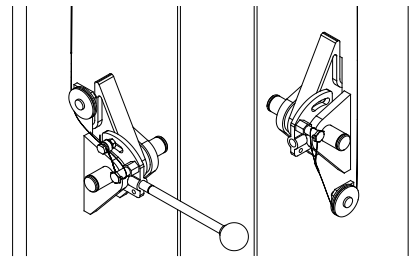

Fig 6 – Hose Routing (Power Side)

- 23) Route the remaining Power column hose beginning at the elbow fitting at the base up the backside of the column. Join the three hoses with the supplied union tee.
- 24) **BE CERTAIN ALL FITTINGS AND CONNECTIONS ARE TIGHT. IT IS THE INSTALLERS RESPONSIBILITY TO INSURE SYSTEM IS LEAK-FREE.** Fill the Power Unit with three gallons of clean 10wt anti-foam anti-rust hydraulic oil or Dexron III ATF. **Do NOT USE OILS WITH DETERGENTS.**

LOCK RELEASE

- 25) Install Lock Release Stud and Knob to the Power Column Lock using one M10 Nut.
- 26) Attach Mechanical Lock Release Cable Assembly to each lock pawl. **See Fig 7.**



POWER SIDE IDLER SIDE
Fig 7 – Lock Assembly

THE LOCK RELEASE CABLE ADJUSTMENT IS NOT COMPLETE UNTIL THE LIFT HAS BEEN LOWERED AND “FINAL ADJUSTMENTS” HAVE BEEN MADE.

ARM INSTALLATION

- 27) Lubricate the arm pin or carriage arm pin hole with “anti-seize” and install the arms. Insure that the arm restraint gears engage and disengage properly. Arm restraints should disengage when lift is fully lowered. If any binding occurs, insure that the large gear mounted to the arm has been factory installed tight against the arm pin.
- 28) Extend the footpad to both extents and apply anti-seize to the three retaining rings and where the double screw makes contact with the base of the footpad.
- 29) Ensure arm stop hardware is present and adequately tightened so that spring lock washer is fully compressed for each arm. Check arm stop engagement by fully extending each arm. Properly installed arm stop hardware will prevent arm from becoming over-extended and possibly disassembled.



Loose or missing arm stop hardware may result in personal injury and/or property damage.

ELECTRICAL

- 30) Refer to **Fig 9 Wiring Diagram** for all steps under this heading.

Single Phase

- 31) Connect the Overhead Limit Switch Cord to Power Unit as shown.
32) Connect Power Unit to suitable electrical source as shown.

Three Phase

- 33) Power unit is factory wired for 240 volt. Refer to wiring diagram or motor plate for optional voltages.
34) Connect Contactor Enclosure to column. Mounting hardware should be centered on the column side to side to avoid the path of the slide blocks.
35) Connect Overhead Limit Switch Cord to Contactor as shown.
36) Connect Contactor to Power unit as shown. Connect Contactor to suitable electrical source as shown.

IMPORTANT: AFTER WIRING HAS BEEN COMPLETED, TEST OPERATION OF POWER UNIT & OVERHEAD LIMIT SWITCH. WHILE RAISING LIFT, OPERATE OVERHEAD SHUTOFF BAR. POWER UNIT MOTOR SHOULD STOP WHEN SHUTOFF BAR IS RAISED.

COLUMN DECAL PLACEMENT

- 37) Apply decal to each column extension as described in **Fig. 8** below.

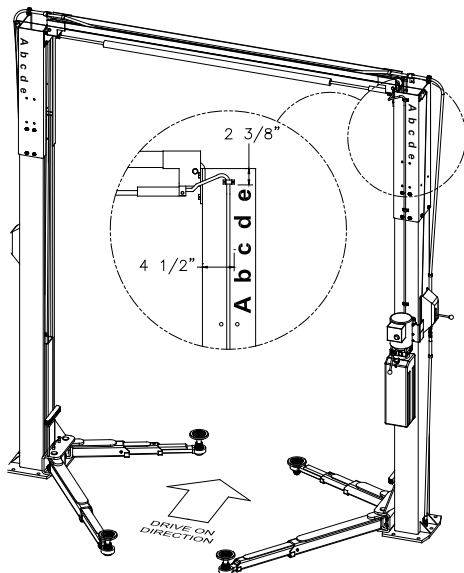

Fig 8 – Decal Placement

FINAL ADJUSTMENTS

HYDRAULICS

- 38) Lower the lift to the floor and raise the lift approximately one foot.

- 39) Start with Idler side first. Slowly and carefully loosen the bleed plug on top side of the cylinder just enough to allow the entrapped air to escape. Repeat for power side.
40) Raise lift 6 inches. Repeat step 39 until no air comes out of cylinder.
41) Pressure test hydraulic system. Energize power unit, raise lift to full rise and continue to run motor for additional 10 seconds. (NOTE: pressure relief will make a high pitch squeal sound for these 10 seconds.) Check hydraulic system for leaks.
42) Energize power unit again for 10 seconds. With a clean rag, wipe down both cylinder rods. (The cylinders are shipped with a small amount of clear anti-corrosive lubricant that will be forced out through the wiper when the lift reaches full rise.) **If lubricant is not wiped clean from the cylinder rod, the cylinder will appear to be leaking.**

SYNCHRONIZING CABLES

- 43) Raise lift and insure carriages lower into same lock position.
44) Adjust synchronizing cables so the tension is equal in both cables and carriages are firmly sitting on locks.
45) Cycle lift to insure that latches operate simultaneously.

LOCK RELEASE CABLE

- 46) Raise lift to a lock position but don't set into the lock. Pull and release Power Column lock release handle while watching Idler Column lock. Adjust Cable tension by removing slack and retightening cable clamp at the power side. **IMPORTANT: IF IDLER SIDE LOCK PAWL DOES NOT FULLY DISENGAGE, DAMAGE MAY RESULT TO IDLER SIDE CARRIAGE AND OR CABLE SYNCHRONIZING SYSTEM.**
47) Remove lock release knob and install both covers. Replace lock release knob.

ARM PIN KEEPER INSTALL

- 48) Slide the arm pin into the carriage, arm, and collar. **Fig 10.**
49) Once the set screw is finger tight against the arm pin, tighten ¼ turn with tool.

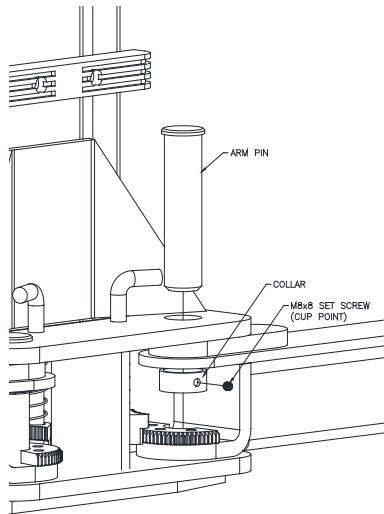

Fig 10 –Arm Pin Keeper Install

OWNER/OPERATOR CHECKLIST

- 50) Demonstrate the operation of the lift to the owner/operator and review correct and safe lifting procedures using the **Lifting It Right** booklet as a guide.
- 51) Complete the Installation Checklist/Warranty Validation questionnaire with the owner. Review the terms of the warranty registration card, and return the card and a copy of the questionnaires to:

QUALITY LIFTS, LLC
200 Cabel St., P.O. Box 3972,
Louisville, KY 40206

Wiring Diagram

EACH LIFT SHOULD HAVE A DEDICATED CIRCUIT WITH A DOUBLE POLE (THREE POLE FOR 440-480V) BREAKER OR TIME DELAY FUSE SIZED ACCORDING TO THE FOLLOWING CHART

	1 ϕ 208-240V	3 ϕ 208V	3 ϕ 220-240V	3 ϕ 440-480V
2Hp	30amp	15amp	15amp	5amp

* WIRING MUST COMPLY WITH ALL LOCAL ELECTRICAL CODES *

FOR SINGLE PHASE

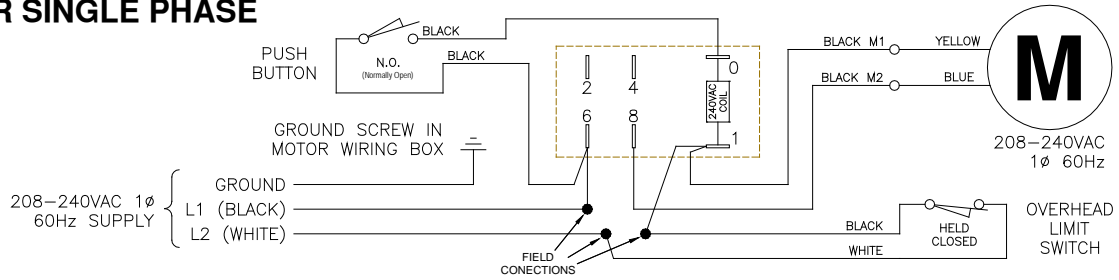

FOR THREE PHASE

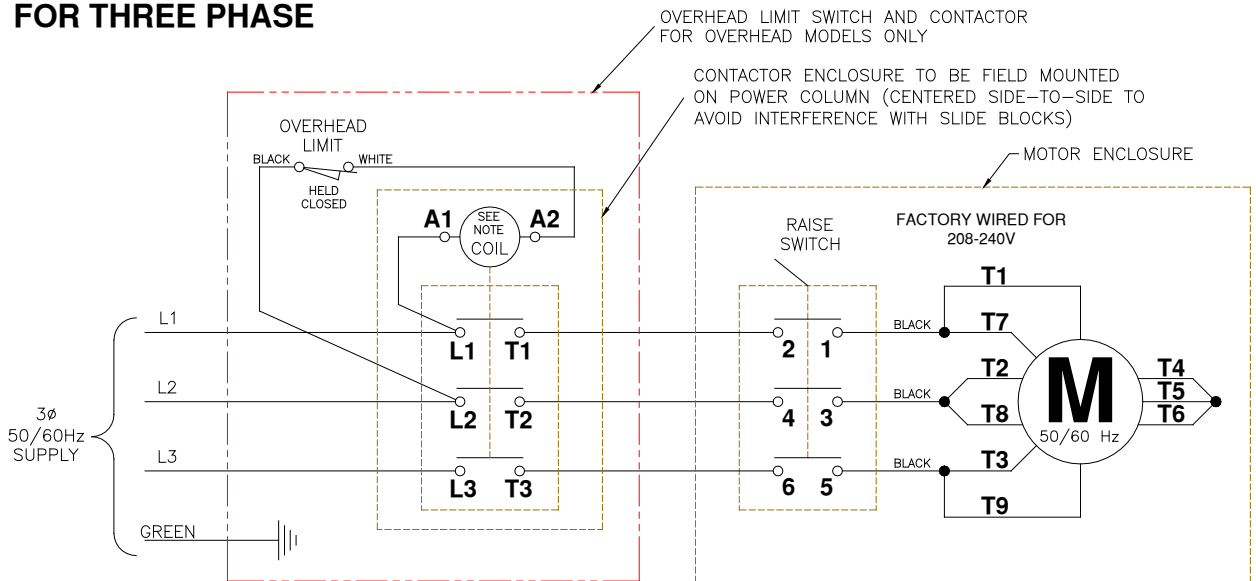

NOTES:

- 1) MOTOR IS FACTORY WIRED FOR 208V OR 220-240V SUPPLY
- 2) MOTOR CONNECTIONS MUST BE RECONFIGURED PER THIS DIAGRAM FOR 440-480V SUPPLY
- 3) CONTACTOR COIL RATING MUST MATCH SUPPLY VOLTAGE (208V, 220-240V, OR 440-480V)
- 4) CONTACTOR MUST BE FIELD MOUNTED ON POWER COLUMN (CENTERED SIDE-TO-SIDE) TO AVOID INTERFERENCE WITH SLIDE BLOCKS)
- 5) MOTOR ROTATION IS COUNTER CLOCKWISE FROM TOP OF MOTOR

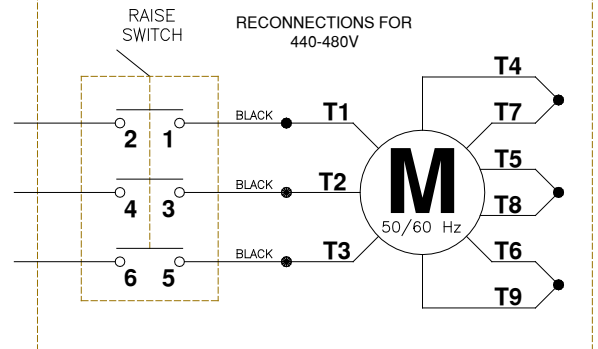

Fig 9 – Electrical Wiring Diagram

OPERATION PROCEDURE

SAFETY NOTICES AND DECALS

This product is furnished with graphic safety warning labels, which are reproduced on page 3 of these instructions. Do not remove or deface these warning labels, or allow them to be removed or defaced. For your safety, and the safety of others, read and understand all of the safety notices and decals included.

OWNER/EMPLOYER RESPONSIBILITIES

This lift has been designed and constructed according to ANSI/ALI ALCTV-2011 standard. The standard applies to lift manufactures, as well as to owners and employers. The owner/employer's responsibilities as prescribed by ANSI/ALI ALOIM-2008, are summarized below. For exact wording refer to the actual standard provided with this manual in the literature pack.

The Owner/Employer shall insure that lift operators are qualified and that they are trained in the safe use and operation of the lift using the manufacturer's operating instructions; ALI/SM 93 -1, ALI Lifting it Right safety manual; ALI/ST-90 ALI Safety Tips card; ANSI/ALI ALOIM-2008, American National Standard for Automotive Lifts-Safety Requirements for Operation, Inspection and Maintenance; ALI/WL Series, ALI Uniform Warning Label Decals/Placards; and in case of frame engaging lifts, ALI/LP-GUIDE, Vehicle Lifting Points/Quick Reference Guide for Frame Engaging Lifts.

The Owner/Employer shall establish procedures to periodically inspect the lift in accordance with the lift manufacturer's instructions or ANSI/ALI ALOIM-2008, American National Standard for Automotive Lifts-Safety Requirements for Operation, Inspection and Maintenance; and the employer shall insure that the lift inspectors are qualified and that they are adequately trained in the inspection of the lift.

The Owner/Employer shall establish procedures to periodically maintain the lift in accordance with the lift manufacturer's instructions or ANSI/ALIOIM-2008, American National Standard for Automotive Lifts-Safety Requirements for Operation, Inspection and Maintenance; and the employer shall insure that the lift maintenance personnel are qualified and that they are adequately trained in the maintenance of the lift.

The Owner/Employer shall maintain the periodic inspection and maintenance records recommended by the manufacturer or ANSI/ALI ALOIM-2008, American National Standard for Automotive Lifts-Safety Requirements for Operation, Inspection and Maintenance.

The Owner/Employer shall display the lift manufacturer's operating instructions; ALI/SM 93 -1, ALI Lifting it Right safety manual; ALI/ST-90 ALI Safety Tips card; ANSI/ALI ALOIM-2008, American National Standard for Automotive Lifts-Safety Requirements for Operation, Inspection and Maintenance; and in the case of frame engaging lift, ALI/LP-GUIDE, Vehicle Lifting Points/Quick Reference Guide for Frame Engaging Lifts; in a conspicuous location in the lift area convenient to the operator.

IMPORTANT SAFETY INSTRUCTIONS

When using your garage equipment, basic safety precautions should always be followed, including the following:

1. Read all instructions.
2. Care must be taken as burns can occur from touching hot parts.
3. To reduce the risk of fire, do not operate equipment in the vicinity of open containers of flammable liquids (gasoline).
4. Keep hair, loose clothing, fingers, and all parts of body away from moving parts.
5. Use only as described in this manual. Use only manufacturer's recommended attachments.
6. ALWAYS WEAR SAFETY GLASSES. Everyday eyeglasses only have impact resistant lenses, they are not safety glasses.

SAVE THESE INSTRUCTIONS

LIFTING A VEHICLE

- 1) Insure that the lifting arms are parked, out to full drive thru position.
- 2) Center the vehicle between the columns in the service bay and position the vehicle's center of gravity midpoint between the columns. NOTE: the center of gravity is based on the weight distribution and is not the same as the center point of the vehicle.

DO NOT EXCEED 2500 POUNDS PER ARM.

DO NOT ATTEMPT TO LIFT THE VEHICLE WITH ONLY TWO ARMS, AS THIS WILL VOID THE WARRANTY

INSURE THAT THE HIGHEST POINT ON THE VEHICLE WILL CONTACT THE OVERHEAD LIMIT SWITCH BAR.

DO NOT PLACE THE VEHICLE IN THE SERVICE BAY BACKWARDS.

WHEN LIFTING FRAMED VEHICLES IT IS SUGGESTED THAT YOU USE THE FRAME ENGAGING ADAPTERS ((10318) OPTIONAL). FAILURE TO DO SO ON SLICK (UNDERCOATED) AND/OR PITCHED FRAME RAILS MAY RESULT IN PERSONAL OR PROPERTY DAMAGE.

REFER TO THE VEHICLE MANUFACTURERS SERVICE MANUAL, TECHNICAL BULLETINS, "VEHICLE LIFTING POINTS GUIDE" (ALI/LP-GUIDE) OR OTHER PUBLICATIONS TO LOCATE THE RECOMMENDED LIFTING POINTS.

- 3) Position the arms and adapters so all four pads contact the vehicle simultaneously.

The vehicle should remain level during lifting.

- 4) Raise the lift until all four wheels are off the ground. Test the stability of the vehicle by attempting to rock the vehicle. Check adapters for secure contact with vehicle lift points. If the vehicle seems unstable, lower the lift and readjust the arms. If the vehicle is stable, raise the vehicle to a height a few inches above the desired working height.
- 5) Lower the vehicle until the safety latches on both columns engage. The vehicle should remain level when both latches are engaged. If one side engages and the other continues to descend, stop lowering the vehicle, raise it several inches, and try again to engage both latches.

Always lower lift into locks before entering the area beneath the vehicle.

Always use safety stands when removing or installing heavy components.

LOWERING A VEHICLE

- 1) Insure that the area under the vehicle is clear of personnel and tools.
- 2) Raise the vehicle until both latches are free.
- 3) Disengage the latches by pulling down and holding the lock release lever.

- 4) Lower the vehicle by depressing the lowering valve handle.

- 5) Continue to lower the vehicle until the carriages stop against the base plate. Retract the extension arms, and park them.

LOSS OF POWER

If for any reason the lift will not raise off the locks or the locks will not retract, consult factory authorized personnel.

DO NOT OVERRIDE ANY SAFETY FEATURE IN AN ATTEMPT TO LOWER THE LIFT.

MAINTENANCE

To avoid personal injury, permit only qualified personnel to perform maintenance on this equipment. Maintenance personnel should follow lockout/tagout instructions per ANSI Z244.1.

The following maintenance points are suggested as the basis of a routine maintenance program. The actual maintenance program should be tailored to the installation. See ANSI/ALI ALOIM booklet for periodic inspection checklist and maintenance log sheet.

- If lift stops short of full rise or chatters, check fluid level and bleed both cylinders per Installation Instructions.
- Replace all Safety, Warning or Caution Labels if missing or damaged (**See Installation instructions page 3.**)

Daily

- Keep lift components clean.
- Check for loose or broken parts.
- Check hydraulic system for fluid leaks.
- Check arm stop hardware and engagement by fully extending each arm. If arm stop hardware is loose, tighten hardware until spring lock washer is fully compressed.
- Check adapters for damage or excessive wear. Replace as required with genuine Challenger Lifts parts.
- Check lock release activation. When properly adjusted, the idler column lock should rest firmly against the back of the column when engaged and pull clear of the column back when disengaged.

Weekly

- Check synchronizer cables and sheaves for wear. Replace as required with genuine Challenger Lifts parts.
- Check lock release cable adjustment per Installation Instructions step 46.

IMPORTANT: IF IDLER SIDE LOCK PAWL DOES NOT FULLY DISENGAGE, DAMAGE MAY RESULT TO IDLER SIDE CARRIAGE AND OR CABLE SYNCHRONIZING SYSTEM.

- Check synchronizer cable tension per Installation Instructions. Adjust if necessary.

Monthly

- Torque concrete anchor bolts to 80 ft-lbs.
- Check overhead shutoff switch. While raising lift, operate overhead shutoff bar. Power Unit motor should stop when bar is raised.
- Lubricate carriage slide tracks with heavy viscous grease. (Grease all (4) corners of both columns.)
- Visually inspect concrete floor for cracks and/or spalls within 12" of base plate

If any problems are encountered, contact your local service representative.

WARRANTY REGISTRATION FORM

SERIAL # _____ INV. DATE: _____

DISTRIBUTED BY: _____

ADDRESS: _____

CITY: _____ STATE: _____ ZIP: _____

CUSTOMER INFORMATION

COMPANY NAME: _____

CONTACT: _____

PHONE NUMBER: _____

ADDRESS: _____

CITY: _____ STATE: _____ ZIP: _____

Please remit form to: **Quality Lifts**
 P.O. Box 3972
 Louisville, KY 40201-3972
 (877) 771-5438 office
 (502) 583-5488 fax

This form must be received by Quality Lifts for warranty to become effective!

Parts Breakdown

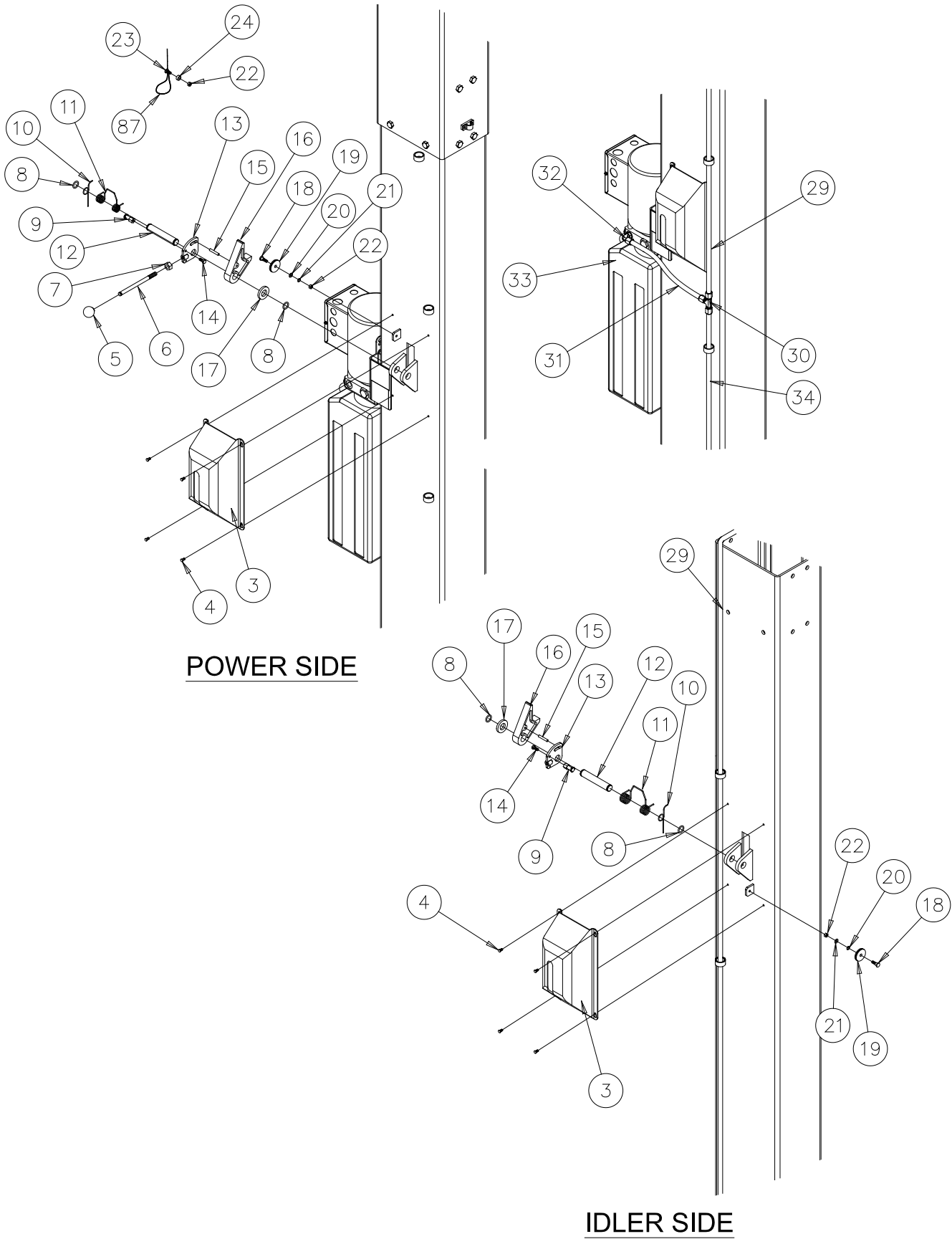

Model Q10
 Installation, Operation and Maintenance

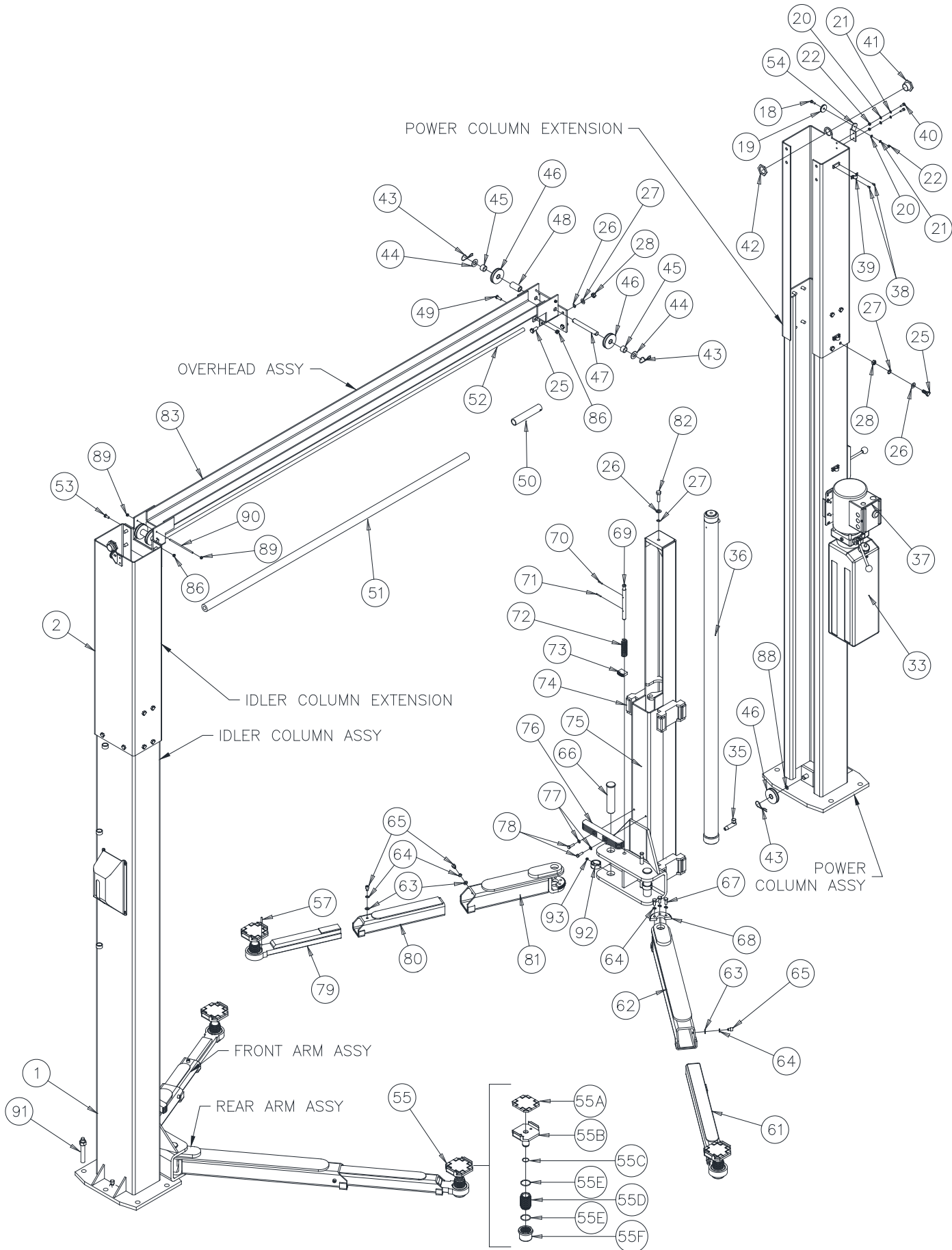

Model Q10
Installation, Operation and Maintenance

Item #	Part #	Qty	Description	Item #	Part #	Qty.	Description
1	JSJ5-02-01-00	1	Power Column Weld	46	JSJ3-03-02	6	Synch. Sheave
	JSJ5-02-01-00f	1	Idler Column Weld	47	JSJ4-03-03	2	Axle
2	JSJ5-02-02-00Q	1	Power Extension Weld (Std. Ht)	48	JSJ4-03-05	2	Middle Spacer Sleeve
	JSJ5-02-02-00H	1	Power Extension Weld (2Ft. Ext. Ht)	49	X10-060	2	Bolt M8 x 25
	JSJ5-02-02-00fQ	1	Idler Extension Weld (Std. Ht)	50	36027	1	Limit Switch
	JSJ5-02-02-00fH	1	Idler Extension Weld (2Ft. Ext. Ht)	51	JSJ5-03-03Q	1	Shutoff Bar Cushion
3	JSJ5-02-14	1	Power Lock Cover	52	JSJ5-03-02Q	1	Shutoff Bar
	JSJ5-02-14F	1	Idler Lock Cover	53	X10-063	1	Bolt M8
4	X10-065	8	Screw M5 x10	54	JSJ4-02-11-00	1R/1L	Pulley Bracket
5	JSJ3-01-02-2-9	1	Lock Release Knob	55	B2270	4	Foot Pad Assembly
6	JSJ5-02-06	1	Lock Release Stud	55A	A1104-H	4	Rubber Insert
7	X10-019	1	Nut M10	55B	A1101-1H	4	Foot Pad Weld
8	X10-020	4	"C" Ring 20	55C	B17256	4	2x30 Retaining Ring
9	JSJ5-02-12	2	Lock Release Wire Pin	55D	B2261	4	Threaded Sleeve
10	JSJ5-02-13	2	Lock Release Spring 1	55E	B17257	8	3x45 Retaining Ring
11	JSJ5-02-07	2	Lock Release Spring 2	55F	B17276-1	4	Threaded Insert
12	JSJ5-02-04	2	Lock Release Shaft	57	B2211	4	Roll Pin, ø6x30
13	JSJ5-02-10	2	Lock Release Cam	61	JSJ5B-09-02-00CH	2	Rear Male Arm
14	X10-026	2	Bolt M6	62	JSJ5B-09-01-00B	2	Rear Female Arm
15	X10-027	2	Spring Pin 6 x 35	63	X10-073	6	Washer 10mm
16	JSJ5-02-03	2	Lock Pawl	64	X10-074	18	Spring Washer 10mm
17	X10-029	2	Washer	65	X10-075	6	Screw M10
18	JSJ4-02-08	4	Pulley Axle	66	JSJ5-11	4	Arm Pin
19	JSJ4-02-09	4	Pulley	67	X10-077	12	Screw M10 x 25
20	X10-032	8	Washer 6mm	68	JSJ5-09-07	4	Inner Gear
21	X10-033	8	Spring Washer 6mm	69	JSJ5-13Q	4	Arm Restraint Pin
22	X10-034	9	Nut M6	70	X10-080	4	Spring Pin 4 x 24
23	JSJ5-06-01	1	Bolt (Cable Clamp)	71	X10-081	4	Spring Pin 4 x 30
24	JSJ5-06-02	1	Sleeve	72	JSJ4-14	4	Arm Restraint Spring
25	X10-037	28	Bolt M12 x 30	73	JSJ4-12	4	Outer Gear
26	X10-038	28	Washer 12mm	74	JSJ5-08-15	16	Slide Block
27	X10-039	28	Spring Washer 12mm	75	JSJ5-08-00Q	2	Carriage
28	X10-040	28	Nut M12	76	JSJ4-05CH	2	Door Guard
29	JSJ5-18Q	1	Idler Column Hose	77	X10-087	4	Washer 8mm
29a	JSJ5-21Q	1	Idler Extension Hose	78	X10-088	4	Bolt M8 x 30
30	JSJ4-15	1	Union Tee	79	JSJ5B-10-03-00CH	2	Front Male Arm
31	JSJ5-17	1	Power Unit Hose	80	JSJ5B-10-02-00	2	Front Intermediate Arm
32	JSJ5-19	1	O-Ring Elbow	81	JSJ5B-10-01-00	2	Front Female Arm
33	AB-9367	1	Power Unit	82	X10-092	2	Bolt M12 x 45
	AD-9367		Power Unit, 3Phase	83	JSJ5-03-01-00Q	1	Overhead Weld
34	JSJ4-16	1	Power Column Hose	84	JSJ5-04-00Q	2	Sync. Cable (Std. Ht)
35	JSJ6-19	2	Elbow, O-Ring		JSJ5-04-00H	2	Sync. Cable (2Ft Ext Ht)
36	JSJ5-07-00	2	Cylinder, O-Ring	85	X10-095	6	Nut M16
37	X10-048	4	Nut M8	86	X10-096	2	Lock Nut M10
38	X10-049	10	Bolt M5 x 8	87	JSJ5-06	1	Lock Release Cable (Std. Ht)
39	JSJ5-02-02-03	5	Plate-Shutoff Cord Clamp		JSJ5-06H	1	Lock Release Cable (2Ft Ext Ht)
40	X10-051	4	Bolt M6 x 20	88	X10-099	4	Washer 20mm
41	JSJ4-02-17	2	Hose Guide	89	B31061	4	M6 Lock Nut
42	JSJ4-02-18	2	Hose Guide Nut	90	JSJ5-03-07ch	2	Cable Trapping Rod
43	GJY12-3	6	Hair Pin Cotter	91	31058	10	¾"x5- ½" Concrete Anchor
44	X10-055	4	Washer	92	JSJ5-22CH	4	40.5 x 48 x 20 Lg. Collar
45	JSJ4-03-06	4	Spacer Sleeve	93	JSJ5-23CH	4	M8 x 8 Set Screw Cup Point
					JSJ5-21H	1	Extension Hose (2Ft.Ext. Height)

IMPORTANT

Replace all worn or broken parts with **genuine Quality Lifts parts**. Contact your local Quality Lifts parts distributor for pricing and availability. Call Quality Lifts, Inc. at **(502) 583-5438** for the distributor in your area.

Model Q10
Installation, Operation and Maintenance

NOTES