

28222R

SET-UP GUIDE

This Freesat™ Installation Kit, can be fitted by a competent DIYer, but please note warnings below.



WARNING

Every satellite dish installation is different in nature. To fit suitable brackets, fixings and poles/masts you need to take into consideration: a.) The state and type of surface being mounted to. b.) The weight of the assembly to be mounted c.) The exposure to and effect of prevailing winds. *Fixings and brackets supplied with this product may not be suitable for your particular installation.* If in doubt please consult a CAI registered installer.

GENERAL SAFETY

The risk of accidents can be greatly reduced by planning before starting a project.

Before starting installation check structure is sound and check for hidden electrical wiring or plumbing. • When working on an installation outside, beware of overhead power lines. • Observe safe working practices, tread carefully and ensure adequate lighting is available in loft or roof space. • Before making any connections switch electricity off at the mains. • Always follow manufacturer's operating and safety instructions before using tools and/or equipment. • Only carry out work outdoors at height if you are competent in the use of ladders and related access equipment. • Always read and follow the manufacturer's instruction label affixed to the ladder. • To avoid injury always route cables or wiring carefully. Ensure cable is correctly routed before fixing into position, taking care not to over tighten cable clips. • This product may contain small parts - keep out of reach of children. • After installation make regular maintenance checks for wear and tear.

List of Dish Assembly Parts - for the rest of kit contents see page 4

No.	Image	Description	Qty.
1		M6 x 20mm bolts for LNB holder	2
2		M6 x 12mm bolts for swivel bracket/LNB holder	5
3		PVC LNB arm inserts	2
4		M6 x 30mm bolts for LNB arm	2
5		M6 x 16mm bolts for dish fixing	4
6		M6 flange nuts for dish bracket	4
7		Washers	9
8		M6 x 55mm bolts for mast clamp	2
9		M6 x 50mm expansion bolts	4
10		PVC cap for wall mount arm	1
11		Satellite dish	1
12		dish bracket	1
13		LNB arm	1
14		Mast bracket	1
15		Mast clamp	1
16		Upper part 40mm LNB holder	1
17		Lower part 40mm LNB holder	1
18		Wall mount arm Ø32mm	1
19		M6 nuts for LNB holder	2

1) Identify your South Facing Wall: The dish needs to be on a South facing wall in order to pick up the Astra 2A, 2B, 2D and Eurobird1 satellites. Identify your south facing wall and look to mount your satellite dish on the outside of the wall, at the nearest point to your main TV. Tip: Look at your neighbours' houses someone is sure to have Sky, see which way their dish is facing. If none of your neighbours have Sky, you can use a compass to determine which wall faces south.

Please note that the mounting bracket can be mounted on either a wall or a flat roof.

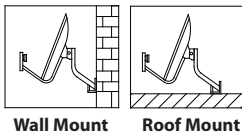

2) Check line of sight: Make sure there are no obstructions (trees/tall buildings) in line between the dish and the satellites. The following website gives bearing/direction by postcode, country: <http://www.dishpointer.com>

3) Assemble the Dish and Brackets:

Before assembly check that your kit contains all the items listed above. Assemble the dish and brackets as shown in the diagram but do not yet attach to the wall mount arm (18).

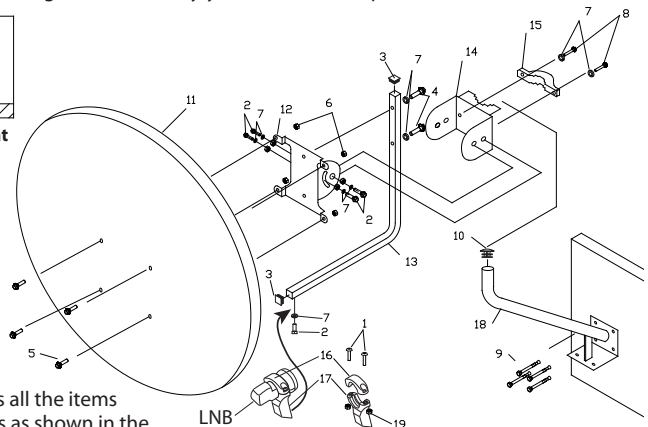

4) Mount the Wall Bracket: Mount the wall bracket (18) using the expansion bolts (9). Make sure that the mounting holes are drilled into brick or stone and not into the mortar. Also ensure that the wall mount is horizontal and perfectly level (check using a spirit level).

5) Attach Dish Assembly to Wall Bracket:

The complete dish assembly can now be attached to the wall bracket.

6) Prepare Digital Coax Cable: Firstly fit the LNB rubber weather boot provided, to the dish end of the cable. Fitting the F connector: Strip the end of the cable as shown below. Once you have stripped the cable, twist the braid and pull it back on itself, make sure that no braid is touching the copper core, this will cause a short on the cable and you will not get any signal. Now, simply twist on the 'F' connector and connect to the LNB making sure that the weather boot is correctly secured over the LNB connector.

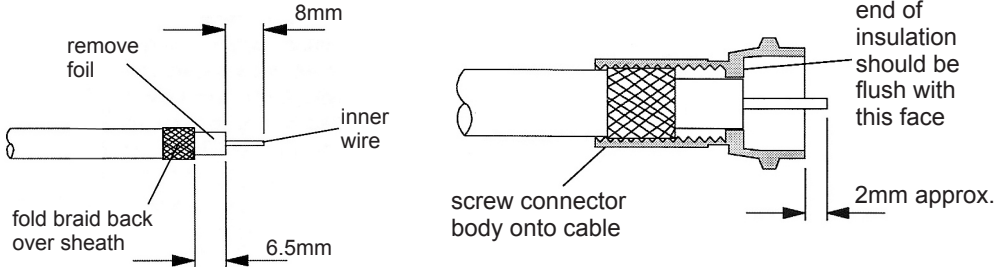

7) Run Cable Down the Wall: Once you have installed the dish you need to run the cable to the room in which your receiver is going to be installed. Start at the top and work down, you should clip the cable every 50cm, always run the cable horizontally or vertically, never diagonally across a wall.

8) Connect Cable to Satellite Receiver: The cable can be run into the room by drilling a hole in through the window frame or the wall. Once you have run the cable through to where you intend to position the receiver, cut off any surplus cable and then fit the 'F' connector following the instructions in step 6. Screw the 'F' connector to the LNB-in terminal on your decoder.

9) Connect Satellite Receiver to your TV: Use a SCART lead and tune the TV into AV1.

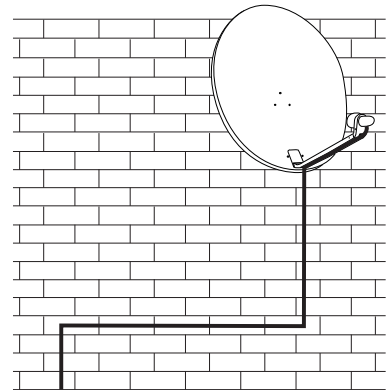

10) Align Satellite Dish: To obtain accurate settings go to the website: <http://www.dishpointer.com> Enter your location and select satellite 28.2E Astr 2A, 2B, 2C and 2D. By locating your area on the map on the website, the programme will give the precise settings that you will require to align to the satellites. If you do not have access to the internet we have enclosed a chart showing settings for the key areas in the UK and Republic of Ireland. Identify the town nearest to you and work on those settings.

Three settings are required:

- a) **Dish elevation** - this is the angle that the dish has to be pointed at the sky. This is done by aligning to the correct angle on the elevation bracket.
- b) **Polarisation angle** - this is the angle at which the LNB needs to be set at in its mount. The LNB angle can be adjusted by loosening the screws of the LNB mount and twisting the LNB to the correct position.
- c) **Azimuth angle** - This is the compass direction required. For initial setting you can use the compass supplied and then the satellite finder. For fine tuning you will need two people, one person to align the dish and the other to watch the TV screen for a signal quality and strength.

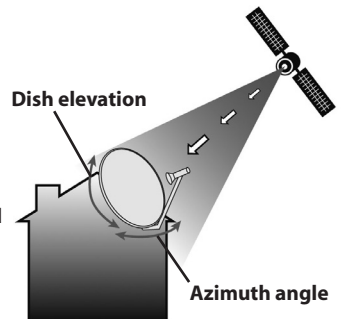

11) A satellite finder and a compass: have been included in the kit to help you locate the satellite and set your dish in the optimum position.

a. First disconnect the download from the LNB mounted on your satellite dish and connect the jumper lead supplied in its place, connect the other end of the jumper lead to the F connection on your Satellite Finder marked "Satellite LNB".

b. Next connect the download (connected to the receiver) to the "Receiver" connection on your Satellite Finder.

c. Ensure that your satellite receiver is switched on. The Satellite Finder's power and signal strength LEDs will light up, using the level control peg adjust the level control to reduce the number of lit red LEDs to 2 or 3 by turning the control anti-clockwise (the pitch of the audible tone will also reduce).

d. Set your satellite dish to the correct azimuth and elevation settings. Using the compass supplied align the red arrow to North 0° and then read off the correct azimuth angle.

e. Slowly scan the sky with the satellite dish (side to side movement) from around 5° either side of the correct azimuth angle. The number of LEDs lit and the pitch of the tone will increase/decrease, if it does not then adjust the elevation by half a degree and repeat the scan.

f. Keep adjusting the azimuth and elevation of the satellite dish so that you obtain the highest reading possible. An audio signal also indicates the signal strength. If the signal reading goes beyond '6' on the scale turn the Level Control anti-clockwise to reduce the reading to '2'.

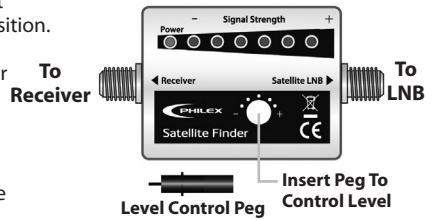

PLEASE NOTE: Do not use the Satellite Finder directly in front of your satellite dish - this can result in a continuous full scale reading (ie. above '6' LEDs). If the meter reading keeps jumping then adjust the Level Control on the Satellite Finder. Turn anti-clockwise to lower the sensitivity.

12) Fine Tuning: Once you have set the dish position using the satellite finder you can fine tune the position using the satellite receiver. Locate the signal levels function on your satellite receiver's menu

You will probably notice that there is some signal strength straight away, don't get excited, this is only reading 'noise' from the atmosphere. It is the signal **quality** that you need to concentrate on; this is reading a specific transponder from the Astra 2A, 2B, 2D and Eurobird satellites.

With one person watching the screen, the other person needs to move the dish slowly around until the signal quality and strength display starts to read a decent signal level, about 50% should be fine. The dish needs to be within 0.1 of a degree of the satellite position (about 1mm in movement terms) when making these adjustments, the quality and signal strength meter on the screen takes up to 5 seconds to register the signal, so you can't just sweep the dish around the sky, you need to make very precise, very subtle movements of the dish, stopping for a few seconds after each movement. **PLEASE NOTE Do not scan or search until you have a good signal QUALITY reading (50%+).**

If the Signal quality and strength readings are low on screen, but the satellite finder is indicating a strong signal then you are aligned to another satellite, select other available satellites that may be giving a high signal strength like Hotbird 13 E or Astra 1 19.2E, If Hotbird 13E shows high Signal and Quality level readings on screen, you need to turn the dish 14 degrees towards the East to find the Astra 2 satellite, you may find another satellite as you turn the dish, which is Astra 1 19.2E, If Astra 1 19.2E shows high Signal and Quality level readings on screen, you need to turn the dish 9 degrees towards the East to find Astra 2.

Once you have some signal quality and strength, make tiny movements of the dish horizontally and vertically to find the best signal quality. When you have at least 50% signal quality, tighten the dish up, remove the jumper cable and your Satellite Finder, then reconnect the LNB to your satellite receiver. Your dish installation is complete.

Should you experience any difficulty in setting up your Free-to-Air Digital Satellite Kit, download: [technical.philex.com/downloads/Free to Air Satellite Installation Instructions.pdf](http://technical.philex.com/downloads/Free%20to%20Air%20Satellite%20Installation%20Instructions.pdf) (or call our Customer Careline: **0901 293 0038**. Calls are charged at £1 per minute from a BT landline. Call charges from other networks may vary.)

To locate a CAI approved Satellite Installer in your area you can connect to the CAI website <http://cai.org.uk/asp/installer.asp>

Other useful websites:

<http://www.liveonsat.com>

<http://www.lyngsat.com>

<http://www.satcodx.com>

<http://www.dishpointer.com>

Suggested list of useful tools not included:

Masonry drill and bit, adjustable wrench or spanners, crosshead screwdriver, spirit level, hammer and cable strippers.

Kit Contents:

- 60 cm satellite dish with fixings and wall mount
- Digital Low Noise Block (LNB)
- 10 Metres of Digital Coaxial Cable
- Cable clips
- 2x F type connectors
- Weather boot
- SCART lead
- Satellite finder
- Compass

Satellite alignment settings for Astra 2A, 2B, 2D and Eurobird 1

28.2 Degrees East for the UK and Ire (English Language Channels)

For other satellite settings see www.dishpointer.com

Mainland UK

Town	County	Elevation	Azimuth	Polarization
Aberdeen	Aberdeenshire	19.76	145.17	-10.55
Abergavenny	Gwent	23.96	142.37	-14.66
Aberystwyth	Dyfed	23.05	141.46	-14.84
Alnwick	Northumberland	21.39	145.06	-11.48
Amptill	Bedfordshire	24.77	145.24	-13.03
Athlone	West Meath	20.62	137.71	-16.14
Aviemore	Highland	19.12	143.34	-11.37
Ayr	Ayrshire	20.32	141.85	-13.04
Banff	Aberdeenshire	19.16	144.87	-10.43
Barnstaple	Devon	24.16	140.96	-15.81
Basingstoke	Hampshire	25.22	144.29	-13.92
Bath	Avon	24.61	142.91	-14.61
Belfast	Antrim	20.53	140.27	-14.24
Berwick-Upon-Tweed	Northumberland	20.96	144.86	-11.38
Birmingham	West Midlands	23.84	143.83	-13.57
Blackpool	Lancashire	22.27	143.06	-13.28
Bodmin	Cornwall	24.38	139.98	-16.66
Boston	Lincolnshire	24.10	146.10	-12.12
Bournemouth	Dorset	25.37	143.19	-14.80
Brecon	Powys	23.71	142.02	-14.79
Brighton & Hove	East Sussex	25.95	145.16	-13.65
Bristol	Avon	24.44	142.68	-14.70
Bude	Cornwall	24.17	140.33	-16.29
Burnley	Lancashire	22.59	143.95	-12.84
Bury Saint Edmunds	Suffolk	25.02	146.66	-12.16
Caernarfon	Gwynedd	22.36	141.52	-14.41
Cambridge	Cambridgeshire	24.85	145.97	-12.56
Campbeltown	Argyll & Bute	19.96	140.89	-13.47
Cardiff	Mid Glamorgan	24.19	142.06	-15.01
Cardigan	Ceredigion	23.08	140.69	-15.41
Carlisle	Cumbria	21.40	143.56	-12.48
Carmarthen	Carmarthenshire	23.42	140.98	-15.39
Cavan	Cavan	20.41	138.52	-15.41
Chelmsford	Essex	25.37	146.21	-12.64
Chester	Cheshire	22.86	143.01	-13.63
Colwyn	Clwyd	22.43	142.12	-14.03
Cork	Cork	21.57	136.57	-17.60
Coventry	West Midlands	24.05	144.26	-13.37
Crainlarich	Stirlingshire	19.53	142.26	-12.31
Dingwall	Highland	18.58	142.81	-11.40
Dolgellau	Gwynedd	22.84	141.78	-14.49
Douglas	Isle of Man	21.44	141.64	-13.81
Dover	Kent	26.23	146.91	-12.53
Dublin(Baile Atha Cliath)	Dublin	21.36	139.47	-15.30
Dundee	Angus	20.02	144.02	-11.43
Edinburgh	Midlothian	20.39	143.60	-11.91
Elgin	Grampian	18.91	144.01	-10.83
Exeter	Devon	24.69	141.40	-15.76
Felixstowe	Suffolk	25.51	147.27	-11.96
Fishguard	Dyfed	23.02	140.32	-15.65

Town	County	Elevation	Azimuth	Polarization
Folkestone	Kent	26.24	146.76	-12.64
Fort William	Highland	19.00	141.86	-12.26
Gairloch	Highland	18.08	141.56	-11.90
Galway/Gaillimh	Galway	20.28	136.52	-16.80
Glasgow	Lanarkshire	20.09	142.45	-12.50
Gloucester	Gloucestershire	24.24	143.22	-14.20
Great Yarmouth	Norfolk	25.04	147.96	-11.29
Grimsby	Lincolnshire	23.61	146.25	-11.78
Guildford	Surrey	25.45	144.84	-13.64
Hastings	East Sussex	26.22	146.01	-13.17
Hereford	Hereford and Worcester	23.89	142.79	-14.33
Holyhead	Gwynedd	22.09	141.17	-14.51
Ipswich	Suffolk	25.35	147.08	-12.02
Kendal	Cumbria	21.95	143.56	-12.77
Killarney	Kerry	20.99	135.57	-17.99
Kilmarnock	Ayrshire	20.22	142.13	-12.79
King's Lynn	Norfolk	24.45	146.46	-12.04
Kingston upon Hull	Humberside	23.30	145.98	-11.82
Kyle of Lochalsh	Highland	18.42	141.37	-12.23
Lancaster	Lancashire	22.17	143.40	-12.99
Largs	Ayrshire	19.97	141.80	-12.86
Larne	Antrim	20.35	140.47	-14.00
Leeds	Yorkshire	22.83	144.69	-12.45
Leicester	Leicestershire	24.00	144.74	-13.00
Limerick	Limerick	20.93	136.72	-17.07
Lincoln	Lincolnshire	23.70	145.62	-12.26
Liverpool	Merseyside	22.63	142.99	-13.52
London	Greater London	25.37	145.48	-13.15
Londonderry	Londonderry	19.65	138.93	-14.64
Ludlow	Shropshire	23.63	142.89	-14.12
Luton	Bedfordshire	24.93	145.26	-13.09
Lyme Regis	Dorset	24.92	142.04	-15.41
Maidstone	Kent	25.83	146.07	-12.95
Mallaig	Highland	18.59	141.16	-12.47
Manchester	Greater Manchester	22.87	143.85	-13.05
Middlebrough	North Yorkshire	22.30	145.38	-11.73
Moffat	Dumfries and Galloway	20.85	143.14	-12.46
Montrose	Angus	20.01	144.64	-11.02
Newark upon Trent	Nottinghamshire	23.74	145.24	-12.53
Newcastle upon Tyne	Tyne and Wear	21.78	145.03	-11.69
Newhaven	East Sussex	26.07	145.35	-13.57
Newry	Down	20.70	139.69	-14.75
Newtown	Isle of Wight	25.58	143.72	-14.51
Northampton	Northamptonshire	24.45	144.93	-13.09
Norwich	Norfolk	24.89	147.45	-11.56
Nottingham	Nottinghamshire	23.69	144.81	-12.81
Oban	Argyll & Bute	19.21	141.36	-12.71
Oxford	Oxfordshire	24.75	144.27	-13.71
Peebles	Borders	20.69	143.56	-12.09
Pembroke	Pembrokeshire	23.30	140.27	-15.84
Penrith	Cumbria	21.68	143.70	-12.53
Perth	Perth & Kinross	19.94	143.52	-11.71
Peterborough	Cambridgeshire	24.40	145.70	-12.54
Peterhead	Aberdeenshire	19.54	145.63	-10.16
Pitlochry	Perth & Kinross	19.57	143.31	-11.65

Town	County	Elevation	Azimuth	Polarization
Plymouth	Devon	24.69	140.59	-16.37
Portree	Skye	18.13	140.90	-12.37
Reading	Berkshire	25.10	144.44	-13.76
Rosslare	Wexford	22.20	138.93	-16.21
Scarborough	Yorkshire	22.82	146.12	-11.49
Settle	Yorkshire	22.35	144.00	-12.68
Sevenoaks	Kent	25.70	145.72	-13.13
Sheffield	South Yorkshire	23.22	144.63	-12.70
Shrewsbury	Shropshire	23.32	143.02	-13.87
Sligo	Sligo	19.74	137.48	-15.74
Southampton	Hampshire	25.40	143.80	-14.37
Stafford	Staffordshire	23.49	143.74	-13.45
Stirling	Stirlingshire	19.99	142.84	-12.18
Stoke on Trent	Staffordshire	23.28	143.71	-13.36
Stranraer	Dumfries and Galloway	20.61	141.31	-13.56
Stratford-upon-Avon	Warwickshire	24.18	143.95	-13.65
Swansea (Abertawe)	Swansea	23.76	141.28	-15.35
Swindon	Wiltshire	24.24	143.41	-14.06
Tain	Highland	18.54	143.28	-11.08
Thirsk	North Yorkshire	22.55	145.07	-12.06
Thurso	Highland	18.05	144.11	-10.28
Torquay	Devon	24.92	141.31	-15.96
Tralee (Tra Li)	Kerry	20.73	135.45	-17.92
Truro	Cornwall	24.40	139.56	-17.00
Uig	Skye	17.20	140.31	-12.17
Ullapool	Highland	18.08	142.14	-11.54
Waterford	Waterford	21.90	138.12	-16.62
Watford	Hertfordshire	25.13	145.20	-13.24
Westport	Mayo	19.65	136.21	-16.62
Weymouth	Dorset	25.22	142.51	-15.22
Wick	Highland	18.32	144.51	-10.19
Worcester	Hereford and Worcester	23.97	143.38	-13.95
Workington	Cumbria	21.37	142.79	-12.98
Yeovil	Somerset	24.86	142.45	-15.08
York	North Yorkshire	22.88	145.25	-12.10



For further information, please contact:

Customer Careline: 0901 293 0038.

Calls are charged at £1 per minute from a BT landline.

Call charges from other networks may vary.

Technical Support: <http://technical.philex.com>



Waste electrical and electronic products must not be disposed of with household waste. Please recycle where facilities exist. Check with your Local Authority for recycling advice.