

BASKETBALL SHOT TRAINER



iC3 Assembly Instructions

To assemble, two 10mm wrenches required. *(not included)*



X2

A division of **AIRBORNE**
ATHLETICS
Innovate Your Game!

SAVE THESE IMPORTANT SAFETY INSTRUCTIONS

DANGER

Install the Product only to a basketball system with a break-away rim with proper Pole Support in use. See pole support details on page 7.

You must ensure your basketball net or hoop is properly balanced. If your basketball net or hoop uses a reservoir for balance, use at least 30 lbs of additional weight to counterbalance the weight this product adds to your basketball system.

Do not attempt to move, adjust height or collapse basketball backboard system while the Product is installed on the rim.

Because this Product hangs down from your basketball backboard and hoop it may create a height hazard for players, spectators, bystanders, or vehicles. Make sure there is adequate clearance on all sides of this Product. Use caution when walking, running, or jumping under or around this Product.

Because this Product contains metallic parts, NEVER play basketball, or stand near this Product, during a storm or if you notice thunder or lightning.

WARNING

To reduce the risk of serious injury, read all important precautions and instructions in this manual and all warnings on your Product before use. It is the responsibility of the owner to ensure that all users of this Product are adequately informed of all warnings and precautions. Use the product only as described in this manual. Airborne Athletics assumes no responsibility for personal injury or property damage sustained by or through the use of this Product.

Playing basketball, or training in the sport of basketball, is exercise. How you begin your exercise program depends on your physical condition. Before beginning any exercise program, consult your physician. This is especially important for persons over age 35 or persons with pre-existing health problems. Frequent and strenuous exercise should be approved by your doctor first.

Warming up is an important part of your workout, and should begin every session. It prepares your body for more strenuous exercise by heating up and stretching out your muscles, increasing your circulation and pulse rate, and delivering more oxygen to your muscles. At the end of your workout, repeat the warm up exercises to reduce sore muscle problems.

If any discomfort should result from your use of this Product, stop exercis-

ing and consult your doctor. While performing any type of exercise routine you must drink plenty of fluids. You must replace the water lost from exercising to avoid dehydration. Avoid drinking large amounts of cold liquids. Fluids should be at room temperature when consumed. It's important to work at your own pace.

Please keep all children away from the Product when Product is unattended. Adult supervision is required at all times during use of this Product.

Please ensure this product is assembled and installed by adults. Do not attempt to move, install, or remove this Product alone. Each adult must be able to safely lift 25 lbs overhead to install and remove the Product.

Properly remove and store this Product when not in use.

Proper maintenance is very important to ensure your Product is always in top working condition. Inspect and properly tighten all parts of the Product regularly. Make sure that all bolts and nuts are tightened when the Product is in use. Improper maintenance could cause damage or shorten the life of your Product and exceed the LIMITED WARRANTY coverage.

LIMITED WARRANTY

Airborne Athletics, Inc. (Airborne) warrants this Product to be free from defects in workmanship and material, under normal use and service conditions, for a period of six (6) months from the date of purchase. During this period, Airborne will repair or replace any defective part. Airborne's warranty applies to repaired or replaced Products for the balance of the applicable period of the original warranty or ninety (90) days from the date of shipment of a repaired or replaced Product, whichever is longer. All repairs for which warranty claims are made must be pre-authorized by Airborne. No other warranty beyond that specifically set forth above is authorized by Airborne.

EXCLUSIONS and LIMITATIONS

This warranty does not apply to your Airborne product unless it was purchased directly from Airborne or an authorized Airborne distributor or reseller.

This warranty does not apply to any defects caused by abuse, negligence, misuse, improper assembly or maintenance, freight damage, accident, or an "act of god".

This warranty does not apply to discoloration of paint, plastics or fabrics.

Airborne Athletics shall not be responsible for incidental or consequential damages.

This warranty is nontransferable from the original owner.

REGISTRATION

You must register your Airborne product before a warranty claim can be processed. To complete your registration, go to airborneathletics.com and fill out the registration online. Product Warranties are not valid unless properly completed within 30 days of purchase.

INDEMNIFICATION

As a condition of use of this Product, you agree to indemnify, defend, and hold harmless Airborne, its officers, directors, employees, agents, licensors and suppliers (collectively the "Service Providers") from and against any and all losses, expenses, damages and costs, including reasonable attorneys' fees, resulting from your use of this Product, including any claims alleging facts that if true would constitute a violation of these terms or any activity related to your Product (including negligent or wrongful conduct) by you or any other person using your Product.

OTHER

These terms shall be governed by and construed in accordance with the laws of the state of Minnesota, U.S.A., without giving effect to any principles of conflicts of law, and expressly not by the United Nations Convention on Contracts for the International Sales of Goods. You agree that any action at law or in equity arising out of or relating to these terms shall be filed only in the state or federal courts located in Hennepin County Minnesota and you hereby consent and submit to the personal jurisdiction of such courts. If any provision of these terms shall be unlawful, void, or for any reason unenforceable, that provision shall be deemed severable from these terms and shall not affect the validity and enforceability of any remaining provisions. Airborne's failure to insist upon or enforce strict performance of any provision of these terms shall not be construed as a waiver of any provision or right. This is the entire agreement between us relating to the subject matter herein and shall not be modified except as described herein.



Part Table and Diagram

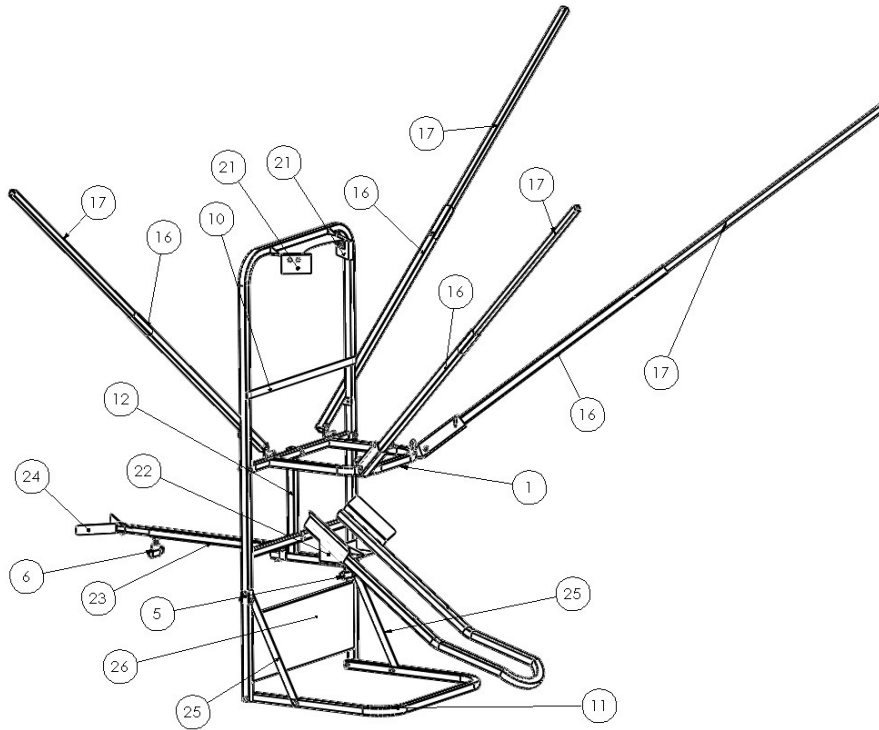

Part #	Description	Qty.
1	Horizontal frame	1
2a	Short pole brace	1
2b	Medium pole brace	1
2c	Long pole brace	1
3	Net*	1
4	Rubber washer	1
5	Female T handle	1
6	Male T handle	1
7	Ball detent pin	2
8	M6x1 Lock nut*	23
9	M6x35mm bolt*	7
10	Vertical frame	1
11	Lower brace	1
12	L Bracket	1
13	M6x25mm bolt*	6
14	M6x45mm bolt*	4
15	M6x30mm bolt*	6
16	Outside net poles	4
17	Inside net poles	4
18	Carabineers	4
20	Pop pins	4
21	Rim rest	2
22	Ball ramp	1
23	Main pole support	1
24	Pole support brace	1
25	Gusset	2
26	Lower frame	1
27	Short Velcro*	6
28	Long Velcro*	4

#10 Vertical Frame

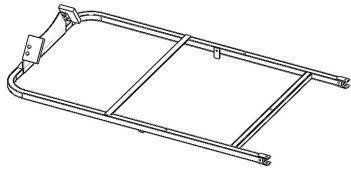

#22 Ball Ramp

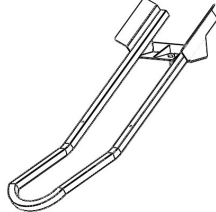

#12 L-Bracket

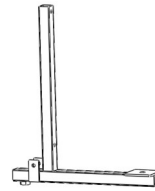

#16 Outside Net Pole



#17 Inside Net Pole



#25 Gusset

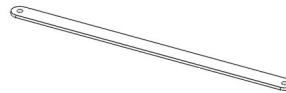

* Not Shown

Pole Braces
(Not Shown)

#2A



#2B

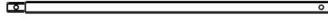

#2C



#26 Lower Frame

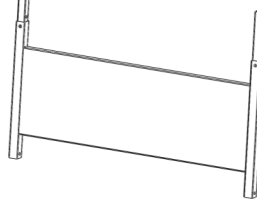

#1 Horizontal Frame

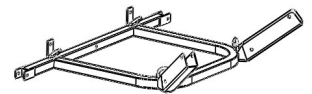

#20 Pop Pin
(Not Shown)



#11 Lower Brace

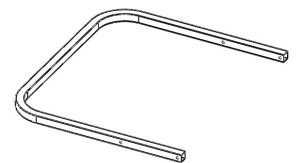

#24 Pole Support Brace



#23 Main Pole Support



#18 Carabineer
(Not Shown)

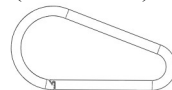

#7 Ball Detent Pin
(Not Shown)



#21 Rim Rest



#6 Male T-Handle



#5 Female T-Handle



#4 Rubber Washer
(Not Shown)

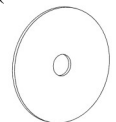



Step 1: Lower Frame, Brace and Gussets

- A: Fasten the Vertical frame (10) to the lower frame (26) using two M6x35 bolts (9). Secure with lock nuts (8).
- B: Fasten the Lower brace (11) to the lower frame (26). Using two M6x45 bolts (14). Secure with lock nuts (8).
- C: Fasten the Gussets (25) to inside of the vertical frame (10) and the outside of the lower brace (11) using four M6x30 bolts (15). Secure with lock nuts (8).

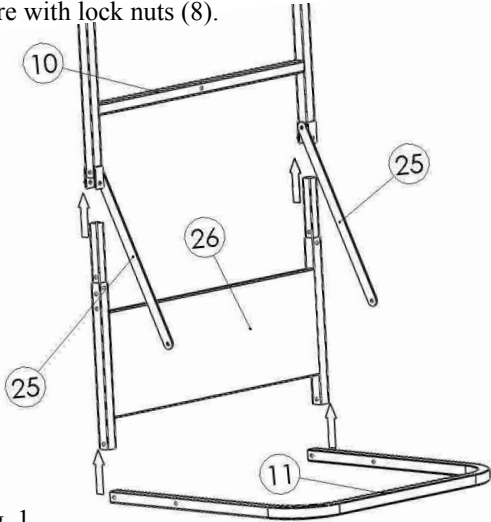
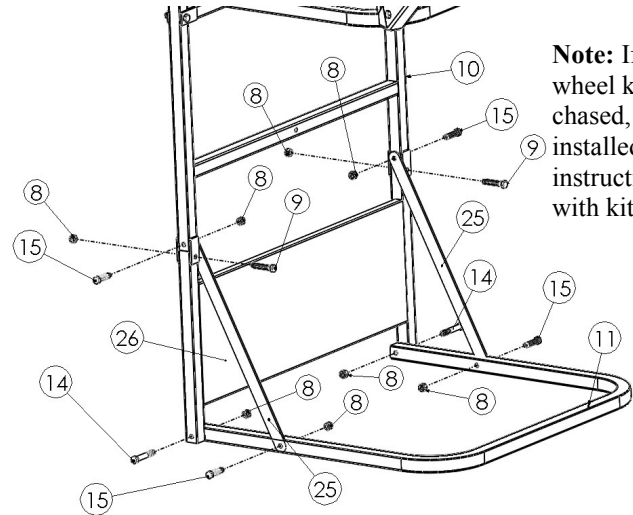

Fig. 1



Note: If optional wheel kit was purchased, it should be installed now; using instructions supplied with kit.

Fig. 2

Step 2: Horizontal Frame and Rim Rests

- A: Insert Horizontal frame (1) inside of Vertical frame (10). Rotate Horizontal frame until the holes line up with the holes in the Vertical frame.
 - B: Fasten the Horizontal frame (1) to the Vertical frame (10) Using two M6x35 bolts (9) . Secure with Lock nuts (8).
 - C: Fasten both Rim Rests (21) to vertical frame (10) using four M6x25 bolts (13). Secure with Lock Nuts (8).
- Note:** Rim Rests (21) have a short side and a long side. (The distance from the edge to the center of the hole.) The long side must face toward the rim when in use. See figure 4.5

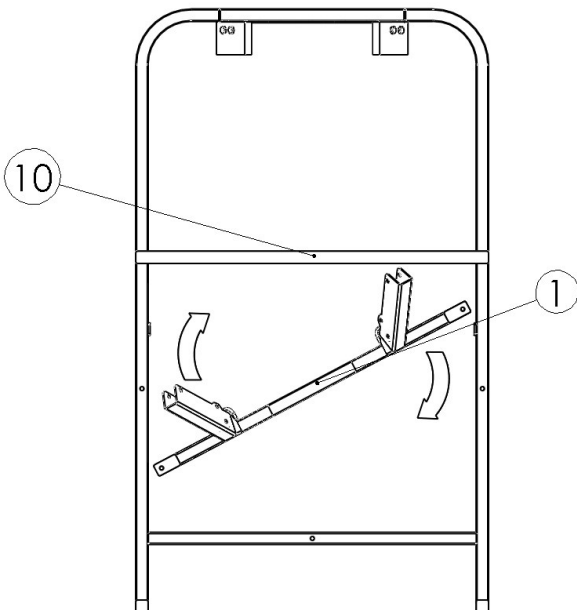

Fig. 3

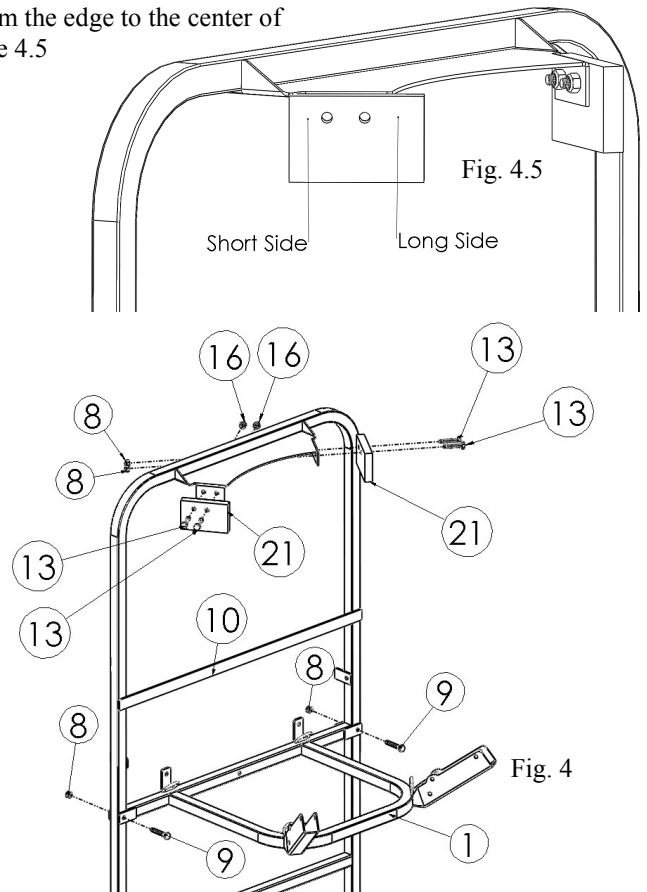

Fig. 4

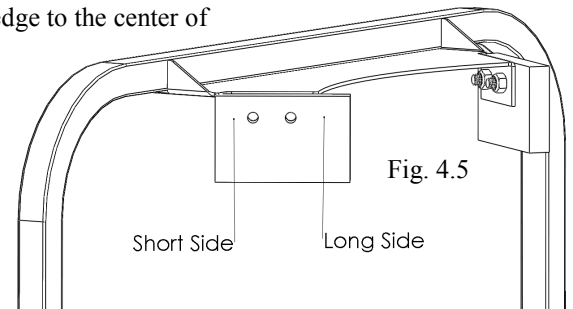

Fig. 4.5



Step 3: L-Bracket

A: Fasten the lower hole on the L-bracket (12) to the vertical frame (10) using a M6x45 bolt (14).
Fasten the upper hole on the L-bracket (12) to the Horizontal frame (1) using a M6x45 bolt (14). Secure both with lock nuts (8).

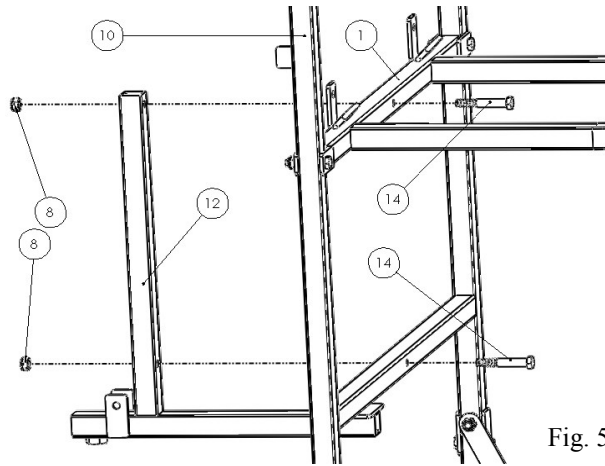

Fig. 5

Step 4: Installing Net Poles

Front Poles:

A: Fasten Outside net poles (16) to Horizontal frame (1) using M6x35 bolt (9). Secure with lock nut (8). Do not fasten snug. Net poles must be able to pivot for storage.
B: Insert removable ball detent pin (7) in horizontal frame (1).

Note: Before installing poles make sure top hole is orientated inward.

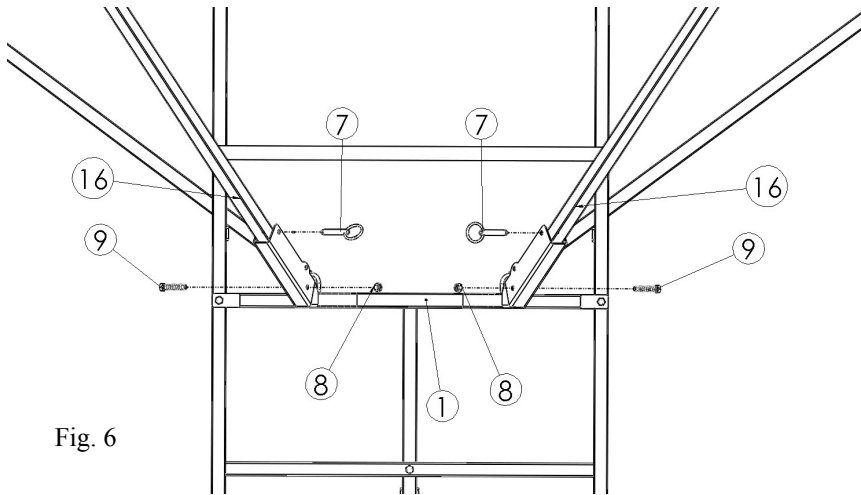

Fig. 6

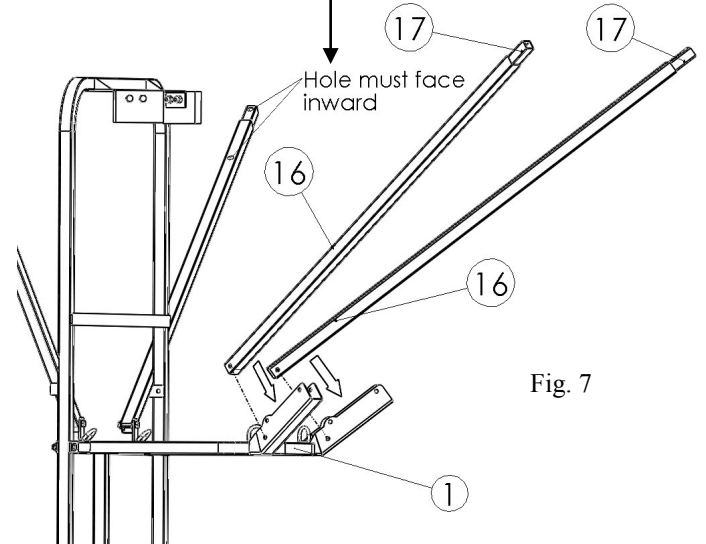

Fig. 7

Note: Pull Inside net pole (17) out slightly so it isn't blocking the holes in the Outside net poles (16) to insert the bolt through.

Rear Poles: Allow rear poles to rest on pole guides. Fasten Outside net pole (16) to Horizontal frame (1) using M6x30 bolt (15). Secure with lock nut (8). Do not fasten snug. Net poles must be able to pivot for storage.

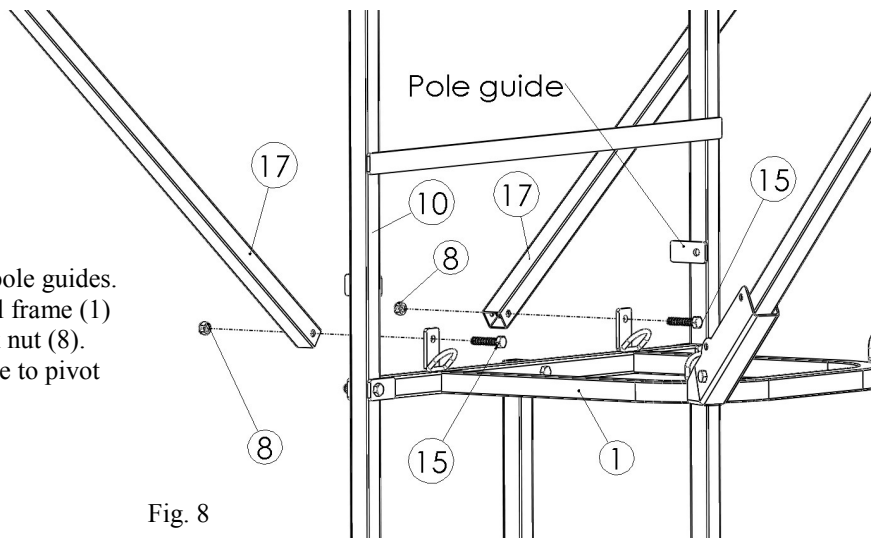

Fig. 8



Step 5: Ball Ramp

A: Install Ball ramp (22) through hole in L-bracket (12) using rubber washer (4) between them. Tighten down using female T-handle (5).

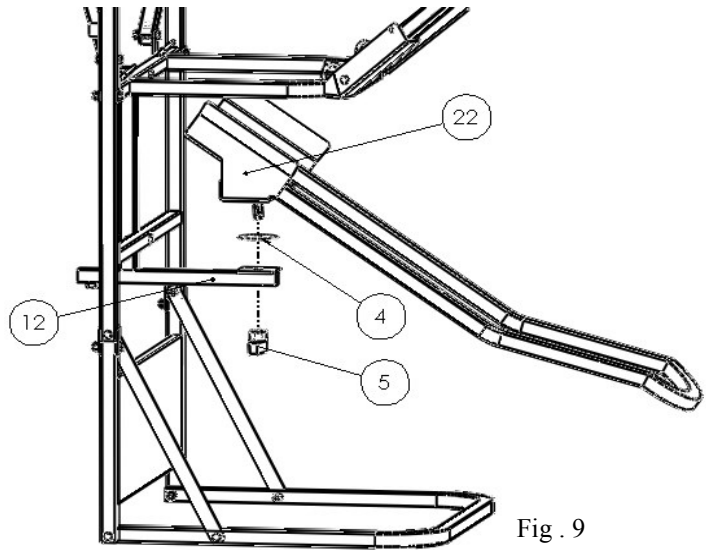

Fig . 9

Step 6: Installing Net Velcro

- A: Lay out net (3) on a flat surface with the black ribbon facing down.
- B: Loop Long Velcro (28) to the bottom four corners. See figure 10.
- C: Loop two of the short Velcro (27) 11 squares up from the bottom on the center net panel.
- D: Loop Short Velcro (27) 12 squares up from the bottom on the left and right side.
- E: Loop Short Velcro (27) 13 squares down from the top on the left and right side.

Note: Velcro placement is adjustable. Velcro straps can be moved if necessary.

Note: Soft side of Velcro should face out.

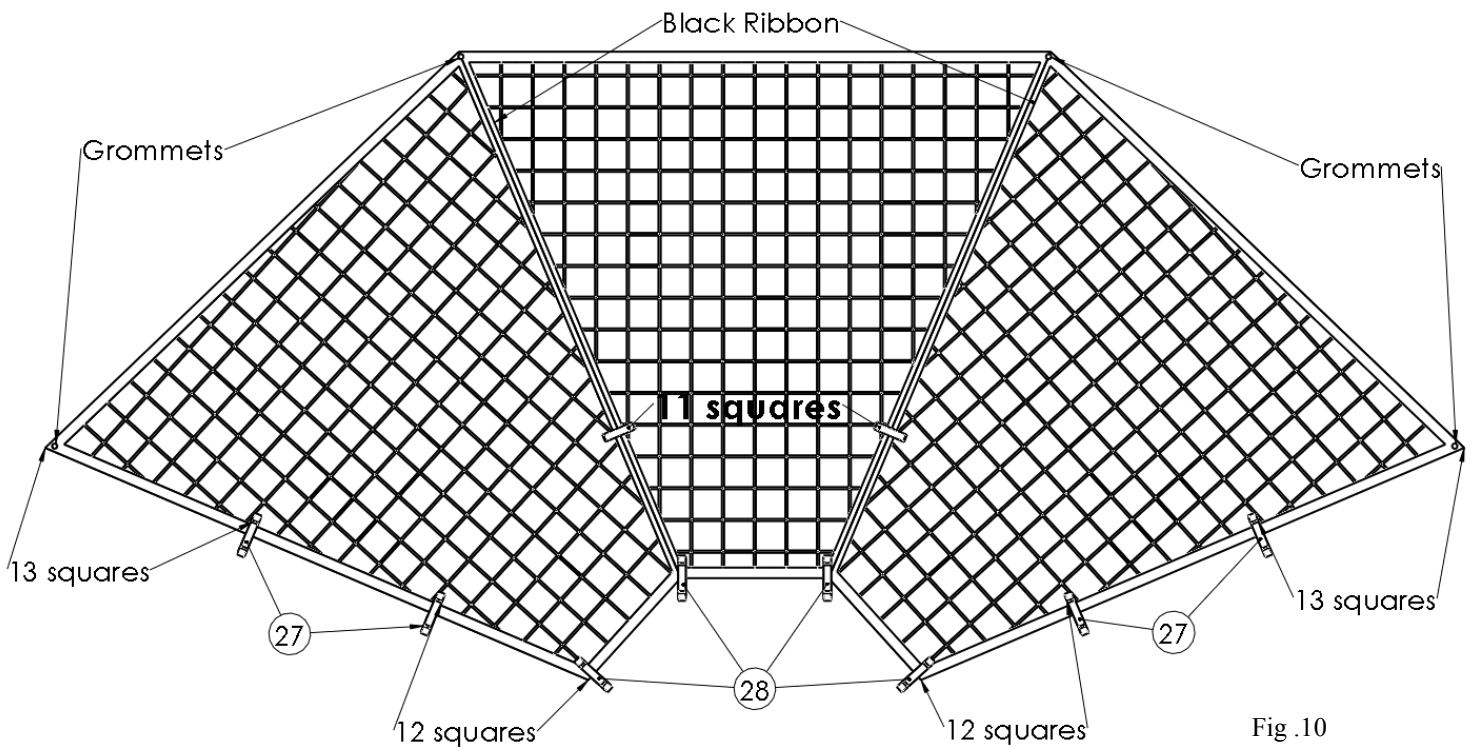

Fig .10



Step 7: Attach Net

A: Slide Inside net pole (17) out of Outside net pole (16) until the silver button on the pop pin (20) securely pops out of the hole in the outside net pole (16). Repeat on the other three poles.

B: Attach Carabineer (18) to grommet holes in Net (3) and hole in the Inside net pole (17). Repeat on other three Inside net poles (17). See figure 11. Carabineer (18) latch should face up. See figure 11.5

C: Attach Velcro (28) on Net (3) to corresponding D ring on Horizontal frame (1). Repeat on other three D rings. See figure 13.

D: Attach Velcro (27) on Net (3) to Outside net poles (16). Repeat once on the other front net pole and four times on the two rear net poles. See figure 12.

Note: Install Carabineer (18) with latch facing up

Fig. 11.5

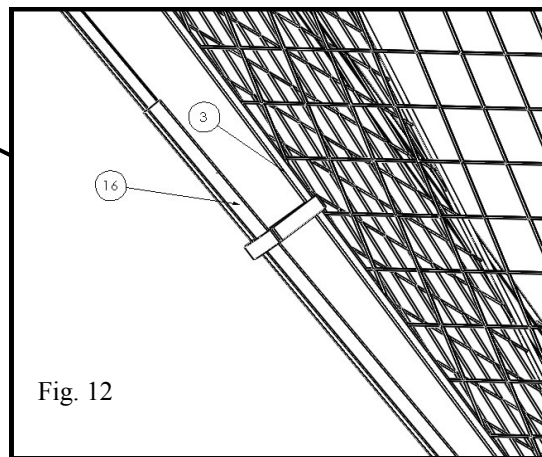
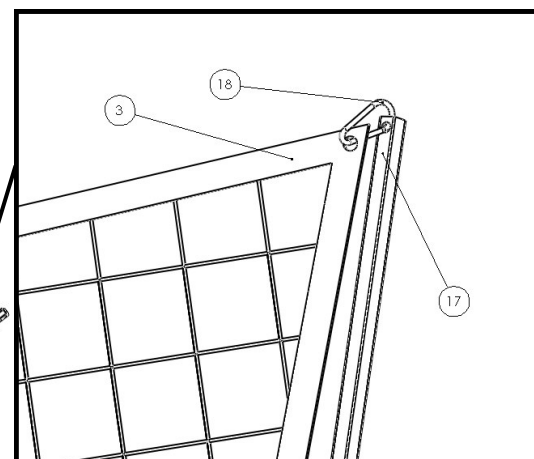
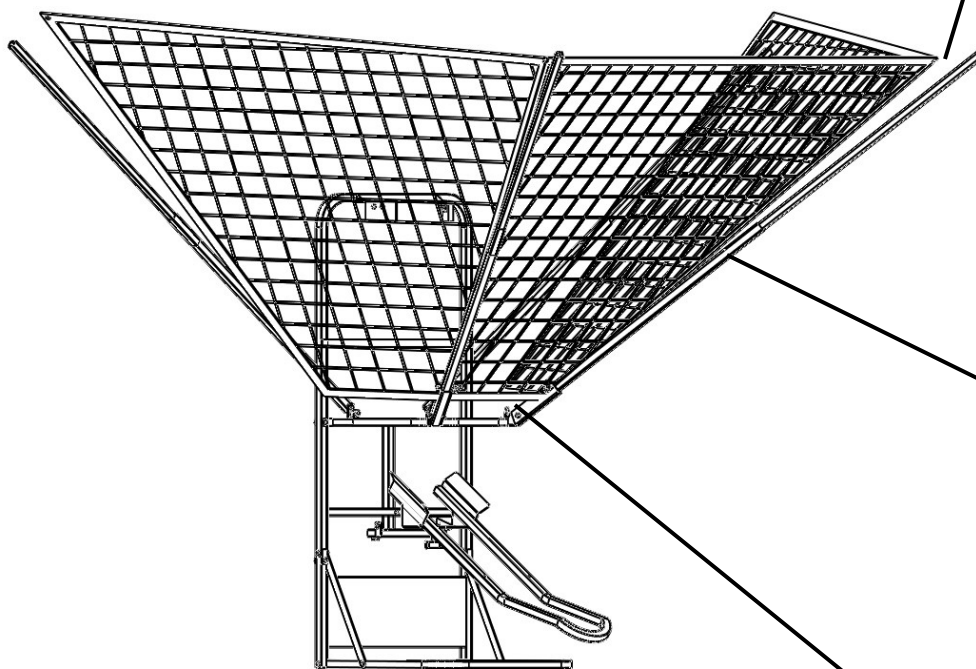
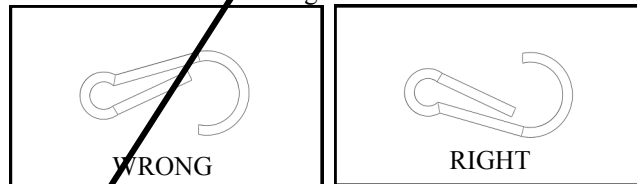

Fig. 12

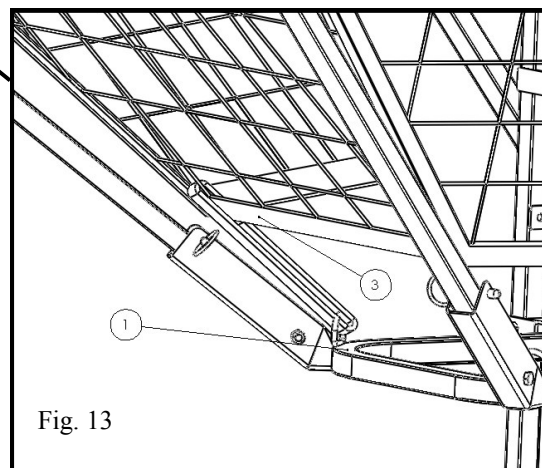

Fig. 13

Note: Velcro (27) should pull the net (3) tight to the front Outside net poles (16). The rear net poles should not pull the net tight to net poles.

Note: Make sure black ribbon faces towards net poles when orienting the net for installation.

Note: If using on a regulation 72 inch backboard with a pad, assembly is complete. If using on a pole-supported unit continue to step 7.



Step 8: Backboard to pole overhang 18" or less

- A: Measure distance between the front of your backboard and your pole to determine which pole brace fits your needs.
- B: If distance is greater than 18" go to step 9.
- C: If Distance is 0" to 10.5", install short pole brace (2A) into pole support brace (24). Fasten using M6x25 bolt (13). Secure with lock nut (8). See figure 15 and 16.
- D: If distance is 10.5" to 18", repeat step C using Medium pole brace (2B).
- E: Install completed brace into Bottom support tube. Thread Male T-handle into L-bracket (12). See figure 17.

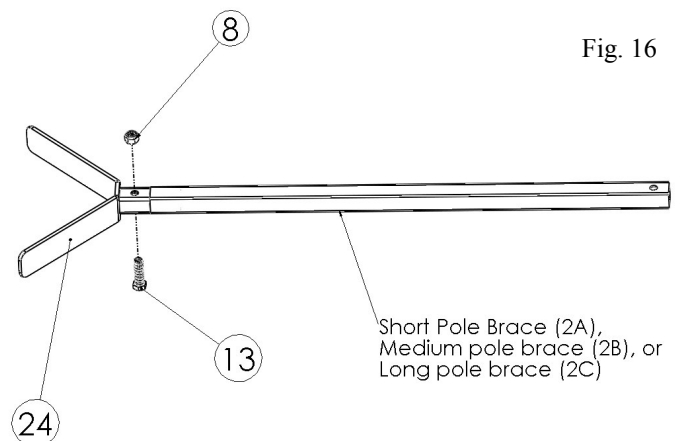
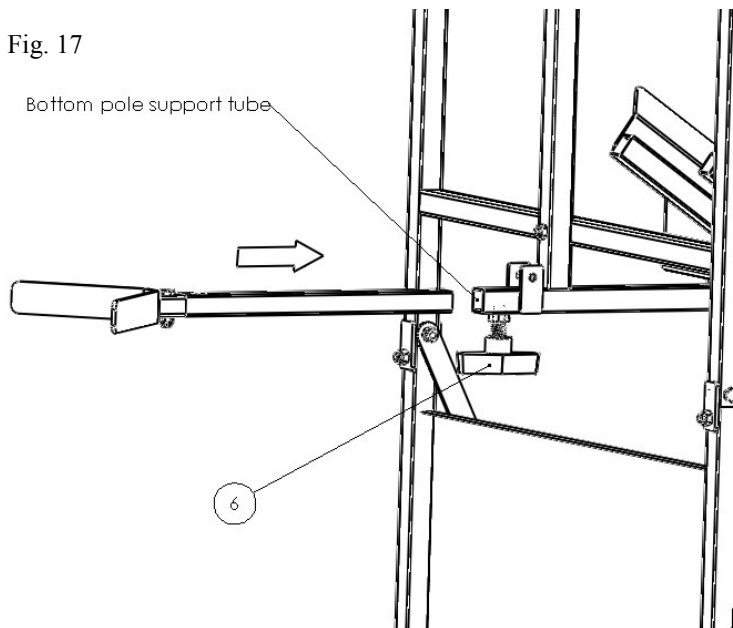
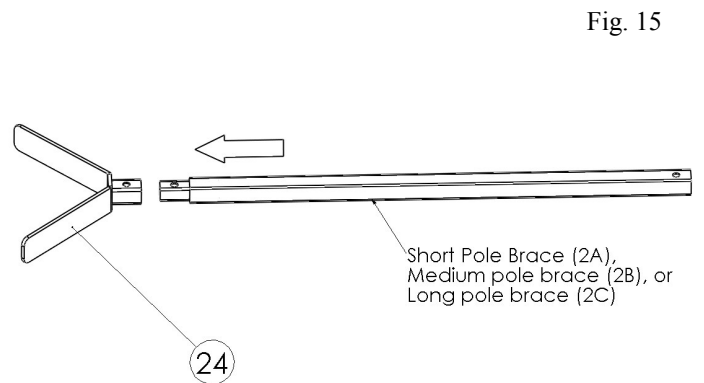
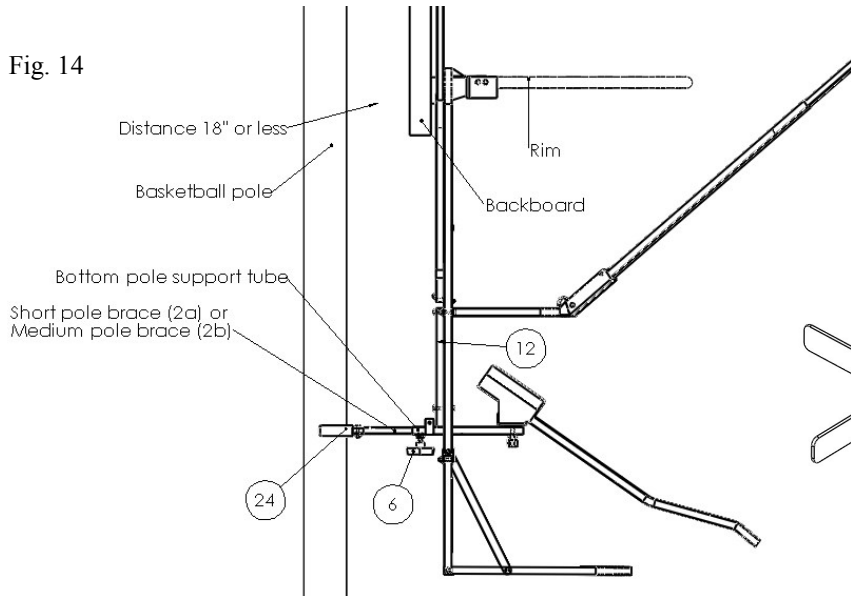



Step 9: Backboard to pole overhang 18" or more

- A: Slide Main pole support (23) between tabs on L-bracket (12) until hole lines up. See figure 19.
- B: Fasten Main pole support (23) to L-bracket (12) using M6x35 bolt (9). Secure with Lock nut (8). See figure 18.
- C: Thread Male T-handle (6) into Main pole support (23). See figure 18.

Note: Tighten bolt on Main pole support (23) tight enough so that it will stay in the up position on its own when in the storage position. (See storage section of manual page 10.)

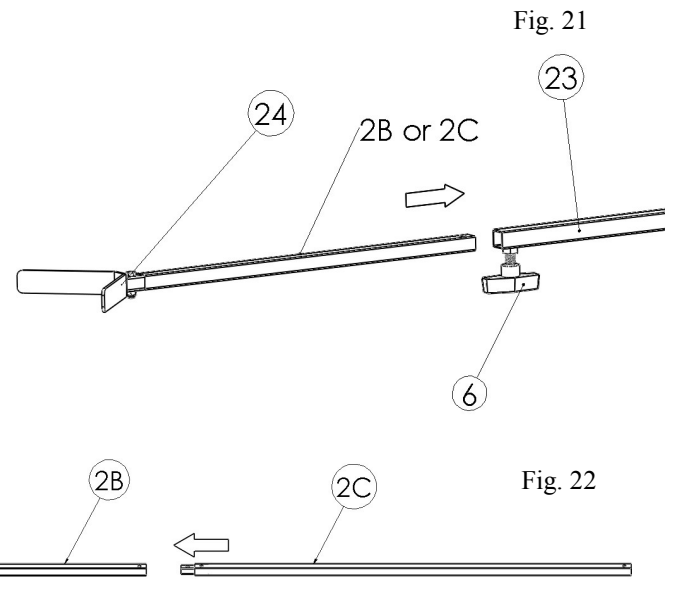
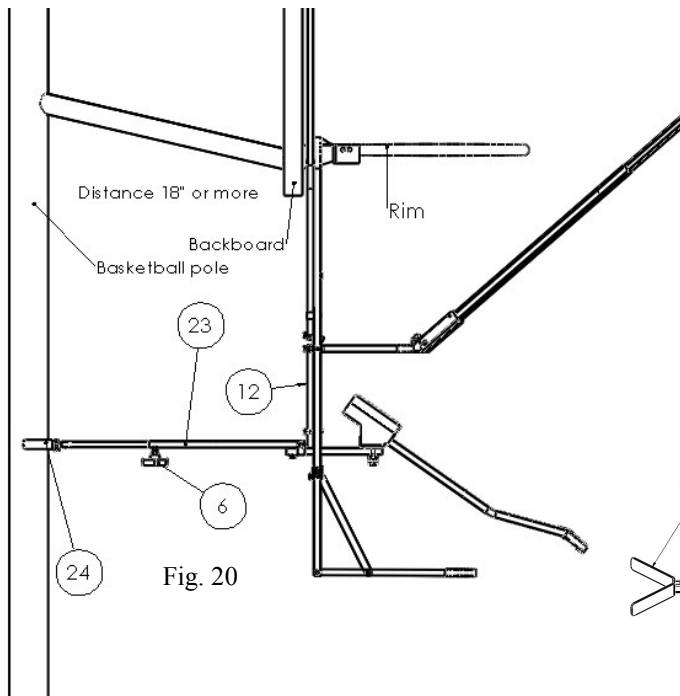
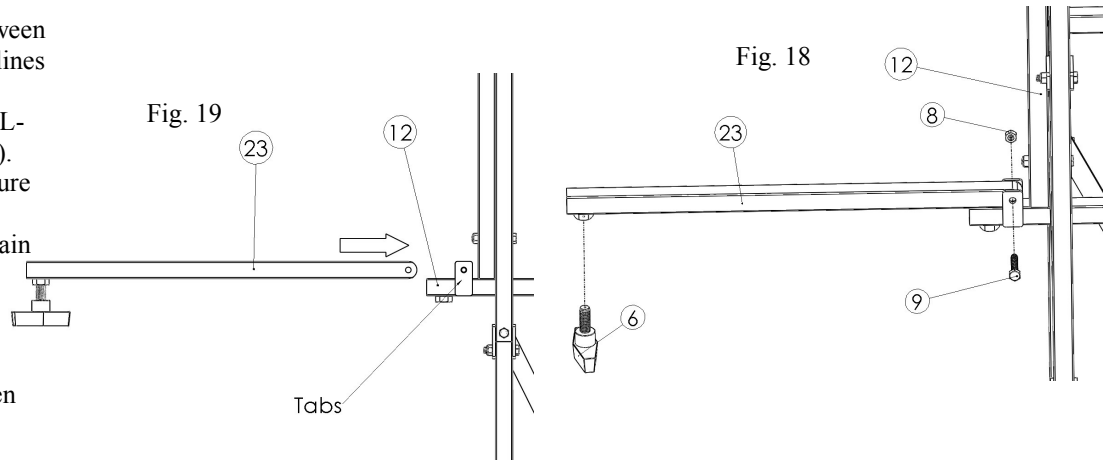

- D: If distance is 18" to 33" install Medium pole brace (2B) to Pole support brace (24). See Figure 15 and 16 on page 8.
- E: Slide completed brace into Main pole support (23), See figure 21. Then tighten male T handle (6).
- F: If distance is 33" to 48", repeat Step D using Long pole brace (2C).
- G: If distance is 48" to 65", follow step D. Then install Long pole brace (2C) into Medium Pole Brace (2B) using M6x25 bolt (13). Secure with lock nut (8). See figure 22 and 23. Then repeat Step E.

Quick Reference Guide

Distance from Backboard to pole	Pole Brace used
0" - 10.5"	2A
10.5" - 18"	2B
18" - 33"	2B + Part 23
33" - 48"	2C + Part 23
48" +	2B + 2C + Part 23

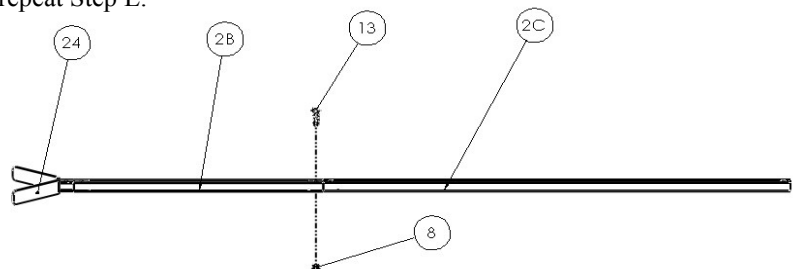



Storage, Specifications, and Troubleshooting

Storage:

- A: Slide all four Inside net poles (17) down by pressing on the Pop Pins (20) (not shown)
- B: Remove ball detent pin (7) from horizontal frame (1).
- C: Fold net pole poles in.
- D: Fold up Main pole support (23).
- E: Remove Female T-handle (5) from Ball ramp (22).
- F: Remove ball ramp (22) from L-Bracket (12). Flip around and place over net poles.
- G: Reinstall Ball detent pins (7) in storage hole, see figure 25.
- H: Reinstall Female T-handle.

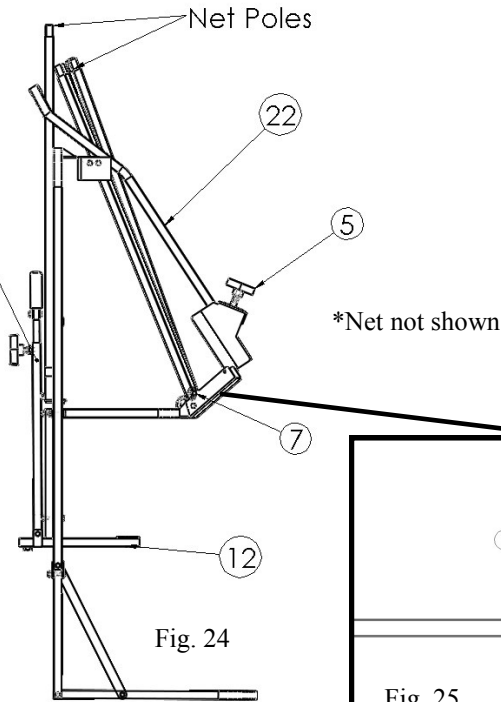

Specifications:

- Weight: 35lbs (15.8kg)
- Storage Dimensions:
- Length 22" (56cm)
- Width 22" (56cm)
- Height 59" (150cm)

Troubleshooting:

- After extensive use, the net may loosen.
- To tighten net:
- Release Velcro holding bottom of net to Horizontal frame. Pull down net so it is tight and loop Velcro back around net. (See figure 13 on page 7.)

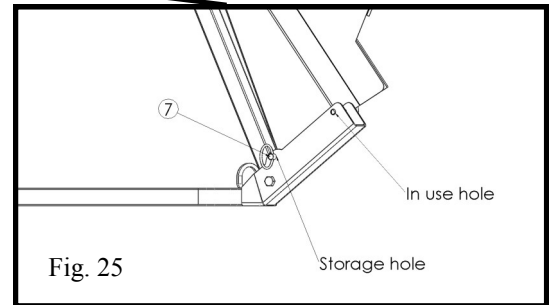

How to Safely Lift iC3

Two people are recommended to safely mount the iC3. Person A lifts the right side and Person B lifts the left side. Firmly grip the lower brace with one hand and the vertical frame with the other hand in area's shown by arrows (see figure 26) and lift the iC3 keeping it level.

(See page 11 for mounting to rim.)

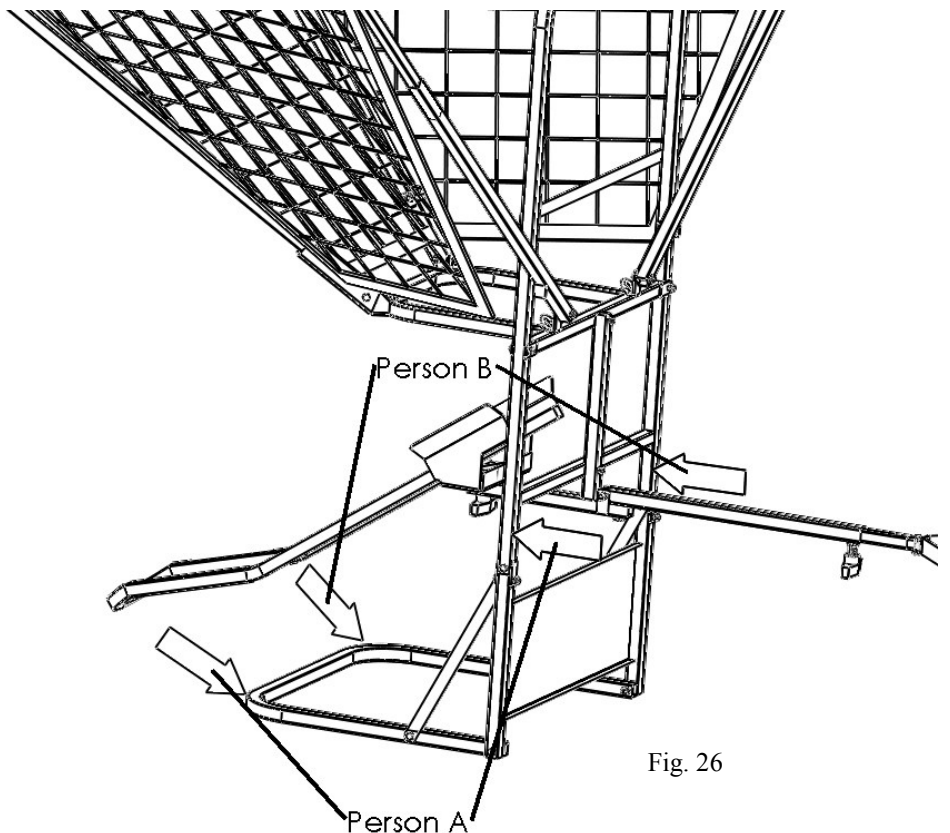



Mounting for Use

A: Lift the unit high enough so that the top of the Vertical frame (10) goes up and over the top of the basketball hoop. Set the unit down so that the Rim Rests (21) rest against the rim. See figure 28.

B: Using the pole brace/support decided upon in steps 8 and 9, level the unit on the rim and extend the pole brace against the basketball pole. Tighten Male T-handle to secure it in place. (Omit this step if using on a non-pole supported unit with a regulation 72" backboard.)

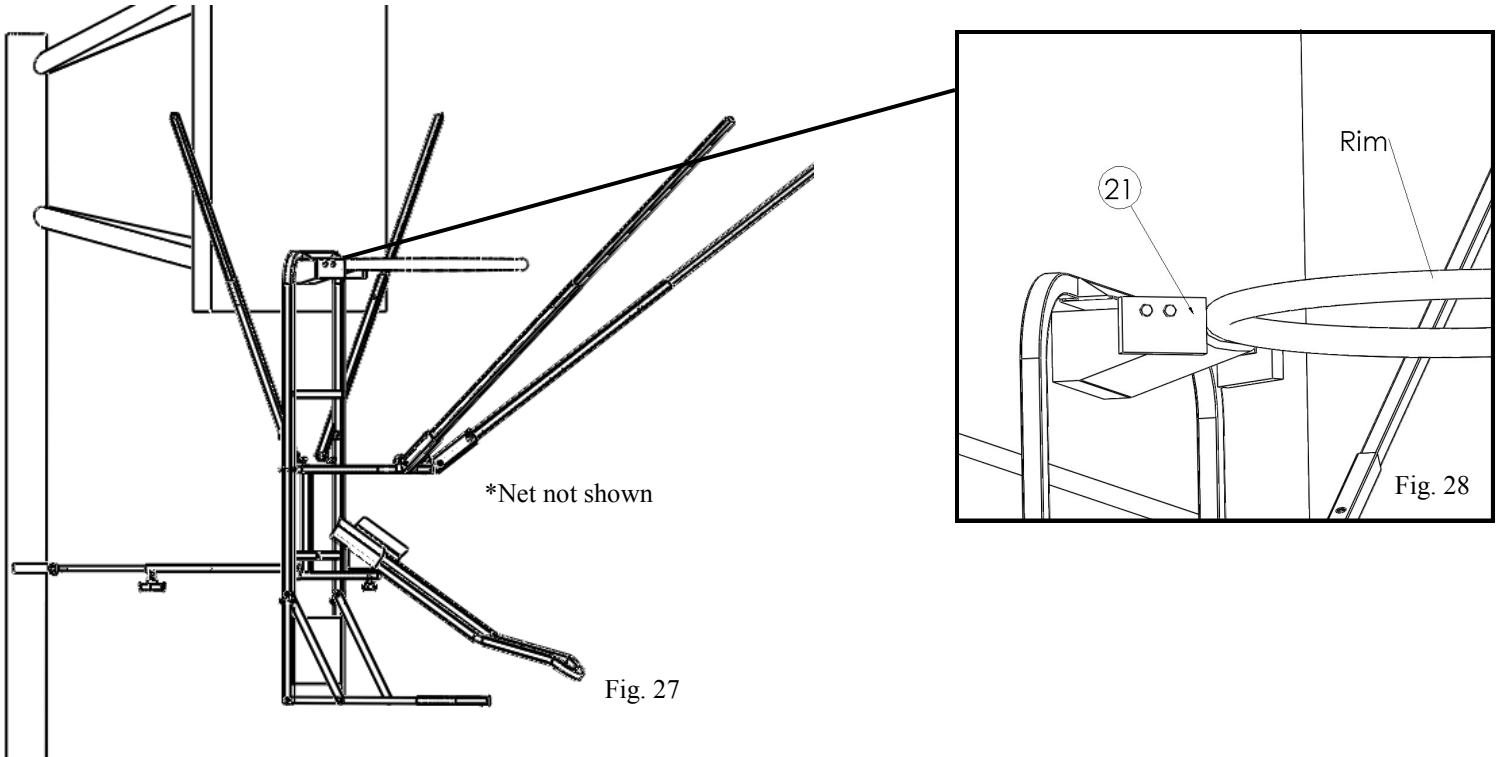

Rotating Ramp

Ramp can rotate 180 degrees.

To rotate ramp:

Loosen Female T-Handle (5) by a full turn. Rotate Ball ramp (22) to desired location and retighten T-Handle.

Tighten T-handle by hand only.

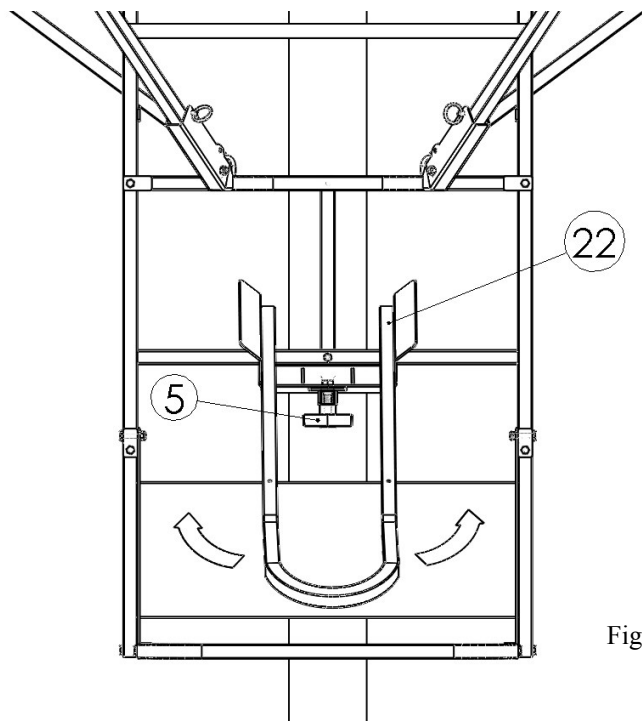

CUSTOMER SERVICE

REGISTRATION AND WARRANTY

Please register your iC3 Basketball Shot Trainer with Airborne Athletics before a warranty claim can be processed. See page 2 for full warranty information. To complete your registration and activate your warranty coverage, go to airborneathletics.com and fill out the registration form online.

QUESTIONS OR CONCERNS?

Please do not hesitate to contact us with any questions or concerns related to your iC3 Basketball Shot Trainer purchase. Call 888-887-7453 or send us an email at info@airborneathletics.com, we are always happy to help.



BASKETBALL SHOT TRAINER

CONNECT WITH AIRBORNE ATHLETICS

Tell us what you think of the iC3 Basketball Shot Trainer and be entered into our monthly gift card prize drawing! Post your comments, pictures or videos to our social web pages and be entered to win.



@myiC3 |



/airborneathletics

iC3 SHOT TRAINING DRILLS

Now that you have the iC3 Basketball Shot Trainer installed, get started with drills! Need ideas - log onto airborneathletics.com and view drills posted online.

OPTIONAL ACCESSORIES

For pricing and ordering information, please go to airborneathletics.com.

Wheel Kit Package: Add on wheels to make your iC3 easier to move from storage to the basketball hoop.

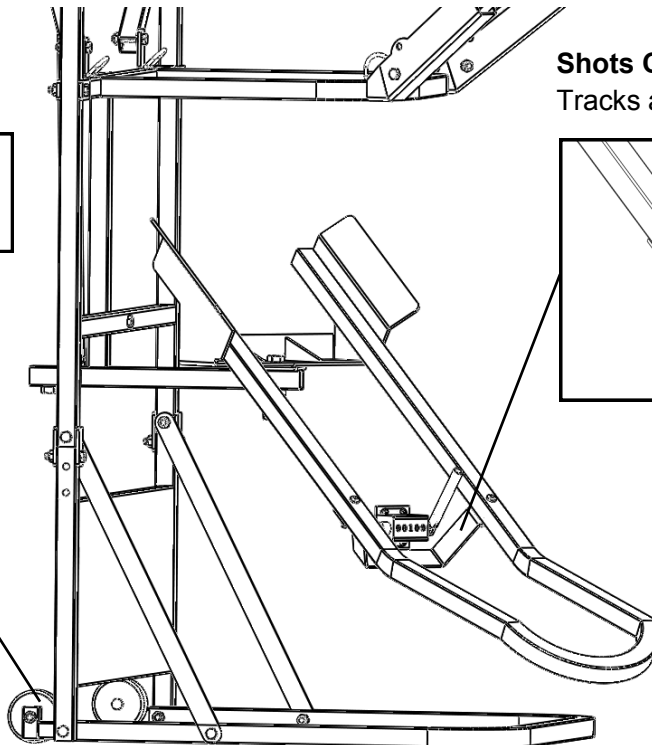

Shots Counter:

Tracks all shots taken per workout.

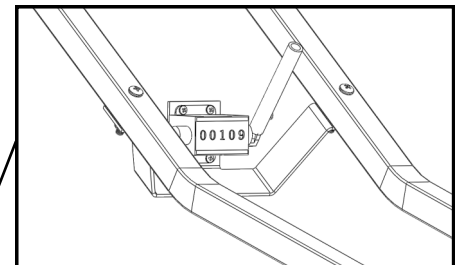

A division of **AIRBORNE**
ATHLETICS
Innovate Your Game!