

Owner's Manual & Assembly Instructions

ST01

Model No. **WH1014-D1**

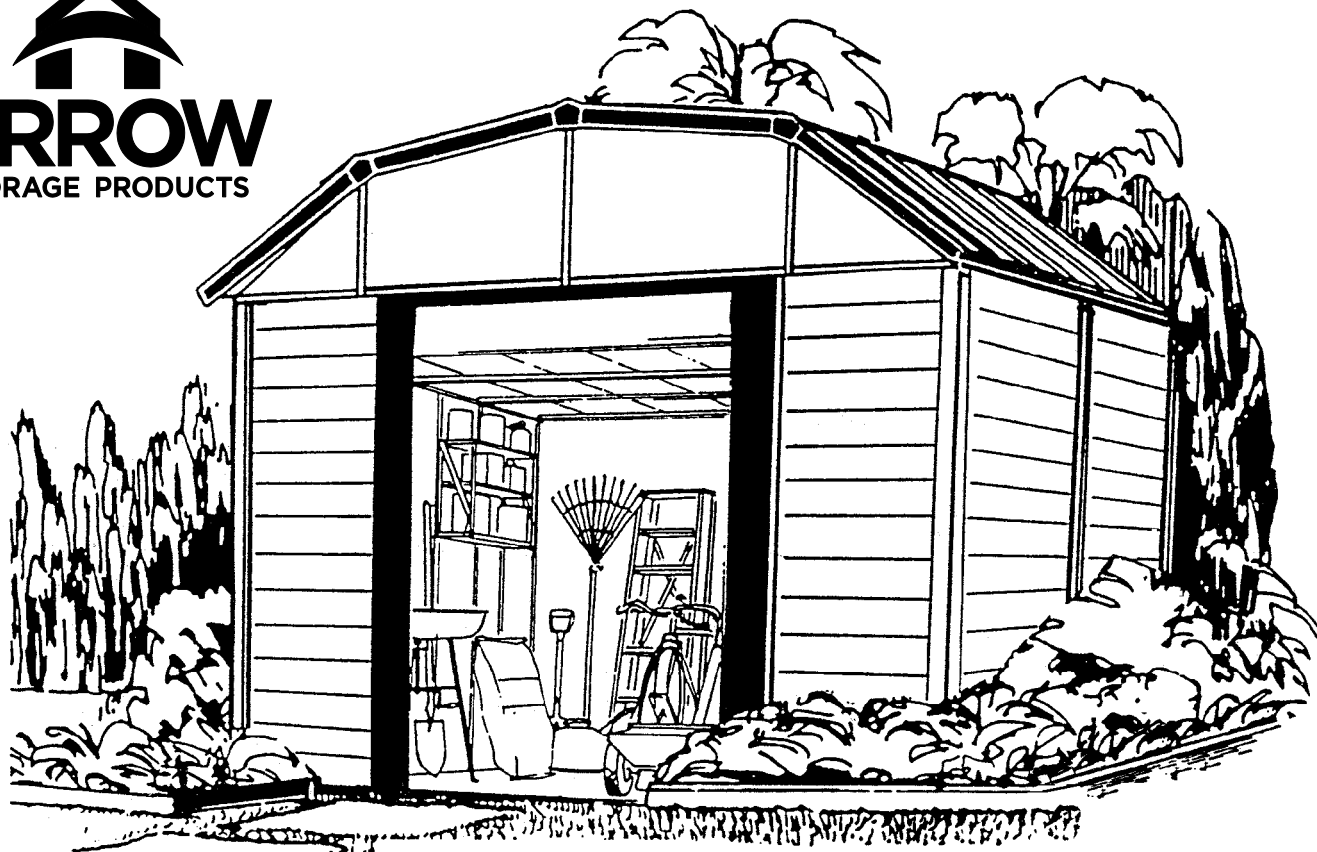

Missing Parts, Questions on Assembly?

Call: 1-800-851-1085 or assist@arrow-sheds.com

Do not return to dealer, they are not equipped to handle your requests.

714890716

Storage Area: 129 Sq. Ft. 852 Cu. Ft.
12,0 m² 24,1 m³



CAUTION: SOME PARTS HAVE SHARP EDGES. CARE MUST BE TAKEN WHEN HANDLING THE VARIOUS PIECES TO AVOID A MISHAP. FOR SAFETY SAKE, PLEASE READ SAFETY INFORMATION PROVIDED IN THIS MANUAL BEFORE BEGINNING CONSTRUCTION. WEAR GLOVES WHEN HANDLING METAL PARTS.

BUILDING DIMENSIONS * Size rounded off to the nearest foot

*Approx. Size	Base Size	Exterior Dimensions (Roof Edge to Roof Edge)			Interior Dimensions (Wall to Wall)			Door Opening	
		Width	Depth	Height	Width	Depth	Height	Width	Height
10' x 14'	121" x 160 1/4"	123 1/4"	162 3/4"	87 7/8"	118 1/4"	157 1/2"	86 5/8"	55 1/2"	60"
3,0 m x 4,0 m	307,3 cm x 407,0 cm	313,1 cm	413,4 cm	223,2 cm	300,4 cm	400,1 cm	220,0 cm	141,0 cm	152,4 cm

BEFORE YOU BEGIN...

A03

Owner's Manual

Before beginning construction, check local building codes regarding footings, location and other requirements. Study and understand this owner's manual.

Important information and helpful tips will make your construction easier and more enjoyable.

Assembly Instructions: Instructions are supplied in this manual and contain all appropriate information for your building model. Review all instructions before you begin, and during assembly, follow the step sequence carefully for successful results.

Flooring and Anchoring: Your storage building must be anchored to prevent wind damage. A base is necessary to construct a square and level building. Anchoring and base materials are not included with your building. We recommend the combined use of an **Arrow Floor Frame Kit** and an **Arrow Anchoring Kit** as an effective method of securing your building to the ground (Available at your local dealer, Arrow's website arrowsheds.com or call Arrow's Customer Service department 1-800-851-1085) or you may construct a base and anchoring system of your choice. Your assembly instructions provide information on a few methods commonly used to secure and level a storage building.

Parts and Parts List: Check to be sure that you have all the necessary parts for your building.

- All part numbers can be found on the parts. All of these numbers (before the -) must agree with the numbers on the Parts List page.

- If you find that a part is missing, include the model number of your building and contact:

Arrow Shed, LLC Customer Service Department
1101 North 4th Street Breese, Illinois 62230

1-800-851-1085 or assist@arrowsheds.com

- Separate contents of the carton by the part number while reviewing parts list. The first few steps show how to join related parts to make larger sub assemblies which will be used later.

- Familiarize yourself with the hardware and fasteners for easier use during construction. These are packaged within the carton. Note that extra fasteners have been supplied for your convenience.

PLAN AHEAD....

A04

Watch the Weather: Be sure the day you select to install your building is dry and calm. Do not attempt to assemble your building on a windy day. Be careful on wet or muddy ground.

Teamwork: Whenever possible, two or more people should work together to assemble your building. One person can position parts or panels while the other is able to handle the fasteners and the tools.

Tools and Materials: These are some basic tools and materials you will need for the construction of your building. Decide which method of anchoring and the type of base you wish to use in order to form a complete list of the materials you will need.

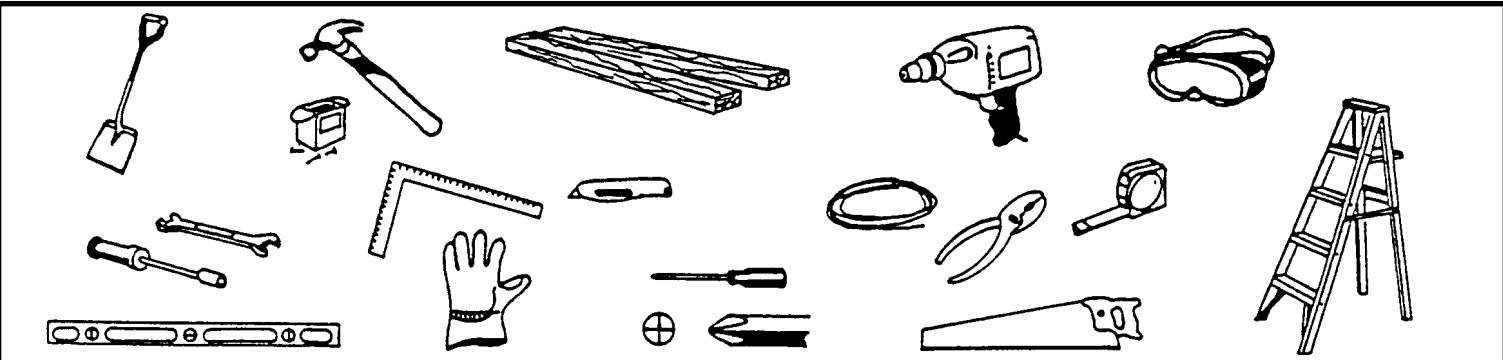

Required	Required	Optional Time-Savers	Base Preparation
<ul style="list-style-type: none">• Eye Goggles• No. 2 Phillips Screwdriver (With Hardened Magnetic Tip) <p>Note: A power screwdriver or variable speed drill with Phillips-tip attachment can speed assembly by as much as 40%.</p>	<ul style="list-style-type: none">• Work Gloves• Step Ladder• Utility Knife / Scissors• Pliers• Carpenter's Level• Tape Measure	<ul style="list-style-type: none">• Wrench / Nut Driver• Electric / Cordless Drill• Square• String (for squaring frame)	<ul style="list-style-type: none">• Hammer and Nails• Spade or Shovel• Hand Saw / Power Saw• Lumber and/or Concrete

Selecting and Preparing Your Site: Before assembly, you will want to decide on a location for your building. The best location is a level area with good drainage.

- Allow enough working space for ease of moving parts into position during assembly. Be sure there will be enough space at entrance for doors to open fully and enough space around the building to be able to fasten the panel screws from the outside.

- Before you begin the first steps in assembling your parts, a base should be constructed and an anchoring system should be ready to use.

SAFETY FIRST...

Safety precautions are important to follow throughout the construction of your building.

•Care must be taken when handling various pieces of your building since some contain sharp edges. Please wear work gloves, eye protection and long sleeves when assembling or performing any maintenance on your building.

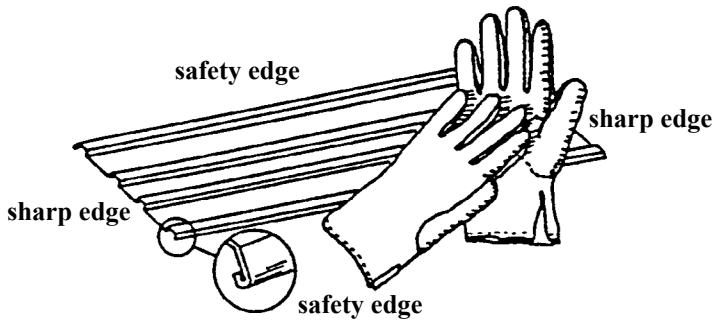

•Keep children and pets away from worksite to avoid distractions and any accidents which may occur.



•Never concentrate your total weight on the roof of the building. When using a step ladder make sure that it is fully open and on even ground before climbing on it.

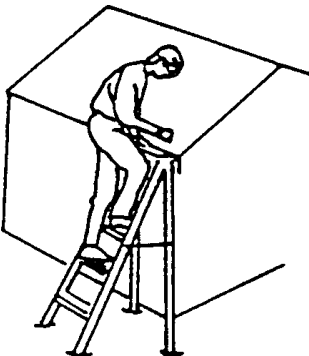

•Practice caution with the tools being used in the assembly of this building. Be familiar with the operation of all power tools.



•Do not attempt to assemble the building if parts are missing because any building left partially assembled may be seriously damaged by light winds. Call 1-800-851-1085 or assist@arrowsheds.com

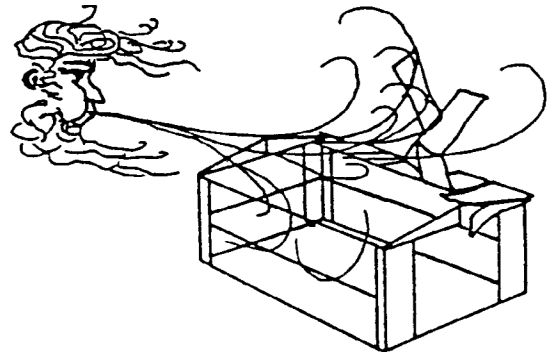

•Do not attempt to assemble the building on a windy day, because the large panels acting as a "sail", can be whipped about by the wind making construction difficult and unsafe.



CARE & MAINTENANCE....

A06

Finish: For long lasting finish, periodically clean and wax the exterior surface. Touch-up scratches as soon as you notice them on your unit. Immediately clean the area with a wire brush; wash it and apply touch-up paint per manufacturer's recommendation.

Roof: Keep roof clear of leaves and snow with long handled, soft-bristled broom. Heavy amounts of snow on roof can damage building making it unsafe to enter. In snow country, Roof Strengthening Kits are available for most Arrow Buildings for added protection against heavy snow accumulation. Contact **Arrow** as outlined on the Ordering Accessories page to place an order.

Doors: Always keep the door tracks clear of dirt and other debris that prevent them from sliding easily. Lubricate door track annually with furniture polish or silicone spray. Keep doors closed and locked to prevent wind damage.

Fasteners: Use all washers supplied to protect against weather infiltration and to protect the metal from being scratched by screws. Regularly check your building for loose screws, bolts, nuts, etc. and retighten them as necessary.

Moisture: A plastic sheet (vapor barrier) placed under the entire floor area with good ventilation will reduce condensation.

Other Tips....

- Wash off inked part numbers on coated panels with soap and water.
- Silicone caulking may be used for watertight seals throughout the building.

Do not store swimming pool chemicals in your building. Combustibles and corrosives must be stored in air tight approved containers.

Keep this Owner's Manual and Assembly Instructions for future reference.

ACCESSORIES...

A07

ROOF STRENGTHENING (heavy snow load) KITS

Extra roof beams and gable braces designed for added protection against heavy snow accumulation. Increases the strength of your roof.

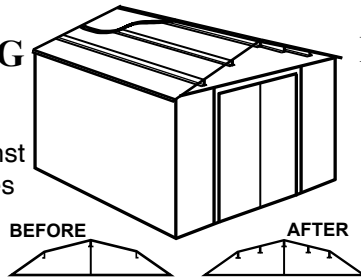

ANCHOR KITS

Model No. AK4

Anchor Kit contains heavy-duty steel augers, 60' (18 m) of steel cable and 4 cable clamps. No digging or concrete pouring, just insert cable under roof, over roof beams, into augers and twist augers into the ground. For buildings larger than 10'x9' (3,0 m x 2,6 m), use 2 kits.

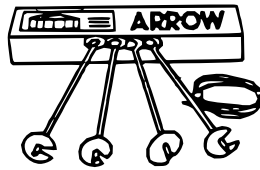

Model No. AK100

New concrete anchor system permits anchoring any size Arrow building directly to a concrete slab. Each kit contains heavy-duty, hot-dipped galvanized steel corner gussets and perimeter clips which fit over the floor frame and lag bolt into a concrete slab. Full assembly instructions and a 1/4" masonry drill bit are included.

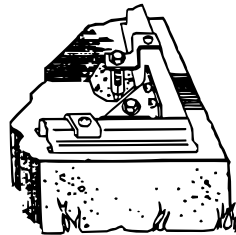

Model No. AK600

Earth Anchor Kit anchors any size Arrow building to the ground. Each kit contains heavy duty, hot-dipped galvanized steel corner gussets and 4 earth anchors.

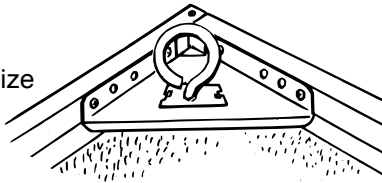

TOOL HANGING RACK

Model No. TH100

The perfect tool organizer. Twin 25 1/2" (64,8 cm) steel channels plus five heavy-duty snap-in hangers and a small tool holder for screwdrivers, pliers, etc. Holders slide along channel for fully adjustable spacing. Great for garage, basement, or the back of any door. Fits all Arrow storage buildings.

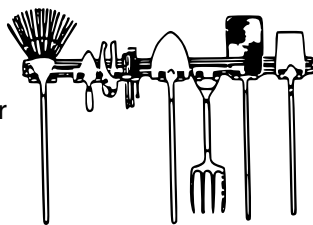

FLOOR FRAME KITS

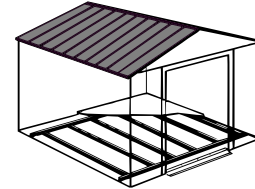

MODELS FB47410, FB5465, FB106-A
FB109-A and FB1014-A

A simple new floor frame system made of heavy-duty, hot-dipped galvanized steel. Use as base for plywood, sand or stone.

ATTIC KIT / WORKBENCH KIT

Model No. AT101

Heavy-duty galvanized steel bars that fit all 10' (3,0 m) wide Arrow buildings. They install quickly and easily to help organize space and create more useable space as an attic or workbench. Will hold up to 250 lbs. (113 kg) evenly distributed.

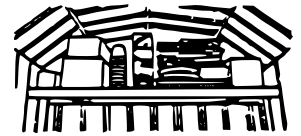

Some drilling required to fit buildings without mid-wall bracing.

SHELF UNITS

Heavy-duty, galvanized steel shelf units help organize storage space. They easily mount on the wall or sit on the floor. Fits all Arrow buildings.*

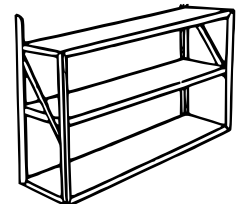
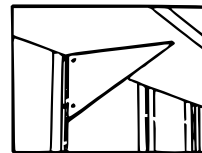
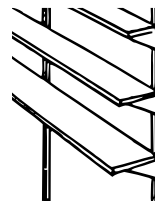

Model No. SS404

- Makes 8" to 12" (20,3-30,5 cm) wide shelves in any length.
- Brackets, braces, hardware included. Lumber is not included.

Model No. SS900-B

- Grey color
- 3 shelves
- Holds up to 85 lbs. (38 kg) (even weight distribution)

* Some drilling required to fit buildings without mid-wall bracing.

ORDERING ACCESSORIES....

A08

02/13

We recommend that you purchase accessory items from your local storage building dealer whenever possible; however, because the full line of accessories is not always available from all dealers, **Arrow** is offering them to you on a direct basis.

There are two ways to order Arrow Storage Building Accessories:

Option 1	Option 2
<p data-bbox="191 716 630 789">Accessories can be purchased through</p> <p data-bbox="282 831 539 863">arrowsheds.com</p>	<p data-bbox="857 722 1451 795">Order accessories by telephone using your MasterCard or Visa credit card.</p> <p data-bbox="951 835 1357 909">Call toll free 1-800-851-1085 (Customer Service).</p> <p data-bbox="967 949 1341 980">Allow 2 weeks for delivery.</p>

SPECIAL NOTE:

If your accessory is shipped via truck line a day time phone number is required to arrange delivery. If no one is available to sign for the delivery, you may be subject to a re-delivery charge assessed by the carrier.

Base

F09

The Base For Your Building

No matter which of the options below you choose for a base, an ARROW ANCHORING KIT is recommended as an effective method of properly securing your building after assembly is complete.

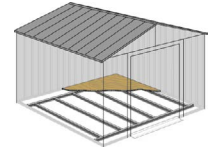

OPTION 1: Directly on ground (earth)

Assemble your building directly on level ground (grass, dirt, rock, sand, etc.). If you choose this option Arrow has a simple kit available to provide a floor **inside** the shed to keep stored items off the ground. This kit can be used to support a plywood floor (wood not included) or be filled with sand/rock to provide a solid surface. (Order No. FB1014-A or 68387-A)

Allow 1 - 2 hours for construction.

OPTION 2: Wood Platform

If you decide to build your own base, be sure to select the appropriate materials.

These are the recommended materials for your base:

- 2 x 4's (38 mm x 89 mm) Pressure Treated Lumber
 - 5/8" (15,5 mm) 4 x 8 (1220 mm x 2440 mm) Plywood-exterior grade
- NOTE:** Pressure Treated Lumber must not be used where it will make contact with your storage building. The properties of Pressure Treated Lumber will cause accelerated corrosion.

If Pressure Treated Lumber comes in contact with your storage building your warranty will be voided.

- 10 & 4 penny Galvanized Nails
- Concrete Blocks (optional)

The platform should be level and flat (free of bumps, ridges etc.) to provide good support for the building. The necessary materials may be obtained from your local lumber yard.

To construct the base follow instructions and diagram.

Construct frame (using 10 penny galvanized nails)

Measure 16"/24" (40,6 cm/61,0 cm) sections to construct inside frame (see diagram)

Secure plywood to frame (using 4 penny galvanized nails)

Allow 6 - 7 hours for construction.

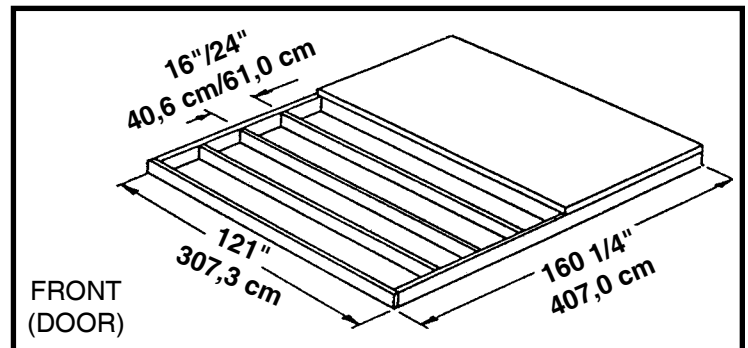

Note: Platform/Slab will extend 9/16" (1,4 cm) beyond floor frame on all four sides. Seal this 9/16" (1,4 cm) of wood with a roofing cement (not included), or bevel this 9/16" (1,4 cm) of concrete when pouring, for good water drainage.

OPTION 3: Concrete Slab

The slab should be at least 4" (10,2 cm) thick. It must be level and flat to provide good support for the frame.

The following are the recommended materials for your base.

- 1 x 4's (19 mm x 89 mm) (will be removed once the concrete cures)
- Concrete
- Sheet of 6 mil plastic
- We recommend for a proper strength concrete to use a mix of:
1 part cement ● 3 parts pea sized gravel ● 2 1/2 parts clean sand

Prepare the Site/Construct a Base

1. Dig a square, 6" (15,2 cm) deep into the ground (remove grass).
2. Fill up to 4" (10,2 cm) in the square with gravel and tamp firm.
3. Cover gravel with a sheet of 6 mil plastic.
4. Construct a wood frame using four planks of 1x4 (19 mm x 89 mm) lumber.
5. Pour in concrete to fill in the hole and the frame giving a total of 4" (10,2 cm) thick concrete. Be sure surface is level.

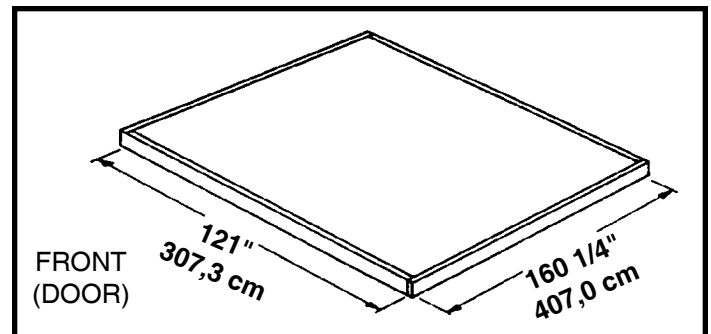

Allow 3 - 5 hours for construction and a week for concrete curing time. Note: Finished Slab dimensions, with lumber removed.

Anchoring

A10

Anchoring Down The Building

It is important that the entire floor frame be anchored after the building is erected.

Below are recommended ways of anchoring.

Arrow Anchoring Kit: (Model No. AK4 or 60298)

Recommended for use with **any** suggested base.

Contains: 4 Anchors with Cable, Clamps and installation instruction.

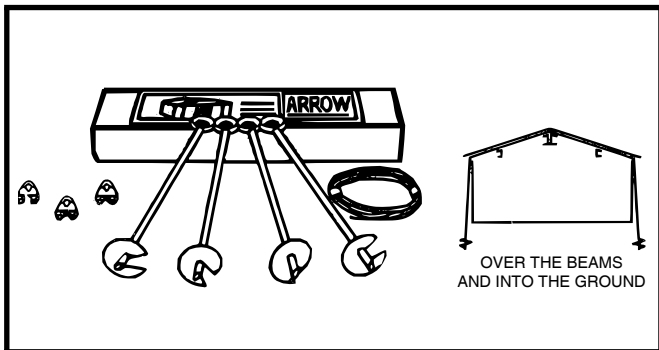

Anchoring into Wood/Post:

Use 1/4" (6 mm) Wood Screws. There are 1/4" (6 mm) dia. holes provided in the frames for proper anchoring.

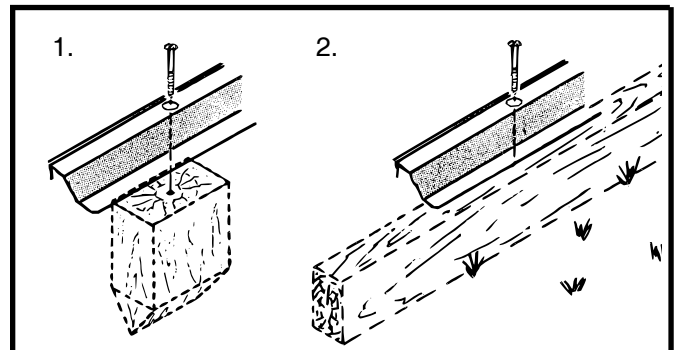

Arrow Anchoring Kit: (Model No. AK100 or 68383)

Recommended for use with the **concrete** base.

Contains: Corner gussets, perimeter clips, hardware, 1/4" masonry drill bit and installation instruction.

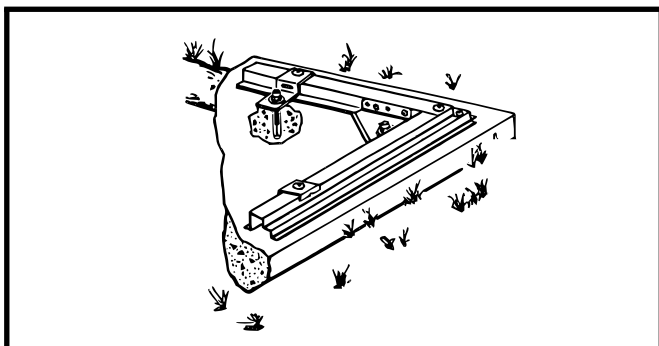

Anchoring into Concrete:

1. For poured concrete slab or footing or patio blocks: Use 1/4" x 2" (6 mm x 51 mm) Lag Screws.
2. For Anchor Post of Concrete poured after building is erected: Use 1/4" x 6" (6 mm x 152 mm) Lag Screws.

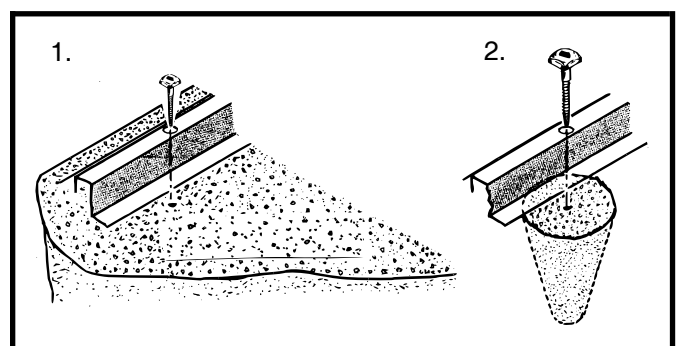

Hardware

ST11

Remove from bag of screws
and save for the last step



65103
#8-32 Hex Nut (253)



65900A
#10Bx1/2" (13 mm)
Black Screw (8)
(Packed with Screws)



65923
#8-32x3/8" (10 mm)
Bolt (239)



65004
#8Ax5/16" (8 mm)
Screw (460)

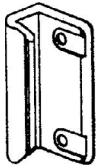

66045
Handle (2)

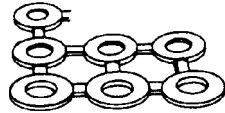

66646
Washer (400)
(10 sheets of 40)



65109
#8-32 Acorn Nut (14)
(Packed with Screws)

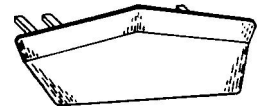

67468
Peak Cap (6)
(Arrow Logo)

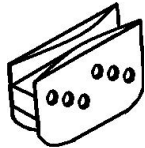

66769
Door Slide (4)

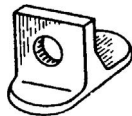

66382
Lower Door Guide (4)

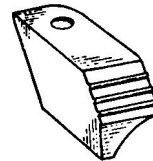

66183
Roof Trim Cap
(2 right & 2 left)

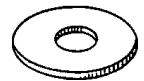

65020
1/4" Door Washer (14)
(Packed with Screws)

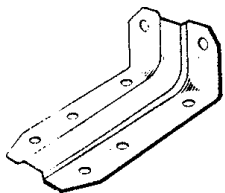

6228
Track Support (2)

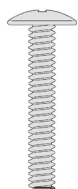

65958
#8-32x7/8" (22 mm)
Bolt (14)
(Packed with Screws)

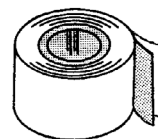

67545
Weather Stripping (1)

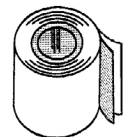

67293
Weather Stripping (1)

Parts List

ST12

Assembly Key No.	Part Number	Part Description	Quantity in Carton	Check List
1	5291	Front Siding (3 board)	2	
2	5305	Side Siding (3 board)	4	
3	5307	Rear Siding (3 board)	2	
4	6114	Small Right Gable	2	
5	6115	Small Left Gable	2	
6	10501	Horizontal Door Brace	4	
7	7858	Large Right Gable	2	
8	7859	Large Left Gable	2	
9	7861	Roof Panel	8	
10	7862	Right Roof Panel	2	
11	7863	Left Roof Panel	2	
12	8109	Vertical Door Brace	2	
13	8715	Left Corner Post	2	
14	8716	Right Corner Post	2	
15	8717	Door Jamb	2	
16	8718	Splice Post	1	
17	8734	Side Splice Post	2	
18	8736	Rear Siding (5 board)	4	
19	8737	Front Siding (5 board)	4	
20	10509	Right & Left Doors	2	
21	9193	Side Siding (5 board)	8	
22	67521	Edge Trim	2	
23	67730	Foam Board	2	
24	6015	Side Roof Trim	2	
25	6403	Door Track Splice	1	
26	6797	Ridge Cap	6	
27	6869	Ridge Cap	3	
28	6892	Right Side Roof Trim	2	
29	6893	Left Side Roof Trim	2	
30	9366	Door Track	2	
31	5986	Rear Wall Angle	2	
32	6085	Roof Beam Bracket	4	
33	6227	Roof Beam Brace	2	
34	10386	Roof Beam	12	
35	6636	Gable Brace	2	
36	7860	Mid Gable Brace	4	
37	10391	Side Wall Angle	4	
38	9006	Right Rear Wall Channel	1	
39	10398	Right Side Wall Channel	2	
40	8936	Rear Floor Frame	2	
41	10387	Side Floor Frame	4	
42	9003	Stud	10	
43	9365	Front Wall Channel	2	
44	9367	Front Floor Frame	2	
45	8934	Ramp	1	
46	9007	Left Rear Wall Channel	1	
47	10399	Left Side Wall Channel	2	

Assembly by Key No.

ST13

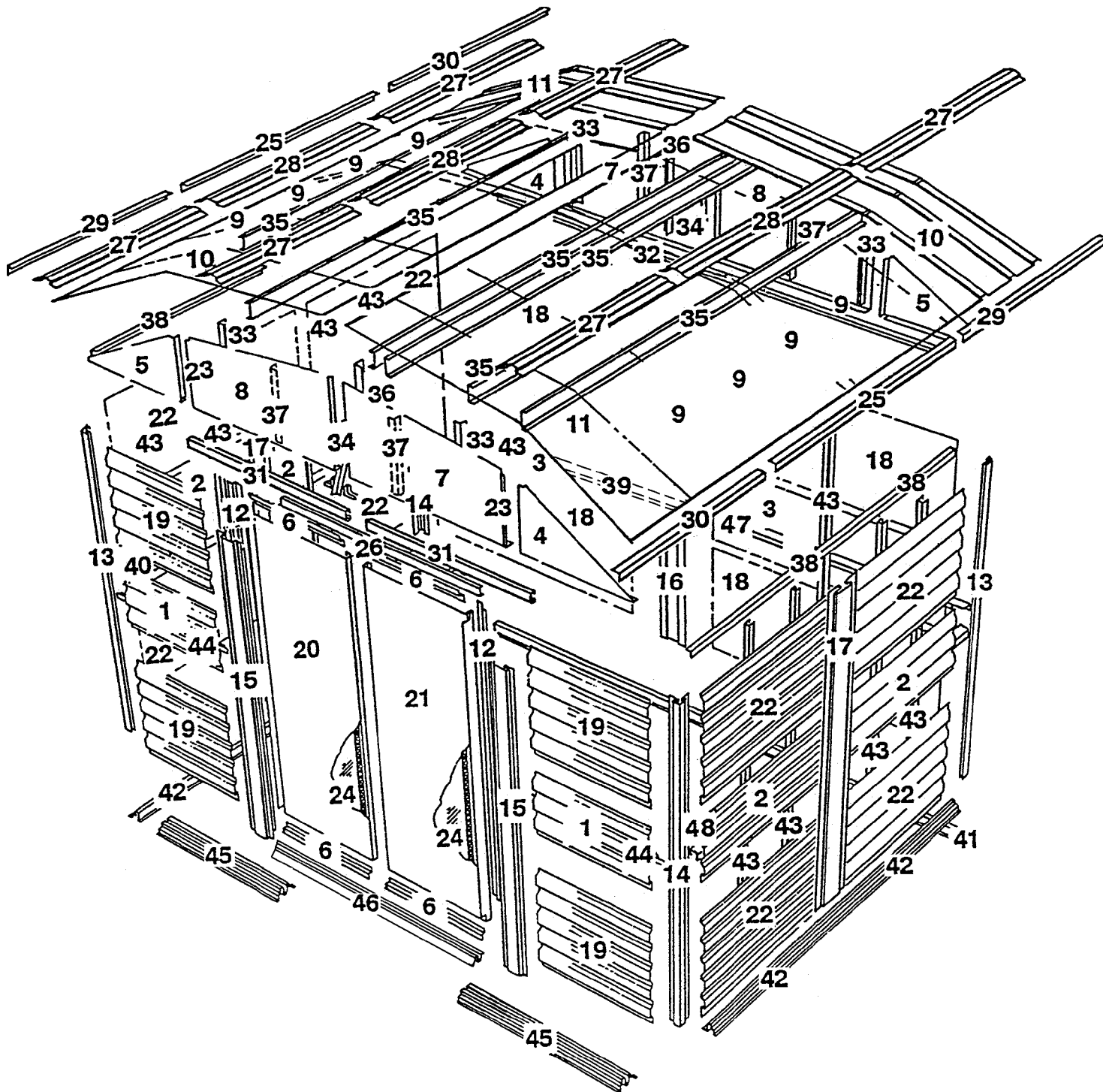

Step 1

SO14

● Parts Needed For ● Floor Frame Assemblies

- 8934 Ramp (1)
- 9367 Front Floor Frame (2)
- 8936 Rear Floor Frame (2)
- 10387 Side Floor Frame (4)

The front floor frame is made up of three pieces. The side floor frames and the rear floor frame are made up of two pieces. The holes in these pieces will align when the pieces are positioned with correct amount of overlap. The illustrations below show the proper overall length for the sides, rear and front. Proceed as follows:

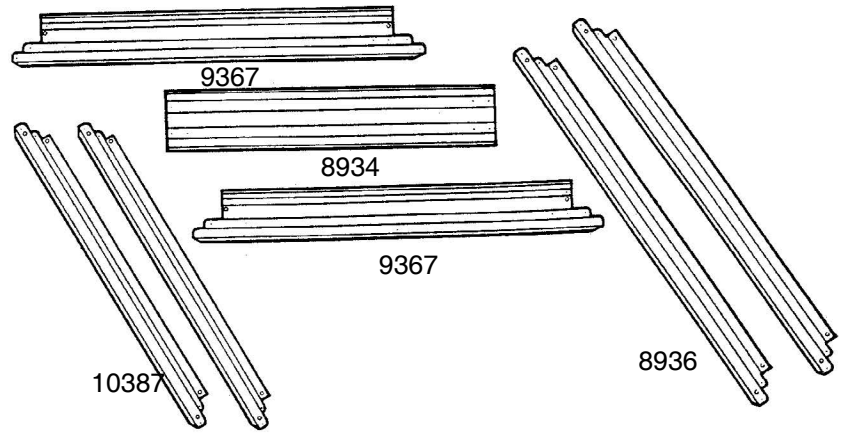

1 Place the **front floor frames** as shown. Center the **ramp**, with drain holes facing outside, on top of the two front floor frames. Join the frames by inserting eight screws.

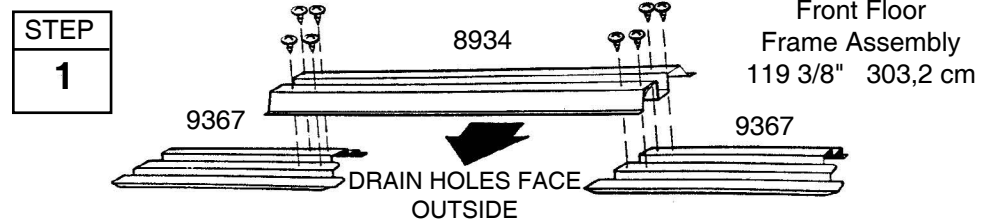

2 Overlap the **side floor frames** and the **rear floor frames** as shown. The holes in these pieces will align when the pieces are positioned with correct amount of overlap. See the illustrations below for the proper overall length of the side and rear floor frames. Join the frames by inserting four/five bolts into each frame set as shown.

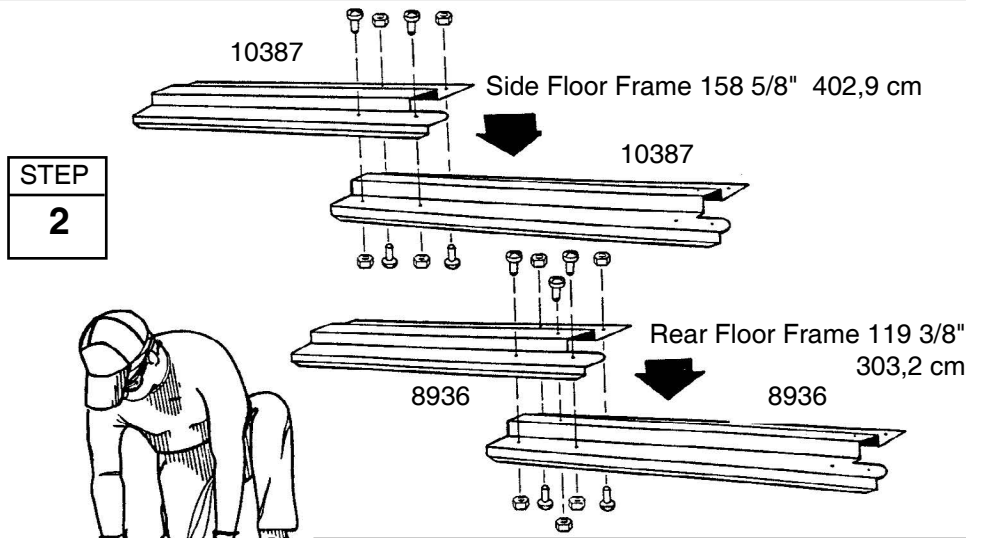

3 Double check the length of each and set these pieces aside for later use.

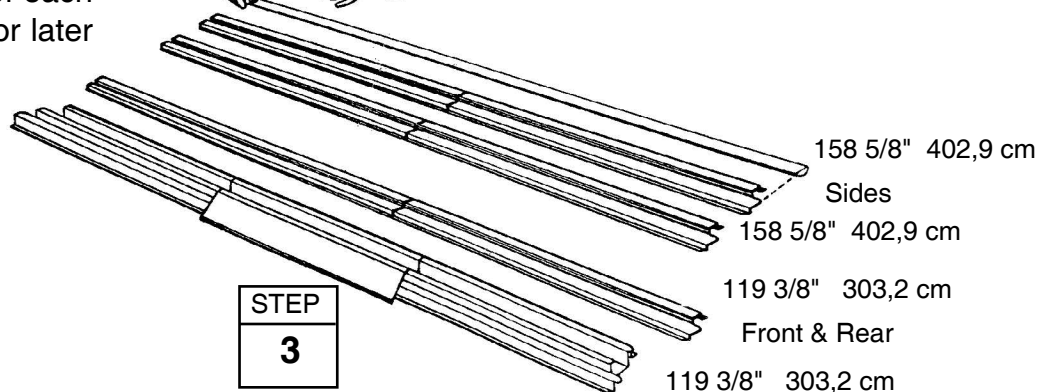

Step 2

ST15

● Parts Needed For ● Frame Assemblies

- 5986 Rear Wall Angle (2)
- 10391 Side Wall Angle (4)
- 10398 Right Side Wall Channel (2)
- 10399 Left Side Wall Channel (2)
- 9006 Right Rear Wall Channel (1)
- 9007 Left Rear Wall Channel (1)

The main frame pieces reinforce the walls. These pieces will later be installed in the center and at the top edge of the side walls and the rear wall. Proceed as follows:

1 Overlap the **right & left rear wall channel** pieces as shown in the figure and fasten the two pieces together with 4 bolts as shown.

2 Make two **side wall channels** by overlapping the right & left side wall channel pieces as shown. Fasten each set together with 8 bolts.

3 Overlap the **rear wall angle** pieces as shown in the figure and fasten them together with *one bolt in the center hole* (five holes will align).

4 Make two **side wall angles** by overlapping the side wall angle pieces as shown. Fasten each set together with *one bolt thru the second large hole from the end of each part*.

5 Double check the length of each and set these pieces aside for later use.

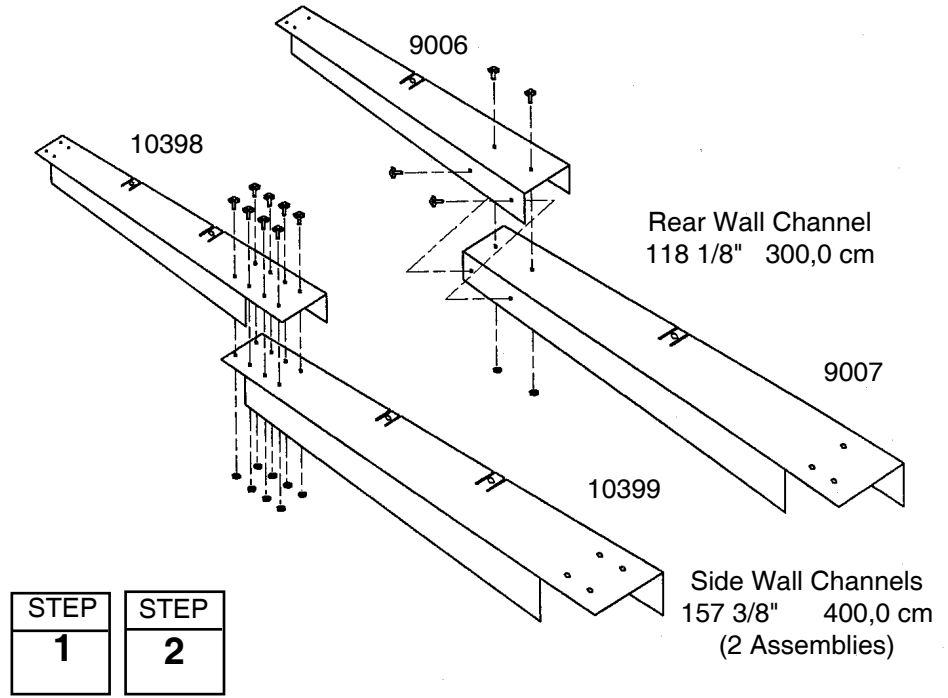

STEP	STEP
1	2

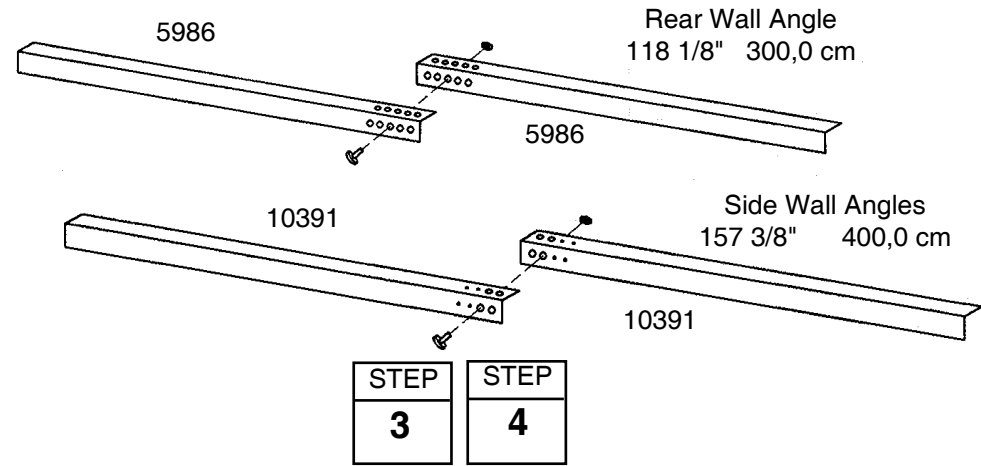

STEP	STEP
3	4

Rear Wall Angle 118 1/8" 300,0 cm
Side Wall Angles 157 3/8" 400,0 cm (2 Assemblies)

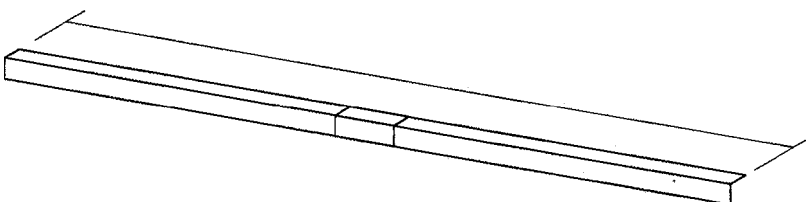

STEP
5

Step 3

SS16

● Parts Needed For ● Roof Beam Assemblies

● 10386 Roof Beam (12)

The roof beams join the two gables and support the roof panels. The main roof beam is made up of four pieces overlapped back to back at the center. The left and right roof beam assemblies are made up of two pieces.

Hint: These pieces are force-fitted, so you may have to press hard to join them together.

1 Place one end of a roof beam inside another roof beam so that the six holes in each piece align. Make six sets of roof beams by repeating this procedure. **Do not insert bolts yet.**

2 Take two of the pressed-together roof beams and join them as shown to form the main roof beam assembly. Hold the assembly together and fasten with 14 bolts. Build **only one** Doubled Beam Assembly.

3 Fasten the other four pressed-together roof beams with eight bolts to make the left and right roof beam assemblies.

4 Double check the length of each and set these pieces aside for later use.

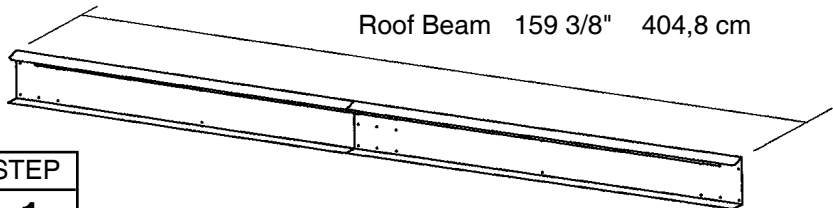
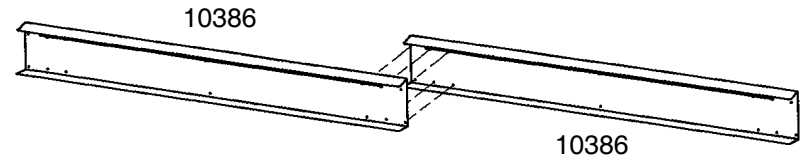

STEP
1

STEP
2

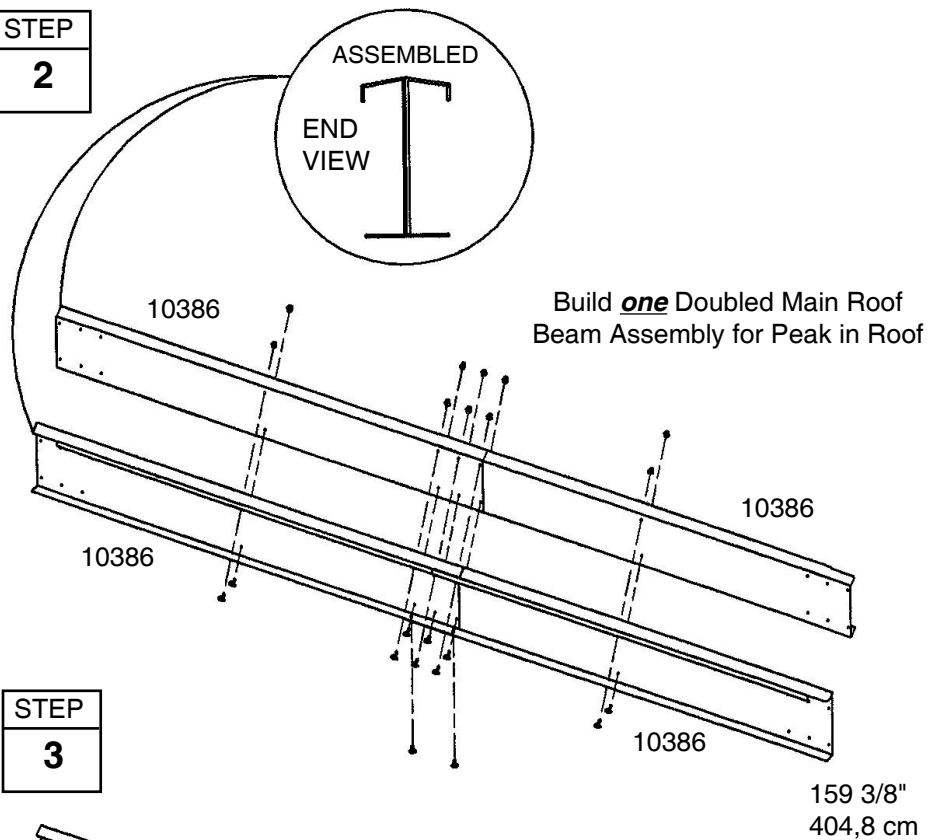

STEP
3

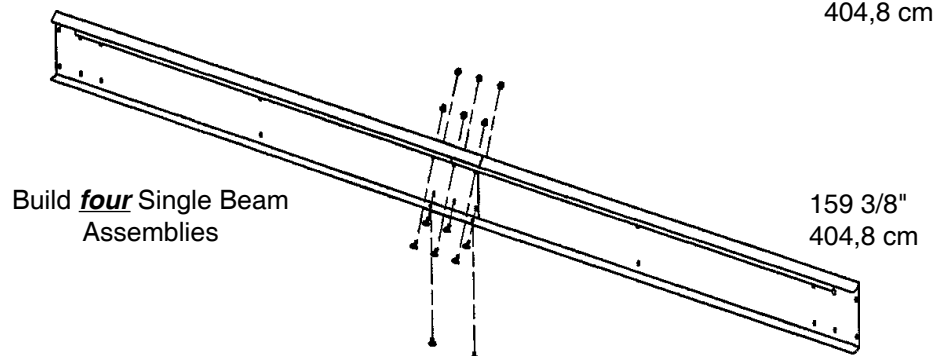

Step 4

A17

● Parts Needed For ● Door Track Assembly

- 6403 Door Track Splice (1)
- 9366 Door Track (2)

The door track assembly supports the sliding doors and reinforces the front wall. It is made up of three pieces.

1 Using the **door track splice**, (painted), join the **door track** (galvanized) pieces end-to-end as shown.

2 Insert four screws *from the underside only*.

Hint: The holes in the top side of the door track assembly are for fastening the gable to the top of the front wall in a later step.

3 Position **door slides** onto the legs, from the end of door track assembly, as shown in the end view.

4 Set this piece aside for later use.

NOTE:
Door Track Splice (painted part)

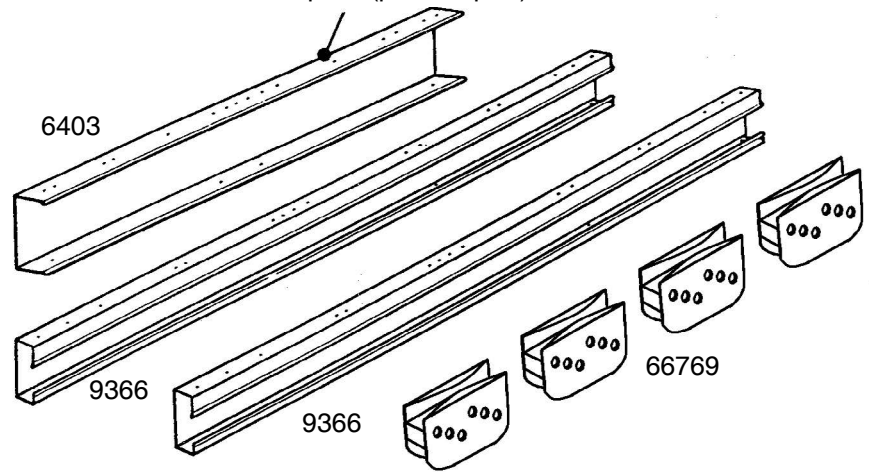

STEP
1

STEP
2

Long Leg
on Top
Short Leg
on Bottom

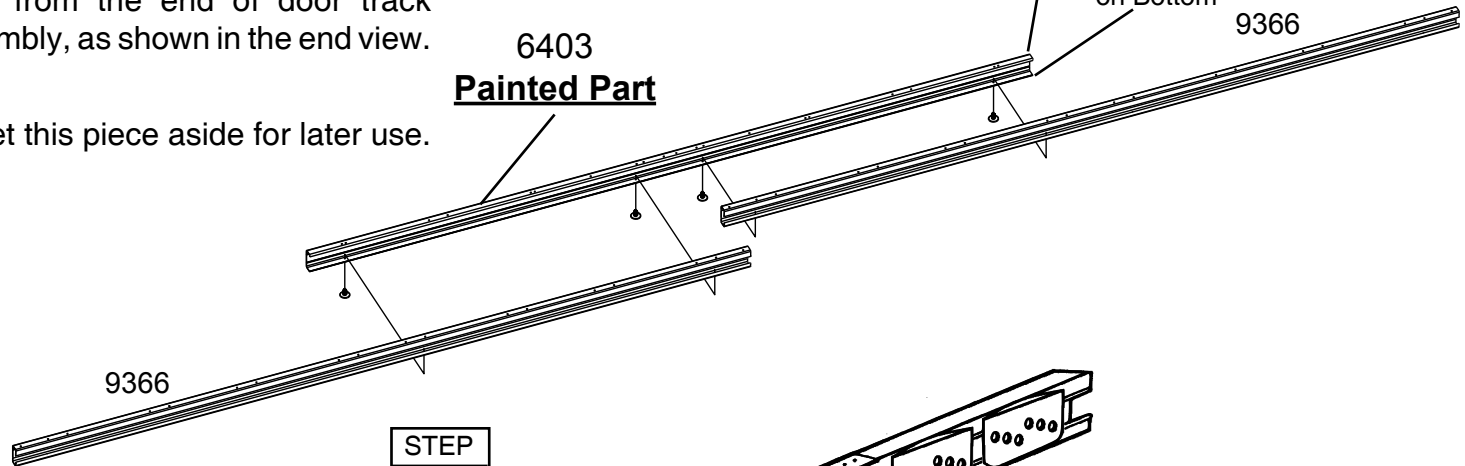

STEP
4

118 1/8"
300,0 cm

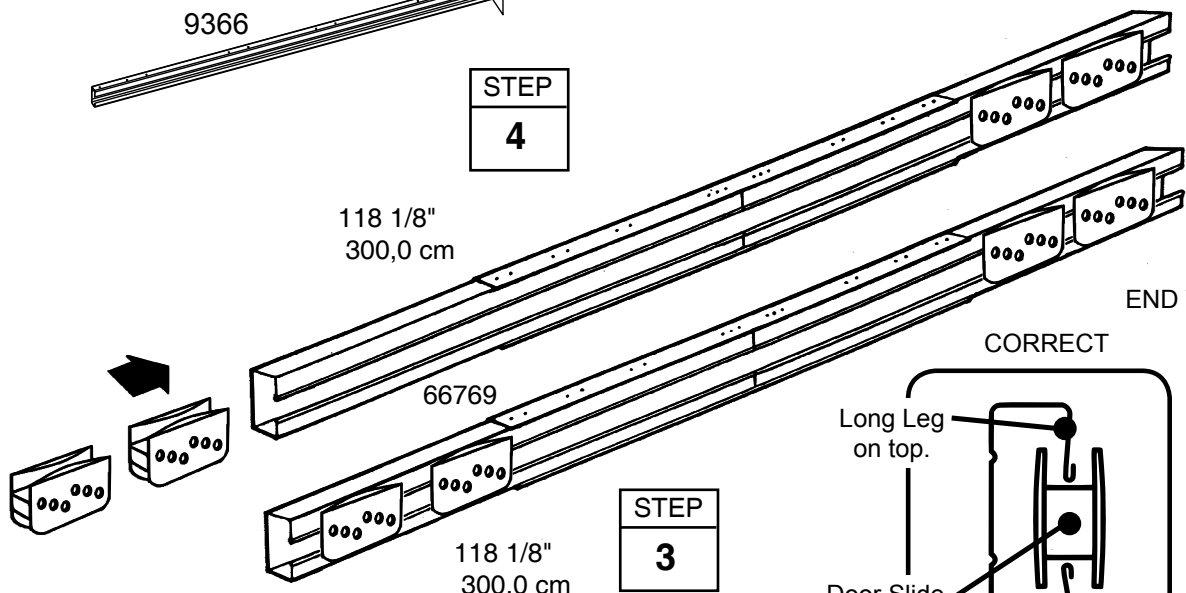

END VIEW

CORRECT

INCORRECT

Long Leg
on top.

Door Slide

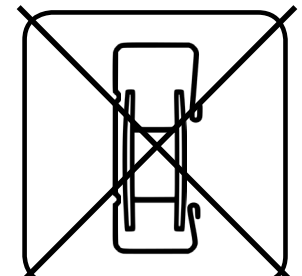
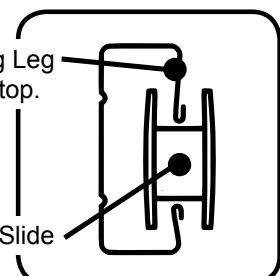

Step 5

SO18

● Parts Needed For ● Floor Frame

- Front Floor Assembly (1)
- Side Floor Assembly (2)
- Rear Floor Assembly (1)

1 Assemble the four corners of the floor frame using two screws at each corner as shown. At the front corners fasten bolts through from the bottom with nuts on top.

STEP
1

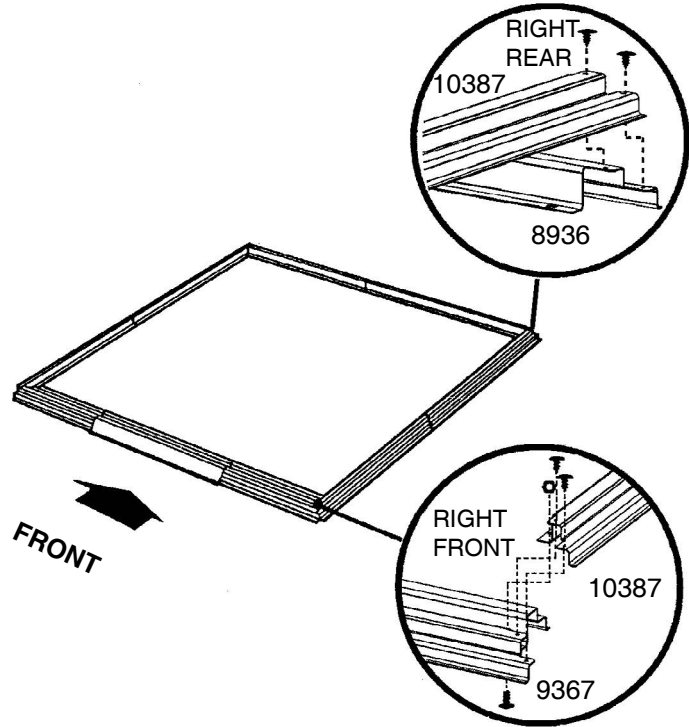

2 Measure the floor frame diagonally. When the diagonal measurements are equal, the floor frame is square.

When Diagonal Measurements are Equal the Floor Frame is Square.

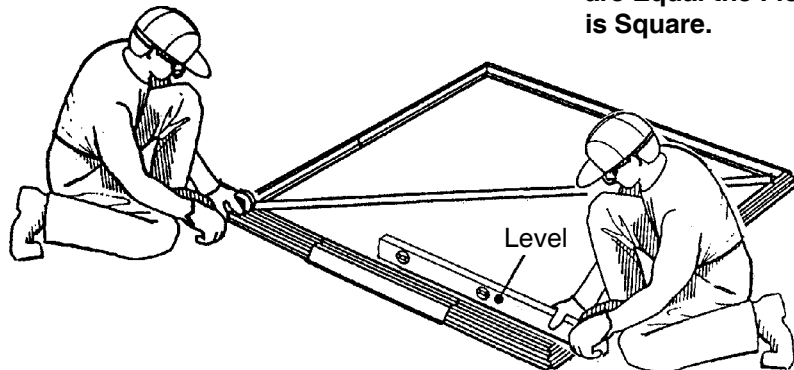

STEP
2

NOTE

If using a wood platform or concrete slab do not fasten the floor frames to your base at this time. You will anchor the building after it is erected.

The floor frame *must be square and level* or holes will not align.

Step 6

ST19

● Parts Needed For ● Posts/Top Frames

- 8716 Right Corner Post (2)
- 8715 Left Corner Post (2)
- Door Track Assembly (1)
- Rear Wall Angle Assembly (1)
- Side Wall Angle Assemblies (2)

NOTE

The remainder of the building assembly requires many hours and more than one person. Do not continue beyond this point if you do not have enough time to complete the assembly today. A partially assembled building can be severely damaged by light winds.

The top frame pieces give rigidity to the side walls and provide a surface for attaching the gables which support the roof.

1 Position **right & left corner posts** at the corners of the floor frame as shown. The angled end of each post must be placed on top of all four corners. Fasten the corner post to the floor frame with two screws.

Support the corner posts with stakes until top frames are attached.

2 Fasten the **door track assembly** (holes on top) behind the top of the front corner posts using screws. See the figure.

3 Fasten the **rear wall angle** behind the top of the rear posts using screws.

4 Fasten the **side wall angles** behind the top of the side posts using screws. Side wall angles overlap rear wall angle in corners.

The floor frame *must be square and level* or holes will not align.

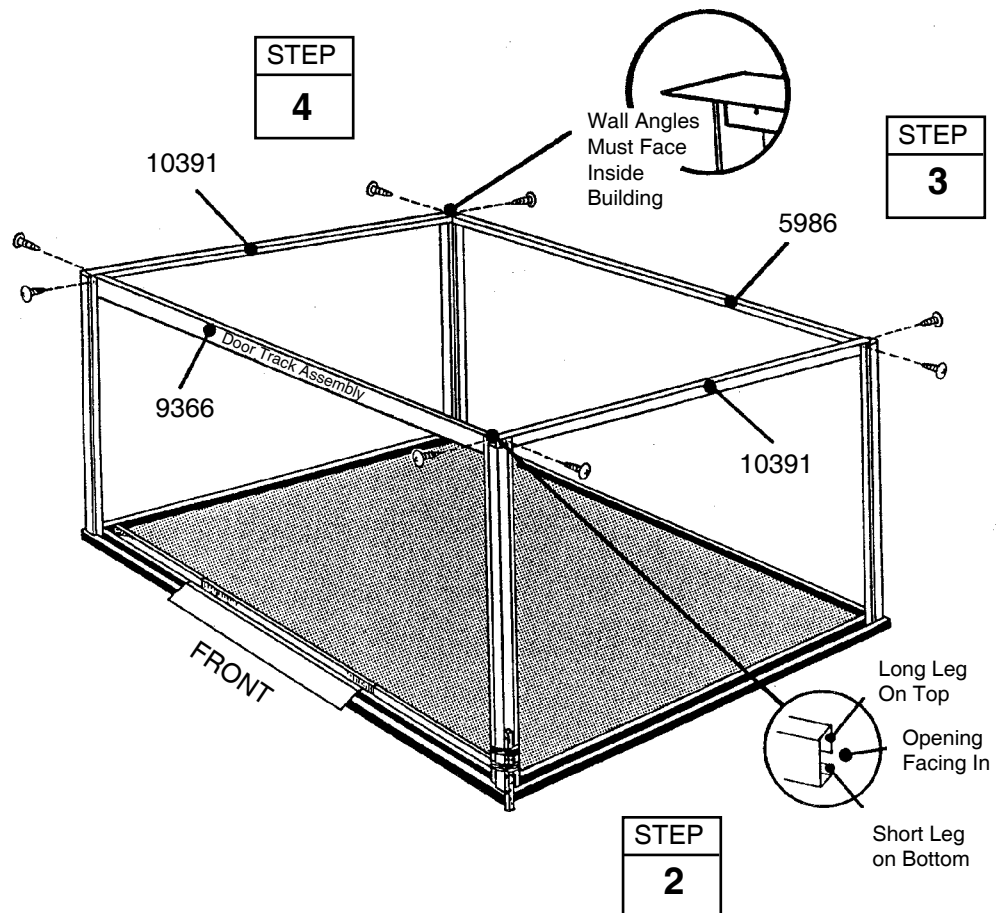
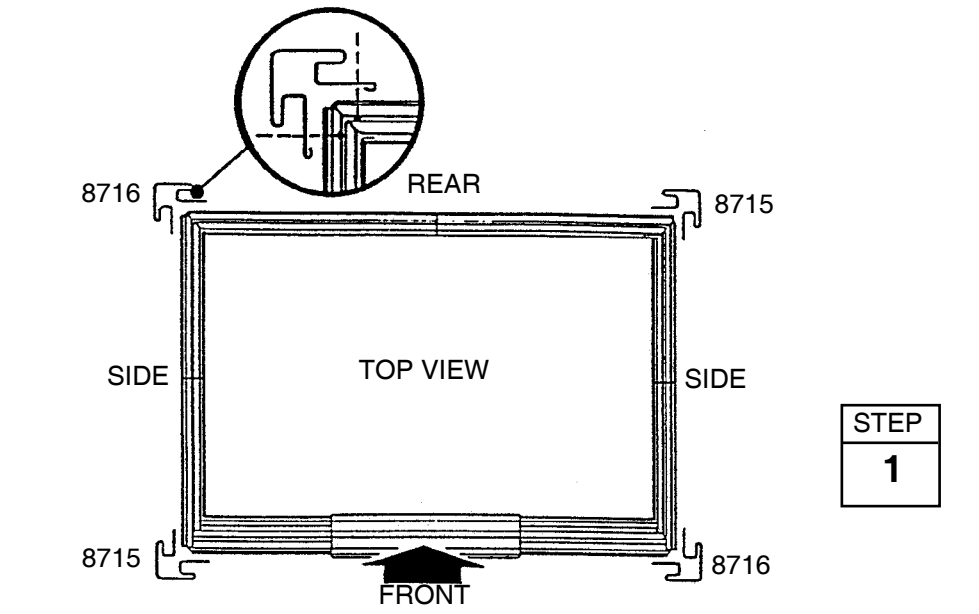

Step 7

ST20

● Parts Needed For ● Splice Post

- 8718 Rear Splice Post (1)
- 8734 Side Splice Post (2)

STEP

1

The splice posts support the walls.

1 Position a **rear splice post** at the center of the rear wall and fasten using 2 nuts and bolts into rear wall angle and 2 screws into rear floor frame.

Hint: Measure or count holes to determine if post is centered on rear.

2 Fasten **side splice posts** to the sides of building using screws into side wall angles and side floor frames. Angled end of post must be on top.

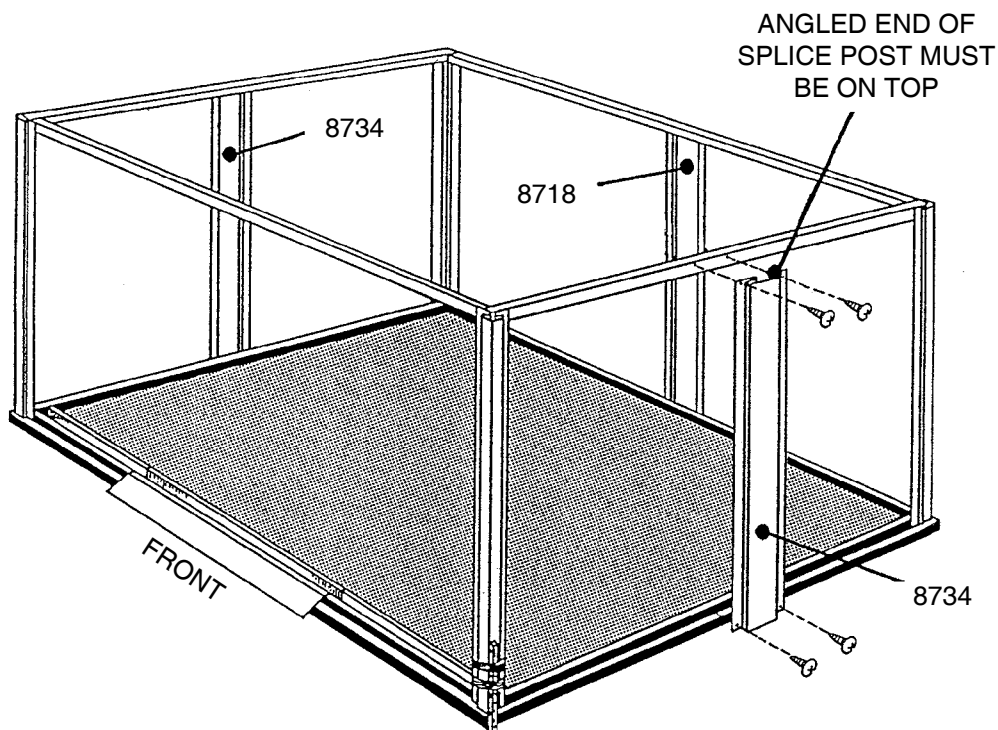
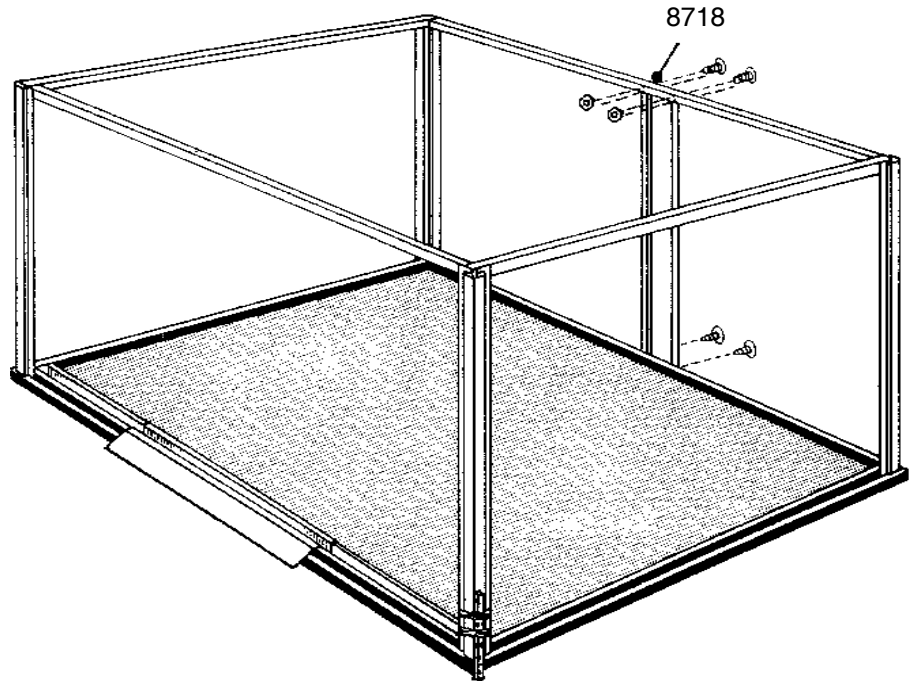

STEP

2

Step 8

ST21

● Parts Needed For ● Door Jamb

● 8717 Door Jamb (2)

The door jambs reinforce the door opening and provide an attractive trim.

1 Fasten the top of the **door jambs** to the door track with two screws. Do the same for the bottom into frame. Notched edge faces toward center of building.

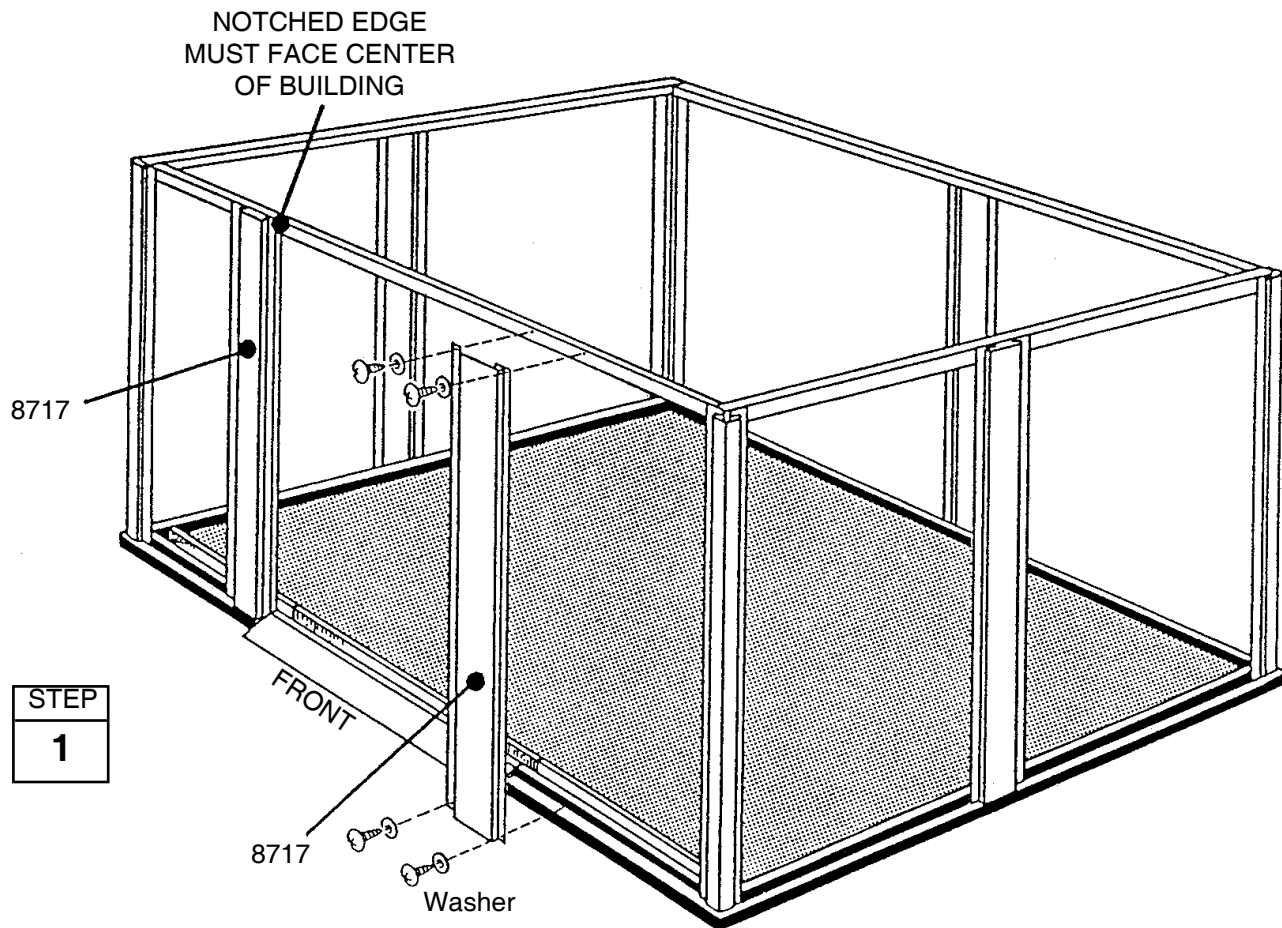

Step 9

ST22

● Parts Needed For ● Mid Frames/Studs

- Side Wall Channel Assemblies (2)
- Rear Wall Channel Assembly (1)
- 9003 Stud (10)
- 9365 Front Wall Channel (2)

1 Wearing gloves, bend the tabs on each mid wall channel down.

2 Fasten **side wall channel assemblies** to the sides of building at the splice and corner posts using screws.

3 Fasten the **rear wall channel assembly** across the rear of building overlapping side channels and fastening corners using bolts and nuts.

4 Following dimensions, place **studs** between corner and splice post. Position stud inside top angle and fasten with a screw.

5 Fasten middle of stud to channel with a screw from inside building.

6 Rest bottom tab of stud outside floor frame, but do not fasten at this time. Repeat procedure for the remaining studs around the building.

7 Fasten **front wall channel** to the door jamb and corner post using screws.

STEP
1

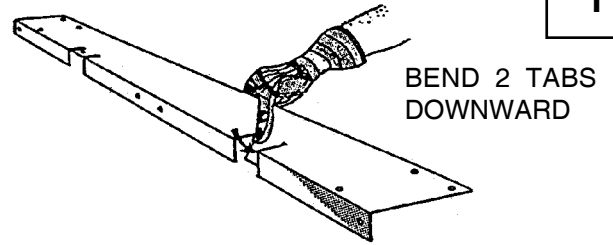

STEP
3

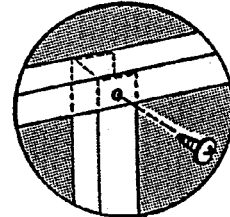

STEP
2

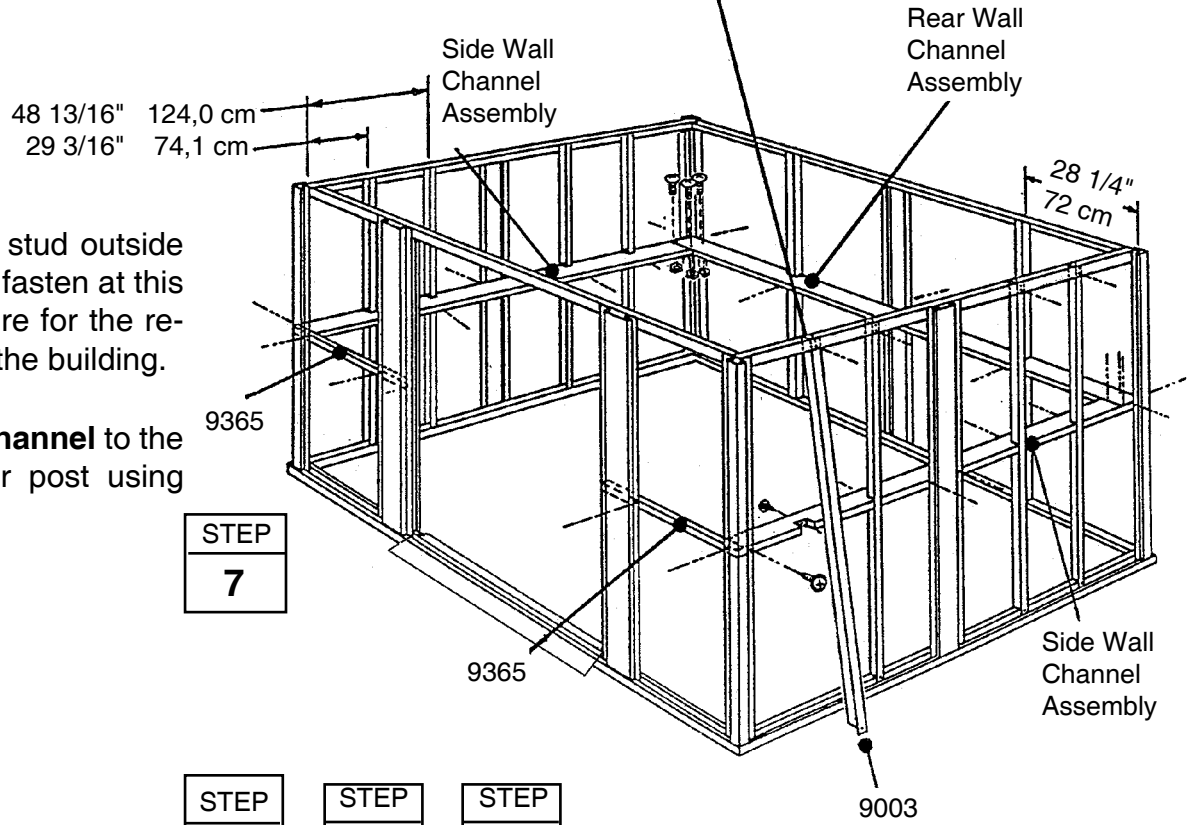

STEP
7

STEP
4

STEP
5

STEP
6

DO NOT FASTEN TAB AT THIS TIME

Step 10

ST23

● Parts Needed For ● Side/Rear/Front Siding

- 9193 Side Siding (5 board) (8)
- 5305 Side Siding (3 board) (4)
- 8736 Rear Siding (5 board) (4)
- 5307 Rear Siding (3 board) (2)
- 8737 Front Siding (5 board) (4)
- 5291 Front Siding (3 board) (2)

Each screw in the wall requires a washer.



CORRECT



INCORRECT

1 Slide **side siding** (5 board) into channels of corner and splice posts, flat edge upward, slotted edge down resting on floor frame. Always follow this pattern. Fasten lower edge and tab of stud to floor frame using screws. Fasten center to stud with screws. Do not fasten top edge yet.

2 Install **side siding** (3 board) as before. Note how the slot in lower edge must overlap flat edge of last siding. Fasten both siding panels to stud at this overlap.

3 Install **side siding** (5 board) to the top as before. Remove and re-use screw in angle to fasten top siding.

4 From inside building, fasten siding to corner posts and splice post using screws.

5 Install **rear siding** and **front siding** as before. Note that the front siding is only fastened from inside.

NOTE

Be careful to install the correct panel in each position as shown.

The floor frame *must be square and level* or holes will not align.

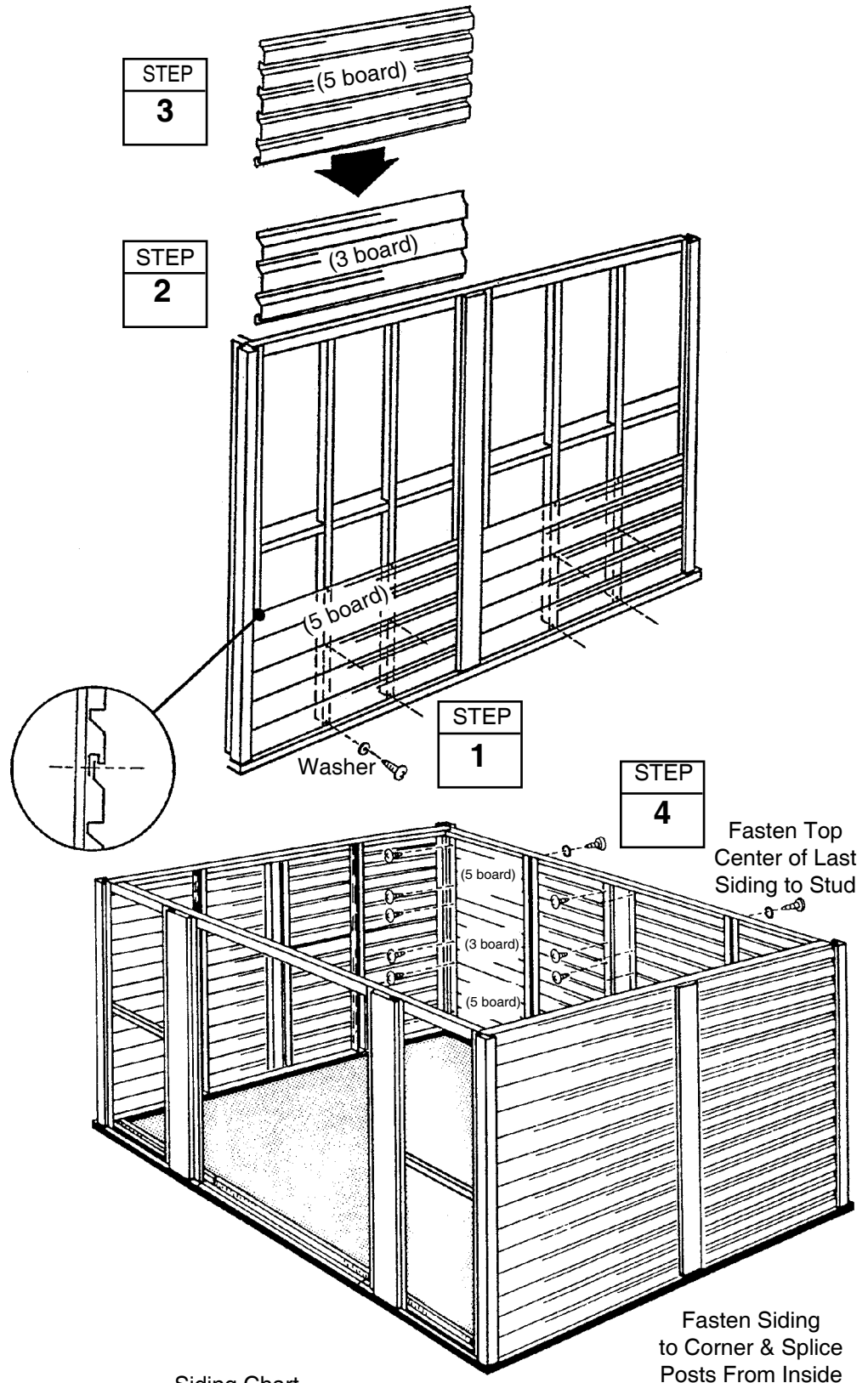

Siding Chart

Front Siding (3 board)	Front Siding (5 board)	Side Siding (3 board)	Side Siding (5 board)	Rear Siding (3 board)	Rear Siding (5 board)
5291	8737	5305	9193	5307	8736

Fasten Siding to Corner & Splice Posts From Inside

Step 11

ST24

● Parts Needed For ● Gable Assemblies

- 7858 Large Right Gable (2)
- 7859 Large Left Gable (2)
- 6114 Small Right Gable (2)
- 6115 Small Left Gable (2)
- 6085 Roof Beam Bracket (4)
- 7860 Mid Gable Brace (4)

The gables go on top of the front and rear walls to support the roof beams.

NOTE

The gables are packed nested together and might be mistaken as one piece. Carefully separate them before continuing.

1 Apply **edge trim** to the edge of the **large left gables** and the **large right gables**, cut to length.

2 Join the large gables to the small gables on the left and right sides using four bolts, washers and nuts on each side. This part of the gable is called the *outer gable leg*.

3 Attach the four **roof beam brackets** to the outer gable legs using two bolts in the two bottom holes of each bracket.

4 Attach the four **mid gable braces** to the gables using three bolts, washers and nuts.

NOTE

Mounting leg of brace must face toward center of gable

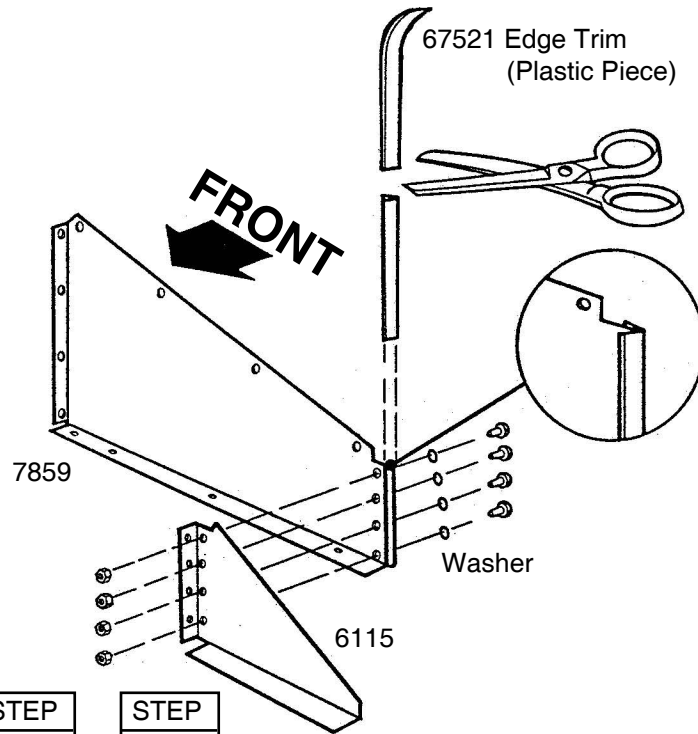

STEP
1

STEP
2

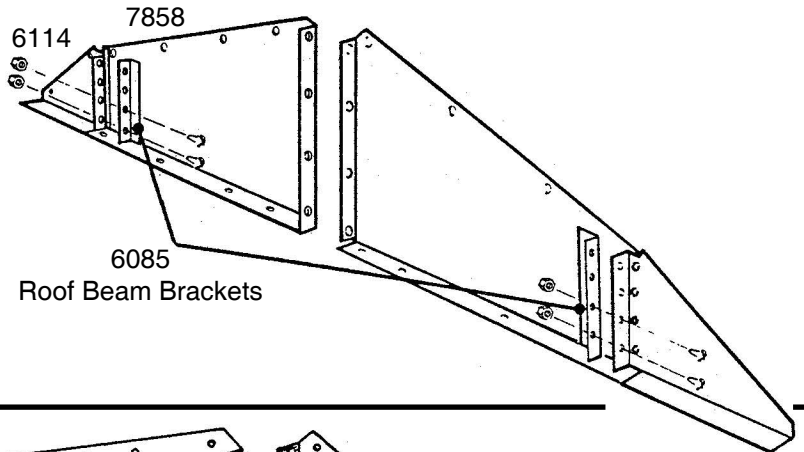

STEP
3

6085
Roof Beam Brackets

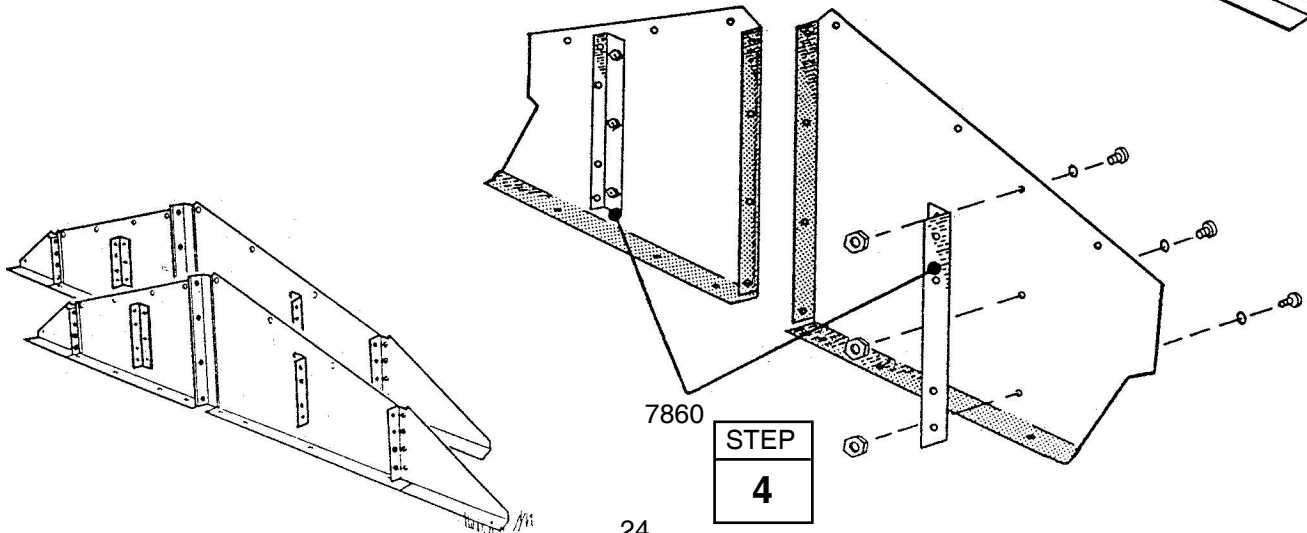

STEP
4

Step 12

ST25

● Parts Needed For ● Gables/Roof Beams

- Left Gable Assemblies (2)
- Right Gable Assemblies (2)
- Single Roof Beam Assemblies (4)
- 6636 Gable Brace (2)

1 Lift and fasten a right and left gable, under angle at corner, to the door track and rear wall angle with screws.

Hint: On the front gable, leave out 2 screws closest to center gable leg. On the rear gable, use a bolt and nut at the overlapping rear wall angle.

2 Fasten a **single roof beam**, *small holes on top*, to the outer gable leg and mid gable brace as shown using bolts and nuts.

Repeat Step 1 for the opposite side of building.

3 Join the **left and right gables** together with a **gable brace** using a bolt in the second hole from the bottom *only*. Do this step for both front and rear gables.

Repeat Step 2 for the opposite side of building.

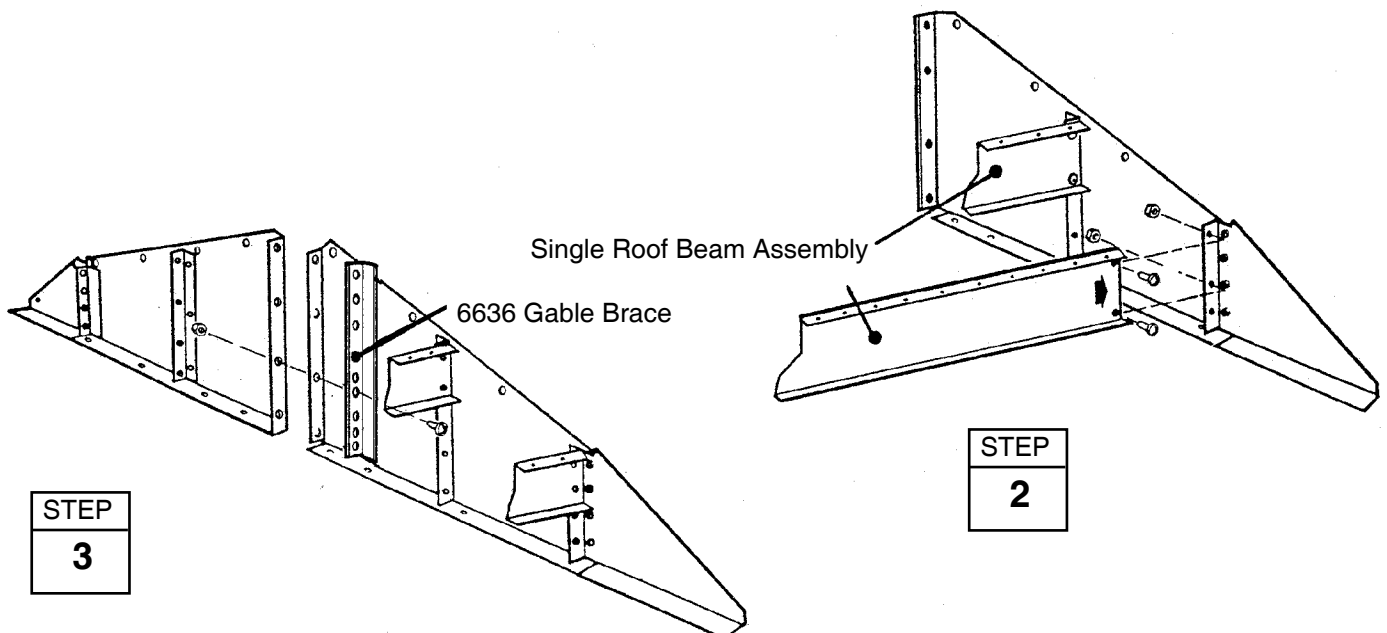
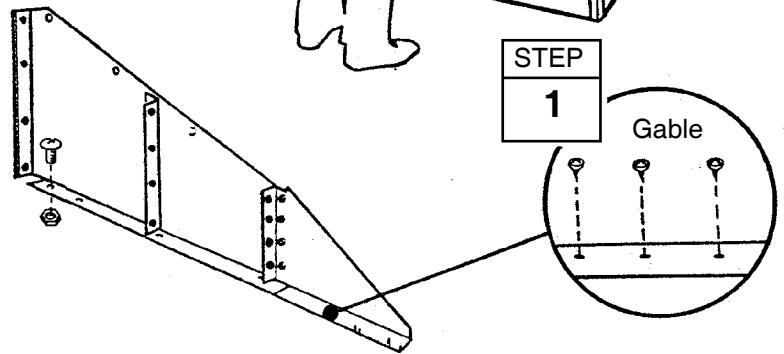

Step 13

SS26

● Parts Needed For ● Roof Beam/Braces

- Main Roof Beam Assembly (1)
- 6227 Roof Beam Brace (2)

1 Fasten the **track supports** to the front gable assembly only, as shown.

2 Wrap the **weather stripping** along the mating edge of the large left and right gables as shown. Cut the weather stripping to length.

3 Spread the two halves of the double roof beam and fasten to the gable brace of the front gable.

4 Fasten the other end of the double roof beam to the gable brace of the rear gable.

5 Fasten a **roof beam brace** to the double roof beam behind the front gable by placing the tab on the end of the brace *between* the roof beams. Align the tab with the *second* hole and fasten the brace with a bolt and nut.

6 Fasten the lower end of the roof beam brace to the **track support** with a bolt and nut.

7 Fasten a **roof beam brace** between the rear gable and the roof beam at the *first* hole, as shown.

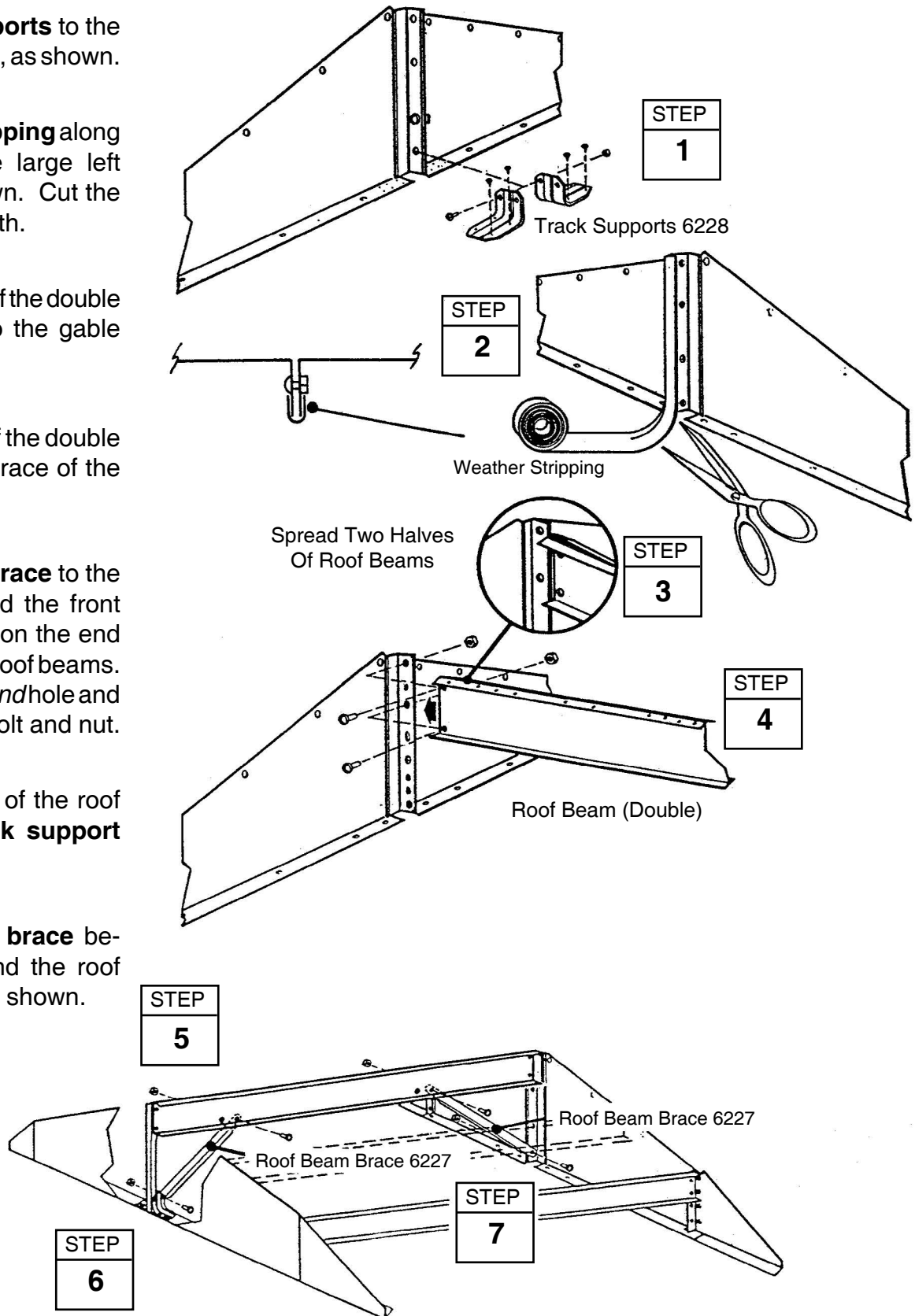

Step 14

ST27

● Parts Needed For ● Right Roof Panel

● 7862 Right Roof Panel (1)

Installing the roof panels is best done with a step ladder. Begin installing roof panels at the back right corner of the building. Each screw and bolt in the roof requires a washer.

NOTE

Measure the building diagonally again and make adjustments to make sure the building is square and level. This will make the roof panels fit better, and holes will align. Don't anchor the floor frame.

NOTE

If a **Roof Beef-Up Kit** was purchased, assemble prior to attaching the roof panels.

STEP
1

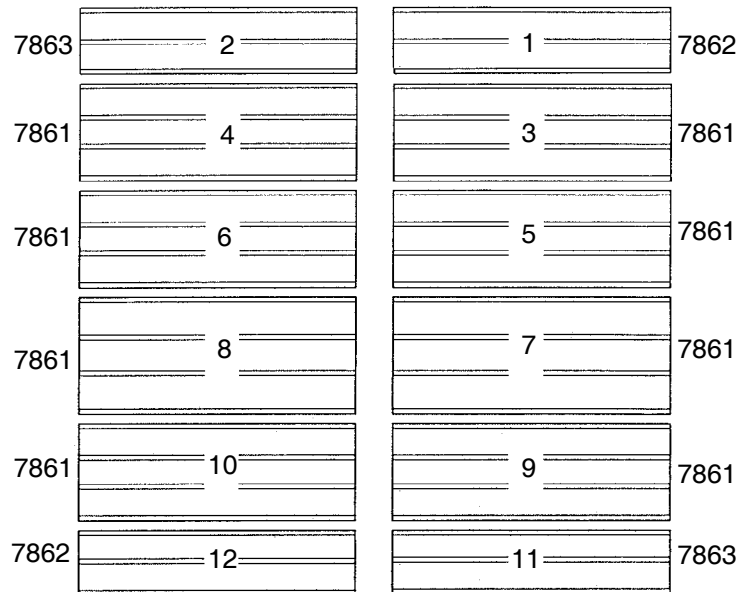

FRONT

1 Locate all the roof panels by their numbers and place them on the ground alongside the building in their proper positions.

2 Position the **right roof panel** at the back right corner and fasten to the gable and roof beams using screws and bolts as shown. *Do not fasten the lower end of the panels to the side wall angles at this time.*

Hint: Follow the fastener sequence shown, for proper alignment.

STEP
2

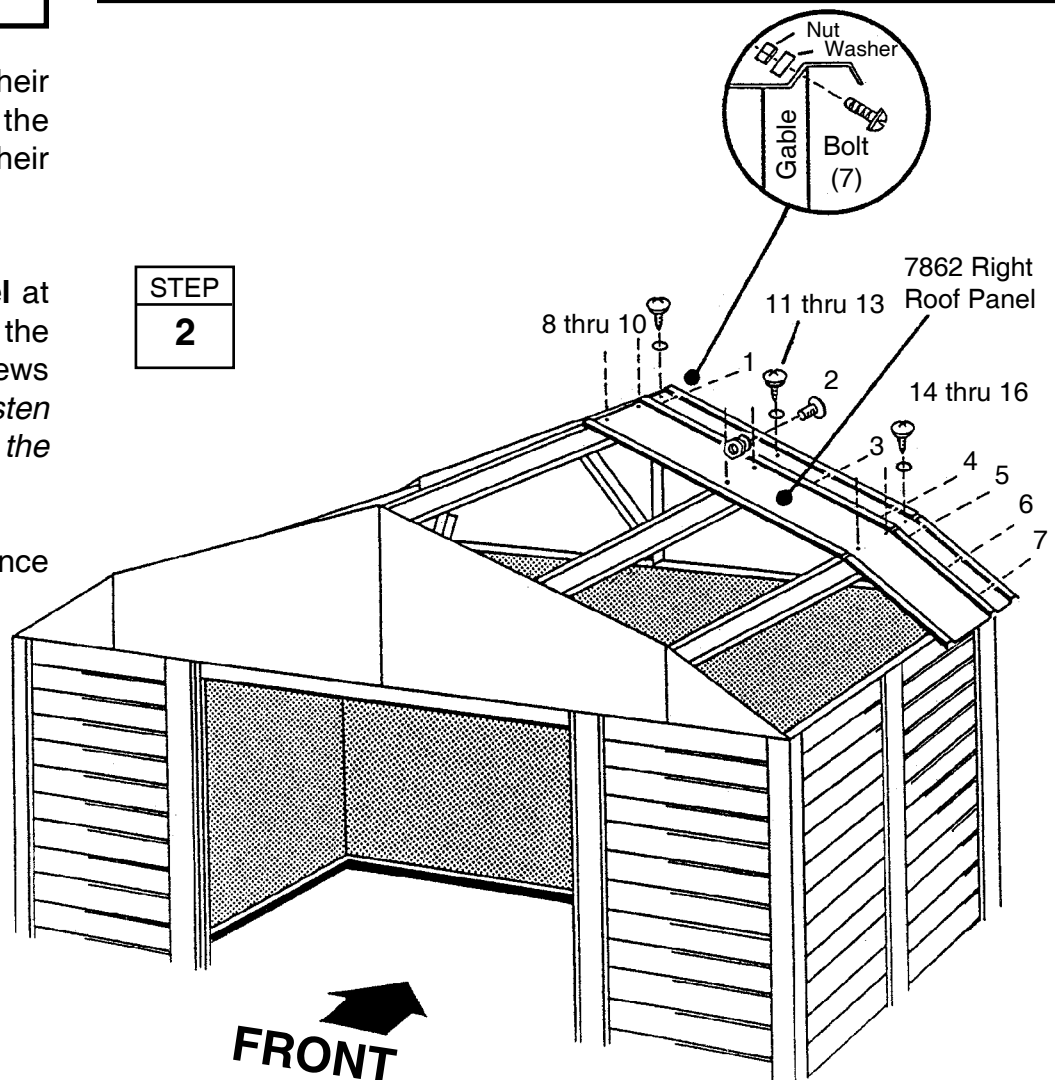

Step 15

ST28

● Parts Needed For ● Roof Assembly

- 7863 Left Roof Panel (1)
- 7861 Roof Panel (2)
- 6797 Ridge Cap (3)

1 Install a **left roof panel** at the left rear corner of the roof.

2 Install two **roof panels** in the sequence shown on previous page. Follow fastener sequence while fastening roof panels.

NOTE

Narrow roof panel rib (with bead on it) is always overlapped by wide rib of adjacent panel.

3 Cover the joint at the peak with weather stripping tape (large roll). Unroll the tape and press it down over the opening at the ridge as you install each roof panel. Do not cut the tape until entire roof is completed.

4 Cut the **weather stripping tape** (small roll) into 34 pieces, each piece about 3" (7,6 cm) long. Fold lower portion of roof panels down. Press 10 pieces firmly over the notched areas of the roof panels.

5 Install three **ridge caps 6797** on the roof section using bolts and nuts.

6 Fasten the roof panel ribs, **peak caps** and ridge caps together using bolts and nuts.

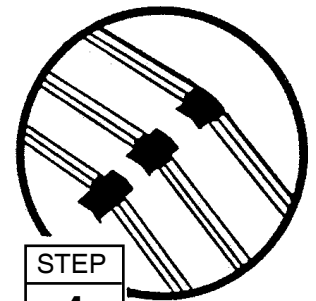
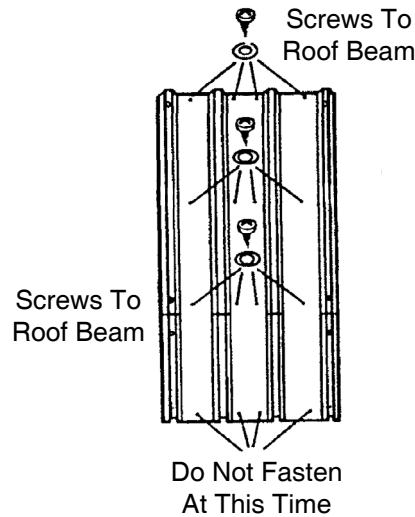

STEP
4

Weather Stripping Tape

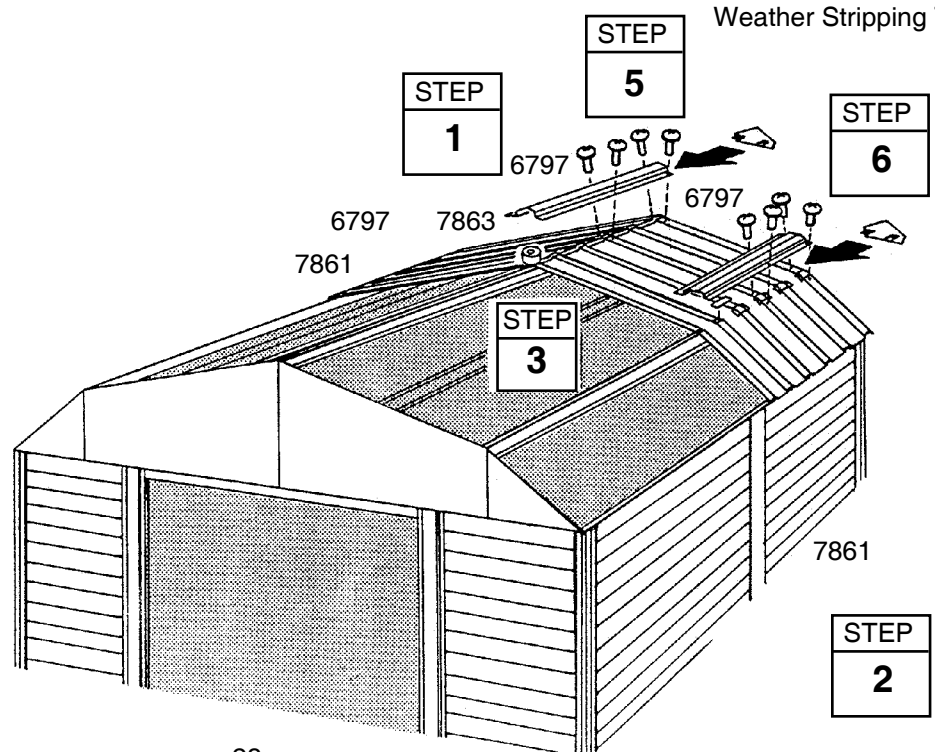

Step 16

ST29

● Parts Needed For ● Roof Assembly

- 7861 Roof Panel (4)
- 6869 Ridge Cap (3)

1 Install two **roof panels 7861** working side to side. Cover the notched areas of the roof panels with strips of weather stripping tape and continue weather stripping the ridge.

2 Install the second **ridge caps 6869** overlapping the first ridge caps.

Hint: The bolts on the ridge cap need to be left loose to move the ridge cap to the side and overlap the ribs of the next roof panel.

3 Install two **roof panels 7861** as before working side to side while fastening down ridge caps.

NOTE

If roof beam holes do not line up with the roof panel holes, shift the building from left to right. If this does not help, your building may not be level. Shim the corners until holes line up.

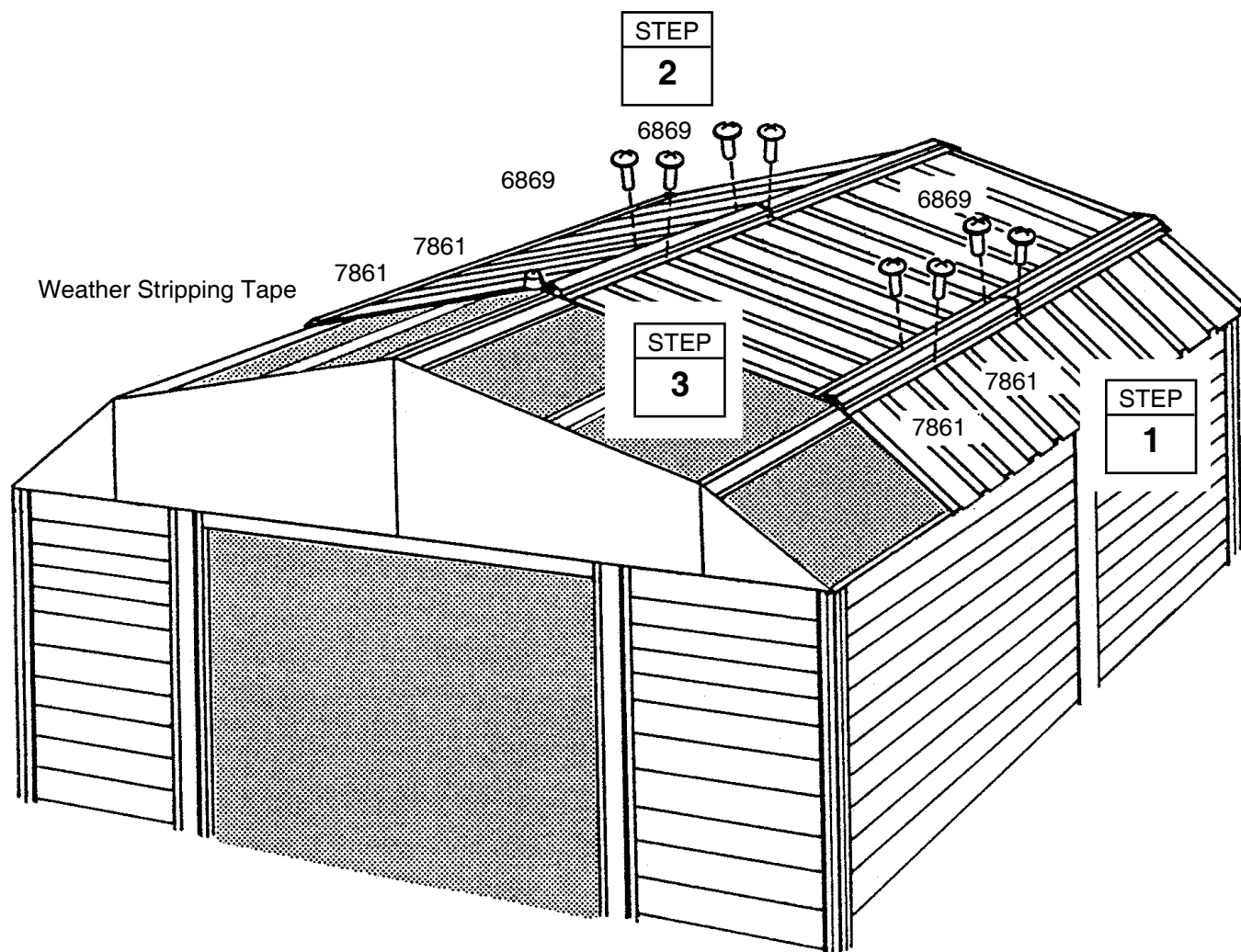

Step 17

ST30

● Parts Needed For ● Roof Assembly

- 7861 Roof Panel (2)
- 7863 Left Roof Panel (1)
- 6797 Ridge Cap (3)
- 7862 Right Roof Panel (1)

1 Install two **roof panels**, **left roof panel**, three **ridge caps 6797** and **right roof panel** on the front of the roof as before.

2 Fasten the roof panel ribs, **peak caps** and ridge caps together using bolts and nuts.

3 Fasten the lower end of the panels to the side wall angles using screws and washers.

Reducing Large Gable Bulge

Loosen eight bolts and nuts shown. Apply pressure with one hand at the peak of the gable and tighten bolt #1. Keeping pressure on the gable work down the slope tightening each bolt. Excess material will overlap smaller gable at seam. Once material bulge is worked out tighten four vertical bolts that connect the large and small gables.

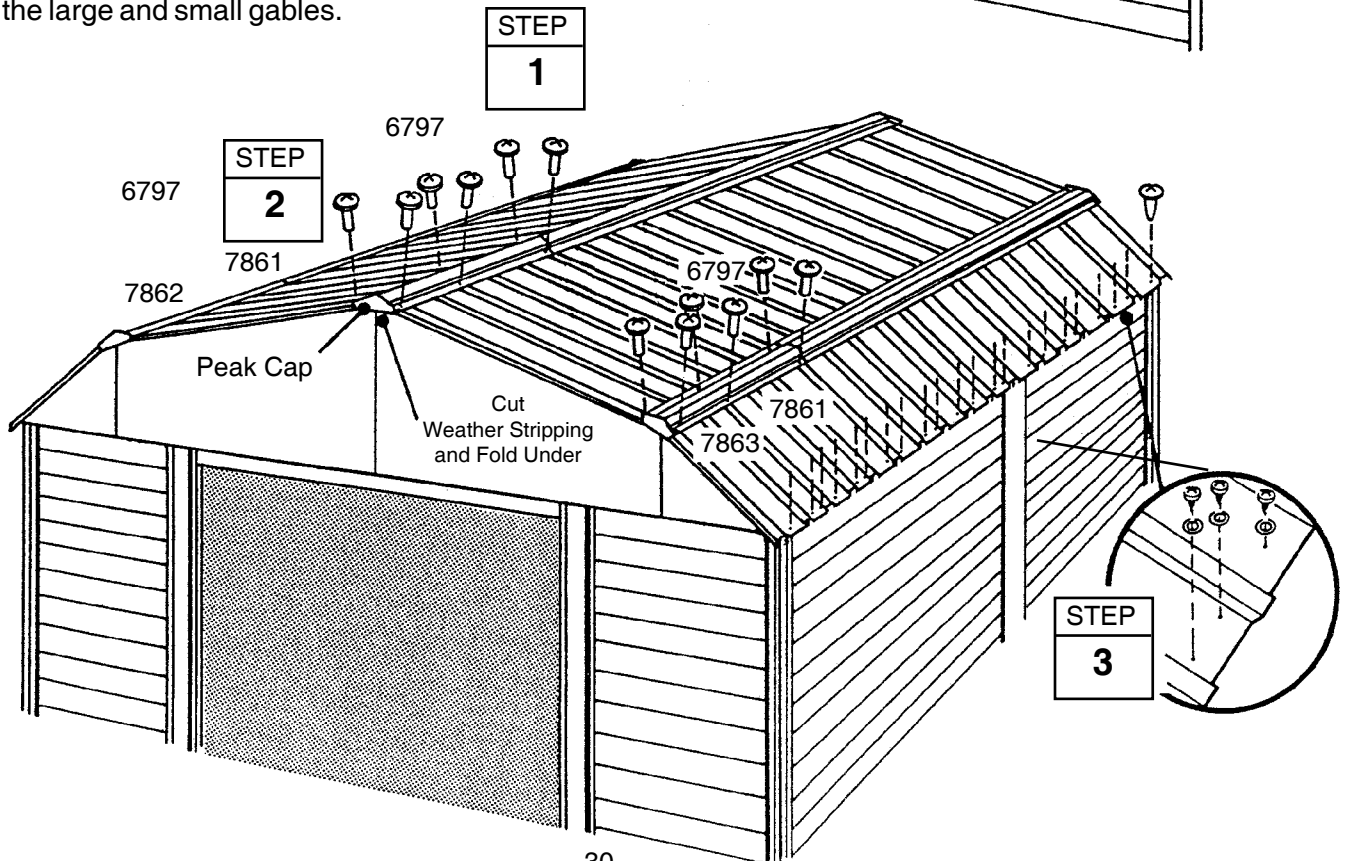
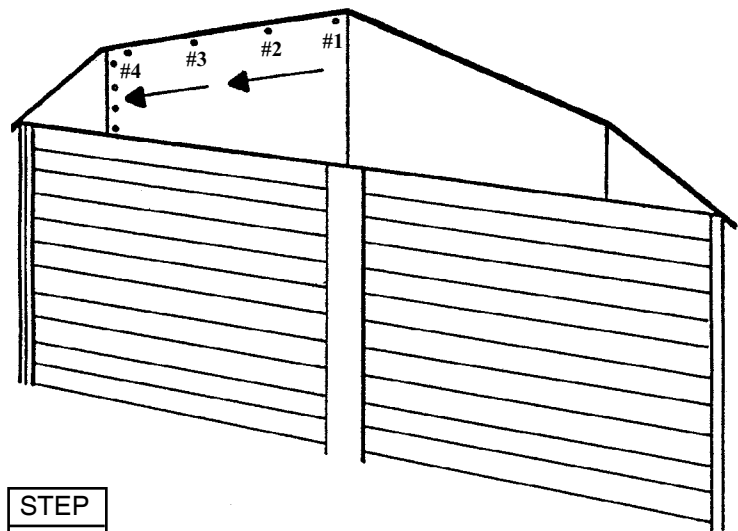

Step 18

ST31

● Parts Needed For ● Roof Trim

- 6893 Left Side Roof Trim (2)
- 6892 Right Side Roof Trim (2)
- 6015 Side Roof Trim (2)

1 Attach the **right and left side roof trim** to the lower end of the roof panels on each side of the building using screws at each panel overlap.

NOTE

A single screw fastens both trim pieces at the overlap.

2 Using your thumb and index finger, overbend the bottom flange of the side roof trim at the corner inward enough so the right and left roof trim caps fit onto right and left corners.

3 Fasten the roof trim caps to the side trim using a screw.

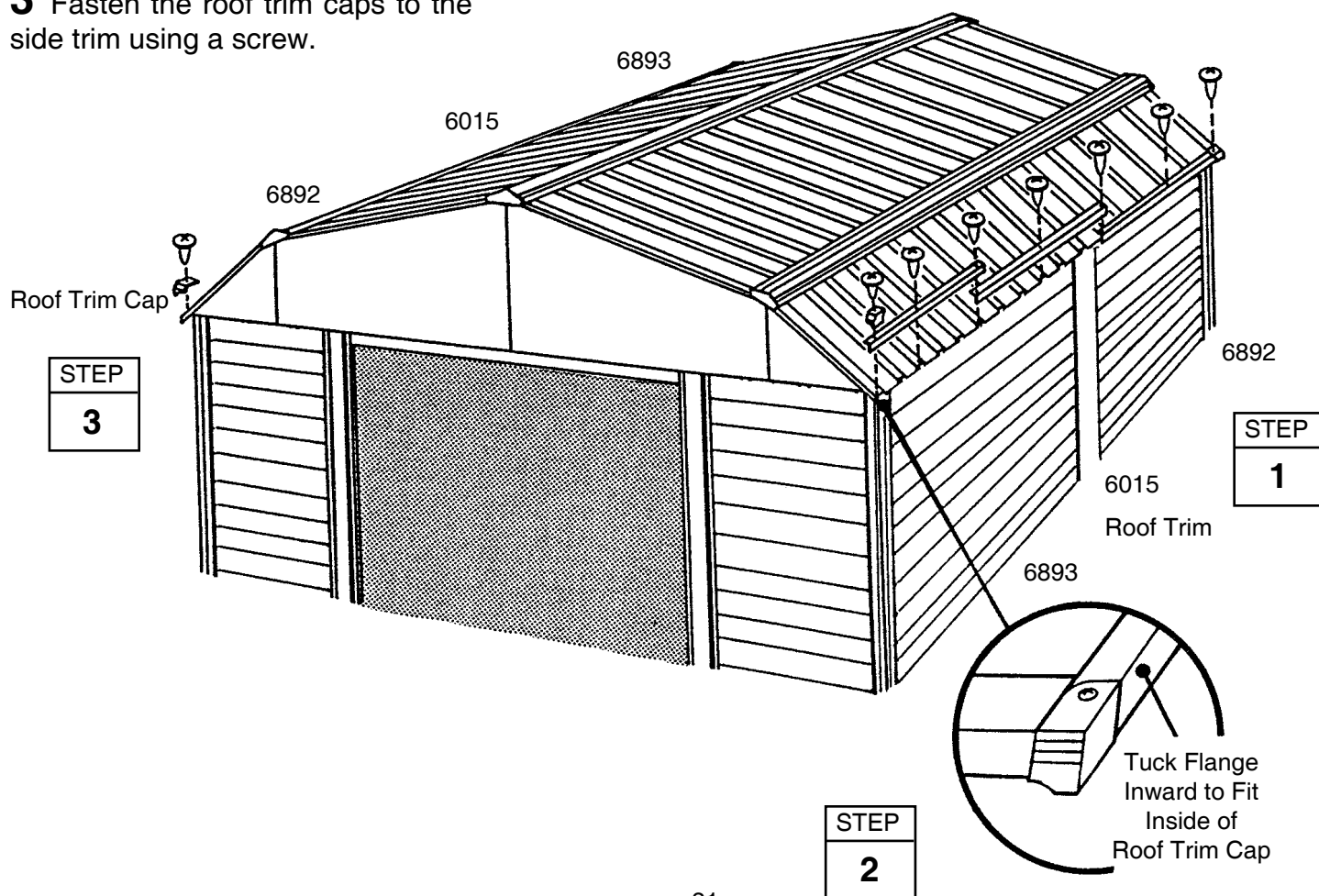

Step 19

ST32

● Parts Needed For ● Door Assembly

- 67730 Foam Board (2)
- 10509 Right and Left Doors (2)
- 10501 Horizontal Door Brace (4)
- 8109 Vertical Door Brace (2)

The steps on this page tell how to assemble the left door. You will perform exactly the same procedures for the right door. Each bolt requires a small washer on the outside of the door. Proceed as follows:

1 Place **foam board** under the lip of door.

2 Hold the **vertical door brace** against the long edge of the foam board inside the door and fasten to door using 5 bolts and nuts.

3 Put a **horizontal door brace** onto the top edge and bottom edge, covering edge of foam board, and fasten with 1 bolt in the center.

4 Attach the **lower door guides and bolts** as shown.

5 Push 7 holes through foam board where shown, using an awl or nail.

6 Fasten center of door and install **handle** using 7/8" (22 mm) bolts, door washers, hex nuts and acorn nuts.

7 Repeat steps 1 through 6 for the **right door**.

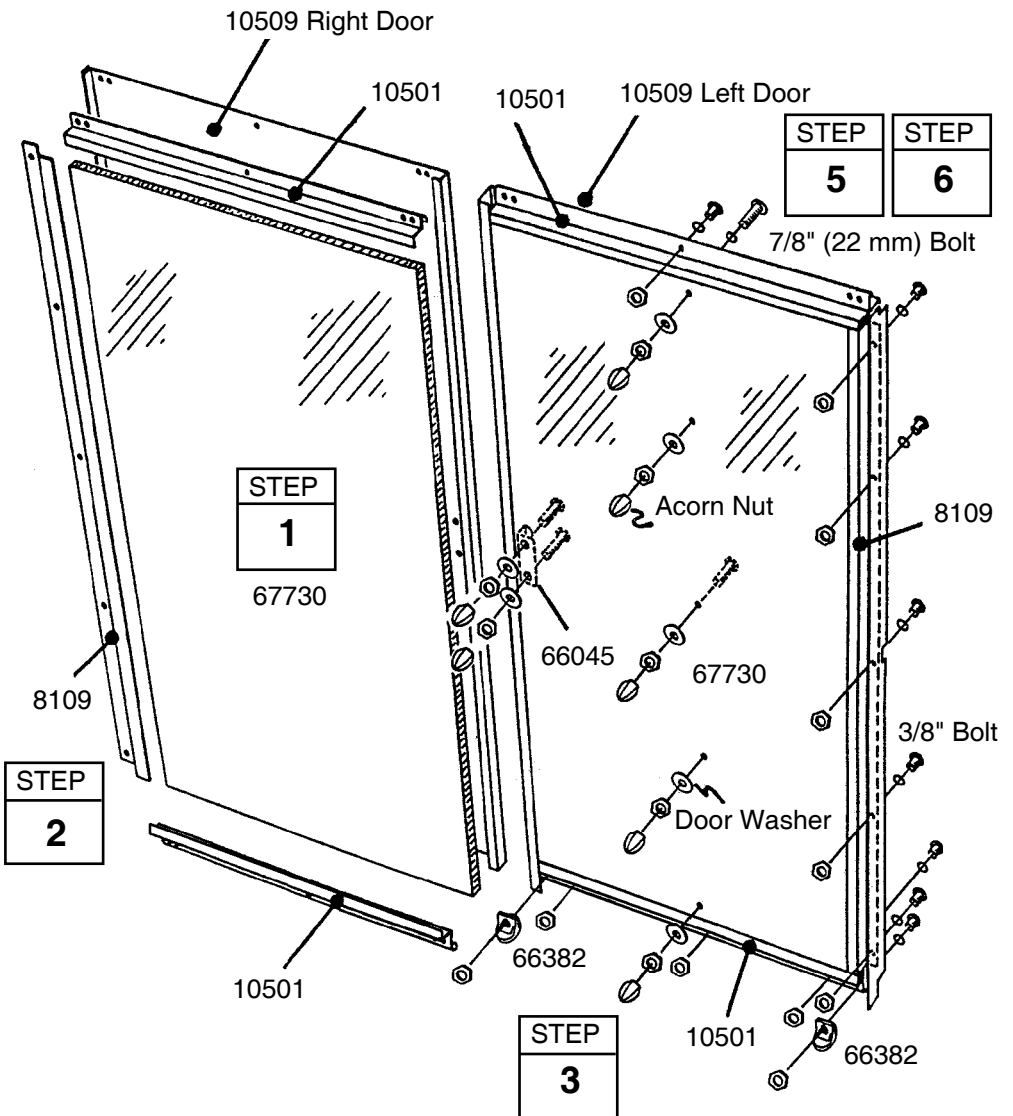

STEP
2

STEP
1

STEP
3

STEP
5

STEP
6

END VIEW
SHOWING:

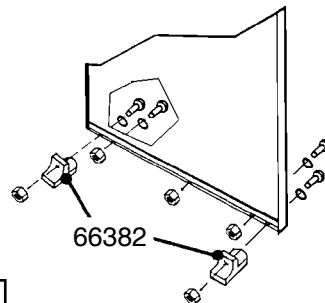

STEP
4

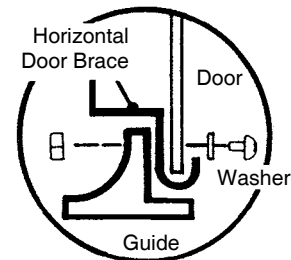

Step 20

ST33

● Parts Needed For ● Door Installation & Adjustment

- Right Door Assembly (1)
- Left Door Assembly (1)

1 From inside the building, put the bottom of the right door assembly (on your left when you are inside the building) behind door jamb into the front frame track.

2 Position the top of the door so that the holes in the door line up with the holes in the door slides.

3 Fasten the door to the door slides using two #10Bx1/2" (13 mm) screws per door slide.

NOTE

The holes in the door slides allow you to adjust the doors. Place the door in the middle holes.

4 Repeat steps 1 through 3 for the left door.

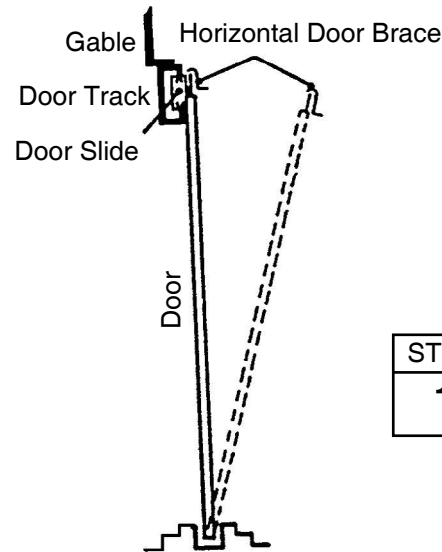

STEP
1

STEP
2

Front Floor Frame Assembly

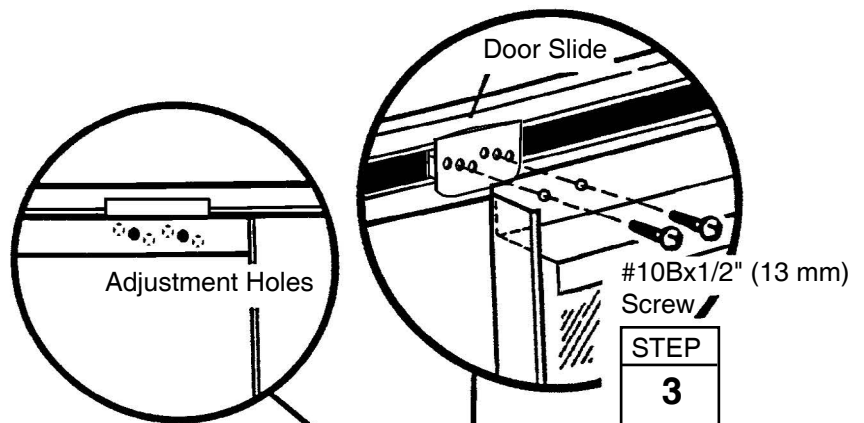

Adjustment Holes Allow
Doors to Meet Evenly
Along Their Length

**Keep this Owner's Manual and
Assembly Instructions for future
reference.**

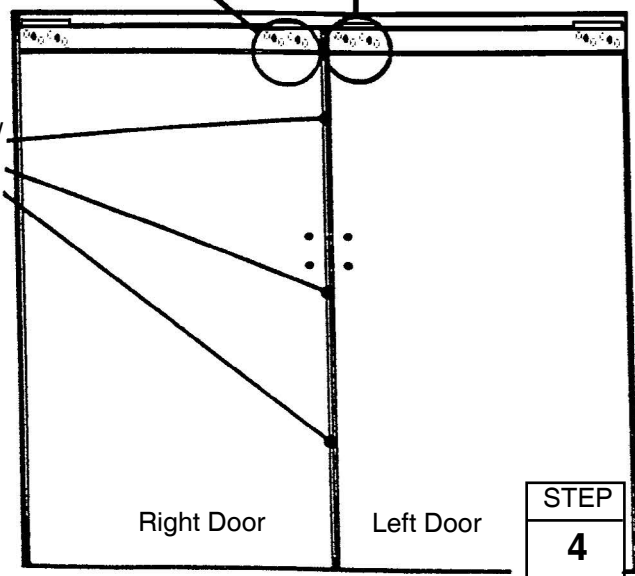

SOME FACTS ABOUT RUST

SO34

SOME FACTS ABOUT RUST

Rusting is a natural oxidizing process that occurs when bare metal is exposed to moisture. Problem areas include screw holes, unfinished edges, or where scrapes and nicks occur in the protective coating through normal assembly, handling and use. Identifying these natural rusting problem areas and taking some simple rust protection precautions can help to stop rust from developing, or stop it quickly as soon as it appears.

1. Avoid nicking or scraping the coating surface, inside and out.
2. Use all the washers supplied. In addition to protecting against weather infiltration, the washers protect the metal from being scraped by the screws.
3. Keep roof, base perimeter and door tracks free of debris and leaves which may accumulate and retain moisture. These can do double damage since they give off acid as they decay.
4. Touch up scrapes or nicks and any area of visible rust as soon as possible. Make sure the surface is free of moisture, oils, dirt or grime and then apply an even film of high quality touch-up paint.

WH1014-D1

ST36

