



Mini Excavator

Owner's Manual



WARNING: Read carefully and understand all OPERATING INSTRUCTIONS before operating. Failure to follow the safety rules and other basic safety precautions may result in serious personal injury.

Item #960999

READ & SAVE THESE INSTRUCTIONS

Thank you very much for choosing a NorTrac™ product!

For future reference, please complete the owner's record below:

Serial Number/Lot Date Code: _____

Purchase Date: _____

Save the receipt, warranty, and this manual. It is important that you read the entire manual to become familiar with this product before you begin using it.

This dozer is designed for certain applications only. Northern Tool and Equipment is not responsible for issues arising from modification or improper use of this product such as an application for which it was not designed. We strongly recommend that this product not be modified and/or used for any application other than that for which it was designed.

For product assistance, service, and warranty questions, please contact NorTrac Technical Support **1-800-521-0438**.

Table of Contents

Intended Use.....	4
Technical Specifications	4
Important Safety Information	4
Safety and Product Labels	9
Before Each Use.....	11
Operating Instructions.....	19
After Each Use.....	53
Maintenance	53
Troubleshooting.....	96
Parts Diagram	99
Parts List.....	100
Replacement Parts.....	100
Limited Warranty.....	101

Intended Use

The Mini Excavator is a small excavator based on mining operation and lifting loading and unloading operation. The design structure is compact, the dynamic matching is appropriate, the product has good stability. It can meet the mining and loading and unloading requirements under the different operating conditions of the plain, hilly and forest areas. It is also suitable for brick and tile factory, kiln plant, river course, building, dredging and road construction. It is the most ideal construction machine for farmland operation and small engineering.

Technical Specifications

Property	Specification
Engine	YANMAR
Fuel Capacity (gal.)	4.76 gallon
Bucket Capacity (lbs.)	11.89 gallon
Ground Clearance (in.)	17.2"
Max. Width (in.)	43.7"
Engine Type	Diesel
Cylinders (qty.)	3
Bore x Stroke (in.)	2.91*3.03"
Radiator (gal. (qt.))	1.32gallon

Specifications and design subject to change without notice.

Important Safety Information

⚠️WARNING

- Read and understand all instructions. Failure to follow all instructions may result in serious injury or property damage.
- The warnings, cautions, and instructions in this manual cannot cover all possible conditions or situations that could occur. Exercise common sense and caution when using this excavator. Always be aware of the environment and ensure that the excavator is used in a safe and responsible manner.
- Do not allow persons to operate the Mini Excavator they have read this manual and have developed a thorough understanding of how it works.
- Do not modify this machine in any way. Unauthorized modification may impair the function and/or safety and could affect the life of the product and void the warranty. There are specific applications for which the product was designed.
- Use the right tool for the job. DO NOT attempt to force small equipment to do the work of larger industrial equipment. There are certain applications for which this equipment was designed. This product will be safer and do a better job at the capacity for which it was intended. DO NOT use this equipment for a purpose for which it was not intended.
- Industrial or commercial applications must follow OSHA requirements.

⚠️WARNING

WORK AREA SAFETY

- Inspect the work area before each use. Keep work area clean, dry, free of clutter, and well-lit. Cluttered, wet, or dark work areas can result in injury. Using the product in confined work areas may put you dangerously close to cutting tools and rotating parts.
- Do not use the product where there is a risk of causing a fire or an explosion; e.g., in the presence of flammable liquids, gases, or dust. The product can create sparks, which may ignite the flammable liquids, gases, or dust.
- Keep children and bystanders away from the work area while operating the excavator. Do not allow children to handle the product.
- Be aware of all power lines, electrical circuits, water pipes, and other mechanical hazards in your work area. Some of these hazards may be hidden from your view and may cause personal injury and/or property damage if contacted.

⚠WARNING

PERSONAL SAFETY

- Stay alert, watch what you are doing, and use common sense when operating the excavator. Do not use the excavator while you are tired or under the influence of drugs, alcohol, or medication. A moment of inattention while operating the excavator may result in serious personal injury or death.
- Dress properly. Do not wear loose clothing, dangling objects, or jewelry. Keep your hair, clothing and gloves away from moving parts. Loose clothes, jewelry, or long hair can be caught in moving parts. Air vents on the excavator often cover moving parts and should be avoided.
- Wear the proper personal protective equipment when necessary. Use ANSI Z87.1 compliant safety goggles (not safety glasses) with side shields, or when needed, a face shield. Use a dust mask in dusty work conditions. Also use non-skid safety shoes, hardhat, gloves, dust collection systems, and hearing protection when appropriate. This applies to all persons in the work area.
- Do not overreach. Keep proper footing and balance at all times.
- Secure the work with clamps or a vise instead of your hand when practical. This safety precaution allows for proper excavator operation using both hands.
- Engine exhaust contains carbon monoxide, an odorless, deadly poison that can kill you. Do not run the engine indoors or in an enclosed area.

⚠CAUTION

MINI-EXCAVATOR USE AND CARE

- Do not force the product. Products are safer and do a better job when used in the manner for which they are designed. Plan your work and use the correct product for the job.
- Check for damaged parts before each use. Carefully check that the product will operate properly and perform its intended function. Replace damaged or worn parts immediately. Never operate the product with a damaged part.
- Do not use a product with a malfunctioning switch. Any power tool that cannot be controlled with the power switch is dangerous and must be repaired by an authorized service representative before using.
- Disconnect the power/air supply from the product and place the switch in the locked or off position

before making any adjustments, changing accessories, or storing the excavator. Such preventive safety measures reduce the risk of starting the excavator accidentally.

- Store the product when it is not in use. Store it in a dry, secure place out of the reach of children. Inspect the excavator for good working condition prior to storage and before re-use.
- Use only accessories that are recommended by the manufacturer for use with your product. Accessories that may be suitable for one product may create a risk of injury when used with another excavator. Never use an accessory that has a lower operating speed or operating pressure than the excavator itself.
- Keep guards in place and in working order. Never operate the product without the guards in place.
- Do not leave the excavator running unattended.

⚠WARNING

TRAINING

- Read the Owner's Manual and other training material. If the operator(s) or mechanic(s) cannot read English, it is the owner's responsibility to explain this material to them.
- Become familiar with the safe operation of the equipment, operator controls, and safety signs.
- All operators and mechanics should be trained. The owner is responsible for training the users.
- Never let children or untrained people operate or service the equipment. Local regulations may restrict the age of the operator.
- The owner/user can prevent and is responsible for accidents or injuries occurring to himself or herself, other people or property.

⚠WARNING

PREPARATION

- Evaluate the terrain to determine what accessories and attachments are needed to properly and safely perform the job. Only use accessories and attachments approved by the manufacturer.
- Wear appropriate clothing including gloves, safety glasses, long pants, substantial slip-resistant footwear, and hearing protection. Tie back long hair and do not wear jewelry.
- Inspect the area where the equipment is to be used and remove all objects such as rocks, toys, and wire which can be thrown by the machine.
- Use extra care when handling fuels. They are flammable, and vapors are explosive.
 - Use only an approved fuel container
 - Never remove the fuel cap or add fuel with the engine running. Allow the engine to cool before refueling. Do not smoke.
 - Never refuel or drain the machine indoors.
- Check that the operator's presence controls, safety switches, and shields are attached and functioning properly. Do not operate unless they are functioning properly.

⚠WARNING

OPERATION

- Only operate in good light, keeping away from holes and hidden hazards.
- Be sure all drives are in neutral before starting the engine. Only start the engine from the operator's position.
- Do not operate any of the control levers (including auxiliary lever) unless you are sitting with both feet on the platform and firmly holding the grip handles.
- Slow down and use extra care on hillsides. Be sure to travel in the recommended direction on hillsides. Turf conditions can affect the machine's stability.
- Slow down and use caution when making turns, crossing roads and sidewalks, and changing directions on slopes.
- Never operate without the guards securely in place. Be sure all interlocks are attached, adjusted, and functioning properly.
- Do not change the engine governor setting or overspeed the engine.
- Stop on level ground, lower implements, disengage the auxiliary hydraulics and shut off the engine before leaving the operator's position for any reason.
- Keep hands and feet away from moving attachments.
- Look behind and down before backing up to be sure of a clear path.
- Never carry passengers and keep pets and bystanders away.
- Slow down and use caution when making turns and crossing roads and sidewalks.
- Do not operate the machine when you are tired, ill, or under the influence of alcohol or drugs.
- Use care when loading or unloading the machine into a trailer or truck.
- Use care when approaching blind corners, shrubs, trees, or other objects that may obscure vision.
- Read all attachment manuals.
- Ensure that the area is clear of other people before operating the loader unit. Stop the excavator if anyone enters the area.
- Never leave a running excavator unattended. Always lower the loader arms, stop the engine, set the parking brake, and remove the key before leaving.
- Do not exceed the rated operating capacity, as the excavator may become unstable which may result in loss of control.
- Do not carry a load with the bucket raised. Always carry loads close to the ground.
- Do not overload the attachment and always keep the load level when raising the loader arms. Logs, boards, and other items could roll down the loader arms, injuring you.
- Never jerk the controls; use a steady motion.
- Watch for traffic when operating near or crossing roadways.
- Do not touch parts which may be hot from operation. Allow them to cool before attempting to maintain, adjust, or service.
- Check for overhead clearances (i.e., branches, doorways, electrical wires) before driving under any objects and do not contact them.
- Ensure that you operate the loader unit in areas where there are no obstacles in close proximity to

the operator. Failure to maintain adequate distance from trees, walls, and other barriers may result in injury. Only operate the unit in areas where there is sufficient clearance for the operator to safely maneuver the product.

- Before digging, have the area marked for underground utilities, and do not dig in marked areas. Also, be aware of the location of objects and structures that may not be marked, such as underground storage tanks, wells, and septic systems.
- Locate the pinch point areas marked on the loader unit and attachments and keep hands and feet away from these areas.
- Before operating the loader unit with an attachment, ensure that the attachment is properly installed and a genuine NorTrac-approved attachment.
- Lightning can cause severe injury or death. If lightning is seen or thunder is heard in the area, do not operate the machine; seek shelter.

⚠WARNING

SLOPE OPERATION

- Do not operate on slopes exceeding 15°. If the slope is greater than 5°, only go up and down (not across).
- Operate up and down slopes with the heavy end of the excavator uphill. Weight distribution changes. An empty bucket will make the rear of the loader unit the heavy end, and a full bucket will make the front of the loader unit the heavy end. Most other attachments will make the front of loader unit the heavy end.
- Raising the bucket on a slope will affect the stability of the machine. Whenever possible, keep the bucket in the lowered position when on slopes. Remove obstacles such as rocks, tree limbs, etc. from the work area. Watch for holes, ruts, or bumps, as uneven terrain could overturn the excavator. Tall grass can hide obstacles.
- Use only NorTrac-approved attachments. Attachments can change the stability and the operating characteristics of the loader unit. Warranty may be voided if used with unapproved attachments.
- Keep all movements on slopes slow and gradual. Do not make sudden changes in speed or direction.
- Avoid starting or stopping on a slope. If the loader unit loses traction, proceed slowly, straight down the slope.
- Avoid turning on slopes. If you must turn, turn slowly and keep the heavy end of the loader unit uphill.
- Do not operate near drop-offs, ditches, or embankments. The loader unit could suddenly turn over if a track goes over the edge of a cliff or ditch, or if an edge caves in.
- Use caution when operating on wet grass. Reduced traction could cause sliding.
- Do not park the loader unit on a hillside or slope without lowering the attachment to the ground and chocking the tracks.

Safety and Product Labels

Reference Number	Description	Quantity
01	Warning label	2
02	Warning label	1
03	Other label	1
04	Other label	4
05	Warning label	1
06	Warning label	2
07	Warning label	1
08	Other label	1
09	Warning label	2
10	Danger	1
11	Instructional Label	1
12	Warning label	1
13	Other Label	1
14	Instructional Label	1
15	Spec Label	1
16	Logo Label	1
17	Warning label	1
18	Warning label	1
19	Warning label	1
20	Warning label	1
21	Warning label	1

1. 

▲WARNING

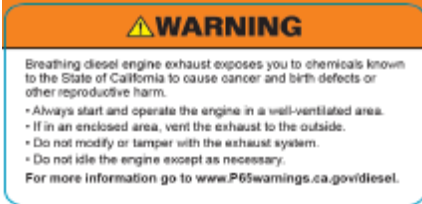

CRUSH HAZARD
Keep clear from under the bucket and loader arms.
2. 

▲WARNING

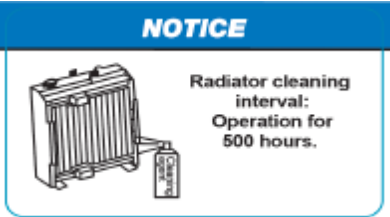

Breathing diesel engine exhaust exposes you to chemicals known to the State of California to cause cancer and birth defects or other reproductive harm.

 - Always start and operate the engine in a well-ventilated area.
 - If in an enclosed area, vent the exhaust to the outside.
 - Do not modify or tamper with the exhaust system.
 - Do not idle the engine except as necessary.

For more information go to www.P65warnings.ca.gov/diesel.
3. 

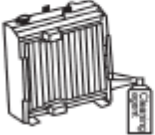
NOTICE



Radiator cleaning interval:
Operation for 500 hours.
4. 

▲WARNING

To prevent personal injury or death:
Before operating the excavator, know the location of the dozer blade. The excavator will travel in the direction of the dozer blade when drive levers are moved away from the operator.

5.

▲WARNING

To release pressure, loosen only one turn. If the valve is loosened too much, grease under high pressure may squirt out.

6.

▲WARNING

VEHICLE FREQUENTLY REVERSING

7.

NOTICE

To prevent damage to the excavator, the hydraulic oil temperature must be warmed to 77 F.

1. Run the engine at low idling for 3 minutes.
2. Increase idling and cycle the bucket level for 3 minutes.
3. Run the engine at high idling and cycle the boom lever, bucket lever, arm lever, swing and traveling. Cycle the excavator several times in each all directions to ensure hydraulic oil temperature is above 77 F.

8.

▲WARNING

CRUSH HAZARD
Keep clear from the operating area.

9.

▲DANGER

FIRE HAZARD
Do not fuel at the work site. Fuel the machine on a hard, level surface. Keep open flames and sparks away from the machine while fueling. Do not smoke while fueling. Do not fill beyond the correct marking. Expansion of fuel from a leak of fuel or normal operation may cause tank spillage if overfilled. Clean up any fuel spills before starting engine.

FUEL (DIESEL)

10.

HYDRAULIC OIL
ISO 46
Oil change interval:
Operation for 2000
hours or 1 year

11.

▲WARNING

FALL HAZARD
Wear seatbelt at all times.

▲WARNING

Do not operate on slopes greater than 15 degrees. Operate on slopes greater than 15 degrees only when necessary. Do not operate on slopes greater than 15 degrees unless the operator is wearing a seatbelt. Do not operate on slopes greater than 15 degrees unless the operator is wearing a seatbelt. Do not operate on slopes greater than 15 degrees unless the operator is wearing a seatbelt. Do not operate on slopes greater than 15 degrees unless the operator is wearing a seatbelt.

▲DANGER

ELECTROCUTION HAZARD
Do not touch or stand on metal parts of the machine or back seatbelt attachment while working on the machine. Do not touch or stand on metal parts of the machine or back seatbelt attachment while working on the machine. Do not touch or stand on metal parts of the machine or back seatbelt attachment while working on the machine.

12.

12V

13.

CONTROLS

FORWARD
REVERSE
SWING LEFT
SWING RIGHT
UPPER ARM
LOWER BOOM
DUMP
RAISE BOOM

14.

Mini Excavator

Model: _____ Capacity (cu. ft.): _____
 Power (HP): _____ Max Speed (mph): _____
 Engine: _____ Weight (lb.): _____
 Production Date: _____ Serial No.: _____

15.

NORTRAC 16MXD

16.



Before Each Use

⚠WARNING

- You have the responsibility to follow the safety regulations and laws of the departments concerned, and operate, inspect and maintain machines according to the manufacturer's requirements.
- In fact, all accidents sometimes result from failure to comply with basic safety regulations and precautions. Most accidents can be avoided by identifying potential hazards in advance.

Please read and understand all safety information that describes how to prevent accidents. Do not operate the machine until you know how to operate, check and maintain the machine correctly.

Compliance with all safety regulations

Trained and qualified personnel must be operated, inspected and maintained.

When machine operation, inspection and maintenance are carried out, all rules, regulations, precautions and safety measures must be understood and observed.

Do not operate, check and maintain machines when alcohol, drugs, drugs, fatigue or sleep are not enough.

When the machine is found to be abnormal

In the operation or inspection and maintenance of the machine, if the machine is found to be abnormal (noise, vibration, odor, oil leakage, error alarm, etc.), the sales or service agent should be immediately informed and appropriate measures should be taken. Do not operate the machine until the exception is excluded.

Operating temperature range

In order to maintain the performance of the machine and avoid premature wear, please observe the following operating conditions.

Do not operate the machine if the outdoor temperature is above +113°F or below 5°F.

If the outdoor temperature exceeds +113°F, the operation of the engine may overheat, resulting in the decline of the engine's oil capability. Moreover, the hydraulic oil may become very hot, which will cause damage to the hydraulic equipment.

If the outdoor temperature is below 5°F, the rubber parts such as gaskets may harden, causing the machine to wear or damage too early.

If you need to operate the machine outside the above temperature range, please consult your sales or service agent.

Wear suitable clothes and protective equipment



Do not wear loose clothing or ornament that may hang control rods or moving parts.

Do not wear clothes that are easily ignited with oil or fuel stains.

According to the requirements of working environment, wear safety shoes, safety helmet, safety glasses, filter mask, thick gloves, ear protectors and other protective equipment. When using a grinder, a crushing hammer, or a compressed air, appropriate protective equipment, such as a safety goggles and a filter mask, should be worn, because the spattering of metal or other objects may cause serious damage.

When operating the machine, please use the hearing protection device. Exposure to loud noise for a long time can cause hearing loss or even loss.

Installation of fire extinguishers and first aid cases

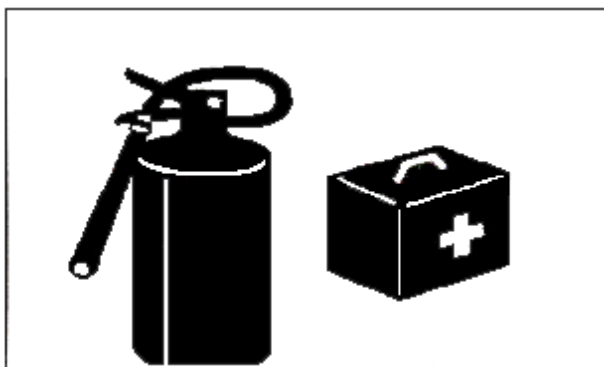

Do a good job of fire and accident preparation

Install fire extinguishers and first-aid boxes and learn how to use them.

Learn how to extinguish and deal with accidents.

Know how to contact emergency assistance and make emergency contact list.

Do not dismantle the safety device

Please ensure that all the protective barriers are installed and firmly installed. Before you operate the machine, please repair or replace the damaged parts.

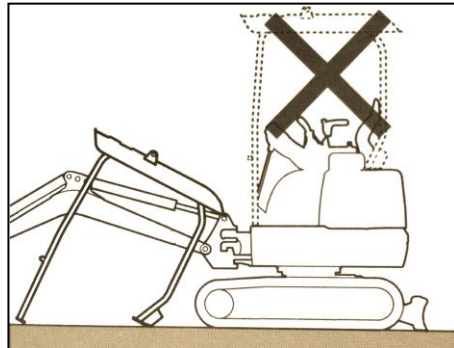

Do not remove any safety devices except for maintenance. Use all safety devices to maintain good working conditions.

Equipped with signaling and signal bearers

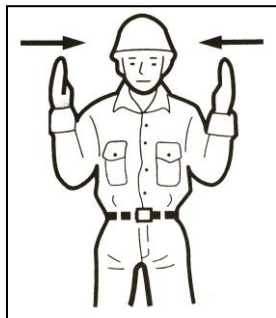

Learn how to use specific job required gestures and identify people responsible for gesturing.

All people must fully understand all the gestures.

The operator must respond to the gesture of the designated person, but must obey any stop gesture at any time.

When the signer signals, he/she must stand clearly.

Matters of attention when starting or leaving from the driver's seat

When standing up from the driver's seat, reduce the working device to the ground and stop the engine. If you touch any control handle carelessly, it will cause the machine to move and cause serious injury or death.

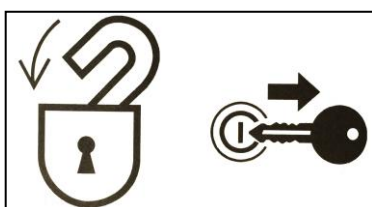

Please pay attention to the control of excavator, boom swing and auxiliary hydraulic control. Do not touch these controls.

Before leaving the cab seat, the working device should be lowered to the ground and the engine will be shut off. At the same time, please be sure to pull out the key and carry the key with you, then store it in the designated place.

Avoid fire and explosion hazards



Keep fuel, lubricating oil, grease and antifreeze away from fire sources. Fuel is very flammable and very dangerous.

When dealing with these combustibles, keep away from the lighted cigarettes, matches, lighters and other flame or fire sources.

Do not smoke or open fire when dealing with fuel or fuel system.

Do not leave the job site when fuel or lubricating oil is added.

No fuel cap or gas can be removed when the engine is running or not cooled. Also, do not splash fuel on the hot surfaces or electronic components of the machine.

Clean up the spilled oil or oil immediately.

Check the leakage of fuel and lubricating oil. Please exclude leakage and clean the machine before operation.

When polishing or welding operations, please move inflammable goods to safe place.

Do not cut or weld inside pipes or pipes that contain flammable liquids. Before cutting or welding, please use non flammable solvents to clean thoroughly.

Clean up all the garbage or sundries of the machine. Make sure that there are no oily rag or other inflammable materials on the machine.

All kinds of solvents or dry chemicals (foam extinguisher) should be disposed according to the procedure of the manufacturer's container. It is carried out in a well ventilated place.

Do not use fuel for cleaning. Non combustible solvents are always used.

Keep all flammable liquids and materials in a safe and well ventilated place.

A short circuit of an electronic system can cause a fire. Check whether the wire connection is loose or damaged every day. Re tighten loose connectors and cable buckles. Repair or replace damaged wires.

A fire caused by a pipe:

Ensure that the hose and pipe buckle, protective device and cushion are firmly secured. If there is any loosening, hoses or pipes will be damaged due to vibration or contact with other components during operation. This may cause high-pressure oil ejection, causing fire or injury.

The exhaust gas from the engine is poisonous

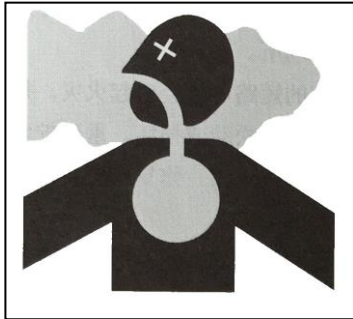

Do not operate the engine in a poorly ventilated enclosure.

If not for natural ventilation should be installed fan, fan, lengthened exhaust pipe or other ventilation devices.

Treatment of asbestos dust

Lung cancer may be caused by inhaling asbestos dust. When dealing with materials that contain asbestos, the following safety precautions should be taken.

Do not use compressed air for cleaning.

Avoid polishing or grinding parts containing asbestos.

When cleaning, please use vacuum equipment equipped with high efficiency particulate air filter.

If there is no other way to control the dust, please wear the prescribed respirator. When working indoors, please install a ventilation system equipped with polymer filter.

Please do not allow unauthorized personnel to enter the job area while doing homework.

Please strictly abide by the rules and environmental standards applicable to the operation area.

Be careful not to bruise



Do not put hands, feet, or other body parts

Between the tracks and the lower workshop or the excavator,

Between the body and the working device or the cylinder and the oil cylinder and

Between the parts of the movement. When the machine moves,

These gap sizes will change and may be made Severe injury or death.

Use an optional product

Before installing the selection, please consult Northern Tool & Equipment. According to the type of annexes or their combinations, the attachment may be exposed to other parts of the driver's machine. Make sure that the selected items are not contacted with other parts before use.

Please do not use the accessories that are not approved by Nortrac. Doing this may jeopardize safety or cause adverse effects on the operation or service life of the machine.

Northern Tool & Equipment is not responsible for any injuries, accidents or product damage caused by the use of unauthorized accessories.

Do not remould the machine

Unauthorized transformation of machine will cause injury or death. Never make any unauthorized transformation of any part of the machine.

Safety mark (logo)

In order to ensure the safety of the operators and the workers around the operation area, the following safety signs (marks) should be placed in some parts of the machine. Take this manual to walk around the machine to see the content and location of these safety signs. Review these signs and operation instructions in this manual together with your machine driver.

Safety signs should be kept clean, clear and easy to identify. If any security labels are shedding or damaged and become difficult to identify, please replace them with new labels. Please provide your product serial number when ordering the new logo from Nortrac customer service.

When the parts and bodies posted on the safety signs have been replaced, new signs should be posted on the new parts / machines.

Precautions in preparation

Understand the work area

Before starting operation, we should know the operation area to ensure safety.

Check the terrain and ground conditions in the operation area, check the building structure during indoor operation, and take safety measures when necessary.

We must avoid dangers and obstacles such as gutter, underground pipelines, trees, cliffs, overhead lines, or dangerous areas for implementation or landslide.

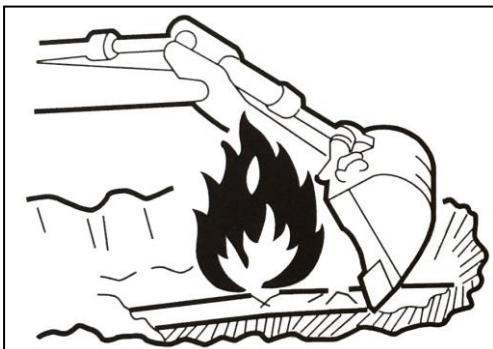

Check the location of buried gas pipe, water pipe and power cable with the administrator. If necessary, consult with the administrator and identify specific safety measures that must be taken to ensure safety.

When we are on the road, we must consider the safety of pedestrians and vehicles.

Use signalling and / or signals. The isolated operation area is not allowed to enter by unauthorized personnel.

When working in shallow water or in shallow water, we should check the depth of water, whether the ground is solid and the speed of water flow.

Check the strength of the bridge

Please check the allowable load when walking on a bridge or structure. If the strength is insufficient, we should strengthen the bridge or structure.

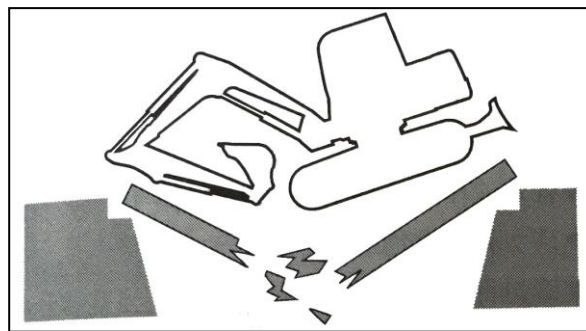

Keep the machine clean all the time

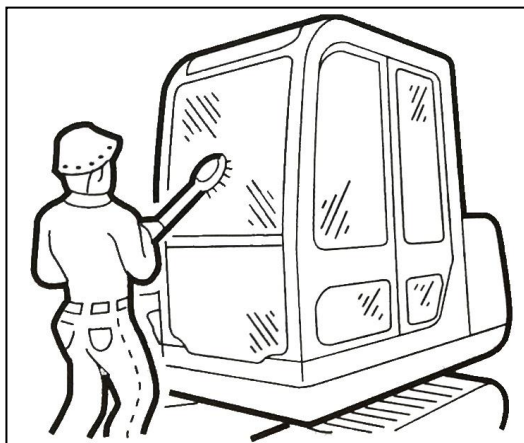

Wipe up lubricating oil, grease, soil, snow or ice to prevent accidents caused by slipping.

Clear all loose objects and unnecessary devices in the machine.

Remove dust, lubricating oil or grease from engine parts to prevent fire.

Clean the operator's seat and remove any unnecessary objects in the machine.

Daily inspection and maintenance

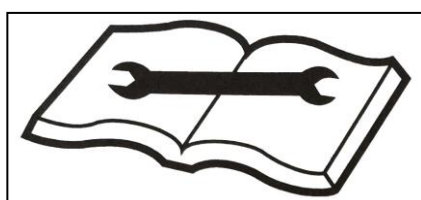

Failure or failure to find or repair the machine will cause accidents.

Before the operation, please make the specified inspection and repair immediately if necessary.

If there is an accident and can not operate or engine failure, please shut down immediately according to the shutdown procedure, and firmly park the machine until the trouble is repaired.

Cautions in the driver's room

Before driving the machine, please remove the dirt and grease from the sole. When the dirt and grease are adhered to the sole, operating machine pedals will cause accidents due to slippage at the foot.

Do not place parts or tools around the driver's seat.

Do not place any plastic bottles in the driver's space. Plastic bottles or suction cups act as lenses, which may cause fires.

Safety measures for starting

When you are on / off the machine, support your weight by three points of safety posture.

Please do not jump on or adjust the machine. Do not try to go up and down the moving machine.

When the upper and lower space is opened, please first open the door to the lock-in position, and check and confirm that the door cannot move.



For machine climbing up / down pedals and supporting armrest, support your weight with three safety posture (hands and feet).

Do not use the control rod as a pull hand.

Any unauthorized personnel should leave the area before starting the machine.

By checking the following items, it is sure that it can start safely before starting the machine.

Round the machine for a week, give warning to the maintenance machine personnel and the walking personnel near the machine. After that, no machine can start the machine.

Check whether there is "caution" sign or similar sign on the driver's space, control or starting switch. If there is, please do not start the engine or touch any joystick.

Sound the horn and warn the people around the machine.

Sit on the driver's seat, start the engine

Adjust the seat to locked position.

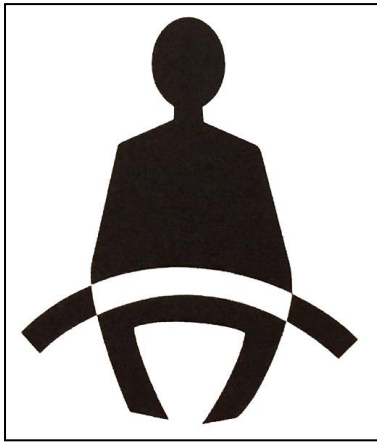

Fasten Safety Belt.

Check whether the parking device is open, and whether all the control rods and pedals are in the middle position.

There is no one near the machine.

The machine can only be started and operated from the driver's seat.

Do not attempt to start the engine by shorting the terminal of the starter.

Use of cross connection cable to start

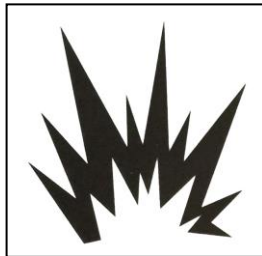

Starting with jumper cable can only be carried out in a recommended way. Improper use of jumper cable will cause battery explosion or unexpected machine action.

Starting engine

After starting the engine, do the following operation and check in the place where there are no personnel or fault. If any failure occurs, shut down according to program and report failure.

Preheat the engine and hydraulic oil.

Check whether the instruments and alarm devices are working normally.

Check if there is any noise.

Test the engine speed control.

Operate the control to ensure that they work normally.

For cold climates

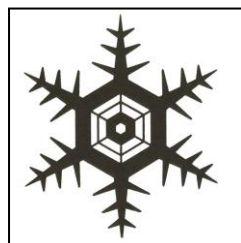

Be careful on frozen ground, pedal and handle. It's slippery.

Do not touch the metal part of the machine with bare hands under severe cold weather. The skin will freeze to the metal and cause serious injury.

Do not use ether or starting fluid on the engine. Starting fluid/Ether can cause explosion and serious injury or death.

Preheat the engine and hydraulic oil. If the lever is not preheated, the machine will not respond or move quickly or appropriately, resulting in an accident.

Signage

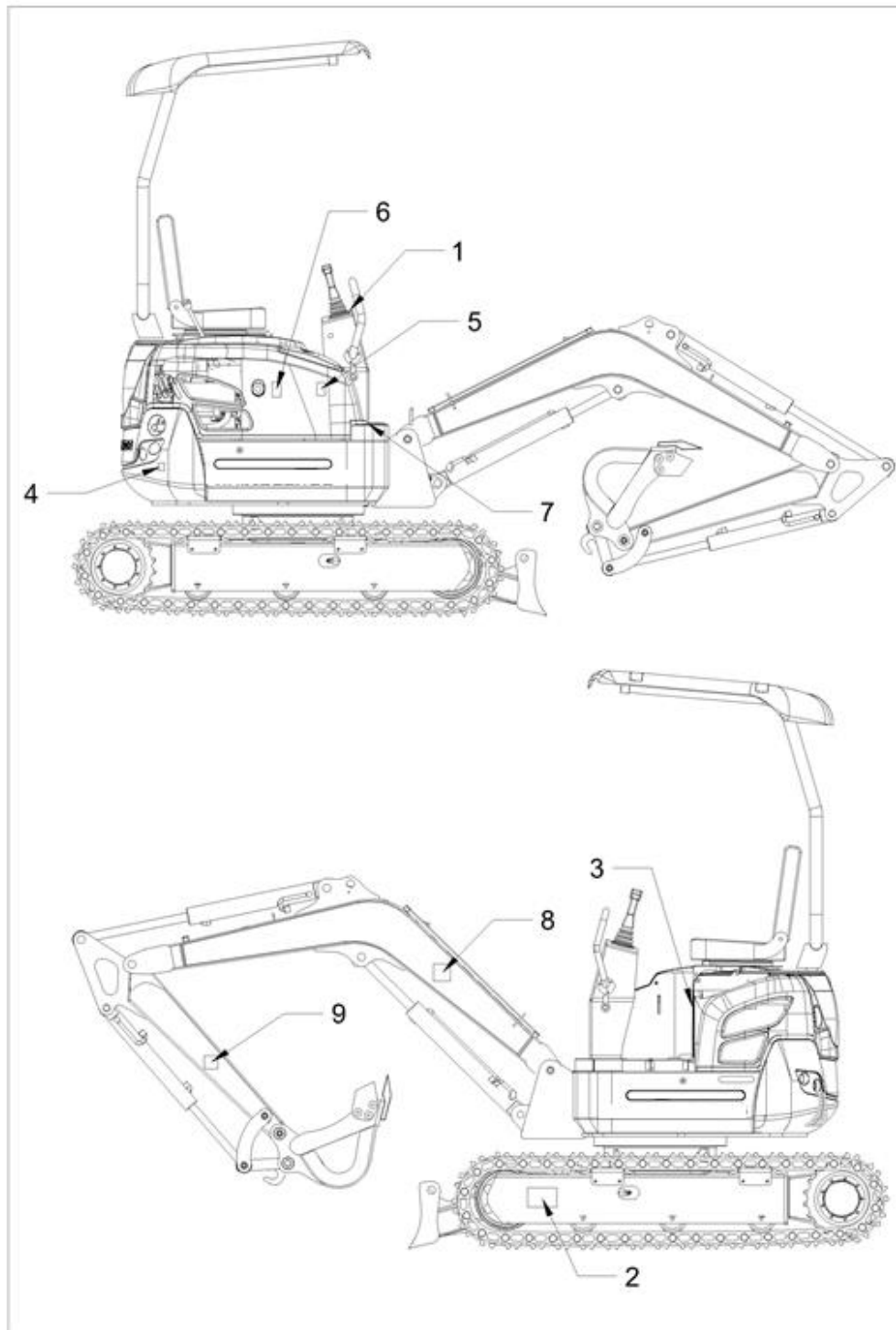

Operating Instructions

⚠WARNING

- In order to prevent accidents of personal injury or death due to wrong operation, please confirm the operation state and the operation mode of the machine when operating the machine. When confirming the running state of the machine, please pay attention to the peripheral parts and operate slowly.
 - In order to carry out the loading and unloading operation on the transport vehicle safely, we must strictly observe the following items.
 - We must make the brakes of the transporter work and the blocks on the tires should be added.
 - The loading and unloading boards must be steel plates with a very long length, width, strength and smooth surface.
 - In order to make the transport vehicle consistent with the vehicle center, the loading and unloading board must be fixed well.
 - Under the loading and unloading board, the padding or prop must be added.
 - The angle of the loading and unloading plate is less than 15 degrees.
 - Loading and unloading operations in a flat and hard place.
 - In order to prevent serious injury or death accident, following the mobile machine or operation machine, please observe the following items:
 - Please sound the horn and tell the people around.
 - Please confirm whether there is no one in the upper, surrounding or rotating area of the machine.
 - To ensure the vision of the forward direction, rotate the upper part if necessary.
 - Please set up the watchman at a place where the vision is bad
 - For these matters, please follow the traffic warning and install mirrors.
 - It is necessary to turn the safety locking lever to the locking position before standing from the driver's seat.
 - If the levers are touched carelessly, the machine will act suddenly, which may cause a major personal accident.
 - Also check the machine control mode and all labels should be consistent. If different, before changing the machine, change related labels to match the machine control mode.
 - Non-standard operation may cause death or injury.
 - Precautions for adjusting the tightness of the crawler.
 - Operation warning, loading warning, mobile and operational warning, front window warning, attention to high voltage line, reading instructions, oil lock, height and other warning signs.
4. Stay away from the gyration are
- The rotary machine strictly prohibited within the region.
 - "Do not damage or remove the logo from the machine.
 - Fuel identification.

- When refueling to turn off the engine, the fuel filler should be far away from all the fire.
- Notice of fuel oil.

⚠WARNING

- Fuel tank: No smoking is allowed when fuel or fuel system is added to the machine. No fuel is allowed near the flame or spark zone, and the engine must be stopped before refueling. Add fuel to the outdoors.
- The battery will produce explosive gas, and it should keep away from fire and open flames. When battery is used, it should ensure good ventilation.
- Metal objects such as tools or inflammable products should not be placed with batteries. Waste batteries should be disposed according to local environmental regulations.
- The electrolyte in the battery is highly corrosive, which can corrode the skin and clothing. If splashing into the eye, it will lead to sulfuric acid splashing on the body.
- Rinse the skin with water.
- Use soda or lime to neutralize the acidity.
- Rinse your eyes for 10-15 minutes and treat immediately.
- The notice of the use of the battery

The battery will produce explosive gas, and it should keep away from fire and open flames. When battery is used, it should ensure good ventilation.

Metal objects such as tools or inflammable products should not be placed with batteries. Waste batteries should be disposed according to local environmental regulations.

The electrolyte in the battery is highly corrosive, which can corrode the skin and clothing. If splashing into the eye, it will lead to sulfuric acid splashing on the body.

1. Rinse the skin with water.

2. Use soda or lime to neutralize the acidity.

3. Rinse your eyes for 10-15 minutes and treat immediately.

- Strictly prohibited within the operating range This sign is located on both sides of the arm
- Away from the mining range
- The pressure in the hydraulic cylinder of the track tightener is very high. It must be adjusted or disassembled according to the operator manual. The wrong operation can cause personal injury.

⚠WARNING

- Hydraulic oil tank:
Before opening the cover, the engine should be stopped, and the lid of the fuel tank can be slowly discharged, so as to release the pressure of the hydraulic tank and prevent the scalding of the hot oil.
- Away from the engine belt.
- Don't open the hood when the engine is running.

- Don't touch the exhaust pipe to prevent burns.
- In order to prevent injury, we must strictly observe the following items when we go up and down the vehicle.
- Going up and down, you should face the Excavator.
- More than three hands and feet are often used to grasp the armrest and pedals, so that the body can be supported.
- Do not catch the rod or the rod and get off.
- Do not move up and down in the movement.
- Don't jump up and down.
- The machine should be away from the high-voltage power line. If it is near the power line, the machine and the ground may be struck by electricity, causing casualties.
- Keep clear of dangerous area

1. Operating device operation

Operation bar (handle) (ISO) operation description

▲ Warning
Check it around before turning.

▲WARNING

- When you start working, slowly move the handle check the swing action and the front working device.
- The handle structure of this equipment is up to the ISO standard, and the parts of valves and hoses should not be changed to maintain standard settings.

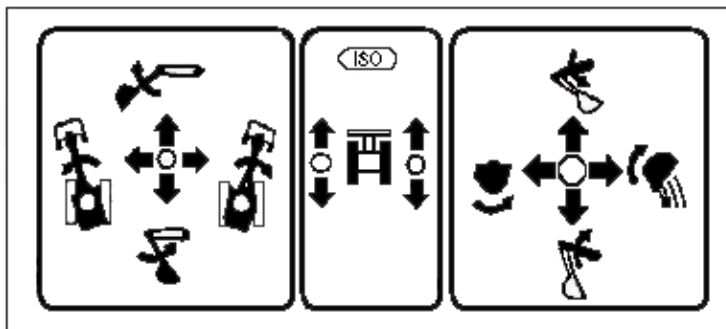

On the right side of the driving operation, with an operating sign

Push the joystick / pedal forward or backward when going straight.

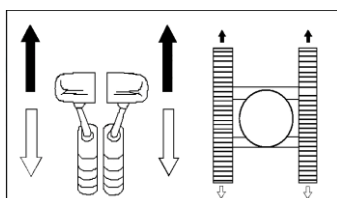

⚠WARNING

- When the moving distance exceeds 2km, the trailer should be towed. When moving within 2km, it should be carried out intermittently: walking for 10 minutes and resting for 5 minutes, otherwise it will cause serious damage to the excavated parts.

When manipulating a crawler forward or backward, the machine revolves by taking the stationary track as a rotary shaft.

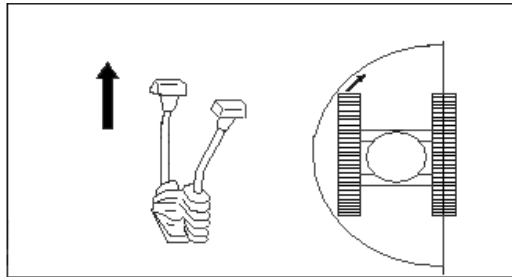

When a track turns forward and another turns back, the machine will revolve around the center point.

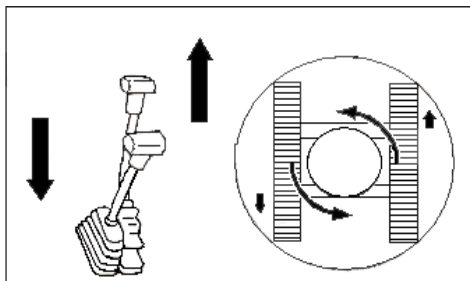

Stop walking - when the joystick returns to the central position, the excavator automatically stops and parks.

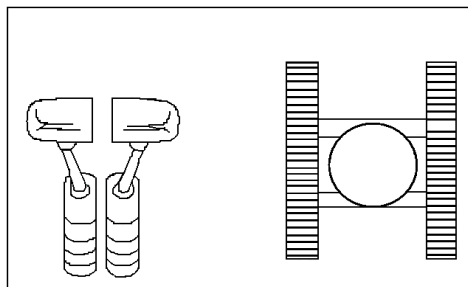

The relation between the movements of the boom, bucket and bucket and the moving direction of the rod is as follows:

Left handle

1. Stick out

2. Pole recovery

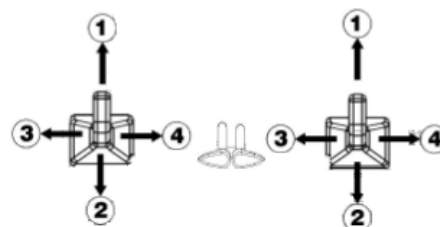

3. Gyration

4. Gyration

⚠ WARNING

- Slewing brake is realized by spring and relieving hydraulic pressure. When the handle is in the middle position or the engine stops, the excavator can turn the brake.

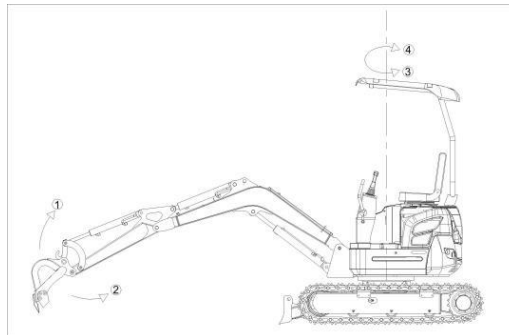

⚠ WARNING

- The following phenomenon is not a mechanical failure, but a normal phenomenon of the excavator.

There may be a pause in the action of the bucket.

Because of self weight, the movement of bucket can be accelerated, which may cause insufficient oil supply.

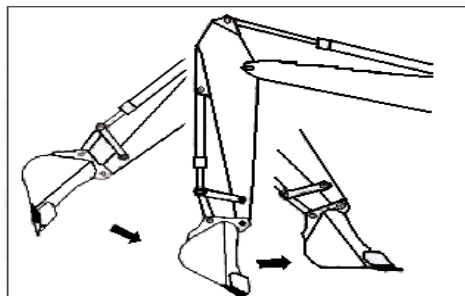

Right handle:

- ⑤ Brachial descent
- ⑥ The arm up
- ⑦ The bucket digging

⑧ The bucket dump

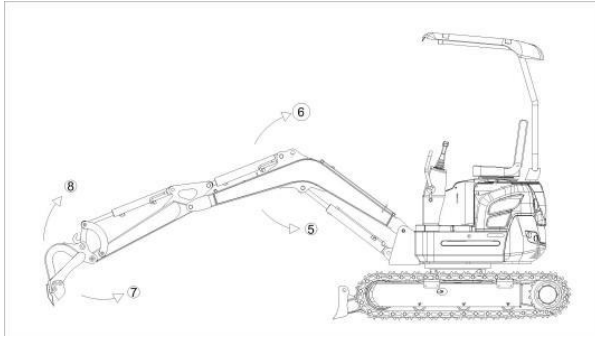

⚠WARNING

- Note: even if a shutdown, the operation handle can still reduce the front device to the ground, set the safety rod in the "unlocking" position, and turn the key switch to the "shut" position.

Precautions for operation

Ensure good sight

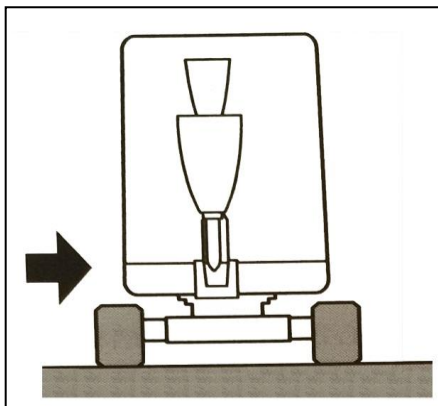

When working in dark places, turn on the work lights and headlights of the machine, and install additional lighting if necessary.

Because bad weather (fog, snow, rain or haze) leads to poor sight, we should stop operating the machine until the sight is better.

⚠WARNING

- Do not carry people on the machine

When a machine walks or operates, no one is allowed to ride on any part of the machine at any time.



⚠WARNING

- Check whether the work area is safe and reliable before operation.

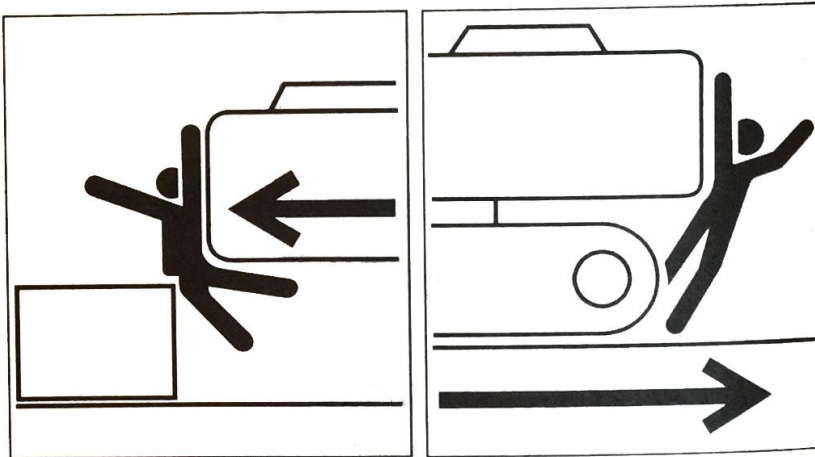

Confirm the performance limit of the machine.

In the road shoulder, narrow place or line of sight obstructed, use signalling.

Do not allow anyone to enter the turning radius and path of the machine.

Express the intention that you want to move by honking the horn.

There is a blind spot in the rear of the machine. Please check the safety of the rear area before you walk back and make sure that the rear is unmanned.

⚠WARNING

- Check the position of the frame (excavator) before walking

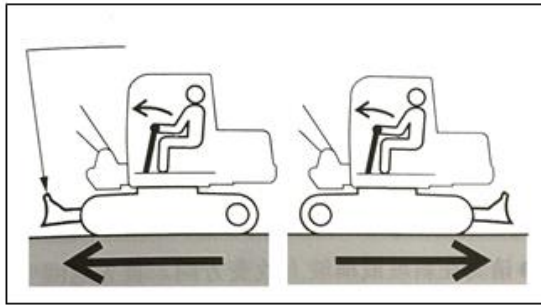

Shovel

Before operating the walking joystick / pedal, make sure that the shovel is in front of the driver's seat. Remember, when the shovel is located behind the driver's seat, the operating direction of the walking joystick / pedal must be opposite to the shovel in front of the driver's seat.

Safe walking

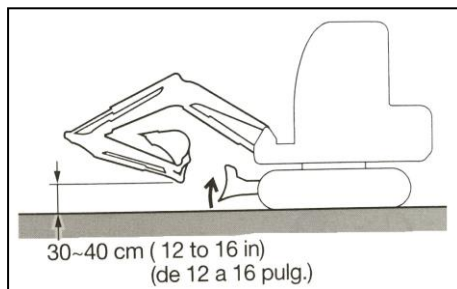

When walking, the bulldozer is raised, and the bucket operation device is lifted according to the above picture, and the bucket is raised to 11.81 inches to 15.75 inches above the ground.

⚠WARNING

- Do not turn around when you walk. If you must operate the bucket operation device when walking, the speed should be slow enough, so that you can fully control at any time.

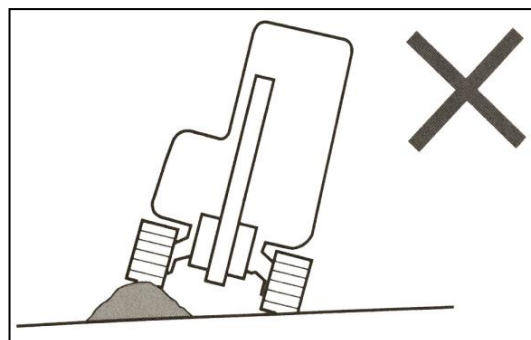

Try to avoid crossing obstacles. If we have to do this, we should keep the bucket operation device close to the ground and walk slowly. Do not exceed the obstacle that will tilt the machine to 10 degree or greater angle.

On the uneven road, keep walking at low speed, avoid suddenly starting, stopping or changing direction. Otherwise, the working device may contact with the ground, causing the machine to lose balance and damage, or to break the structure in the surrounding area.

Matters of attention walking on a slope

When walking on slopes or ramps, be careful not to overturn or slide down.

⚠WARNING

- Do not walk on the steep slope where the machine can not maintain its stability (the maximum gradient is 30 degree; the lateral inclination is 10 degrees).
- Please note that, based on different working conditions, the actual machine stability will be lower than the above-given value.

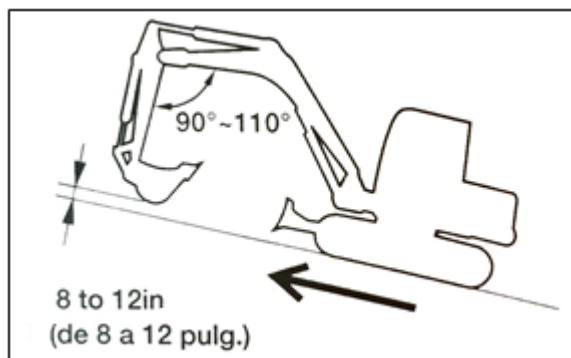
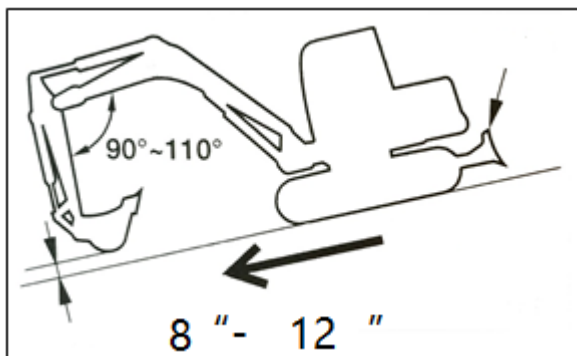

When climbing the mountain, keep the driver's seat on the hillside. When you go down the mountain, keeps the driver's seat facing the downhill direction. In these two cases, we must pay attention to the ground in front of the machine when we walk.

When walking on the slope, the bucket will be reduced to 8 in to 12 in above the ground. When climbing the steep slope, extend the bucket operation device to the front. In case of emergency, the bucket is lowered to the ground and the machine is turned off.

When driving on slopes or ramps, drive slowly at low speed. Lower the ramp, reduce engine speed.

⚠WARNING

- Please do not reverse the downhill.
- Do not change direction on a slope or a cross slope. First, return to the flat surface, then select another path.
- Be careful to operate a machine on snow or ice

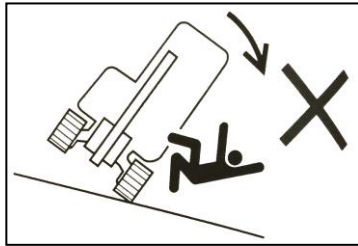

When walking on a gentle slope covered with grass or dead leaves or on wet metal plates or frozen ground, the machine may slip sideways. Make sure that the machine does not stop on the slope.

If the machine is extinguishing on the slope, please return the joysticks to the middle position, then restart the engine.

When walking on snow or ice ground, we should drive at low speed to avoid starting, stopping or changing direction.

In snowy areas, objects placed on the shoulders and roadsides are buried in snow and can not be seen. There is also the danger of overturning or bumping objects, so always operate with care.

If the machine enters thick snow, there will be danger of overturning or burying into the snow. Be careful driving, do not exceed the road shoulder or be trapped in the snow.

⚠WARNING

- Do not move the bucket to the top of the head

For the frozen soil surface, when the temperature rises, the ground will soften, which may cause the machine to overturn and cause the operator to be trapped in the machine.

When parking on unstable ground, down the bucket.



If the bucket is moved to the top of the staff's head, there will be a danger of the scatter of the load or the sudden fall of the bucket.

The safety of the driver should be ensured when loading

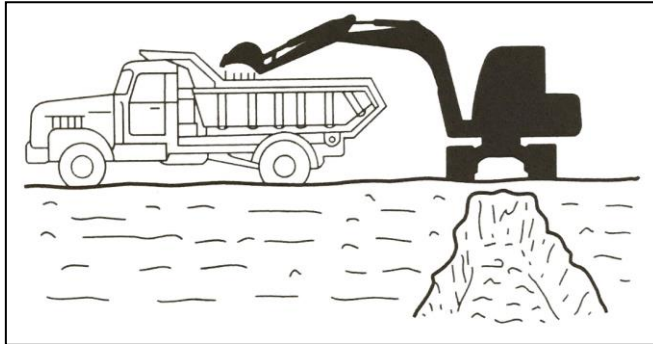

⚠WARNING

- Do not load the driver before reaching the safe place.
- Do not swing or park the bucket on the unit.
- Load from the back of the truck.
- Keep safe distance from overhead high voltage cable

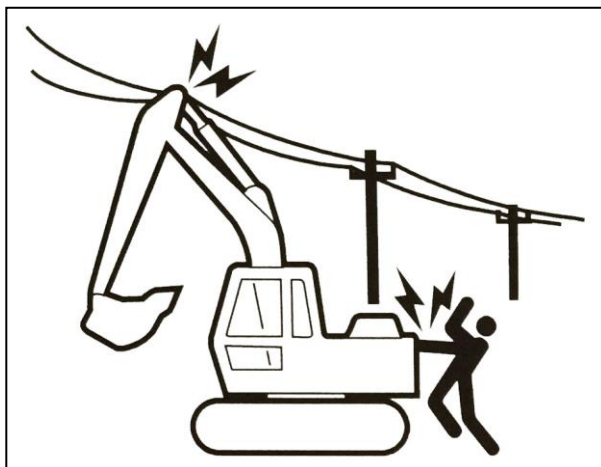

⚠WARNING

- When it is close to the cliff or shoulder work, it is easier to escape when problems arise. In operation, the crawler is at the right angle with the cliff or the shoulder, and the shovel is placed in front of it.
- Do not enter the soft ground area. This may cause the machine to tilt due to its weight and cause it to overturn or fall into the ground.

- Do not approach unstable ground (cliff, shoulder, deep trench). If the ground collapses due to the weight or vibration of the machine, it may be dangerous for the machine to fall or overturn.
- No part or loading material of the machine should be near the high-voltage cable unless all the safety measures required by the local and national institutions have been taken. If the staff is close to the spark that is being discharged, or the machine adjacent to or touching the power supply, there will be danger of electric shock and death.
- Always keep the safe distance between the machine and the high-voltage cable.
- Before proceeding with operation, please check with local electric power Company about safe operation procedure.
- All cables are regarded as high-voltage cables, even if they are known or believed to have been cut off, and the cables are obviously grounded, they are also treated as live cables.
- If the machine is too close to the high-voltage wire, use the signaling officer to issue a warning.
- Note that all personnel in the operation area must not be close to the machine or the materials loaded.
- Pay special attention to the high pressure cables buried underground.
- Pay close attention to the conditions of dangerous work
- No digging in the high embankment bottom. This may cause ground collapse, so it's dangerous.
- Do not operate where it is in danger of falling rocks.
- Keep the safe distance between machine and mining field edge. Do not dig the ground in front of the machine. Please remember that the soil is not strong after heavy rain or blasting.
- The ground is not strong at the top of the embankment and around the ditch.
- Do not disassemble the top of the head while doing the dismantling operation. There is a danger of breakage, falling or building collapsing, resulting in serious injury or damage.
- Do not do the dismantling operation under the machine. Because the ground becomes unstable, there may be danger of machine falling.
- When working at or from the top of a building or other structure, check the strength and structure before operation. If a building or building collapses, it will cause serious injury or damage.
- Do not use the impact force of the bucket operation device to do the breaking operation. There is a risk of serious injury due to splashed material debris and damaged bucket operation device.

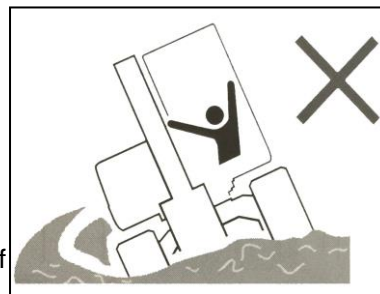
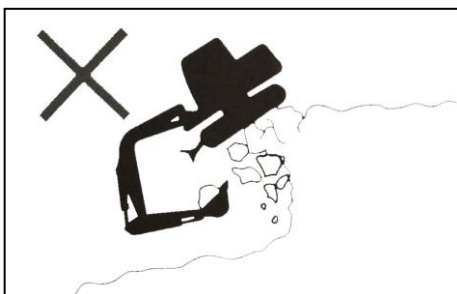
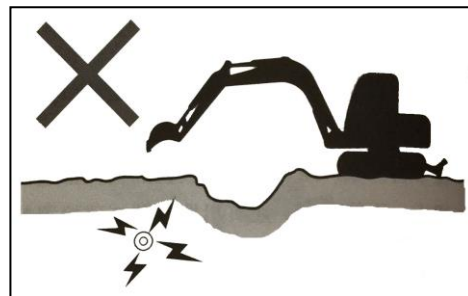
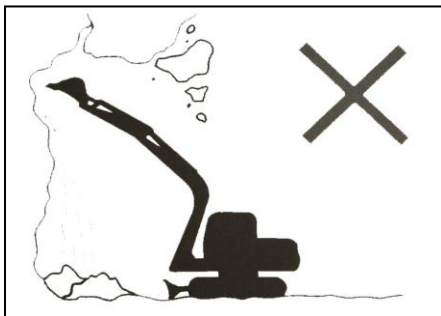

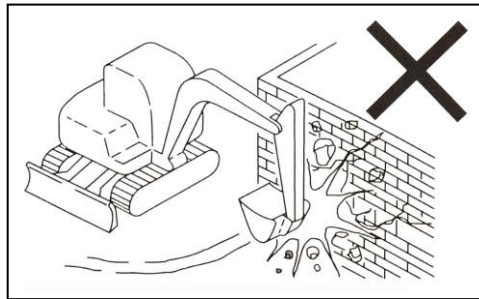
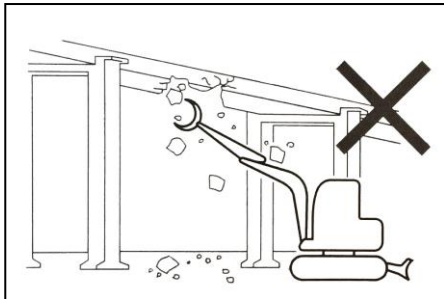
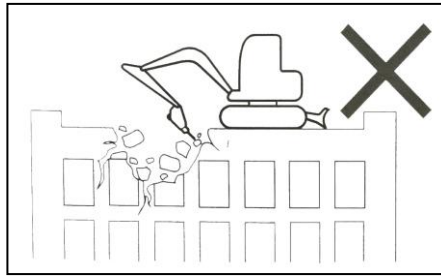
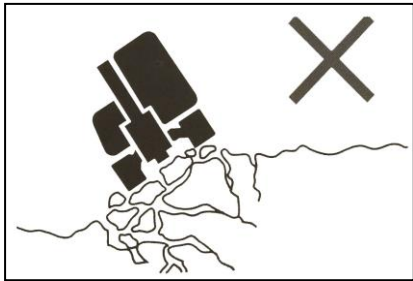

It's dangerous to operate on the slope

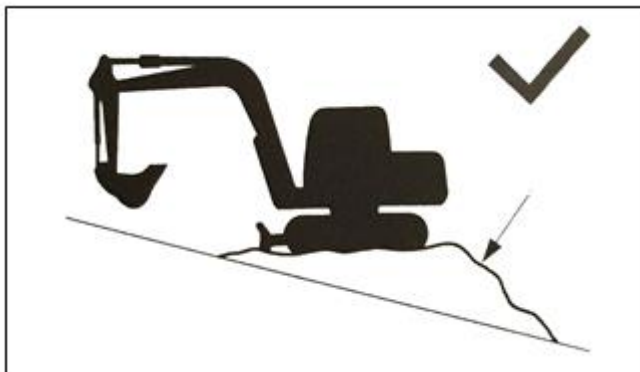

When operating on ramps or ramps, rotating or operating devices may cause instability and overturning of machines. It should be avoided to operate on the slope as far as possible.

Leveling the operation area.

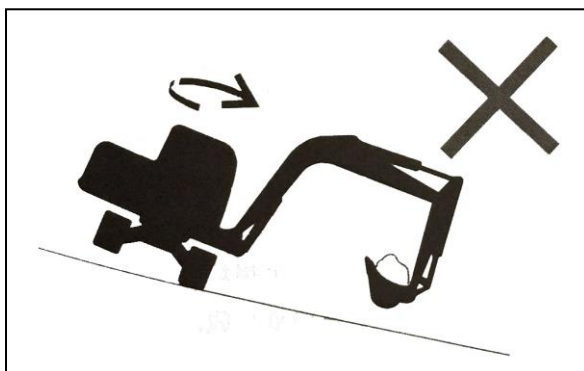

When the bucket is loaded with material, avoid turning to the down hill direction. This will reduce the machine's stability and cause capsizing.

When the bucket has heavy load, do not turn side to side (swing).

It is easier to overturn the machine in the transverse direction than the longitudinal.

⚠WARNING

- Do not turn around when the bucket operation device has heavy load at the end. Especially do not turn side to side on the slope.

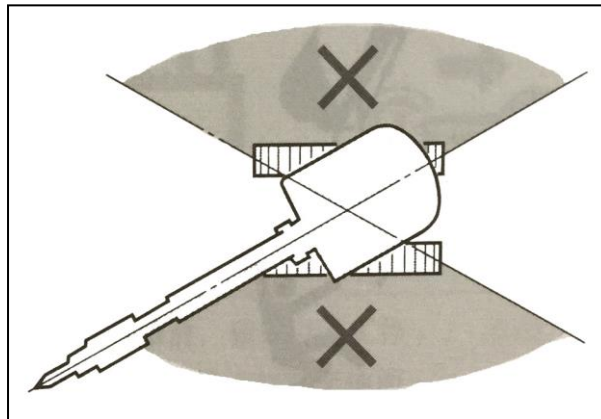

When the machine is equipped with a broken hammer, a grinder or a long rod, the attachments end are heavier than those equipped with standard bucket. To this end the heavy machine, do not allow the bucket rod (boom) toward the down direction or toward the side of the operation of digging machine.

⚠WARNING

- Please pay attention to the top object

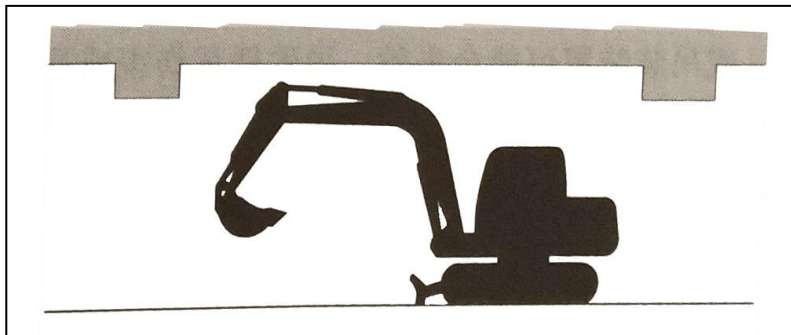

When operating under the bridge, tunnel, cable or indoor, pay attention to the boom or bucket do not hit the top object.

The excavator is not designed for hoisting

This machine is specially designed for mining. Therefore, it has no safety device for crane operation. If excavators are used for hoisting operations, special care must be taken.

⚠WARNING

- Do not overload in hoisting. Overloading can cause machine overturning, causing serious injury or death
- Do not allow anyone to stand on or below the lifting object or near the operation area.



⚠WARNING

- During traction, improper operation, incorrect cable or improper examination will lead to serious injury or death.
- If a cable breaks or takes off a meeting, it is dangerous. A wire rope is used to match the traction force.
- Do not use, or even damage the cable twist kink.
- Do not suddenly increase the load on the cable.
- When handling the cable, please put on the safety gloves.
- Make sure that there is an operator on the excavator.
- Do not make traction on the slope.
- Please do not approach the cable when any traction is carried out.

All rated lifting capabilities are based on stable and flat ground using this machine. For safety lifting operations, we hope that users will have appropriate allowance for specific working conditions. They include loose or uneven ground, non horizontal state, lateral load, dynamic or sudden load, dangerous environment and personnel experience. Operators and other personnel are very familiar

with the operation manual before machine operation. They must strictly abide by the safety operation rules of the equipment at any time.

If the chain or hoisting device is not properly connected, the bucket connecting rod or hoisting device may fail, causing serious injury or death.

When the machine is used as a crane, do not attempt to pull out the stump from the ground. In this way, the load safety on the machine is unknown.

This machine is not equipped with protective devices to protect operators from flying objects. Do not use this machine when the operator may be hit by a flying object.

Precautions for traction

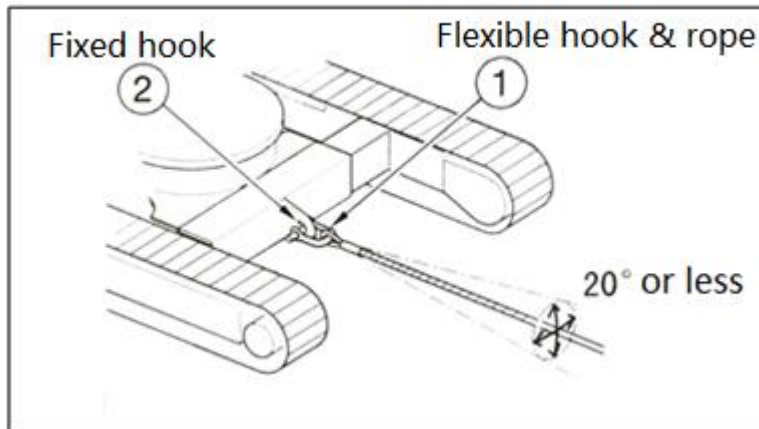

Operating procedure

Prohibited operations

⚠WARNING

- Do not operate on the bedrock (hard or soft).
- Do not turn around when you walk. If you must operate the bucket operation device when walking, the speed should be slow enough, so that you can fully control at any time.
- Do not use rotary force to disassemble or flatten operation.

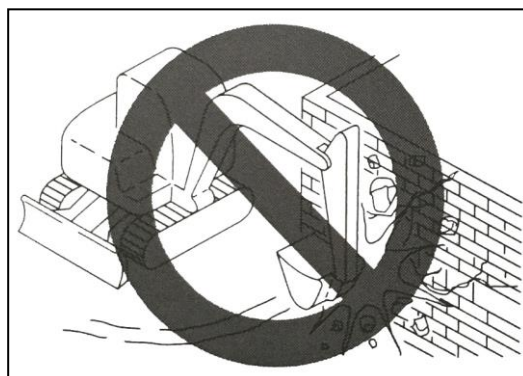

⚠WARNING

- Do not use rotary force to disassemble walls or leveling floors. In addition, do not dig the bucket teeth into the ground. This will damage the bucket operation device.
- Do not dig when you walk

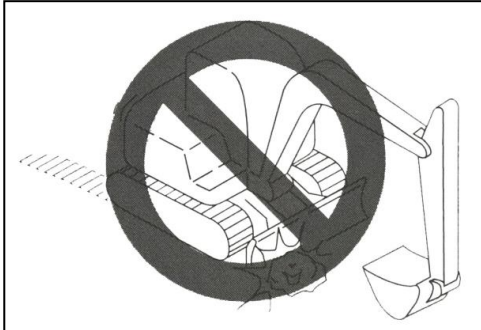

⚠WARNING

- Do not dig the bucket into the ground and use the walking force to excavate.
- The use of hydraulic cylinders should be slow

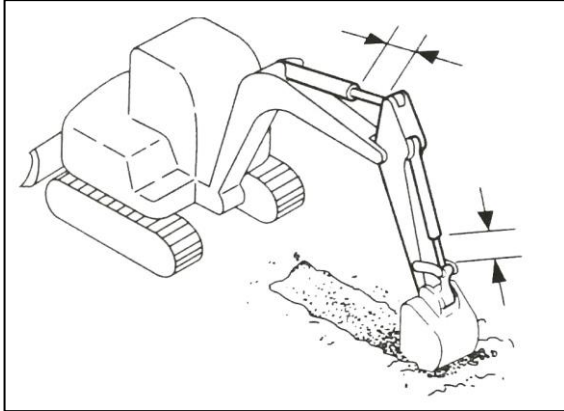

⚠WARNING

- Do not extend the hydraulic cylinder to the head. During the operation, you should leave some leeway.

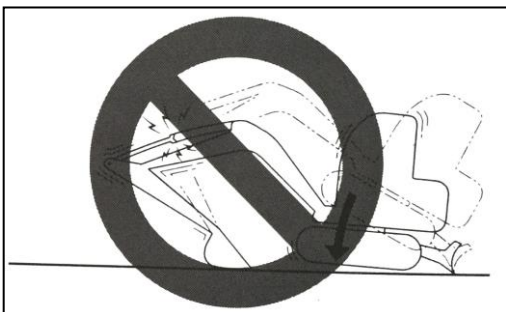

When the body is down and the bucket cylinder is fully extended, do not use the bucket operation device to support the body. Doing this will concentrate the load on the bucket cylinder and damage the bucket cylinder.

⚠WARNING

- Do not use the bucket to push or dig through the heavy bucket.

This will shorten the service life of the bucket operation device. Use liquid pressure to excavate.

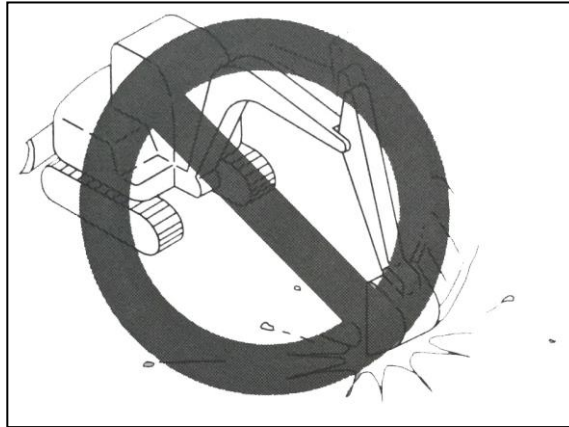

⚠WARNING

- Do not use the sinking force of the machine to perform the operation

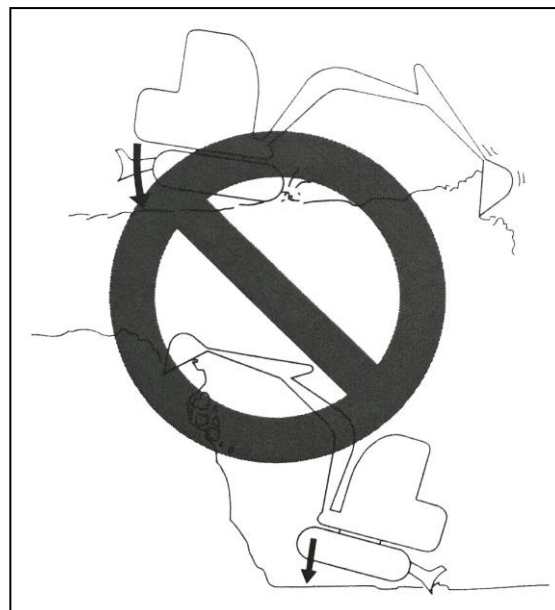

Applying additional tension to the machine will shorten its service life. When digging, the hydraulic pressure of the oil cylinder should be shallow, and the stroke must be large.

Excavation of bedrock

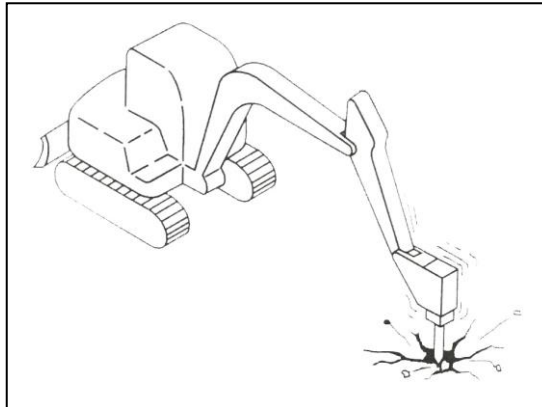

For hard bedrock. Before digging, it is advisable to use broken hammer to break up rock into small pieces. In this way, the damage to the machine can be prevented, so it is more economical.

Attention to the impact of the shovel

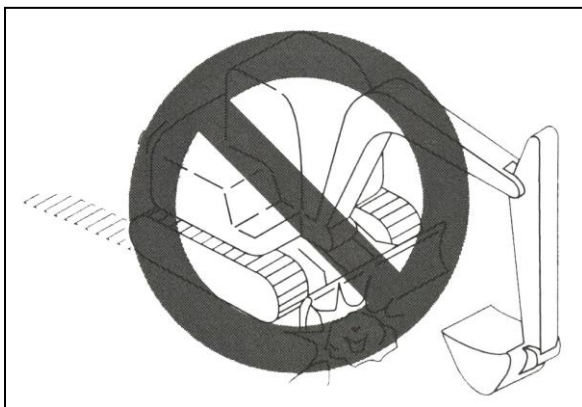

It will damage the excavator and earth shovel oil cylinder by pushing the soil shovel to rock.

Take care of the bucket work device

When lifting the bucket operation device, be careful not to make the bucket hit the excavator shovel.

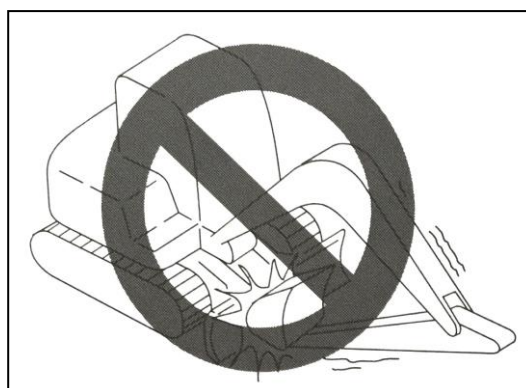

⚠WARNING

- Do not use the shovel as a support

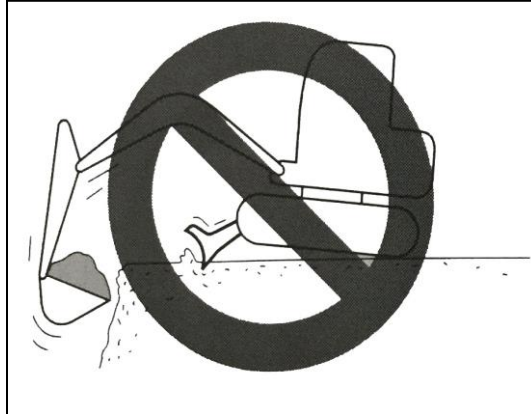

⚠WARNING

- Pay attention to the shovel in excavation



In deep excavation, such as the excavator shovel in front, be careful not to cause the boom and bucket to hit the excavator shovel.

When operating, try to make the shovel in the rear.

Be careful to use the earth shovel down to dig down

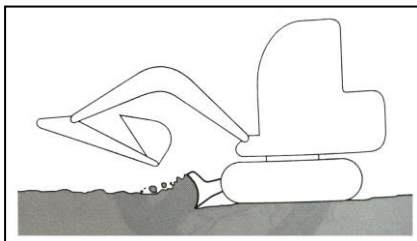

The design of this shovel is used for simple drawing operation. Do not use a earth shovel to dig down. This may damage the shovel and the lower frame.

Operational precautions

Precautions for walking

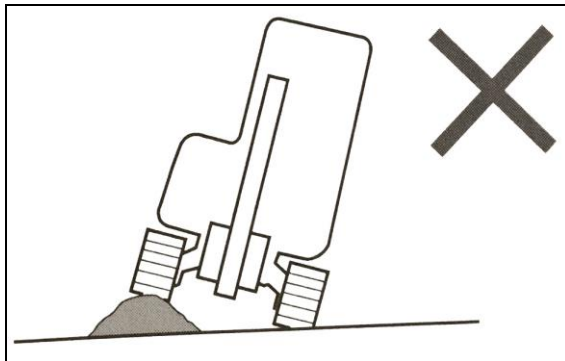

When walking on obstacles (rocks, stump, etc.), it may exert great loads on the body, and may cause damage to them, so as to avoid crossing obstacles. If we have to do this, we should move the bucket operation device near the ground and walk at low speed, so that the center of the track can climb obstacles.

Attention to high speed walking

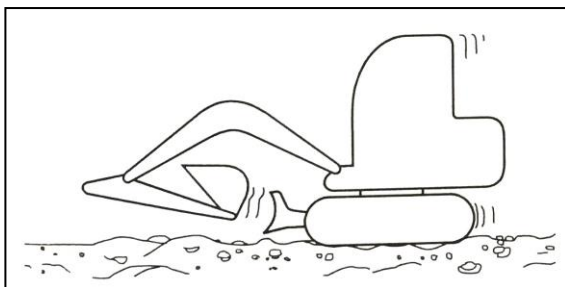

On the uneven road, keep walking at low speed, avoid suddenly starting, stopping or changing direction.

The shovel should be in front of the high speed walk.

Precautions for the use of this machine in water

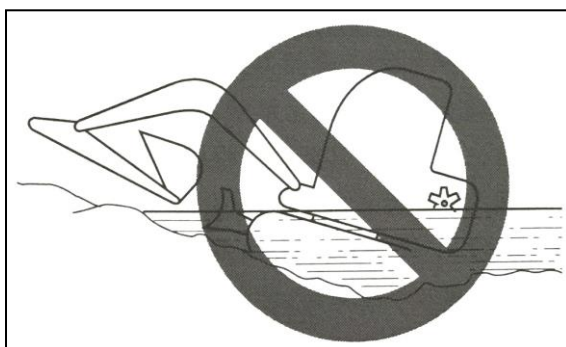

If the rear part of the machine, as shown above, is immersed in the water, the radiator fan will be rotated in the water, resulting in the damage to the fan and the rear part of the machine must not be immersed in the water.

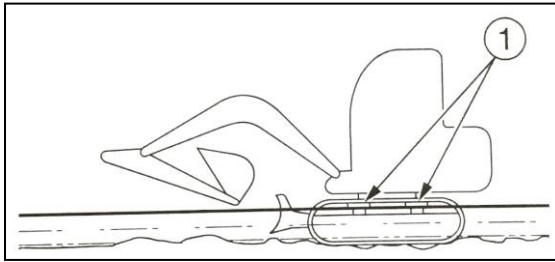

Allow water depth

Only when the water does not exceed the track slip, can the machine be used in the water.

For those that are used for long time in the water, enough oil should be filled until the old oil is squeezed out.

Do not immerse the rotating bearing or main body in water or sand. If it has been submerged, please contact Nortrac service agent for inspection.

Out of the mud

If the machine falls into the mud, please follow the following steps.

If an excavator falls into the mud

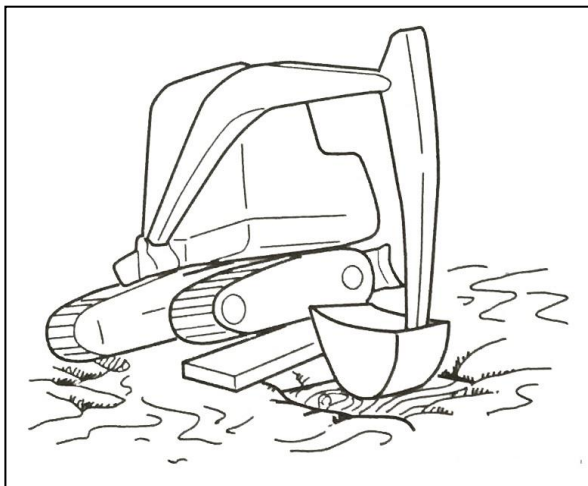

1. Put the bucket into the excavator side in the mud.
2. The angle of bucket and boom is set from 90 degrees to 110°.
3. Press the bottom of bucket instead of bucket teeth on the ground.
4. Put a piece of wood or similar object under the raised track.
5. Improve the bucket and slowly drive the machine out of the mud.

If two tracks fall into the mud



1. Perform the above steps to two tracks from 1 to 4.
2. In front of the machine, the bucket is dug into the ground.
3. When walking forward, pull the rod and move the machine slowly out.

Excavation

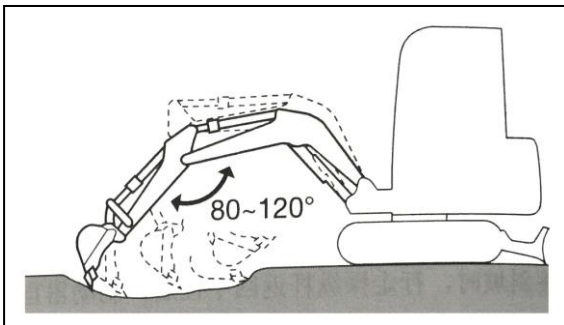

1. the earth shovel is to the opposite side of the excavating area.
2. digging with bucket and bucket, when digging, it should be shallow and long. The digging force is the largest when the angle between the boom and the boom is between 80 and 120 degrees. It is appropriate to use this angle for effective mining.

Dig trenches

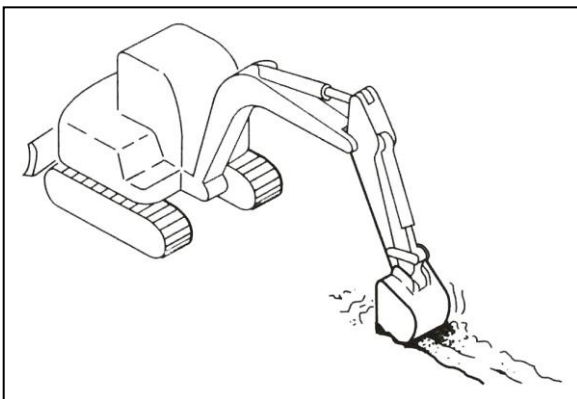

A bucket suitable for digging ditches is installed to adjust the track to parallel to the ditch to be excavated, so as to improve efficiency.

Leveling

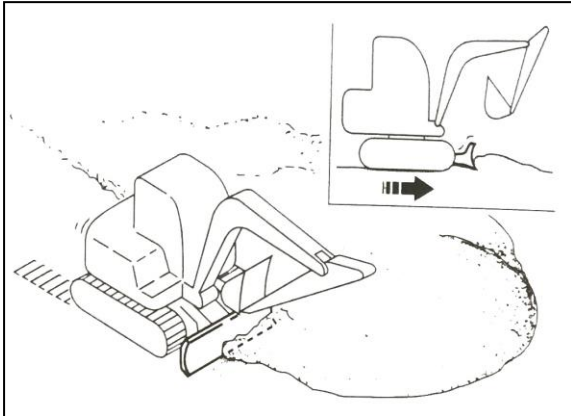

1. The bucket work device is close to the collective.
2. Slowly push the soil away from the side of the pile.
3. When the pile is low, the soil is pushed from the top. If the load is too heavy for the body, it will increase or decrease the adjustment of the excavator shovel.

Rubber tracks

Because rubber is used, rubber track has inherent weakness, that is, lack of strength. Please abide by the following prohibitions and precautions, so as to prevent track damage or fall off.

Injunction

Do not walk or operate the machine at the following locations:

Walking and turning on rubble, very rough and hard rock, steel beam, scrap iron, or near the edge of the steel plate will damage the rubber track.



Walking on the river bed or with large amount of pebble can cause the stone to be stuck in the track and damage the track, or cause the track to fall off.

Please do not use this machine at the seaside. Salt may corrode the steel core.

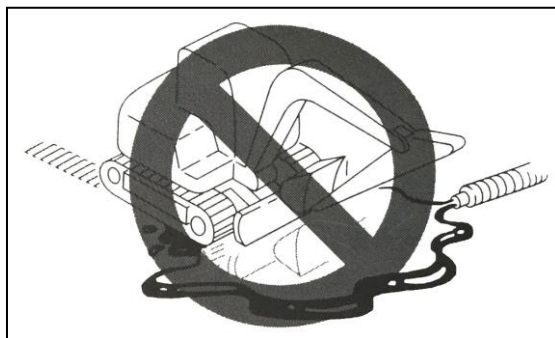

No fuel, lubricating oil, salt or chemical solvent should be attached to the crawler. These substances may corrode the rubber track core welding, and lead to rust or spalling. If any of these substances stick to the track, they should be cleaned immediately.



If the machine walks on the irregular surface, such as the newly paved asphalt pavement, exposed to the bonfire or walking on the hot iron plate under the sun, it will cause unconventional wear or damage to the handle.

Do not move the ground where rubber tracks may slip. Otherwise, it may accelerate the handle wear.

Matters needing attention

Please observe the following points when you operate the machine.



Do not use the bucket operation device to turn the frame down when it rises in front of the fuselage. Otherwise, it will twist the track at a single point when the load is concentrated in the tracks, resulting in the rapid damage of the track.

Whenever possible, avoid changing the route or turning on the concrete surface as far as possible.

This will wear or damage the rubber tracks.

Avoid falling, resulting in strong impact on rubber tracks.

Salt, potassium chloride, ammonium sulfate, potassium sulfate and lime superphosphate will damage the track. If any of these substances are covered with excavator, they should be cleaned immediately.

Do not rub the sides of the rubber track against the concrete or the wall.

Don't let the bucket blow on the rubber track to cause track damage.

In winter, we should be very careful on the surface of snow or ice, because the track is easy to slip under such conditions.

Please use rubber track between -13°F and 131°F .

For long-term storage of rubber track (three months or longer), please store it indoors without exposure to direct sunlight or rain.

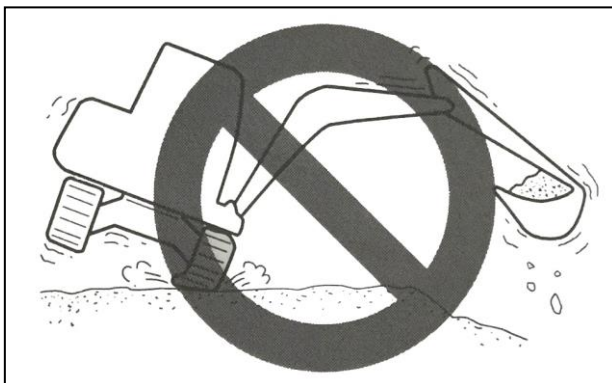

Because the whole handle is made of rubber, rubber track is not as stable as rubber track. Be careful when turning and swinging horizontally.

Prevent rubber excavator tracks from falling off

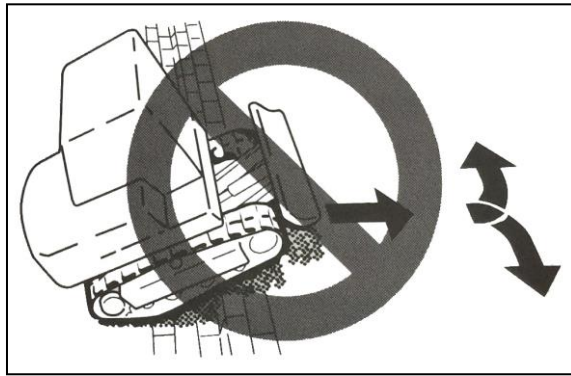

Observe the following precautions to prevent the excavator tracks from falling off.

Always maintain the proper strength of the crawler.

When a vehicle has to cross a large step such as a cobblestone or rock, (20 centimeters or deeper), climb up the steps at a right angle, and do not change the route on the steps.



When reversing and climbing, do not change direction at the beginning of the slope.



Avoid placing a caterpillar on a slope or a prominent part, while another track is placed on a flat surface (the machine inclines at 10 degrees or more). Please walk the two tracks on a flat surface.

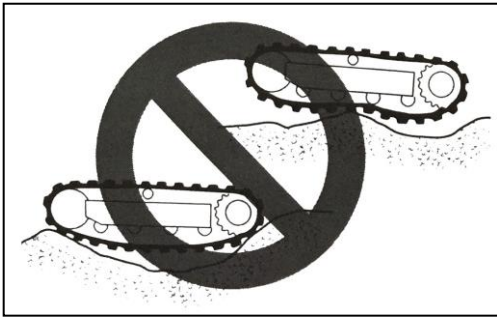

Do not change direction when the track is relaxed as shown in the picture.

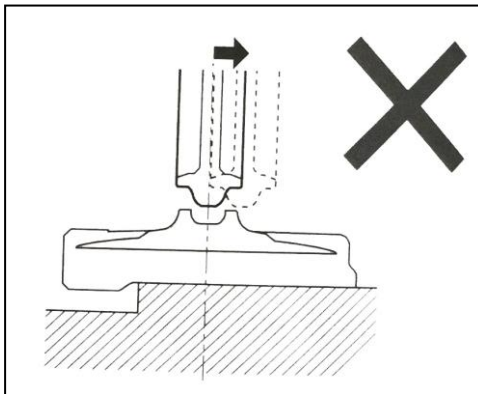

In this case, if the machine moves backward, the rubber track will fall off.

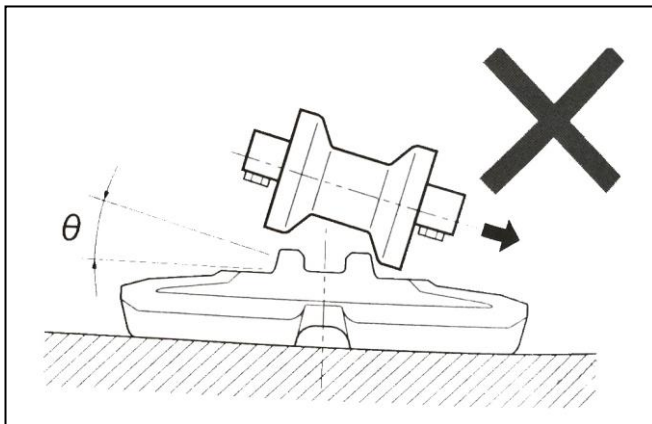

In this case, if the machine rotates, the rubber track will fall off.

Hydraulic breaking hammer

Refer to the manual of hydraulic breaking hammer provided separately for the operation of breaking hammer.

When installing options such as crushing hammer, tilting bucket or grab bucket, please ensure that it is suitable for the machine model being used.

When you choose attachment, please contact your sales or service agent.

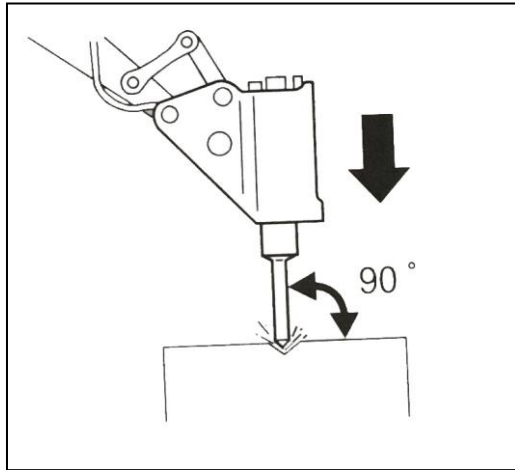

The hammer head is used vertically to the working face for breaking operation.

When broken, the hammerhead should be directed at the object to be broken, so as to avoid hitting the air.

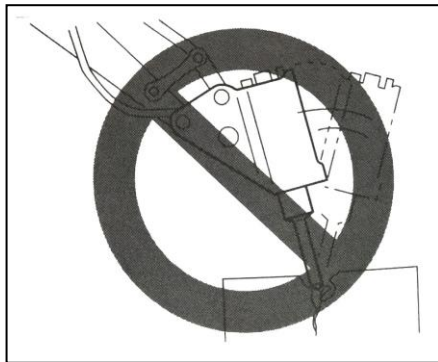

Don't pry it with a hammer, and do not pry when it is broken.

Do not move the hammer when it is broken.

On the same surface, do not continue to impact for more than 30 seconds.

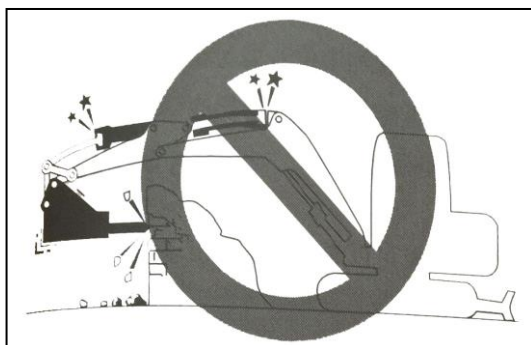

Cylinder full extension or shrink (stroke end point) were not broken. Keep at least 1.97in gap.

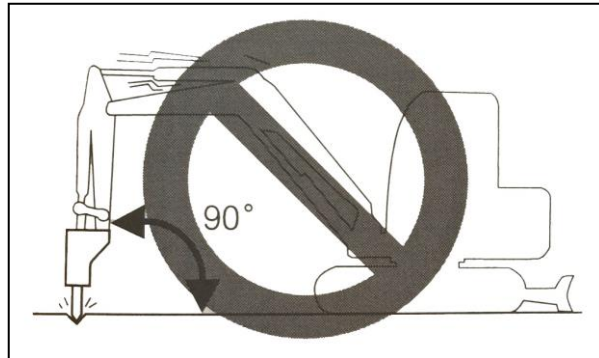

Do not break when the bucket bar is perpendicular to the ground.

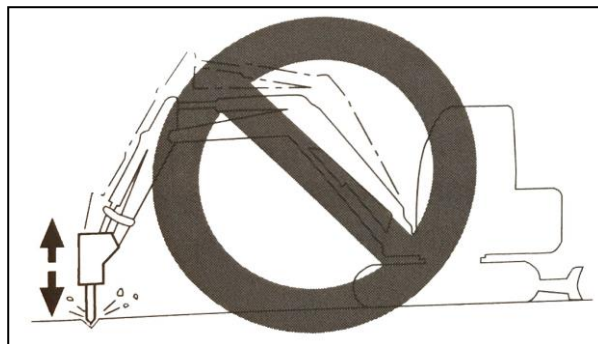

Do not break down by breaking down the hammer itself, breaking the object.

Do not use broken hammer to move the objects or blocks to be broken.

Turn the machine back and forth from time to time to cool the engine.

If the abnormal vibration of the hydraulic tube occurs, it may be the leakage of nitrogen in the accumulating device. Please check it as soon as possible.

Notice when stopping

Safe parking

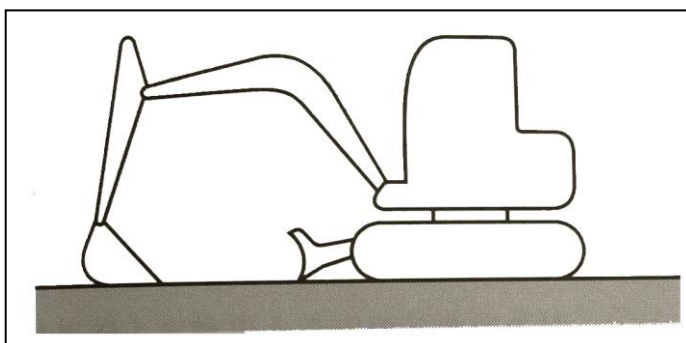

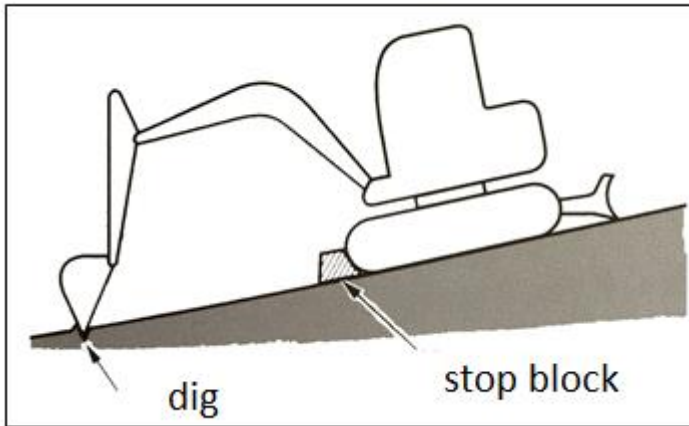

Stop the machine on the flat, solid and safe ground. Set the parking device.

If you have to park or lean on the ramp, stop the machine firmly and prevent the machine from moving.

When parking on the street, we should use grille, warning signs and lights to make the machine easy to see even at night, so as to avoid collision with other vehicles.

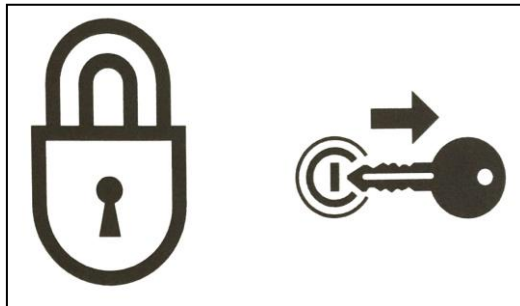

Before leaving the machine, do the following:

Drop the shovel and the shovel down to the ground.

Turn off the engine, take out the starting key.

During loading and unloading, the machine may overturn or drop. Please take the following safety measures:

Choose a solid and smooth ground and keep enough distance from the shoulder.

The inclined plane with enough strength and dimension is fixed to the truck compartment. The slope of the slope must not exceed 15 degrees. If the ramp is bent downward too large, support it with support or support.

Do not use a working device to load and unload the machine. This may cause the machine to overturn or drop.

Keep truck compartment and loading surface clean, no oil, sand, ice, snow and other foreign objects, so as to prevent machine sideslip. Clean the track.

Plug the cart wheel with a wedge to prevent the movement.

When loading and unloading the machine, follow the signal of the signalling member and walk slowly at low speed.

There is no way to change the line on the slope.

Do not swing / swing on the slope. The machine may turn over.

Rotary / compartment of the truck swing, footing may not stable enough, it should be slow.

If it is feasible, lock the door and cover after loading. Otherwise, it may be opened in the course of transportation.

Wedge is used to stabilize the track and then fasten the machine with the truck compartment by means of cables or chains.

Safety hoisting machine

Master and use the correct lifting gesture.

Check lifting equipment every day to see if any parts are damaged or missing, and replace them when necessary.

When lifting, please use a rope that can lift the weight of the machine.

The machine is hoisted according to the procedure described below. Do not operate in any other way, otherwise it may cause the machine to be out of balance.

Do not hoist when there is an operator on the machine.

When lifting, please proceed slowly so as not to overturn the machine.

When hoisting, keep all the staff away from the operation area. Do not move the machine above the top of the head.

After Each Use

⚠WARNING

- Before leaving the machine, do the following:
- Drop the shovel and the shovel down to the ground.
- Turn off the engine, take out the starting key.

Maintenance

⚠WARNING

- Mark the "do not operate" warning information
- When checking or maintaining a machine, if an unauthorized person starts the engine or touches control, it may cause serious injury.
- Before maintenance, please turn off the engine and take the key and carry it with you.
- Please mark "do not operate" warning information in the prominent places such as start switches or control rods.

Precautions for maintenance

Use the right tools



Do not use damaged or poor performance tools or design tools for other purposes. Use the tools that are suitable for the related work.

Regular replacement of safety key components

To ensure that the machine can be safely used in a longer time, it should be regularly refueling and inspected and maintained. To improve safety, replace key parts such as hose and seat belt regularly.

"Replaceable safety key components" refers to parts of aging, wear and functional degradation after reuse, and the performance of such components will change over time. These features can cause serious mechanical damage or personal injury, and it is difficult to judge the remaining life by checking or operating the sense of hand.

If any damage is found when it is visually looked, replace the safety key parts regularly, even though the specified replacement interval has not yet been reached.

Replace the fuel hose regularly. The fuel hose will wear away as time goes on, even though it has not shown any wear symptoms.

The first thing is to find out the wearing symptom is to replace it, no matter how to change the schedule.

To use the machine safely, please carry out inspection and maintenance regularly. The following safety critical components must be changed regularly to enhance safety. Damage to these components will cause serious injuries or fires.

List of security key components

Body		Safety key components of regular replacement	Replacement time
Fueling system		Fuel pipe	Every 2 years
		Fillers on the cover of the fuel tank	
Hydraulic system	Host	Hydraulic pipe (pump outlet)	
		Hydraulic pipe (pump suction port)	
		Hydraulic pipe (rotary motor)	
		Hydraulic pipe (walking motor)	
	Working device	Hydraulic pipe (moving arm cylinder)	
		Hydraulic pipe (pipe of bucket cylinder)	
		Hydraulic pipe (bucket oil cylinder)	
		Hydraulic pipe (swinging cylinder)	
		Hydraulic pipe (soil shovel cylinder)	
		Hydraulic pipe (pilot valve)	
		Hydraulic pipe (auxiliary pipe)	

Explosion-proof lighting



When checking fuel, lubricating oil, coolant or battery electrolyte, please use explosion-proof lamp to prevent fire or explosion. Otherwise, there may be an explosion and serious casualties.

The entry of unauthorized personnel is strictly prohibited

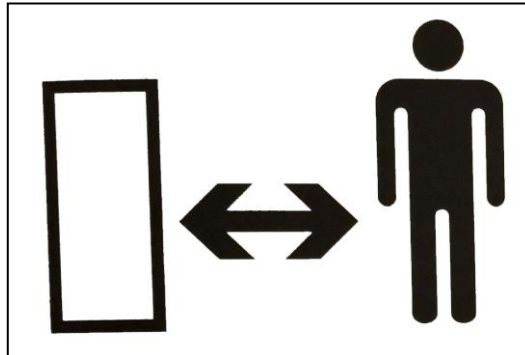

Please do not allow unauthorized personnel to enter the job area while doing homework. Please be careful when grinding, welding or using hammers. You may be injured by the debris that is flying out of the machine.

Operation area preparation

Select the stable and smooth operation area. Ensure proper lighting conditions, such as indoor operation, ventilation should be ensured.

Remove obstacles and dangerous goods. Remove the slippery area.

Keep the machine clean all the time

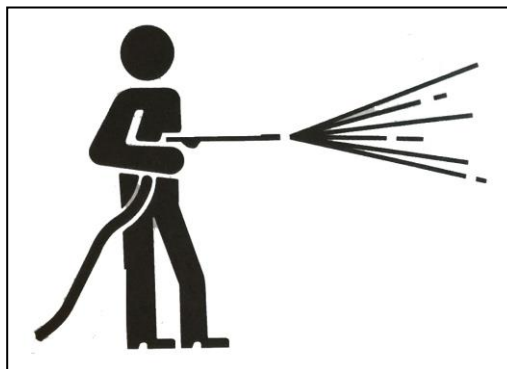

Before maintenance, the machine should be cleaned.

The engine is shut off before cleaning the machine. Cover electrical components to prevent water from entering the electrical system. Electrical components may cause short circuit or fault after being flooded. Do not use water or steam to clean batteries, electronic control components, sensors, connectors.

Turn off the engine before maintenance

If the engine is still running, lubricating or mechanical adjustment should be forbidden.

While the engine is running, there should be two people working as a team during maintenance. A person must sit on the driver's seat to shut off the engine immediately if necessary. This person must pay special attention to not touching the control rod and pedal, except when needed.

Another person who performs maintenance must ensure that his body or clothes are away from machine moving parts.

Far away from moving parts

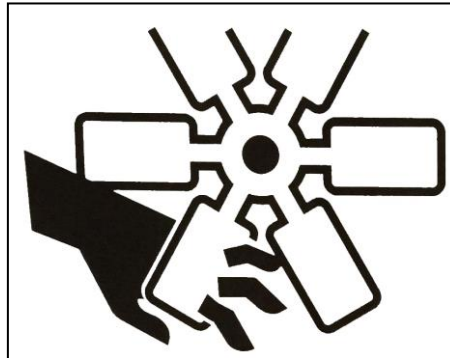

Stay away from all rotating and moving parts. If hand or tool is stuck into rotating or moving parts, it may lead to serious injury or even death.

If a tool or other object is thrown into or inserted into a fan or fan belt, these objects will be blown or chopped. Do not throw anything into or insert into the fan or fan belt.

Fasten the machine or any parts that may fall.



All mobile devices should be landed on the ground or at the lowest location before maintenance or repair.

Fixed excavator

If we must operate under the lifting machine or equipment, we always use wood block, Jack or other sturdy and stable support to fix it. Before it is firmly supported, it will not get under the machine or working device. This program is especially important for hydraulic cylinder operation.

Stable working device

When repairing or replacing bucket teeth or side teeth, the working device should be firmly secured to prevent accidental movement of machines.

Open the engine cover or cover to keep it stable

Be sure to fix the hood or lid before making the machine work. Please keep the hood or lid closed when the wind is heavy or when the machine is on the slope.

Put the weight in a stable position



In the process of dismantling or installation, we need to put the heavy objects or accessories on the ground for the time being. Don't let unauthorized personnel close to store such goods.

Precautions for refueling



No smoking or open fire near fuel point.

No fuel cap or gas can be removed when the engine is running or not cooled. Do not scatter the fuel on the high temperature surface of the machine.

Fuel the fuel tank in a well-ventilated area.

Do not fill up the fuel tank. There should be room for oil expansion.

The spilled fuel should be cleaned immediately.

Firmly tighten the fuel tank. If the lid of the fuel tank is missing, replace it only with the original one. The use of unlicensed and poorly ventilated fuel tank cover will cause internal pressure in the tank.

Prevent dust from entering

When installing and disassembling components, it should be carried out in areas without dust, cleaning workshops and cleaning parts to prevent dust from entering.

Cleaning surface

When installing and disassembling components, please ensure that the contact surfaces of components are clean. If the sealing groove of the contact surface is damaged, please contact your sales or service agent for repair or disassembly.

The thread tape and pin

You must use the new parts all removed the sealing ring and pin.

When installing, be careful not to damage or distort the thread tape.

Thread tape

Remain 1 or 2 rings of screws unwinding thread tape

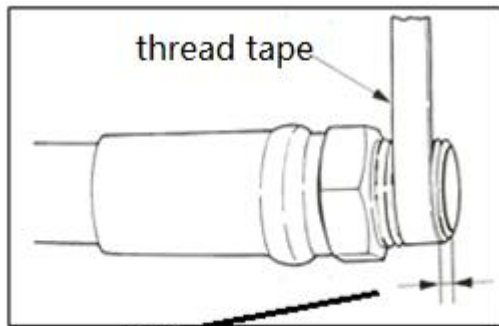

Remain 1 or 2 rings of screws unwinding seal ring

With thread tape wrapped plug.

Thread tape for winding thread, in 1 or 2 end plug will not leave around.

No fuel is used for cleaning

Fuel and lubricants are used according to season.

Please refer to the form below, select the appropriate fuel, lubricating oil and grease according to the temperature. No matter whether it has arrived at the appointed time, if the oil becomes too dirty or deteriorated, please replace it.

Do not mix the different brands of oil at the time of refueling. If you want to change the brand, please replace all the fuel / lubricating oil.

Fuel and diesel should meet the following specifications. The table lists the current diesel specifications in the world.

Diesel specification	Place	Diesel specification	Place
ASTM D975 No.: 1-D, S15	U.S.A Canada	ISO 8217DMX	International
Biodiesel Biodiesel mixed to B5 ASTM D6751, D7467			

Diesel oil tank

In order to maintain engine performance and service life, always use clean and high quality fuel.

In order to prevent freezing in cold weather, please choose the diesel that is still applicable when the actual temperature is at least 53.6°F below the expected minimum outdoor temperature.

Please use a diesel with a value of sixteen or more than 45 or more. When it is used in alpine or high altitude area, it needs sixteen fuel with higher value.

Use sulfur containing volume ratio less than 0.05~0.0015% fuel. (in the US or Canada, the use of ultra-low sulfur fuel) using high sulfur fuel may cause sulfuric acid corrosion of engine cylinder.

The use of kerosene is prohibited. Do not mix kerosene, used engine oil or residual fuel with diesel fuel.

Poor quality fuel will reduce engine performance or cause engine damage. The use of fuel additives is not recommended. Some fuel additives will cause engine performance degradation.

Metal content, such as zinc, sodium, magnesium, silicon and aluminum, must be limited to one millionth of the mass (1 mass ppm) or lower.

Safety measures for using biodiesel, the warranty requirements of engine manufacturers are invalid for machines that do not meet standard or deteriorated biodiesel.

Lubricating oil

API standard: American Petroleum organization; ACEA standard: European Automobile Manufacturers Association.

SAE standard: American Academy of Automotive Engineers

*: if the proportion of walking time in the total operation time is relatively high, the gear oil should be changed before the specified time.

** : please use water (soft water) when you want to use water. Do not use well water or river water. When the outdoor temperature drops below 32 °F, add coolant (antifreeze). The mixing ratio is determined according to the instructions of the manufacturer of the coolant.

***: the interval of hydraulic oil changing depends on the type of hydraulic oil being used. When using ordinary anti wear hydraulic oil, hydraulic oil should be changed every 2000 hours.

<ul style="list-style-type: none">• Position• Type• Oil sump• Hydraulic oil tank• Cooling system• Walking deceleration gear• Rotary motor gear• Slewing bearing• Working device• Rod• Type• Diesel fuel• Antiwear hydraulic oil	<ul style="list-style-type: none">• Cooling water (water + coolant)• Gear oil• Lithium-based grease• Types based on temperature selection• Coolant mixture• Replacement time• Every 250 hours after the first 50 hours• Every 2000 hours• Every 1000 hours• Every 50 hours• Daily or every 10 hours• When needed
---	---

Maintenance cycle

10 hour daily maintenance

<ul style="list-style-type: none"> • To pin the arm and the bucket arm and front device in grease (see page 4-13) • check engine oil level (see page 4-14) • check the oil level of the hydraulic oil tank (see page 4-14) • check the leakage of the hydraulic system (see page 4-15) • check fuel oil level (see page 4-16) • inspection of the oil-water separator (see page 4-16) • check the leakage of the fuel system (see page 4-17) <p>Check the cooling system and add coolant as required (see page 4-17).</p> <ul style="list-style-type: none"> • check the liquid level of the window cleaning fluid (see page 4-17) <p>Check the wear and tear of bucket teeth and side teeth (see page 4-18).</p> <p>Check whether the engine fan belt is cracked or worn, and the tightening force is suitable (see page 4-18).</p>	<ul style="list-style-type: none"> • Check whether there are cracks or welding of structural parts (see page 4-19). • check all the operating switches (see page 4-19) • Check all the external lights, speakers, control indicators and monitor lights (see page 4-19). • Start engine, check engine startup performance, check exhaust color at startup and exhaust color at normal working time, check whether there is noise or not (see page 4-19). • check all operating controls (see page 4-19) • Check bolts and nuts to prevent loosening and loss (see 4 to 20 pages). • check the tightness of track parts, whether there are loose parts, noise or breakage parts (rail links, track boards, supporting sprockets and steering wheels) (see page 4-20). • Clean engine air filter cover (see page 4-20).
--	---

50 hours of weekly maintenance

<ul style="list-style-type: none"> • Carry out every 10 hours / daily maintenance check (see page 4-21). • Injection of grease into the shaft socket (see page 4-21) • grease bearing (see page 4-21), check the fuel tank discharge 	<ul style="list-style-type: none"> • replacement of engine oil and filter cartridge (see page 4-21) <p>Check water tank, oil radiator and condenser core (see page 4-21).</p> <ul style="list-style-type: none"> • check the battery liquid and charge (see page 4-22)
---	--

valve (see page 4-21).	<ul style="list-style-type: none"> • Cleaning the fuel tank filling filter (see page 4-22)
------------------------	---

100 hour maintenance

<ul style="list-style-type: none"> • Carry out every 10 hours / daily maintenance and 50 hour maintenance check (see 4-23 pages). • Clean the filter core of the air filter (see page 4-23) 	<ul style="list-style-type: none"> • replacement of hydraulic oil (see page 4-24) • replacement of hydraulic oil filter core (see page 4-24)
---	--

200 hour maintenance

<ul style="list-style-type: none"> • Carry out all 10 hours / daily, 50 hours / weekly and 100 hours maintenance checks (see 4-25 pages). 	<ul style="list-style-type: none"> • replace engine oil and filter cartridge (see page 4-25)
--	---

250 hours of monthly maintenance

<ul style="list-style-type: none"> • Carry out all 10 hours / daily and 50 hour / weekly insurance. Check up (see page 4-26) • discharge impurities from the hydraulic tank (see page 4-26) 	<ul style="list-style-type: none"> • Check the wear and tear of front end work device pin and bushing (see page 4-26). • check the hose clamp of the fuel system (see page 4-26)
---	--

500 hours of maintenance per three months

<ul style="list-style-type: none"> • Carry out all 10 hours / daily, 50 hours / week, 100 hours, 250 hours maintenance check (see 4-27 pages). • replacement of fuel filter core (see page 4-27) • replacement of water tank coolant (see page 4-28) 	<ul style="list-style-type: none"> • replacement of hydraulic oil filter core (see page 4-29) • replacing the air filter cartridge (see page 4-30) • Check the oil level on both sides of the walking deceleration device (see page 4-30).
---	---

1000 hours of maintenance per six months

<ul style="list-style-type: none"> • Carry out all 10 hours / daily, 50 hours / week, 100, 250, 500 hours maintenance check (see 4-31 page). • Replacing hydraulic oil and cleaning oil filter (see page 4-32). 	<ul style="list-style-type: none"> • Replacement of walking deceleration device oil (each side) (see page 4-33). • check and adjust the cleaning valve (see page 4-33) • check the loosening of the bolt (see page 4-33)
---	---

1200 hour maintenance

<ul style="list-style-type: none"> • Carry out all 10 and 50, 100 hours of maintenance inspection (see page
--

4-34).

2000 hours of annual maintenance

- | | |
|--|--|
| <ul style="list-style-type: none">• Carry out all daily, 50, 150, 250, 500 and 1000 hour maintenance checks (see 4-34 pages).• Check generator and start motor (see page 4-34)• inspection of all earthquake resistant rubber blocks (see page 4-34) | <ul style="list-style-type: none">• Carry out and record the results of each cycle test (see page 4-34).• Inspect machine welding parts to see if there are cracks or damage to open welding or other structural parts (see page 4-34). |
|--|--|

4000 hours and two years of maintenance

- | |
|---|
| <ul style="list-style-type: none">• important components - periodic replacement (see page 4-35) |
|---|

10 hours / daily maintenance

Pin, bucket and front pin shaft

1. every 10 hours, the front connection pin is filled with grease.

As shown below, the working device will be on the ground and shut down the engine.

Press grease nozzle and grease gun to grease the specified point.

2. after the filling, the cleaning of the waste oil.

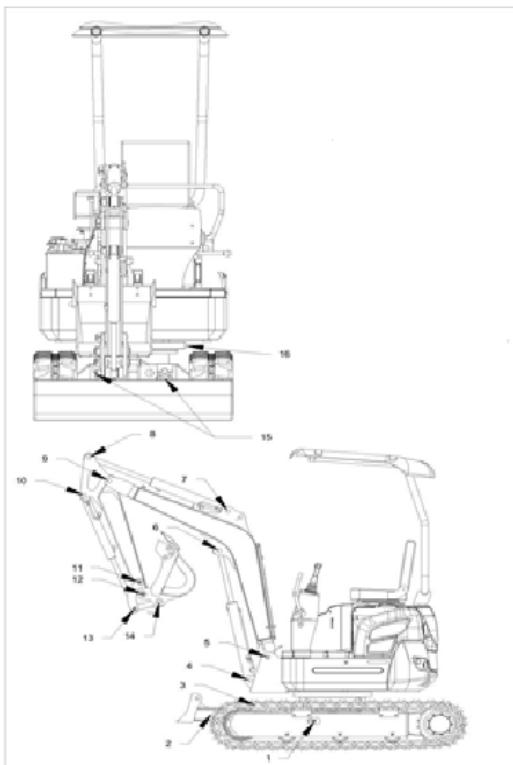

1. Fuel injection port

9. Connecting pin of arm and bucket

2. Front shovel and front shovel cylinder

10. Connecting pin of bucket and boom

connection pin	bucket oil cylinder
3.Connecting pin of bottom and front shovel oil cylinder	11.Connecting pin of bucket and swing rod
4.Upper and arm cylinder connecting pin	12.Joint pin of bucket and bucket
5.Connecting pin of arm and upper frame	13.Pendulum rod and push rod connection pin
6.Pin and arm cylinder connecting pin	14.Connecting pin of push rod and dug bucket
7.Connecting pin of movable arm and bucket rod oil cylinder	15.Connecting pin of lower frame and front shovel
8.Connecting pin of bucket rod and bucket rod oil cylinder	16.Revolving support injection port

Check engine oil level

1. Stop the engine and check it in 15 minutes. In this way, the oil can all flow
2. Use the oil level gauge to check the engine oil level.
3. Engine oil level should be located between H and L of oil level gauge.

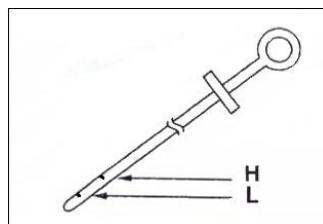
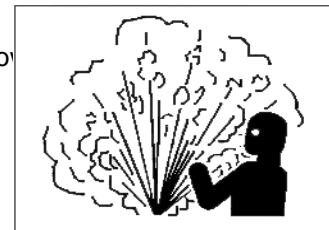

4. The oil can be added from the oil cover.

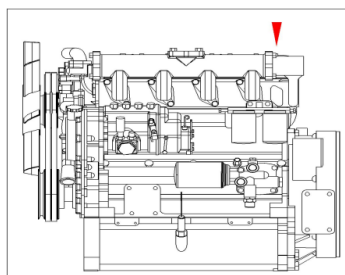

Check the oil level in the hydraulic oil tank

1. The machine is on the level and strong ground, as shown in the figure, extending the small arm to drop the bucket to the ground.

2. Turn off the engine.

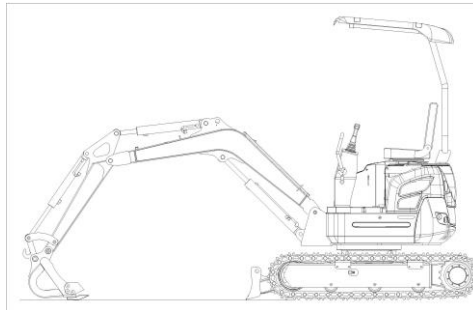

⚠WARNING

- When the hydraulic oil is working normally, the temperature of the oil rises.
- Before the maintenance of hydraulic components, we should first reduce the oil temperature. The gas in the hydraulic tank has pressure. First slowly release the plug on the hydraulic oil tank, release the air in the fuel tank, and then remove the filler cap or the upper plate cover safely.

3. After shutdown, switch the start switch to the "open" position, and move all the rod (including the walking rod) several times in the limit position to release the residual hydraulic pressure and then pull out the key.

4. Check the oil level, the oil level marking line is between the required marks, if the lower limit is lower, add hydraulic oil.

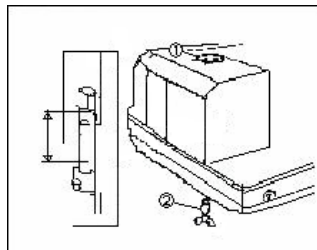

⚠WARNING

- The oil level should not exceed the "H" mark line. Excessive injection will cause equipment damage and oil leakage. The excess oil should be released from the bottom of the tank.
-

Check the leakage of the hydraulic system

Every day after work, check to make sure that there are any signs of leakage of hoses, hard pipes, joints, cylinders and motors. If there is any, check the leakage and repair.

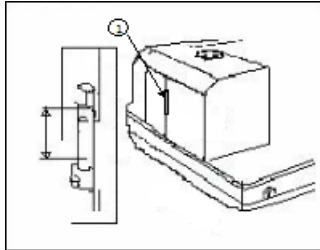

Check fuel oil level

⚠WARNING

- When adding fuel, special safety precautions should be taken to prevent explosion and fire.

1. Before filling the fuel, make sure that the on the excavator. By observing the oil level, injection volume, and add fuel to the fuel tubing, the capacity of the tank is 14.5 gallon.

2. Do not add excess fuel.

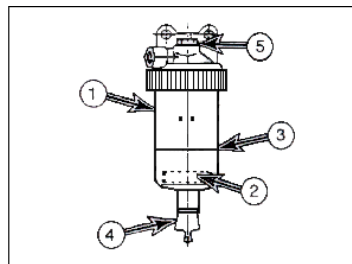

refueling hose is fixed confirm the fuel tank through the



3. Tighten the refueling cover after.

Note: if the ventilator hole is blocked, a vacuum is formed in the fuel tank. Fuel can not be fully supplied to the engine. Therefore, keep the respirator hole clean.

4. Check the fuel indicator in the driver's cab for normal operation.

Attention: of course, when the oil reaches 3 liters or less, the fuel level warning light is on.

Note: after the completion of the operation, fuel can be injected and the volume of the tank is 14.5 gallon.

Inspection of oil-water separator

1. Open the hood, check if the container of oil-water separator, water, floats floating red.
2. Release the water when floating to the warning line.
3. Release the water release valve at the bottom of the container.
4. Close the valve carefully after the discharge is finished.
5. Plug on the top of oil-water separator can't be reused. If the plug is loose, replace and tighten.

Check the leakage of the fuel system

Check all parts of the engine to make sure that the fuel system is not leaking. If there is oil leakage, check the cause and repair.

Check the cooling system, if necessary, to add coolant

⚠WARNING

- Before lifting the lid of the engine, let the engine cool down, so that the lid can be loosened slowly without leaving any residual pressure.
- When the engine is running, clean the water tank, stand next to the running engine or be careful when working. When working, make sure the parts are firmly fixed.
- Do not easily lift the lid of the water tank, observe the coolant level in the reserve tank.

1. When the engine is cooled, uncover the lid of the water tank and check the liquid level of the coolant. If necessary, add a coolant to the water tank, as shown in the following table. It can be protected by adding coolant.

Ambient temperature	cooling water	Ant freezing fluid
(15°F)	80%	20%
(5°F)	73%	27%
(-5°F)	67%	33%
(-15°F)	60%	40%
(-20°F)	56%	44%
(-30°F)	50%	50%

Check operation table cleaning

1. Check the cleaning situation of the driving workbench. There is no hindrance to the operation view.
2. The operation table is clean and clean. The driver can drive without obstacle.

Note: when cleaning operation workbench, do not flush wiring harness to prevent unnecessary troubles in electrical system. After cleaning, pay attention to the protection of the environment.

Check the bucket teeth and lateral teeth are worn

1. Check the wear of 1 of the bucket teeth each day.
2. Replace the badly worn bucket teeth in time, otherwise the tooth seat 2 will be exposed.

Check whether the engine fan belt is worn or tighten

⚠WARNING

- If the fan belt is too loose, the engine will overheat, and it will not work properly and cause wear. Too tight will cause damage to bearings and belts of pumps, generators.

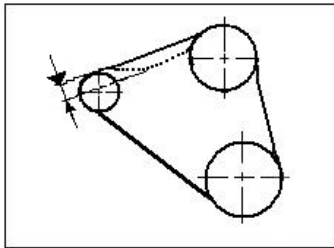

1. check every 10 hours.
2. turn off the engine, in the fan belt the pulley wheel and the generator according to the middle band to check its strength. The pressure is 73 FT.lbs (10kg), and the belt falls.8 - 12 millimeters. As shown in Figure 4 - 18. Adjust the belt when necessary.
3. check whether the engine belt is worn or broken, and whether the joint is damaged. If there is any situation above, replace the new belt.

Adjust the tightness of the belt

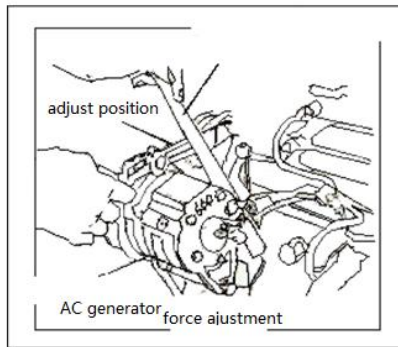

Note: if the belt is skewed, adjust it.

1. Release the adjusting bolt and adjusting bolt of the adjusting plate.
2. Tilt generator to adjust the belt rising force.
3. Adjust and tighten the bolts and bolts.
4. Idle the engine for 5 minutes, then re adjust the belt tension.

Inspection of structural fracture and welding crack

When checking and lubricating the machine every day, check whether there is any damage. Repair or replace before operation.

Check the working status of all external lights, speakers and control indicators.

1. Start the switch to the "open" position and observe the indicator lights.
2. Repair all light bulbs at this time.
3. Press the horn and repair or replace it if there is any trouble.
4. Open and check all the external working lights, replace the damaged bulbs and broken lenses.

Start the engine, check the starting state, observe the exhaust color at start and run, and check if there is any abnormal noise.

Check the working conditions of all controllers

⚠WARNING

- The hydraulic oil will fully heat up before the operation at low temperature. Refer to the heating steps in the operation section of this manual. The hydraulic oil is circulate at all components once (including all cylinders, walking motors and rotary motors). The low temperature hydraulic oil in pipes and components need to be heated before working normally. Otherwise, it will damage the hydraulic cylinder and the hydraulic motor.

1. Check the controller at fixed speed.
2. Open the low temperature hydraulic system to start heating up.
3. Remember all slow or abnormal movements. Find out the reason and fix it before you start work.

Check whether there are loose or shedding bolts and nuts

"Check on bolts and nuts"

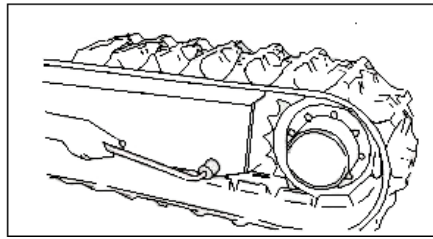

Check whether there are too tight, too loose, worn and damaged components (track links, track boards, supporting wheels, steering wheels, driving wheels).

1. Check every day including all parts of the crawler part for loss, damage or wear. "track strength"
2. Top up two crawlers, two motor walking speed test.

Cleaning engine air suction filter

1. Remove the lock spring fixed outer cover.
2. Clean the air filter inside.

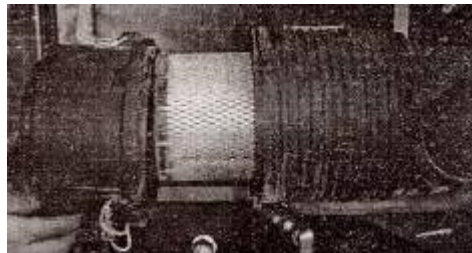

50 hours / weekly maintenance

Carry out all 10 hours / daily maintenance checks

Lubricated Slewing Support

1. Add two or three pumps of grease in the nozzle.
2. Lift the bucket 7.87in, turn the platform two times, 90 degrees each time, lubricate the rotating bearing.

Fuel tank oil discharge valve

Open the valve at the bottom of the tank to release water and sundries.



Change oil and filter core

After initial operation for 50 hours, replace oil and filter cartridge, once every 200 hours.

Cleaning oil radiator, water tank and air conditioner condenser

⚠WARNING

- Clean radiator and use high-pressure steam or water to ensure that the relevant personnel are in the proper working position.
- High pressure can damage the radiator and oil cooler.

1. During the cleaning process, the workers wear appropriate safety products. (Safety, safety shoes, etc.).

2. Clean the radiator and water from the radiator and water tank with high pressure steam or water. The cleaning should be carried out from the outside of the engine parts and then cleaned from inside to remove dust and debris.

Attention: cover the inlet of the air cleaner assembly to prevent water and other media from entering the engine.

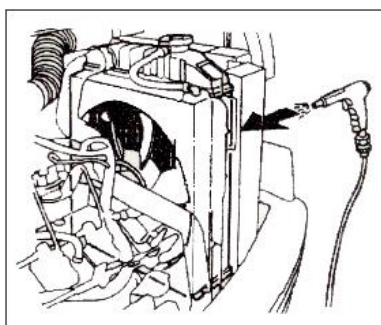

Check the level and state of the battery

Check the state of the battery, "battery".

Battery separator

Ventilatory cover

Water scale line

Battery

Positive plate

Negative plate

Shell

A partition

Battery compartment

Water filling hole

positive terminal

negative terminal

Clean up the inlet of the fuel tank

Open the lid of the fuel tank and clean all impurities in the filter.

⚠WARNING

- Be careful when filling or repairing fuel tanks, so as to prevent fire or explosion.
- Immediately clean up excess spilled oil.

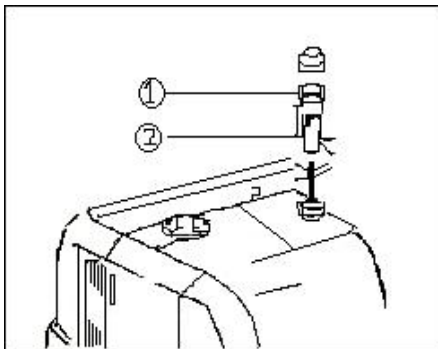

100 hour maintenance

Carry out all 10 hours / daily and 50 hour / weekly maintenance checks.

Filter core for cleaning air filter

▲Warning

Do not clean or move air filters when the engine is running. If we use compressed air to clean parts, we should take appropriate eye protection measures.

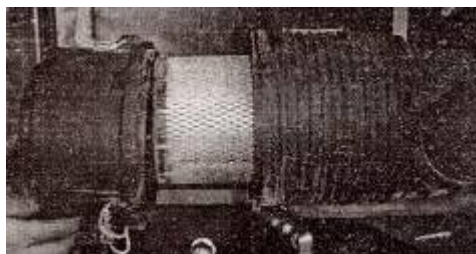

1. Install the air filter parts, take into the cover, and filter parts and components into the air cleaner.

Note: if the indicator board displays "open", the air cleaner must be opened.

Note: replace filter cartridge once every 500 hours / three months.

2. The filter core is cleaned with compressed air from inside and outside. The pressure should not exceed 205kPa (0.2MPa).

3. Clean air filter shell and side cover.

4. Install the air filter and the side cover correctly. Tighten the wing nut with the hand and do not tighten with any tools.

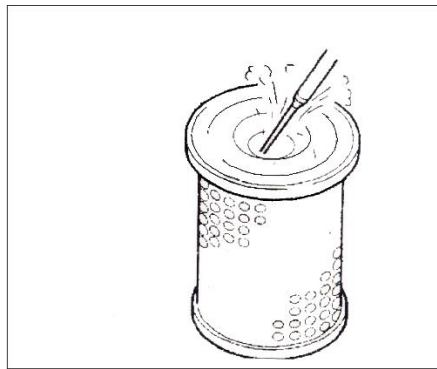

Replacement of hydraulic oil

For the new machine, it will replace the hydraulic oil for the first time after 100 hours, and then it will be carried out every 1000 hours.

Replacement of hydraulic filter core

⚠WARNING

- After the machine works well, the hydraulic oil is very hot. Before any hydraulic components are maintained, make the hydraulic oil cool down sufficiently.
- The hydraulic oil tank has air pressure, slowly loosens the screw plug on the hydraulic tank to release the pressure; then it can safely remove the filling cover or cover plate and remove the water from the tank.
- Be sure to clear up the water and spoils at the top of the hydraulic tank, especially the filling ports and the installation ports of the filter elements.

Attention: after the first operation for 100 hours, replace the hydraulic oil filter cartridge and replace it every 500 hours. Refer to the replacement program "replace the hydraulic filter core".

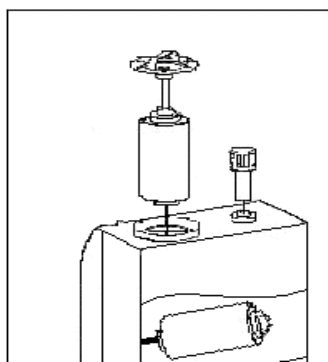

200 hour maintenance

Carry out all 10 hours / daily. 50 hours / week

Ch
Att

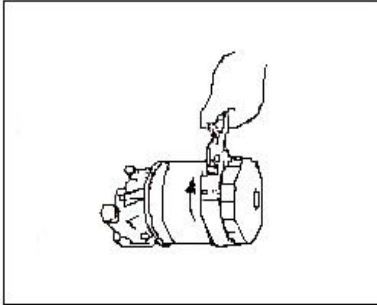

after 50 h

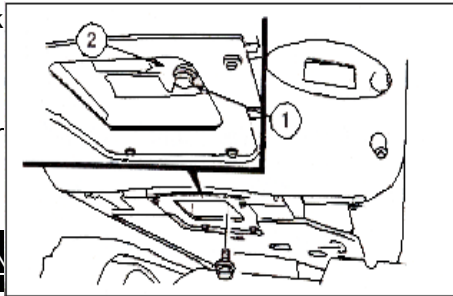

- When the engine is hot, do not change the engine oil, and cool the engine before changing the oil or filter element.

1. Under the bottom of the oil pan, remove the oil drain plug, drain the oil to the container, install the oil stopper and tighten it.

2. Replace the oil filter element. The oil filter element is a rotary installation type, and the filter element is removed.

3. Install the new filter element, use a small amount of oil around the oil filter ring, rotate the filter element until the top contact with the washer, then tighten the 3 / 4 turn.

4. The correct type of oil can be selected according to the recommended lubricant list.

5. Engine start, check oil pressure.

6. Engine shut off; check whether there is leakage in the oil filter element.

250 hour / monthly maintenance

Carry out all 10 hours / daily and 50 hour / weekly maintenance checks, and discharge water and impurities from the hydraulic tank.

1. The machine will be fixed on the horizontal plane, and the straightening bucket will put the bucket on the ground.

2. Shut down the engine

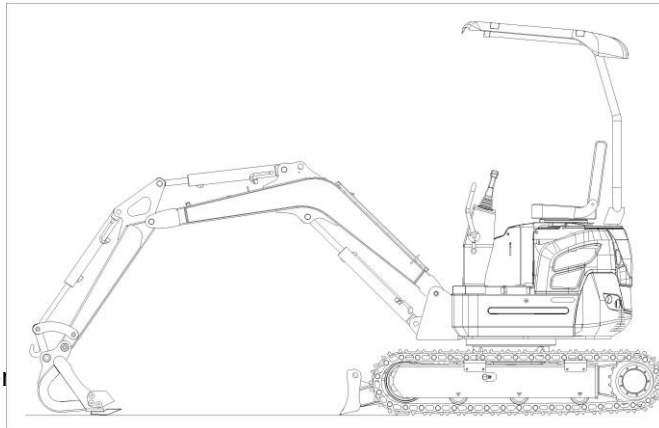

3. After the oil temperature is lower tank.

ain the oil

4. Slowly release the drain plug at the bottom of the tank. 2. Drain the water and impurities. Then install the oil stopper and tighten it.

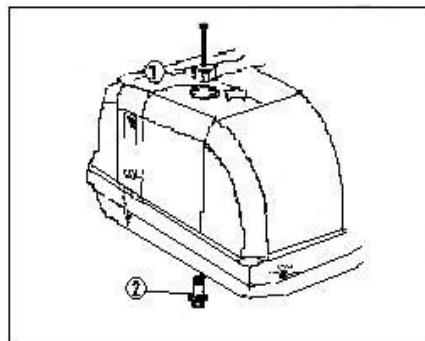

Check the wear and tear of the connecting pin and the axle sleeve of the front work device.

Check the clamping situation of the hose of the fuel system

500 hours / three months maintenance

Carry out all 10 hours / day, 50 hours / week, 100 hours and 250 hours maintenance check.

Replacement of fuel filter core

⚠WARNING

- After the engine is cooled, the three filter core is replaced. Be careful with the fire and prohibit smoking.

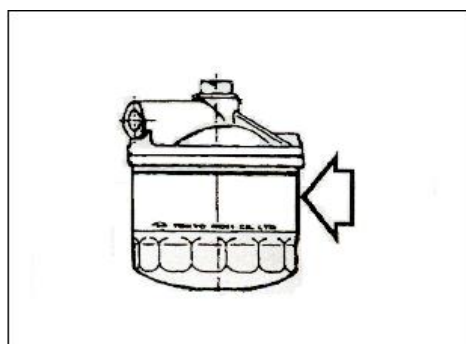

1. Replace the fuel filter core of the engine.
2. Put one at the bottom of the fuel filter small container.
3. Fuel from the filter seat under spin filter shell, remove the fuel filter.
4. After cleaning the top of the filter, install a new fuel filter, and then rotate the fuel filter until the washer contacts with the top; rotate 1 / 2 turn again.

Attention: apply fuel to the fuel filter washer.

Attention: fill the fuel filter hood with clean fuel, which can discharge the air in the fuel system.

5. Start the engine, the engine is running 1-2 minutes after shutdown, check whether there is leakage phenomenon.

Replace the radiator coolant

⚠WARNING

- First, allow the engine to cool down, and then slowly loosen cover, to reduce the internal pressure.
- During the operation of the engine, the radiator is cleaned. Be careful when working on a running engine. Make sure that the safety rod is in the lock-in position and hang the signs, which remind people that the excavator is being repaired.
- If there is no need to remove the radiator cover, observe the coolant level in the storage tank.

1. Open the top of the radiator slowly to relieve pressure.
2. Place a container under the radiator and unscrew the drain valve.
3. The discharge valve is closed after the coolant is discharged.
4. Add the cleaning liquid to the cooling system.
5. Idle engine until the coolant temperature is expressed in "green area" and run for another 10 minutes.
6. The engine is cooled.
7. Discharge the cleaning fluid and fill the system with water.
8. Run the engine again, so that the water will circulate completely.
9. Drain all water; fill the system with antifreeze that is suitable for ambient temperature. Refer to the coolant configuration table.

10. Do not install radiator cap, run the engine to discharge air, and allow radiator to fill 1.97in below the top.

11. Drain the coolant in the reserve tank, release the liquid from the evaporation tank and then pour the new coolant into it.

Replacement of hydraulic oil filter core

⚠WARNING

- Be sure to clear up the moisture and spoils at the top of the hydraulic tank, with special attention to the filling ports and the installation ports of the filter elements.

Attention: after 100 hours' operation, replace the hydraulic oil filter cartridge, then replace it every 500 hours.

1. Slowly loosen plug exhaust, then loosen the filter;
2. Unscrew the bolt, remove the upper cover and the sealing washer, then loosen the nut, and remove the dirty filter element.
3. Remove the original filter core.
4. Install new filter element and O ring, install valve, spring and upper cover.
5. Check the liquid level in the hydraulic tank, and add hydraulic oil when needed.

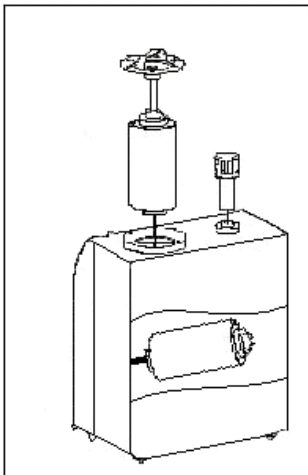

Replacing the air filter cartridge

Change each operation for 500 hours / three months

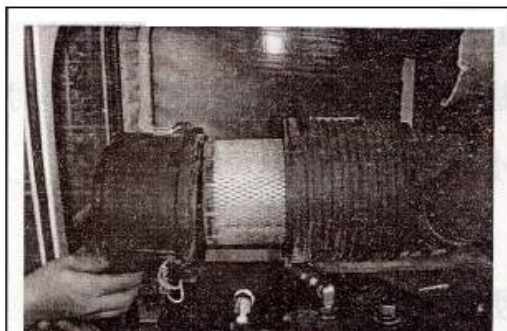

Check the oil level of the walking reducer on both sides of the walking device

⚠WARNING

- After the operation of the machine, the lubricating oil is very hot, cut off all the work system to cool down. Before removing the screw plug on the shell, the bolt should be loosened and the air pressure is released

Note: after the first operation for 500 hours, drain off the old oil and replace it every 1000 hours.

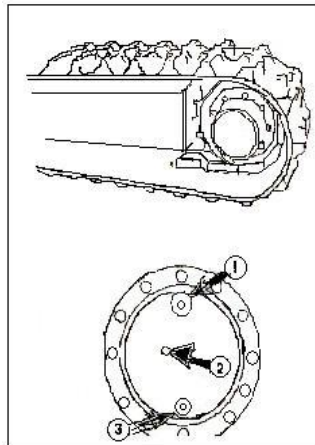

1. Make sure the machine works on a solid level. Remove the old oil from the decelerator.
2. Turn the track until the oil port is at the end of the table.
3. Remove the plug, add oil until the oil level reaches the oil port, the plug is installed.
4. Repeat this step on another walking motor.

1000 hours / six months of maintenance

All 10 hours / day, 50 hours / week, 100 hours, 250 hours and 500 hours for maintenance check.

Replacement of hydraulic oil

⚠WARNING

- After the machine works normally, the hydraulic oil is very hot, so the oil must be cooled before the hydraulic components are repaired.
- There is pressure in the hydraulic tank, slowly release the plug on the upper part of the hydraulic tank to release pressure, and then the oil tank cover or the upper cover can be safely removed after pressure relief.



⚠WARNING

- Confirm that the loot or moisture on the hydraulic tank has been cleaned, especially around the liquid filled hole and filter hole.

Attention: according to the type of excavator and the special device installed in the front part of the excavator, such as crusher, etc. Hydraulic oil may need to shorten the replacement period.

Note: after the first job 100 hours. Replace hydraulic oil, and then do it every 1000 hours.

1. Stop the machine on a solid level. As shown in the picture, the straight arm will put the bucket on the ground.
2. Turn off the starting key and stop.
3. Slowly open the tank above and the pressure relief cover to plug. Remove the plug, the old oil is discharged into a capacity of 120 liters in the container.
4. Then install the plug and tighten the

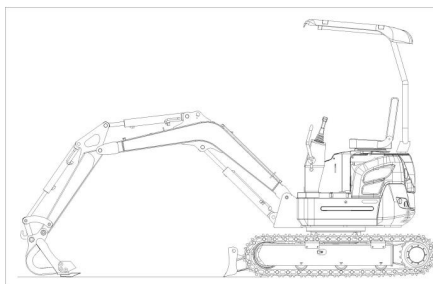

⚠WARNING

- Be careful to spray out the oil when the oil plug is unloaded.

5. Open the top cover ①.

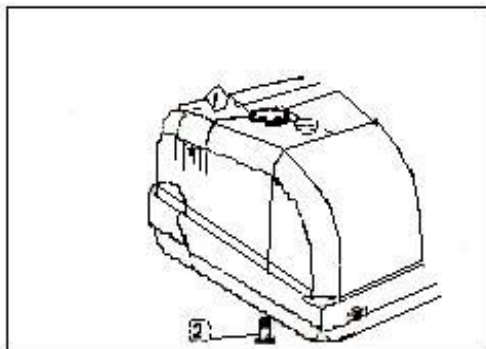

6. Fill the tank and check the oil level with the ruler on the side of the fuel tank.

7. Install the top cover.

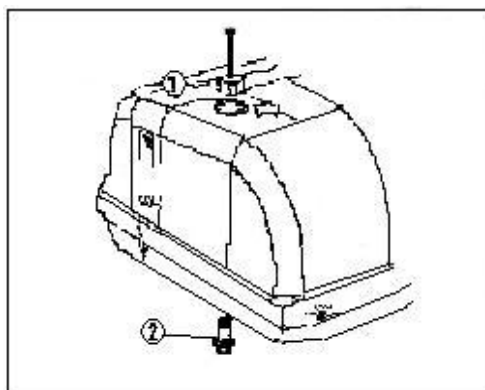

Replace the travel reducer oil (one /side)

⚠WARNING

- After the equipment works, the lubricating oil is very hot, and the working system is stopped to cool it. Before the motor shell is removed and the screw plug at the hole is checked, the screw plug is slowly loosened to relieve the pressure.

Note: 500 hours after the first work

Drain the old oil and do it every 1000 hours.

Note that the gear box capacity is 0.16 gallon, and the oil can not be mixed.

1. The machine is parked on a solid level.

2. Rotate the track until the plug ① to ③, as shown in the drawing.

3. In the plug put a container, remove the plug (① and ③) discharge of oil.

4. Install screw plug ③, then remove the plug at the bottom hole, and injects new oil from hole ① until the oil level reaches hole ②, and install plug (① and ②).

5. Repeat the above steps on another walking motor.

8.68 ft·lb - 9.22 ft·lb

Note: the knob two screw torque of 33.93 ft·lb - 37.62 ft·lb, 8.68 ft·lb - 9.22 ft·lb Intermediate plug

Check and adjust the cleaning valve.

Check the bolt torque.

1200 hour maintenance

Carry out all 10 hours / daily, 50 hours / weekly and 100 hours maintenance check.

2000 hours per year maintenance

Carry out all routine, 50150250500 and 1000 hours of maintenance check.

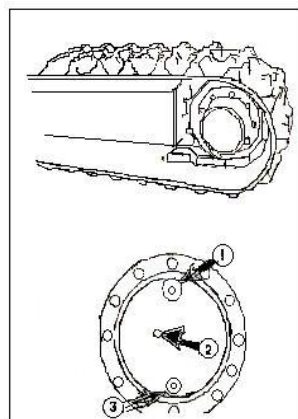

Check generator and start motor (completed by rhino heavy industry designated agent).

Check all rubber shock proof devices

Carry out and record the results of periodic inspection

Check whether there are cracks, welding or damage in welded structure.

4000 hours / two years of maintenance

Important component / periodic replacement

In order to ensure the safety of operation and work, periodic inspection should be carried out, as well as to increase safety and replace the following parts, which are easily worn, heated or fatigued, and should be replaced in a set period even if the parts look good.

Often replace related parts, such as washers, O rings, and only use pure products.

main component		Periodic replacement parts	Replacement time
engine		Fuel hose (oil tank to filter)	2 years or 4000 hours
		Fuel hose (fuel tank to fuel injection pump)	
		Heating hose (heater connected with engine)	
Hydraulic system	body	Pump oil suction hose	
		Pump out of oil hose	
		Revolving hose	
	Working device	Arm cylinder hose	
		Bucket cylinder hose	
		Bucket oil cylinder hose	
		Pilot oil hose	

Electrical system

Attention: it is strictly forbidden to dismantle electrical wiring and components, and negotiate with Rhino heavy industry agency before negotiation.

Battery

⚠WARNING	
<ul style="list-style-type: none"> • Before the battery is maintained, make sure that the engine has stopped functioning and the start switch is placed in the "OFF" position. • A battery can produce hydrogen. In particular, the uncharged battery has the danger of explosion. Make sure that the flame, combustible matter and sparks are away from the battery, and the 	

electrolyte is diluted sulfuric acid. The battery should be carefully placed, and the electrolyte will cause combustion. When electrolytes are made on clothing or skin, rinse immediately with plenty of water. If the electrolyte is in the eye, rinse immediately with plenty of water and see the doctor as soon as possible.

- When installing the battery, keep your safety glasses on.
- When the battery is dismantled, the grounding terminal should be disassembled first, so that the electric spark or arc will be avoided and the explosion will be avoided. When installing the battery, connect the "+" positive connection". To ensure the reliable connection of the terminal.

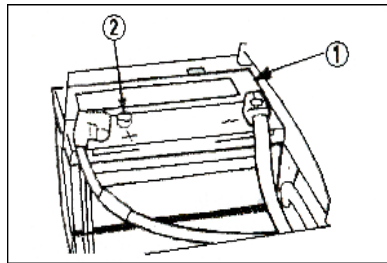
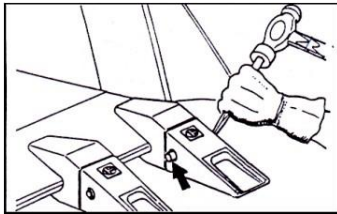

1. In cold winter, when the engine is started and preheated, the battery consumption is large, and the performance of the battery decreases when the temperature decreases.

2. In a particularly cold weather, the battery can be removed at night and placed in a warm place, which helps to improve the performance of the battery.

3. Check the level of the battery.

Note: the battery installed in the original plant is maintenance free, and the battery liquid only maintains at the right level under normal conditions.

4. Check the charging state of the battery by inspecting the indicator set in the interior and brightness.

- Green: normal
- Black: insufficient charging, check the generator.
- Transparent: electrolyte is not enough, replace with new battery.

Note: the colors displayed vary according to the manufacturer, and refer to the relevant instructions of the battery.

Bucket tooth replacement

⚠WARNING

- Because there may be metal objects flying out, so helmets should be worn when replacing bucket teeth, and gloves and eye protectors should be protected.
- The bucket is lifted up, and the surface of the bucket is placed firmly on the ground after the arc. The engine is stopped, the control handle is locked, and the bucket tooth is replaced again.

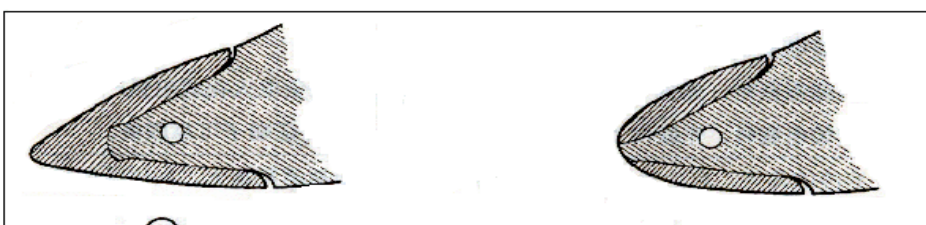

1. Establish a benchmark, often check whether the wear or fracture is expanded, do not allow the bucket teeth to wear seriously, so that the bucket teeth are leaking outside, referring to the picture.
2. Replace the shovel teeth, with a hammer and punch pin and remove lock washer.

3. After the bucket teeth are removed, use the knife to scrape the bucket seat as far as possible.
4. Insert the new bucket teeth and install the lock pin.
5. Change the bucket teeth and change the lock pin at the same time.

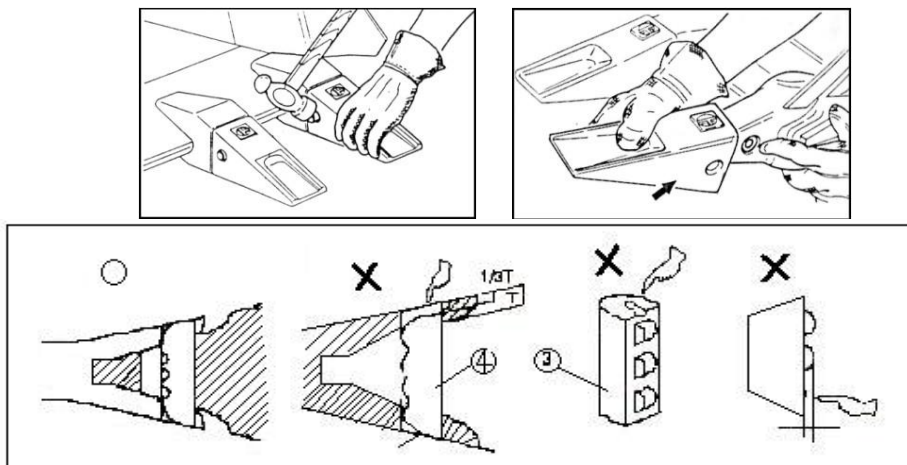

Check the lock pin. Change the lock pin when the following situation exists.

1. When two surfaces are straightened, the lock pin is too short.
2. The rubber caterpillar has a side seam, and the steel ball is easy to slip.
3. Extruded steel ball causes the ball to shrink inside.

Change the bucket O ring

⚠WARNING

- Because metal objects may spatter, gloves, protective glasses and safety helmets should always be worn when replacing pins.

1. Check the O ring of bucket. If there is wear, replace it if necessary.

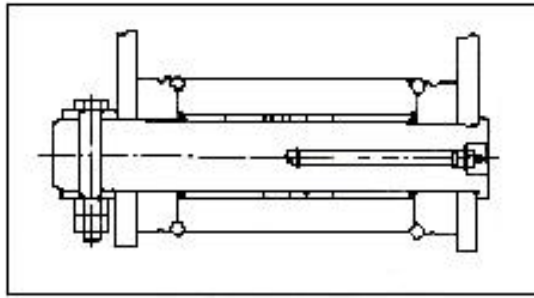

2. Shift the O ring 1 to the bushing 2, then remove the bucket pin 3, and pull out the bucket rod or bucket connecting rod pin.

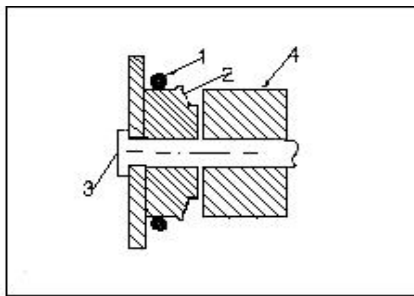

3. Remove the old O type ring, install the new O type ring 1 to the bushing 2, confirm that the O groove and the bucket bushing on the connecting rod 3 have been cleaned up.

4. Aim at the bucket connecting rod and the rod pin hole and install the bucket pin.

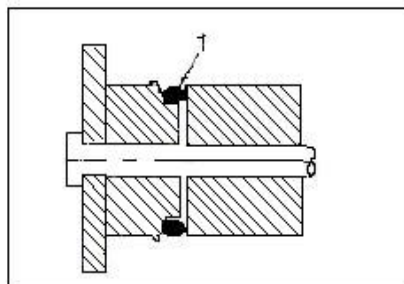

5. Roll O ring 1 into the O slot.

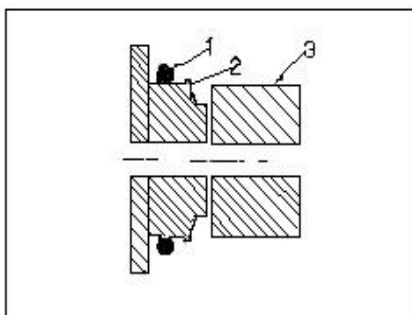

Check the lock pin. Change the lock pin when the following situation exists.

1. When two surfaces are straightened, the lock pin is too short.
2. The rubber track has a side seam, and the steel ball is easy to slip.
3. Extruded steel ball causes the ball to shrink inside.

Change the bucket O ring

⚠WARNING

- Because metal objects may spatter, gloves, protective glasses and safety helmets should always be worn when replacing pins.

Adjustment method and data

Install a new bucket

1. If the new bucket is installed, the inner ear size of the bucket and the width of the bucket bushing shall be measured.
2. Two dimensions are reduced, that is, the size of the gasket on both sides.

▲Warning

When checking the clearance of the bucket connection, the bucket is in a free state. At other times, the bucket is lowered to the ground or the bucket is fixed with the support block, the engine is stopped, the control mechanism is locked, the Warning card is suspended and the bucket movement is prevented.

A method of adding a gasket when the bucket is installed and replaced.

1. When the bucket is connected, the bucket is lifted and the bucket bar extends outward. Reduce the moving arm and make the bucket teeth 1.97 ~ 3.94in away from the ground. This position is convenient for size measurement.

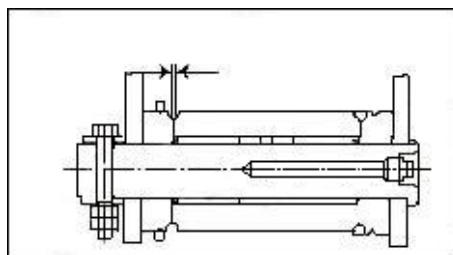

2. After the O ring installation, push the bucket to one side, check the gap between the other side of the bucket and the bucket bushing, the total gap between the inner ear and the bushing section of the

bucket should be 0.01in, 0.03in., which will aggravate the wear and the gap is too large, so the gap is too large, generating too large noise and loose action.

3. Push the bucket to the other side and check the gap again.

4. When adjusting, remove bolts and pins, remove or increase gaskets as required, and use the same number of gaskets on both sides.

Crawler tensioning

⚠WARNING

- A safe measure of a crawler's tightness requires 2 people, one driving a excavator on one side of the track to leave the ground, and the other to measure the size, and must be very careful to guard against the movement or movement of the machine. Open the excavator to a flat floor, if necessary, use support block.
- The pressure of the track adjustment cylinder is very high, so do not reduce the pressure suddenly. Do not loosen the whole circle at a time, and relieve the pressure slowly. At the same time, the body must be far away from the valve body.

The track chain joint pin and liner wear in normal work, so that the tightness of the crawler is reduced, so periodic adjustment is necessary, and it is also the need of normal work.

1. Check up the tightness on the side of the track.

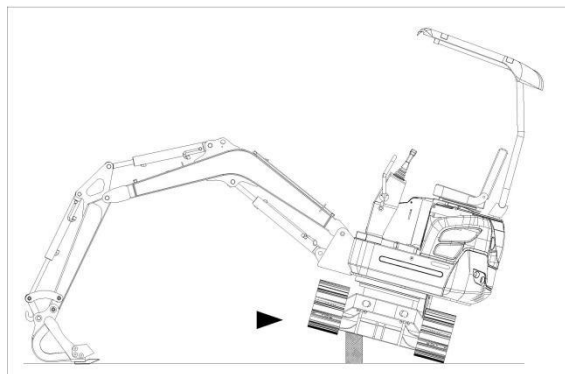

2. Measure the clearance between the maximum outer rim of the wheel and the lowest track of the caterpillar track, and the recommended value is 0.39in to 0.79in (equivalent to a=7.09 to 7.48in).

Note: if there are too much dirt, dust or other substances on the chassis assembly, the measurement is not allowed. Therefore, the chassis should be cleaned before measuring.

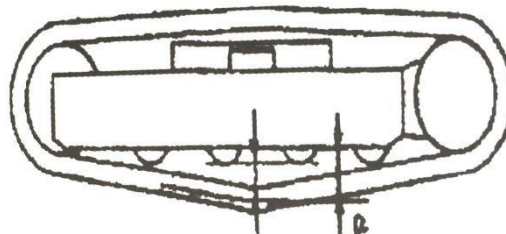

Note: with caterpillar tracks and rubber belt machine, inspection and adjustment steps in the same.

3. If we measure the clearance between the middle supporting wheel and the upper link of the rail link, it should be 0.79 ~ 1.38in.

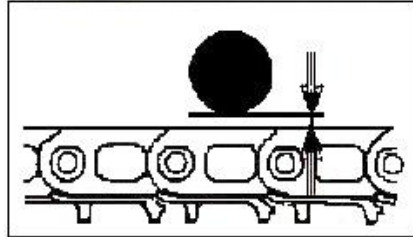

1. The gap between the rubber crawlers is 59.84in.

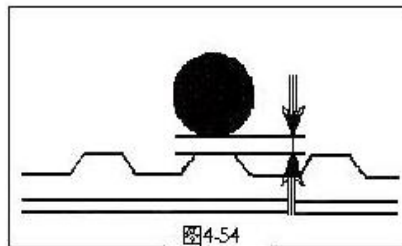

⚠WARNING

- The pressure of the track adjustment cylinder is very high, so do not reduce the pressure suddenly. Do not loosen the whole circle at a time, and relieve the pressure slowly. At the same time, the body must be far away from the valve body.

5. Track tightness adjustment is achieved by installing 1 in the middle part of the chassis side frame. Add butter, increase the length of the tight cylinder, and extend the length of the expansion cylinder. The higher the pressure of the track spring body of the steering wheel is, the higher the pressure is.

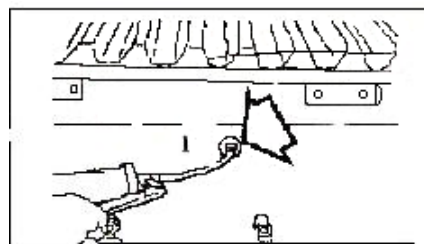

6. If the track does not have enough clearance, it means that the adjustment is too tight. At this time, the steering wheel 3 can be retracted by releasing the butter in the cylinder.

Attention: adjusting valve torque to 43.52 ft·lb–64.91 ft·lb .

Maintenance under special conditions

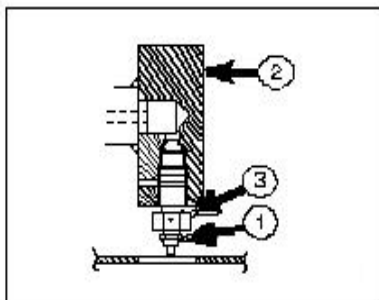

Condition	Maintenance requirements
<p>Work in mud, water, or rain</p>	<ol style="list-style-type: none"> 1. Check whether the joint is loose. 2. After work, clear up the mud, rock and gravel on the machine, check whether the welds are damaged, and whether the parts are loose. 3. Complete the daily lubrication and maintenance. 4. If working in acid rain or corrosive substances, rinse the affected parts with clean water.
<p>Work in a particularly dusty or hot environment</p>	<ol style="list-style-type: none"> 1. More frequent cleaning of the intake filter. 2. Wash oil radiator and water tank and remove embedded dust and booty. 3. More frequent cleaning of air and filter cartridges. 4. If necessary, check and clean up the motor and generator.
<p>Working in a rock environment</p>	<ol style="list-style-type: none"> 1. Check whether the chassis and track assembly is damaged or excessive wear. 2. Check whether the joints and bolts are loose or damaged. 3. Further relax the track. 4. Check more frequently whether the bucket or crusher is damaged or excessive wear. ◦ 5. If necessary, install a top frame and front frame to avoid damage to falling objects.
<p>Work in a particularly cold area</p>	<ol style="list-style-type: none"> 1. Use fuel, hydraulic oil and lubricating oil that are suitable for ambient temperature. 2. Check the antifreeze fluid with the hydrometer to ensure that it has the corresponding antifreeze performance. 3. Confirm the temperature environment of the battery, especially when it is cold, remove the battery and store it in a warm place at night. 4. Timely move away mud on the body, to prevent the damage to the equipment.

Inspection of bolts and nuts

All fasteners are checked after 50 hours of work and 250 hours after the first work. If there is any loosening or loss, new products should be tightened or added, and torque wrenches must be used.

⚠WARNING

- Clean the fastener before tightening.
- If the counterweight bolts are loose, negotiate with Rhino heavy industry agent.

Attention: rust, sand, dust and mud should be removed during installation.

When installing, lubricate to reduce wear.

Long-term storage

Condition	Maintenance requirements
Clean	1. Clean the chassis and the caterpillar assembly with a high pressure water gun.
Lubrication	1. Perform all normal lubrication content. 2. Apply a rustproof oil on the surface of the exposed metal parts, such as hydraulic cylinder piston rod and so on. 3. Apply oil to all control connections and control cylinders.
Battery	1. After filling the battery, remove the battery or battery lead and store it.
Cooling system	1. Check whether the liquid level of coolant storage tank is in the normal range. 2. Check the antifreeze level of the antifreeze fluid or coolant every 90 days or 750 hours per hour.
Hydraulic system	1. Refer to the "heating method of hydraulic system" specified in this manual, start the engine once a month.

Treatment of hose

A leak of oil or fuel can cause a fire.

The hose shall not be twisted, bent or impacted.

No twisted, bent or cracked pipes, metal pipes or hoses shall be used, otherwise, it may burst.

Tighten the loosened joint.

Be careful when operating high temperature and high pressure components

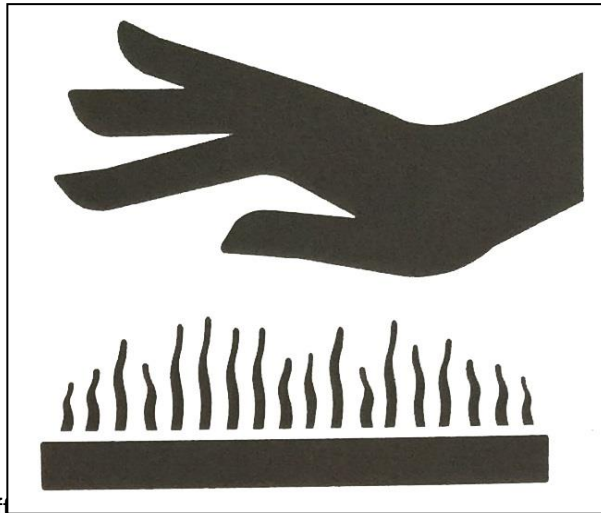

Please turn off the engine and wait for the machine to cool down for further maintenance.

Engines, exhaust pipes, radiators, hydraulic pipes, sliding parts and many other parts of the machine are very hot when the engine just stalls. Touching these parts can cause scalds.

Engine coolant, hydraulic oil and other oils are also under high temperature and high pressure.

Please be careful when loosening the lid or plug, do not touch hydraulic oil. In this case, the operation of the machine will cause burns or injuries due to the ejection of hot oil.

Be careful when operating a high temperature cooling system

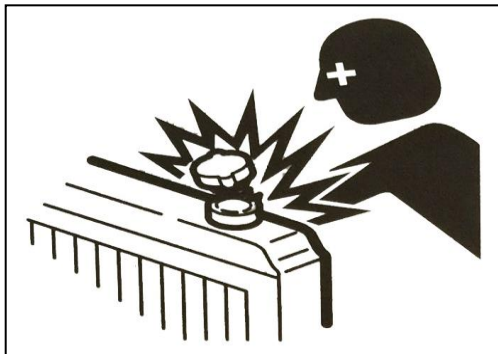

Cooling water, do not remove the radiator cap or drain plug. Shut off the engine and wait until the engine and cooling water cool down. Then slowly release the radiator cover, release the internal pressure, and then take it off.

Be careful of the internal pressure of oil

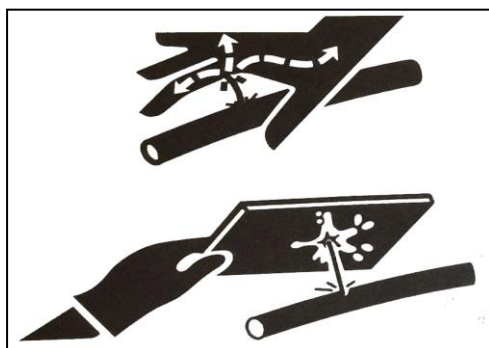

After the engine is turned off, the pressure in the hydraulic oil pipe will last for a long time.

The internal pressure should be thoroughly discharged before the maintenance operation is carried out.

The high pressure of hydraulic oil can pierce the skin or eyes, cause serious injuries, cause blindness or even death. Remember, the hydraulic oil leaking from the small hole is almost invisible. When checking leakage, you should wear goggles and thick gloves, and use cardboard or glue.

Plywood protects skin from damage caused by hydraulic oil ejection.

If hydraulic oil invades the skin, it will be removed within a few hours by surgeons who are familiar with such injuries.

Before the operation of the hydraulic system, the pressure should be relieved first

Before the hydraulic system is released, the hydraulic oil may be ejected if the lid or filter or pipe is disconnected.

Release the exhaust plug slowly to release the tank pressure.

When removing the plug or screw or disconnecting the hose, it should stand on one side and release it slowly, so as to gradually release the internal pressure and then remove it.

The oil or oil plug may be ejected from the pressure in the motor fuel tank. Please release the oil plug slowly to release the internal pressure.

Please be careful with the splash when you use the hammer

When using hammer, pins or metal chips may splash everywhere. This may cause serious injuries.

When you hammer the hard metal parts such as pins, bucket teeth, side teeth or bearings, please wear protective devices such as goggles and gloves.

When you tap the pin or bucket teeth, make sure that there is no one around.

Watch out for high pressure oil



In track tension device, grease is at high pressure. If the tightening force is adjusted, if the procedure is not specified, the grease relief valve may fly out, leading to injury.

Do not loosen the butter pipe.

Slowly release the butter relief valve. Do not turn it over and over.

Do not place your face, arms, legs or body in front of the grease relief valve.

When the grease relief valve is released, the valve will fail if there is no grease flowing out. Please contact the Rhinoceros service agent for maintenance.

No disassembling track tightening device

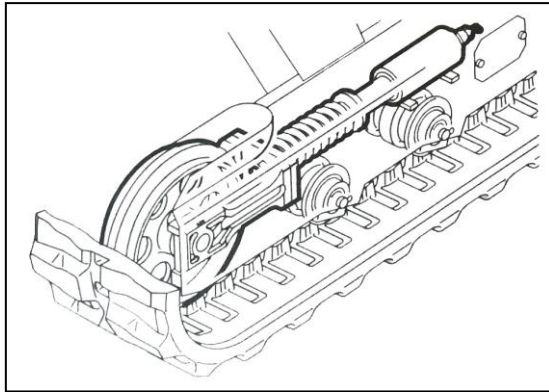

The track tightening device is equipped with a strong spring. When the track tightened device is broken apart, the spring will pop up, resulting in serious injury. The track tightening device shall not be dismantled.

Disconnect the battery line

Please disconnect the battery line before carrying out the electronic system operation or welding. First disconnect the negative (-) battery cable. When reconnecting, finally connect the negative battery cable.



Please be careful when dealing with the battery

The battery contains sulfuric acid, and it will hurt your eyes or skin if you touch it carelessly.

In case of contact with eyes, rinse immediately with, and quickly seek medical treatment.

If you swallow, you should drink plenty of water or milk and seek medical advice immediately.

If sulfuric acid touches skin or clothing, it should be washed away with plenty of water immediately.

Wearing goggles and gloves should be worn when operating the battery.

The battery can generate flammable hydrogen, which may cause explosion. Keep away from fire sources such as open fires, Mars or kindled cigarettes.

When the electrolyte level is checked, a flashlight is used.

Before checking or handling the battery, ensure that the starting switch is closed to turn the engine out.

Please be careful not to allow metal tools or any metal objects to contact the electrodes and cause short circuits.

When the electrode is loose, the electric spark will be produced. Be sure to tighten it up.

Make sure that the lid of the battery is tightly closed.

When the battery is frozen, do not charge or start over the engine, otherwise it will explode. The frozen battery is heated to 59°F before use.

Please do not use the battery when the liquid level is lower than the lower limit. Otherwise, it will accelerate the aging of battery and shorten the life of battery. At the same time, it can cause rupture (explosion).

Do not add the distilled water to the upper limit. Otherwise the electrolyte will be leaked out. Contacting the liquid can damage the skin or corrode the machine parts.

Clean the surrounding area of the electrolyte level line with wet cloth and check the liquid level. Do not use dry cloth to clean, otherwise it will cause electrostatic accumulation, combustion or explosion.

Using battery charging line to jump start

When starting the engine with battery charging line, please follow the following correct steps to connect the cable. When cable connection is wrong, it will cause discharge and battery explosion.

Don't let the "machine" and "rescue machine" together.

Don't take the positive battery charging line (+) and negative (-) collision or contact wire clamp machine.

When connecting, first connect the positive part of the battery charging line to the positive (+) terminal. When disconnecting, the negative cable is first disconnected from the negative terminal.

Be sure to firmly connect the wire clip.

Connect the last clamp of the battery charging line to the place away from the battery as far as possible.

When using battery charging line to start the engine, goggles and gloves should always be worn.

The size of battery charging line and clamp is suitable for battery capacity. Do not use corroded or corroded battery charging line and clamp.

Make sure that the battery of the rescue machine is the same as the battery of the problem machine.

Please use a certified welding service agent for welding repair

When welding is necessary, qualified personnel must be carried out in a well-equipped workplace. In order to prevent damage to any part of the machine caused by excessive electric current or electric spark, please observe the following items.

The wiring of the battery should be disconnected before the electric welding.

Do not continue to apply 200V or larger voltage.

The location shall be connected within the range of 39.37in. away from the welding part. Do not connect the grounding terminal to the electric control device / instrument or connector.

Ensure that there is no seal ring or bearing between the welding area and the grounding terminal.

Do not connect the grounding terminal to the pin or hydraulic cylinder of the working device.

Before welding to the body, the connector of the electrical control device should be disconnected before operation.

The vibration of the operator

Tests carried out by the machine to the vibration of the operator showed that the vibration of the operator's upper limb was lower than that of 98.4in./s, and the vibration of the body at the seat was lower than that of the 19.69in./s.

Waste disposal

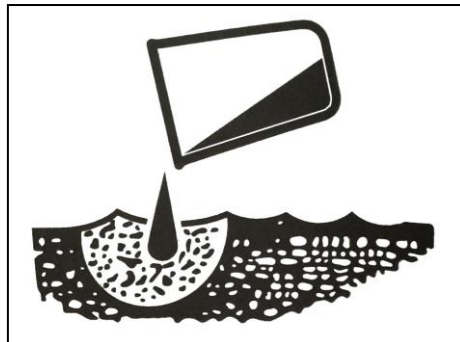

Make sure that the waste oil discharged from the machine is collected in the container. The improper treatment of waste oil will cause harm to the environment.

Please comply with applicable laws and regulations when dealing with hazardous substances such as lubricating oil, fuel oil, coolant, solvent, filter and battery.

Treatment of hazardous chemicals

Direct contact with harmful chemicals can cause serious injury.

The harmful chemicals used in this machine include grease, battery electrolyte, coolant, paint and adhesive.

Please handle hazardous chemicals carefully and properly.

Maintain the machine by adopting a program of routine repair and maintenance in accordance with the following recommended procedures. It is recommended that the general condition of any tool be examined before it is used. Also refer to the engine manufacturer's instruction manual for additional information about engine maintenance. The following chart is based on a normal operation schedule.

Maintenance Interval	Maintenance Point
Every 25 hours	Please make a simple record /feedback here.
Every 50 hours	Please make a simple record /feedback here.
Every 100 hours	Please make a simple record /feedback here.
Every 500 hours	Please make a simple record /feedback here.

Troubleshooting

Use the table below to troubleshoot problems before contacting service personnel or your local dealer. If the problem continues after troubleshooting, call your local dealer for assistance.

The problems identified during maintenance should be taken in time to adjust the maintenance of hydraulic or electrical system, and contact the designated suppliers of Nortrac Excavator nearby.

Cause of failure	Solutions
Vehicle powerless	<ul style="list-style-type: none"> • Check and clean the overload valve of the multiplex valve • check whether the gear pump is leaking and replacing the gear pump • Check whether the hydraulic oil or hydraulic oil filter core is empty or blocked.
Automatic falling of the arm	<ul style="list-style-type: none"> • check whether the arm cylinder is damaged or not <p>Check whether the multi-channel valve arm stem is in the middle</p> <p>Multi valve arm valve stem wear gap large</p> <ul style="list-style-type: none"> • one-way valve card or clutter
Whole car without electricity	<ul style="list-style-type: none"> • Check whether the fuse is broken or loosened • check whether the battery line is loose • check battery relays
The inability of the bucket to move slowly	<ul style="list-style-type: none"> • Check whether the oil seal of the bucket cylinder is damaged or not • Check whether there is any foreign body or scratch on the valve stem of multi way valve. • Check whether the tubing tubing is blocked
Walking unilateral weakness	<ul style="list-style-type: none"> • Check the outlet of multi valve valve body • wear and tear of walking motor • Back transfer head oil seal damage internal leakage
How to install the caterpillar	<ul style="list-style-type: none"> • first before using the shovel and arm of excavator digging machine to support, leave the ground • track the tracks onto the steering wheel, and put the other head on the driving wheel to compress it down. • start digging machine, walking backwards slowly push the side of the handle
The engine does not start	<ul style="list-style-type: none"> • check whether the diesel pump has oil or air • inspection of diesel pumps

	<ul style="list-style-type: none"> • diesel filter core has water or blockage
Engine high temperature	<ul style="list-style-type: none"> • cleaning the radiator to check the lack of antifreeze • check whether the thermostat is open • check the fan belt
Walk without high speed	<ul style="list-style-type: none"> •Check whether the high and low speed control switch is loose. •Check whether the solenoid valve, thread head, coil and spool are jammed. • check the pressure of the high speed tubing
The inability of the shovel	<ul style="list-style-type: none"> •Check bucket oil cylinder and oil seal •Check whether the valve stem of the multi-channel valve is stuck in the stagnation
Inability to walk	<ul style="list-style-type: none"> •Check the overload valve • wear and tear of walking motor •Back transfer head oil seal
Rotary strong one side, weak another side	<ul style="list-style-type: none"> •Check the rotary motor overload valve • change the main oil pipe of the rotary motor and have the variable • multi valve valve body vent

Parts Diagram

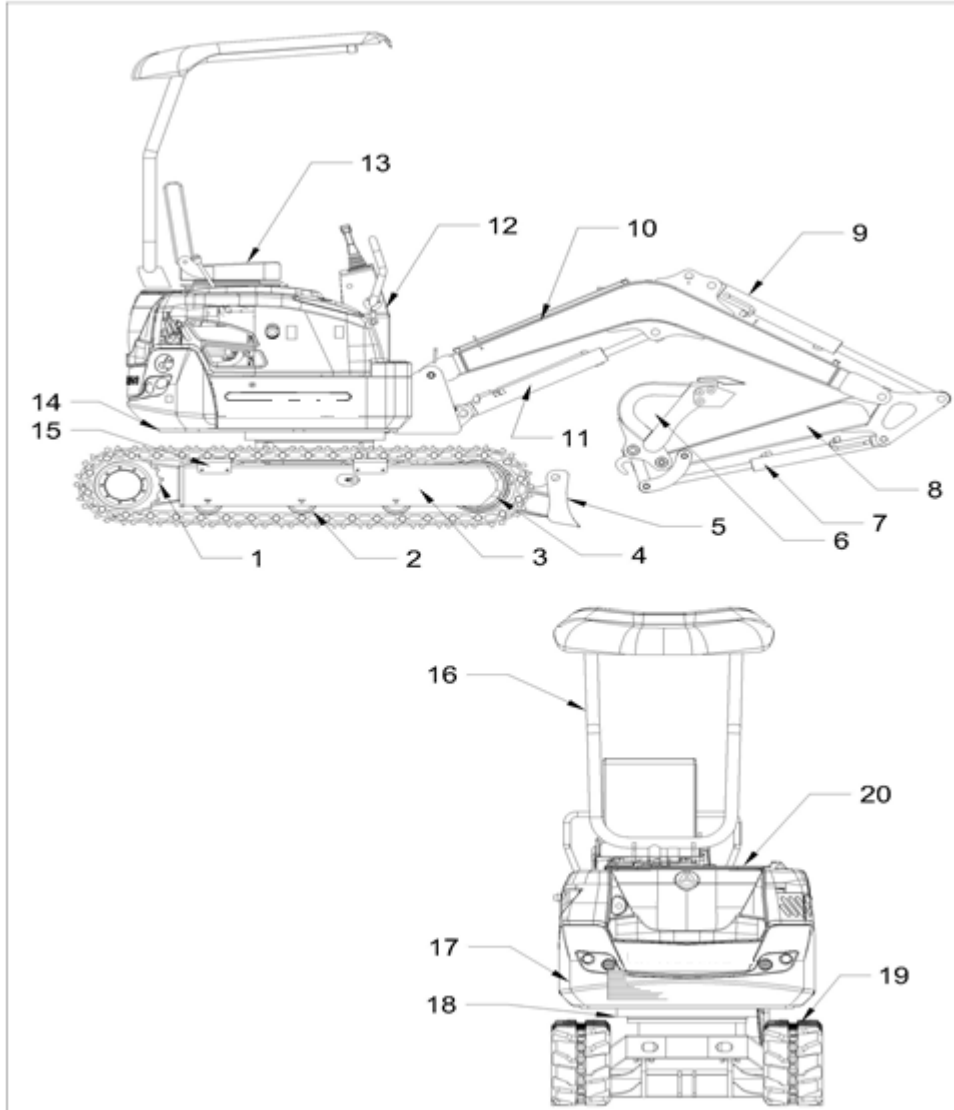

Parts List

Reference	Part Description	Quantity
1	Driving wheel	2
2	Support wheel	2
3	Lower frame	1
4	Guide wheel	2
5	Front shovel	1
6	Bucket	1
7	arm cylinder	1
8	Bucket rod	1
9	arm cylinder	1
10	Boom	1
11	Cylinder	1
12	Operating table	1
13	Chair	1
14	Upper frame	1
15	Roller	1
16	Roof rack	1
17	Counterweight	2
18	Slewing bearing	1
19	General caterpillar	2
20	Operating table	1

Replacement Parts

- For replacement parts and technical questions, please call NorTrac Customer Service and Technical Support at **1-800-521-0438**.
- Not all product components are available for replacement. The illustrations provided are a convenient reference to the location and position of parts in the assembly sequence.
- When ordering parts, the following information will be required: item description, item model number, item serial number/item lot date code, and the replacement part reference number.
- Northern Tool + Equipment reserves the right to make design changes and improvements to product lines and manuals without notice.

Limited Warranty

The Mini Excavator sold by NorTrac; a division of Northern Tool & Equipment Company, Inc. (NTE). NorTrac will repair or replace, at its option, any part(s) thereof of the NorTrac Dozer that are shown to be defective in material and/or workmanship, under normal use during the applicable 12-month warranty period. NorTrac wants your equipment to operate well and will assist you on repairs. **All warranty repairs submitted after the first 60 days of ownership are subject to a \$100.00 labor deductible, per covered repair.** After the labor deductible has been met, all warranty repairs and replacements will be made without charge for parts or labor at a pre-authorized service center. All parts replaced as a result of this limited warranty become the property of NorTrac and must be returned to NTE upon request. All parts replaced will become a portion of the whole and will be warranted for the duration of the original equipment warranty.

Length of Warranty

The limited warranty begins on the original date of purchase and extends to 12 months for consumer household use. For the commercial end user, the limited warranty continues for 6 months (180) days from date of original purchase. Commercial use is defined as: intended for the purpose of monetary reward or gain through the loan, rental or hire of equipment - OR- any manner that is primarily intended for or directed toward commercial advantage "For Profit" or private monetary compensation, or use by any governmental agency.

Qualifications for Limited Warranty

This applies to the original purchaser of the equipment. The limited warranty is non-transferable. Owner is to provide proof of purchase. Equipment was purchased in the United States from authorized representatives of NorTrac and/or NTE, Company, Inc. **To Obtain Service** Contact NorTrac Warranty Administrator by calling 1-800-521-0438 to report a possible warranty issue and to receive repair authorization from the Warranty Administrator. Detailed failure information can also be provided in hard-copy written form along with contact information to the address listed at the bottom of this page.

After receiving authorization from NorTrac Warranty Administrator, and the address of the pre-authorized service center, take the equipment to the service center during their regular business hours. **All transportation costs after the first 60 days of ownership, are the responsibility of the equipment owner.**

Exclusions and Warranty Disclaimers

This limited warranty applies to equipment used in its original form. Any unauthorized modifications or any incorporation or use of unsuitable attachments or parts will automatically void this limited warranty. This limited warranty does not include parts affected or damaged by accident and/or collision, normal wear & tear (light bulbs, filters, belts, motor brushes, brakes, fuses and switches, tires and tubes, clutch linings, engine tune up, wheel alignment and lubrication), fuel contamination, or from failure to follow instructions contained in the User Manual for the equipment. Warranty is void if adjustments are made to the injection pump fuel delivery system, starting fluid or ether is used to start or run the engine or regular maintenance and service is not performed as prescribed by the operator's manual during the warranty term. The cost of normal maintenance of the equipment is the responsibility of the owner.

Limited Warranty

This limited warranty does not cover defects that result from accident, misuse, lack of maintenance, improper repairs, neglect or use of replacement parts and accessories which do not meet NorTrac specifications.

Disclaimer of Consequential Damage

Any implied warranty of merchantability or fitness for a particular purpose, to the extent that either may apply to any NorTrac TM tractor or crawler / bulldozer, shall be limited in duration to the periods of the express warranties shown above, and to the extent permitted by law any and all implied warranties are excluded. In no event will NorTrac or NTE Company, Inc. be liable for any loss of income, loss of time or use of the product, transportation, hiring of alternative services, commercial loss or any other incidental, consequential, or special damages and / or expenses. Some states do not allow limitations on how long an implied warranty lasts and / or do not allow the exclusion or limitation of incidental or consequential damages, so the above exclusions and limitations may not apply to you. This limited warranty gives you specific legal rights which may vary from state to state.



Distributed by:

Northern Tool & Equipment Company, Inc.

Burnsville, Minnesota 55306

www.northerntool.com

Made in China