

AD-4212C-300
AD-4212C-600
AD-4212C-3000
AD-4212C-6000
AD-4212C-301
AD-4212C-3100

Production Weighing Unit

INSTRUCTION MANUAL



1WMPD4001992D

© 2016 A&D Company, Limited. All rights reserved.

No part of this publication may be reproduced, transmitted, transcribed, or translated into any language in any form by any means without the written permission of A&D Company, Limited.

The contents of this manual and the specifications of the instrument covered by this manual are subject to change for improvement without notice.

Windows and Excel are registered trademarks of Microsoft Corporation.

CONTENTS

1. INTRODUCTION.....	3
1.1. Features	3
1.2. Compliance	6
2. UNPACKING THE BALANCE.....	8
2.1. Unpacking.....	8
2.2. Installing the Balance	10
3. PRECAUTIONS	12
3.1. Before Use	12
3.2. When Building Into a System	13
3.3. During Use	16
3.4. After Use.....	16
3.5. Power Supply	16
4. OPERATION OF WinCT-AD4212C.....	17
4.1. Changing the Weighing Speed Using WinCT-AD4212C	18
4.2. Calibration	18
4.3. Changing the Baud Rate Using WinCT-AD4212C	20
5. SMART RANGE FUNCTION.....	21
6. COMMUNICATION SPECIFICATIONS.....	22
7. MAINTENANCE.....	30
8. TROUBLESHOOTING.....	31
8.1. Checking the Balance Performance and Environment	31
8.2. Asking For Repair.....	32

9. SPECIFICATIONS 33

10. EXTERNAL DIMENSIONS 35

11. OPTIONS..... 36

12. TERMS/INDEX 38

1. INTRODUCTION

This manual describes how the AD-4212C series balance works and how to get the most out of it in terms of performance.

Read this manual thoroughly before using the balance and keep it at hand for future reference.

1.1. Features

- A Weighing Unit, suitable for building into a production line system. The weighing unit is compact, with a width of 59 mm.
- A Super Hybrid Sensor (SHS) is used to provide high resolution and high response speed.

Model	Weighing capacity	Minimum weighing value	Stabilization time *1
AD-4212C-300	320 g	0.001 g	0.5 second (0 - 30 g), 1.0 second (30 - 320 g)
AD-4212C-600	620 g	0.001 g	0.5 second (0 - 30 g), 1.0 second (30 - 620 g)
AD-4212C-3000	3200 g	0.01 g	0.5 second (0 - 300 g), 1.0 second (300 - 3200 g)
AD-4212C-6000	6200 g	0.01 g	0.5 second (0 - 300 g), 1.0 second (300 - 6200 g)
AD-4212C-301	51 g ^{*2}	0.0001 g	1.3 seconds
	320 g	0.001 g	1.0 second
AD-4212C-3100	510 g ^{*2}	0.001 g	1.3 seconds
	3200 g	0.01 g	1.0 second

*1 With **FAST** selected under good environment

*2 Smart range (Refer to "5. SMART RANGE FUNCTION".)

- The AD-4212C series can output the weighing digital data directly. Therefore, the AD-4212C series (the weighing unit) can be connected to a personal computer or a PLC directly.
- Dust-protected and Protected Against Splashing Water (Complying with IP65). The AD-4212C series has a patented shock absorber under the weighing pan and can cope with movement in all directions, protecting the weighing unit from an actuator malfunction.
- Windows Communication Tools (WinCT-AD4212C), allows easy confirming of the weighing data by using a Windows-based personal computer.
Windows is a registered trademark of the Microsoft Corporation.
- When connected to an optional remote controller, an AD-8922A, AD-8923-BCD or AD-8923-CC, the remote controller can receive the weighing data and manually perform re-zero and calibration.
The AD-8922A can output the data using BCD, comparator or analog out by selection of the option installed in the AD-8922A.
The AD-8923-BCD outputs the data using BCD and the AD-8923-CC outputs the data using CC-Link.
Note: CC-Link is a high-speed field network able to simultaneously handle both control and information data.
- When connected to an optional AD-8526 Ethernet converter, it can convert the AD-4212C RS-232C data, for output to a local area network (LAN).

Example 1 (Connecting to a personal computer or an AD-8922A)

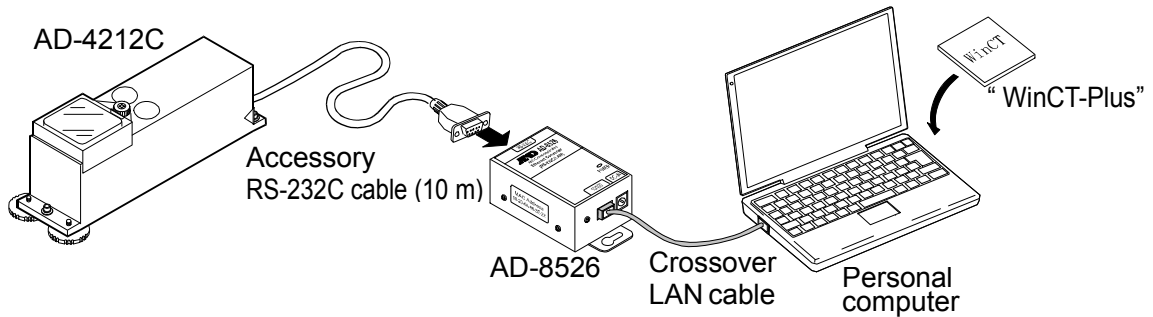
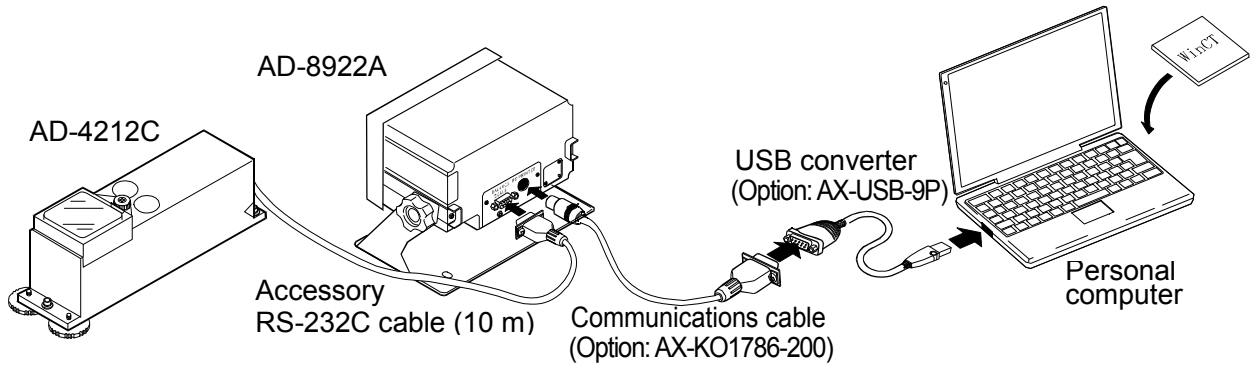
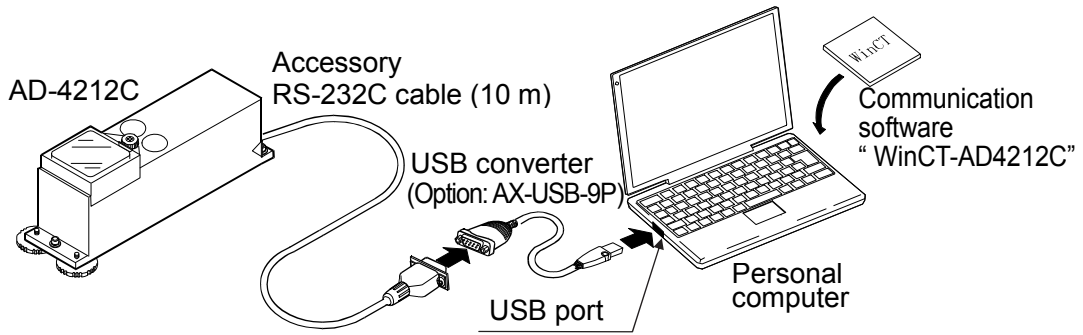

Example 2 (Connecting to a PLC)

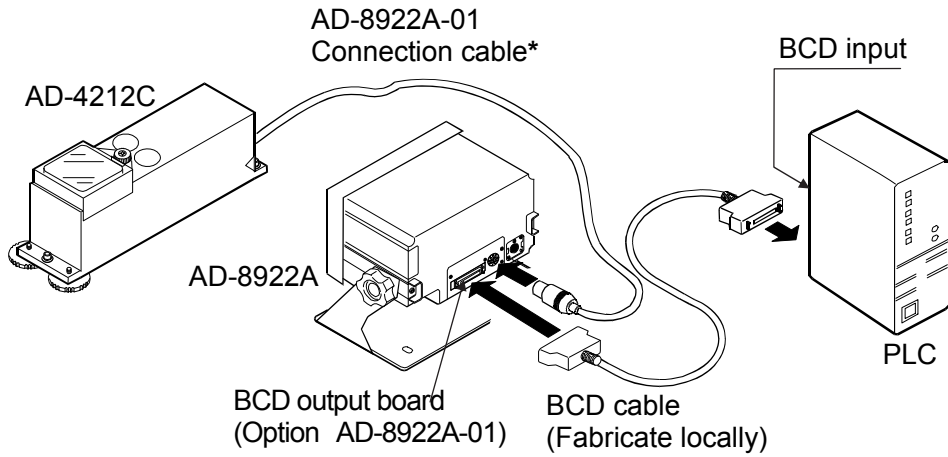
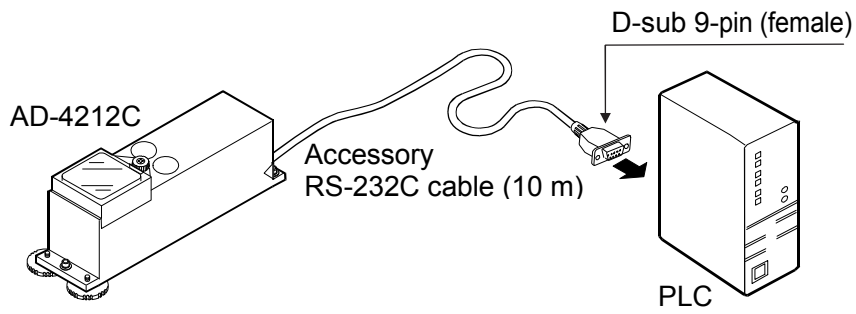

* Specify the AD-8922A-01 connection cable when ordering the AD-8922A-01.

AX-KO3705-200	2 m
AX-KO3705-500	5 m
AX-KO3705-1000	10 m

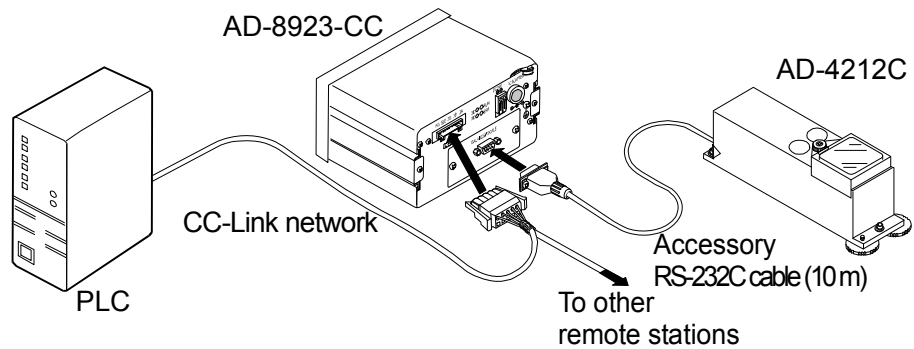

1.2. Compliance

Compliance with FCC Rules

Please note that this equipment generates, uses and can radiate radio frequency energy. This equipment has been tested and has been found to comply with the limits of a Class A computing device pursuant to Subpart J of Part 15 of FCC rules. These rules are designed to provide reasonable protection against interference when the equipment is operated in a commercial environment. If this unit is operated in a residential area, it may cause some interference and under these circumstances the user would be required to take, at his own expense, whatever measures are necessary to eliminate the interference.

(FCC = Federal Communications Commission in the U.S.A.)

Compliance with EMC Directives

CE This device features radio interference suppression, safety regulation and restriction of Hazardous Substances in compliance with the following Council Directives

Council directive 2014/30/EU	EN61326	EMC directive
Council directive 2014/35/EU	EN60950	Safety of Information Technology Equipment
Council directive 2011/65/EU	EN50581	Restriction of the use of certain Hazardous Substances

- The CE mark is an official mandatory European marking.
Please note that any electronic product must comply with local laws and regulations when sold or used anywhere outside Europe.



A & D Instruments Ltd. hereby declare that the following Weighing product conforms to the requirements of the council directives on ...

**Electromagnetic Compatibility (EMC) 2014/30/EU,
Low Voltage Equipment (LVD) 2014/35/EU and
Restriction of the use of certain Hazardous Substances (RoHS) 2011/65/EU**

provided that they bear the CE mark of conformity.

Model/Series....AD-4212C Series

Standards applicable:

EN 61326-1:2013

Electrical equipment for measurement, control and laboratory use -EMC requirements Part 1: General requirements

EN 60950-1:2006+A11:2009+A1:2010.A11:2012

Safety of Information Technology Equipment

EN 50581:2012

Technical documentation for the assessment of electrical and electronic products with respect to the restriction of hazardous substances

CE Mark first applied 16 August 2009

Signed for A&D Instruments in Oxford England 01 July 2016



J. Ghuman
Managing Director

2. UNPACKING THE BALANCE

2.1. Unpacking

- The balance is a precision instrument. Unpack the balance carefully. Keep the packing material to be used for transporting the balance in the future.
- When unpacking, see the illustration below to confirm that everything is included.

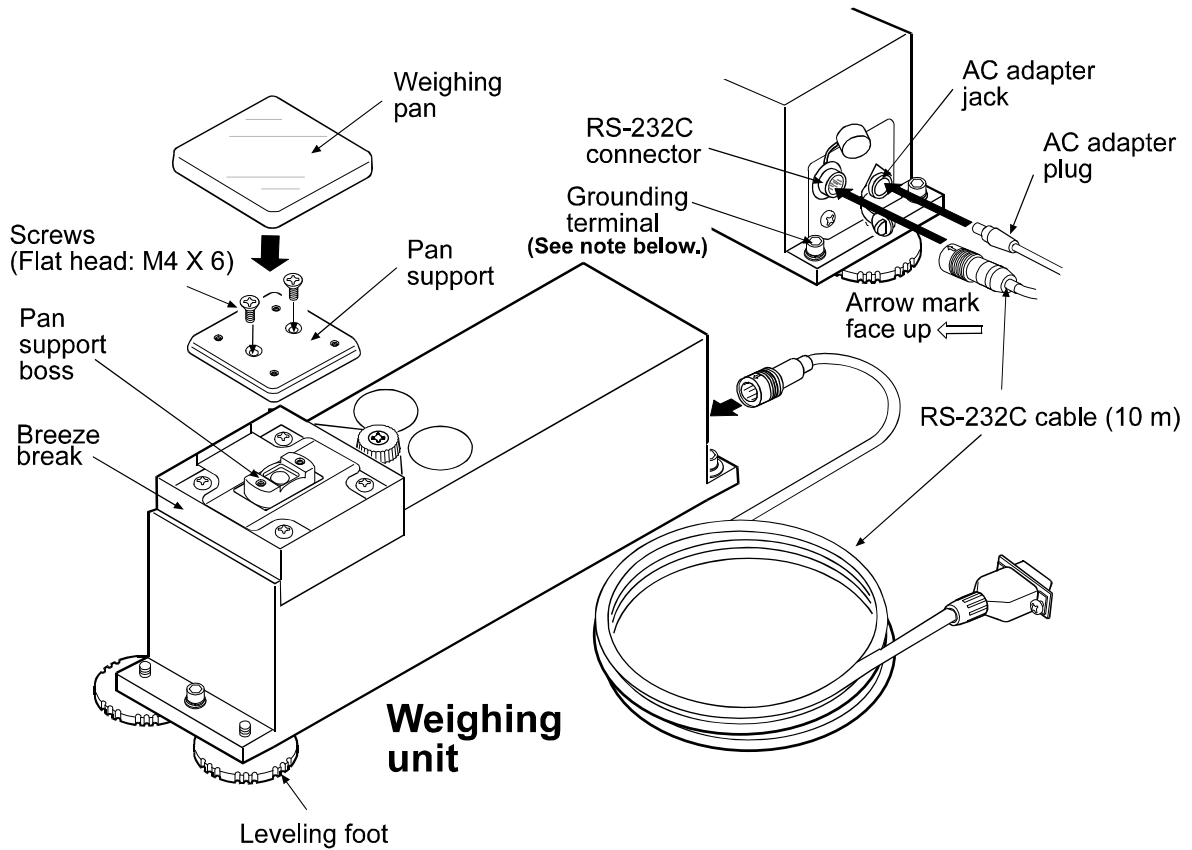

Accessories

Windows communication tools (WinCT-AD4212C)



- RS-232C cable (10 m)^{*2}
- Weighing pan
- Pan support
- Screws (Flat head: M4 X 6)

AC adapter^{*1}

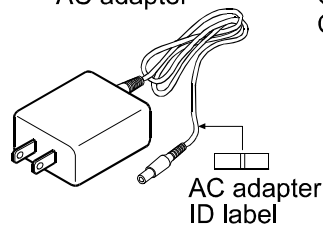

Calibration weight 200 g
OIML, Class E2 or equivalent

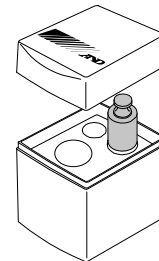

^{*1} Please confirm that the AD adapter type is correct for your local voltage and receptacle type.

^{*2} 2-m and 5-m cables are available as options. Refer to "11. OPTIONS".

Note

- When the AD-4212C series weighing unit is built into a system, be sure to earth ground the weighing unit using the grounding terminal.

ATTACHING THE AD-4212C SERIES WEIGHING UNIT DIRECTLY ON THE MOUNTING BASE

When the AD-4212C series weighing unit is built into a system, remove the three leveling feet and use the screw holes to secure the weighing unit to the base.

Attachment Procedure

1. Remove the three leveling feet.

Caution

Do not remove any other screws from the bottom of the weighing unit. Doing so could damage the weighing sensor.

2. Secure the weighing unit from above. (Prepare appropriate screws with a size corresponding to an M5 screw. The screw hole diameter: 6 mm).

In case of securing the weighing unit from the under side, use M6 screws with 1-mm pitch.

Notes

- **The screws to secure the weighing unit to the mounting base are not provided.**
- **For the position of the holes, refer to “10. EXTERNAL DIMENSIONS”.**

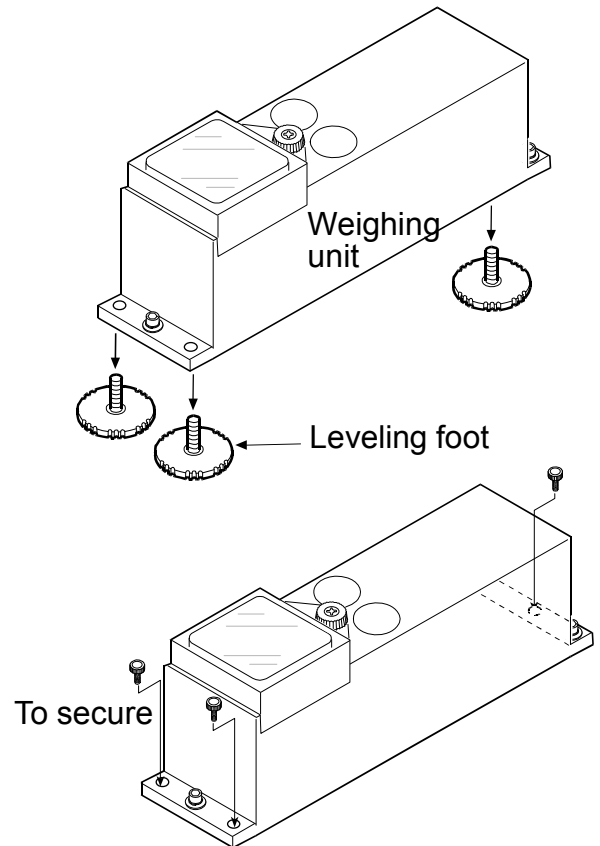

When the leveling adjustment is difficult to perform due to the installation conditions, place a shim between the lower surface of the weighing unit and the securing surface, or use two nuts. If the adjustment is still difficult to perform, perform calibration before use. Then, the balance will function normally.

2.2. Installing the Balance

Install the balance as follows:

1. Refer to "3. PRECAUTIONS" for installing the balance.
2. Refer to "2.1. Unpacking" on page 8, to attach the pan support and the weighing pan on the weighing unit.
3. Insert the RS-232C cable into the jack located on the rear of the weighing unit.

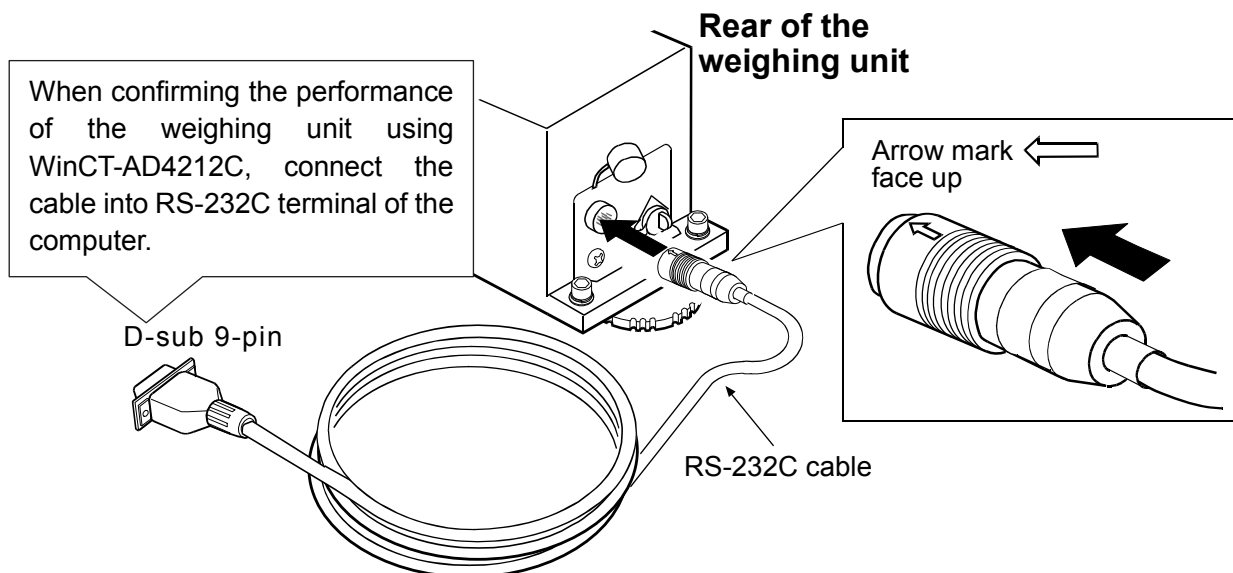

How to disconnect the cable from the weighing unit

Slide the connector sleeve in the direction of the arrow to unlock and gently pull the connector out.

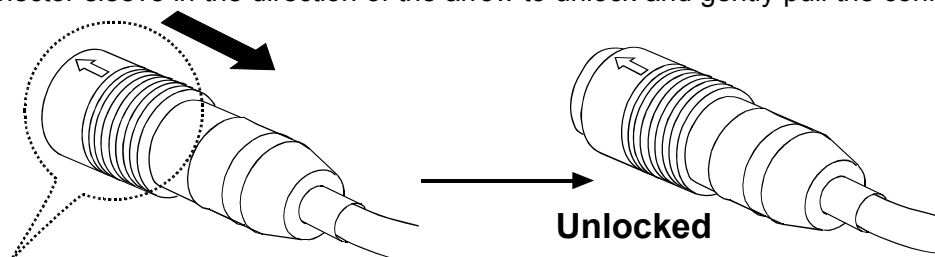

Slide the connector sleeve in the direction of the arrow

4. Confirm that the AC adapter type is correct for the local voltage and power receptacle type.
5. Plug the AC adapter plug into the AC adapter jack located on the rear of the weighing unit and plug the AC adapter into the electrical outlet. Warm up the balance for 30 minutes or more with nothing on the weighing pan.
6. Set the pan unit and I/O unit to adapt to the peripheral system. Set the following for the I/O unit.
 - RS-232C (Refer to "6. COMMUNICATION SPECIFICATIONS")Set the weighing speed to adapt to the ambient conditions.

Note

- **Make sure that the personal computer is in operation before connecting to the AD-4212C.**
7. After the balance has been installed, calibrate the balance using the 200 g calibration weight provided with the balance. For details, refer to "4.2. Calibration".
(The AD-4212C-3000/6000/3100 can be calibrated using the 200 g weight.)
 8. By removing the provided weighing pan, a locally fabricated weighing pan can be attached to the AD-4212C series by using the four screw holes (M4 screw x pitch 0.7 mm) on the pan support.

MASS OF THE LOCALLY FABRICATED WEIGHING PAN

Design the weighing pan so that the mass falls within the ranges shown in the table below:

Model	Status	Mass of the weighing pan (g)
AD-4212C-300/301	Pan support is used (with weighing pan removed)	20 to 130
	Pan support boss is used (with the weighing pan and pan support removed)	70 to 180
AD-4212C-600	Pan support is used (with weighing pan removed)	20 to 410
	Pan support boss is used (with the weighing pan and pan support removed)	70 to 460
AD-4212C-3000/3100	Pan support is used (with weighing pan removed)	20 to 3010
	Pan support boss is used (with the weighing pan and pan support removed)	70 to 3060
AD-4212C-6000	Pan support is used (with weighing pan removed)	20 to 6010
	Pan support boss is used (with the weighing pan and pan support removed)	70 to 6060

AD-4212C-300/301

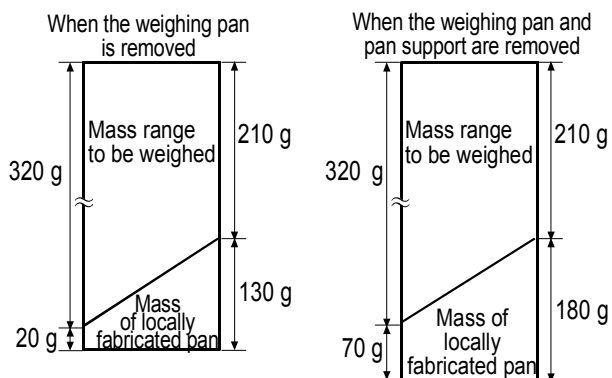

AD-4212C-600

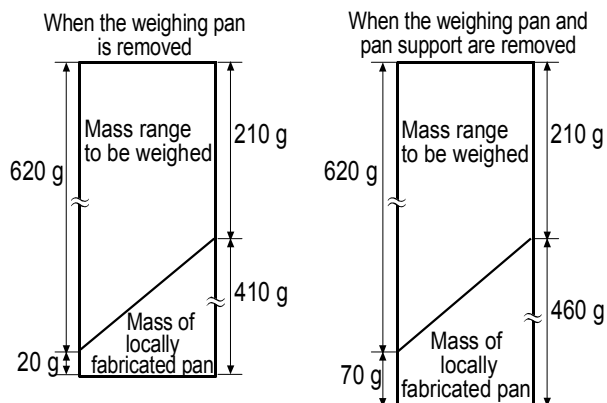

AD-4212C-3000/3100

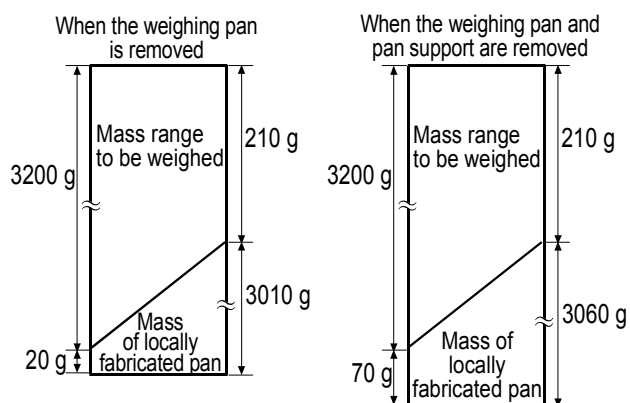

AD-4212C-6000

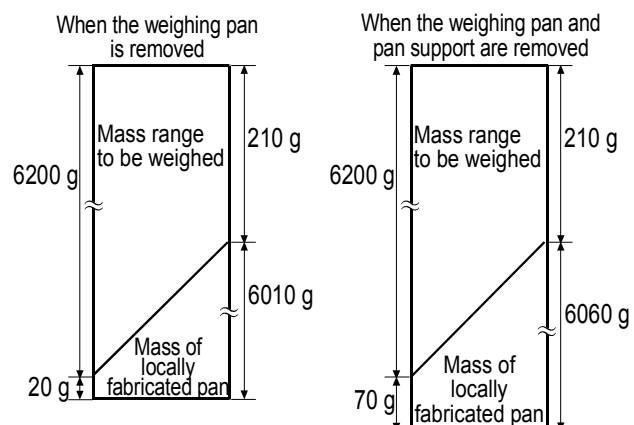

Notes

- If the balance is to be used in a range other than shown above, contact the local A&D dealer.
- To avoid the effects of static electricity or magnetism, use materials other than resin or magnetic materials when designing a weighing pan.
- When a locally fabricated weighing pan is used, the zero point may be shifted greatly right after the AC adapter is plugged in. Perform re-zero before weighing to cancel the amount of zero drift as necessary.

3. PRECAUTIONS

To get the optimum performance from the balance and acquire accurate weighing data, note the following:

3.1. Before Use

- Install the weighing unit in an environment where the temperature and humidity are not excessive. The best operating temperature is about 20°C / 68°F at about 50% relative humidity.
- Install the weighing unit where it is not exposed to direct sunlight and it is not affected by heaters or air conditioners.
- Install the weighing unit where it is free of dust.
- Install the weighing unit away from equipment which produces magnetic fields.
- Install the weighing unit in a stable place avoiding vibration and shock. Corners of rooms on the first floor are best, as they are less prone to vibration.
- Ensure a stable power source when using the AC adapter.
- Plug in the AC adapter as usual, and warm up the balance for 30 minutes or more.
- Calibrate the balance before use or after having moved it to another location.

In addition, calibrate it periodically to maintain the accuracy.

Caution

Do not install the balance where flammable or corrosive gas is present.

3.2. When Building Into a System

The AD-4212C is a precision balance. When it is built into a system, errors such as unstable weight values may occur due to static electricity, vibration, sample temperature and magnetism of the materials weighed or used for the devices near the balance.

When using the balance as part of a system, take the following precautions:

● Precautions when not performing the weighing at the center of the weighing pan

If not performing the weighing at the center of the weighing pan, design the weighing system so that the total moment of the support device and the object to be weighed will be the value specified in the table below. Even a load, with a moment of less than the specified value, when applied to the balance, may cause the overload protection mechanism to function slowly, to tilt the weighing pan.

Allowable eccentric load for each model

Model	Allowable eccentric load
AD-4212C-300/600/301	0.1 Nm or less
AD-4212C-3000/6000/3100	0.3 Nm or less

AD-4212C-300/600/301

Example of a system where the total moment of the device and the object is 0.1 Nm or less:

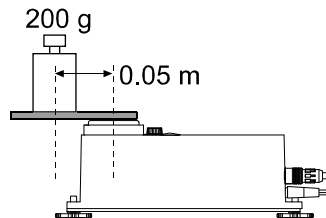

$$200 \text{ g} \times 0.05 \text{ m}$$

AD-4212C-3000/6000/3100

Example of a system where the total moment of the device and the object is 0.3 Nm or less:

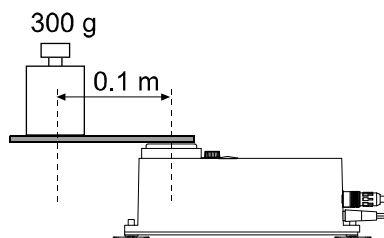

$$300 \text{ g} \times 0.1 \text{ m}$$

Note: The values above are for reference and may be different from actual specifications.

Although the overload protection mechanism is built in, please avoid giving impact shock to the weighing pan while weighing.

● **Errors due to a static charge and measures to take**

When the ambient humidity is less than 45% RH, insulators such as plastic or glass are prone to static electricity. When charged material comes close to the balance, a pulling force is generated by static induction between the charged material and the weighing pan. This causes an unstable weight value.

To protect the balance against a discharge generated by charged material when it comes close to the balance, be sure to earth ground the weighing unit and the display unit.

Note that static electricity generated by static induction will not be canceled by earth-grounding. Use a humidifier or the AD-1683 DC static eliminator,

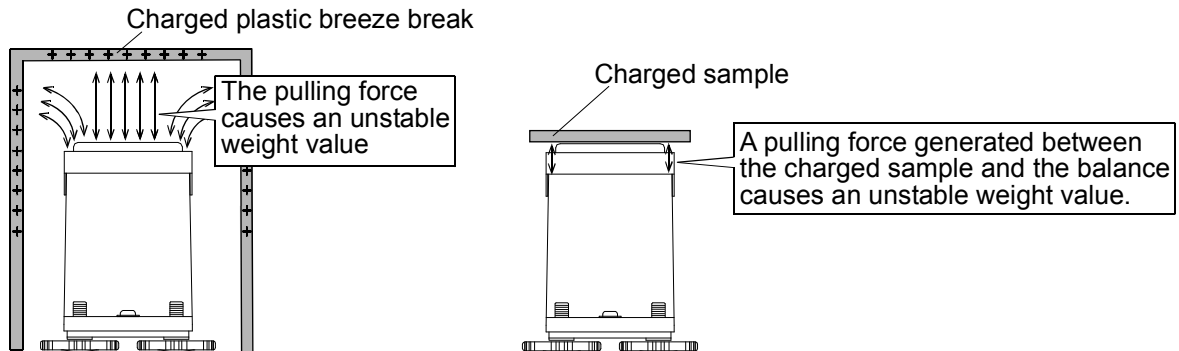

Measures to take (Plastic is used in the examples below. They can be applied to glass, too.)

- When the sample or devices are plastic
 - Use a static eliminator that generates no air blow such as the AD-1683, DC static eliminator, to remove static electricity.
 - Place the sample in a container that is made of a conductive material such as metal and that can be sealed, and then weigh it.
- When the sample is powdery
 - When the balance is used in combination with a feeder for batch weighing of powdery samples, samples may be charged by rubbing sample particles against each other. Use a static eliminator and perform weighing while removing static electricity.
- When the sample container is made of material that is prone to static electricity such as plastic
 - Cover the outside of the container with a metal such as aluminum foil.
 - Apply an anti-static agent onto the container.
- When making a breeze break using plastic
 - Apply an anti-static agent onto the breeze break.
 - Use a conductive acrylic fiber.
- When plastic exists in the balance installation site
 - Cover the plastic with a grounded conductive material.
 - Apply an anti-static agent onto the plastic.
- When an operator is static charged

If an operator's clothes are static charged, especially in winter, it may be a cause for unstable weight values.

 - Wear an anti-static wrist strap.

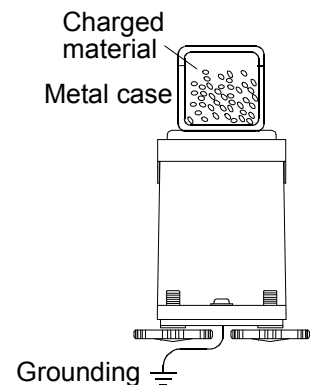

● Errors due to airflow and measures to take

- Where the influence of ambient airflow is great such as: close to an air conditioner, door or passage way. Even very subtle airflow that is hard to be detected may influence the weighing operation.
 - Avoid those areas as a weighing site.
 - If weighing is to be performed in such an area, use a breeze break or take other appropriate measures.

- Where the influence of heat or drafts is great
 - Eliminate temperature differences between a sample and the environment. When a sample is warmer (cooler) than the ambient temperature, the sample will be lighter (heavier) than the true weight. This error is due to a rising (falling) draft around the sample.
 - Do not touch the sample directly with your hand. Use tweezers or other tools. If you touch the sample, the same type error described above will occur.
 - Do not perform weighing where it is exposed to direct sunlight. Weighing errors may occur due to sudden temperature change or drafts.

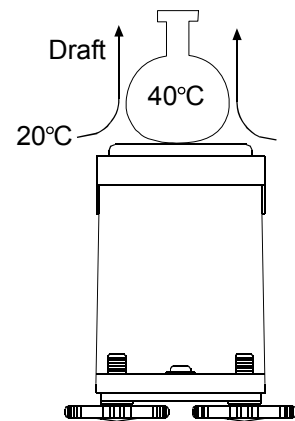

● Errors due to vibration and measures to take

- Where the influence of vibration is great, such as:
 - (1) Soft ground (2) Second or higher floor (3) Near center of a floor far from pillars (4) Seismic isolated structures (5) Near tall buildings.In the areas listed above, the scale may yield unstable weight values on windy days or after an earthquake. Especially in case of (4) and (5), weight values may be unstable for a long period of time because of long lasting low-frequency vibration after strong winds or an earthquake.

● Errors due to other causes and measures to take

- Change in temperature or humidity

A sudden change in temperature or humidity can generate a draft and cause the balance to absorb or exude moisture, which leads to unstable displays.

 - Avoid sudden change in temperature or humidity.
 - Use an air conditioner or humidifier to control the temperature or humidity.
- Magnetic material

The balance uses a strong magnet as part of the balance assembly, so use much care when weighing magnetic materials.

 - Place a non-magnetic object such as aluminum or brass between the sample and the balance to keep an appropriate distance between them while weighing.

3.3. During Use

- To minimize the affect by electrical noises, earth ground the weighing unit and the display unit (option).
- Do not drop things upon the weighing pan, or place a sample on the pan that is beyond the balance weighing capacity. Place a sample in the center of the weighing pan to minimize corner-load errors.
- To prevent possible errors, before each weighing, perform re-zero using the RS-232C command, or calculate the difference between the weight value before and after weighing.
- Take into consideration the affect of air buoyancy on a sample when measuring the absolute value with the minimum weighing value of 0.1 mg.
- Even though the scale is dust-protected and protected against splashing water, complying with IP65, be sure to clean the weighing pan and keep the conditions around the pan clean after weighing powdery, fluid samples or metallic strips.

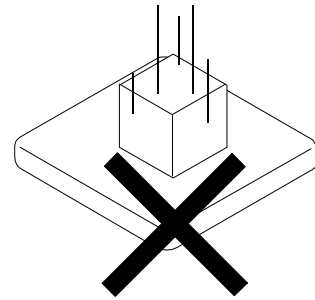

3.4. After Use

- Avoid mechanical shock to the weighing unit.
- Periodically calibrate the balance, using a calibration weight.
- Do not disassemble the weighing unit. Contact the local A&D dealer if the balance needs service or repair.
- Do not use organic solvents to clean the weighing unit. Clean the weighing unit with a lint free cloth that is moistened with warm water and a mild detergent.
- Avoid dust and water so that the weighing unit weighs correctly. Protect the internal parts from liquid spills and excessive dust.

3.5. Power Supply

- When the AC adapter is connected, the balance is in the standby mode if the standby indicator is on (refer to “4. OPERATION OF WinCT-AD4212C”). This is a normal state and does not harm the balance. For accurate weighing, plug in the AC adapter and warm up the balance for the appropriate duration before use.

4. OPERATION OF WinCT-AD4212C

The software has the following functions:

- Set the weighing speed
- Set the minimum display value
- Calibration
- Set the baud rate
 - The parameters set using these functions, are stored in non-volatile memory, and maintained, even if the AC adapter is removed.
- A data logging function, allows confirmation of the weighing data after weighing

Before use

1. Install the WinCT-AD4212C into the computer. For details, refer to Readme of WinCT-AD4212C.
2. Connect one end of the RS-232C cable to the weighing unit RS-232C connector and connect the other end of the RS-232C cable (D-sub 9-pin) to the personal computer RS-232C terminal.
3. Set the COM port of the WinCT-AD4212C on the personal computer, and press the **START** button. The personal computer will display the weight value.

Function of display symbols and buttons

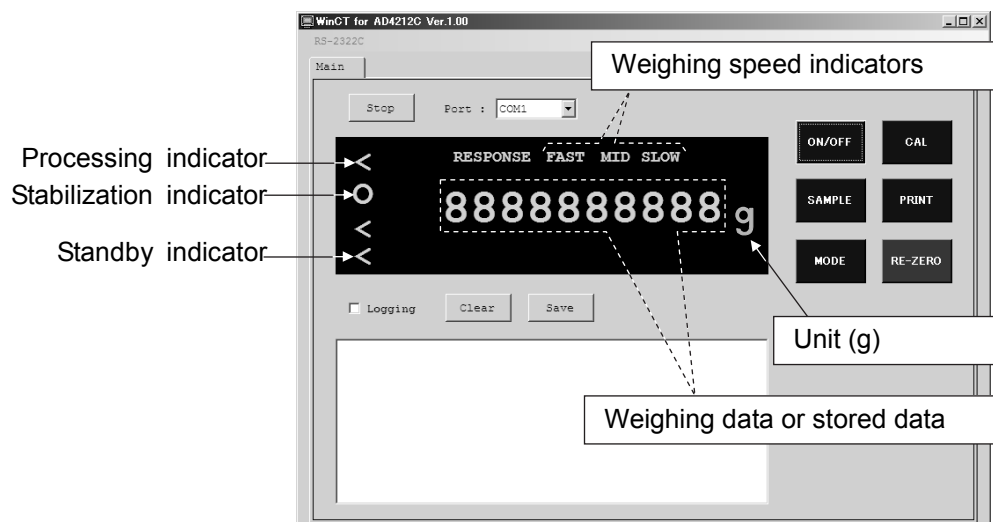

Button	When pressed
ON/OFF	Switches between the weighing mode and the standby mode. With the standby mode, only the standby indicator is displayed. The ON/OFF button is available anytime. Therefore, if you press the ON/OFF button when operating, the balance switches to the standby mode.
SAMPLE	In the weighing mode, switches the minimum weighing value.
MODE	Changes the weighing speed.
CAL	Enters the calibration mode.
PRINT	(Usually no function. Used in the calibration mode.)
RE-ZERO	Sets the display to zero.

4.1. Changing the Weighing Speed Using WinCT-AD4212C

The weighing speed can be selected from the following three rates to minimize the influence on weighing that is caused by drafts and/or vibration at the place where the balance is installed.

Indicator	Speed	Stability
FAST	Fast	Sensitive value
MID.	↑	↓
SLOW	Slow	Stable value



Operation

1. Press the **MODE** button.

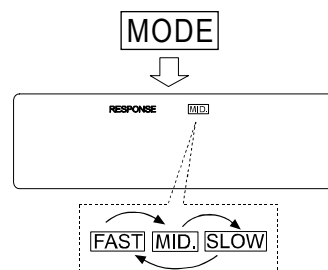

2. Press the **MODE** button to select a weighing speed. Either **FAST**, **MID.** or **SLOW** can be selected.

MODE Each pressing switches the indicators

4.2. Calibration

Calibration

Calibration using the calibration weight.

Caution

- Do not allow vibration or drafts to affect the balance during calibration.

Caution on using an external calibration weight

- The accuracy of the weight can influence the accuracy of weighing. Select an appropriate weight as listed below. A calibration weight (conforming to OIML, Class E2 or equivalent) is provided with the balance as a standard accessory.

Model	Usable calibration weight	Calibration weight provided
AD-4212C-300	50g, 100g, 200 g , 300g	200 g
AD-4212C-600	50g, 100g, 200 g , 300g, 400 g, 500 g, 600 g	
AD-4212C-3000	50g, 100g, 200 g , 300g, 500 g, 1000 g, 2000g, 3000g	
AD-4212C-6000	200 g , 500 g, 1000 g, 2000g, 3000g, 4000 g, 5000 g, 6000 g	
AD-4212C-301	50g, 100g, 200 g , 300g	
AD-4212C-3100	50g, 100g, 200 g , 300g, 500 g, 1000 g, 2000g, 3000g	

The calibration weight in bold type: factory setting

Display



- This indicator means "the balance is measuring calibration data". Do not allow vibration or drafts to affect the balance while this indicator is displayed.

Calibration procedure

This function calibrates the balance using the calibration weight. (Display example: AD-4212C-300)

Operation

1. Plug in the AC adapter and warm up the balance for 30 minutes or more with nothing on the pan.

2. Press the **CAL** button. **CAL 0** is displayed.

- If you want to cancel calibration, press the **CAL** button. The balance will return to the weighing mode.
- If you want to change the calibration mass value, press the **SAMPLE** button. Press the **RE-ZERO** button to select the mass value, and press the **PRINT** button to store it. **CAL 0** is displayed.

3. Confirm that there is nothing on the pan and press the **PRINT** button. The balance measures the zero point. Do not allow vibration or drafts to affect the balance. The balance displays the calibration weight value.

4. Place a calibration weight, of the weight value displayed, on the pan and press the **PRINT** button. The balance measures the calibration weight. Do not allow vibration or drafts to affect the balance.

5. The balance displays **End**. Remove the weight from the pan.

6. The balance will automatically return to the weighing mode.

7. Place the calibration weight on the pan and confirm that calibration was performed correctly. If not, check the ambient conditions such as drafts or vibration, and repeat steps 2 through 7.

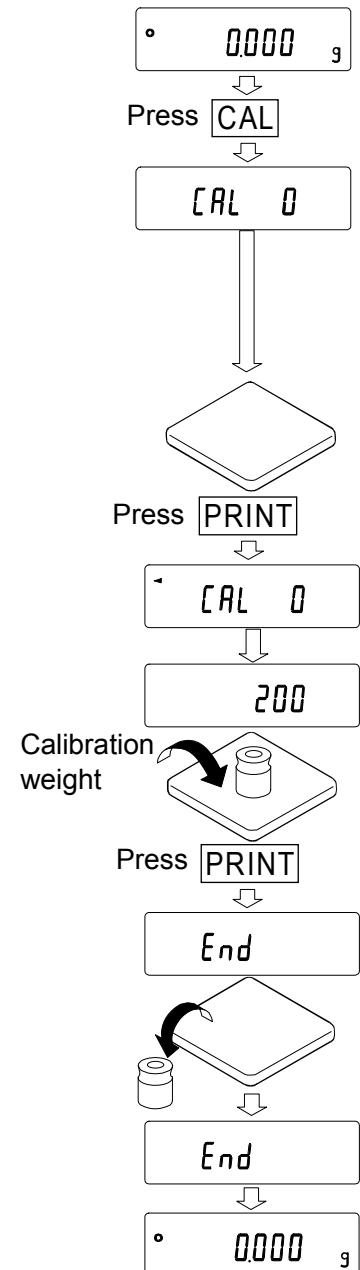

4.3. Changing the Baud Rate Using WinCT-AD4212C

Operation

- 1. Click the [Settings] tab.
- 2. Select the baud rate to be used and click the [Set] button. (Factory setting: 2400)

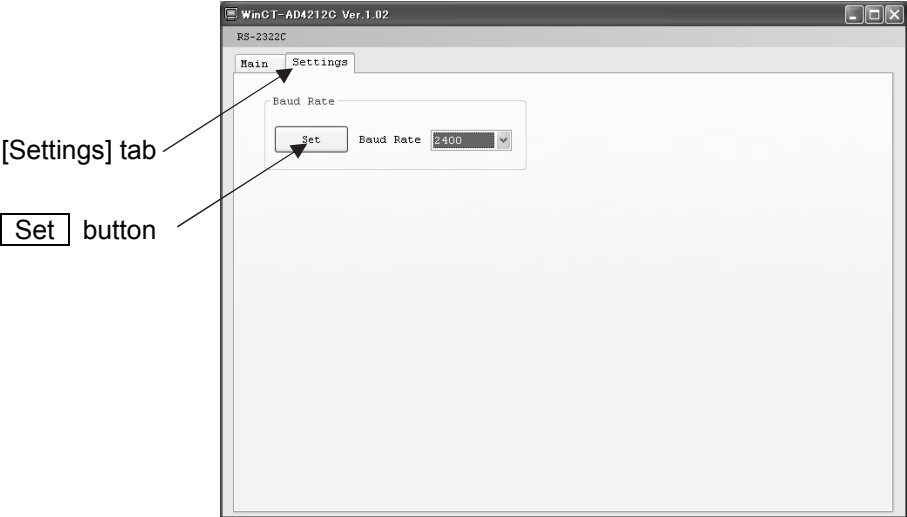

- 3. "Completed" appears when the setting is complete.

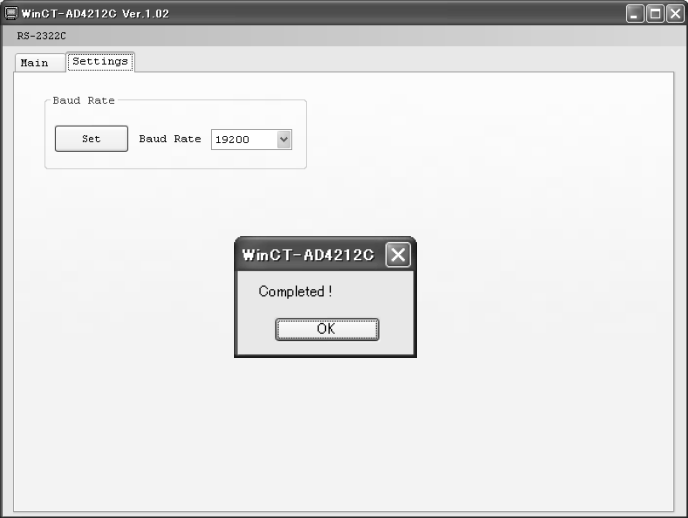

5. SMART RANGE FUNCTION

The AD-4212C-301/3100 are equipped with two ranges. The precision range has a higher resolution. The standard range has a normal resolution.

The range switches automatically, depending on the value displayed. Sending the R command allows weighing in the precision range, regardless of the tare value.

The range can be fixed to the standard range by changing the minimum weighing value using the SMP command.

Display example: AD-4212C-301

- 1 Send the R command
The balance will start weighing, using the precision range.
- 2 Place a container on the weighing pan.
The weight value exceeds the precision range value and the balance will switch to the standard range.
- 3 Send the R command
The balance will switch to the precision range.
- 4 Place a sample in the container.
The weight value is within the precision range value and the balance will perform a weighing, using the precision range.

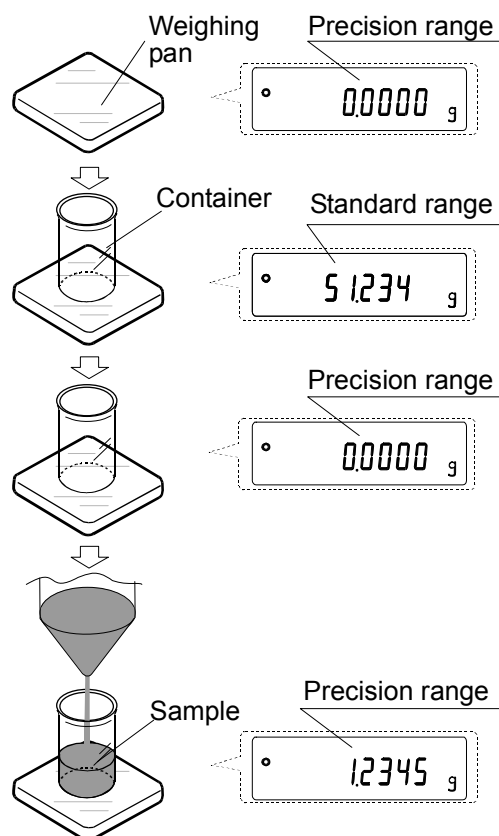

Precision range/standard range

Model	Range used	Weighing range	Available minimum weighing value
AD-4212C-301	Precision range ^{*1}	0 g to 51 g	0.0001 g
	Standard range	51 g to 320 g	0.001 g
AD-4212C-3100	Precision range ^{*2}	0 g to 510 g	0.001 g
	Standard range	510 g to 3200 g	0.01 g

- The factory setting is the precision range.

***1** When the weight value exceeds 51 g while the minimum weighing value of 0.0001 g (precision range) is used, the balance will switch to the minimum weighing value of 0.001 g (standard range). By sending the R command, the balance can weigh from that point up to 51 g, using the minimum weighing value of 0.0001 g (precision range).

***2** When the weight value exceeds 510 g while the minimum weighing value of 0.001 g (precision range) is used, the balance will switch to the minimum weighing value of 0.01 g (standard range). By sending the R command, the balance can weigh from that point up to 510 g, using the minimum weighing value of 0.001 g (precision range).

6. COMMUNICATION SPECIFICATIONS

The AD-4212C series can communicate interactively using RS-232C.

The AD-4212C series can continuously transmit the weighing data. (Approx.10 times/second* to 50 times/second)

The AD-4212C series is DCE. The AD-4212C series can connect directly to the RS-232C terminal of a personal computer by using the accessory RS-232C cable.

* Factory setting

1. RS-232C specification

Transmission system	EIA RS-232C	
Transmission form	Asynchronous, bi-directional, half duplex	
Transmission rate	Approx.10 times/second* to 50 times/second	
Data format	Baud rate	2400bps* to 19200bps
	Data bits	7 bits
	Parity	EVEN
	Stop bit	1 bits
	Code	ASCII
	Terminator	<CR><LF>

* Factory setting

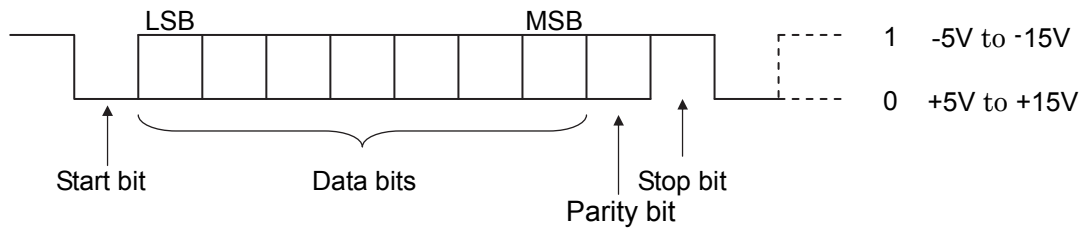

Relation between baud rate and transmission rate of weighing data

Baud rate	Transmission rate of weighing data
2400bps	12.5 times/second
4800bps	25.0 times/second
9600bps	50.0 times/second
19200bps	50.0 times/second

2. Pin position

Pin position of the RS-232C cable (D-Sub 9-pin side, female)

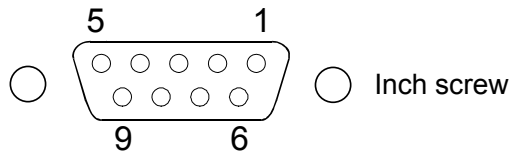

Pin No.	Signal name	Direction	Description
1	(Vs)	-	Internally used* (Power supply GND terminal for external equipment)
2	TXD	Output	Transmit data
3	RXD	Input	Receive data
4	-	-	N.C.
5	SG	-	Signal ground
6	-	-	Internally used*
7	RTS	Input	Request to send
8	CTS	Output	Permission to send
9	(Va)	-	Internally used* (Power supply output terminal for external equipment)

CTS and RTS are internally connected in the balance.

The AD-4212C can communicate by connecting TXD, RXD and SG.

* When connecting to a PLC such as the external equipment, do not connect to the internally used signal line.

3. Data output format

- This format consists of fifteen characters excluding the terminator<CR><LF>.
- A header of two characters indicates the balance condition.
- The polarity sign is placed before the data with the leading zeros. If the data is zero, the plus sign is applied.

Example of output

1	2	3	4	5	6	7	8	9	10	11	12	13	14	15
S	T	,	+	0	0	1	2	.	3	4	5			g
Header			Data									Unit		

When stable

S	T	,	+	0	0	1	2	.	3	4	5			g
---	---	---	---	---	---	---	---	---	---	---	---	--	--	---

When unstable

U	S	,	+	0	0	0	5	.	4	3	2			g
---	---	---	---	---	---	---	---	---	---	---	---	--	--	---

When over state (plus over)

O	L	,	+	9	9	9	9	9	9	9	E	+	1	9
---	---	---	---	---	---	---	---	---	---	---	---	---	---	---

When over state (minus over)

O	L	,	-	9	9	9	9	9	9	9	E	+	1	9
---	---	---	---	---	---	---	---	---	---	---	---	---	---	---

4. Command

The balance can be controlled by the following commands.

When transmitting, add the terminator <CR><LF> to each command.

Commands to query weighing data

When the display is turned on, the AD-4212C series outputs the weighing data continuously.

To use the Q or S command, send the C command to stop the continuous data output, then request the weighing data using the Q or S command.

Command	Description
C	Cancels the SIR command.
Q	Requests the weighing data immediately. (Outputs data regardless of the display condition, stable or unstable. Use this command while the continuous output is stopped.)
S	Requests the weighing data when stabilized. (After the weighing data has stabilized, outputs the data. Use this command while the continuous output is stopped.)
SIR	Requests the weighing data continuously. Starts the continuous output of the weighing data. (The C command stops the continuous output.)

Commands to control the balance

Command	Description
CAL	Enters the calibration mode. *1
OFF	Turns the display off. The weighing unit is in the standby mode.
ON	Turns the display on. The weighing unit is in the weighing mode.
P	Switches between the weighing mode and the standby mode.
PRT	Confirms the calibration value.
R	Sets the display to zero (tare). *2
SMP	Changes the minimum display.
U	Changes the weighing speed. *1

*1 When changing the weighing speed or in the calibration mode, the balance outputs the control character starting with “@”.

*2 When setting the display to zero, the command waits for the weight value to become stable. When the command waits for the weight value to become stable, the balance stops sending the weighing data.

Example of the R command

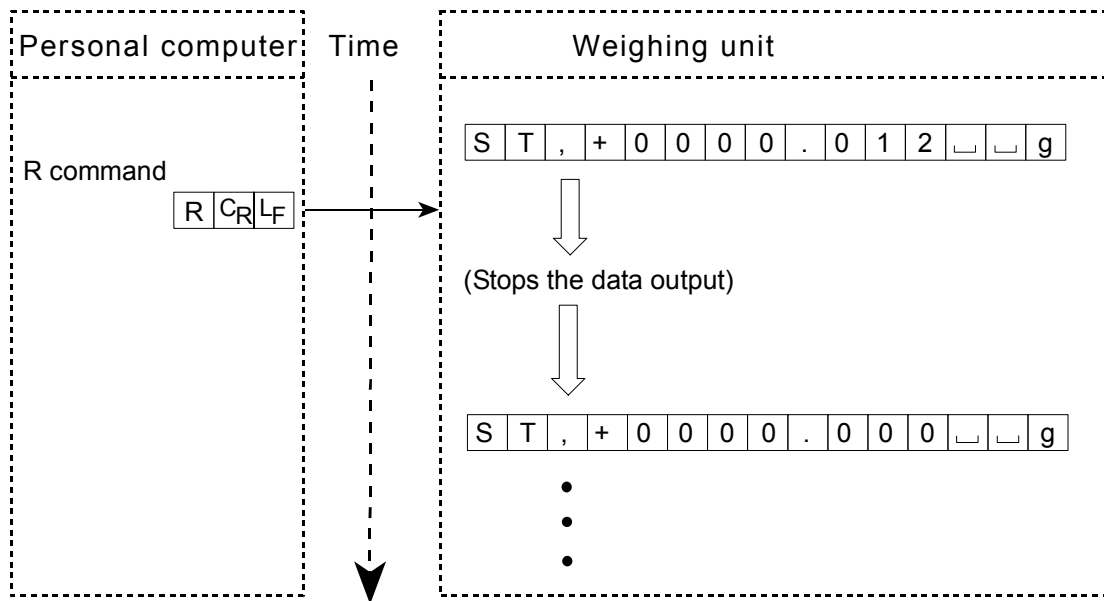

Example of the CAL command

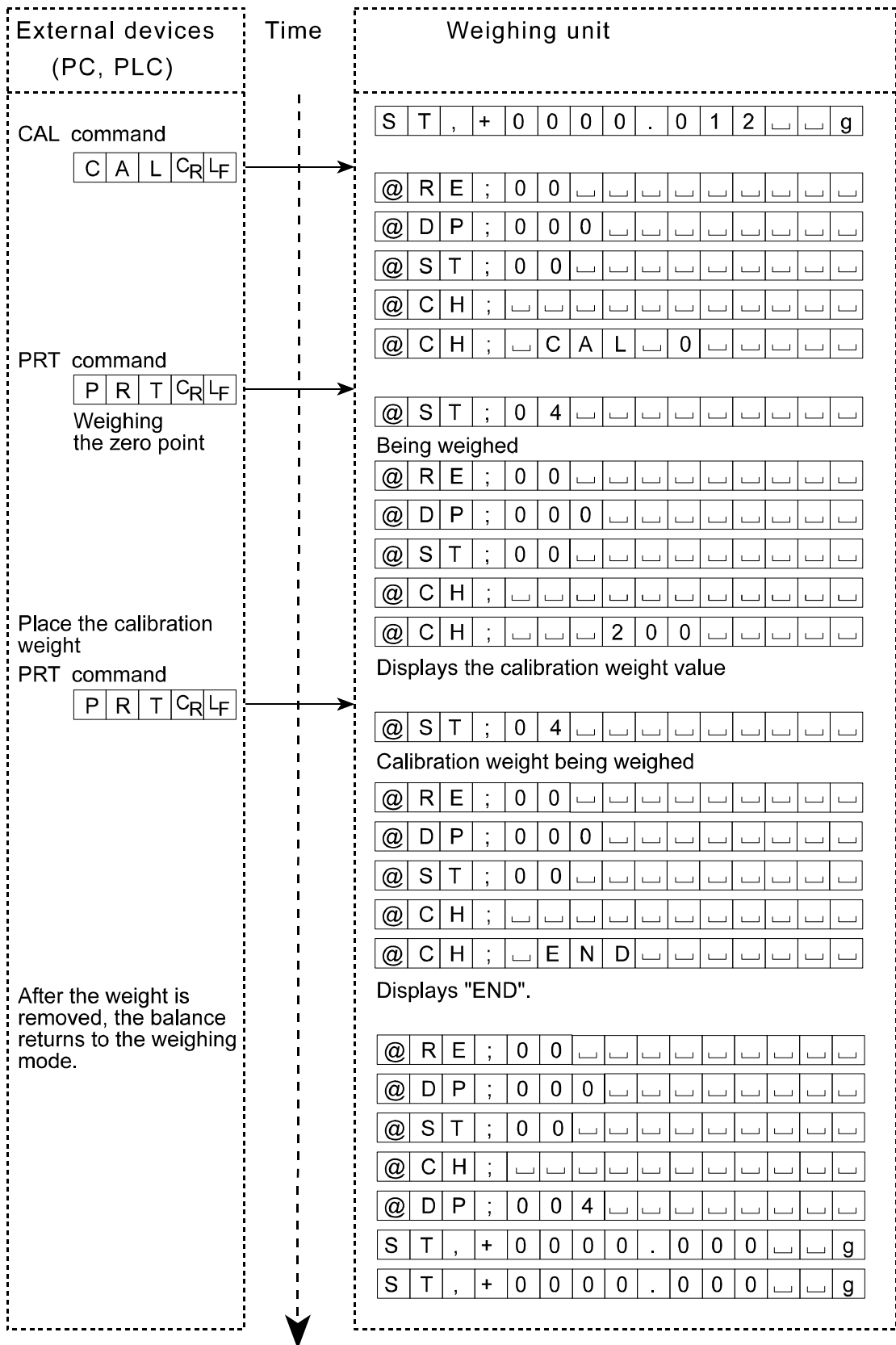

Example of the SMP command

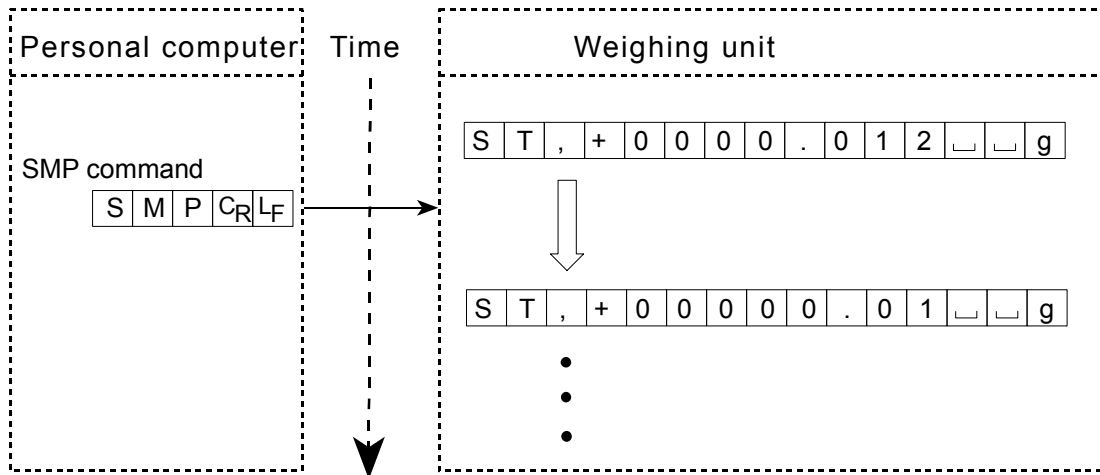

Example of the R command when the precision range is used

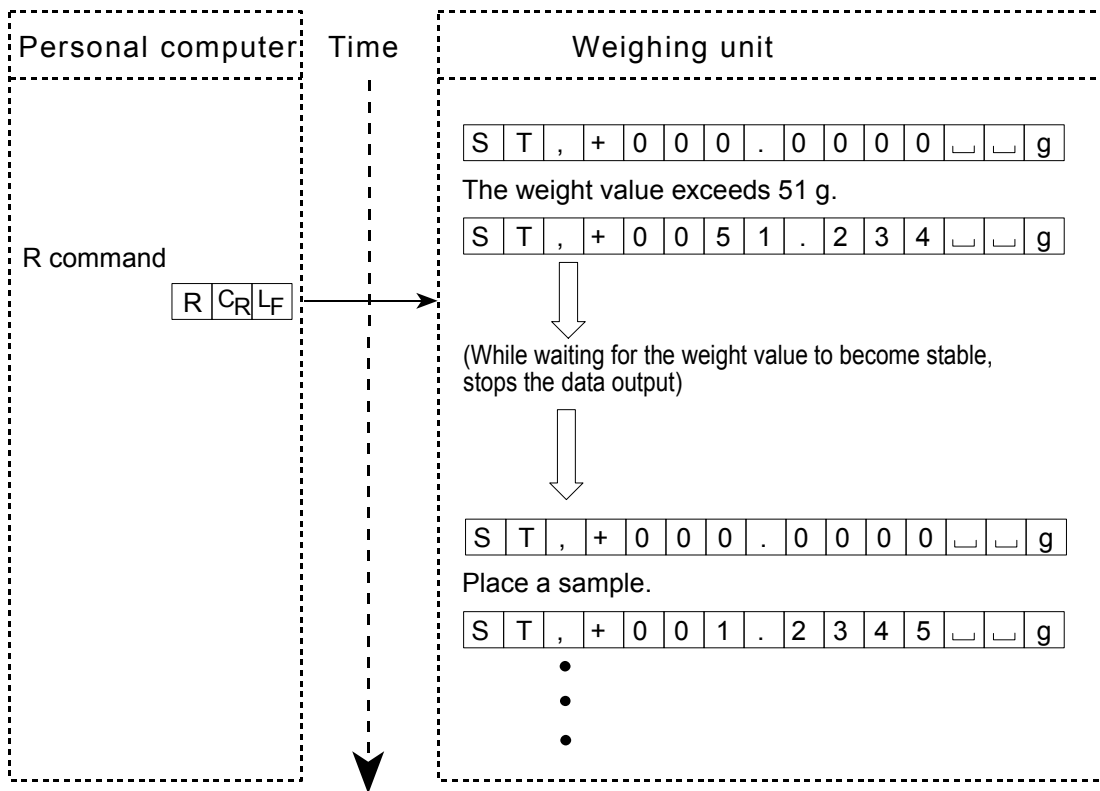

S command when old versions of the AD-4212C series balances are used

For AD-4212C balances with a software version 1.40 or earlier, the S command must be enabled using the procedure described below.

For AD-4212C balances with a software version 1.41 or later, the S command is enabled by sending the C command to stop the continuous data output.

Enabling the S command

Download the “WinCT” software on our website, <http://www.aandd.co.jp/>.

Carry out the following procedure using the “RsCom” software in the “WinCT”.

1. Send the C command to stop the continuous data output.

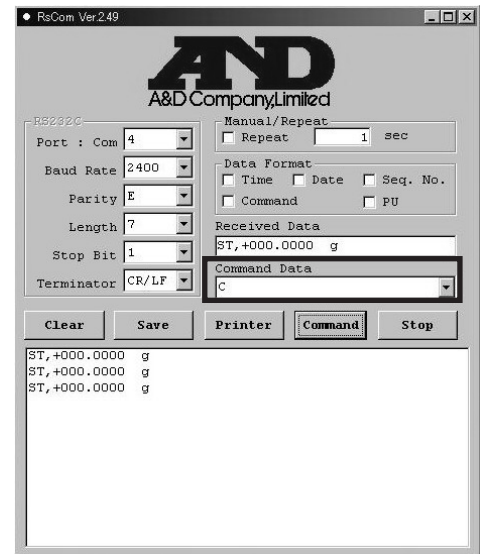

2. Changing the setting
Send the PR:00 command to the balance.
The balance enters the command mode. This enables the S command. This setting is maintained in memory even if the AC adapter is removed.

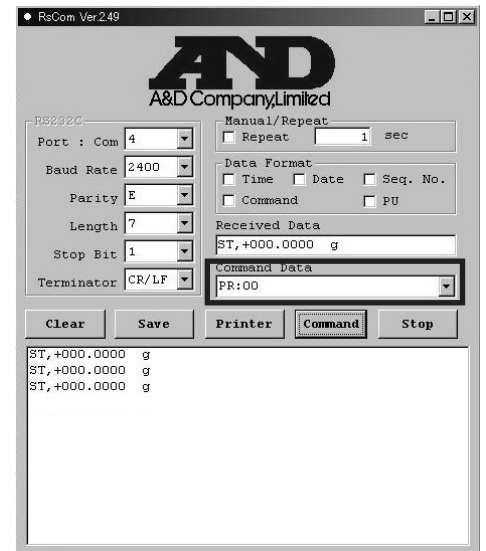

3. Confirming whether the PR:00 command has been carried out correctly.
Send the “?PRT” command.
When the response is “Pr,00”, the setting is correct.
Because the setting is in the command mode, the balance does not output the weighing data continuously.

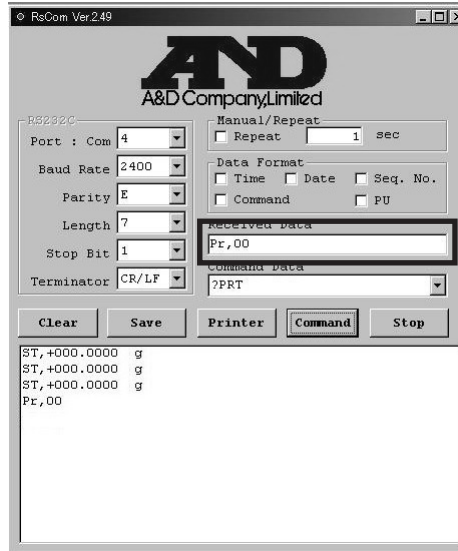

4. Returning the setting value to the default value
Send the “PR:03” command to the balance.
The balance enters the continuous output mode.
When the “SIR” command is sent to the balance, the balance outputs the weighing data continuously.

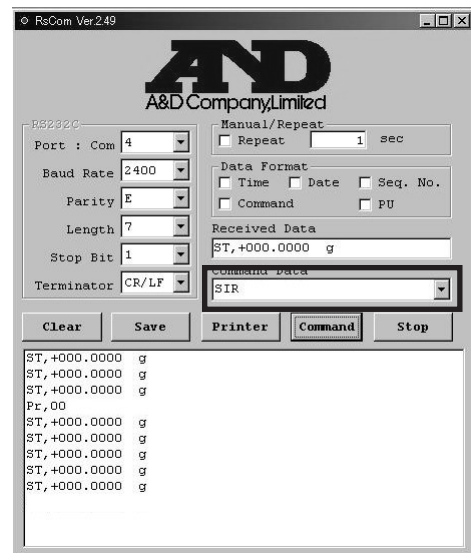
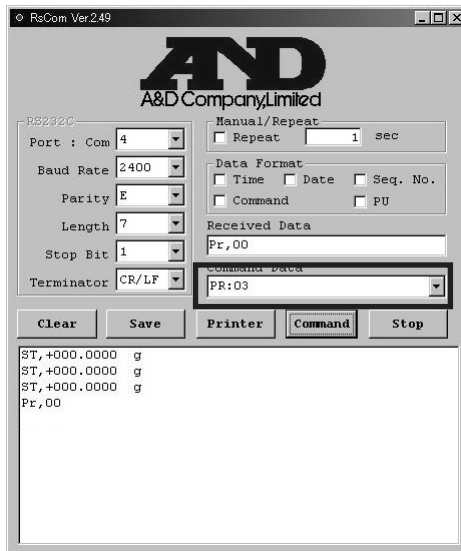

7. MAINTENANCE

- Do not disassemble the balance. Contact the local A&D dealer if the balance needs service or repair.
- Use the original packing material for transportation.
- Do not use organic solvents to clean the balance. Clean the balance with a lint free cloth that is moistened with warm water and a mild detergent.

8. TROUBLESHOOTING

8.1. Checking the Balance Performance and Environment

The balance is a precision instrument. When the operating environment or the operating method is inadequate, performing accurate weighing will not be possible. If the balance seems to have a problem with repeatability or to perform improperly, check as described below.

Also, visit our website, <http://www.aadd.co.jp/>, for “Information Library” and “FAQ”.

If improper performance persists, contact the local A&D dealer for repair.

Checking that the balance performs properly

- Check the balance repeatability using the calibration weight. Be sure to place the weight in the center of the weighing pan. Pay attention to the airflow. Use the breeze break, or cover the balance if necessary.
- Check the balance repeatability, linearity and calibrated value using external weights with a known value.
- When the balance is built into a system, remove the balance from the system. Place it on a solid table and perform checking.

When the balance proper performance is confirmed, refer to page 13 to set up the installation site.

Checking that the operating environment or weighing method is proper

Operating environment

- Is the weighing table solid enough?
- Is the operating environment free from vibration and drafts? Has the breeze break been installed?
- Is there a strong electrical or magnetic noise source such as a motor near the balance?
- Is there a heat source near the balance?

Weighing method

- Does the weighing pan touch the breeze break or anything? Is the weighing pan installed correctly?
- Has the weight value been set to zero by using an RS-232C command (R command) before placing a sample on the weighing pan?
- Is the sample placed in the center of the weighing pan?
- Has the balance been warmed up for 30 minutes or more before weighing?
- Are the leveling feet of the weighing unit placed flat to the installation surface?

If not, the weight value will be unstable or the specified repeatability cannot be obtained.

Improve the installation condition, by securing the weighing unit or reducing the vibration that is conveyed to the weighing unit.

Sample and container

- Has the sample absorbed or lost moisture?
- Has the temperature of the sample, and the container if used, been allowed to equalize to the ambient temperature? Refer to “3.2. When Building into a System”.
- Is the sample charged with static electricity? Refer to “3.2. When Building into a System”.
- Is the sample of magnetic material such as iron? Use much care when weighing magnetic materials. Refer to “3.2. When Building into a System”.

8.2. Asking For Repair

If the balance needs service or repair, contact the local A&D dealer.

The balance is a precision instrument. Use much care when handling the balance and observe the following when transporting the balance.

- Use the original packing material.
- Remove the weighing pan from the weighing unit.

9. SPECIFICATIONS

		AD-4212C-300	AD-4212C-600		AD-4212C-301	
Weighing capacity		320 g	620 g		320 g / 51 g ^{*1}	
Maximum display		320.084 g	620.084 g		320.084 g / 51.0009 g	
Minimum weighing value (1 digit)		0.001 g	0.001 g		0.001 g / 0.0001 g	
Repeatability (Standard deviation)		0.001 g	0.001 g		0.001 g / 0.0002 g	
Linearity		±0.002 g		±0.005 g		±0.002 g
Stabilization time in seconds (typical at FAST under good environment)		0-30 g	0.5 s	0-30 g	0.5 s	When the minimum weighing value of 0.0001 g is selected
		30-320 g	1.0 s	30-620 g	1.0 s	When the minimum weighing value of 0.001 g is selected
Display refresh rate		Approx. 10 times/second* to 50 times/second				
I/O unit	RS-232C	Bi-directional, 2400 bps* to 19200 bps (WinCT-AD4212C communication software provided)				
Sensitivity drift		±2 ppm/°C (10°C to 30°C/50°F to 86°F)				
Operating environment		5°C to 40°C (41°F to 104°F), 85% RH or less (No condensation)				
Allowable eccentric load		0.1 Nm or less (With the center of the weighing pan as a reference)				
Calibration weight provided		200g (Conforming to OIML Class E2)				
Applicable weight values		50 g, 100 g, 200 g*, 300g	50 g, 100 g, 200 g*, 300g, 400 g, 500 g, 600 g	50 g, 100 g, 200 g*, 300g		
Weighing unit	Dimensions	59 (W) × 231 (D) × 91 (H) mm				
	Weighing pan	50 × 50 mm				
	Mass	Approx. 1.6 kg				
Connection cable		Approx. 10 m				
Unit display mode		g				
AC adapter		Output voltage 12 V (Confirm that the adapter type is correct for the local voltage and power receptacle type)				
Power consumption		Approx. 10 VA (supplied to the AC adapter)				

*1 Smart range (Refer to "5. SMART RANGE FUNCTION".)

*2 When the precision range is used

* Factory setting

		AD-4212C-3000	AD-4212C-6000		AD-4212C-3100	
Weighing capacity		3200 g	6200 g		3200 g / 510 g ^{*1}	
Maximum display		3200.84 g	6200.84 g		3200.84 g / 510.009 g	
Minimum weighing value (1 digit)		0.01 g	0.01 g		0.01 g / 0.001 g	
Repeatability (Standard deviation)		0.01 g	0.01 g		0.01 g / 0.002 g	
Linearity		±0.02 g	±0.04 g		±0.02 g	
Stabilization time in seconds (typical at FAST under good environment)		0-300 g	0.5 s	0-300 g	0.5 s	When the minimum weighing value of 0.001 g is selected
		300-3200 g	1.0 s	300-6200 g	1.0 s	When the minimum weighing value of 0.01 g is selected
Display refresh rate		Approx. 10 times/second* to 50 times/second				
I/O unit	RS-232C	Bi-directional, 2400 bps* to 19200 bps (WinCT-AD4212C communication software provided)				
Sensitivity drift		±2 ppm/°C (10°C to 30°C/50°F to 86°F)				
Operating environment		5°C to 40°C (41°F to 104°F), 85% RH or less (No condensation)				
Allowable eccentric load		0.3 Nm or less (With the center of the weighing pan as a reference)				
Calibration weight provided		200g (Conforming to OIML Class E2)				
Applicable weight values		50 g, 100 g, 200 g*, 300 g 500 g, 1000 g, 2000 g, 3000 g	200 g*, 500 g, 1000 g, 2000 g, 3000 g, 4000 g, 5000 g, 6000 g		50 g, 100 g, 200 g*, 300 g 500 g, 1000 g, 2000 g, 3000 g	
Weighing unit	Dimensions	59 (W) × 231 (D) × 91 (H) mm				
	Weighing pan	50 × 50 mm				
	Mass	Approx. 1.6 kg				
Connection cable		Approx. 10 m				
Unit display mode		g				
AC adapter		Output voltage 12 V (Confirm that the adapter type is correct for the local voltage and power receptacle type)				
Power consumption		Approx. 10 VA (supplied to the AC adapter)				

*1 Smart range (Refer to “5. SMART RANGE FUNCTION”.)

*2 When the precision range is used

* Factory setting

10. EXTERNAL DIMENSIONS

- AD-4212C-300 / 600 / 3000 / 6000 / 301 / 3100

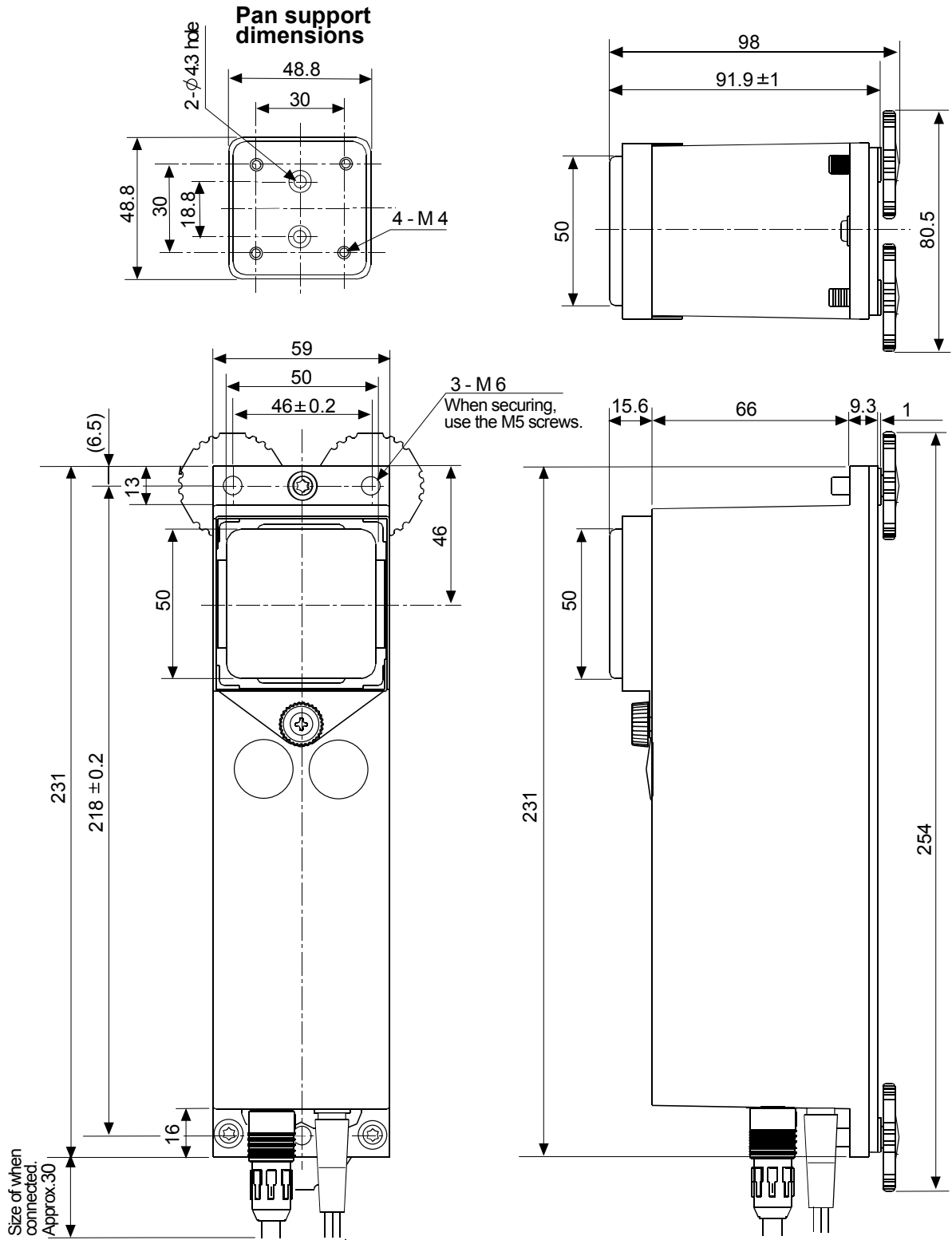

Unit: mm

11. OPTIONS

AX-KO3590-200 RS-232C cable 2 m

AX-KO3590-500 RS-232C cable 5 m

AX-KO3590-1000 RS-232C cable 10 m (provided with the balance as a standard accessory.)

AX-USB-9P: USB converter/Cable set

- USB converter (D-Sub 9 pin - USB)
 - RS-232C cable (D-Sub 9 pin - D-Sub 9-pin)
- * This RS-232C cable is not used with the AD-4212C series.

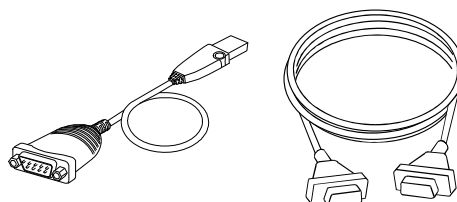

AD-8922A: Remote controller

- The AD-8922A can receive the weighing data, and performs re-zero and calibration manually.
- The AD-8922A can output the data using BCD (AD-8922A-01), comparator (AD-8922A-04), or analog out (AD-8922A-06), by selection of the option installed in the AD-8922A.

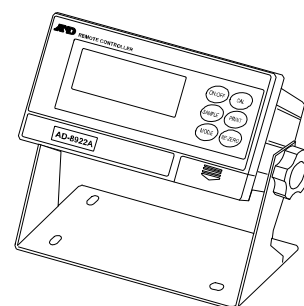

AD-8923-BCD/CC: Remote controller

- The AD-8923-BCD or AD-8923-CC can receive the weighing data, and performs re-zero and calibration manually.
- The AD-8923-BCD can output the data using BCD. The AD-8923-CC can output the data using CC-Link.

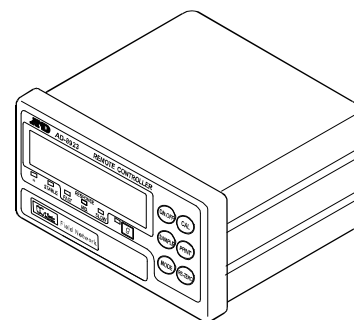

AD-8526: Ethernet converter

- The AD-8526 can convert the AD-4212C RS-232C data, for output to a local area network (LAN).

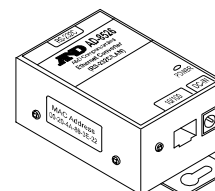

AD-1683: DC static eliminator

- A compact design with efficient static elimination
- No air blowing from a fan allows precision weighing

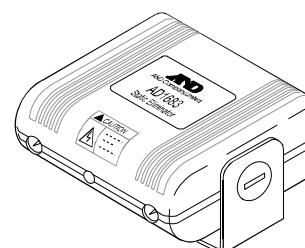

AD-1684A: Electrostatic field meter

- This option measures the amount of the static charge on the sample, tare or peripheral equipment and displays the result.
If those are found to be charged, discharge them using the AD-1683 DC static eliminator.

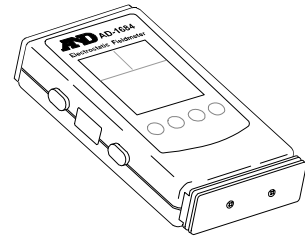

AD-8121B Printer

- Compact thermal dot-matrix printer
- Statistical function, clock and calendar function, interval print function, graphic print function, dump print mode
- 5 x 7 dots, 16 characters per line
- Print paper (AX-PP143, 45 (W) x 50 (L) mm , ø65 mm)
- AC adapter or alkaline battery

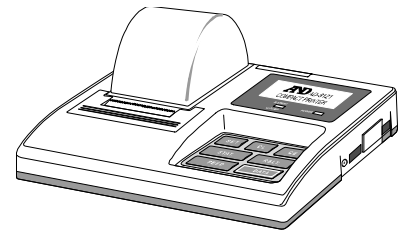





12. TERMS/INDEX

Terms

Stable value	The weight value when the stabilization indicator appears.
Environment	Ambient conditions such as vibration, drafts, temperature, static electricity or magnetic fields which affect the weighing operation.
Calibration	Adjustment of the balance using the calibration weight so that it can weigh accurately.
Output	To output the weighing data using the RS-232C interface.
Zero point	A weighing reference point or the zero display. Usually refers to the value displayed when nothing is on the weighing pan.
Digit	Unit of minimum display. Used for the balance, the minimum displayable weighing value.
Tare	To cancel the weight of a container which is not included in the weighing data.
Re-zero	To set the display to zero.
GLP	Good Laboratory Practice.
Repeatability	Variation in measured values obtained when the same weight is placed and removed repetitively. Usually expressed as a standard deviation. e.g. Standard deviation=1 digit: This means that the measured values fall within ± 1 digit at a probability of about 68%.
Stabilization time	Time required after a sample being placed, until the stabilization indicator illuminates and the weighing data is displayed.
Sensitivity drift	An affect that a change in temperature causes to the weighing data. Expressed as temperature coefficient. e.g. Temperature coefficient = 2 ppm/ $^{\circ}$ C : If a load is 100 g and the temperature changes by 10 $^{\circ}$ C, the value displayed changes by the following value. $0.0002\%/^{\circ}$ C x 10 $^{\circ}$ C x 100 g = 2 mg

Index

Symbols

C_R Carriage return	22, 23, 24, 25, 26, 27	AD-1684A.....	37
L_F Line feed.....	22, 23, 24, 25, 26, 27	AD-8121B.....	37
□ space mark.....	25, 26, 27	AD-8526	4, 5, 36
 Processing indicator	17	AD-8922A.....	3, 4, 5, 36
 Stabilization indicator.....	17	AD-8923-BCD	3, 36
 Standby indicator	17	AD-8923-CC.....	36
 Weighing speed indicators.....	17	Allowable eccentric load	13, 33, 34
A		Ambient humidity	14
AC adapter	8, 10, 12, 16	Anti-static agent	14
AD-1683.....	14, 36	Anti-static wrist strap.....	14
		AX- KO3590-200.....	5, 36

AX- KO3590-500 5, 36
 AX- KO3590-1000 5, 36
 AX-USB-9P 4, 36

B

BCD 3, 5, 36
 Breeze break 8, 14, 31

C

C command 24
 Cable set 36
CAL button 17, 19
 CAL command 24
 Calibration 16, 18, 19, 38
 Calibration weight 10, 18, 19, 31, 33, 34
 CC-Link 3, 5, 36
 Charged material 14
 Conductive acrylic fiber 14
 Connect 4, 5
 CR 22, 23, 24

D

DC static eliminator 14, 36
 Digit 38
 Discharge 14
 Display refresh rate 33, 34

E

Earth ground 14
 Electrostatic field meter 37
 Ethernet converter 3, 36

F

FAST 3, 18, 33, 34

G

Grounding terminal 8

I

I/O unit 33, 34
 Insulators 14

L

LAN 5
 Leveling foot 8, 9
 LF 22, 23, 24
 Linearity 33, 34

M

Maximum display 33, 34
MID. 18
 Minimum weighing value 3, 33, 34
MODE button 17

O

OFF command 24
ON/OFF button 17
 ON command 24
 Operating environment 33, 34

P

P command 24
 Pan support 8
 Pan support boss 8
 Personal computer 4
 Plastic 14
 PLC 5
 Powdery samples 14
 Precision range 21, 33, 34
PRINT button 17, 19
 Printer 37
 PRT command 24

Q

Q command 24

R

R command 21, 24, 25

Remote controller	36
Repeatability	31, 33, 34, 38
RE-ZERO button	17
RS-232C	4, 5, 22
RS-232C cable	8, 10, 36

S

S command	24
SAMPLE button	17
Sensitivity drift	33, 34, 38
SIR command	24
SLOW	18
Smart range function	21, 33, 34
SMP command	21, 24
Stabilization time	3, 33, 34, 38
Stable value	18, 38
Standard range	21
Standby indicator	17
Static charge	15
Static electricity	11, 13, 32, 38

U

U command	24
Unit	17
USB	4
USB converter	4, 36

V

Vibration	13
-----------------	----

W

Warm up	10, 12, 16
Weighing capacity	3, 16, 33, 34
Weighing pan	8
Weighing speed	10, 17, 18
WinCT-AD4212C	3, 8, 17

Z

Zero point	19, 38
------------------	--------



A&D Company, Limited

3-23-14 Higashi-Ikebukuro, Toshima-ku, Tokyo 170-0013, JAPAN
Telephone: [81] (3) 5391-6132 Fax: [81] (3) 5391-6148

A&D ENGINEERING, INC.

1756 Automation Parkway, San Jose, California 95131, U.S.A.
Telephone: [1] (408) 263-5333 Fax: [1] (408)263-0119

A&D INSTRUMENTS LIMITED

Unit 24/26 Blacklands Way, Abingdon Business Park, Abingdon, Oxfordshire OX14 1DY United Kingdom
Telephone: [44] (1235) 550420 Fax: [44] (1235) 550485

A&D AUSTRALASIA PTY LTD

32 Dew Street, Thebarton, South Australia 5031, AUSTRALIA
Telephone: [61] (8) 8301-8100 Fax: [61] (8) 8352-7409

A&D KOREA Limited

한국에이.엔.디(주)
서울특별시 영등포구 국제금융로6길33 (여의도동) 맨하탄빌딩 817 우편 번호 150-749
(817, Manhattan Bldg., 33. Gukjegeumyung-ro 6-gil, Yeongdeungpo-gu, Seoul, 150-749 Korea)
전화: [82] (2) 780-4101 팩스: [82] (2) 782-4280

ООО A&D RUS

ООО "ЭЙ энд ДИ РУС"
121357, Российская Федерация, г.Москва, ул. Вереysкая, дом 17
(Business-Center "Vereyskaya Plaza-2" 121357, Russian Federation, Moscow, Vereyskaya Street 17)
тел.: [7] (495) 937-33-44 факс: [7] (495) 937-55-66

A&D INSTRUMENTS INDIA PRIVATE LIMITED

ऐ&डी इन्स्ट्रुमेन्ट्स इण्डिया प्रा० लिमिटेड
509, उद्योग विहार , फेस -5, गुडगांव - 122016, हरियाणा , भारत
(509, Udyog Vihar, Phase-V, Gurgaon - 122 016, Haryana, India)
फोन : 91-124-4715555 फैक्स : 91-124-4715599