



A TEREX BRAND

Operator's Manual

Serial number range

GTH-5519 (*Perkins Tier III*) From serial n.: 19388
To serial n.: 24471

GTH-5519 (*Deutz Tier III*) From serial n.: 19006
To serial n.: 25040

With Maintenance
Information

First Edition
Eleventh Printing
Part No. 57.0009.0412

Important

Read, understand and obey these safety rules and operating instructions before operating the machine. Only trained and qualified personnel shall be authorized to operate the machine. This manual shall be kept with the machine at all times.

For any further information, please call Terexlift.

Contact us:

ZONA INDUSTRIALE I-06019 UMBERTIDE
(PG) - ITALY
Telephone +39 075 941811
Telefax +39 075 9415382

Technical Assistance Service

Telephone: +39 075 9418129
+39 075 9418175

e-mail: UMB.Service@terex.com

Contents

Introduction.....	Page 3
Machine Identification.....	Page 5
Symbols Used On The Machine.....	Page 7
Labels And Plates Applied On The Machine	Page 9
Safety Precautions	Page 17
Description Of The Main Components...	Page 25
Controls And Instruments.....	Page 27
Inspections	Page 41
Operating Instructions	Page 45
Transporting The Machine.....	Page 57
Maintenance.....	Page 61
Faults And Troubleshooting.....	Page 85
Optional Attachments	Page 89
Specifications	Page 95
Load Charts.....	Page 99
Diagrams And Schemes.....	Page 107

Original Instructions

First Edition: Tenth Printing, October 2011

For the electronic version of this manual visit
www.genielift.com/operator_manuals.asp

© Copyright 2006 **TEREXLIFT srl** - All rights reserved

Produced by:

TEREXLIFT Technical Literature Dept.

Umbertide (PG) Italy

Introduction

■ Symbols



Safety alert symbol: used to alert you to potential personal injury hazards. Obey all safety messages that follow this symbol to avoid possible injury or death



DANGER *Red: indicates a hazardous situation which, if not avoided, will result in death or serious injury.*



WARNING *Orange: indicates a hazardous situation which, if not avoided, could result in death or serious injury.*



CAUTION *Yellow: indicates a hazardous situation which, if not avoided, could result in minor or moderate injury.*



NOTICE *Blue: indicates a hazardous situation which, if not avoided, could result in property damage.*



PROTECT THE ENVIRONMENT *Green: used to draw the attention to important information on environment protection.*



Intentionally blank page

Machine Identification

Check that the operator handbook refers to the delivered machine.

■ MODEL AND TYPE

Handler with telescopic boom:

models: **GTH-5519**

■ MANUFACTURER

TEREXLIFT srl

Zona Industriale - I-06019 UMBERTIDE (PG) - ITALY

Enrolled in the register of companies at the Court of Perugia under no. 4823

C.C.I.A.A. 102886

Fiscal Code/V.A.T. no. 00249210543

■ APPLICABLE STANDARDS

For the operator's safety, the following standards were obeyed during the risk assessment of the handler fitted with telescopic boom norme:

<i>Directive</i>	<i>Title</i>
ANSI/ITSDF B56.6-2002 part III	where applicable.
CSA B335-04	where applicable.

■ MACHINE IDENTIFICATION PLATES

The following data plates are applied on the machine:

Machine data plate

The identification plate contains the main identification data of the machine like model, serial number and year of manufacture.

The data plate is applied on the front right side of the chassis.

ROPS-FOPS cab type-approval plate

The ROPS - FOPS type-approval plate is located inside the driving cab above the rear glass.

Fork data plate

Placed on the left side of the fork frame.

This plate shows the identification data of fork such as model, serial number, year of manufacture, weight, nominal payload, centre of the load and model of the machine on which the forks are installed.

Machine Identification

■ CHASSIS SERIAL NUMBER







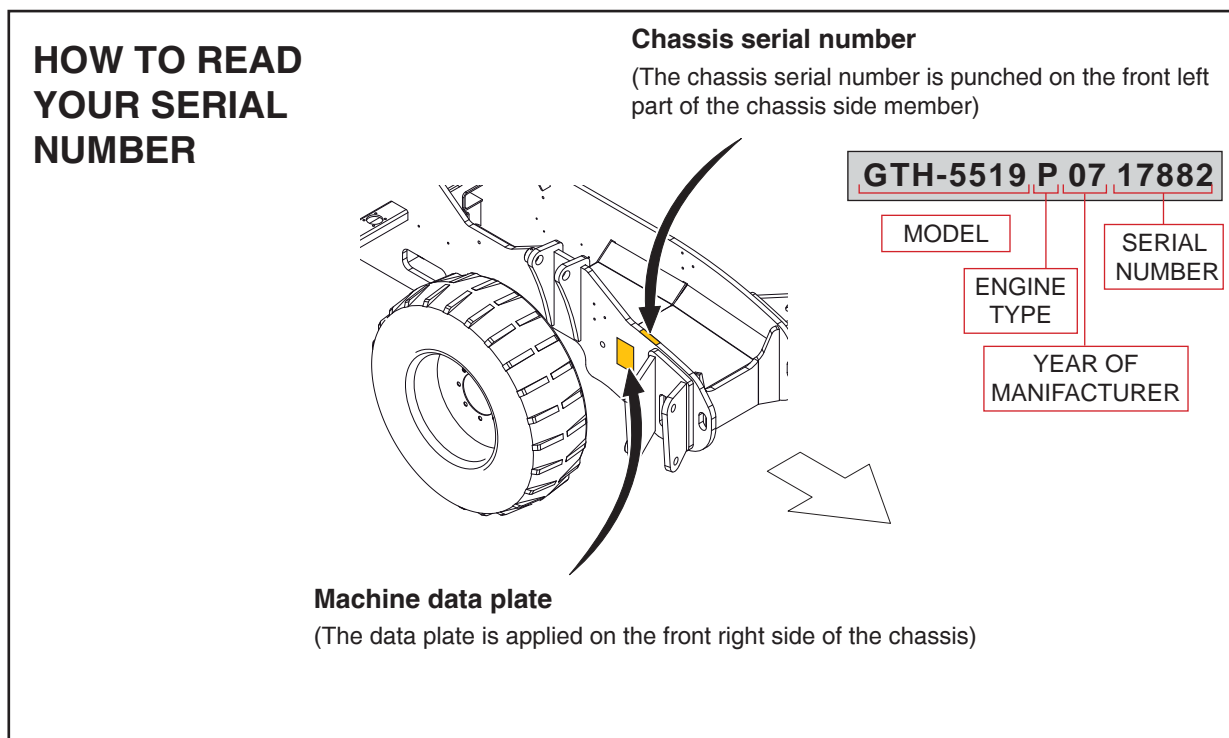



























The chassis serial number is punched on the front left part of the chassis side member.

■ IDENTIFICATION PLATES OF THE MAIN PARTS

The plates of the main components, not directly manufactured by **TEREXLIFT srl** (for instance, engines, pumps, etc.), are located where originally applied by the manufacturers.



Symbols Used On The Machine

 Fuel level	 General alarm	 Low engine oil pressure	 Parking brake	 Battery charge
 Hydraulic oil filter clogged	 Hydraulic oil filter	 Low Hydraulic Oil Level	 Turn signals	 High beam
 Not active	 Not active	 Glow Plugs Preheating	 High Coolant Temperature	 Low beam
 Rear Wheel Aligned	 Air Filter Restricted	 Hour-meter	 Hydraulic Oil Temperature Indicator	 Position lights
 Windscreen washer	 Cab ventilation fan	 Position lights	 Fog lamp	 Hazard warning lights
 Continuous Oil Flow	 Steering mode	 Anchorage points	 Fuel cap	 Hydraulic oil
 Engine oil level	 Moving gears	 Risk of crushing injury to the hands	 Hot surfaces. Risk of burns	

Symbols Used On The Machine

HAZARD PICTORIAL DESCRIPTIONS

 <p>Electrocution Hazard</p>	 <p>Maintain required clearance.</p>	 <p>Falling Object Hazard</p>	 <p>No people under load.</p>	 <p>Fall Hazard</p>
 <p>No riders.</p>	 <p>Overturning Hazard</p>	 <p>Keep load low.</p>	 <p>Bodily Injury Hazard</p>	 <p>Always wear seat belt.</p>
 <p>Injection Hazard</p>	 <p>Use cardboard to search for leaks.</p>	 <p>Overturning Hazard</p>	 <p>Read the operator's manual.</p>	 <p>Crush Hazard</p>
 <p>Keep away from moving parts.</p>	 <p>Operate from operator's station.</p>	 <p>Bodily injury hazard.</p>	 <p>Crush Hazard</p>	 <p>Lower forks. Set parking brake.</p>
 <p>Burn Hazard</p>	 <p>Allow system to cool.</p>	 <p>Overturning Hazard</p>	 <p>Keep away from belts and fans.</p>	 <p>Explosion/Burn Hazard</p>
 <p>No smoking. No open flame.</p>	 <p>Burn Hazard</p>	 <p>Allow surfaces to cool.</p>	 <p>Crush Hazard</p>	 <p>Support boom when performing maintenance.</p>





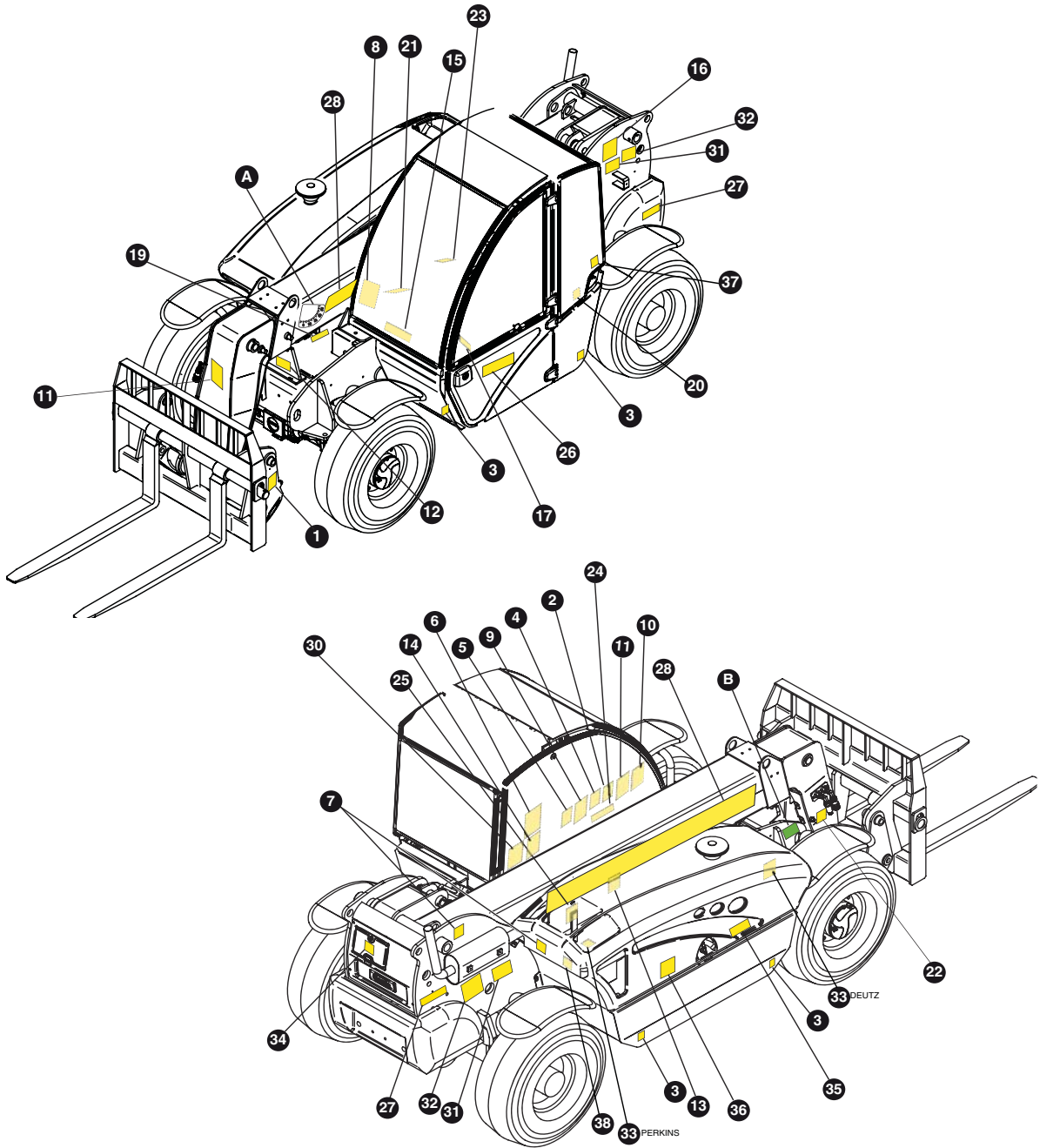

Labels And Plates Applied On The Machine

 Shading indicates decal is hidden from view, i.e. under covers.

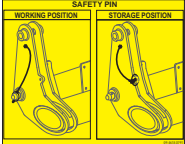



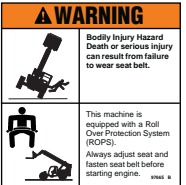
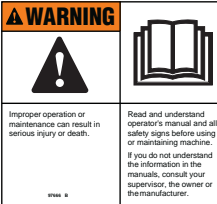

Labels And Plates Applied On The Machine

Use the pictures on these pages to verify that all decals are legible and in place. The following chart shows quantities and description too.

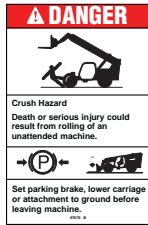
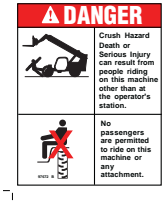
Ref.	Decal	Code	Description	Qt.
1		09.4618.0791	Safety pin operation	1
2		97669C	Warning - Falling Object Hazard	1
3		09.4618.0061	Tyre inflation sticker P= 4.5 bar / 65 psi	4
4		114352B	Overturning Hazard for Cab	1
5		97665B	Warning - Bodly Injury Hazard	1
6		97666B	Warning - Improper Operation	1
7		97667B	Warning - Burn Hazard	2







Labels And Plates Applied On The Machine

Ref.	Decal	Code	Description	Qt.
8		97670B	Warning - Crush Hazard, Parking Brake	1
9		97672B	Danger - Crush Hazard, No Riders	1
10		114356A	Oveturing hazard_use load chars	1
11		97673B	Danger - Fall Hazard, No Riders	2
12		97674B	Warning - Crush Hazard, Overhead Parts	1
13		97675B	Warning - Burn Hazard, Hot Component	1



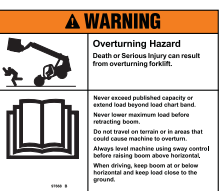

Labels And Plates Applied On The Machine

Ref.	Decal	Code	Description	Qt.
14		97676B	Danger - Electrocutation Hazard	1
15		97688	Emergency Exit Handle	1
16		82558B	Warning - Injection Hazard	1
17		09.4618.0928	Label - Hydraulic Oil	1
19		09.4618.0786	Label - Testing ports	1
20		09.4618.0776	Label - Upper Door Internal Unlock System	1
21		09.4618.0781	Label - Flow Reversal Button	1
22		09.4618.0782	Caution - Connect./disconnect. Quick Coupling <i>OPTIONAL</i>	1
23		09.4618.0780	Label - Continuous Flow Knob (up to s/n: 24128)	1

Labels And Plates Applied On The Machine

Ref.	Decal	Code	Description	Qt.
23		09.4618.1634	Label - Continuous Flow Knob <i>(from s/n: 24129)</i>	1
24		09.4618.0819	Label - Lever Controls	1
25		09.4618.0792	Label - Engine Cover Closing	1
26		114470	Cosmetic - GENIE Logo	1
27	<i>GTH-5519</i>	09.4618.0644	Cosmetic - GTH-5519	2
28		09.4618.0643	Cosmetic - Genie GTH-5519	2
29		09.4618.0109	Sticker With Various Warnings	1
30		97668B	Warning - Overturning Hazard	1

Labels And Plates Applied On The Machine

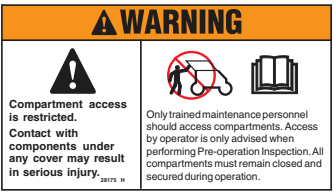
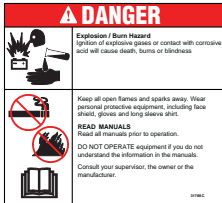
Ref.	Decal	Code	Description	Qt.
31	 <p>WARNING</p> <p>Crush Hazard Machine movement can cause serious injury or death.</p> <p>Stay away from machine.</p> <p>114365 A</p>	114365A	Crush Hazard	2
32	 <p>WARNING</p> <p>Falling Object Hazard Death or Serious Injury can result from falling objects.</p> <p>Do not enter the area under or around the boom when the forks are off the ground or the engine is running.</p> <p>114367 B</p>	114367B	Falling Objects	2
33	 <p>WARNING</p> <p>Bodily injury hazard. Contact with moving parts may cause serious injury.</p> <p>Stay clear of belts and fan when engine is running.</p> <p>28162 C</p>	28162C	Fan Belt	1
34	 <p>28159 024C</p>	28159C	Diesel	1
35	 <p>WARNING</p> <p>Compartment access is restricted. Contact with components under any cover may result in serious injury.</p> <p>Only trained maintenance personnel should access compartments. Access by operator is only advised when performing Pre-operation Inspection. All compartments must remain closed and secured during operation.</p> <p>28175 H</p>	28175H	Warning for Engine Cover	1
36	 <p>DANGER</p> <p>Explosion / Burn Hazard Ignition of explosive gases or contact with corrosive acid will cause death, burns or blindness.</p> <p>Keep all open flames and sparks away. Wear personal protective equipment, including face shields, gloves and long sleeve shirt.</p> <p>READ MANUALS Read all manuals prior to operation. DO NOT OPERATE equipment if you do not understand the information in the manuals. Consult your supervisor, the dealer or the manufacturer.</p> <p>31788 C</p>	31788C	Warning - Burn Hazard, Hot Component	1

Labels And Plates Applied On The Machine

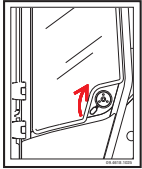
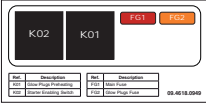
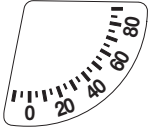
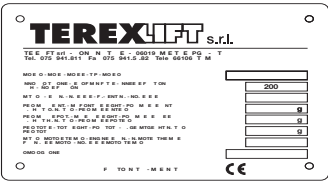
Ref.	Decal	Code	Description	Qt.
37		09.4618.1025	Label - Upper Door External Unlock System	1
38		09.4618.0949	Label - Fuses and Relays Engine Board	1
A		09.4618.0205	Boom tilting degree	1
B		09.4616.0101	Machine data plate. The identification plate contains the main identification data of the machine.	1

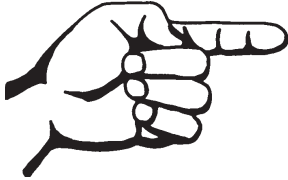

Intentionally blank page

Safety Precautions

■ DAMAGED MACHINE HAZARDS

- Do not use a damaged or defective machine.
- Do a thorough pre-operation inspection of the machine and test all functions before each work shift. Tag and remove from service a damaged or defective machine.
- Make sure that all maintenance jobs have been carried out as specified in this manual and the appropriate service manual.
- Make sure that all decals are in place and legible.
- Make sure that the operator's manual is legible and placed in the special container located in the machine.

■ PERSONAL INJURY HAZARDS

- Do not operate the machine in case of hydraulic oil or air leak. Air or hydraulic oil leaks can penetrate or burn the skin.
- Always operate the machine in a well ventilated area to avoid carbon monoxide poisoning.
- Do not lower the boom if the area underneath is not clear of personnel or obstructions.

■ SAFETY DEVICES



Several safety devices have been fitted to the machine. They must never be tampered with or removed.

Regularly check the efficiency of such devices. In case of faults, stop working immediately and proceed in replacing the defective device. For the checking procedures, read chap. "Maintenance"

Safety Precautions



Not observing the instructions and safety rules in this manual may result in death or serious injury.

Do not operate the machine unless:

- You learn and practice the principles of safe machine operation contained in this operator's manual.
 - 1. Avoid hazardous situations.** Read and understand the safety instructions before going on to the next chapter.
 - 2. Always perform a pre-operation inspection.**
 - 3. Always test the machine functions prior to use.**
 - 4. Inspect the work place.**
 - 5. Only use the machine for the intended application.**
- Read, understand and obey the manufacturer's instructions and the safety rules, the safety and operator's manuals, and the decals applied on the machine.
- Read, understand and obey the employer's safety rules and worksite regulations.
- Read, understand and obey the applicable national regulations.
- Only trained personnel informed on the safety rules can operate the machine.

■ GENERAL REMARKS

Most accidents occurring while working, repairing or maintaining machines, are caused by not complying with the basic safety precautions.

Therefore, it is necessary to pay steady attention to the potential hazards and the effects that may come of operations carried out on the machine.

NOTICE

If you recognise hazardous situations, you can prevent accidents!



The instructions given in this handbook are the ones established by TEREXLIFT. They do not exclude other safe and most convenient ways for the machine installation, operation and maintenance that take into account the available spaces and means.

If you decide to follow instructions other than those given in this manual, you shall absolutely:

- be sure that the operations you are going to carry out are not explicitly forbidden;
- be sure that the methods are safe, say, in compliance with the rules and provisions given in this section;
- be sure that the methods cannot damage the machine directly or indirectly or make it unsafe;
- contact TEREXLIFT Assistance Service for any suggestion and the necessary written permission.

Safety Precautions

■ REQUISITES OF THE PERSONNEL IN CHARGE

■ Requisites of the MACHINE OPERATORS

The operators who use the machine regularly or occasionally (i.e. for transport reasons) shall have the following prerequisites:

health:

before and during any operation, operators shall never take alcoholic beverages, medicines or other substances that may alter their psycho-physical conditions and, consequently, their working abilities.

physical:

good eyesight, acute hearing, good co-ordination and ability to carry out all required operations in a safe way, according to the instructions of this manual.

mental:

ability to understand and apply the enforced rules, regulations and safety precautions. They shall be careful and sensible for their own as well as for the others' safety and shall desire to carry out the work correctly and in a responsible way.

emotional:

they shall keep calm and always be able to evaluate their own physical and mental conditions.

training:

they shall read and be familiar with this handbook, its enclosed graphs and diagrams, the identification and hazard warning plates. They shall be skilled and trained about the machine use.

NOTICE

The operator shall have a licence (or a driving licence) when provided for by the laws enforced in the country where the machine works. Please, ask the competent bodies. In Italy the operator must be at least 18 year old.

■ Requisites of the SERVICEMEN

The personnel charged with the machine maintenance shall be qualified, specialised in the maintenance of telehandlers, and shall have the following prerequisites:

physical:

good eyesight, acute hearing, good co-ordination and ability to carry out all required maintenance operations in a safe way, according to this manual.

mental:

ability to understand and apply the enforced rules, regulations and safety precautions. They shall be careful and sensible for their own as well as for the others' safety and shall desire to carry out the work correctly and in a responsible way.

training:

they shall read and be familiar with this handbook, its enclosed graphs and diagrams, the identification and warning plates. They shall be skilled and trained about the machine functioning.

NOTICE

From a technical point of view, the ordinary maintenance of the machine is not a complex intervention and can be carried out by the machine operator, too, provided he has a basic knowledge of mechanics.

Safety Precautions

WORKING CLOTHES

During work, but especially when maintaining or repairing the machine, operators must wear suitable protective clothing:

- Overalls or any other comfortable garments. Operators should not wear clothes with large sleeves or objects that can get stuck in moving parts of the machine.
- Protective helmet.
- Protective gloves.
- Working shoes.



Use only type-approved working clothing in good condition.

Personal PROTECTIVE EQUIPMENT

Under special working conditions, the following personal protective equipment should be used:

- Breathing set (or dust mask).
- Ear-protectors or equivalent equipment.
- Goggles or facial masks.

OTHER DANGERS

Hazards on the JOBSITE

Always take into account the features of the job site where you are going to work:

- Always examine the working area and compare it with the machine dimensions in the different configurations.



The machine is not electrically insulated and does not provide protection from contact with or proximity to electrical power lines. Always keep at a minimum safe distance from the telescopic boom and the lifted load. Electrical hazards!

DEATH OR INJURY CAN RESULT FROM CONTACTING ELECTRIC POWER LINES.

ALWAYS CONTACT THE ELECTRIC POWER LINES OWNER. THE ELECTRIC POWER SHALL BE DISCONNECTED OR THE POWER LINES MOVED OR INSULATED BEFORE MACHINE OPERATIONS BEGIN

POWER LINE VOLTAGE	REQUIRED CLEARANCE
0 to 50 kV	10 ft 3.00 m
50 to 200 kV	15 ft 4.60 m
200 to 350 kV	20 ft 6.10 m
350 to 500 kV	25 ft 7.62 m
500 to 750 kV	35 ft 10.67 m
750 to 1000 kV	45 ft 13.72 m

- Keep away from the machine in case of contact with energized power lines. Personnel on the ground must never touch or operate the machine until energized power lines are shut off.



Do not at any time use the machine during a storm.

Safety Precautions

■ OPERATION or MAINTENANCE hazards

Before any operation, following precautions should be taken:

- First of all, make sure that the maintenance interventions have been carried out with care according to the established schedule.



Set the machine to working configuration and sway it. Use the special inclinometer to the right of the driving place to check that the machine is level before operating it.

- Ensure you have enough fuel to avoid a sudden stop of the engine, especially during a crucial manoeuvre.
- Clean instruments, data plates, lights and the cab windscreen thoroughly.
- Check the correct functioning of all the safety devices installed on the machine and in the job site.
- In case of troubles or difficulties, inform the foreman at once. Never start working under unsafe conditions.
- Do not carry out any repair work in a makeshift way to start working!

During work, and especially maintenance, always pay the greatest attention:

- Do not walk or stop under raised loads or machine parts supported by hydraulic cylinders or ropes only.
- Keep the machine handholds and access steps always clean from oil, grease or dirt to prevent falls or slips.



- When entering/leaving the cab or other raised parts, always face the machine; never turn the back.

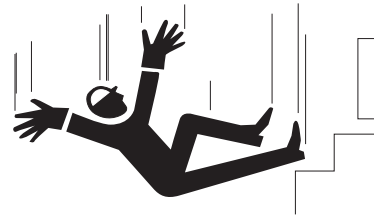

- When carrying out operations at hazardous heights (over 1.5 meters from the ground), always use approved fall restraint or fall arrest devices.
- Do not enter/leave the machine while it is running.
- Do not leave the driving place when the machine is running.
- Neither stop nor carry out interventions under or between the machine wheels when engine is running. When maintenance in this area is required, stop the engine.
- Do not carry out maintenance or repair works without a sufficient lighting.
- When using the machine lights, the beam should be oriented in order not to blind the personnel at work.
- Before applying voltage to electric cables or components, check their connection and proper functioning.
- Do not carry out interventions on electric components with voltage over **48V**.
- Do not connect wet plugs or sockets.
- Plates and hazard warning stickers shall never be removed, hidden or become unreadable.
- Except for maintenance purposes, do not remove safety devices, shields, protection cases, etc. Should their removal be necessary, stop the engine, remove them with the greatest care and always remember to refit them before starting the engine and using the machine again.
- Before any maintenance or repair work, stop the engine and disconnect the batteries.

Safety Precautions

- Do not lubricate, clean or adjust moving parts.
- Do not carry out operations manually when specific tools are provided for this purpose.
- Avoid the use of tools in bad condition or use in an improper way i.e. pliers instead of adjustable wrenches, etc.
- Applying loads in different points of the attachment holding plate is forbidden.
- When working, do not give instructions or signs to several people at the same time. Instructions and signs must be given by one person only.
- Always pay due attention to the instructions given by the foreman.
- Never distract the operator during working phases or crucial manoeuvres.
- Do not call an operator suddenly, if unnecessary.
- Do not frighten an operator or throw objects by any means.
- After work, never leave the machine under potentially dangerous conditions.



Any intervention on the hydraulic circuit must be carried out by authorised personnel.

The hydraulic circuit of this machine is fitted with pressure accumulators. You and others could be seriously injured if accumulators are not completely depressurised.

For this purpose, shut the engine down and step on the brake pedal 8/10 times.



- Before carrying out operations on hydraulic lines under pressure or disconnecting hydraulic components, ensure the relevant line has been previously depressurised and does not contain any hot fluid.
- Do not empty catalytic mufflers or other vessels containing burning materials without taking the necessary precautions.
- After any maintenance or repair work, make sure that no tool, cloth or other object has been left within machine compartments, fitted with moving parts, or where suction and cooling air circulates.
- **■ MACHINE OPERATION hazards**
Absolutely avoid the following work situations:
 - Do not handle loads beyond the maximum capacity of the machine.
 - Do not raise or extend the boom if the machine is not on a firm, level surface.
 - Do not operate the machine in strong wind. Do not increase the surface area of the machine or forked load exposed to the wind. Increasing the area exposed to the wind will decrease machine stability.
 - Use extreme caution and slow speeds when the machine is driven across uneven or unstable grounds, slippery surfaces or near trenches or drop-offs.
 - Limit travel speed according to ground conditions, slopes, presence of personnel or other factors which may cause collision.
 - Do not place or attach overhanging loads to any part of the machine.

Safety Precautions

■ EXPLOSION OR FIRE hazards

- Do not start the engine if you smell or detect LPG, gasoline, diesel fuel or other explosive substances.
- Do not refuel the machine with the engine running.
- Refuel the machine and charge the battery only in a well ventilated area away from sparks, naked flames and lighted cigarettes.
- Do not operate the machine in dangerous environments or in places with flammable or explosive gases or materials.
- Do not inject ether in engines equipped with glow plugs.
- Do not leave fuel cans or bottles in unsuitable places.
- Neither smoke nor use open flames in areas subject to fire dangers and in presence of fuel, oil or batteries.
- Carefully handle all flammable or dangerous substances.
- Do not tamper with fire-extinguishers or pressure accumulators.

■ DAMAGED COMPONENT hazards

- Do not use battery chargers or batteries with a voltage above 12V to start the engine.
- Do not use the machine as a ground for welding.

■ PERSONAL INJURY hazards

- Do not operate the machine in case of hydraulic oil or air leak. Air or hydraulic oil leaks can penetrate or burn the skin.
- Always operate the machine in a well ventilated area to avoid carbon monoxide poisoning.
- Do not lower the boom if the area underneath is not clear of personnel or obstructions.



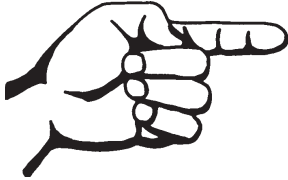

Intentionally blank page

Description Of The Main Components

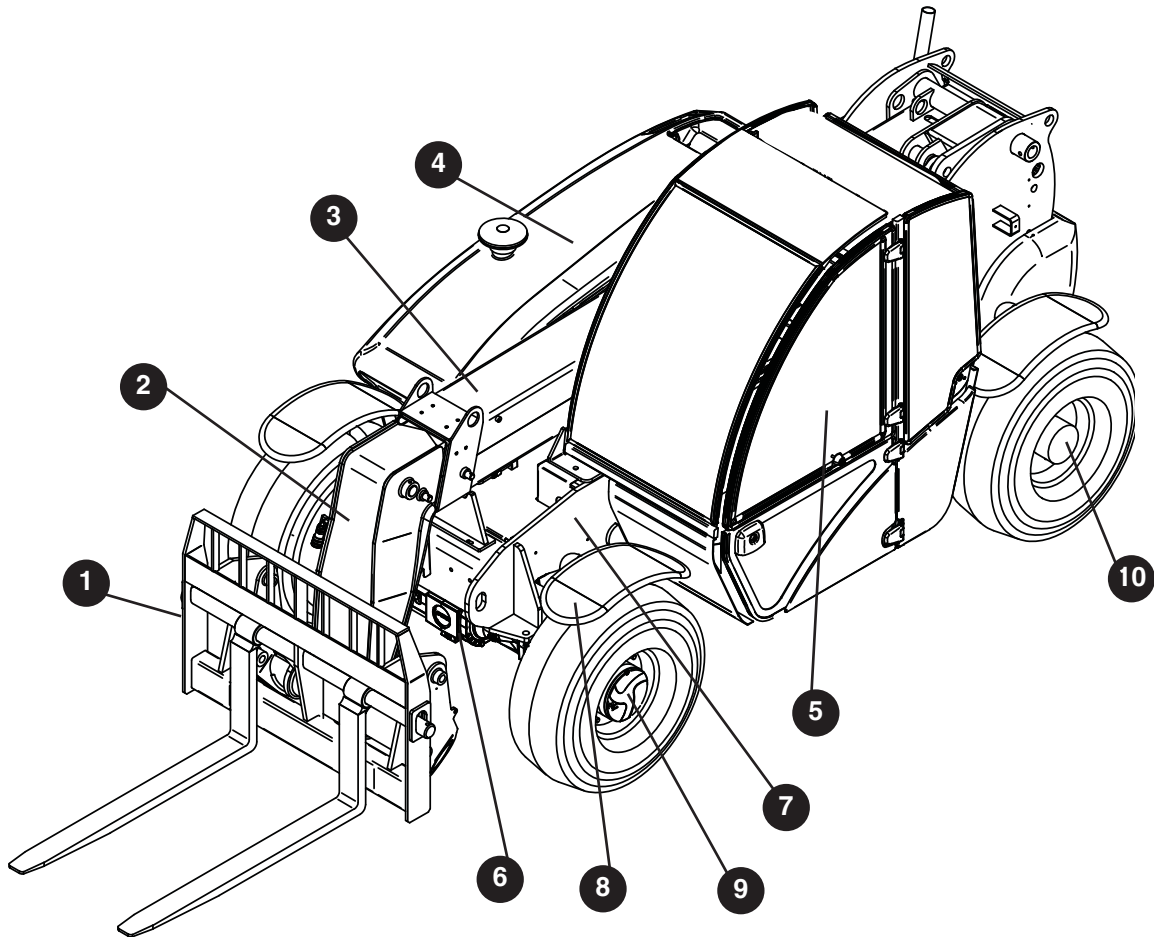

1. Forks
2. 2nd boom section
3. 1st boom section
4. Engine hood
5. Driving cab
6. Front axle
7. Chassis
8. Left front wheel mud-guard
9. Left front wheel reduction gear
10. Left rear wheel reduction gear

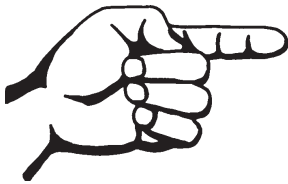

Intentionally blank page

Controls And Instruments

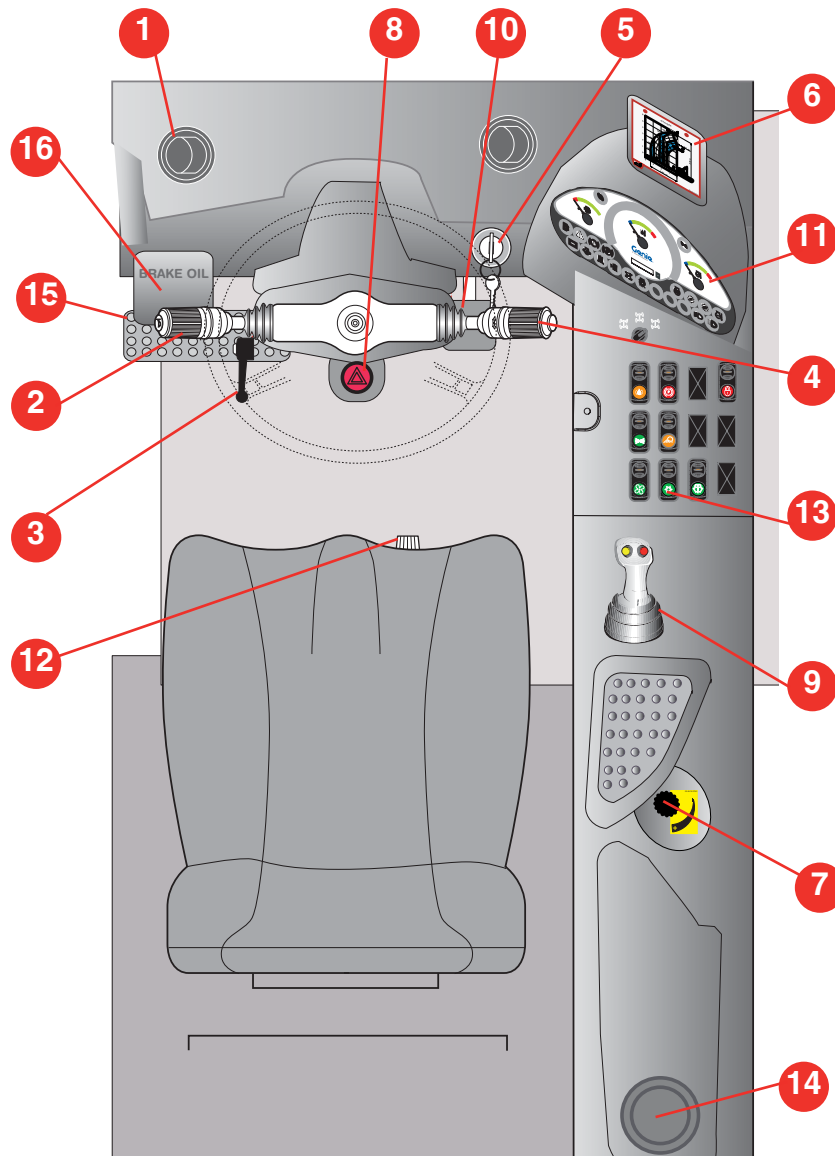

- | | |
|--|--------------------------------|
| 1. Fresh Air Flap | 9. Multipurpose Control Lever |
| 2. Forward/reverse Gear Selector Lever | 10. Gas Pedal |
| 3. Steering Column Angle Adjustment | 11. Instruments Dashboard |
| 4. Turn Signals - Windscreen Washer - Horn | 12. Cab Heater Control Knob |
| 5. Ignition Switch | 13. Fuses And Relays Board |
| 6. Load Charts Holder | 14. Windscreen water reservoir |
| 7. Continuous Oil Flow Potentiometer | 15. Service Brake Pedal |
| 8. Hazard Warning Lights Switch | 16. Service Brake Oil Tank |

Controls And Instruments

■ Ignition switch

Three-position switch:

- 0** No circuit under voltage, key can be removed and engine is stopped
- 1** Circuits under voltage, presetting for the engine starting. Board controls and instruments are on.
- 2** Engine starting; when released, key springs back to pos.1 automatically.

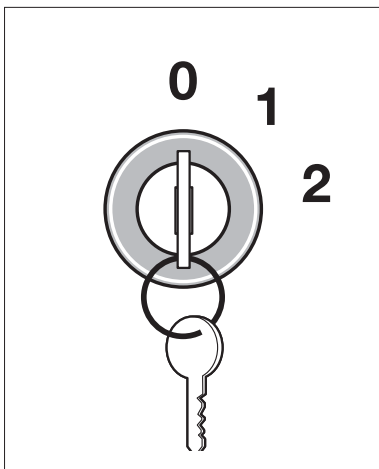

■ Forward/reverse gear selector switch

Three-position switch with lock in neutral position:

- 0** Neutral position; no gear engaged
- 1** Shift lever to pos. 1 to select the forward gear
- 2** Shift lever to pos. 2 to select the reverse gear

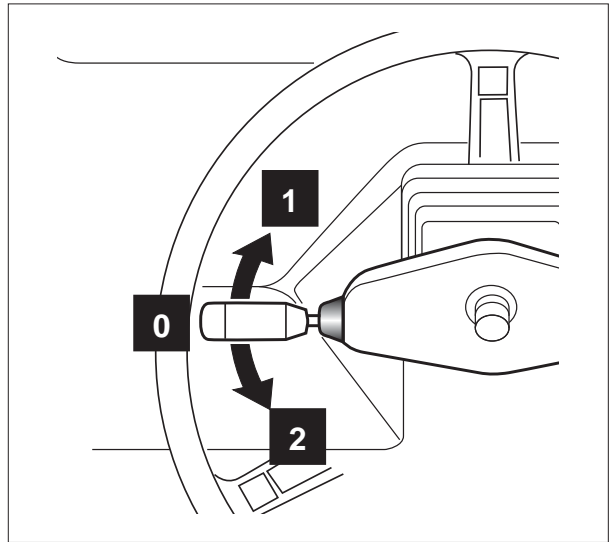

■ Horn function:

When sliding the lever along its axis, horn switches on, independently from other pre-set functions.

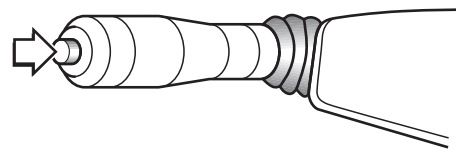

Controls And Instruments

■ Turn signals - Lights (OPTIONAL) (only with closed cabin)

■ Turn signals function:

Set lever to pos. 1 to indicate a turn leftwards or to pos. 2 to indicate a turn rightwards.

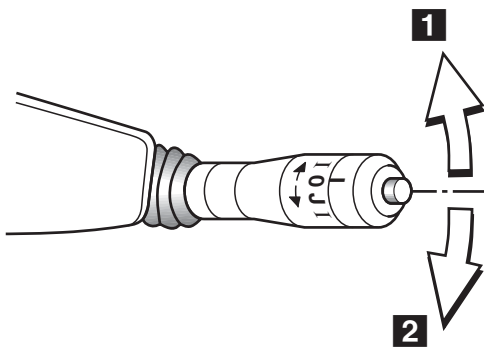

■ Lights function:

To switch the handler lights, lever can be set to three different positions along its horizontal axis:

- 0 low beam ON, stable condition
- 1 high beam ON, stable condition
- 2 high beam used for intermittent signalling; when released, the lever springs back to position 0.

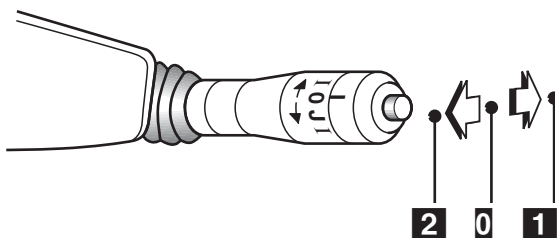

*When starting the engine the lights of all the pushbuttons turn automatically on!
Only the switching-on of the orange warning light sets on the top of the pushbutton will indicate the activation of the function.*

17 Road lights switch (OPTIONAL)

Three-position switch placed on the right side of the dashboard:



- 0 Lights OFF
- 1 Position lights ON (the orange lights turn on)
- 2 Low beam ON (the orange lights turn on)

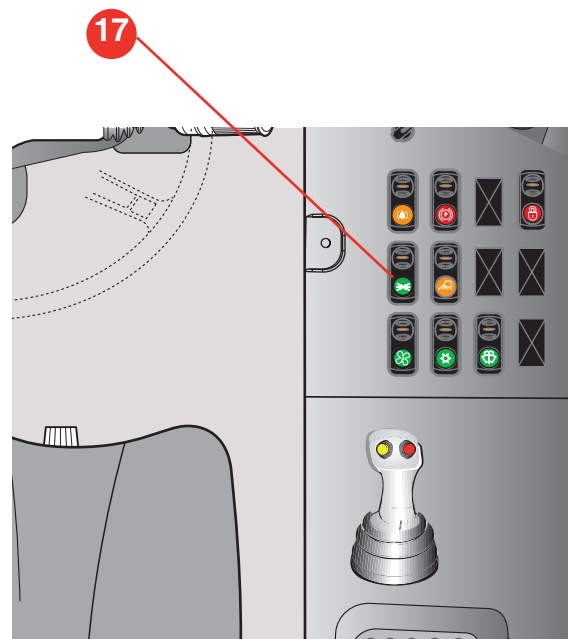

Controls And Instruments

■ Brakes

15 Service Brake Pedal

Gradually step on the brake pedal to decelerate and stop the machine. The pedal operates on the front axle.

Fully depressing the brake pedal causes a reset of the displacement of the power drive pump and makes the braking action more powerful.

18 Parking Brake

The parking brake of negative type engages automatically when the engine is stopped.

When the handler's engine is restarted, pressing the pushbutton switch 18 unlocks the parking brake.

To stop the handler without shutting down the engine, press the pushbutton switch 18 to engage the parking brake and push it once again to disengage the brake.

When starting the engine the light of the pushbutton turns automatically on! When the orange light at the top of the pushbutton and the dashboard warning light are on, the parking brake is engaged.



Never use the parking brake to slow down the machine, unless in an emergency. It may reduce the brake efficiency.

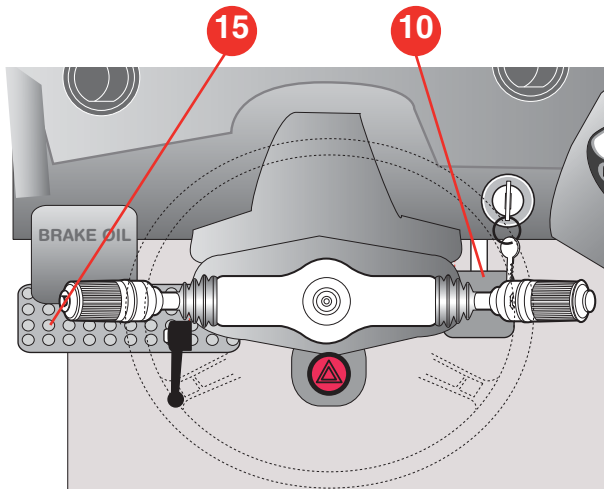

■ Accelerator control

10 Gas Pedal

Its pressure controls the engine rpm and the machine speed. It is fitted with an adjustable stop in the lower part.



When starting the engine the lights of all the pushbuttons turn automatically on!

Only the switching-on of the orange warning light sets on the top of the pushbutton will indicate the activation of the function.

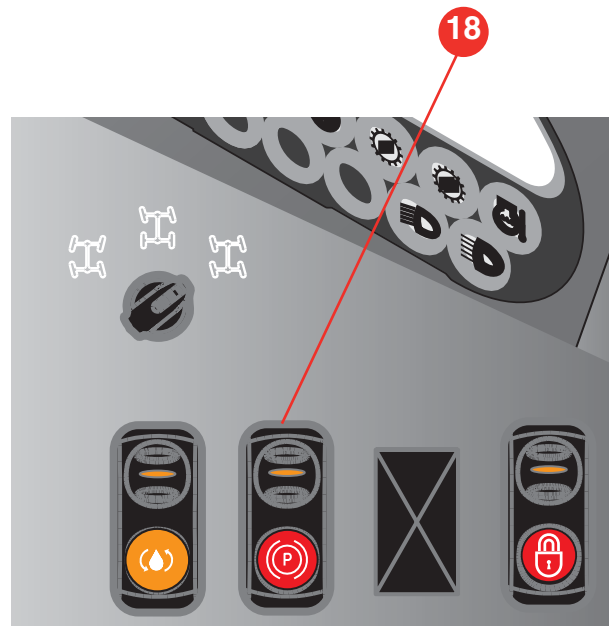

Controls And Instruments

Steering mode selection

20 Steering Mode Switch

Three-position switch for the selection of the steering mode:

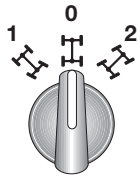

- 1 Four-wheel steering
- 0 Two-wheel steering
- 2 Crab steering

Continuous Oil Flow



Before activate the Continuous Oil Flow function, make sure the connectors of the attachment are coupled.

22 Flow Reversal Button

Pushbutton with orange glass cap, with three stable positions. Press this button to switch the hydraulic circuit feeding the attachments with auxiliary lines to one or another direction.



- 1 Continuous oil flow delivery to the used attachment.
- 0 Joystick flow control (refer to the function selection section of this manual for Joystick Flow Control instructions, page 34).
- 2 Continuous oil flow return to the used attachment.

7 Continuous Oil Flow Potentiometer

By turning the potentiometer clockwise, the flow rate in the circuit feeding the attachments' movement lines is increased.

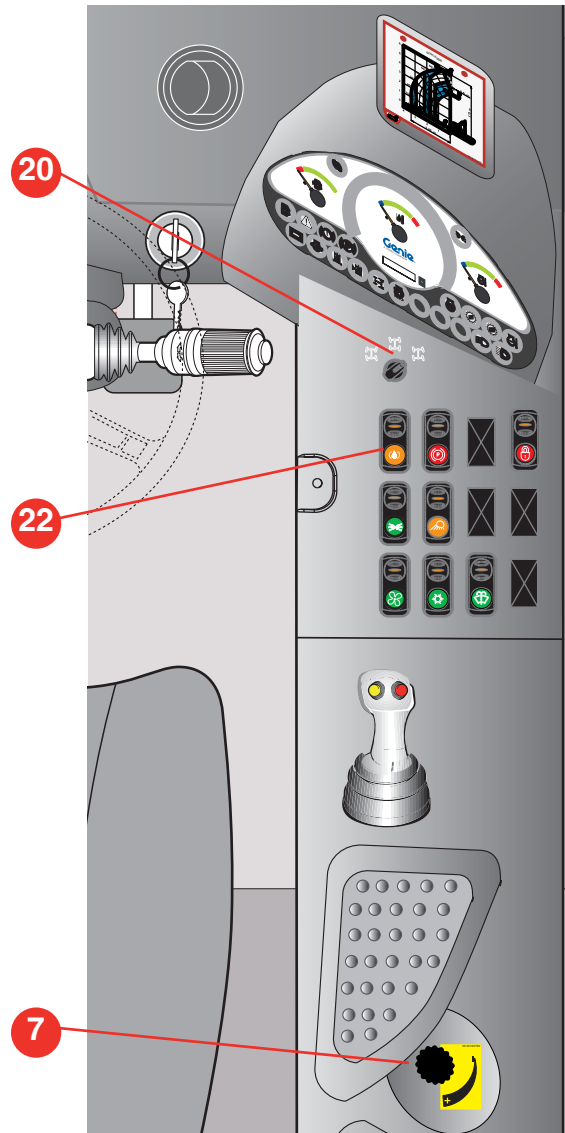

Controls And Instruments

Auxiliary drive controls

8 Hazard Warning Lights Switch (OPTIONAL)

Fitted with on-off position, it switches on the turn signals simultaneously. When the hazard warning light is lit, the relevant switch and the turn signals light start flashing.



28 Windscreen Washer Switch (OPTIONAL)

Two-position switch:



- 0 Washer OFF
- 1 Jet of water on the cab windscreen

23 Cab Heater Fan Switch (OPTIONAL)

Three-position switch:



- 0 Fan OFF
- 1 Low speed
- 2 High speed

29 Work Lights Switch (OPTIONAL)

Three-position switch:



- 0 Lights OFF
- 1 Boom light ON
- 2 Cab and Boom lights ON

27 A/C Switch (OPTIONAL)

Two-position switch:



- 0 A/C OFF
- 1 A/C ON

12 Cab Heater Control Knob (OPTIONAL)

Located at the bottom of the driving seat base, it adjusts the flow of heated air in the cab.

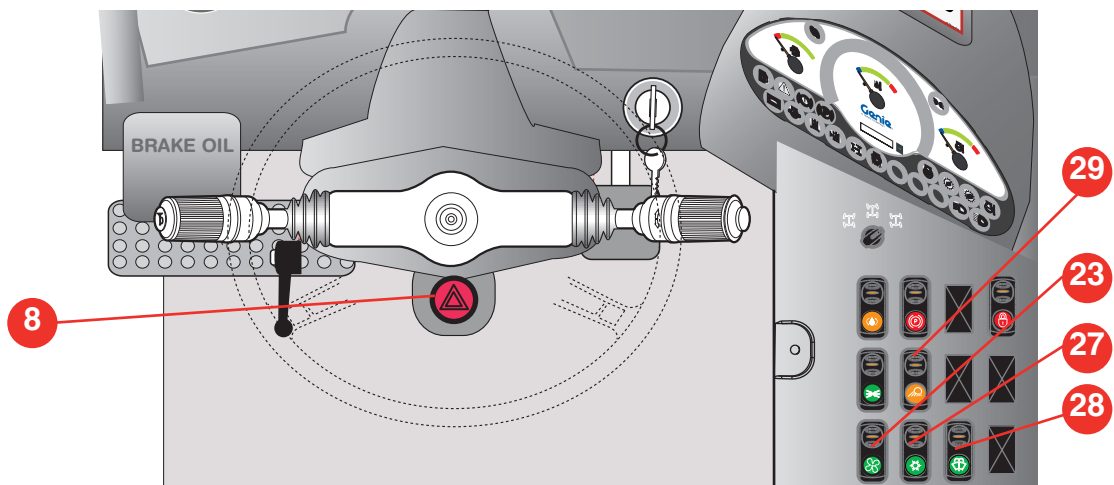
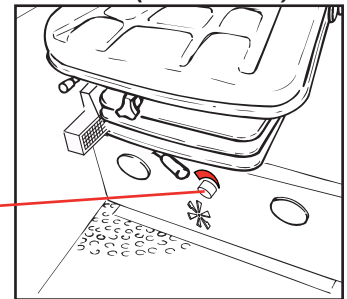

Controls And Instruments

■ Instruments

25 **Engine coolant temperature indicator**

This indicates the engine coolant temperature. If the finger is in the red zone and the warning light comes on, you must stop the machine and find and rectify the problem.

26 **Hydraulic oil temperature indicator**

This indicates the temperature of the hydraulic oil in the tank. If the temperature rises above the permissible value or the red warning light comes on, you must stop the machine and find and rectify the problem.

24 **Fuel gauge**

This indicates the fuel level in the tank. If the fuel level is low (reserve), the relevant warning light comes on.

19 **Hour-meter**

Signals the total operating hours of the machine. Use the hour-meter to gauge the routine maintenance jobs.

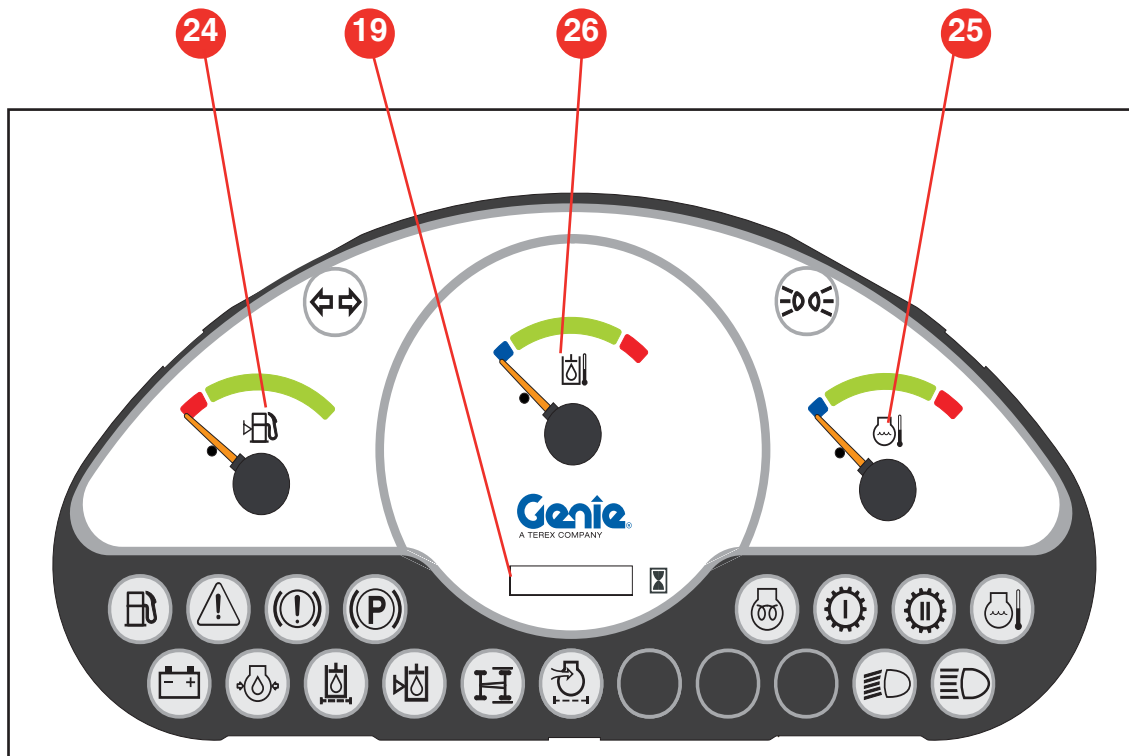

Controls And Instruments

■ Warning lights (ref. 11)

11.1 **Warning light - low battery charge**

Signals a low charge by the alternator.

11.2 **Warning light - low engine oil pressure**

It lights when the engine oil pressure is too low

11.3 **Warning light - air filter restricted**

When this lamp come on, proceed with cleaning or changing the air filter cartridge.

11.4 **Warning light - low brake pressure**

It lights when the pressure of the brake circuit is too low for a correct functioning.

11.5 **Warning light - parking brake engaged**

When ON, this light indicates that the parking brake is engaged.

11.6 **Warning light - high coolant temperature**

This red light comes on to alert to a too high temperature of the cooling medium. Stop the engine and find and rectify the problem.

11.7 **Warning light - high beam**

Blue warning light that signals when high beam is ON.

11.8 **Warning light - hydraulic oil filter clogged**

When this lamp sets to on, immediately change the oil filter on the return line to the tank.

11.9 **Warning light - low hydraulic oil level**

This light comes on to alert to a low level of the hydraulic oil for a correct functioning. Replenish and eliminate the oil leak.

11.10 **General alarm warning light**

This red light comes on to warn of a problem of the machine. Contact the TEREXLIFT Service Centre.

11.11 **Warning light - low fuel level**

If the fuel level is low (reserve), the relevant warning light comes on.

11.12 **OPTIONAL Warning light - rear wheel aligned**

When ON, this light indicates that the rear wheel are aligned.

11.13 **Warning light - glow plugs preheating**

This amber light indicates the pre-heating of the engine glow plugs. Before starting the engine wait for this light to go off. If the light fails to go off, a glow plug could be broken. The machine can be started normally without pre-heating up to a temperature of -12°C.

11.14 **Warning light - low beam**

Green warning light that signals when low beam is ON.

11.15 **Not active**

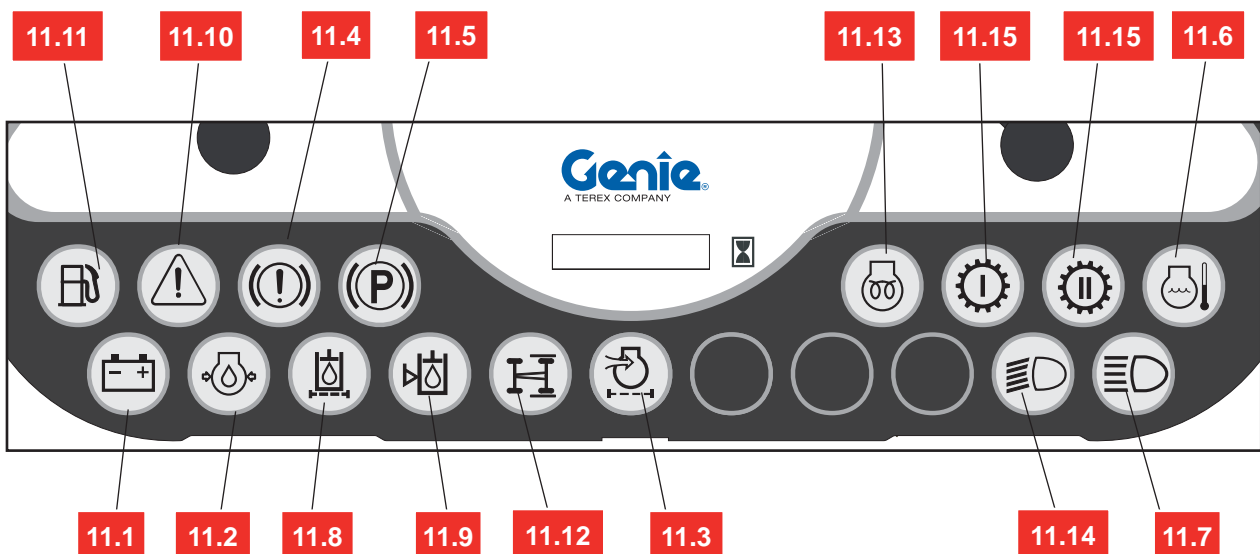

Controls And Instruments

■ CONTROL LEVER

Handlers are equipped with a hydraulically driven servo-controlled lever.

The lever has two pushbuttons: one for coupling/releasing the attachments **3** and the other for pitching the attachment frame forwards/backwards **2**.

Shifting the lever to one of the four directions (right/left, forwards/backwards) moves the boom up and down and the telescope out and in.

Seize the control lever correctly and move it gently.

The motion speed of the actuators depends on the lever position: a small motion results in a slow motion of the actuators; vice versa, a full range motion of the lever corresponds to the max. speed of the actuator.

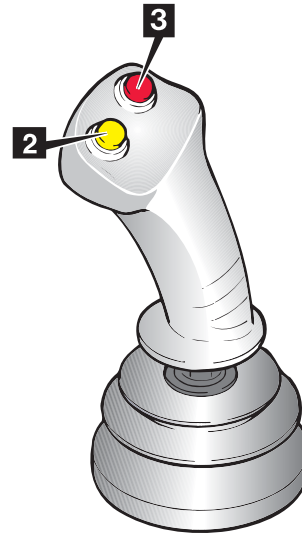

The control lever shall be operated only when correctly seated in the driving place.



Before operating the control lever, make sure that nobody is within the working range of the machine.

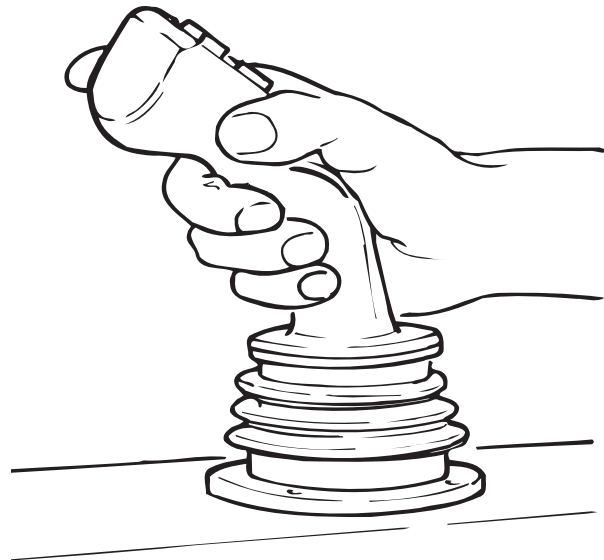

Controls And Instruments

■ Function selection

The lever is enabled to carry out the following motions:

- **Boom lowering/lifting**
shift the control lever to **A** or **B**
- **Boom extraction/retraction**
shift the control lever to **C** or **D**
- **Attachment back/forward tilting**
press button **2** and shift the control lever to **A** or **B**
- **Hydraulic Quick Coupling/Release**
OPTIONAL
 - I. set the Flow Reversal Button to "0" (central position)
 - II. press button **3** together with the dashboard enabling button and shift the lever to **A** or **B**

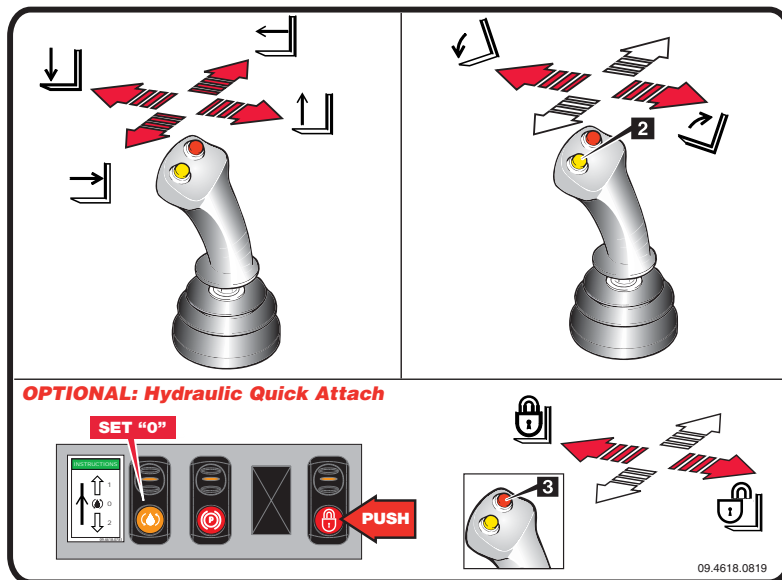
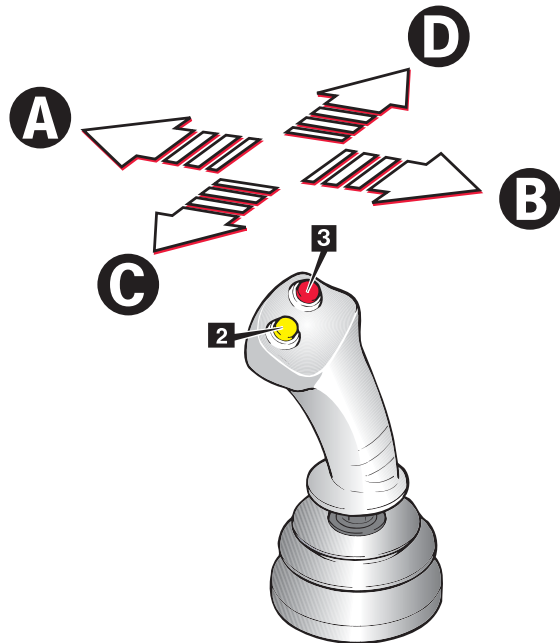

Controls And Instruments

■ Lifting/lowering the boom



Before operating the boom, make sure that nobody is within the working range of the machine.

To lift or lower the boom:

- Smoothly shift the lever to position **B** to lift the boom or to position **A** to lower it.

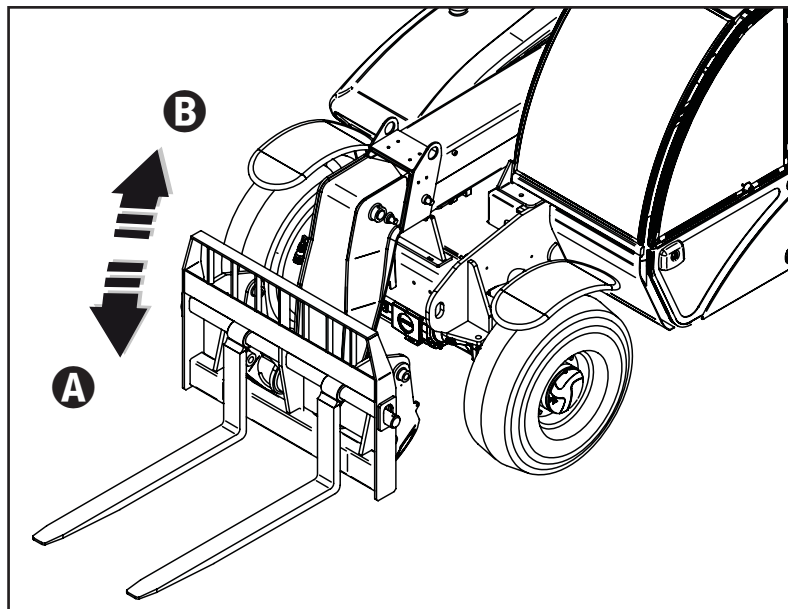
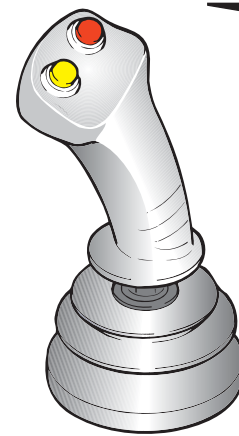
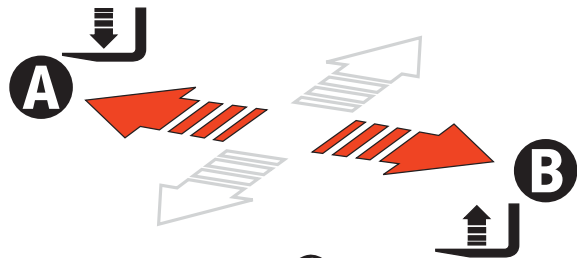

Controls And Instruments

■ Extending/retracting the boom



Before operating the boom, make sure that nobody is within the working range of the machine.

To extend or retract the telescopic elements of the boom:

- Smoothly shift the lever to position **D** to extend the boom or to position **C** to retract it.

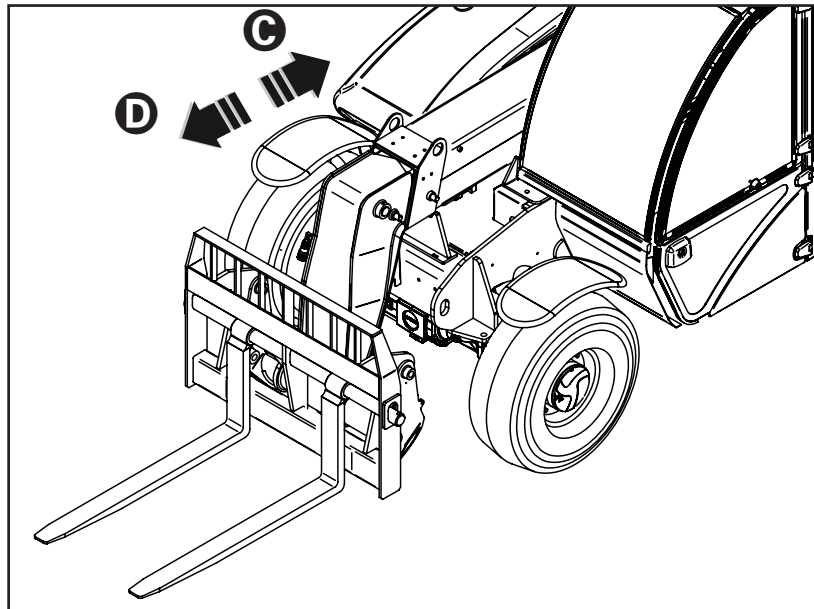
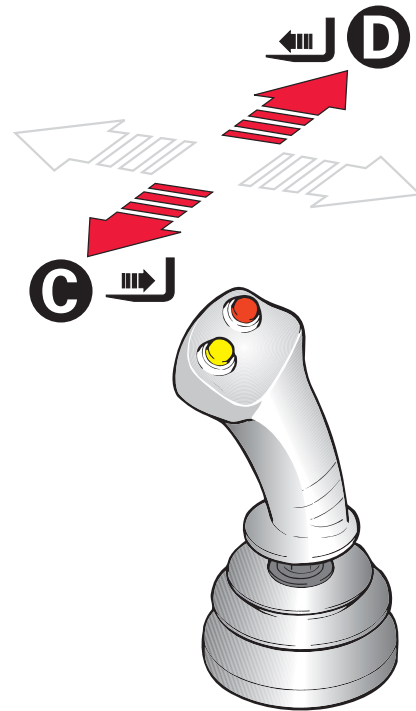

Controls And Instruments

■ Pitching the attachment holding frame forward/back



Before operating the boom, make sure that nobody is within the working range of the machine.

To tilt forward/back the attachment holding frame:

- Press button **2** and shift the lever to position **A** to tilt the frame forwards or to position **B** to tilt it backwards.

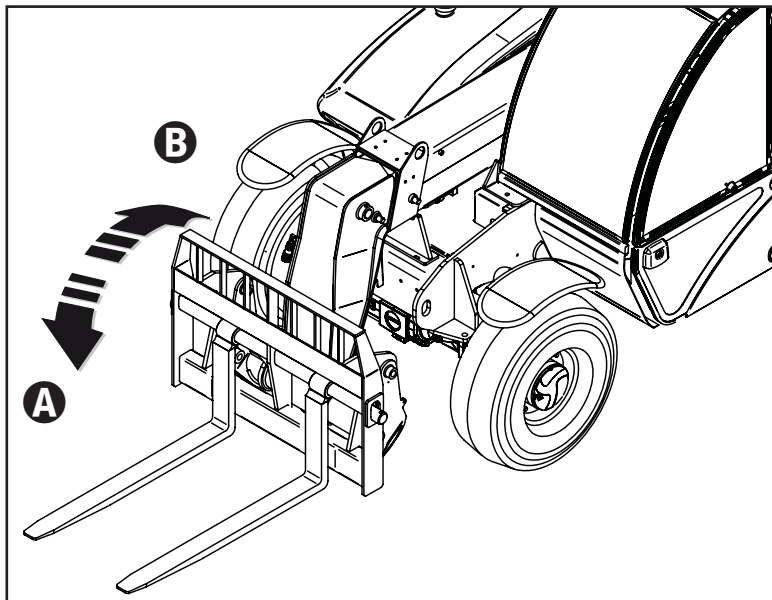
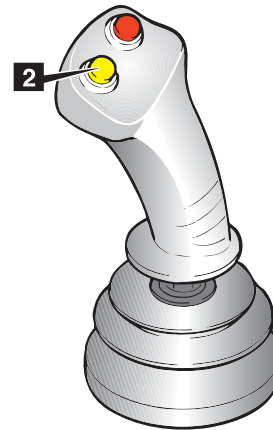
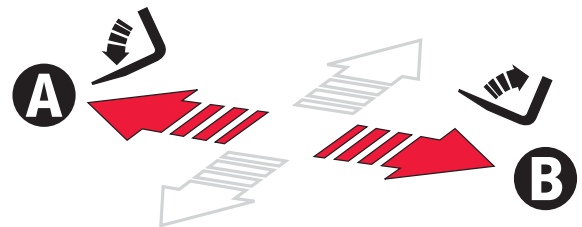

Controls And Instruments

Hydraulic Quick Coupling/Release OPTIONAL



Before operating the boom, make sure that nobody is within the working range of the machine.

To coupling or release the attachment:

- set the Flow Reversal Button to “0” (central position)
- press button 3 together with the dashboard enabling button and smoothly shift the lever to position **A** to coupling or to position **B** to release it.

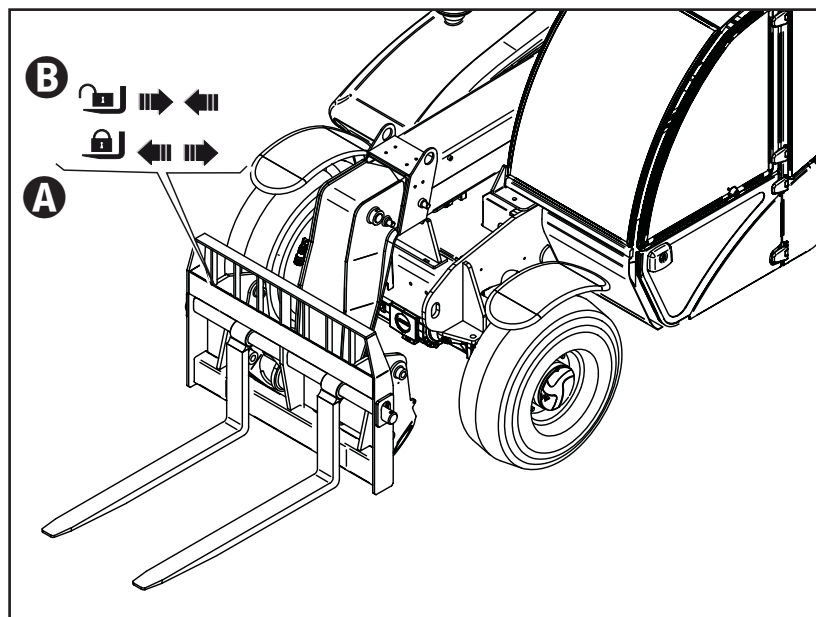
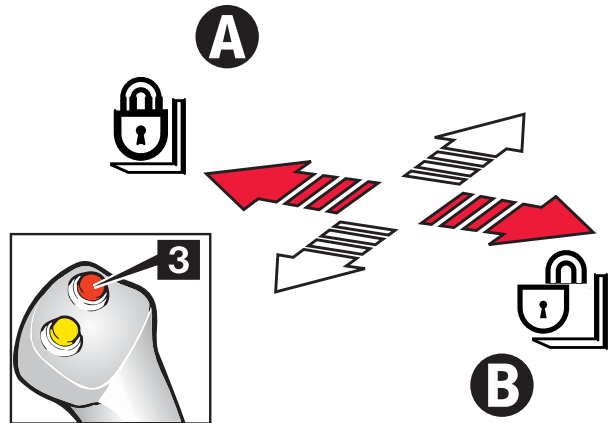

Inspections



Make sure:

- ☑ You learn and practice the principles of safe machine operation contained in this operator's manual.
 - 1 Avoid hazardous situations.
 - 2 **Always perform a pre-operation inspection.**

Know and understand the pre-operation inspection before going on to the next section.

- 3 Always perform function tests prior to use.
- 4 Inspect the workplace.
- 5 Only use the machine as it was intended.

Pre-operation Inspection Fundamentals

It is the responsibility of the operator to perform a pre-operation inspection and routine maintenance.

The pre-operation inspection is a visual inspection performed by the operator prior to each work shift. The inspection is designed to discover if anything is apparently wrong with a machine before the operator performs the function tests.

The pre-operation inspection also serves to determine if routine maintenance procedures are required. Only routine maintenance items specified in this manual may be performed by the operator.

Refer to the list on the next page and check each of the items.

If damage or any unauthorized variation from factory delivered condition is discovered, the machine must be tagged and removed from service.

Repairs to the machine may only be made by a qualified service technician, according to the manufacturer's specifications. After repairs are completed, the operator must perform a pre-operation inspection again before going on to the function tests.

Scheduled maintenance inspections shall be performed by qualified service technicians, according to the manufacturer's specifications.

Inspections

■ PRE-OPERATION INSPECTION

- Make sure the operator's manuals are intact, legible and placed inside the machine.
- Make sure all decals are present and legible. See "**Labels and plates applied on the machine**" chapter.
- Check for engine oil leaks and proper oil level. Top up if necessary. See "**Maintenance**" chapter.
- Check for axle oil leaks and proper oil level. Top up if necessary. See "**Maintenance**" chapter.
- Check for hydraulic oil leaks and proper oil level. Top up if necessary. See "**Maintenance**" chapter.
- Check for engine coolant leaks and proper coolant level. Add coolant if necessary. See "**Maintenance**" chapter.
- Check for battery fluid leaks and proper fluid level. Add distilled water if necessary. See "**Maintenance**" chapter.

Check the following components or zones for damage, missing or wrongly fitted parts or non-authorised modifications:

- electrical components, wiring and electrical cables
- hydraulic hoses, fittings, cylinders and main valves
- fuel and hydraulic oil tanks
- drive pump and motor and transmission axles
- steering system
- braking system
- boom telescopes sliding pads
- clean glasses, lights and rear view mirrors
- engine and relevant components
- limit switches and horn
- lights
- machine ignition control
- nuts, bolts and other fasteners

Check the entire machine for:

- cracks on welds or structural components
- dents or damage to the machine

- * Make sure that all structural and other critical components are present and the relevant fasteners and pins are fitted and properly tightened.
- * After inspection, check that all the compartment covers are in place and latched.



If even one single item is damaged or defective, do not start work. Stop the machine and repair the fault.

Checking the tyres

- * Check the correct inflation of the tyres; see par. "**Tyre inflation**" in the Maintenance section.
- * Make sure that the tyre plies are not cut or worn.



A tyre burst may result in serious injury; never use the machine if tyres are worn, wrongly inflated or damaged.



If the machine shall be used in a marine or equivalent environment, protect it against salt deposits with an adequate treatment against saltiness to prevent rust formation.

Inspections

■ FUNCTION TESTS



The function tests are designed to discover any malfunctions before the machine is put into service. The operator must follow the step-by-step instructions to test all machine functions.

A malfunctioning machine must never be used. If malfunctions are discovered, the machine must be tagged and removed from service. Repairs to the machine may only be made by a qualified service technician, according to the manufacturer's specifications.

After repairs are completed, the operator must perform a pre-operation inspection and function tests again before putting the machine into service.

■ TESTS

- 1 Select a test area that is firm, level and free of obstruction. Be sure there is no load on the forks or attachment.
- 2 Enter the operator's compartment and sit on the seat.
- 3 Fasten the seat belt.
- 4 Adjust the interior rear view mirror and the exterior right hand mirror, if required.
- 5 Be sure the parking brake is on and the transmission control is in neutral.
- 6 Start the engine. See Starting the Engine in the Operating Instructions section.

■ Test the Control Lever

- 7 Using the control lever, momentarily raise the boom, extend the boom, retract the boom and lower the boom.

⦿ Result: All functions should operate smoothly.

- 8 Using the control lever and the yellow button, momentarily tilt the forks up and tilt the forks down.

Result: The function should operate smoothly.

■ Test the Steering

- 9 Push the right side of the steer selector switch to select four-wheel steer.

- 10 Check the steering operation by turning the steering wheel approximately $\frac{1}{4}$ turn in each direction.

⦿ Result: The front wheels should turn in the same direction as the steering wheel. The rear wheels should turn in the opposite direction.

- 11 Straighten the wheels.

- 12 Push the steer selector switch to the middle position to select two-wheel steer.

- 13 Check the steering operation by turning the steering wheel approximately $\frac{1}{4}$ turn in each direction.

⦿ Result: The front wheels should turn in the same direction as the steering wheel. The rear wheels should not turn.

- 14 Straighten the wheels.

- 15 Push the left side of the steer selector switch to select crab steer.

- 16 Check the steering operation by turning the steering wheel approximately $\frac{1}{4}$ turn in each direction.

⦿ Result: The front wheels and rear wheels should turn in the same direction as the steering wheel.

Inspections

■ Test the Transmission and Brakes

17 Be sure the boom is fully lowered and retracted.

18 Step on the service brake pedal.

19 Move the transmission control lever to forward. Slowly let up on the service brake pedal. As soon as the machine starts to move, push the service brake pedal.

- ⦿ Result: The machine should move forward, then come to an abrupt stop.

20 Move the transmission control lever to reverse. Slowly let up on the service brake pedal. As soon as the machine starts to move, push the service brake pedal.

- ⦿ Result: The machine should move in reverse, then come to an abrupt stop. The back-up alarm should sound when the transmission control lever is in reverse.

21 Move the transmission control lever to neutral.

22 Push the top of the parking brake switch.

- ⦿ Result: The red parking brake indicator light should come on, indicating the parking brake is on.

23 Move the transmission control lever forward, then in reverse.

- ⦿ Result: The machine should not move.

24 Push the bottom of the parking brake switch. The parking brake is off when the indicator light is off.

■ Test Auxilliary Hydraulics (if equipped with swing carriage)

25 Using the auxiliary hydraulics switch, momentarily rotate the carriage to the right and to the left.

- ⦿ Result: The function should operate smoothly.

■ Test the Road Lights (optional)

26 Verify that all lights are functional.

■ WORKPLACE INSPECTION



The workplace inspection helps the operator determine if the workplace is suitable for safe machine operation. It should be performed by the operator prior to moving the machine to the workplace.

It is the operator's responsibility to read and remember the workplace hazards, then watch for and avoid them while moving, setting up and operating the machine

Be aware of and avoid the following hazardous situations:

- drop-offs or holes
- bumps, floor obstructions or debris
- sloped surfaces
- unstable or slippery surfaces
- overhead obstructions and high voltage conductors
- hazardous locations
- inadequate surface support to withstand all load forces imposed by the machine
- wind and weather conditions
- the presence of unauthorized personnel
- other possible unsafe conditions

Operating Instructions

This chapter describes some techniques and provides instructions for a safe use of the machine fitted with standard forks. Before using different attachments, thoroughly read the chapter "Optional attachments".



For a safe use of the machine, always check the weight of the loads going to be handled.



Before using the machine, inspect the job site and check for possible hazardous conditions. Make sure that there are no holes, moving banks or debris that may cause you to lose the control of the machine.



Pay the greatest attention when working close to electric lines. Check their position and ensure that no part of the machine operates at less than 6 meters from the power lines.

Operating Instructions

■ ENTERING THE MACHINE

(only for closed cabin)

■ ENTERING THE CAB



Always make sure that your hands and shoe soles are clean and dry before getting into the driving cab. Always face the machine when entering and leaving it and hold to the suitable handles.

The handler cab is equipped with an access door on the left-hand side.

Door opening from outside:

- Insert the key and release lock 1.
- Press the pushbutton 1 and open the door.

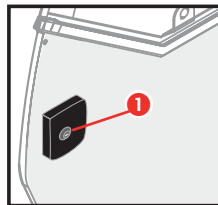

Door closing from inside:

Pull the door with force: it locks automatically.

Door opening from inside:

- Push lever 2 to open the door completely.
- Rotate handle 3 to open the upper section of the door and lock it against the special catch.

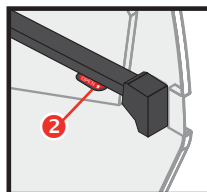

The upper section of the door must be secured to the rear part of the driving cab or latched to the lower section of the same door.

To unlock the door latched in open position:

- Press button 4 to unlock the door from the catch
- Once released, re-close the upper section of the door by means of handle 3.

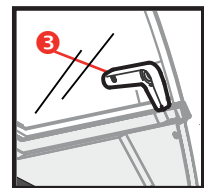
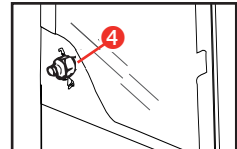

■ Leaving the cab in an emergency

In an emergency, the operator can use the front or the rear window as safety exit-ways.

The rear window has handles for partially opening the glass. Such handles are locked in position by some wing nuts which, if driven out, allow opening the glass completely.

The front window has one, 5, handle which, if turned, enables the operator to pass through.

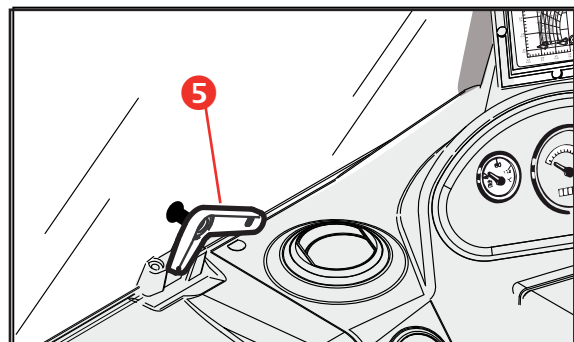

Operating Instructions

■ ADJUSTING THE SEAT

A correct adjustment of the seat ensures the operator a safe and comfortable driving. The handler seat is fitted with devices which allow for the adjustment of the springing, the height and the distance from the controls.

• **Seat distance from the controls**

The seat is equipped with an adjusting device to slide the same seat forward or back with respect to the steering column.

To adjust the seat, pull lever **1** outwards and push the seat to the desired direction. Then release the lever and make sure that the seat locks in position.

• **Springing adjustment (optional)**

Rotate lever **2** clockwise or anticlockwise according to the springing degree required. Rotate clockwise/ anticlockwise to increase/ reduce the seat springing. To reverse this control, pull out and rotate the lever knob by 180°.

• **Height adjustment (optional)**

Turn knob **3** clockwise to lift the seat; turn it counter-clockwise to lower the seat.

In some seats height can be adjusted to three different positions. Lift the seat until you hear the click signalling that the seat is locked in position. To lower the seat, raise to end of stroke to release the mechanism, then release the seat: it will return to the bottom position.



- *The seat is for one person only.*
- *Don't adjust the seat when the machine is moving.*

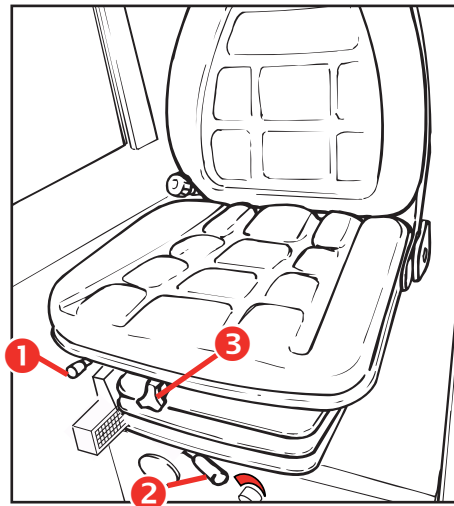

■ FASTENING THE SEAT BELTS

Sit correctly in the driving seat; then:

- The safety belts are equipped with reel retractor. To fasten the belt, pull tab **1** and push it into buckle **2**.
- To release the belt, push button **3** and remove the tab from the buckle.
- Make sure that the buckle is correctly located at the hip point and not on the stomach.
- Operate the end adjusters to reach the length you wish and make sure the buckle is always in the middle.

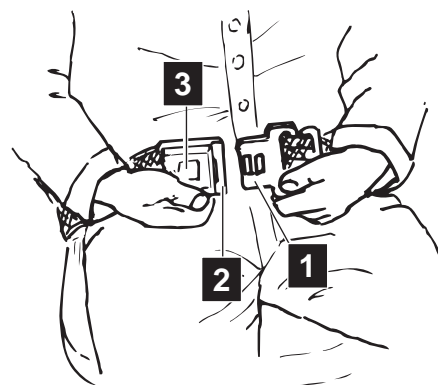

Operating Instructions

■ STEERING COLUMN ANGLE ADJUSTMENT

Both steering column and dashboard can be set to a different angle.

To adjust the steering wheel angle, unlock lever **3** and pull or push the steering wheel to the required position, then re-lock lever **3**.



Before driving the machine, ensure the steering wheel is perfectly clamped.

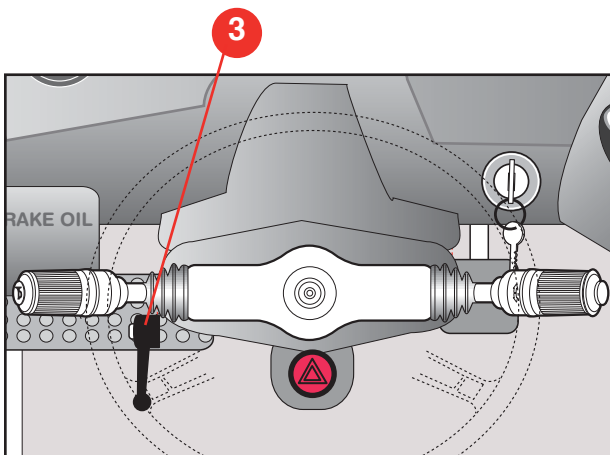

■ ADJUSTING THE REAR VIEW MIRRORS

The machine is fitted with two rear view mirrors:

- The right rear view mirror **2** is located on a special supporting bracket in advanced position and allows checking the area behind the machine, on the right-hand side. To adjust its position, manually rotate the joint it is fitted with.
- The left rear view mirror **3** is placed on the left upper post of the windscreen and allows checking the area behind the machine, on the left-hand side. To adjust its position, manually rotate the joint it is fitted with.

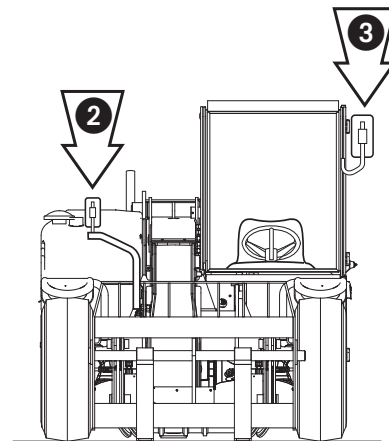

Operating Instructions

■ STARTING THE ENGINE

For the low temperature starting, see paragraph "Low Temperature Starting".

- Engage the parking brake.
- Put the forward/reverse speed selection lever to neutral.
- Step on the gas pedal.
- To start the engine, turn the ignition switch to position 2. Release the switch when the engine starts. If the engine does not start within 20 seconds, release the key and wait at least 2 minutes before attempting again.
- After the start-up, let the engine run at idle for some seconds before engaging a gear; this allows for a gradual warm up of the engine oil and a better lubrication.
- In case of engine jump-starting, remove the booster cables (see following paragraph).

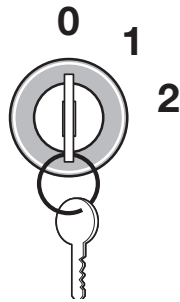

■ JUMP-STARTING THE ENGINE



Do not start the engine using a quick charge booster to avoid any damage to the electronic boards.



When jump-starting the engine through the battery of another machine, make sure that the two vehicles cannot collide to prevent formation of sparks. Batteries give off a flammable gas and sparks may burn it and cause an explosion

Do not smoke when checking the electrolyte level.

Keep any metal object like buckles, watch straps, etc. clear of the battery positive (+) terminal. These elements can short between the terminal and nearby metal work and the operator can get burned.

The booster supply must have the same rated voltage and output of the battery installed on the handler.

To jump-start the engine:

- Turn any users off by the special control levers.
- Put the gear lever to neutral and engage the parking brake.
- Ensure the machine battery **A** is connected to the frame earth, the terminals are well tightened and the electrolyte level is regular.



If the light indicators do not switch off/on when engine is running, immediately stop the machine and find and rectify the fault.



Engine cannot be started if the speed switch is not in the neutral position.



Once it has been started, the engine continues to run even if you leave the driving place. DO NOT LEAVE THE DRIVING PLACE BEFORE HAVING SHUT THE ENGINE DOWN, LOWERED THE BOOM TO THE GROUND, TURNED THE SPEED SWITCH TO THE NEUTRAL POSITION AND ENGAGED THE PARKING BRAKE.

Operating Instructions

- Connect the two batteries as shown in the figure. Connect first the positive terminals of the two batteries, then the negative terminal of the booster supply **B** to the machine frame earth.
- If the booster supply is installed on a second vehicle, make sure that the latter does not touch the handler. **To avoid damage to the electronic instruments of the machine, the engine of the machine where the booster supply is installed, must be stopped.**

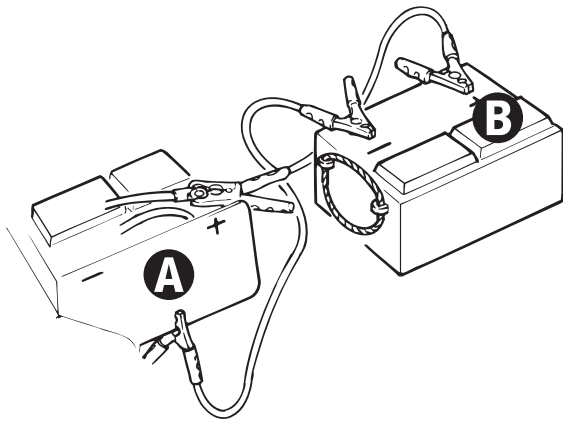

- Turn the ignition key and start the handler.
- Disconnect the cables. Remove first the negative terminal from the frame earth, then from the booster supply. Disconnect the positive terminal from the machine battery, then from the booster supply.

! DANGER

Use only a 12V battery; other devices like battery chargers, etc. may cause an explosion of the battery or result in damage to the electrical system.

■ LOW TEMPERATURE STARTING

In case of cold starting, use an oil with a SAE viscosity adequate to the ambient temperature. Please refer to the engine use and maintenance manual.

The machine is supplied with oil SAE 15W/40.

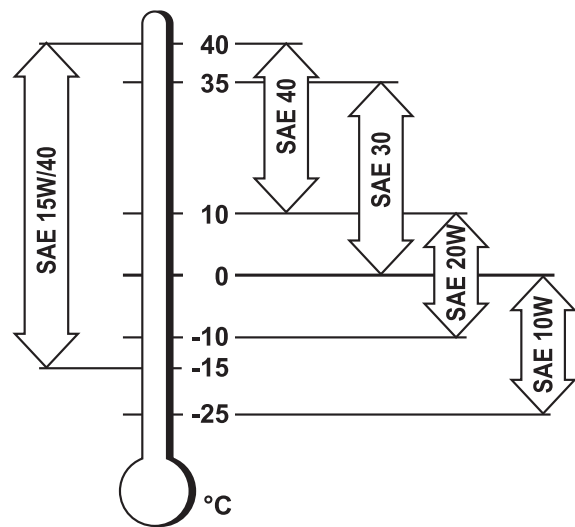

To start the engine from cold, proceed as follows:

- Set the forward/back speed lever to neutral position.
- Turn the ignition switch to the glow plugs preheating position and wait until the relevant warning light **11.13** goes off. Step down on the gas pedal and start the engine by turning the ignition switch. Release the switch as soon as the engine fires.
- Let the engine run at idle for a few seconds before putting a gear; this allows for a gradual warm up of the engine oil and a better lubrication.

Operating Instructions

■ STARTING THE MACHINE

When the engine reaches the running temperature, ensure all parts are in transfer position and the gearbox lever is in neutral. Then, proceed as follows:

- Select the required steering mode.
- Select the required gear (forward or reverse).
- Release the parking brake.
- Slowly step on the gas pedal to start moving off.



Do not operate the forward/reverse gear lever when the machine is running. The machine would reverse the running direction abruptly and you could seriously be injured.

■ STOPPING AND PARKING THE MACHINE

When possible, stop the machine on a dry, level and solid ground. Then:

- Bring the machine to a smooth stop by easing up the gas pedal and stepping down on the brake pedal.
- Set the forward/back speed lever to neutral position.
- Engage the parking brake and ensure its indicator light switches on.
- Release the service brake pedal.
- Rest the attachment coupled to the boom flat on the ground.
- Rotate the ignition key to "0" and remove the key.
- Leave the driving cab and lock the cab door.



Always face the machine when getting off the driving cab; make sure that your hands and shoe soles are clean and dry, and hold to the handholds to prevent falls or slips.



Always engage the parking brake after stopping the machine to prevent possible accidental motions of the vehicle.

Operating Instructions

■ USING THE LOAD CHARTS

The load charts **1** indicates the maximum permissible load in relation to the boom extension and the type of attachment used. To operate under safe conditions, always refer to these charts.

The extension level of the boom can be checked with the help of the letters **(A, B, C, D, E)** painted on the same boom (pos.3), while the actual degrees of inclination of the boom are shown by the angle indicator **2**.

All the load charts are placed into a dedicated holder installed in the right side of the cabin, on the top of the dashboard. The tag **4** located at the top of each load chart represents the type of attachment used.



The load charts applied on the cab windscreen refer to a stationary machine standing on a solid and level ground.

Raise the load some centimetres and check its stability before raising it completely.



The load charts illustrated in this manual are given only as a mere example. To define the payload limits, refer to the load charts applied within the cab of your machine.

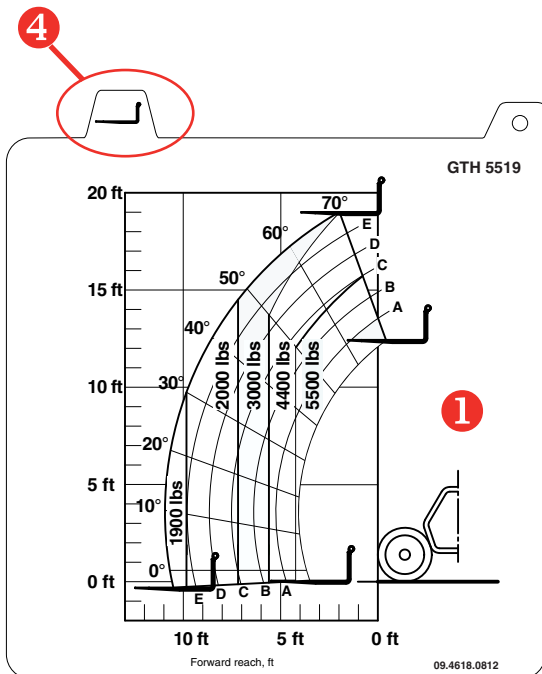
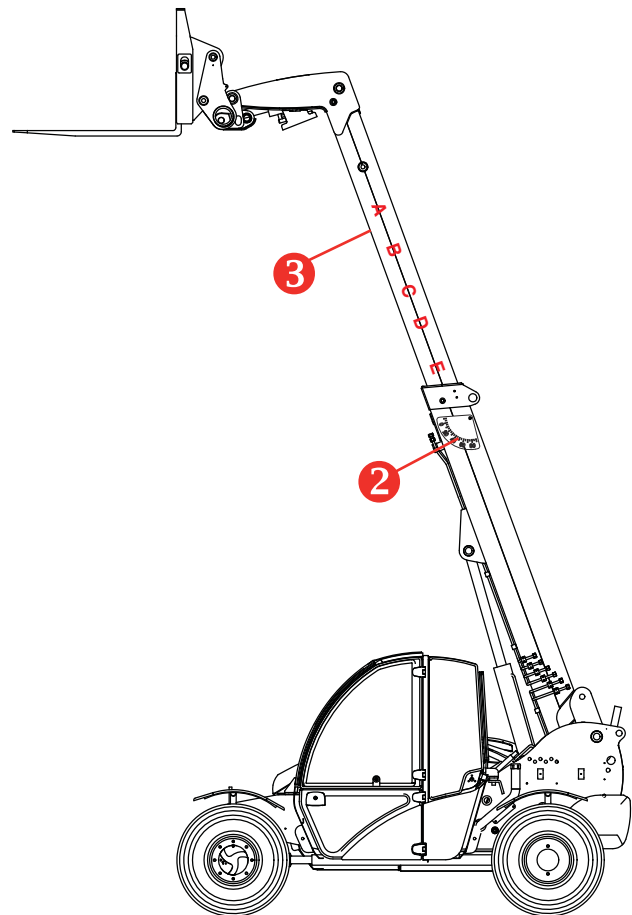

Operating Instructions

■ HANDLING LOADS

■ Adjusting the forks

With FEM forks (optional)

Forks shall be spaced to suit the load going to be handled. For this purpose:

- Lift the clamping lever of the forks.
- Slide the forks to the desired position, then re-lock the lever.

With floating forks

In the case of floating forks:

- Loosen the nut of the locking screws.
- Raise the forks and slide them on the pivot until correct spacing.
- Lock the screws re-tightening the nut.

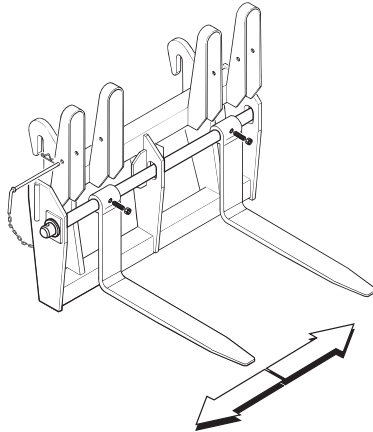

- ***The centre of gravity of the load must always be halfway between the forks.***
- ***Ensure you exactly know the weight of the load before handling it.***
- ***When extending the boom, do not exceed the payload limit.***
- ***Refer to the payload limits given in the load chart applied on the cab windscreen or in the quick user's guide.***
- ***Space the forks as wide as possible to suit the load being handled.***

Operating Instructions

■ WORKING PHASES

When forks are correctly spaced, the handler is ready to use.

Work can be subdivided into three different phases: loading, transfer and unloading.

Loading phase

- Approach the load to the handler perpendicularly and check that the machine is level on the inclinometer.
- Insert the forks under the load and raise the load some centimetres.
- Pitch the forks back to retract the load.

Transfer phase

- Do not start or brake abruptly.
- Drive to the unloading point cautiously and keep the load 8÷12 in from the ground.
- Suit the machine speed to the ground conditions to avoid dangerous jumps, side skids of the vehicle and possible load falls.
- When driving on slopes or ramps, hold the load uphill.



Do not drive on slopes sideways; this wrong manoeuvre is one of the main reasons for accidents due to vehicle overturning.

Unloading phase

- Drive to the unloading point with straight wheels and bring the machine to a smooth stop leaving enough space to operate the boom.
- Put the parking brake and set the transmission to neutral.
- Position the load some centimetres above the desired position and set the forks level.
- Lower the load and make sure it is level.

- Carefully withdraw the forks by operating the boom retraction control and, if necessary, raise or lower the boom as forks come out.
- When the forks are clear of the load, set them to transfer position.
- Release the parking brake and start a new working cycle.

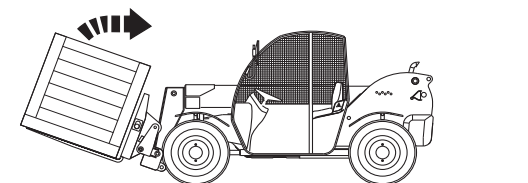
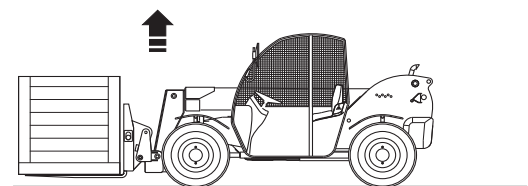
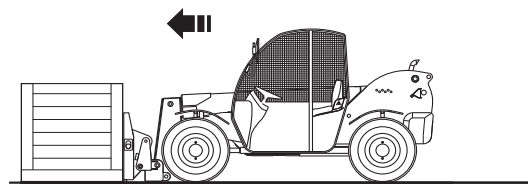
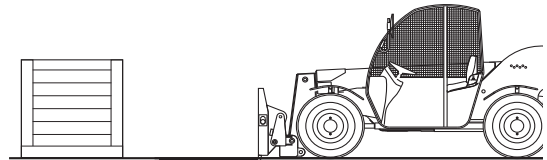

Operating Instructions

■ CHANGING THE ATTACHMENT



Use only attachments directly manufactured or recommended by Terexlift and detailed in the "Optional attachments" section.



After substitution, visually check the attachment is correctly coupled to the boom, before operating the machine. A wrongly coupled attachment may result in damage to persons or things.

Version with MECHANICAL LOCKING

To change an attachment, operate as follows:

- Drive to the place where you will release the mounted attachment (when possible, a solid and sheltered site).
- Disconnect the quick connectors of the attachment (if any).
- Pull out pin 1 locking the attachment after removing the safety split-pin 2 at its end.

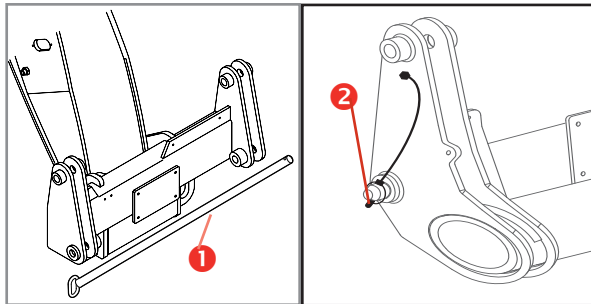

- Rest the attachment flat on the ground.
- Pitch the attachment holding frame forward and lower the boom to release the attachment upper lock.
- Move back with the machine and drive to the new attachment to be coupled.
- Hold the frame pitched forward and hook the upper lock of the new attachment.
- Retract and raise the attachment some centimetres. It will centre automatically on the quick coupling frame.
- Refit pin 1 fixing it with its safety split-pin 2.
- Re-couple the connectors of the attachment (if any).

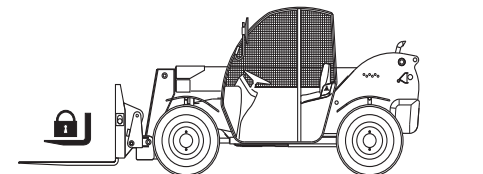
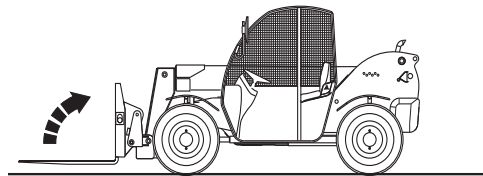
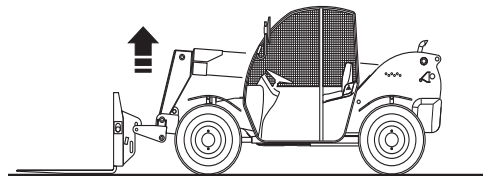
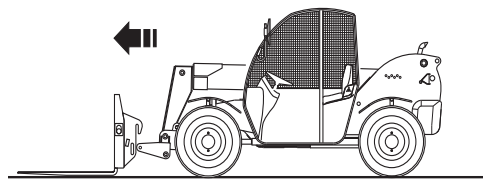
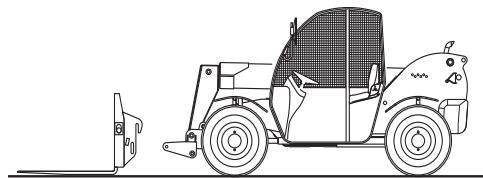

Operating Instructions

Version with HYDRAULIC LOCKING (OPTIONAL)

To change an attachment, operate as follows:

- Drive to the place where you will release the mounted attachment (when possible, a solid and sheltered site).
- Disconnect the quick connectors of the attachment (if any) from the couplings **3**.

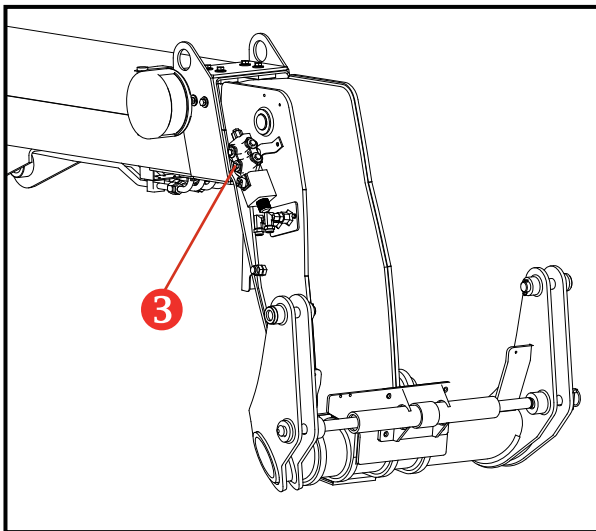

- Rest the attachment flat on the ground.
- Set the Flow Reversal Button to "0" (central position), as shown in the following draft .

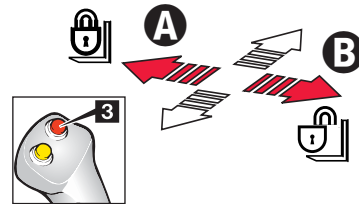

- Free the attachment pressing joystick button **3** together with the dashboard enabling button and smoothly shift the lever to position **B**.
- Pitch the attachment holding frame forward and lower the boom to release the attachment upper lock.
- Move back with the machine and drive to the new attachment to be coupled.
- Hold the frame pitched forward and hook the upper lock of the new attachment.
- Retract and raise the attachment some centimetres. It will centre automatically on the quick coupling frame.
- Coupling the attachment pressing joystick button **3** together with the dashboard enabling button and smoothly shift the lever to position **A**.
- Re-couple the connectors of the attachment (if any).

Transporting The Machine

■ MOVING A DISABLED MACHINE

Tow the machine only when no alternative is possible, since this operation may result in serious damage to the transmission. When possible, repair the machine on site.

When the machine shall absolutely be towed:

- Unlock the parking brake.
- Tow the machine for short distances and at a low speed only (less than 3 mi/h).
- Use a rigid drawbar.
- Select the two-wheel steer.
- Set the forward/back speed lever to neutral position.
- Raise the front wheels of the machine.
- When possible, start the engine and use the hydraulic drive and the braking system.

■ ROAD OR SITE TRANSFER

When travelling on public roads, strictly obey the local or national road traffic regulations.

Besides, take into account the following general precautions:

- Align the rear wheels.
- Cover the teeth of the conventional forks with the special guard; or withdraw the floating forks.

NOTICE

With the floating forks pitched back, do not move the fork pitching cylinder as the machine could suffer from damage.

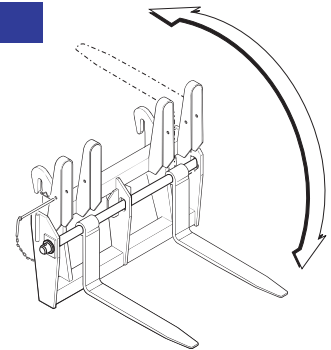

- Retract boom and attachment to transfer position.
- The transfer speed of the vehicle will depend on the engine rpm and the position of the control lever.

NOTICE

Public road circulation is allowed only for transferring an unloaded machine. Do not use the machine to tow trailers.

Transporting The Machine

■ LIFTING THE MACHINE

When the machine shall be lifted, use only means having a suitable capacity. The characteristic data are detailed in the relevant chapter of this manual and on the identification plate.

For the machine lifting, anchor the chains to the special lugs on the machine (marked with the decal below).

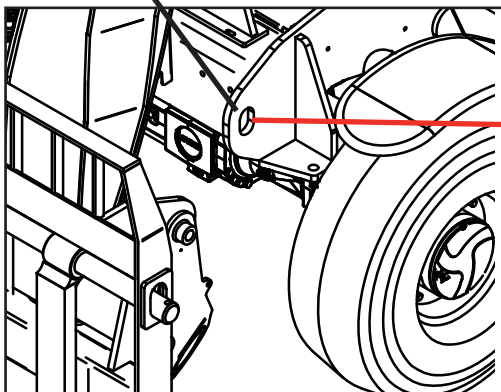
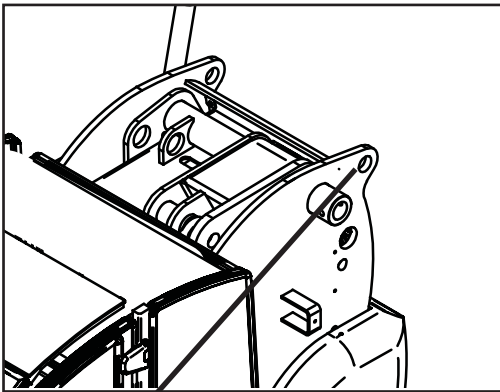

■ TRANSPORTING THE MACHINE ON OTHER VEHICLES

To transport the machine on another vehicle, follow the steps below:

- Ensure ramps are correctly positioned.
- Retract the boom to transfer position.
- Carefully drive the machine onto the transporting vehicle.
- Put the parking brake and rest the attachment flat on the vehicle platform.
- Ensure the overall dimensions do not exceed the allowed limits.
- Shut the engine down and close the driving cab of the machine.
- Secure the machine to the vehicle platform by wheel-chocks.
- Anchor the machine to the transporter's platform by fixing the chains to the special eyebolts **A** on the chassis.

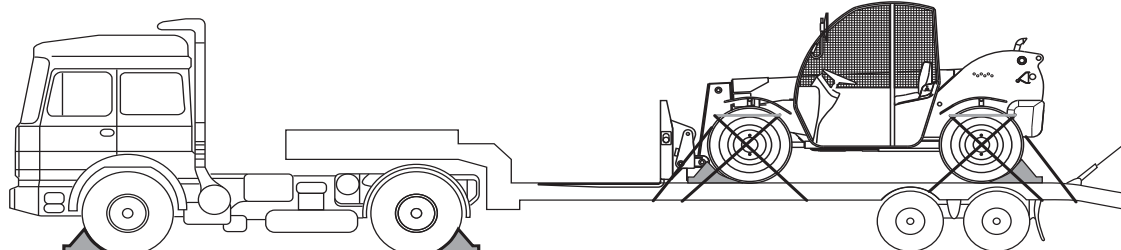
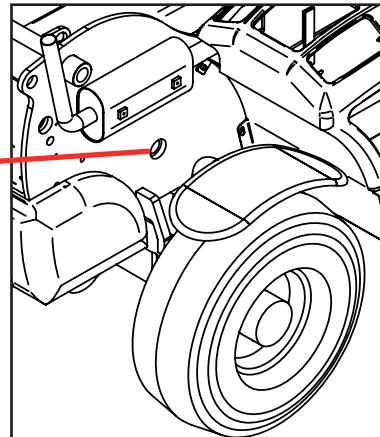

Transporting The Machine

■ PARKING AND STORAGE

■ Short inactivity

Always park the machine in a safe way after a working day, a shift and at night.

Take all precautions to prevent damage to those persons who will approach the machine while stationary:

- Park the machine so that it does not hinder other operations.
- Lower the boom fitted with attachment on the ground.
- Disengage the transmission and put the parking brake.
- Remove the key from the ignition switch and lock the cab door.



Leaving a battery connected can result in shorts and, as a consequence, in a fire.

■ Machine storage

In case of extended inactivity of the machine, follow the above precautions. Additionally:

- Wash the machine thoroughly. For a better cleaning, remove grills and protection casings.
- Carefully dry all machine parts by blowing some compressed air.
- Lubricate the machine thoroughly.
- Do a walk-around inspection and replace any worn or damaged part.
- Re-paint any worn or damaged part.
- Remove the battery, smear its terminals with vaseline and store it in a dry place. Battery can be used for other purposes. Otherwise, periodically check its charge level.
- Refuel the tank to prevent internal oxidation.
- Store the machine in a sheltered and well-ventilated place.
- Start the engine for about 10 minutes at least once a month.
- When weather is particularly cold, empty the radiator.

NOTICE

Always remember that the ordinary maintenance must be carried out even during the machine inactivity. Pay particular attention to the fluid levels and to those parts subject to ageing. Before re-starting the machine, carry out an extraordinary maintenance and carefully check all mechanical, hydraulic and electrical components.

Transporting The Machine

■ CLEANING AND WASHING THE MACHINE

Clean the machine in accordance with the following instructions:

- Remove any oil or grease traces with a dry solvent or a volatile mineral alcohol
- Before assembling a new part, remove any protection product (rust-preventer, grease, wax etc.).
- Remove any trace of rust from metal parts with some emery cloth before smearing the part with a protection product (rust-preventer, paint, oil etc.).



Do not use water at high pressure for washing the machine and especially the main valve, the solenoid valves and electrical parts.

External washing

Before washing the machine, check that the engine is shut down and the doors and windows are closed. Do not, at any times, use fuel to clean the machine. Use water or some steam. In cold climates, dry the locks after washing or smear them with an antifreeze.

Before using the machine again, check its conditions.

Internal washing

Wash the machine interior with some water and a sponge. Do not use water at high pressure. After washing, dry with a clean cloth.

Washing the engine

Before washing the engine, protect the air intake filter to prevent water from entering the circuit.



If the machine shall be used in a marine or equivalent environment, protect it against salt deposits with an adequate treatment against saltiness to prevent rust formation.

■ MACHINE DISPOSAL



At the end of the machine life, call in a specialised firm to dispose of it in compliance with the local or national regulations.

■ Battery disposal



Used lead-acid batteries cannot be disposed of as normal industrial solid wastes. Because of the presence of harmful substances, they must be collected, eliminated and/or recycled in accordance with the laws of the UE.

Used batteries must be kept in a dry and confined place. Make sure the battery is dry and the cell plugs are tight. Place a sign on the battery to warn of not using it. If before disposal the battery is left in the open air, it will be necessary to dry, smear the box and the elements with a coat of grease and tighten the plugs. Do not rest the battery on the ground; it is always advisable to rest it on a pallet and cover it. The disposal of batteries shall be as rapid as possible.

Maintenance

Observe and obey:

- * The operator can only perform the routine maintenance operations envisaged in this manual.
- * Scheduled maintenance procedures shall be completed by qualified technical personnel according to the manufacturer's specifications.



Maintenance symbol legend:

The following symbols are used in this manual to help you understand better the instructions provided. When one or more symbols appear at the beginning of a maintenance procedure, they indicate the following:



Indicates that tools are required to perform the procedure.



Indicates that new parts are required to perform the procedure.



Indicates that a cold engine is required to perform the procedure.



SERVICE INTERVAL

Running-in _____

Ordinary _____

Indicates the time interval for the maintenance jobs expressed in working hours.

INTRODUCTION

A thorough and regular maintenance keeps the machine in a safe and efficient working condition.

For this reason, it is advisable to wash, grease and service the machine properly, especially after having worked under particular conditions (muddy or dusty environments, heavy operations, etc.).

Always ensure all machine components are in good condition. Check for oil leaks or loosening of guards, and make sure that the safety devices are efficient. In case of defects, find and rectify them before using the machine again.

Not respecting the ordinary maintenance schedule of this manual automatically voids TEREXLIFT warranty.

NOTICE

For the engine maintenance, please refer to the specific Operator handbook supplied with the machine.

Maintenance

LUBRICANTS - HEALTH AND SAFETY PRECAUTIONS

Health

A prolonged skin contact with oil can cause irritation. Use rubber gloves and protective goggles. After handling oil, carefully wash your hands with soap and water.

Storage

Always keep lubricants in a closed place, out of the children's reach. Never store lubricants on the open air and without a label indicating their contents.

Disposal

New or exhausted oil is always polluting! Never drain oil on the ground. Store new oil in a suitable warehouse. Pour exhausted oil into cans and deliver them to specialised firms for disposal.

Oil leaks

In case of accidental oil leaks, cover with sand or type-approved granulate. Then scrape off and dispose of it as chemical waste.

First aid

Eyes : In case of accidental contact with the eyes, wash with fresh water. If the irritation persists, seek medical advice.

Intake : In case of oil intake, do not induce vomiting, but seek medical advice.

Skin : In case of a prolonged contact, wash with soap and water.

Fire

In case of fire, use carbon dioxide, dry chemical or foam extinguishers. Do not use water.

Maintenance

ORDINARY MAINTENANCE

A wrong or neglected maintenance can result in possible risks for both operator and bystanders. Make sure maintenance and lubrication are carried out according to the manufacturer's instructions to keep the machine safe and efficient.

The maintenance interventions are based on the machine working hours. Regularly check the hour-meter and keep it in good conditions to define the maintenance intervals correctly. Make sure any defect detected during the maintenance is promptly rectified before using the machine.



All "▲" marked operations must be carried out by a skilled technician.

During the first 10 working hours

1. Check the oil level within reduction gears, power divider and differential gears
2. Regularly check the tightening of the wheel bolts
3. Check the tightening of all bolts and nuts
4. Check the couplings for oil leaks

Every 10 working hours or daily

1. Check the engine oil level
2. Clean the air suction filter
3. Clean the radiator, if necessary
4. Check the hydraulic oil level in the tank
5. Check the greasing of the boom section pads
6. Grease the attachment holding frame
7. Grease all joints of the boom, the rear axle shaft joint, the transmission shafts, the front and rear axles and any equipment of the machine
8. Check the efficiency of the lighting electric system
9. Check the efficiency of braking system and parking brake
10. Check the efficiency of the steering selection system
11. Check the efficiency of the fork balancing system.

Every 50 working hours or weekly

Jobs to be done in addition to those above

1. Check the tension of the alternator belt.
2. Check the tyre inflation.
3. Check the tightening of the wheel nuts.
4. Check the tightening of the Cardan shaft screws.

Every 250 working hours or monthly

Jobs to be done in addition to those above

1. Change the engine oil and relevant filter
2. Check the oil level in the front and rear differential gears and the reducer
3. Check the oil level in the four wheel reduction gears
4. Check the condition of the canister of the engine air filter; renew the canister if necessary
5. Check the clamping of the cableheads to the battery terminals
6. Check the air suction hose between engine and filter
7. Check the cylinder chromium-plated rods
8. Check the hydraulic lines are not worn because of rubbing against the frame or other mechanical components
9. Check the electric cables do not rub against the frame or other mechanical components
10. ▲ Check the wear of the sliding pads of the boom sections.
11. ▲ Adjust the play of the sliding pads of the boom sections.
12. Remove any grease from the boom, then re-grease the sliding parts of the boom sections.
13. Check the level of the battery electrolyte.

Every 3 working months

Jobs to be done in addition to those above

1. Check the efficiency of the block valves.

Maintenance

Every 500 working hours or every six months

Jobs to be done in addition to those above

1. Visually check the smoke quantity evacuated from the engine exhaust.
2. Check the tightening of the engine fixing screws.
3. Check the tightening of the cab fixing screws.
4. Check the backlash between pins and bushings in all joints.
5. Change the hydraulic oil filter in the tank.
6. Have the hydraulic system checked by a skilled technician.
7. Change the main cartridge of the engine air filter.
8. Change the hydraulic oil filter of the transmission
9. Clean or replace, if necessary, the air filter in the cab.

Every 500 working hours or yearly

Jobs to be done in addition to those above

1. Change the engine oil and renew the fuel filter.

Every 1000 working hours or yearly

Jobs to be done in addition to those above

1. Change the oil in the front and rear differential units and in the power divider
2. Change the oil in the four wheel reduction gears.
3. Change the hydraulic oil.

■ OIL CHANGE SCHEDULE

	Job	Operating hours *	Service interval *	Oil type
Engine	Oil level check	10	daily	SHELL RIMULA 15W-40 (API CH-4/CG-4/CF-4/CF; ACEA E3; MB228.3)
	First change	500	-	
	Subsequent changes	500	yearly	
Axles and power divider	Oil level check	250	monthly	FUCHS TITAN GEAR LS 85 W-90 API GL-5 LS / GL-5
	First change	-	-	
	Subsequent changes	1000	yearly	
Hydraulic oil	Oil level check	10	daily	SHELL TELLUS T 46 DENISON HF-1, DIN 51524 part 2 & 3
	First change	-	-	
	Subsequent changes	1000	yearly	

* whichever occurs first.

Maintenance

MAINTENANCE INTERVENTIONS

WARNING

All maintenance interventions must be carried out with engine stopped, parking brake engaged, working attachments flat on the ground and gear lever in neutral.

WARNING

When raising a component for maintenance purposes, secure it in a safe way before any maintenance intervention.

WARNING

Any intervention on the hydraulic circuit must be carried out by skilled personnel. The hydraulic circuit of this machine is fitted with pressure accumulators. You and others could be seriously injured if accumulators are not completely depressurised. For this purpose, shut the engine down and step on the brake pedal 8÷10 times.

WARNING

Before any operation on hydraulic lines or components, make sure there is no residual pressure. For this purpose, stop the engine, engage the parking brake and operate the control levers of the main valve in both working directions (alternately) to depressurise the hydraulic circuit.

CAUTION

High pressure lines must be replaced by qualified personnel only.

Any foreign matters entering the closed circuit may result in a sudden deterioration of the transmission.

CAUTION

The qualified staff charged with the maintenance of the hydraulic circuit must clean all areas around with care before any intervention.

PROTECT THE ENVIRONMENT

The handling and disposing of used oils can be ruled by local or national regulations. Address to authorised centres.

Maintenance

■ ACCESS TO THE ENGINE COMPARTMENT

For any operation within the engine compartment, open the protection bonnet.

Hood is equipped with lock & key and a supporting rod that holds it in position.

From the engine compartment, you get access to:

- Thermal engine **A**
- Engine air filter **B**
- Radiator fluid compensation cup **C**
- Battery **D**

To get access to the engine compartment:

- Shut the engine down and put the parking brake.
- Unlock and raise the hatch with handle.



Take all precautions when approaching the engine compartment. Some parts of the engine may be very hot. Always use protective gloves.



Deutz version

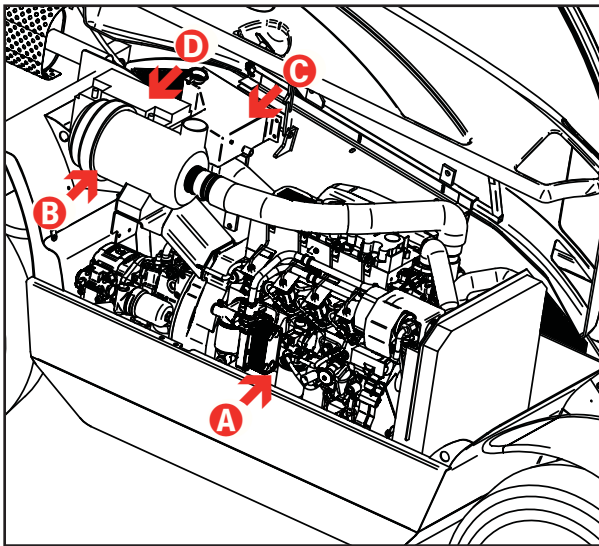

Perkins version

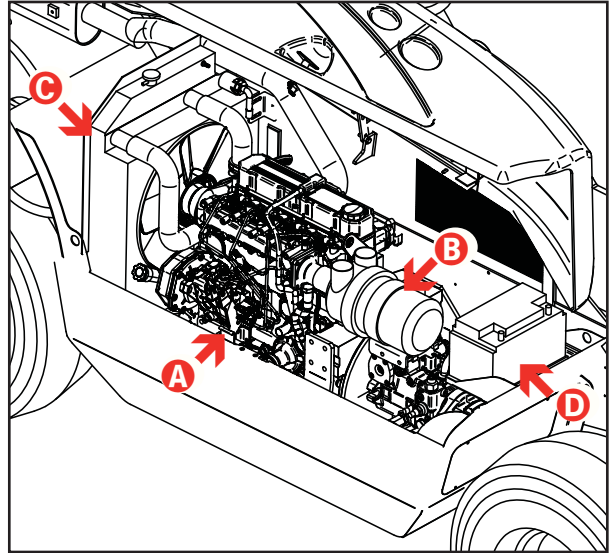

Maintenance

ENGINE AIR FILTER



Clean the engine air filter and replace the elements, when necessary.

- 1 Cleaning and changing the outer element:
 - Shut the engine down and engage the parking brake.
 - Unlatch the fasteners **A** and remove cover **B**
 - Pull out the filter cartridge **C**.
 - Clean the filter bowl.
 - Dry clean the cartridge (at max. 6 bar pressure) and direct the air jet from inside to outside.
 - Check the filter element for cracks by introducing a lamp inside.
 - Refit the cartridge and make sure it is properly positioned.
 - Close cover **B** and lock in place with fasteners **A**.

CAUTION

As soon as the warning lamp 11.3 on the cab dashboard switches on, replace the outer element.
Never wash the cartridge with water or solvents.

2 Changing the internal element

- See step 1 for removing the outer element.
- Extract the internal cartridge **D**.
- Clean the filter bowl.
- Mount the new element and make sure it is correctly positioned.
- Fit the main filter and the cap as described in point 1.

CAUTION

The inner element should be replaced every two times the outer element is replaced.
Never wash the cartridge with water or solvents.

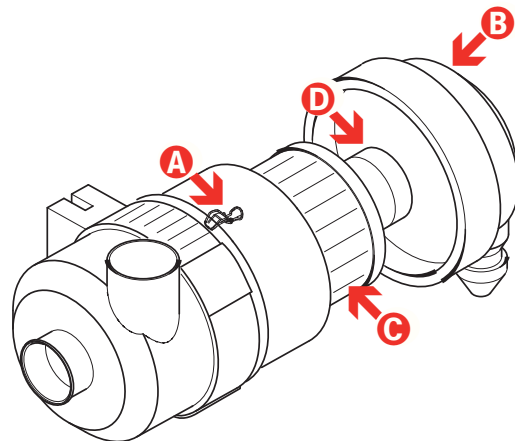

SERVICE INTERVAL	
Running-in	None
Cleaning	Every 10 hours
Outer element change	Every 500 hours
Inner element change	Every 1000 hours

Maintenance

ENGINE COOLING SYSTEM



DANGER

When the coolant is hot, the cooling system is under pressure. With warm engine, loosen the radiator plug slowly and carefully, without removing it, to drain the pressure. Use protection gloves and keep your face at a safe distance.

- Weekly check the coolant level through the level window **C**, before starting working (when fluid is cold).
- When necessary, add clean water or an antifreeze mixture through cap **A**.
- Change the antifreeze mixture every two years. To drain the antifreeze:
 - Let the engine cool down
 - Unscrew the plug **B** at the bottom of the radiator or disconnect the rubber hose, if no plug is present. Allow the coolant to flow out into a special container.
 - Refit the hose and pour new antifreeze (50% water-antifreeze). This proportion will provide protection up to -37°F.
- Daily clean the radiator grille using a brush with hard bristles or compressed air at a max pressure of 6 bar.

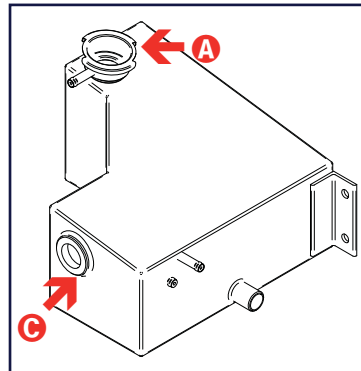

Deutz version

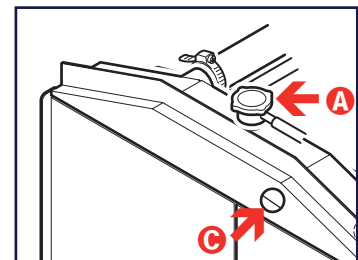

Perkins version

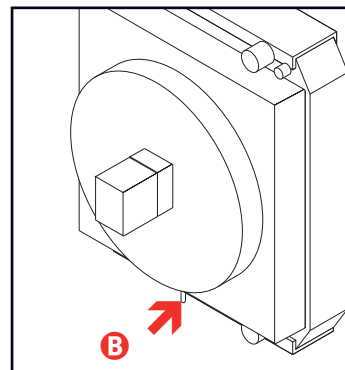

Both versions

On delivery, the machine is filled with a cooling mixture consisting of 50% water and 50% anti-freeze.

TEREX PRO COOL Protection against boiling / freezing		
Product %	Freezing point	Boiling point
33	1.5°F	253°F
40	-11°F	259°F
50	-33°F	262°F
70	-88°F	275°F

SERVICE INTERVAL

Running-in _____ None

Ordinary _____ **Every 50 hours**

Maintenance

■ CHECKING THE OIL LEVEL IN THE TANK



Fine jets of hydraulic oil under pressure can penetrate the skin. Do not use your fingers, but a piece of cardboard to detect oil leaks.

Visually check the hydraulic oil level through level **A** located on the reservoir and visible through the slot on the right side of the chassis.

When necessary, add new oil through filler **B**.

 **SERVICE INTERVAL**

Running-in _____ Within the first **10** hours

Ordinary _____ Every **50** hours



The handling and disposing of used oils can be ruled by local or national regulations. Address to authorised centres.

■ CHANGING THE HYDRAULIC OIL



To change the hydraulic oil, proceed as follows:

- 1 Stop the machine on a level ground and make sure the parking brake is engaged.
- 2 Release the pressure from the hydraulic circuit.
- 3 Place a container of suitable size under the drain plug, placed in the lower part of the reservoir, and collect any oil leaks.
- 4 Remove the drain plug and allow oil to flow out into the container.
- 5 Remove the inspection cover of tank **C**.
- 6 Carefully wash the tank with Diesel oil and blow a jet of compressed air.
- 7 Refit the drain plug and the inspection cover.
- 8 Add new oil by making sure that it matches the recommended type until it is level with **A**.

 **SERVICE INTERVAL**

Running-in _____ None

Ordinary _____ Every **1000** hours

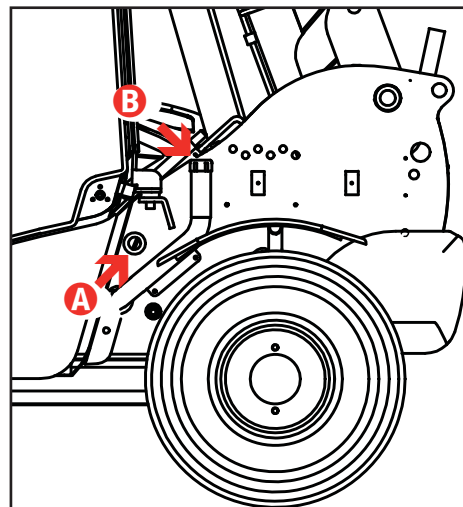
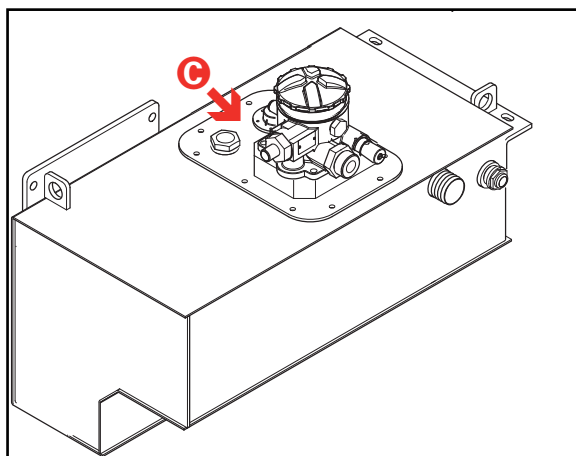

Maintenance

■ CHANGING THE OIL FILTER CARTRIDGE



To change the hydraulic oil filter element, proceed as follows:

- 1 Stop the machine on a level ground and engage the parking brake.
- 2 Place a container of suitable size under the filter to collect any oil leaks.
- 3 Remove the filter cover to get access to the filter element **A**.
- 4 Change the filter element, then, before fitting a new one, thoroughly clean and grease both seat and gasket.
- 5 Refit and tighten the filter cover.

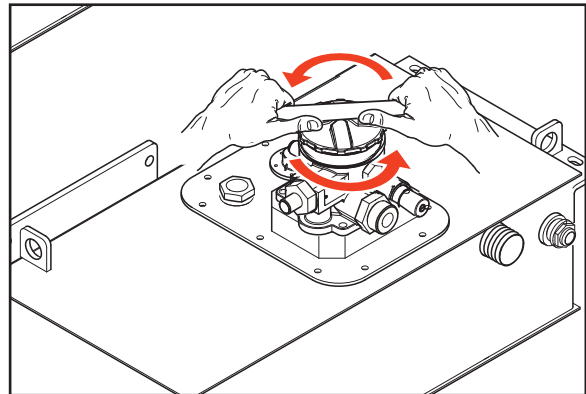

CAUTION

The hydraulic oil filter cartridge shall be replaced as soon as the clogging indicator light on the control board comes on (see par. Controls and instruments).

CAUTION

Hydraulic oil filter canisters cannot be cleaned or washed and refitted. They must be replaced with new ones of the type recommended by the manufacturer.

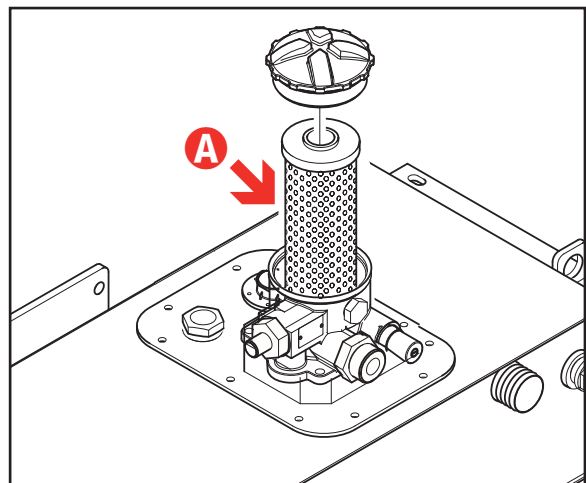

PROTECT THE ENVIRONMENT

The handling and disposing of used oils may be ruled by local or national regulations. Address to authorised centres.



SERVICE INTERVAL

Running-in _____ None

Ordinary _____ Every **500** hours

Maintenance

■ CAB AIR FILTER (ONLY FOR CLOSED CABIN)



Every six months clean the air filter in the cab. Replace the cartridge if the filtering cloth is damaged.

1 *Cleaning and changing the cartridge:*

- Shut the engine down and engage the parking brake.
- Pull filter **A** out of the housing accessible from the inside of the cab.
- Clean the filter bowl.
- Clean the filter cartridge by beating it against a piece of wood. Replace the cartridge if damaged.

CAUTION

Paper filters must never be cleaned using compressed air or washed with water and/or solvents.

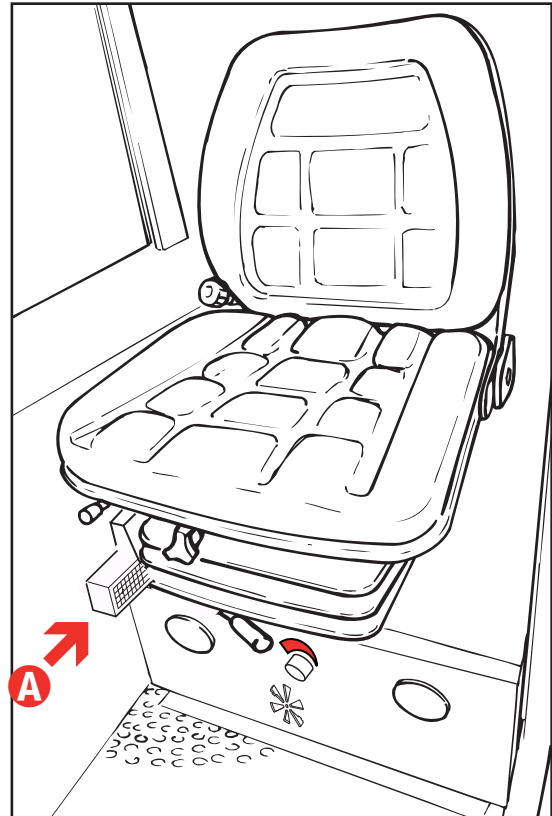

Maintenance

■ OIL LEVEL IN THE DIFFERENTIAL GEARS

To check the oil level in the front and rear differential gears:

- Stop the machine on a level ground and engage the parking brake.
- Loosen level plug ③ and check if oil is level with the hole.
- If necessary, top-up through hole ① until oil comes out from hole ③.
- Refit and tighten plugs ③ and ①.

To change the oil:

- Place a container of suitable size under drain plug ②.
- Loosen the drain plug, the level plug ③ and the filler ① and allow oil to flow out from the reduction gear.
- Refit and tighten drain plug ②.
- Add new oil through the filler until it is level with hole ①.
- Refit and tighten plugs ③ and ①.

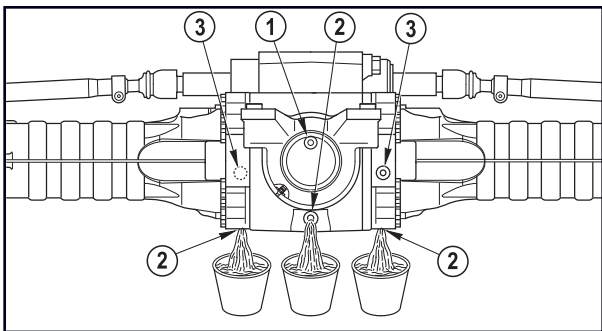
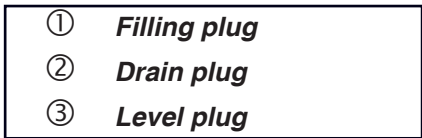

 **SERVICE INTERVAL**
 Running-in _____ Within the first **10** hours
 Ordinary _____ Every **250** hours

■ OIL LEVEL IN THE (front/rear) WHEEL REDUCTION GEARS



To check the oil level within the wheel reduction gears:

- Stop the machine on a level ground and ensure the parking brake is engaged and plug finds on the horizontal axis.
- Clean the plug all around, then remove it and check if oil is level with the hole.
- If necessary, add new oil through hole until it is level.
- Refit the plug.

To change the oil:

- Stop the machine and ensure the plug is oriented along the vertical axis.
- Place a container of suitable size under the reduction gear plug.
- Unscrew plug and drain any oil from the reduction gear.
- Rotate the wheel by 90° until the plug finds again on the horizontal axis.
- Add new oil through hole ①.
- Refit and tighten plug.

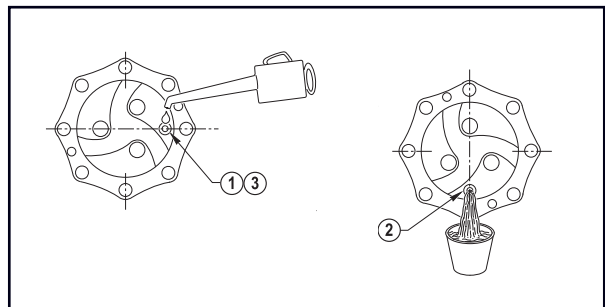

 **SERVICE INTERVAL**
 Running-in _____ Within the first **10** hours
 Ordinary _____ Every **250** hours

Maintenance

■ OIL LEVEL IN THE POWER DIVIDER GEARBOX



To check the oil level in the power divider gearbox:

- Stop the machine on a level ground and make sure the parking brake is engaged.
- Clean level plug ① all around.
- Remove the plug and check if oil is level with the hole.
- When necessary, add new oil through plug ① until it is level with the hole.
- Refit and tighten the plug.

To change the oil:

- Place a container of suitable size under the drain plug.
- Remove the plug ①.
- Remove the drain plug ② and empty the power divider gearbox.
- Refit and tighten the drain plug ②.
- Pour in new oil through the filler ① placed at the top of the reduction gear of the power divider. Stop when oil is level with hole ①.
- Refit and tighten plug ①.

- | | |
|---|---------------------|
| ① | Filling plug |
| ② | Drain plug |

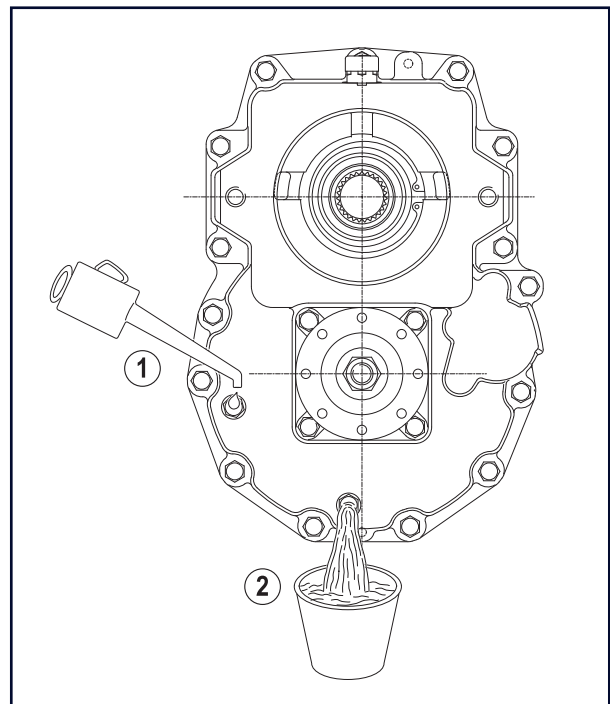



SERVICE INTERVAL

Running-in _____ **Within the first 10 hours**

Ordinary _____ **Every 250 hours**

Maintenance

■ GREASING



CAUTION

Before injecting grease into the greasers, thoroughly clean them to avoid that mud, dust or other matters can mix with the lubricant and reduce or annihilate the lubrication effect. Remove any old grease with a degreaser from the telescopes before smearing them with new grease.

Regularly grease the machine to grant it efficient conditions and a long life.

By means of a pump, inject grease into the special greasers.

As the fresh grease comes out, stop the operation. The greasing points are shown in the following figures:

- the symbol  represents the points to be greased by a pump
- the symbol  represents the points to be greased by a brush.

CAUTION

Use only PTFE INTERFLON FIN GREASE LS 2 to lubricate the sliding parts of the telescopic section. Observe the following schedule:

- *After the first 50 operating hours (1 week)*
- *After the first 250 operating hours (1 month)*
- *Every 1000 operating hours (6 months)*

Remove any old grease from the boom and smear the sliding area of the blocks with a thin coat of grease.

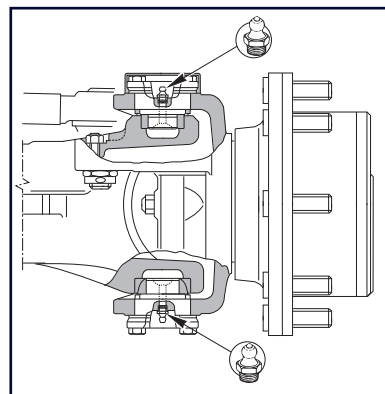



SERVICE INTERVAL

Running-in _____ None

Ordinary _____ **Every 10 hours**

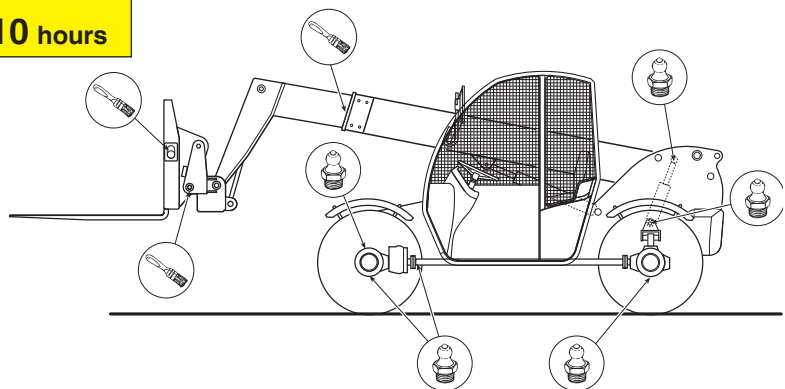

Maintenance

■ TYRES AND WHEELS



Over-inflated tyres can burst.



Overheated can burst. Do not weld the wheel rims. For any repair work, call in a qualified technician.

Always use tyres having the dimensions indicated in the vehicle registration card.

	SERVICE INTERVAL
Running-in _____	Within the first 10 hours
Ordinary _____	Every 250 hours

■ BRAKES

For any intervention on the braking system (adjustment and/or substitution of the brake discs) address to the TEREXLIFT Technical Assistance Service or the nearest TEREXLIFT authorised workshop.

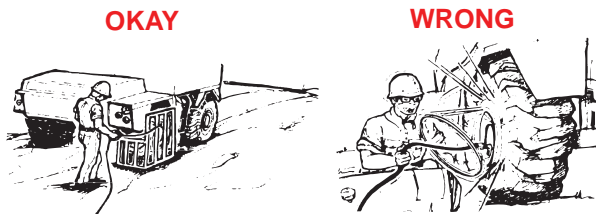

For the tyre inflation or substitution, please refer to the table below:

	GTH 5519
Dimensions (front and rear)	12-16.5
P.R. (or load index)	10 pr
Rim	9.75x16.5
Wheel disc	8 holes DIN 70361
Pressure bar/Psi	4.5/65

On new machines, and when a wheel has been disassembled or replaced, check the nut torque of the wheels every 2 hours until they stay correct.
Torque: 295 lbs/ft.

Maintenance

SHAFTING ALIGNMENT

During operation, the alignment of the front and rear axles of the machine can be subject to variations. This can depend on an oil blow-by from the steering control circuit, or on a steering of both axles when front and rear wheels are not perfectly aligned.

To fix this problem, rather than checking the alignment visually, follow the procedure below:

- 1) Move to a solid and level ground
- 2) Set the steering selection switch **27** to "four-wheel steer" (pos. **1**)
- 3) Rotate the steering up to its stop (either to the right or to the left)
- 4) Set the steering selection switch to "two-wheel steer" (pos. **0**)
- 5) Rotate the steering up to its stop (turn in the same direction as above)
- 6) Reset the steering selection switch to "four-wheel steer" (pos. **1**)
- 7) Rotate the steering (to the side opposite to point **3**) so that the rear axle reaches its stop
- 8) Reset the steering selection switch to "two-wheel steer" (pos. **0**)
- 9) Rotate the steering (to the same side as in point **7**) so that the front axle reaches its stop
- 10) Reset the steering selection switch to "four-wheel steer" (pos. **1**)

Now the wheels should be re-aligned.

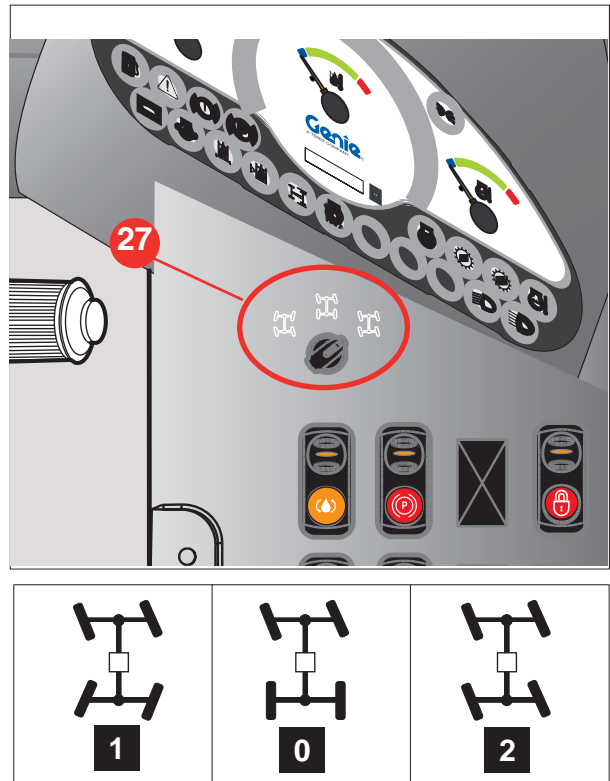

	SERVICE INTERVAL
Running-in _____	None
Ordinary _____	When necessary

Maintenance

■ ADJUSTING THE SLIDING PADS OF THE BOOM SECTIONS



Any boom section is fitted with adjustable pads located on the four sides of the profile. These pads are secured to both fixed and mobile part of every section.

All pads can be adjusted by the special shims supplied by TEREHLIFT upon demand.

Adjusting the pads:

- Remove or loosen the screws fixing the pads in relation to type of shims used (with or without slots).
- Fit the necessary amount of shims.
- If the residual thickness of the pad is insufficient or near the maximum wearing limit, renew the pad.
- Tighten the screws fixing the pads at the recommended torque (see below). Use a dynamometric wrench.

Tightening torques of the pad screws in relation to the screw diameter

Screws M10	Idf-ft 22
Screws M14	Idf-ft 37

Tightening torques higher than those recommended can cause the break of the pad or of the locking threaded bush.

CAUTION

Pads must compulsorily be replaced if the residual thickness of the plastic layer with respect to the iron bush fixing the block is equal or inferior to 1 mm.

SERVICE INTERVAL

Running-in _____ None

Ordinary _____ When necessary

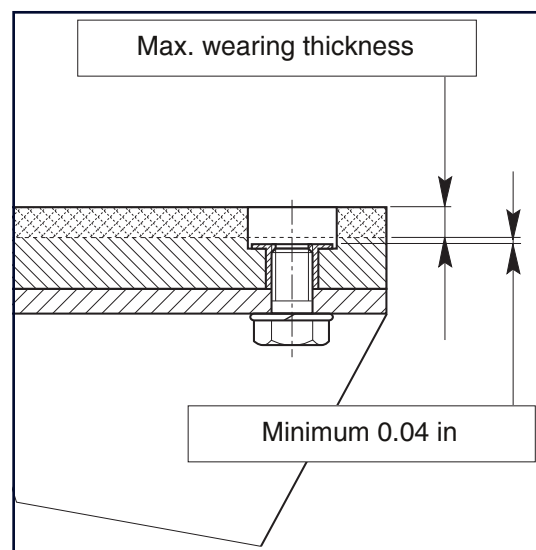
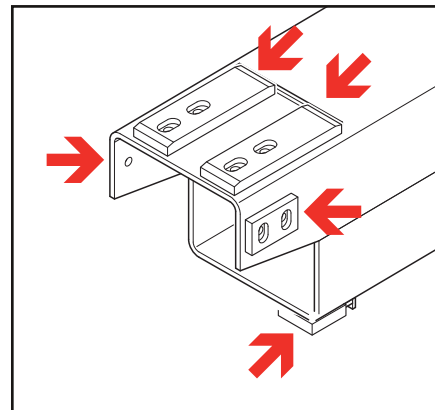
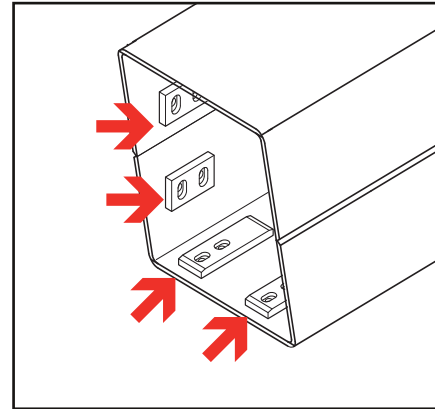

Maintenance

■ BLOCK VALVES fitted to all CYLINDERS

All machine's cylinders are equipped with block valves:

- Compensation cylinder
- Lifting cylinder
- Telescopic boom extension cylinder
- Attachment swinging cylinder

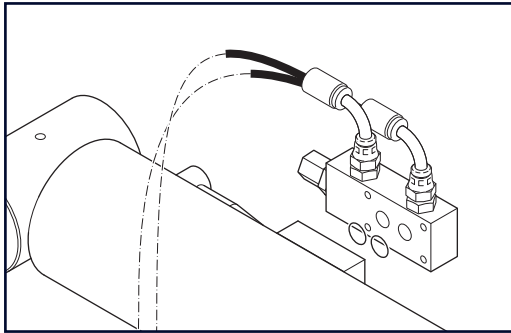

■ Checking the block valves (every 3 months)

The piloted blocking valves allow to held the load in position in case of burst of a flexible hose. To check the efficiency of a valve, proceed as follows:

- Load a weight near the maximum payload onto the boom.
- Raise the load some centimetres above the ground (max 4 in). To check the valve on the telescope extension cylinder move the boom to maximum height and extend it some centimetres.
- Loosen the oil hoses to the cylinder of which you are checking the valve with caution.
- To check the efficiency of the block valves of the outriggers, lower them to the ground and unload the weight of the tyres without raising them. Loosen the cylinder hoses to check the efficiency of the valve.

During the check, the oil will flow out of the hoses and the load shall remain blocked in position. Should that not be the case, the valve must be replaced. Contact TEREXLIFT Technical Service.

■ To remove the block valves or the cylinders

- Lower the boom to the ground in a firm way since the removal of the block valve or the cylinder can cause an uncontrolled down-movement.
- After refitting the valve or the cylinder, replenish the circuit and eliminate any air before starting working. To eliminate the air from the circuit, move the involved cylinders to end-of-stroke in the two directions (opening/closing. To eliminate the air from the fork balance cylinder, move the boom up and down and tilt the fork plate forwards/back.



Do the check of the valves taking all the possible precautionary measures:

- **Wear safety glasses**
- **Wear safety gloves**
- **Wear safety shoes**
- **Wear suitable working clothes**
- **Use guards against leaks of oil at high pressure**
- **Do the check in a free space with barriers all around to keep non-authorized people away**
- **Ensure that the part to be checked is in safe condition and that the action generated does not result in an uncontrolled movement of the machine.**

Maintenance

■ Checking the MACHINE START CONTROL (at every use)

Attempt to start the engine with the forward or reverse gear put.

The engine must not start. If the engine starts, contact the TEREXLIFT Technical Service.

Repeat the operation putting first one gear, then the other.

■ CHECKING THE STATE OF THE STRUCTURE

Five years or 6000 hours after the first placing into operation of the machine (whichever occurs first), check the state of the structure paying an extreme attention to the welded supporting joints and the pins of both boom and platform (if present).



After the first 5 years, repeat this check every 2 years.

Maintenance

ELECTRICAL SYSTEM

WARNING

All maintenance interventions must be carried out with engine stopped, parking brake engaged, working attachments on the ground and gearbox lever in neutral.

WARNING

When raising a component for maintenance purposes, secure it in a safe way before carrying out any maintenance.

WARNING

Any intervention on the electrical system unless performed by authorized personnel, is expressly forbidden.

BATTERY

- Check the electrolyte level every 250 working hours; if necessary, add distilled water.
- Ensure the fluid is about 0.2 in above the plates and the cell levels are correct.
- Check the cable clips are well secured to the battery terminals. To tighten the clips, always use a box wrench, never pliers.
- Protect the terminals smearing them with pure vaseline.
- Remove the battery and store it in a dry place, when the machine is not used for a long time.

WARNING

- **Battery electrolyte contains sulphuric acid. It can burn you if it touches your skin and eyes. Always wear goggles and protective gloves, and handle the battery with caution to prevent spillage. Keep metal objects (watch straps, rings, necklaces) clear of the battery leads, since they can short the terminals and burn you.**
- **Before disconnecting the battery, set all switches within the cab to OFF.**
- **To disconnect the battery, disconnect the negative (-) lead from the frame earth first.**
- **To connect the battery, connect the positive (+) lead first.**
- **Recharge the battery far from the machine, in a well-ventilated place.**
- **Keep out of items which can produce sparks, of naked flames or lit cigarettes.**
- **Do not rest metal objects onto the battery. This can result in a dangerous short especially during a recharge.**
- **Because the electrolyte is highly corrosive, it must never come in contact with the frame of the handler or electric/electronic parts. If the electrolyte comes in contact with these parts, contact the nearest authorised assistance centre.**

WARNING

Risk of explosion or shorts. During the recharge, an explosive mixture with release of hydrogen gas forms.

CAUTION

Do not add sulphuric acid; add only distilled water.

Maintenance

■ FUSES AND RELAYS

The electrical system is protected by fuses placed in the driving cab, on the left. Before replacing a blown fuse with a new one having the same amperage, find out and rectify the fault.

■ Cabin Fuses

REF.	DESCRIPTION	AMP.
F01	WARNING	10
F02	HIGH BEAM	15
F03	LOW BEAM	15
F04	HORN	15
F05	CONTINUOUS FLOW	10
F06	R-FRONT & L-REAR POSITION LIGHTS	5
F07	L-FRONT & R-REAR POSITION LIGHTS	5
F08	POWER SUPPLY OPT	10
F09	STEERING MODE	10
F10	LOCK/UNLOCK ATTACHMENT	5
F11	HEATING	25
F12	GEAR SELECTOR	10
F13	WORK LIGHT	15
F14	WINDSCREEN WASHER	10
F15	FLASHING BEACON	10
F16	STOP LIGHT	10
F17	ROAD LIGHTS	10
F18	EMERGENCY STOP	10
F19	WIPER	10
F20	INSTRUMENT PANEL	10

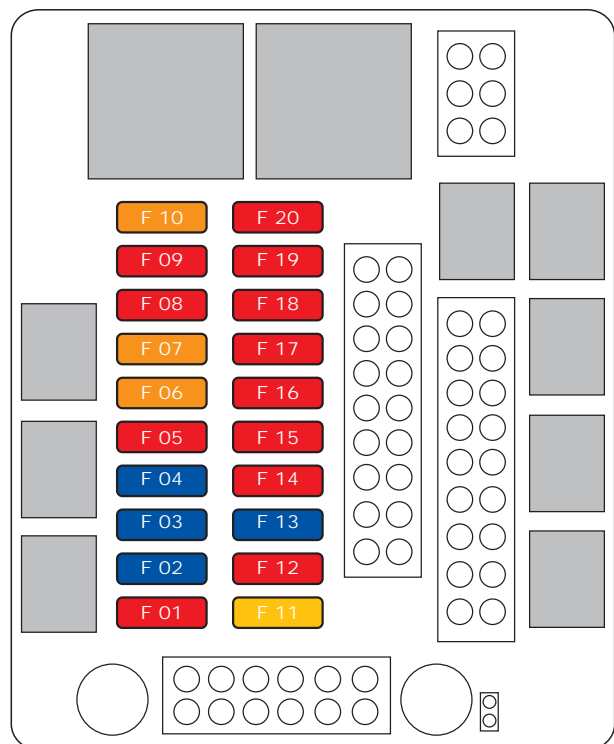

Maintenance

■ Engine compartment fuses and relays (Deutz Version)

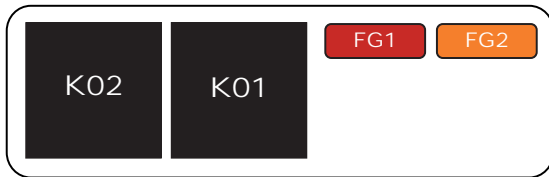

REF	DESCRIPTION	AMP
FG1	MAIN FUSE	50
FG2	GLOW PLUGS FUSE	40
K01	GLOW PLUGS PREHEATING	
K02	ENGINE STARTER	

 **CAUTION**

- Do not use fuses having a higher amperage than that recommended, since they can damage the electric system seriously.
- If the fuse blows after a short time, look for the fault source by checking the electric system.
- Always keep some spare fuses for an emergency.
- Never try to repair or short blown fuses.
- Make sure the contacts of fuses and fuse-sockets ensure a good electric connection and are not oxidised.

Maintenance

REFUELLING

Part	Product	Deutz Capacity (USgal)	Perkins Capacity (USgal)
Diesel engine	Engine oil	2.6	2
Engine cooling system	Water+antifreeze	3.4	3.4
Fuel tank	Diesel fuel	15.6	15.6
Hydraulic system tank	Hydraulic oil	17	17
Front differential gear with reduction gear	Oil	1 + 0.2	1 + 0.2
Rear differential	Oil	1	1
Front wheel reduction gears	Oil	0.4	0.4
Rear wheel reduction gears	Oil	0.4	0.4

PRODUCT SPECIFICATIONS

Engine oil

Use the oil recommended by the Diesel engine Manufacturer (see the relevant handbook delivered with the machine).

At the delivery, the machine is refilled with:

SHELL RIMULA SAE 15W-40 (API CH-4 / CG-4 / CF-4 / CF, ACEA E3, MB 228.3)

Lubrication oils and relevant filtering elements

Refill the machine with following lubricants:

Use	Product	Definition
Power divider-Differential gears- Reduction gears	TRACTORENAULT THFI 208 LF SAE 80W	API GL4 / FORD M2C 86B Massey Ferguson M1135
Hydraulic system and brakes	SHELL TELLUS T46	DENISON HF-1 DIN51524 part 2 & 3



Never mix different oils: this may result in troubles and component breaks.

Oils for hydraulic system:

Arctic climates: Temperatures below 14°F

Use SHELL Tellus T22

Mild climates: Temperatures from 5°F to 113°F

Use SHELL Tellus T46

Tropical climates: Temperatures above 86°F

Use SHELL Tellus T68

Maintenance

Fuel

Refuel through cover **A**. Use only Diesel fuel with less than 0.5% sulphur content, according to the specifications of the diesel engine operation handbook.



In cold climates (temperature under -4°F) use only "Arctic" type Diesel fuel, or oil-diesel fuel, or oil-diesel fuel mixtures. The composition of the latter can vary in relation to the ambient temperature up to max. 80% oil.

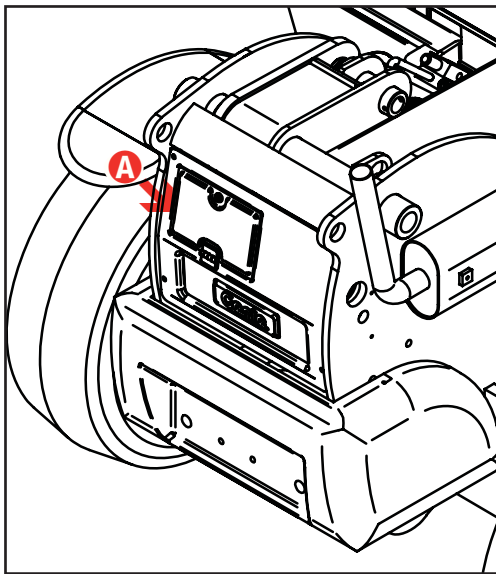

Grease

For the machine greasing, use:

Lithium-based Vanguard LIKO grease, type EP2	When greasing by pump.
Graphitized AGIP grease, type GR NG 3	When greasing by brush.
INTERFLON FIN GREASE LS 2	On the telescopic boom



Avoid mixing greases of different type or features and do not use greases of lower quality.

Engine coolant

It is advisable to use an antifreeze mixture (50% water-50% antifreeze). At the delivery, the machine is refilled with:

TEREX PRO COOL by VALVOLINE

The use of this product guarantees protection to the circuit for 3 years or 7000 hours without having to add any dry coolant additive.

TEREX PRO COOL Protection against boiling / freezing		
Product %	Freezing point	Boiling point
33	1.5°F	253°F
40	-11°F	259°F
50	-33°F	262°F
70	-88°F	275°F



Use an antifreeze mixture in the proportions recommended by the manufacturer in relation to the ambient temperature of the jobsite.

Faults And Troubleshooting

■ FAULTS AND TROUBLESHOOTING

This chapter represents a practical guide for the operator for fixing the most common failures and, at the same time, detecting those interventions that must be carried out by qualified technical engineers.

If you are unsure about anything, do not carry out operations on the machine, but call in a skilled technician.



Any repair work, maintenance or troubleshooting must be carried out with machine stopped, boom in rest position or laid on the ground, parking brake engaged and ignition key removed.

PROBLEM	CAUSES	SOLUTIONS
THE DASHBOARD DOES NOT TURN ON	<ul style="list-style-type: none"> The 50A fuse F61 supplying power to the dashboard is blown (engine compartment) Battery down 	<ul style="list-style-type: none"> Replace the fuse Check the battery
THE STARTER DOES NOT RUN	<ul style="list-style-type: none"> Forward/reverse gear selector Battery down 	<ul style="list-style-type: none"> Set the lever on neutral position Recharge or replace the battery
THE STARTER RUNS, BUT THE ENGINE DOES NOT START	<ul style="list-style-type: none"> Fuses F8 and F12 blown No fuel Diesel fuel filter clogged Diesel fuel hose empty (fuel used up) Solenoid valve - engine stop 	<ul style="list-style-type: none"> Check the fuses Refuel See engine operator manual Refuel, then refer to engine operator manual Check the solenoid valve; replace, if necessary
THE MACHINE DOES NOT MOVE FORWARD/BACK	<ul style="list-style-type: none"> Speed selector switch in neutral Parking brake engaged Fuse F12 blown 	<ul style="list-style-type: none"> Set the speed selector switch correctly Disengage Check the fuse; replace, if necessary
NO SELECTION OF THE STEERING MODE	<ul style="list-style-type: none"> Fuse F9 controlling the steering selection blown Steering mode selector 	<ul style="list-style-type: none"> Replace the fuse Check the selector; replace if necessary
THE MACHINE DRIVE IS NOT ENOUGH	<ul style="list-style-type: none"> Hydraulic oil filter clogged 	<ul style="list-style-type: none"> Replace the filter

Faults And Troubleshooting





PROBLEM	CAUSES	SOLUTIONS
THE HYDRAULIC OIL THERMOMETER DOES NOT WORK	This is normal, when the outside temperature is low and/or the machine is used for short periods, since the hydraulic oil cannot warm up over 104÷122°F	
THE PARKING BRAKE LIGHT DOES NOT LIGHT UP	<ul style="list-style-type: none"> • Fuse F12 blown 	<ul style="list-style-type: none"> • Replace fuse
BOOM DOES NOT MOVE	<ul style="list-style-type: none"> • Fuse F5 blown 	<ul style="list-style-type: none"> • Check and replace fuse, if necessary

NOTICE

In case of faults not listed in this chapter, address to the TEREXLIFT Technical Assistance, your nearest authorised workshop or dealer.

Faults And Troubleshooting

■ TORQUE WRENCH SETTINGS

METRIC FASTENER TORQUE CHART																
This chart is to be used as a guide only unless noted elsewhere in this manual																
Size (mm)	Class 4.6 				Class 8.8 				Class 10.9 				Class 12.9 			
	LUBED		DRY		LUBED		DRY		LUBED		DRY		LUBED		DRY	
	in-lbs	Nm	in-lbs	Nm	in-lbs	Nm	in-lbs	Nm	in-lbs	Nm	in-lbs	Nm	in-lbs	Nm	in-lbs	Nm
5	16	1.8	21	2.4	41	4.63	54	6.18	58	6.63	78	8.84	68	7.75	91	10.3
6	19	3.05	36	4.07	69	7.87	93	10.5	100	11.3	132	15	116	13.2	155	17.6
7	45	5.12	60	6.83	116	13.2	155	17.6	167	18.9	223	25.2	1.95	22.1	260	29.4
	LUBED		DRY		LUBED		DRY		LUBED		DRY		LUBED		DRY	
	ft-lbs	Nm	ft-lbs	Nm	ft-lbs	Nm	ft-lbs	Nm	ft-lbs	Nm	ft-lbs	Nm	ft-lbs	Nm	ft-lbs	Nm
8	5.4	7.41	7.2	9.88	14	19.1	18.8	25.5	20.1	27.3	26.9	36.5	23.6	32	31.4	42.6
10	10.8	14.7	14.4	19.6	27.9	37.8	37.2	50.5	39.9	54.1	53.2	72.2	46.7	63.3	62.3	84.4
12	18.9	25.6	25.1	34.1	48.6	66	64.9	88	69.7	94.5	92.2	125	81	110	108	147
14	30.1	40.8	40	54.3	77.4	105	103	140	110	150	147	200	129	175	172	234
16	46.9	63.6	62.5	84.8	125	170	166	226	173	235	230	313	202	274	269	365
18	64.5	87.5	86.2	117	171	233	229	311	238	323	317	430	278	377	371	503
20	91	124	121	165	243	330	325	441	337	458	450	610	394	535	525	713
22	124	169	166	225	331	450	442	600	458	622	612	830	536	727	715	970
24	157	214	210	285	420	570	562	762	583	791	778	1055	682	925	909	1233

NOTICE

Sensor maximum driving torque: 11 lbs/ft.

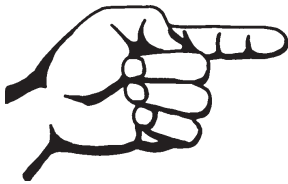

Intentionally blank page

Optional Attachments

INTRODUCTION

This section provides information on the optional interchangeable attachments, especially manufactured for the handlers.

Use only genuine attachments, described in this section, after having read their features thoroughly and understood their use.

To install and remove the attachments, follow the instructions supplied in the “**Operating Instructions**” section.



When replacing interchangeable attachments, keep any person clear of the working area.



Mounting optional attachments, and especially the extension jib, can change the centre of gravity of the machine. Before handling a load, check its weight and compare it with the values on the load charts. The weight of the used attachment must always be deducted from the rated payload.

Optional Attachments

■ SIDE TILT FORK CARRIAGE

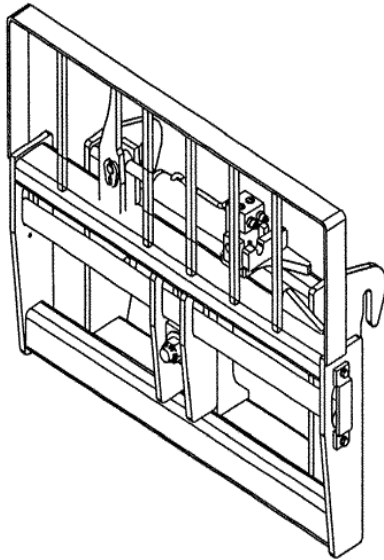

Strictly obey the general safety precautions given in section “**Safety**”.

When using the tilt feature keep the load as level as possible, using extreme caution when driving off of a slope to reposition the forks, to prevent the load from sliding off of the forks or pallet.

NOTE: If the carriage tilts or drifts due to oil leakage within the cylinder assembly, discontinue use until the problem has been corrected.

When using the shift feature to pick up a load, be sure to return the forks and load to the center position as soon as possible. Do NOT travel with loaded forks shifted to the side.

TECHNICAL DATA	
Capacity	6000 lbs
Width (without forks)	15.98 in
Length	51.48 in
Height (with protection)	41.25 in
Weight	638 lbs
Tilt Rotation	10° left and right

Application

Quick-coupling fitted attachment for handling palletised loads with possibility of rotation tilting by $\pm 10^\circ$.

Operating The Telehandler

Avoid steep hillside operation, which could cause the telehandler to overturn.

Consult the other sections of this machine operator's for maximum incline allowable.

When operating on a slope, keep the load low, and proceed with extreme caution.

Do not drive ACROSS a steep slope - drive straight up and down.

With LOADED forks - drive with the forks and load facing uphill.

With EMPTY forks - drive with the forks facing downhill.

Working With The Attachment

- Never use the attachment for a work platform or personnel carrier.
- Specified lift capacities must not be exceeded, otherwise machine stability will not be sufficient. Always observe lift capacity limits listed in machine specifications or on load charts furnished with the telehandler.
- Always check locking pins before operating any attachment.
- Never lift, move, or swing loaded forks over anyone.

Optional Attachments

- Always space the forks correctly for the load. Loads can fall off incorrectly spaced forks. Make sure the forks are completely under the load before lifting.
- Never stack loads on uneven ground. Loads stacked on uneven ground can topple.
- Never lift a load with one fork. A load lifted with one fork can slip off and cause injury.
- Secure loads properly. Unsecured loads can fall unexpectedly.
- Do not handle round bales with fork lift tines.
- Don't obstruct your vision when traveling or working. Carry the forks low for maximum stability and visibility.

Maintenance & Service

DAILY

- Check all bolts and nuts for tightness.
- Replace any missing bolts or nuts with approved replacement parts.
- Check hydraulic system for hydraulic oil leaks.
- Visually inspect the machine for worn parts or cracked welds, and repair as necessary.

EVERY 40 HOURS

Lubrication is an important part of maintenance. It is recommended that all grease fittings be lubricated after the initial 8 hours of operation, and then after every 40 hours of use.

Optional Attachments

■ SCRAP GRAPPLE

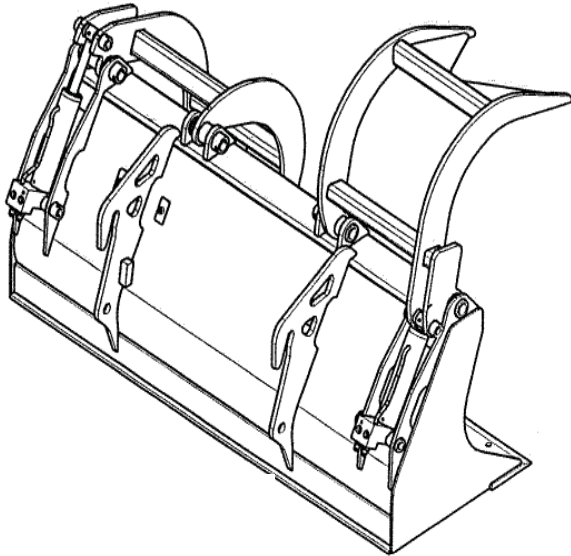

Strictly obey the general safety precautions given in section “**Safety**”.

- Never heap load heavy material where the combined weight of the bucket and the material could exceed the rated capacity of the loader.
- When using the grapple bucket, be sure that the load does not stick out too far in front of the bucket and be sure that the weight of the load is not too heavy. A light load sticking out too far can have the same tipping effect of the loader as a heavy load carried in close.
- Never operate the grapple forks when people are nearby and could be injured by the hydraulic action of the grapple.
- Do NOT obstruct your vision when traveling or working. Carry the bucket LOW for maximum stability and visibility while traveling.
- Operate at speeds slow enough so that you have complete control at all times. Travel slowly over rough or slippery ground and on hillsides.
- Stay in gear when traveling downhill. Do not shift into neutral. Maintain engine RPM to provide steering and braking functions. Use the same gear range for traveling down a grade as you would for traveling up the grade.
- Avoid steep slopes or unstable surfaces. If you must drive on a slope, keep the load low and proceed with extreme caution. Do not drive ACROSS a steep slope under any circumstances. Drive straight up and down the slope.
- Avoid turning on an incline, if at all possible. If it is necessary, use extreme caution and make the turn wide and SLOW with the bucket carried low.

TECHNICAL DATA	
Heaped Capacity	0.83 yd ³
Overall Grappl Width	78.00 in
Overall Grapple Depth	28.00 in
Grapple Height (Closed)	51.00 in
Grapple Hook Opening	42.80 in
Weight	1096 lbs

Optional Attachments

Installation

1. Install hydraulic hoses and couplers onto the 90° elbows on the valve (If not already installed).
2. See paragraph "CHANGING THE ATTACHMENT" in the "**Operating Instructions**" section for fitting the bucket.
3. Connect the bucket hydraulic couplers to the machine auxiliary hydraulics. Route hoses in such a fashion as to prevent chafing and pinching.
4. Start engine and slowly cycle grapple cylinders several times to purge system of air and check for proper hydraulic connection, hose routing and hose length.
5. Inspect for proper assembly and check for leaks by operating the telehandler and opening and closing the grapple forks.

Detaching Bucket From Telehandler

1. On firm level ground, close grapple.
2. Lower boom arms completely down on loader frame until level bucket is about two inches off the ground.
3. Turn off engine. Move control lever back and forth several times to relieve pressure in line, then disconnect quick couplers between bucket and machine auxiliary hydraulic oil lines.
NOTE: Connect hydraulic couplers together to prevent contaminants from entering the bucket hydraulic system.
4. See paragraph "CHANGING THE ATTACHMENT" in the "**Operating Instructions**" section for detaching (removing) an attachment.
NOTE: Frequent lubrication of grease fittings on the end of all pivot pins (with a multi-purpose grease) will greatly increase life of product.

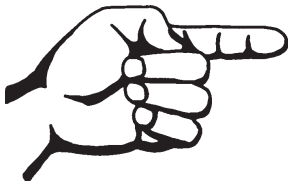

Intentionally blank page

Specifications

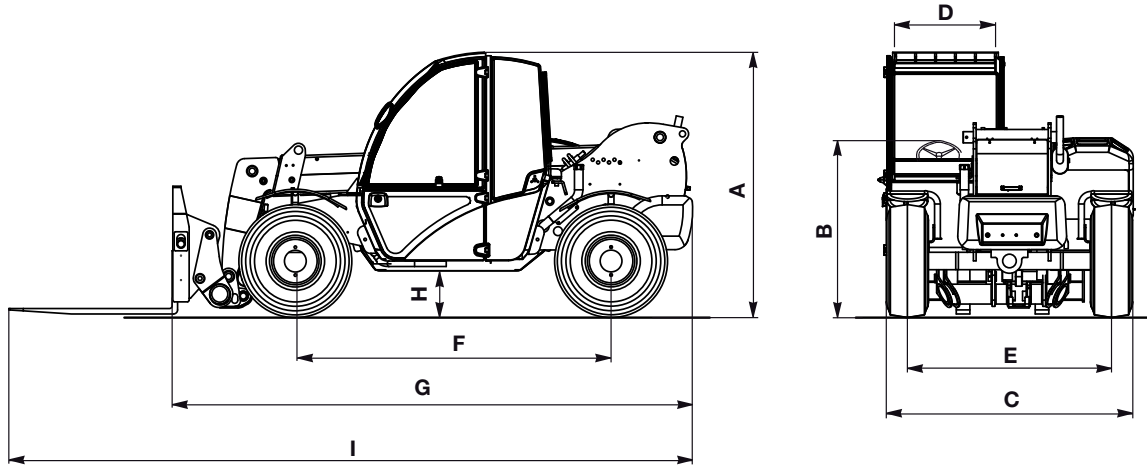

MEASUREMENTS	
A	Height 6ft 4in
B	Height at steering wheel 4ft 1in
C	Width 5ft 11in
D	Inside cab width 2ft 6in
E	Track 4ft 11in
F	Wheelbase 7ft 7in
G	Length at fork-holder plate 12ft 7in
H	Ground clearance 1ft 1in
I	Overall Length 16ft 7in
	Lifting height (max) 19ft
	Lifting capacity(max) 5500lbs
	Lift capacity at maximum height 4400lbs
	Lift capacity at maximum reach 1900lbs
	Forward reach (max) 11ft
	Reach at maximum height 2ft
	Fork-holder plate rotation 130°
	Weight*** 9810lbs
PRODUCTIVITY	
	Lifting/lowering speed** 7s/4s
	Extension/retraction speed** 7s/4s
	Inside/outside turning radius 5ft 9in/9ft 10in
	Break-out force (with 500lb shovel SAE J732/80) 8157 lbs
	Towing capacity at dynamometer*/** 9325lbs/6835lbs
	Travel speed (max) 15 mph
	Chassis levelling on both axles 2.3°
	Floating forks L 3ft 11in section 3,9in x 1,6in
	Tyres(DIN 70631) 12-16.5, 8 holes wheel disk

Specifications

■ POWER		
Engine	Deutz	Perkins
Model	D2011 L04	804D.33
Displacement	220 in ³	210 in
Cylinder arrangement	Vertical in line	Vertical in line
Combustion System	In-direct injection	In-direct injection
Max Power Output	68 hp (@2600 rpm)	63 hp (@2500 rpm)
Max Torque Output	155 lb-ft (@1700 rpm)	147 lb-ft (@1600 rpm)
Rated Power	136 ft-lb/68hp (@2600rpm)	132 ft-lb/63hp (@2500rpm)
Aspiration	Naturally aspirated	Naturally aspirated
Cylinder's number	4	4
Alternator rating	95 A	95 A
Battery CCA rating	720 A	720 A
Hydraulic		
Hydraulic output/pressure	18.5 USgal/min / 4061 psi	17.8 USgal/min / 4061 psi
■ FLOOR LOADING SPECIFICATIONS		
Occupied Floor Area		45,21 ft ²
Occupied Floor Pressure		20,2 psi
Max. Tire Load		8918 lbs
Max Axle Load		17835 lbs
Tire Contact Pressure		44,96 psi

*Max Load; ** No Load; ***With Fork

Specifications

■ CENTER OF GRAVITY GTH-5519

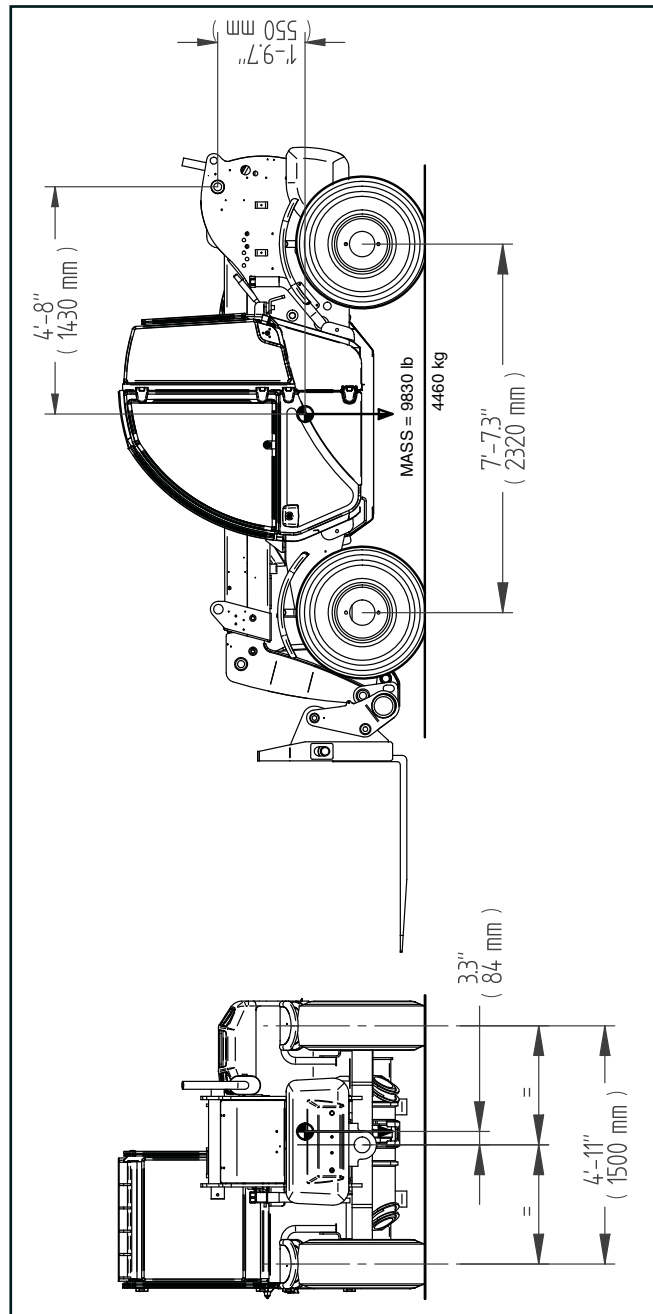

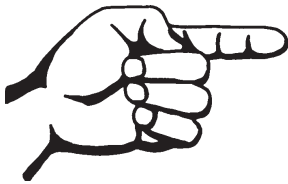

Intentionally blank page

Load Charts

■ GTH 5519 UNIVERSAL ATTACHMENT ADAPTER

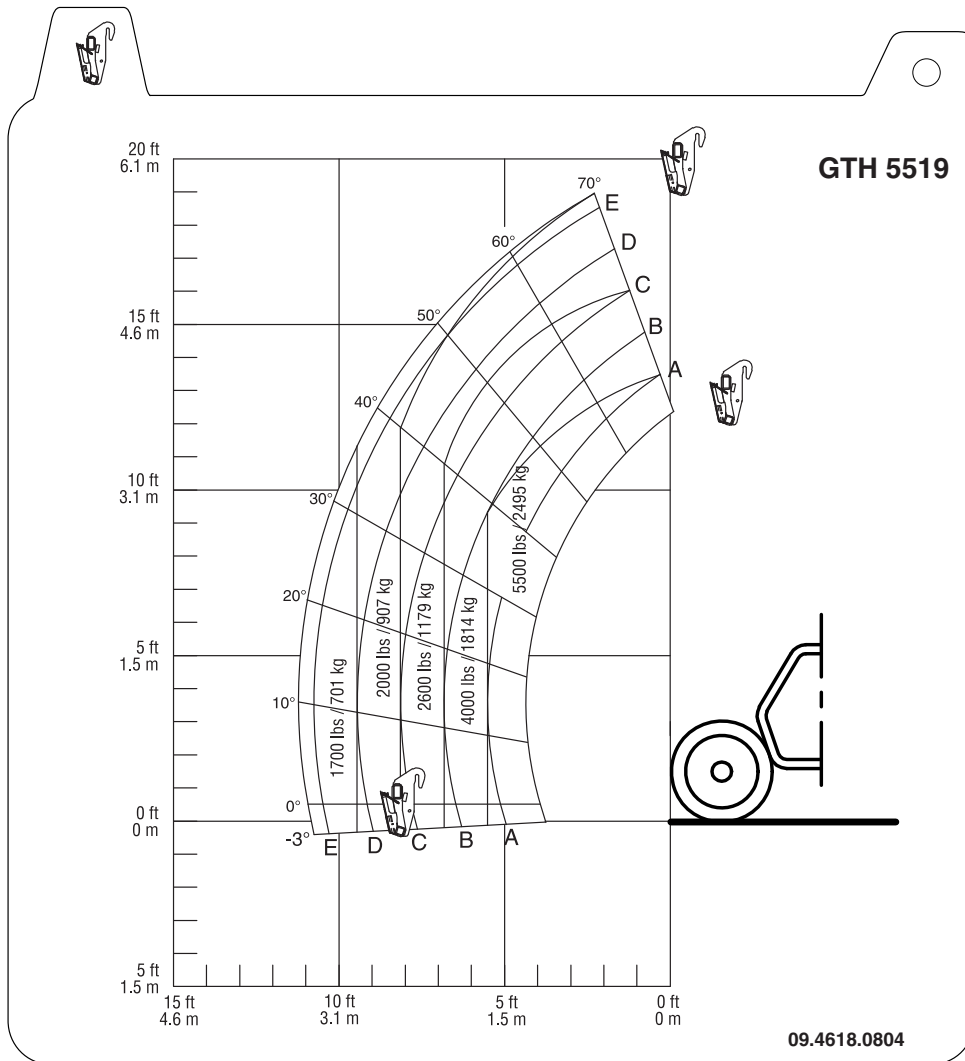

Load Charts

■ GTH 5519 FLOATING FORKS

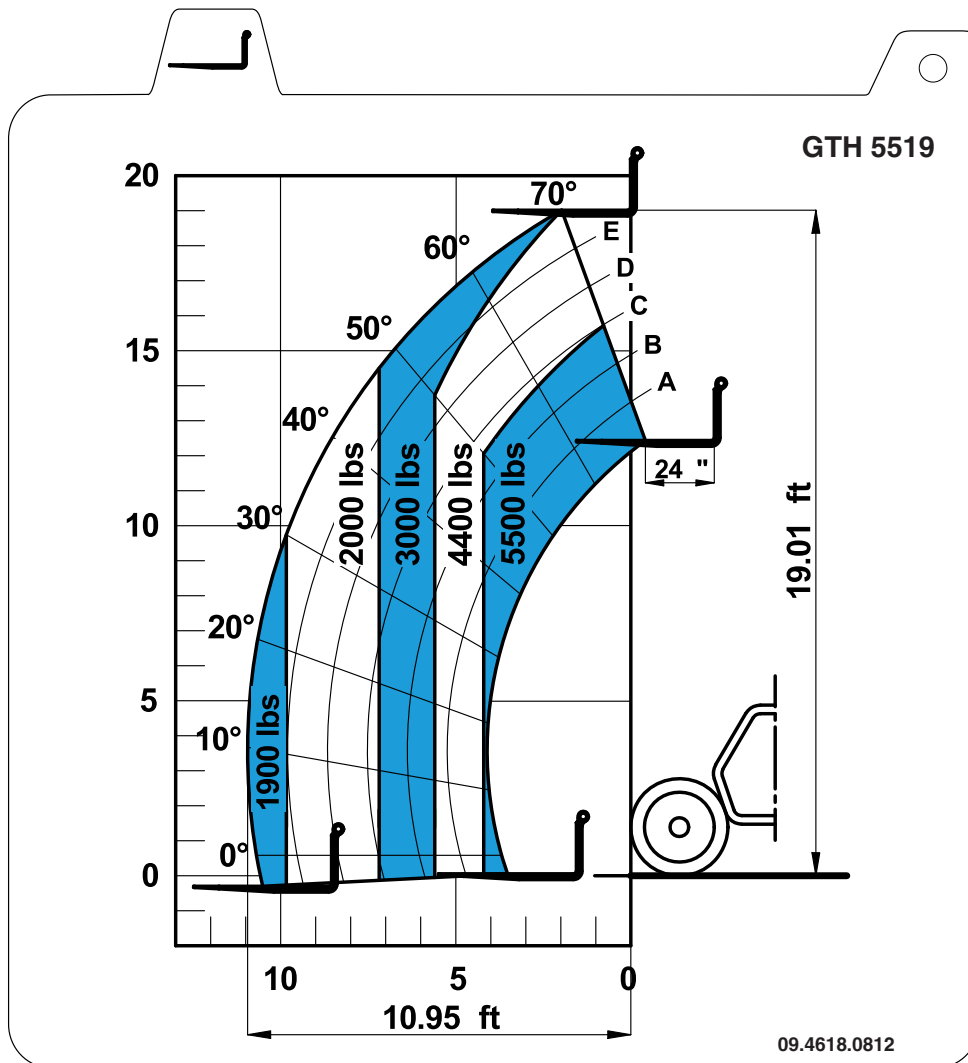

Load Charts

■ GTH 5519 SCRAP GRAPPLE BUCKET

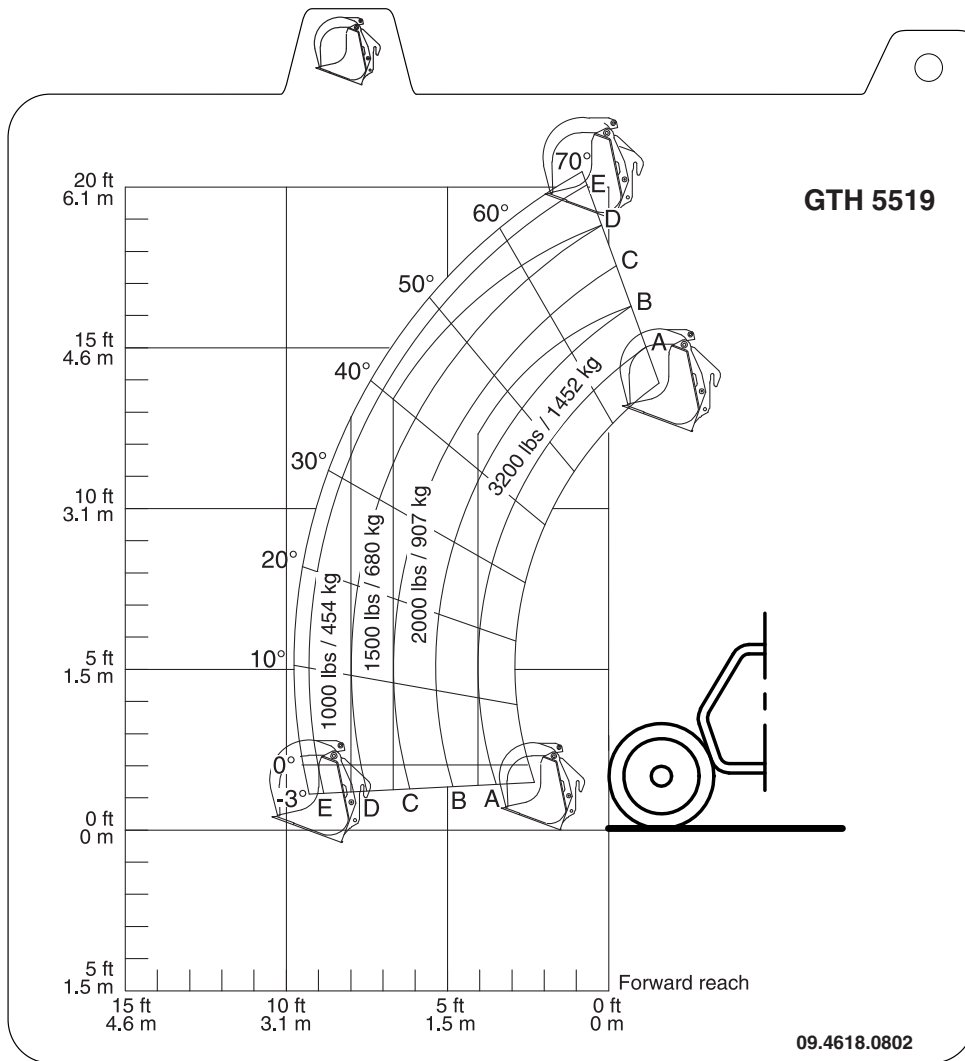

Load Charts

■ GTH 5519 TRUSS BOOM

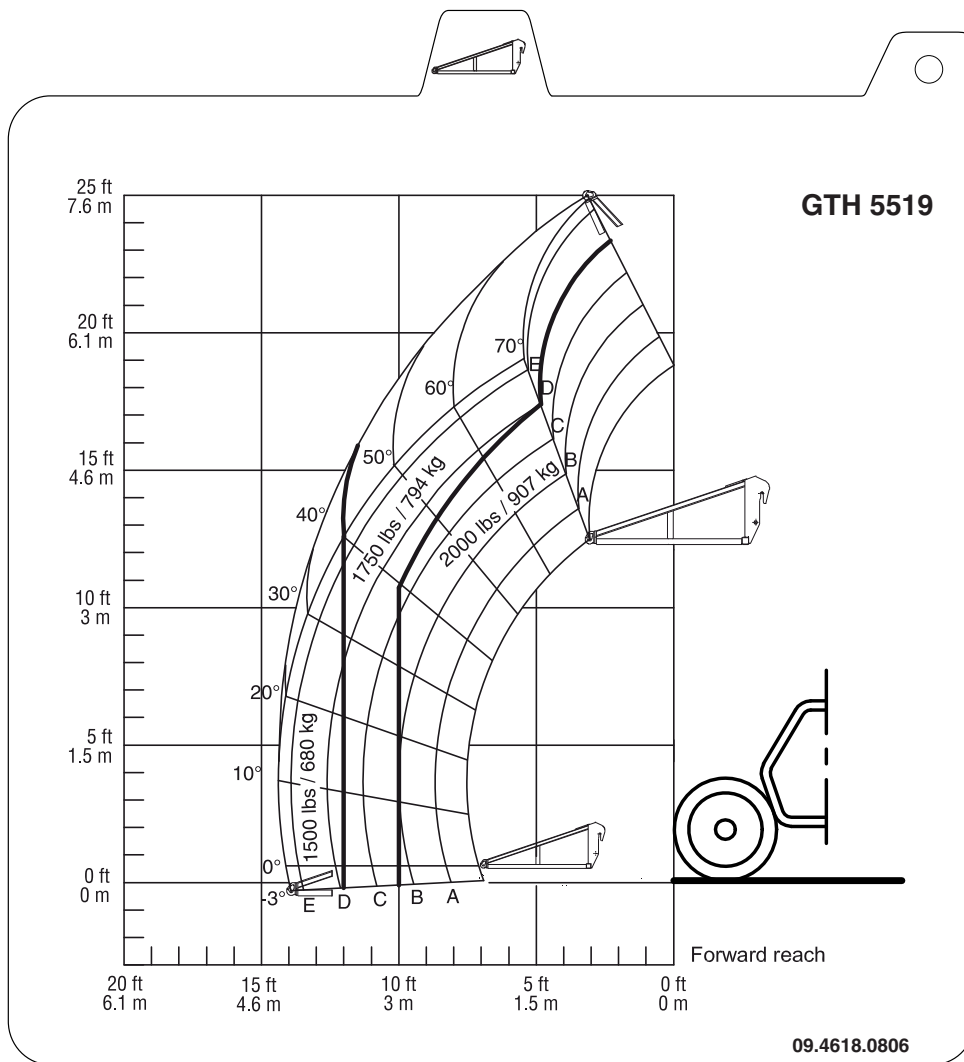

Load Charts

■ GTH 5519 60 INCH FORKS - OPTIONAL 48 INCH FORKS - 48 INCH CUBING TINES

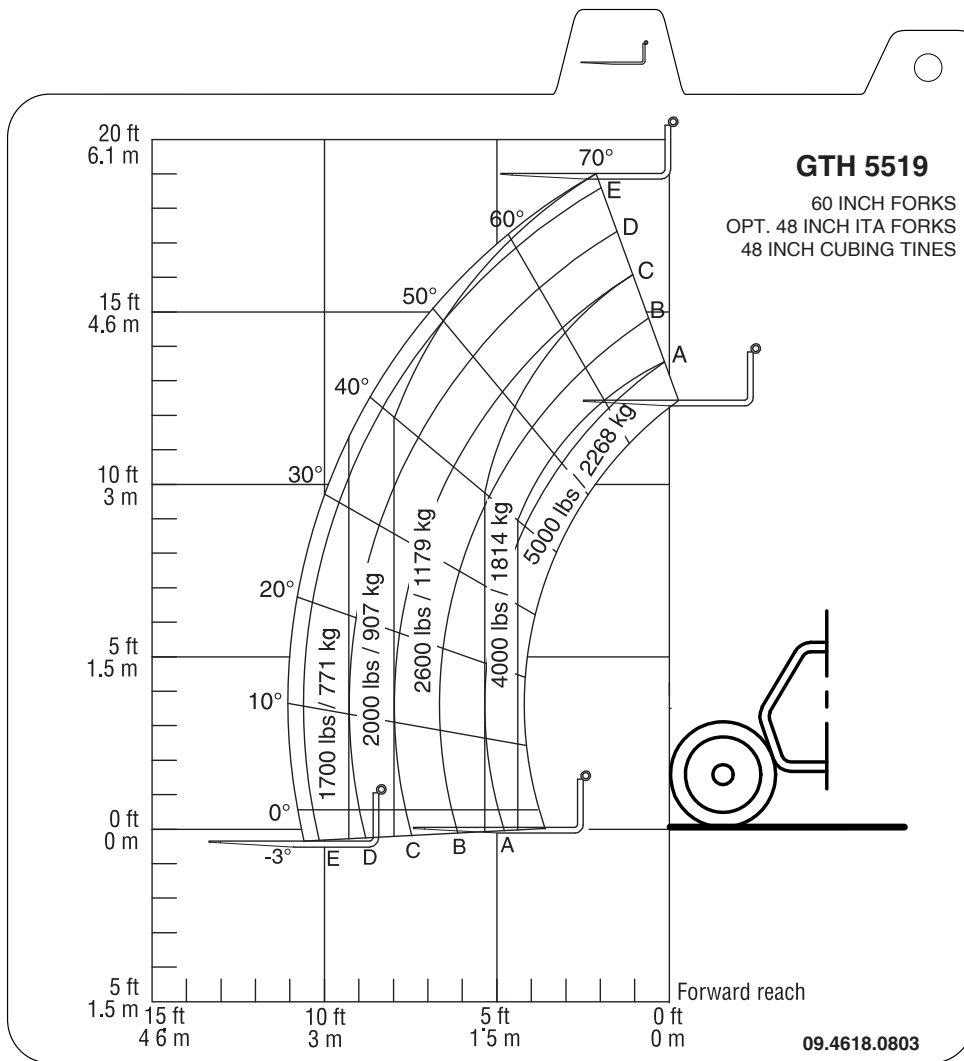

Load Charts

■ GTH 5519 60 INCH OR 66 INCH BUCKET

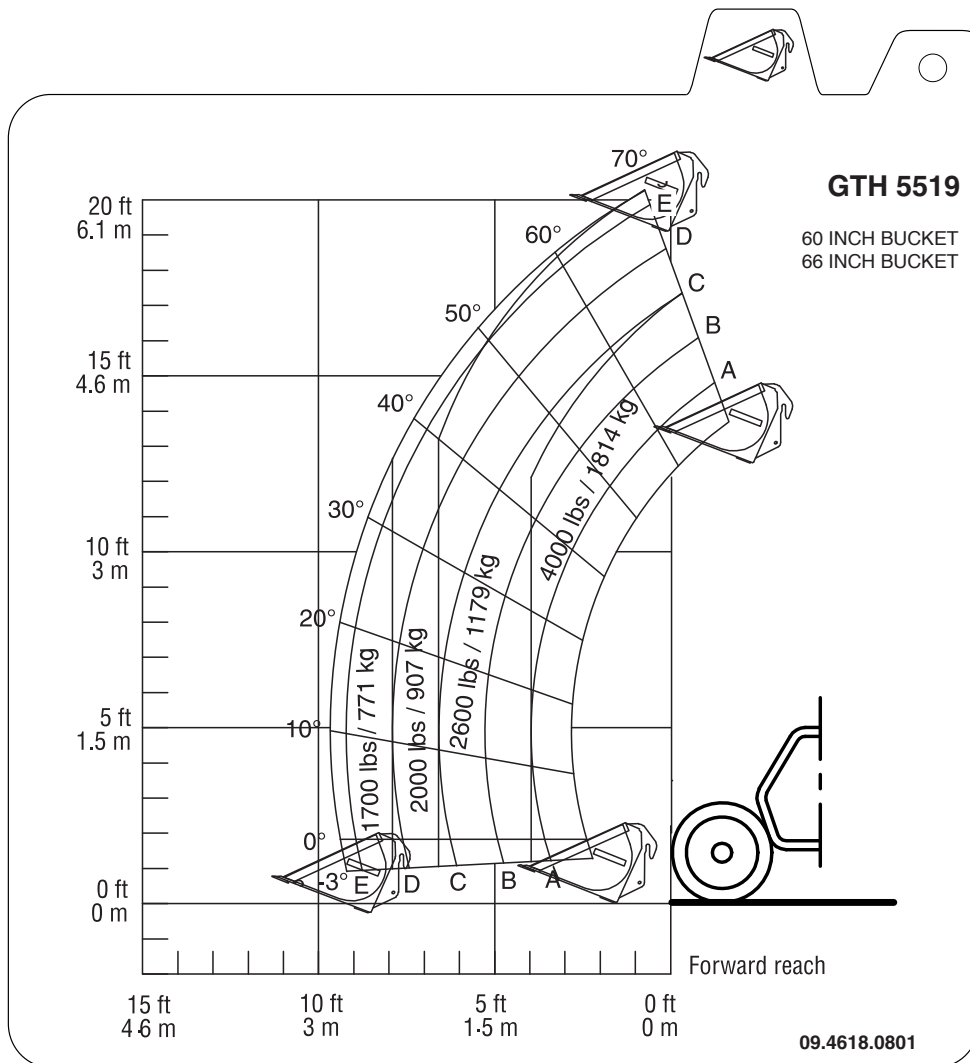

Load Charts

■ GTH 5519 ROTATING OR SIDE SHIFT FORK CARRIAGE - STANDARD FORK TINES

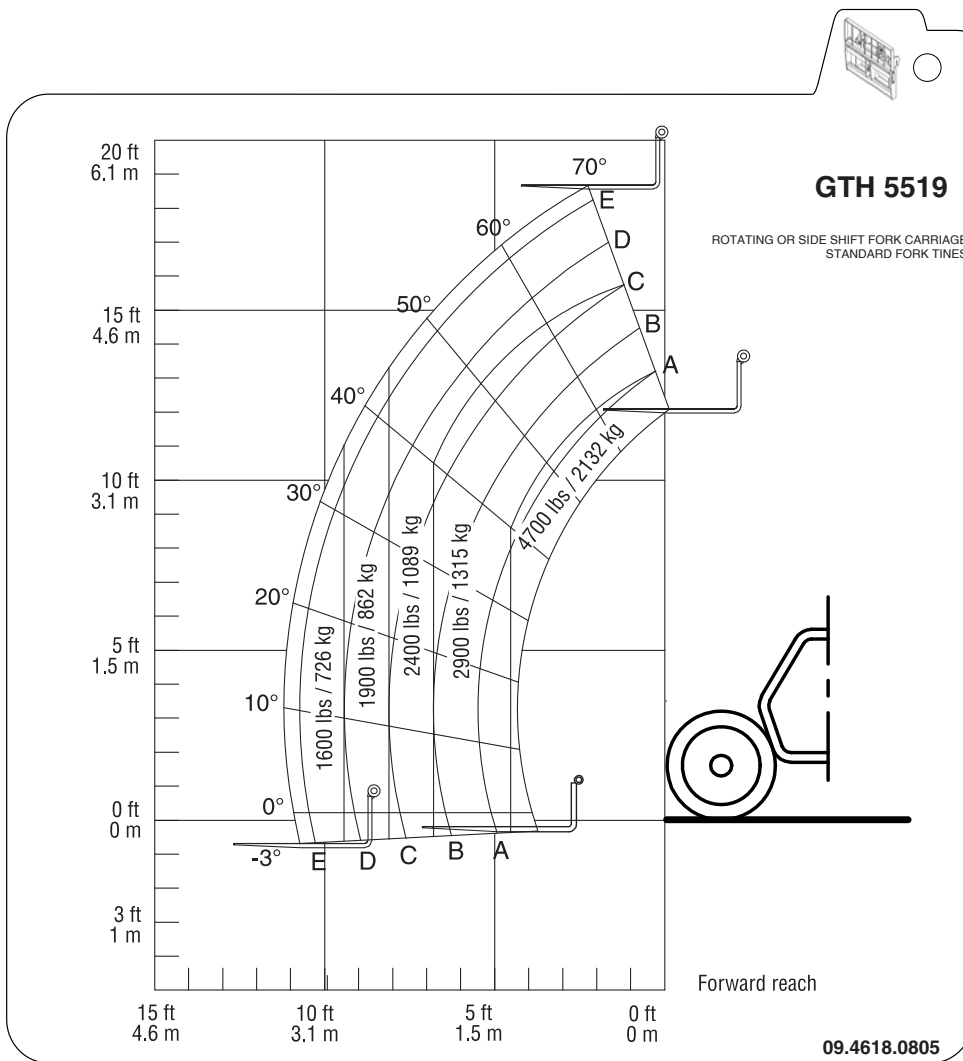

Load Charts

■ GTH 5519 SIDE SHIFT FORK CARRIAGE - 60" FORK TINES

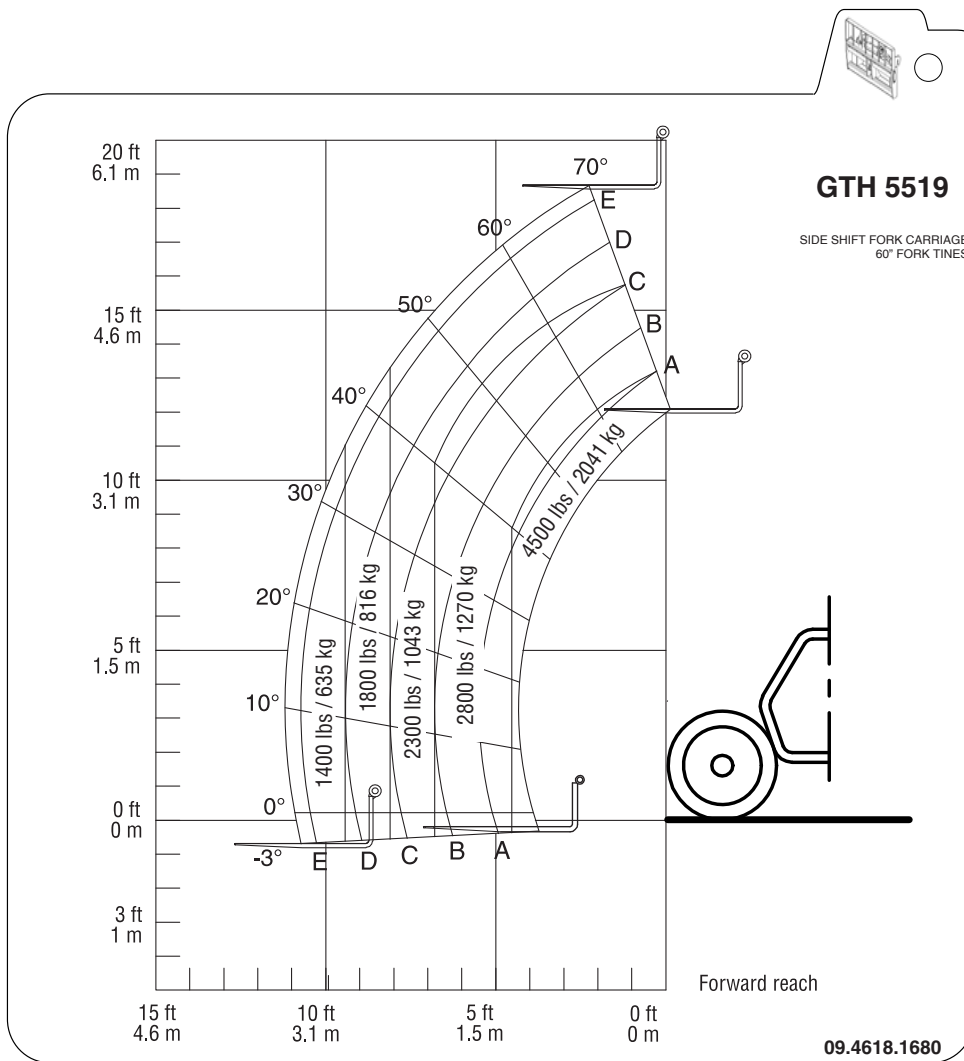

Diagrams And Schemes

■ GTH 5519 WIRING DIAGRAM 1/5 (Rev.G, P/N: 57.1800.5109)

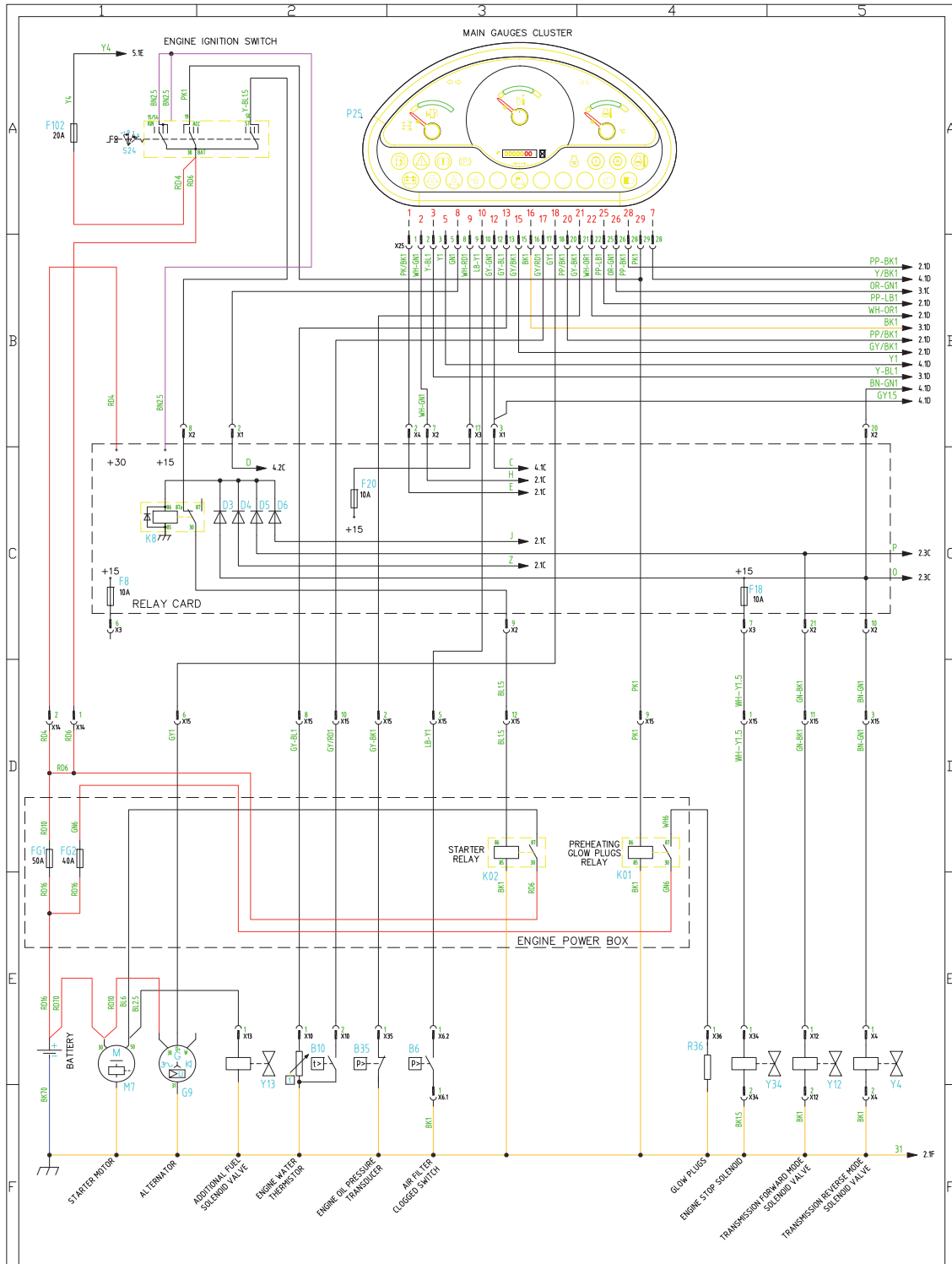

Diagrams And Schemes

■ GTH 5519 WIRING DIAGRAM 2/5 (Rev.G, P/N: 57.1800.5109)

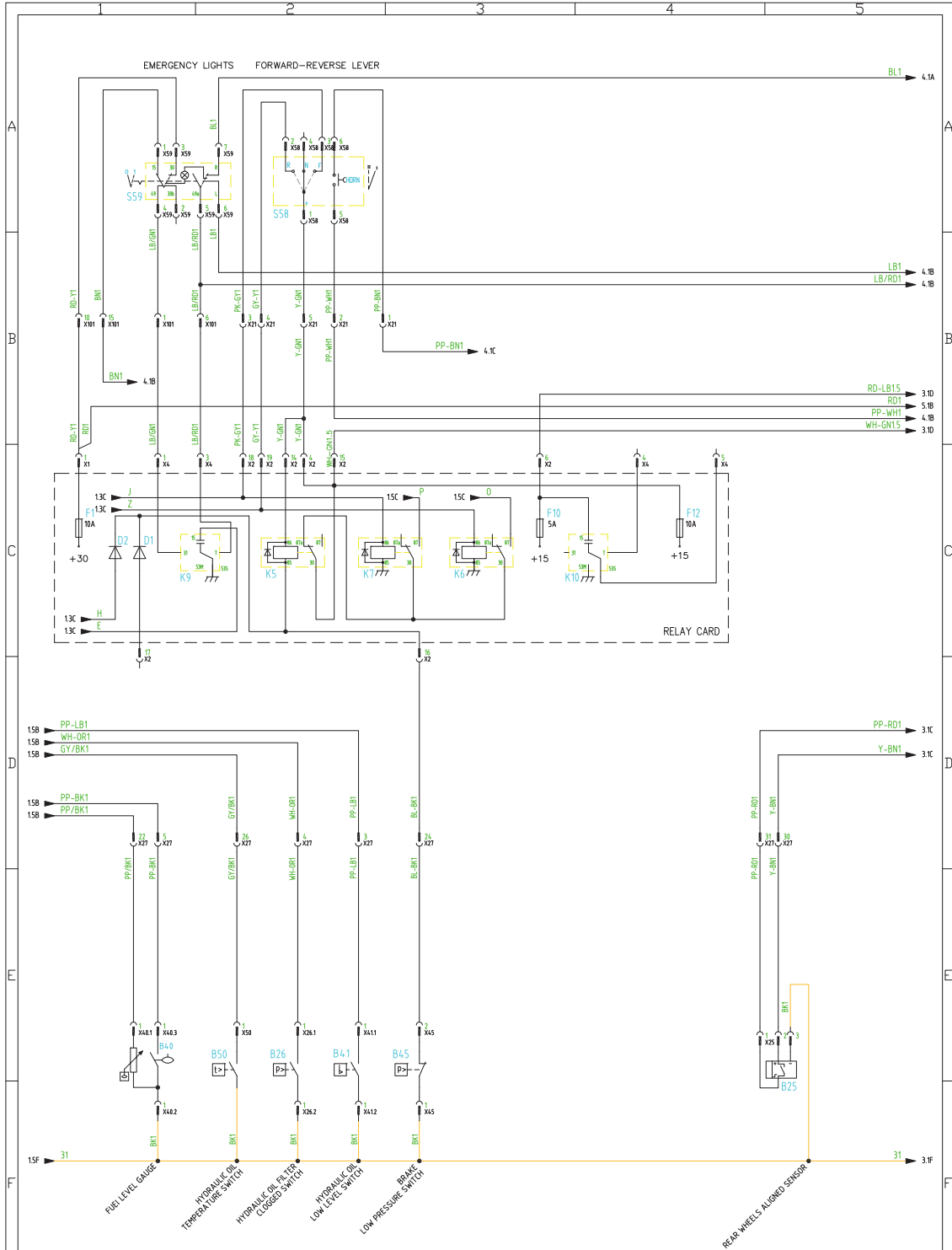

Diagrams And Schemes

■ GTH 5519 WIRING DIAGRAM 3/5 (Rev.G, P/N: 57.1800.5109)

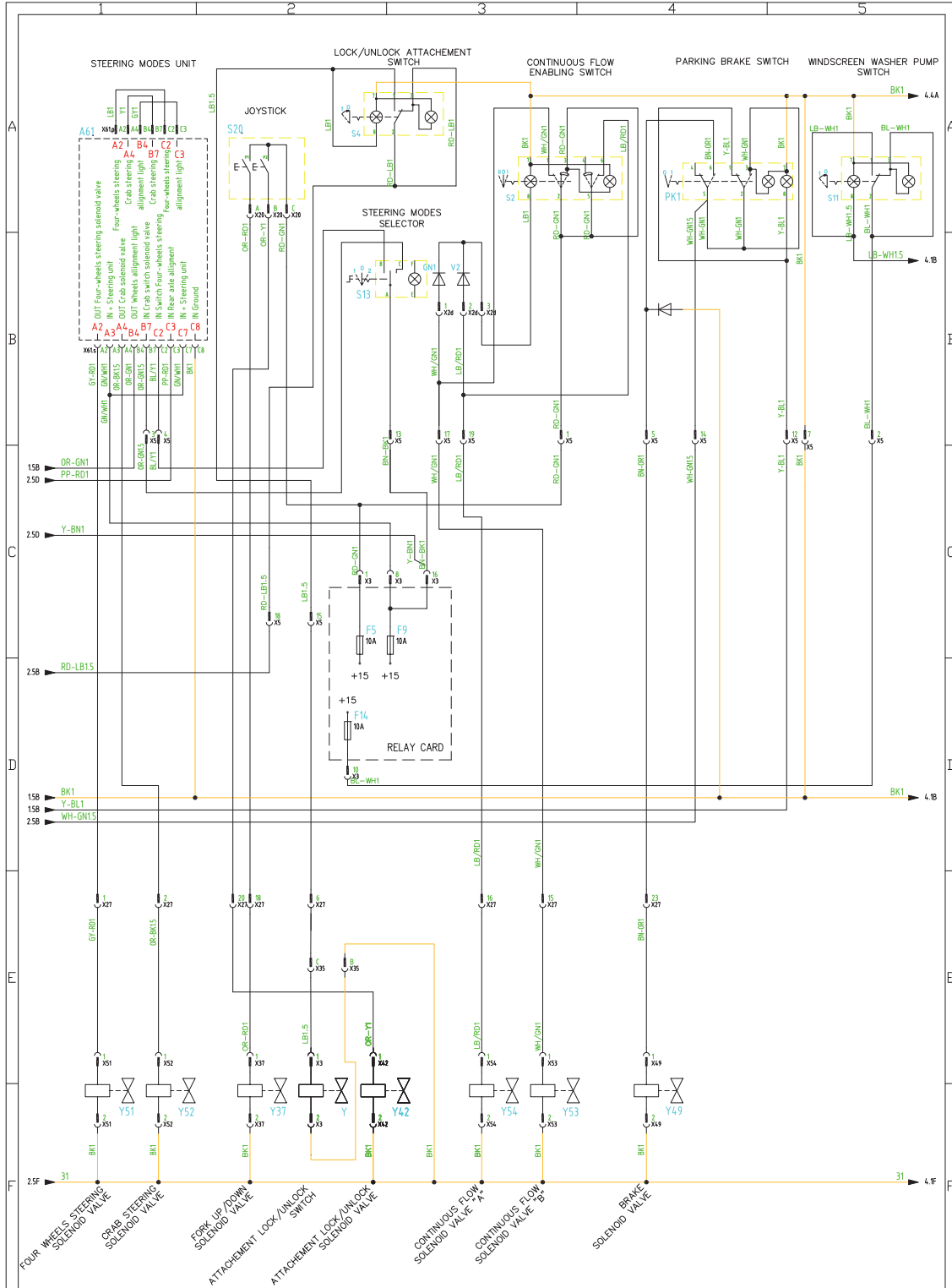

Diagrams And Schemes

■ GTH 5519 WIRING DIAGRAM 4/5 (Rev.G, P/N: 57.1800.5109)

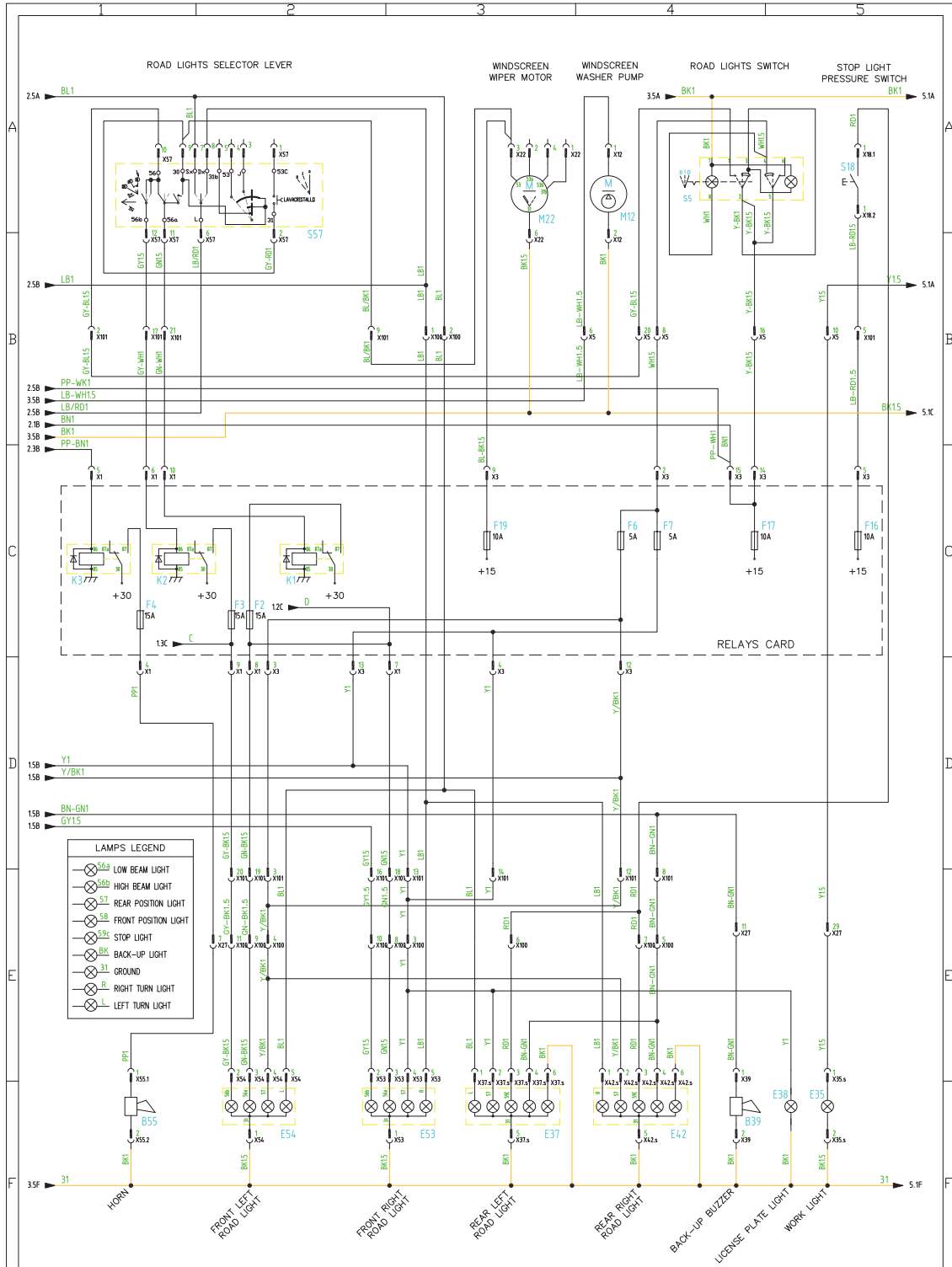

Diagrams And Schemes

■ GTH 5519 WIRING DIAGRAM 5/5 (Rev.G, P/N: 57.1800.5109)

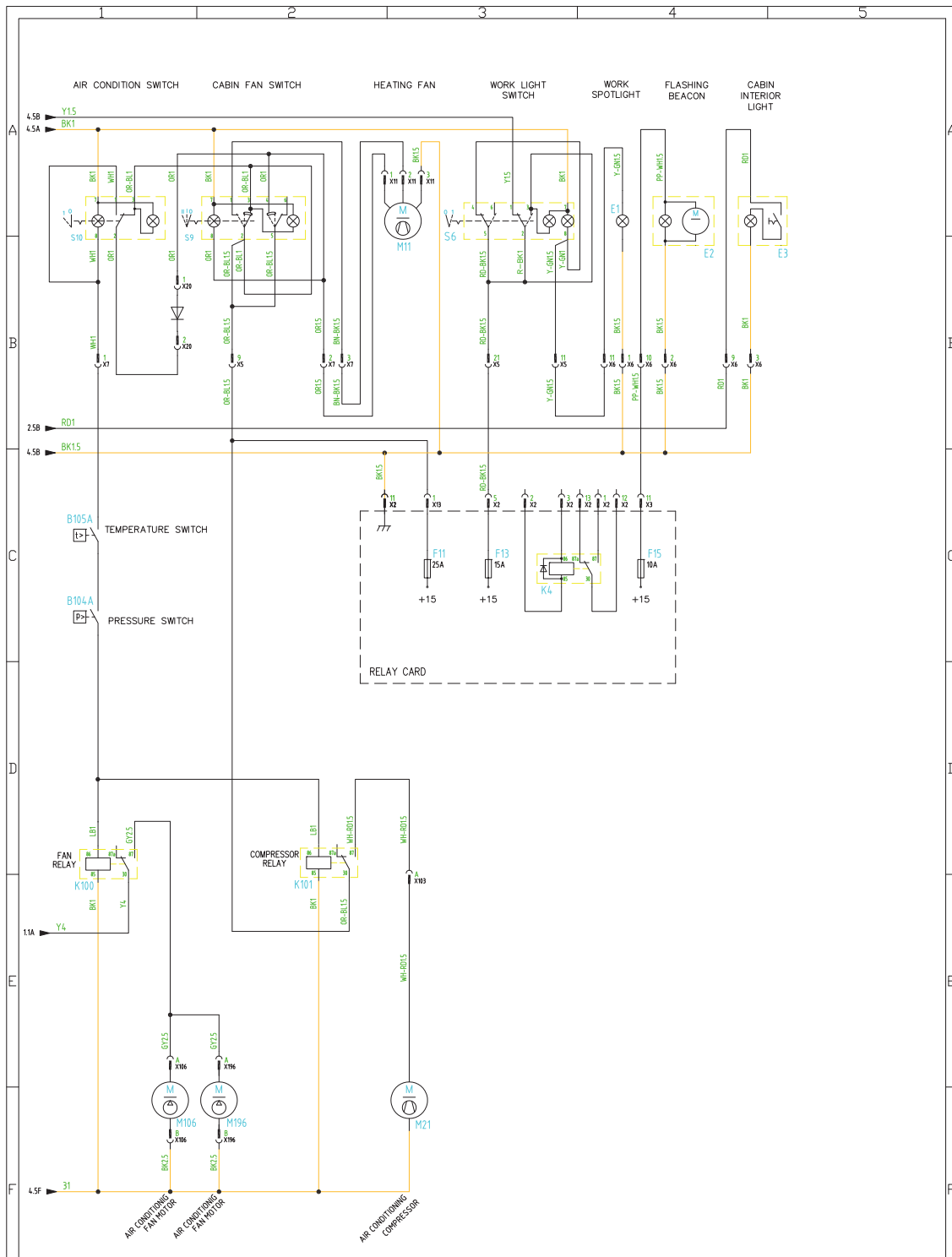

Diagrams And Schemes

■ GTH 5519 HYDRAULIC DIAGRAM (Rev.C, P/N: 57.2201.3000)

