

VERTICAL STACKED WATER SOURCE HEAT PUMPS

HIGH EFFICIENCY VSCS SERIES • 13 EER



Nomenclature

VERTICAL STACKED WATER SOURCE HEAT PUMP - CABINET

VSB 12 M 1 D A A 2 2T 4 0 A

PRODUCT CATEGORY

- VSB = Vertical Stacked Heat Pump - Standard Cabinet Assembly
- VSM = Vertical Stacked Heat Pump - Master Cabinet Assembly
- VSS = Vertical Stacked Heat Pump - Slave Cabinet Assembly
- VST = Vertical Stacked Heat Pump - Standard Cab Single Riser Assembly

UNIT CAPACITY

- 09 = .75 TON 24 = 2 TON
- 12 = 1 TON 30 = 2.5 TON
- 15 = 1.25 TON 36 = 3 TON
- 18 = 1.5 TON

CONTROL OPTIONS

	Thermostat Location			
	Remote	Whip	Surface	ADA Door
2-Speed Unit-Mounted Switch	M	W	P	A
3-Speed Thermostat Control	3	4	5	7

VOLTAGE

- 1 = 208/230-60-1
- 6 = 265-60-1

ELECTRICAL CONNECTION

- O = None (Terminal Block)
- D = Non-Fused Disconnect
- F = Disconnect w/Fuses

BLOWER OPTIONS

- A = PSC Blower
- B = Hi-Static PSC
- E = ECM Blower
- F = Hi-Static ECM
- G = ECM w/ Continuous Low Speed
- H = Hi-Static ECM w/ Continuous Low Speed

DESIGN SERIES

A = Current

MISC. OPTIONS

OPTION	FILTERS: MERV (DEPTH)		
	4 (1")	8 (1")	13 (2")
Galv Drain Pan	0	F	G
SST Drain Pan	S	T	U
Sealed Openings	L	M	N
SST DP w/ Sealed	C	D	E

HORIZONTAL DISCHARGE OPENING ORIENTATION

00, 0T	1H, 1T	2H, 2T	3H, 3T
X = None	B = Back F = Front L = Left R = Right	1 = Left + Front 2 = Left + Back 3 = Left + Right 4 = Right + Back 5 = Right + Front 6 = Back + Front	7 = Front + Left + Right 8 = Front + Right + Back 9 = Front + Left + Back

SUPPLY AIR CONFIGURATION

- 1H = Single Horizontal Supply
- 2H = Double Horizontal Supply
- 3H = Triple Horizontal Supply
- 0T = Top Only
- 1T = Single Horizontal Supply + Top
- 2T = Double Horizontal Supply + Top
- 3T = Triple Horizontal Supply + Top
- 00 = Field Cut (No Openings)

RISER ARRANGEMENT

- 1 = Right Hand Risers
- 2 = Left Hand Risers
- 3 = Back Risers
- 4 = R/Hand Risers With Cover
- 5 = L/Hand Risers With Cover
- 6 = Back Risers With Cover

CABINET OPTIONS

CABINET HEIGHT	NO OA OPTIONS	LEFT TOP OA ENTRY - 4" ROUND	LEFT TOP OA ENTRY - 4" ROUND W/ MOTORIZED DAMPER	RIGHT TOP OA ENTRY - 4" ROUND	RIGHT TOP OA ENTRY - 4" ROUND W/ MOTORIZED DAMPER
88" Cabinet	A	G	L	R	W
80" Cabinet	B	H	M	T	X
80" Cabinet w/ 2" Stand	C	J	N	U	Y
80" Cabinet w/ 2" Stand	E	1	3	5	7
80" Cabinet w/ 4" Stand	D	K	P	V	Z
80" Cabinet w/ 8" Stand	F	2	4	6	8

VERTICAL STACKED WATER SOURCE HEAT PUMP - CHASSIS

VSCS 12 C 1 0 0 A C 0

PRODUCT CATEGORY

VSCS = Vertical Stacked HP Chassis R-410

UNIT CAPACITY

09 = .75 TON 24 = 2 TON
 12 = 1 TON 30 = 2.5 TON
 15 = 1.25 TON 36 = 3 TON
 18 = 1.5 TON

DESIGN SERIES

C = Current

VOLTAGE

1 = 208/230-60-1
 6 = 265-60-1

WATER VALVE OPTIONS

VALVE OPTIONS	VALVE ONLY	Y-STRAINER	PUMP*	Y-STRAINER & PUMP*
No Water Control Valve	O	S	P	B
Motorized 2-Way Shut-Off Valve	M	Y		
Motorized 3-Way Shut-Off Valve	N	V		

*Only available with Single Riser Cabinet (VST)

MISC. OPTIONS

0 = None
 S = Quiet Chassis
 C = Washer-less Hose Conn.
 B = Quiet Chassis w/ Washer-less Hose Conn.

WATERSIDE OPTIONS

C = Standard Water Coil
 N = Cupro-Nickel Water Coil

AIRSIDE OPTIONS

A = Standard Airside Coil
 C = Corrosion Protective Coating

AUTO-FLOW REGULATOR

0 = No Flow Control Valve
 B = 1.5 USGPM
 C = 2.0 USGPM
 D = 2.5 USGPM
 E = 3.0 USGPM
 F = 3.5 USGPM
 H = 4.0 USGPM
 J = 4.5 USGPM
 K = 5.0 USGPM
 L = 6.0 USGPM
 M = 7.0 USGPM
 N = 8.0 USGPM
 P = 9.0 USGPM
 R = 10.0 USGPM

Approvals



Table Of Contents

NOMENCLATURE	2
APPROVALS	3
TABLE OF CONTENTS	4
INTRODUCTION	5
PRODUCT OVERVIEW	6
STANDARD AND OPTIONAL FEATURES	7
PHYSICAL DATA	11
AHRI/ISO 13256-1 PERFORMANCE DATA	12
PERFORMANCE DATA - PSC MOTOR	13
PERFORMANCE DATA - EC MOTOR (ECM)	20
PERFORMANCE DATA	27
RISER SELECTION AND DATA	28
BLOWER PERFORMANCE	29
ELECTRICAL DATA	31
DIMENSIONAL DATA	33
HOSE KITS - NPSH WATER CONNECTION	41
HOSE KITS - JIC WATER CONNECTION	42
DISCHARGE CONFIGURATIONS	43
WIRING DIAGRAM	46
SPECIFICATIONS	49

Introduction

Performance, Value and Stainability in a Labor-Saving Package.

The Vertical Stacked Water Source Heat Pumps (VSCS) from Johnson Controls offer the ultimate in multi-story HVAC design flexibility. The VSCS Series is a compact, concealed system, capable of providing total heating and cooling functions for a single zone or multiple rooms. These units offer the flexibility of a four-pipe fan coil system at the cost of a two-pipe system, with the added flexibility of individual tenant metering. VSCS Series units are ideally suited for the total heating and cooling needs of any two-plus story building with a consistent floor plan.

- Hotels
- High-Rise Apartments / Condominiums
- Hospitals / Nursing homes
- Dormitories
- Renovated office space

The space saving VSCS unit is a two-part system featuring a self-supporting, pre-piped cabinet, and a removable heat pump chassis. The cabinet, complete with supply/return/drain risers, is installed during the intermediate phase of building construction. The cabinet is framed-in, and covered with drywall, as part of the interior wall structure. The finished equipment installation is hidden from view, blending with the decor of the room. Access to the mechanical components of the unit can be made entirely through the front/return air panel.

The provision for as many as three cabinet supply air outlets allows for maximum design flexibility and cost savings. One strategically located unit can serve up to three separate rooms without the need for ductwork. The ease of removal and replacement of the heat pump chassis offers enhanced serviceability. A chassis that requires service may be quickly removed, replaced with a back-up chassis, and serviced at a more convenient time or place.

All units are tested and certified by AHRI / ISO 13256-1 and ETL for United States and Canada. Johnson Controls stacked heat pump design exceeds ASHRAE 90.1 requirements at all rating conditions, making the VSCS series an excellent choice for water-loop and geothermal applications.

Product Overview

Refrigerant

R-410A

Sizes

0.75 – 3 Tons (2.6 – 10.6 kW)

Models Available

Cabinets:

VSB	Standard Assembly
VSM	Master Assembly
VSS	Slave Assembly
VST	Standard Single Riser Assembly

Chassis:

VSCS	Heat Pump Assembly
------	--------------------



Features

1. Terminal box
2. Double-deflection discharge grille (optional: opposed blade damper)
3. Sight/sound discharge baffles on all horizontal openings
4. Type M copper risers (optional: Type L)
5. Non-fused electrical disconnect
6. EC motor
7. Microprocessor control box
8. Stainless steel braided hoses
9. Copper tube aluminum fin refrigerant-to-air coil
10. MERV 4 throw-away filter (optional: MERV 8)
11. ASHRAE 62.1 compliant removable double-sloped drain pan (optional: stainless steel)
12. Acoustic perimeter return air intake door (locking options available)

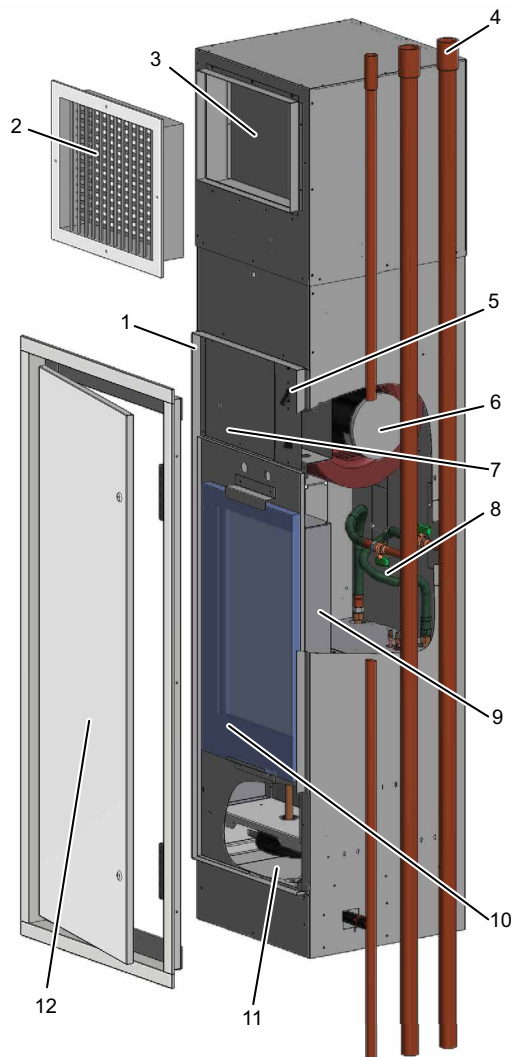

Standard and Optional Features

STANDARD FEATURES

Construction

- AHRI/ISO 13256-1 certified and labeled
- Galvanized steel construction
- ½” thick fiberglass insulation
- Integral filter rack with 1” throwaway filter

Decorator Front Panel

- Perimeter intake return air door
- Durable powder coat paint
- Magnetic latches

Supply Air

- Front, back, side, and/or top outlets
- Sight and sound baffles

Air-to-Refrigerant Coils

- R-410A direct expansion air coil
- 3/8” O.D. seamless copper tubes
- High efficiency aluminum fin surface for optimizing heat transfer, pressure drop, and carryover
- Easily removable for service

Water-to-Refrigerant Coils

- Coaxial heat exchanger with convoluted inner tube design
- Capable of operation with an entering fluid temperature range of 20°F to 110°F
- Riser connection with stainless steel braided hoses

Drain Pans

- Single wall, galvanized steel
- Fully insulated
- P-trap factory installed
- Condensate switch

Standard and Optional Features (Cont'd)

Fan Assemblies

- Forward curved, DWDI centrifugal type blowers
- 208/230V & 265V, single phase, PSC motors

Electrical

- cETL listed for safety compliance
- Electrical enclosure with access door for field wiring terminations
- Microprocessor controller handles reversing valve operation (no heat pump thermostat needed)
- Terminal block for field connections
- Single point power connection

OPTIONAL FEATURES

Construction

- Master/Slave arrangements
- 1" MERV 8 filter

Decorator Front Panel

- Quarter turn or key lock

Supply Air

- Double deflection discharge grille
- Opposed blade damper

Outside Air

- 4" round connection on top left/right of cabinet
- Motorized damper

Drain Pans

- Stainless steel construction

Fan Assemblies

- EC motors on all model sizes
- High-static PSC and EC motors

Electrical

- Non-fused disconnect or disconnect with fusing

Piping Options

- 2-way and 3-way motorized valves
- Fixed flow control valves
- P/T ports and Y-strainers

Thermostats

- Digital display
- Non-programmable or programmable
- Fan speed control
- ADA height thermostat mounting
- Communicating thermostat options

Risers

- Type M or L copper with swaged connections
- $\frac{3}{4}$ " to 3" diameters
- $\frac{1}{2}$ " and $\frac{3}{4}$ " closed cell insulation
- Type M copper condensate riser
- Riser extensions
- Riser cover
- Ship in advance risers

THIS PAGE INTENTIONALLY LEFT BLANK.

Physical Data

TABLE 1 - VSCS SERIES

MODEL SERIES	09	12	15	18	24	30	36
Nominal Cooling (Ton) ¹	0.75	1.0	1.25	1.5	2.0	2.5	3.0
COMPRESSOR TYPE	ROTARY			SCROLL			
Refrigerant Charge (Oz)	23	31	35	40	46	50	52
AIR COIL-TYPE	ENHANCED COPPER TUBES, ENHANCED ALUMINUM FINS						
Face Area (Sq Ft)	1.46	1.56	2.35	2.35	2.63	3.33	3.33
Rows/Fpi	2/16	3/14	3/14	3/14	3/14	3/14	3/14
WATER COIL-TYPE	ENHANCED SURFACE CO-AXIAL						
Psc Blower/Motor	DWDI FORWARD-CURVED CENTRIFUGAL / PSC DIRECT-DRIVE						
Diameter X Width (In)	9x4T	9x4T	9x7T	9x7T	9x7	9x8	9x8
Motor Hp	0.10	0.10	0.17	0.17	0.25	0.33	0.50
HI-STATIC PSC BLOWER/MOTOR	DWDI FORWARD-CURVED CENTRIFUGAL / PSC DIRECT-DRIVE						
Diameter X Width (In)	9x4T	9x4T	9x7T	9x7T	10x7T	10x8T	10x8T
Motor Hp	0.10	0.10	0.17	0.25	0.33	0.33	0.50
ECM BLOWER/MOTOR	DWDI FORWARD-CURVED CENTRIFUGAL / ECM DIRECT-DRIVE						
Diameter X Width (In)	9x4T	9x4T	9x7T	9x7T	10x7T	9x8	9x8
Motor Hp	0.33	0.33	0.33	0.33	0.33	0.50	0.50
HI-STATIC ECM BLOWER/MOTOR	DWDI FORWARD-CURVED CENTRIFUGAL / ECM DIRECT-DRIVE						
Diameter X Width (In)	9x4T	9x4T	9x7T	9x7T	10x7T	10x8T	10x8T
Motor Hp	0.33	0.33	0.33	0.33	0.33	0.50	0.50
Filter Quantity-Size (In)	1-14x25x1	1-14x25x1	1-16x30x1	1-16x30x1	1-16x30x1	1-20x30x1	1-20x30x1
Cabinet Weight (Lb) ²	130	130	145	145	150	175	175
Chassis Weight (Lb)	70	75	95	100	140	155	160

NOTE:

- Nominal Capacity calculated in accordance with AHRI / ISO Standard 13256-1 for Water Loop Application
- Cabinet weight is approximate and does not include weight of risers

TABLE 2 - OPERATING LIMITS*

	COOLING	HEATING
MIN. ENTERING WATER	30 °F	20 °F
MAX. ENTERING WATER	110 °F	90 °F

*Units are capable of operation with an entering fluid temperature range of 20 °F to 110 °F

AHRI/ISO 13256-1 Performance Data

TABLE 3 - PSC MOTORS

MODEL	FLOW RATE (USGPM)	AIR FLOW (SCFM)	WATER LOOP CONDITIONS ¹			GROUND WATER CONDITIONS ²				GROUND LOOP CONDITIONS ³				
			COOLING		HEATING	COOLING		HEATING	COOLING		HEATING			
			CAPACITY (BTUH) ⁴	EER	CAPACITY (BTUH) ⁵	COP	CAPACITY (BTUH) ⁴	EER	CAPACITY (BTUH) ⁵	COP	CAPACITY (BTUH) ⁴	EER	CAPACITY (BTUH) ⁵	COP
09	2.6	340	8,900	13.0	11,800	4.5	10,100	19.5	9,300	3.8	9,300	14.2	7,000	3.2
12	3.2	430	12,200	13.0	14,900	4.4	14,400	19.8	12,200	3.7	12,600	14.3	9,700	3.2
15	4.0	550	14,500	13.5	17,200	4.7	16,500	21.8	13,900	4.0	14,500	16.0	10,900	3.3
18	4.8	685	18,100	13.2	22,300	4.6	20,800	20.6	18,000	3.9	18,800	14.5	14,000	3.2
24	6.2	850	24,400	13.4	30,200	4.5	28,100	21.5	23,800	3.9	26,000	15.7	18,500	3.2
30	7.8	1075	30,000	13.5	34,900	4.6	33,500	20.0	27,500	3.7	31,800	15.2	20,500	3.2
36	9.5	1220	34,900	13.0	43,000	4.3	39,200	19.4	29,100	3.7	36,400	14.1	22,900	3.2

TABLE 4 - EC MOTORS (ECM)

MODEL	FLOW RATE (USGPM)	AIR FLOW (SCFM)	WATER LOOP CONDITIONS ¹			GROUND WATER CONDITIONS ²				GROUND LOOP CONDITIONS ³				
			COOLING		HEATING	COOLING		HEATING	COOLING		HEATING			
			CAPACITY (BTUH) ⁴	EER	CAPACITY (BTUH) ⁵	COP	CAPACITY (BTUH) ⁴	EER	CAPACITY (BTUH) ⁵	COP	CAPACITY (BTUH) ⁴	EER	CAPACITY (BTUH) ⁵	COP
09	2.6	340	9,100	14.0	11,600	4.6	10,200	20.0	9,100	4.0	9,400	14.4	6,800	3.3
12	3.2	430	12,300	13.4	14,700	4.5	14,600	20.2	12,000	3.8	12,800	14.5	9,400	3.3
15	4.0	550	14,600	14.0	17,100	4.8	16,600	22.0	13,800	4.1	14,800	16.2	10,600	3.4
18	4.8	685	18,400	13.6	22,000	4.7	20,900	21.0	18,100	4.0	19,100	15.1	13,700	3.3
24	6.2	850	24,600	13.7	30,000	4.6	28,200	21.7	24,000	4.0	26,100	16.1	17,900	3.3
30	7.8	1075	30,100	13.8	34,400	4.7	33,900	20.6	27,100	3.9	32,200	15.6	20,100	3.3
36	9.5	1220	35,500	13.3	42,700	4.5	39,800	19.8	28,100	3.9	37,000	14.5	21,900	3.3

NOTES:

1. Water Loop capacities are rated at 86°F EWT Cooling, 68 °F EWT Heating.
2. Ground Water capacities are rated at 59°F EWT Cooling, 50 °F EWT Heating.
3. Ground Loop capacities are rated at 77°F EFT Cooling, 32 °F EFT Heating.
4. All Cooling capacities based upon 80.6°F DB, 66.2 °F WB entering air temperature.
5. All Heating capacities based upon 68°F DB, 59 °F WB entering air temperature.

Performance Data - PSC Motor

TABLE 5 - VSCS09 - PSC MOTOR - 340 CFM

EWT	GPM	WPD		COOLING						HEATING				
		PSI	FT	TC	SC	SHR	KW	HR	EER	HTG	KW	HE	LAT	COP
20	2.6	6.8	15.7							5.3	0.59	3.7	82.4	2.6
30	1.3	1.8	4.2	11.1	7.3	0.66	0.46	12.3	24.4	6.4	0.61	4.7	85.4	3.1
	2.0	4.1	9.4	11.4	7.6	0.67	0.43	12.4	26.7	6.8	0.62	5.1	86.5	3.2
	2.6	6.7	15.3	11.7	8.1	0.69	0.41	12.7	28.3	7.0	0.65	5.2	87.1	3.2
40	1.3	1.7	3.8	10.4	7.1	0.68	0.51	11.7	20.4	7.4	0.63	5.7	88.1	3.4
	2.0	3.7	8.5	10.5	7.3	0.69	0.48	11.8	21.7	7.7	0.66	5.9	88.9	3.4
	2.6	6.0	13.9	10.9	7.7	0.71	0.46	12.0	23.5	8.1	0.67	6.2	90.0	3.5
50	1.3	1.5	3.4	10.0	7.0	0.70	0.57	11.5	17.7	8.5	0.67	6.7	91.1	3.7
	2.0	3.3	7.6	10.1	7.2	0.71	0.54	11.5	18.7	9.0	0.69	7.1	92.4	3.8
	2.6	5.4	12.4	10.4	7.6	0.73	0.52	11.7	20.2	9.3	0.70	7.3	93.3	3.9
60	1.3	1.4	3.3	9.6	7.0	0.73	0.65	11.4	14.8	9.7	0.69	7.7	94.3	4.1
	2.0	3.1	7.3	9.8	7.2	0.74	0.63	11.5	15.5	10.2	0.71	8.2	95.7	4.2
	2.6	5.1	11.8	10.1	7.6	0.75	0.56	11.6	18.2	10.7	0.72	8.6	97.1	4.3
70	1.3	1.3	3.1	9.2	6.7	0.73	0.73	11.3	12.6	10.7	0.69	8.8	97.1	4.5
	2.0	3.0	6.9	9.3	6.9	0.74	0.72	11.3	13.0	11.2	0.71	9.2	98.5	4.6
	2.6	4.9	11.2	9.6	7.3	0.76	0.61	11.2	15.9	11.9	0.73	9.8	100.4	4.8
80	1.3	1.3	2.9	8.8	6.7	0.76	0.80	11.2	11.0	12.4	0.72	10.4	101.8	5.1
	2.0	2.8	6.5	8.9	6.9	0.77	0.77	11.1	11.6	12.7	0.72	10.7	102.6	5.2
	2.6	4.6	10.6	9.2	7.1	0.77	0.67	11.0	13.8	13.1	0.73	11.0	103.7	5.3
90	1.3	1.2	2.8	8.5	6.4	0.76	0.88	11.0	9.7	13.8	0.74	11.7	105.6	5.5
	2.0	2.7	6.2	8.5	6.5	0.77	0.83	10.9	10.2	14.5	0.75	12.4	107.5	5.7
	2.6	4.4	10.1	8.7	6.7	0.78	0.70	10.6	12.4	14.8	0.76	12.6	108.3	5.7
100	1.3	1.1	2.5	8.1	6.2	0.77	0.97	11.0	8.4					
	2.0	2.6	6.0	8.2	6.4	0.78	0.92	11.0	8.9					
	2.6	4.3	9.9	8.4	6.6	0.79	0.86	10.9	9.7					
110	1.3	1.1	2.5	7.8	6.1	0.79	1.06	10.9	7.3					
	2.0	2.5	5.8	8.0	6.3	0.79	1.02	11.0	7.9					
	2.6	4.2	9.7	8.1	6.5	0.80	0.99	11.1	8.2					

- Cooling Performance is tabulated at 80.6 °F DB and 66.2 °F WB entering air. Heating performance tabulated at 68 °F EAT
- Tabulated data does not include AHRI/ISO corrections for fan and pump power.
- All capacities are expressed in MBH.
- Insulated water circuit is recommended for operation below 60 °F EWT.
- See performance correction tables for conditions beyond what is listed.
- Extrapolation is not permissible.
- Blank areas indicate conditions where operation is not recommended.

Performance Data - PSC Motor (Cont'd)

TABLE 6 - VSCS12 - PSC MOTOR - 430 CFM

EWT	GPM	WPD		COOLING						HEATING				
		PSI	FT	TC	SC	SHR	KW	HR	EER	HTG	KW	HE	LAT	COP
20	3.2	6.5	15.0							7.9	0.82	5.6	85.0	2.8
30	1.6	1.7	4.0	15.3	10.4	0.68	0.66	17.0	23.2	9.1	0.90	6.6	87.5	3.0
	2.4	3.7	8.5	15.6	10.7	0.69	0.62	17.1	25.3	9.3	0.91	6.7	88.0	3.0
	3.2	6.3	14.5	16.0	11.2	0.70	0.60	17.5	26.9	9.5	0.92	7.0	88.6	3.1
40	1.6	1.6	3.7	14.9	10.6	0.71	0.72	16.8	20.6	10.2	0.90	7.7	89.9	3.3
	2.4	3.4	7.9	15.3	10.9	0.71	0.68	17.1	22.5	10.6	0.91	8.0	90.9	3.4
	3.2	5.9	13.5	15.5	11.2	0.72	0.64	17.2	24.2	10.9	0.92	8.3	91.4	3.5
50	1.6	1.5	3.5	13.9	9.9	0.71	0.78	16.0	17.7	11.5	0.96	8.8	92.8	3.5
	2.4	3.2	7.3	14.3	10.3	0.72	0.72	16.2	19.9	11.9	0.98	9.1	93.6	3.6
	3.2	5.4	12.5	14.8	10.8	0.73	0.70	16.6	21.2	12.2	0.99	9.4	94.3	3.6
60	1.6	1.4	3.3	13.2	9.5	0.72	0.86	15.6	15.4	12.7	0.95	10.0	95.4	3.9
	2.4	3.0	6.9	13.5	9.9	0.73	0.80	15.7	16.8	13.2	0.96	10.4	96.4	4.0
	3.2	5.1	11.8	14.3	10.6	0.74	0.73	16.3	19.6	13.6	0.96	10.9	97.3	4.2
70	1.6	1.3	3.0	12.4	9.1	0.73	0.99	15.3	12.6	13.9	0.97	11.1	97.9	4.2
	2.4	2.8	6.5	12.8	9.4	0.74	0.92	15.4	13.9	14.5	0.98	11.7	99.2	4.3
	3.2	4.9	11.3	12.9	9.7	0.75	0.86	15.4	15.1	15.0	0.98	12.2	100.3	4.5
80	1.6	1.3	3.0	11.5	8.6	0.75	1.04	14.5	11.1	15.4	0.99	12.6	101.2	4.6
	2.4	2.7	6.2	11.7	9.0	0.77	0.96	14.5	12.3	16.0	1.01	13.1	102.5	4.6
	3.2	4.7	10.8	12.4	9.8	0.79	0.87	14.9	14.3	16.5	1.01	13.5	103.4	4.8
90	1.6	1.2	2.9	11.0	8.3	0.76	1.16	14.4	9.5	16.9	1.03	13.9	104.4	4.8
	2.4	2.6	6.1	11.3	8.7	0.77	1.07	14.4	10.6	17.6	1.04	14.6	105.9	5.0
	3.2	4.5	10.4	11.8	9.3	0.79	0.98	14.6	12.1	18.1	1.04	15.1	107.0	5.1
100	1.6	1.2	2.7	10.0	7.7	0.77	1.24	13.7	8.1					
	2.4	2.5	5.8	10.5	8.2	0.78	1.18	13.9	8.9					
	3.2	4.4	10.2	10.6	8.4	0.79	1.12	13.9	9.4					
110	1.6	1.1	2.5	9.5	7.4	0.78	1.35	13.6	7.0					
	2.4	2.4	5.5	9.9	7.7	0.78	1.30	13.8	7.6					
	3.2	4.3	9.9	10.1	7.9	0.79	1.25	13.8	8.0					

- Cooling Performance is tabulated at 80.6 °F DB and 66.2 °F WB entering air. Heating performance tabulated at 68 °F EAT
- Tabulated data does not include AHRI/ISO corrections for fan and pump power.
- All capacities are expressed in MBH.
- Insulated water circuit is recommended for operation below 60 °F EWT.
- See performance correction tables for conditions beyond what is listed.
- Extrapolation is not permissible.
- Blank areas indicate conditions where operation is not recommended.

TABLE 7 - VSCS15 - PSC MOTOR - 550 CFM

EWT	GPM	WPD		COOLING						HEATING				
		PSI	FT	TC	SC	SHR	KW	HR	EER	HTG	KW	HE	LAT	COP
20	4.0	7.0	16.2							8.8	0.93	6.4	84.3	2.8
30	2.0	1.9	4.5	18.6	13.8	0.74	0.69	20.3	26.9	9.7	0.98	7.0	85.7	2.9
	3.0	4.1	9.5	18.8	14.1	0.75	0.63	20.2	29.7	10.5	0.79	8.5	86.2	3.9
	4.0	7.0	16.2	18.8	14.3	0.76	0.59	20.1	31.8	10.8	1.01	8.1	88.1	3.1
40	2.0	1.9	4.3	18.1	14.0	0.77	0.76	20.0	23.9	11.9	1.01	9.2	88.7	3.4
	3.0	4.0	9.1	18.5	14.3	0.77	0.70	20.1	26.5	12.3	1.03	9.5	89.3	3.5
	4.0	6.7	15.6	18.3	14.3	0.78	0.64	19.7	28.6	12.7	1.04	9.8	90.4	3.6
50	2.0	1.8	4.1	16.9	12.7	0.75	0.83	19.0	20.5	13.3	1.05	10.5	91.4	3.7
	3.0	3.8	8.7	17.2	12.9	0.75	0.74	19.0	23.2	13.9	1.05	11.1	92.0	3.9
	4.0	6.5	14.9	17.3	13.2	0.76	0.69	19.0	25.0	14.3	1.06	11.4	93.3	4.0
60	2.0	1.6	3.6	15.9	12.1	0.76	0.89	18.2	18.0	15.0	1.06	12.2	94.2	4.2
	3.0	3.3	7.7	16.1	12.3	0.76	0.83	18.2	19.5	15.6	1.06	12.7	94.9	4.3
	4.0	5.7	13.1	16.3	12.4	0.76	0.80	18.3	20.4	16.0	1.07	13.0	95.5	4.4
70	2.0	1.4	3.3	15.0	11.7	0.78	0.98	17.6	15.2	16.3	1.06	13.4	96.6	4.5
	3.0	3.1	7.0	15.2	12.1	0.79	0.94	17.7	16.2	17.0	1.08	14.1	97.6	4.6
	4.0	5.2	12.0	15.4	12.2	0.79	0.91	17.7	16.8	17.6	1.09	14.6	98.5	4.5
80	2.0	1.4	3.2	14.3	11.5	0.80	1.08	17.2	13.2	18.1	1.11	15.1	99.3	4.8
	3.0	2.9	6.7	14.5	11.6	0.80	1.04	17.3	13.9	18.6	1.12	15.5	100.0	4.8
	4.0	5.0	11.4	14.5	11.7	0.80	1.02	17.3	14.3	19.0	1.15	15.8	100.3	4.8
90	2.0	1.3	3.0	13.6	11.1	0.82	1.18	16.9	11.4	19.2	1.16	16.0	101.0	4.9
	3.0	2.8	6.4	13.8	11.3	0.82	1.13	16.9	12.2	19.6	1.17	16.3	101.3	4.9
	4.0	4.7	10.9	13.9	11.5	0.83	1.13	17.0	12.4	19.8	1.18	16.5	68.0	4.9
100	2.0	1.2	2.8	12.8	10.6	0.83	1.30	16.5	9.8					
	3.0	2.6	6.0	13.0	10.9	0.84	1.26	16.6	10.3					
	4.0	4.4	10.2	13.2	11.1	0.84	1.24	16.7	10.6					
110	2.0	1.1	2.6	12.0	10.3	0.86	1.45	16.3	8.3					
	3.0	2.5	5.8	12.3	10.7	0.87	1.40	16.4	8.8					
	4.0	4.5	10.3	12.5	10.8	0.87	1.38	16.5	9.1					

- Cooling Performance is tabulated at 80.6 °F DB and 66.2 °F WB entering air. Heating performance tabulated at 68 °F EAT
- Tabulated data does not include AHRI/ISO corrections for fan and pump power.
- All capacities are expressed in MBH.
- Insulated water circuit is recommended for operation below 60 °F EWT.
- See performance correction tables for conditions beyond what is listed.
- Extrapolation is not permissible.
- Blank areas indicate conditions where operation is not recommended.

Performance Data - PSC Motor (Cont'd)

TABLE 8 - VSCS18 - PSC MOTOR - 685 CFM

EWT	GPM	WPD		COOLING						HEATING				
		PSI	FT	TC	SC	SHR	KW	HR	EER	HTG	KW	HE	LAT	COP
20	4.8	7.5	17.3							11.4	1.29	7.7	83.4	2.6
30	2.4	2.0	4.7	22.2	15.1	0.68	0.75	24.0	29.7	13.0	1.30	9.3	85.6	2.9
	3.6	4.3	9.9	22.3	15.2	0.68	0.72	24.0	31.1	13.5	1.30	9.8	86.2	3.1
	4.8	7.3	16.8	22.6	15.6	0.69	0.69	24.2	33.0	13.9	1.32	10.2	86.8	3.1
40	2.4	1.9	4.5	21.3	14.9	0.70	0.88	23.6	24.2	14.6	1.30	10.9	87.7	3.3
	3.6	4.1	9.5	21.5	15.3	0.71	0.83	23.6	25.9	14.9	1.31	11.2	88.2	3.4
	4.8	7.0	16.1	21.9	15.8	0.72	0.80	23.9	27.5	15.5	1.33	11.7	88.9	3.4
50	2.4	1.9	4.3	20.5	14.8	0.72	0.98	23.1	20.9	16.6	1.31	12.9	90.5	3.7
	3.6	3.9	9.1	21.5	15.7	0.73	0.91	23.9	23.5	17.3	1.32	13.5	91.4	3.8
	4.8	6.7	15.5	21.3	15.5	0.73	0.88	23.5	24.3	18.0	1.33	14.2	92.3	4.0
60	2.4	1.6	3.8	19.7	14.4	0.73	1.14	22.8	17.3	19.0	1.32	15.2	93.6	4.2
	3.6	3.5	8.0	20.5	14.9	0.73	1.07	23.3	19.2	19.8	1.34	15.9	94.7	4.3
	4.8	5.9	13.6	20.8	15.4	0.74	1.02	23.5	20.4	20.3	1.37	16.4	95.5	4.4
70	2.4	1.5	3.5	18.9	14.1	0.75	1.29	22.5	14.6	21.2	1.34	17.3	96.6	4.6
	3.6	3.2	7.3	19.1	14.5	0.76	1.22	22.5	15.7	22.1	1.36	18.2	97.9	4.8
	4.8	5.4	12.5	19.4	14.9	0.77	1.18	22.7	16.4	22.8	1.39	18.8	98.8	4.8
80	2.4	1.4	3.3	17.8	13.4	0.75	1.45	22.0	12.3	23.2	1.35	19.3	99.4	5.0
	3.6	3.0	7.0	18.2	14.0	0.77	1.36	22.1	13.3	24.2	1.38	20.3	100.7	5.2
	4.8	5.2	11.9	18.6	14.7	0.79	1.27	22.1	14.7	25.2	1.40	21.2	102.1	5.3
90	2.4	1.4	3.1	17.0	13.1	0.77	1.64	21.9	10.4	24.9	1.37	21.0	101.7	5.3
	3.6	2.9	6.6	17.4	13.6	0.78	1.55	22.0	11.3	25.8	1.39	21.8	102.9	5.4
	4.8	4.9	11.3	17.8	14.1	0.79	1.46	22.0	12.2	27.7	1.41	23.6	105.4	5.7
100	2.4	1.3	3.0	15.8	12.3	0.78	1.82	21.2	8.6					
	3.6	2.8	6.5	16.3	12.7	0.78	1.72	21.4	9.4					
	4.8	4.8	11.1	17.0	13.4	0.79	1.67	22.0	10.2					
110	2.4	1.2	2.8	14.9	11.6	0.78	2.08	21.2	7.2					
	3.6	2.7	6.2	15.4	12.2	0.79	1.96	21.3	7.9					
	4.8	4.7	10.8	16.2	13.0	0.80	1.90	22.0	8.5					

- Cooling Performance is tabulated at 80.6 °F DB and 66.2 °F WB entering air. Heating performance tabulated at 68 °F EAT
- Tabulated data does not include AHRI/ISO corrections for fan and pump power.
- All capacities are expressed in MBH.
- Insulated water circuit is recommended for operation below 60 °F EWT.
- See performance correction tables for conditions beyond what is listed.
- Extrapolation is not permissible.
- Blank areas indicate conditions where operation is not recommended.

TABLE 9 - VSCS24 - PSC MOTOR - 850 CFM

EWT	GPM	WPD		COOLING						HEATING				
		PSI	FT	TC	SC	SHR	KW	HR	EER	HTG	KW	HE	LAT	COP
20	6.2	6.6	15.2							13.9	1.64	9.3	83.1	2.5
30	3.1	1.7	4.0	29.2	19.3	0.66	1.12	32.1	26.1	15.7	1.65	11.0	85.1	2.8
	4.6	3.6	8.3	29.4	20.0	0.68	1.08	32.2	27.2	17.2	1.66	12.5	86.7	3.0
	6.2	6.3	14.4	29.6	20.4	0.69	1.05	32.3	28.3	17.5	1.67	12.8	87.1	3.1
40	3.1	1.6	3.6	29.0	19.7	0.68	1.23	32.3	23.5	18.8	1.68	14.0	88.5	3.3
	4.6	3.3	7.5	29.1	20.1	0.69	1.18	32.2	24.8	20.2	1.71	15.3	90.0	3.5
	6.2	5.6	13.0	29.2	20.5	0.70	1.12	32.1	26.2	20.7	1.73	15.7	90.5	3.5
50	3.1	1.4	3.2	28.1	19.4	0.69	1.33	31.7	21.1	21.9	1.73	17.0	91.9	3.7
	4.6	2.9	6.7	28.3	19.8	0.70	1.26	31.7	22.5	23.0	1.80	17.8	93.1	3.8
	6.2	5.0	11.6	28.5	20.2	0.71	1.20	31.6	23.8	23.8	1.82	18.5	93.9	3.8
60	3.1	1.3	3.0	27.0	19.2	0.71	1.52	31.2	17.8	24.7	1.80	19.5	94.9	4.0
	4.6	2.7	6.2	27.3	19.6	0.72	1.40	31.1	19.5	26.1	1.81	20.9	96.4	4.2
	6.2	4.7	10.8	27.6	20.1	0.73	1.29	31.0	21.3	27.4	1.85	22.0	97.8	4.3
70	3.1	1.3	2.9	26.0	18.7	0.72	1.71	30.8	15.2	27.5	1.83	22.2	98.0	4.4
	4.6	2.6	6.0	26.4	19.0	0.72	1.60	30.9	16.5	29.2	1.84	23.9	99.8	4.6
	6.2	4.5	10.4	26.8	19.9	0.74	1.50	31.0	17.9	30.8	1.88	25.3	101.5	4.8
80	3.1	1.2	2.8	24.3	17.7	0.73	1.91	29.8	12.7	30.2	1.87	24.8	100.9	4.7
	4.6	2.5	5.8	25.0	18.2	0.73	1.80	30.2	13.8	32.3	1.90	26.8	103.2	5.0
	6.2	4.3	10.0	25.6	18.9	0.74	1.74	30.5	14.7	33.6	1.95	27.9	104.6	5.0
90	3.1	1.1	2.5	22.7	16.6	0.73	2.14	29.1	10.6	33.8	1.95	28.1	104.8	5.1
	4.6	2.4	5.5	23.2	17.1	0.74	2.02	29.1	11.5	35.6	2.04	29.6	106.8	5.1
	6.2	4.2	9.7	23.7	18.0	0.76	1.89	29.1	12.5	36.8	2.08	30.7	108.1	5.2
100	3.1	1.1	2.5	21.2	16.1	0.76	2.42	28.5	8.8					
	4.6	2.3	5.3	21.7	16.5	0.76	2.28	28.5	9.5					
	6.2	4.2	9.7	22.1	17.0	0.77	2.17	28.5	10.2					
110	3.1	1.0	2.3	19.8	15.2	0.77	2.70	28.1	7.3					
	4.6	2.3	5.3	20.3	15.6	0.77	2.57	28.1	7.9					
	6.2	4.1	9.5	20.6	16.1	0.78	2.44	28.0	8.4					

- Cooling Performance is tabulated at 80.6 °F DB and 66.2 °F WB entering air. Heating performance tabulated at 68 °F EAT
- Tabulated data does not include AHRI/ISO corrections for fan and pump power.
- All capacities are expressed in MBH.
- Insulated water circuit is recommended for operation below 60 °F EWT.
- See performance correction tables for conditions beyond what is listed.
- Extrapolation is not permissible.
- Blank areas indicate conditions where operation is not recommended.

Performance Data - PSC Motor (Cont'd)

TABLE 10 - VSCS30 - PSC MOTOR - 1075 CFM

EWT	GPM	WPD		COOLING						HEATING				
		PSI	FT	TC	SC	SHR	KW	HR	EER	HTG	KW	HE	LAT	COP
20	3.9	5.6	12.9							17.4	1.89	12.0	82.9	2.7
30	3.9	1.5	3.5	34.8	23.7	0.68	1.37	38.3	25.4	20.4	1.92	15.0	85.6	3.1
	5.8	3.1	7.2	35.3	24.4	0.69	1.35	38.8	26.2	21.1	1.95	15.6	86.2	3.2
	7.8	5.4	12.5	35.6	24.9	0.70	1.33	39.0	26.8	21.9	1.96	16.4	86.9	3.3
40	3.9	1.4	3.2	35.3	24.3	0.69	1.45	39.1	24.3	21.9	1.98	16.3	86.9	3.2
	5.8	2.9	6.6	35.7	25.4	0.71	1.41	39.4	25.3	22.9	2.04	17.0	87.7	3.3
	7.8	5.0	11.4	35.8	25.8	0.72	1.37	39.4	26.1	23.8	2.09	17.8	88.5	3.3
50	3.9	1.2	2.9	34.0	24.5	0.72	1.52	38.1	22.4	25.3	2.08	19.3	89.8	3.6
	5.8	2.6	6.0	34.4	25.1	0.73	1.48	38.3	23.3	26.5	2.16	20.3	90.9	3.6
	7.8	4.5	10.4	34.5	25.5	0.74	1.46	38.3	23.7	28.6	2.21	22.2	92.6	3.8
60	3.9	1.2	2.8	32.9	24.0	0.73	1.72	37.7	19.2	29.5	2.14	23.3	93.4	4.0
	5.8	2.5	5.8	33.4	24.7	0.74	1.68	38.0	19.9	31.1	2.20	24.7	94.8	4.1
	7.8	4.3	10.0	33.4	24.7	0.74	1.64	37.9	20.3	32.3	2.24	25.8	95.8	4.2
70	3.9	1.2	2.7	31.2	22.8	0.73	1.91	36.6	16.4	32.8	2.19	26.4	96.2	4.4
	5.8	2.4	5.6	31.7	23.5	0.74	1.83	36.8	17.3	34.5	2.24	28.0	97.7	4.5
	7.8	4.2	9.6	32.3	24.3	0.75	1.90	37.7	17.0	35.8	2.25	29.3	98.8	4.7
80	3.9	1.1	2.6	29.7	21.9	0.74	2.14	35.8	13.8	34.9	2.20	28.5	98.1	4.6
	5.8	2.3	5.4	30.2	22.7	0.75	2.06	36.1	14.7	36.1	2.25	29.5	99.1	4.7
	7.8	4.0	9.3	31.0	23.6	0.76	2.15	37.2	14.5	36.9	2.26	30.4	99.8	4.8
90	3.9	1.0	2.4	28.1	21.1	0.75	2.38	35.1	11.8	36.4	2.22	29.9	99.4	4.8
	5.8	2.2	5.0	28.7	21.8	0.76	2.35	35.6	12.2	37.3	2.26	30.7	100.1	4.8
	7.8	3.8	8.7	28.8	22.2	0.77	2.30	35.5	12.5	37.7	2.27	31.1	100.5	4.9
100	3.9	1.3	3.0	25.2	19.2	0.76	2.67	33.2	9.5					
	5.8	2.1	4.8	26.2	20.2	0.77	2.56	33.8	10.3					
	7.8	3.7	8.5	26.6	20.8	0.78	2.49	34.0	10.7					
110	3.9	1.2	2.8	23.1	16.6	0.72	3.02	32.3	7.7					
	5.8	2.0	4.6	24.5	17.4	0.71	2.89	33.3	8.5					
	7.8	3.6	8.3	24.7	19.5	0.79	2.82	33.2	8.8					

- Cooling Performance is tabulated at 80.6 °F DB and 66.2 °F WB entering air. Heating performance tabulated at 68 °F EAT
- Tabulated data does not include AHRI/ISO corrections for fan and pump power.
- All capacities are expressed in MBH.
- Insulated water circuit is recommended for operation below 60 °F EWT.
- See performance correction tables for conditions beyond what is listed.
- Extrapolation is not permissible.
- Blank areas indicate conditions where operation is not recommended.

TABLE 11 - VSCS36 - PSC MOTOR - 1220 CFM

EWT	GPM	WPD		COOLING						HEATING				
		PSI	FT	TC	SC	SHR	KW	HR	EER	HTG	KW	HE	LAT	COP
20	9.5	9.1	21.0							20.1	2.19	14.1	83.3	2.7
30	4.8	2.6	6.0	42.4	29.3	0.69	1.68	46.7	25.2	22.8	2.29	16.5	85.3	2.9
	7.2	5.4	12.5	42.6	29.0	0.68	1.60	46.6	26.6	23.6	2.30	17.2	85.9	3.0
	9.5	8.5	19.6	42.8	28.6	0.67	1.58	46.7	27.1	24.2	2.31	17.8	86.4	3.1
40	4.8	2.5	5.8	41.2	30.0	0.73	1.81	45.9	22.7	26.6	2.31	20.2	88.2	3.4
	7.2	5.0	11.5	41.6	29.9	0.72	1.72	46.0	24.1	27.7	2.34	21.1	89.0	3.5
	9.5	8.0	18.5	42.0	29.4	0.70	1.68	46.3	25.0	28.6	2.35	22.0	89.7	3.6
50	4.8	2.3	5.3	39.2	29.0	0.74	1.91	44.3	20.5	30.3	2.35	23.7	91.0	3.8
	7.2	4.6	10.6	40.0	29.2	0.73	1.82	44.7	22.0	31.6	2.39	24.9	92.0	3.9
	9.5	7.4	17.1	40.5	29.1	0.72	1.77	45.0	22.9	32.1	2.58	24.8	92.4	3.7
60	4.8	2.1	4.8	37.3	27.6	0.74	2.18	43.3	17.1	33.2	2.62	25.7	93.2	3.7
	7.2	4.3	9.9	38.5	28.1	0.73	2.06	44.0	18.7	35.1	2.64	27.6	94.6	3.9
	9.5	6.9	15.9	39.1	28.5	0.73	2.00	44.4	19.6	36.6	2.65	29.0	95.8	4.0
70	4.8	2.0	4.6	35.0	26.6	0.76	2.44	41.9	14.3	37.6	2.66	30.0	96.5	4.1
	7.2	4.1	9.5	36.7	27.5	0.75	2.38	43.3	15.4	39.7	2.70	31.9	98.1	4.3
	9.5	6.6	15.2	37.5	27.7	0.74	2.30	43.9	16.3	40.6	2.72	32.8	98.8	4.4
80	4.8	1.8	4.2	33.5	26.1	0.78	2.80	41.6	12.0	40.6	2.77	32.6	98.8	4.3
	7.2	3.9	9.0	35.0	27.0	0.77	2.74	42.9	12.8	42.7	2.79	34.6	100.4	4.5
	9.5	6.3	14.5	35.9	27.1	0.76	2.60	43.3	13.8	43.7	2.80	35.6	101.2	4.6
90	4.8	1.7	3.9	31.9	25.2	0.79	3.14	41.2	10.2	43.6	2.82	35.4	101.1	4.5
	7.2	3.7	8.5	33.2	25.6	0.77	2.89	41.6	11.5	45.4	2.86	37.1	102.5	4.7
	9.5	6.0	13.8	34.2	26.1	0.76	2.78	42.2	12.3	46.3	2.88	37.9	103.1	4.7
100	4.8	1.6	3.7	29.5	23.3	0.79	3.31	39.3	8.9					
	7.2	3.8	8.8	30.9	24.1	0.78	3.11	40.1	9.9					
	9.5	5.8	13.4	31.8	24.8	0.78	3.00	40.5	10.6					
110	4.8	1.6	3.7	26.9	21.8	0.81	3.72	38.1	7.2					
	7.2	3.7	8.5	28.2	22.5	0.80	3.42	38.4	8.2					
	9.5	5.7	13.1	28.9	22.8	0.79	3.35	38.9	8.6					

- Cooling Performance is tabulated at 80.6 °F DB and 66.2 °F WB entering air. Heating performance tabulated at 68 °F EAT
- Tabulated data does not include AHRI/ISO corrections for fan and pump power.
- All capacities are expressed in MBH.
- Insulated water circuit is recommended for operation below 60 °F EWT.
- See performance correction tables for conditions beyond what is listed.
- Extrapolation is not permissible.
- Blank areas indicate conditions where operation is not recommended.

Performance Data - EC Motor (ECM)

TABLE 12 - VSCS09 - EC MOTOR (ECM) - 340 CFM

EWT	GPM	WPD		COOLING						HEATING				
		PSI	FT	TC	SC	SHR	KW	HR	EER	HTG	KW	HE	LAT	COP
20	2.6	6.8	15.7							5.1	0.54	3.5	81.9	2.8
30	1.3	1.8	4.2	11.3	7.5	0.66	0.40	12.4	28.2	6.2	0.56	4.6	84.9	3.3
	2.0	4.1	9.4	11.6	7.8	0.67	0.37	12.6	31.1	6.6	0.57	4.9	86.0	3.4
	2.6	6.7	15.3	11.9	8.3	0.69	0.36	12.9	33.2	6.8	0.59	5.0	86.6	3.4
40	1.3	1.7	3.8	10.6	7.3	0.68	0.46	11.9	23.3	7.2	0.58	5.5	87.6	3.7
	2.0	3.7	8.5	10.7	7.4	0.69	0.43	11.9	25.0	7.5	0.60	5.7	88.4	3.7
	2.6	6.0	13.9	11.1	7.9	0.71	0.41	12.2	27.1	7.9	0.62	6.0	89.5	3.8
50	1.3	1.5	3.4	10.2	7.2	0.70	0.51	11.7	19.9	8.3	0.61	6.5	90.6	4.0
	2.0	3.3	7.6	10.3	7.4	0.71	0.49	11.7	21.2	8.8	0.63	6.9	91.9	4.1
	2.6	5.4	12.4	10.6	7.8	0.73	0.46	11.9	23.0	9.1	0.64	7.2	92.8	4.1
60	1.3	1.4	3.3	9.8	7.2	0.73	0.59	11.6	16.5	9.5	0.63	7.6	93.8	4.4
	2.0	3.1	7.3	9.9	7.4	0.74	0.57	11.7	17.4	10.0	0.65	8.0	95.1	4.5
	2.6	5.1	11.8	10.3	7.8	0.75	0.50	11.8	20.6	10.5	0.66	8.5	96.5	4.6
70	1.3	1.3	3.1	9.4	6.9	0.73	0.68	11.5	13.9	10.5	0.64	8.6	96.6	4.9
	2.0	3.0	6.9	9.5	7.1	0.74	0.66	11.5	14.4	11.0	0.66	9.0	98.0	4.9
	2.6	4.9	11.2	9.8	7.5	0.76	0.55	11.4	17.8	11.7	0.68	9.6	99.9	5.1
80	1.3	1.3	2.9	9.0	6.9	0.76	0.75	11.4	12.1	12.2	0.66	10.2	101.3	5.4
	2.0	2.8	6.5	9.1	7.1	0.77	0.72	11.3	12.7	12.5	0.67	10.5	102.1	5.5
	2.6	4.6	10.6	9.4	7.3	0.77	0.61	11.2	15.4	12.9	0.68	10.8	103.2	5.6
90	1.3	1.2	2.8	8.6	6.6	0.76	0.82	11.2	10.5	13.6	0.69	11.5	105.1	5.8
	2.0	2.7	6.2	8.7	6.7	0.77	0.77	11.1	11.2	14.3	0.70	12.2	107.0	6.0
	2.6	4.4	10.1	8.8	6.9	0.78	0.65	10.8	13.7	14.6	0.71	12.4	107.8	6.1
100	1.3	1.1	2.5	8.3	6.4	0.77	0.91	11.2	9.1					
	2.0	2.6	6.0	8.4	6.6	0.78	0.87	11.2	9.7					
	2.6	4.3	9.9	8.6	6.8	0.79	0.81	11.1	10.6					
110	1.3	1.1	2.5	7.9	6.3	0.79	1.01	11.1	7.9					
	2.0	2.5	5.8	8.2	6.5	0.79	0.96	11.2	8.5					
	2.6	4.2	9.7	8.3	6.7	0.80	0.94	11.3	8.8					

- Cooling Performance is tabulated at 80.6 °F DB and 66.2 °F WB entering air. Heating performance tabulated at 68 °F EAT
- Tabulated data does not include AHRI/ISO corrections for fan and pump power.
- All capacities are expressed in MBH.
- Insulated water circuit is recommended for operation below 60 °F EWT.
- See performance correction tables for conditions beyond what is listed.
- Extrapolation is not permissible.
- Blank areas indicate conditions where operation is not recommended.

TABLE 13 - VSCS12 - EC MOTOR (ECM) - 430 CFM

EWT	GPM	WPD		COOLING						HEATING				
		PSI	FT	TC	SC	SHR	KW	HR	EER	HTG	KW	HE	LAT	COP
20	3.2	6.5	15.0							7.7	0.75	5.4	84.5	3.0
30	1.6	1.7	4.0	15.5	10.6	0.68	0.59	17.2	26.1	8.9	0.83	6.3	87.1	3.1
	2.4	3.7	8.5	15.8	11.0	0.69	0.55	17.4	28.7	9.1	0.84	6.5	87.6	3.2
	3.2	6.3	14.5	16.2	11.4	0.70	0.53	17.7	30.7	9.3	0.85	6.7	88.1	3.2
40	1.6	1.6	3.7	15.1	10.8	0.71	0.65	17.0	23.0	10.0	0.83	7.4	89.5	3.5
	2.4	3.4	7.9	15.5	11.1	0.71	0.61	17.3	25.3	10.4	0.84	7.8	90.4	3.6
	3.2	5.9	13.5	15.8	11.4	0.72	0.58	17.4	27.3	10.6	0.85	8.0	90.9	3.7
50	1.6	1.5	3.5	14.1	10.1	0.71	0.72	16.3	19.7	11.3	0.89	8.5	92.3	3.7
	2.4	3.2	7.3	14.5	10.5	0.72	0.65	16.5	22.2	11.7	0.91	8.9	93.1	3.8
	3.2	5.4	12.5	15.0	11.0	0.73	0.63	16.9	23.8	12.0	0.92	9.1	93.8	3.8
60	1.6	1.4	3.3	13.4	9.7	0.72	0.79	15.8	16.9	12.5	0.88	9.8	94.9	4.2
	2.4	3.0	6.9	13.8	10.1	0.73	0.74	16.0	18.7	13.0	0.89	10.2	95.9	4.3
	3.2	5.1	11.8	14.6	10.8	0.74	0.66	16.5	21.9	13.4	0.89	10.6	96.8	4.4
70	1.6	1.3	3.0	12.7	9.3	0.73	0.92	15.5	13.7	13.7	0.90	10.9	97.4	4.4
	2.4	2.8	6.5	13.0	9.7	0.74	0.85	15.6	15.2	14.3	0.91	11.5	98.7	4.6
	3.2	4.9	11.3	13.2	9.9	0.75	0.79	15.6	16.6	14.8	0.91	12.0	99.8	4.7
80	1.6	1.3	3.0	11.7	8.9	0.75	0.97	14.7	12.0	15.2	0.92	12.3	100.7	4.8
	2.4	2.7	6.2	12.0	9.3	0.77	0.89	14.7	13.5	15.8	0.94	12.9	102.0	4.9
	3.2	4.7	10.8	12.7	10.0	0.79	0.80	15.1	15.7	16.2	0.95	13.3	102.9	5.0
90	1.6	1.2	2.9	11.2	8.6	0.76	1.09	14.6	10.3	16.7	0.96	13.7	103.9	5.1
	2.4	2.6	6.1	11.5	8.9	0.77	1.00	14.6	11.5	17.4	0.97	14.4	105.5	5.2
	3.2	4.5	10.4	12.0	9.5	0.79	0.91	14.8	13.2	17.9	0.98	14.8	106.5	5.4
100	1.6	1.2	2.7	10.3	8.0	0.77	1.17	14.0	8.8					
	2.4	2.5	5.8	10.7	8.4	0.78	1.11	14.2	9.6					
	3.2	4.4	10.2	10.8	8.6	0.79	1.06	14.1	10.2					
110	1.6	1.1	2.5	9.7	7.6	0.78	1.28	13.8	7.6					
	2.4	2.4	5.5	10.1	7.9	0.78	1.23	14.0	8.2					
	3.2	4.3	9.9	10.3	8.2	0.79	1.18	14.0	8.7					

- Cooling Performance is tabulated at 80.6 °F DB and 66.2 °F WB entering air. Heating performance tabulated at 68 °F EAT
- Tabulated data does not include AHRI/ISO corrections for fan and pump power.
- All capacities are expressed in MBH.
- Insulated water circuit is recommended for operation below 60 °F EWT.
- See performance correction tables for conditions beyond what is listed.
- Extrapolation is not permissible.
- Blank areas indicate conditions where operation is not recommended.

Performance Data - EC Motor (ECM) (Cont'd)

TABLE 14 - VSCS15 - EC MOTOR (ECM) - 550 CFM

EWT	GPM	WPD		COOLING						HEATING				
		PSI	FT	TC	SC	SHR	KW	HR	EER	HTG	KW	HE	LAT	COP
20	4.0	7.0	16.2							8.3	0.79	5.9	82.0	3.1
30	2.0	1.9	4.5	19.1	14.2	0.74	0.56	20.7	34.3	9.2	0.85	6.6	83.5	3.2
	3.0	4.1	9.5	19.2	14.6	0.75	0.50	20.7	38.9	10.0	0.65	8.1	84.9	4.5
	4.0	7.0	16.2	19.3	14.8	0.76	0.45	20.6	42.5	10.3	0.87	7.6	85.4	3.5
40	2.0	1.9	4.3	18.6	14.5	0.77	0.62	20.4	29.9	11.4	0.88	8.7	87.3	3.8
	3.0	4.0	9.1	18.9	14.7	0.77	0.56	20.6	33.8	11.9	0.90	9.1	88.0	3.9
	4.0	6.7	15.6	18.8	14.8	0.78	0.50	20.2	37.3	12.2	0.91	9.4	88.5	3.9
50	2.0	1.8	4.1	17.4	13.2	0.75	0.69	19.4	25.2	12.8	0.91	10.0	89.6	4.1
	3.0	3.8	8.7	17.7	13.4	0.75	0.60	19.4	29.3	13.4	0.91	10.6	90.6	4.3
	4.0	6.5	14.9	17.8	13.7	0.76	0.56	19.4	32.1	13.8	0.92	10.9	91.3	4.4
60	2.0	1.6	3.6	16.4	12.6	0.76	0.75	18.7	21.9	14.6	0.92	11.7	92.5	4.6
	3.0	3.3	7.7	16.6	12.8	0.76	0.69	18.7	24.0	15.1	0.93	12.2	93.4	4.8
	4.0	5.7	13.1	16.7	12.9	0.76	0.66	18.7	25.3	15.5	0.94	12.6	94.1	4.8
70	2.0	1.4	3.3	15.5	12.2	0.78	0.85	18.1	18.3	15.9	0.93	13.0	94.7	5.0
	3.0	3.1	7.0	15.7	12.5	0.79	0.80	18.2	19.6	16.5	0.94	13.6	95.8	5.1
	4.0	5.2	12.0	15.8	12.6	0.79	0.78	18.2	20.3	17.1	0.95	14.1	96.8	5.3
80	2.0	1.4	3.2	14.7	11.9	0.80	0.94	17.7	15.7	17.6	0.97	14.6	97.7	5.3
	3.0	2.9	6.7	14.9	12.1	0.80	0.90	17.7	16.5	18.1	0.99	15.0	98.5	5.4
	4.0	5.0	11.4	15.0	12.2	0.80	0.88	17.8	17.0	18.5	1.02	15.3	99.2	5.3
90	2.0	1.3	3.0	14.0	11.6	0.82	1.05	17.3	13.4	18.7	1.02	15.5	99.5	5.4
	3.0	2.8	6.4	14.3	11.8	0.82	0.99	17.4	14.4	19.1	1.04	15.9	100.2	5.4
	4.0	4.7	10.9	14.4	12.0	0.83	0.99	17.5	14.5	19.3	1.04	16.0	100.5	5.4
100	2.0	1.2	2.8	13.2	11.0	0.83	1.17	17.0	11.3					
	3.0	2.6	6.0	13.5	11.4	0.84	1.13	17.1	12.0					
	4.0	4.4	10.2	13.6	11.5	0.84	1.11	17.1	12.3					
110	2.0	1.1	2.6	12.5	10.8	0.86	1.31	16.7	9.5					
	3.0	2.5	5.8	12.8	11.2	0.87	1.26	16.9	10.1					
	4.0	4.5	10.3	13.0	11.3	0.87	1.24	16.9	10.4					

- Cooling Performance is tabulated at 80.6 °F DB and 66.2 °F WB entering air. Heating performance tabulated at 68 °F EAT
- Tabulated data does not include AHRI/ISO corrections for fan and pump power.
- All capacities are expressed in MBH.
- Insulated water circuit is recommended for operation below 60 °F EWT.
- See performance correction tables for conditions beyond what is listed.
- Extrapolation is not permissible.
- Blank areas indicate conditions where operation is not recommended.

TABLE 15 - VSCS18 - EC MOTOR (ECM) - 685 CFM

EWT	GPM	WPD		COOLING						HEATING				
		PSI	FT	TC	SC	SHR	KW	HR	EER	HTG	KW	HE	LAT	COP
20	4.8	7.5	17.3							11.1	1.21	7.5	83.0	2.7
30	2.4	2.0	4.7	22.5	15.4	0.68	0.66	24.3	33.9	12.7	1.21	9.0	85.2	3.1
	3.6	4.3	9.9	22.6	15.5	0.68	0.63	24.3	35.7	13.2	1.21	9.5	85.9	3.2
	4.8	7.3	16.8	22.9	15.9	0.69	0.60	24.5	38.1	13.6	1.23	9.9	86.4	3.2
40	2.4	1.9	4.5	21.6	15.2	0.70	0.80	23.8	27.1	14.3	1.22	10.6	87.3	3.4
	3.6	4.1	9.5	21.8	15.6	0.71	0.75	23.9	29.2	14.6	1.22	10.9	87.8	3.5
	4.8	7.0	16.1	22.2	16.1	0.72	0.71	24.2	31.2	15.2	1.24	11.4	88.5	3.6
50	2.4	1.9	4.3	20.8	15.0	0.72	0.90	23.4	23.1	16.3	1.23	12.6	90.1	3.9
	3.6	3.9	9.1	21.8	16.0	0.73	0.83	24.2	26.2	17.0	1.24	13.3	91.0	4.0
	4.8	6.7	15.5	21.5	15.8	0.73	0.79	23.8	27.2	17.7	1.24	13.9	91.9	4.2
60	2.4	1.6	3.8	20.0	14.7	0.73	1.05	23.1	19.0	18.7	1.24	14.9	93.2	4.4
	3.6	3.5	8.0	20.7	15.2	0.73	0.98	23.6	21.1	19.5	1.25	15.7	94.3	4.6
	4.8	5.9	13.6	21.1	15.7	0.74	0.93	23.8	22.6	20.1	1.29	16.1	95.1	4.6
70	2.4	1.5	3.5	19.1	14.4	0.75	1.21	22.8	15.9	20.9	1.25	17.1	96.2	4.9
	3.6	3.2	7.3	19.4	14.8	0.76	1.13	22.8	17.1	21.8	1.27	17.9	97.5	5.0
	4.8	5.4	12.5	19.7	15.2	0.77	1.10	23.0	17.9	22.5	1.30	18.5	98.4	5.1
80	2.4	1.4	3.3	18.1	13.6	0.75	1.36	22.3	13.3	22.9	1.27	19.1	99.0	5.3
	3.6	3.0	7.0	18.5	14.3	0.77	1.28	22.4	14.4	23.9	1.29	20.0	100.3	5.4
	4.8	5.2	11.9	18.9	15.0	0.79	1.18	22.4	16.0	24.9	1.31	20.9	101.7	5.6
90	2.4	1.4	3.1	17.3	13.4	0.77	1.55	22.1	11.1	24.6	1.28	20.7	101.3	5.6
	3.6	2.9	6.6	17.7	13.9	0.78	1.46	22.3	12.1	25.5	1.31	21.5	102.5	5.7
	4.8	4.9	11.3	18.1	14.3	0.79	1.37	22.3	13.2	27.4	1.33	23.3	105.0	6.0
100	2.4	1.3	3.0	16.1	12.6	0.78	1.74	21.5	9.2					
	3.6	2.8	6.5	16.5	13.0	0.78	1.64	21.7	10.1					
	4.8	4.8	11.1	17.3	13.7	0.79	1.59	22.3	10.9					
110	2.4	1.2	2.8	15.2	11.9	0.78	1.99	21.5	7.6					
	3.6	2.7	6.2	15.7	12.5	0.79	1.88	21.6	8.4					
	4.8	4.7	10.8	16.5	13.3	0.80	1.82	22.3	9.1					

- Cooling Performance is tabulated at 80.6 °F DB and 66.2 °F WB entering air. Heating performance tabulated at 68 °F EAT
- Tabulated data does not include AHRI/ISO corrections for fan and pump power.
- All capacities are expressed in MBH.
- Insulated water circuit is recommended for operation below 60 °F EWT.
- See performance correction tables for conditions beyond what is listed.
- Extrapolation is not permissible.
- Blank areas indicate conditions where operation is not recommended.

Performance Data - EC Motor (ECM) (Cont'd)

TABLE 16 - VSCS24 - EC MOTOR (ECM) - 850 CFM

EWT	GPM	WPD		COOLING						HEATING				
		PSI	FT	TC	SC	SHR	KW	HR	EER	HTG	KW	HE	LAT	COP
20	6.2	6.6	15.2							13.6	1.56	9.0	82.8	2.6
30	3.1	1.7	4.0	29.5	19.5	0.66	1.04	32.3	28.4	15.4	1.57	10.8	84.8	2.9
	4.6	3.6	8.3	29.7	20.3	0.68	1.01	32.5	29.6	16.9	1.58	12.2	86.4	3.1
	6.2	6.3	14.4	29.9	20.7	0.69	0.97	32.5	30.9	17.2	1.59	12.5	86.8	3.2
40	3.1	1.6	3.6	29.3	20.0	0.68	1.15	32.5	25.4	18.5	1.60	13.8	88.2	3.4
	4.6	3.3	7.5	29.4	20.4	0.69	1.10	32.4	26.8	19.9	1.63	15.1	89.7	3.6
	6.2	5.6	13.0	29.5	20.7	0.70	1.04	32.3	28.5	20.4	1.65	15.5	90.2	3.6
50	3.1	1.4	3.2	28.4	19.7	0.69	1.25	32.0	22.7	21.6	1.65	16.7	91.6	3.9
	4.6	2.9	6.7	28.6	20.1	0.70	1.18	31.9	24.2	22.7	1.72	17.6	92.8	3.9
	6.2	5.0	11.6	28.7	20.5	0.71	1.12	31.9	25.7	23.5	1.74	18.3	93.6	4.0
60	3.1	1.3	3.0	27.3	19.5	0.71	1.44	31.5	19.0	24.4	1.72	19.2	94.6	4.2
	4.6	2.7	6.2	27.5	19.9	0.72	1.32	31.4	20.8	25.8	1.73	20.6	96.1	4.4
	6.2	4.7	10.8	27.8	20.4	0.73	1.21	31.3	22.9	27.1	1.77	21.8	97.5	4.5
70	3.1	1.3	2.9	26.2	19.0	0.72	1.63	31.1	16.1	27.2	1.75	21.9	97.7	4.6
	4.6	2.6	6.0	26.7	19.3	0.72	1.52	31.2	17.6	28.9	1.76	23.6	99.5	4.8
	6.2	4.5	10.4	27.1	20.1	0.74	1.42	31.3	19.1	30.5	1.80	25.0	101.2	5.0
80	3.1	1.2	2.8	24.6	18.0	0.73	1.83	30.1	13.4	29.9	1.79	24.5	100.6	4.9
	4.6	2.5	5.8	25.2	18.5	0.73	1.72	30.4	14.6	32.0	1.82	26.5	102.9	5.2
	6.2	4.3	10.0	25.8	19.2	0.74	1.66	30.8	15.6	33.3	1.87	27.6	104.3	5.2
90	3.1	1.1	2.5	23.0	16.8	0.73	2.07	29.3	11.1	33.5	1.87	27.8	104.5	5.3
	4.6	2.4	5.5	23.4	17.4	0.74	1.94	29.4	12.1	35.3	1.96	29.3	106.5	5.3
	6.2	4.2	9.7	23.9	18.2	0.76	1.81	29.4	13.2	36.5	2.00	30.4	107.8	5.3
100	3.1	1.1	2.5	21.5	16.4	0.76	2.34	28.8	9.2					
	4.6	2.3	5.3	21.9	16.7	0.76	2.20	28.7	10.0					
	6.2	4.2	9.7	22.4	17.3	0.77	2.09	28.8	10.7					
110	3.1	1.0	2.3	20.1	15.5	0.77	2.62	28.3	7.7					
	4.6	2.3	5.3	20.6	15.9	0.77	2.49	28.4	8.3					
	6.2	4.1	9.5	20.9	16.3	0.78	2.36	28.3	8.8					

- Cooling Performance is tabulated at 80.6 °F DB and 66.2 °F WB entering air. Heating performance tabulated at 68 °F EAT
- Tabulated data does not include AHRI/ISO corrections for fan and pump power.
- All capacities are expressed in MBH.
- Insulated water circuit is recommended for operation below 60 °F EWT.
- See performance correction tables for conditions beyond what is listed.
- Extrapolation is not permissible.
- Blank areas indicate conditions where operation is not recommended.

TABLE 17 - VSCS30 - EC MOTOR (ECM) - 850 CFM

EWT	GPM	WPD		COOLING						HEATING				
		PSI	FT	TC	SC	SHR	KW	HR	EER	HTG	KW	HE	LAT	COP
20	3.9	5.6	12.9							16.9	1.76	11.6	82.6	2.8
30	3.9	1.5	3.5	35.3	24.1	0.68	1.24	38.8	28.5	19.9	1.79	14.5	85.2	3.3
	5.8	3.1	7.2	35.8	24.8	0.69	1.22	39.2	29.4	20.6	1.81	15.1	85.8	3.3
	7.8	5.4	12.5	36.1	25.4	0.70	1.19	39.5	30.2	21.4	1.82	15.9	86.5	3.5
40	3.9	1.4	3.2	35.7	24.8	0.69	1.32	39.6	27.1	21.5	1.85	15.8	86.5	3.4
	5.8	2.9	6.6	36.2	25.8	0.71	1.28	39.9	28.3	22.4	1.90	16.6	87.3	3.5
	7.8	5.0	11.4	36.3	26.2	0.72	1.24	39.8	29.2	23.3	1.96	17.3	88.1	3.5
50	3.9	1.2	2.9	34.5	24.9	0.72	1.38	38.5	24.9	24.8	1.94	18.9	89.4	3.7
	5.8	2.6	6.0	34.9	25.6	0.73	1.34	38.8	25.9	26.1	2.02	19.9	90.5	3.8
	7.8	4.5	10.4	35.0	26.0	0.74	1.32	38.8	26.5	28.1	2.08	21.7	92.2	4.0
60	3.9	1.2	2.8	33.4	24.5	0.73	1.58	38.1	21.1	29.0	2.01	22.9	93.0	4.2
	5.8	2.5	5.8	33.8	25.2	0.74	1.54	38.4	21.9	30.6	2.07	24.2	94.4	4.3
	7.8	4.3	10.0	33.9	25.2	0.74	1.51	38.3	22.4	31.8	2.10	25.3	95.4	4.4
70	3.9	1.2	2.7	31.7	23.2	0.73	1.77	37.0	17.9	32.3	2.06	26.0	95.8	4.6
	5.8	2.4	5.6	32.2	23.9	0.74	1.70	37.3	18.9	34.0	2.11	27.5	97.3	4.7
	7.8	4.2	9.6	32.8	24.7	0.75	1.77	38.2	18.6	35.3	2.11	28.8	98.4	4.9
80	3.9	1.1	2.6	30.1	22.4	0.74	2.01	36.3	15.0	34.4	2.07	28.1	97.7	4.9
	5.8	2.3	5.4	30.7	23.1	0.75	1.93	36.6	15.9	35.6	2.12	29.1	98.7	4.9
	7.8	4.0	9.3	31.5	24.0	0.76	2.01	37.7	15.6	36.5	2.12	29.9	99.4	5.0
90	3.9	1.0	2.4	28.6	21.5	0.75	2.25	35.6	12.7	35.9	2.09	29.5	99.0	5.0
	5.8	2.2	5.0	29.2	22.3	0.76	2.21	36.0	13.2	36.8	2.13	30.2	99.7	5.1
	7.8	3.8	8.7	29.3	22.6	0.77	2.16	36.0	13.5	37.2	2.13	30.6	100.1	5.1
100	3.9	1.3	3.0	25.7	19.6	0.76	2.53	33.7	10.1					
	5.8	2.1	4.8	26.7	20.7	0.77	2.42	34.3	11.0					
	7.8	3.7	8.5	27.1	21.2	0.78	2.35	34.5	11.5					
110	3.9	1.2	2.8	23.6	17.1	0.72	2.89	32.7	8.2					
	5.8	2.0	4.6	25.0	17.9	0.71	2.76	33.7	9.1					
	7.8	3.6	8.3	25.1	20.0	0.79	2.69	33.6	9.4					

- Cooling Performance is tabulated at 80.6 °F DB and 66.2 °F WB entering air. Heating performance tabulated at 68 °F EAT
- Tabulated data does not include AHRI/ISO corrections for fan and pump power.
- All capacities are expressed in MBH.
- Insulated water circuit is recommended for operation below 60 °F EWT.
- See performance correction tables for conditions beyond what is listed.
- Extrapolation is not permissible.
- Blank areas indicate conditions where operation is not recommended.

Performance Data - EC Motor (ECM) (Cont'd)

TABLE 18 - VSCS36 - EC MOTOR (ECM) - 850 CFM

EWT	GPM	WPD		COOLING						HEATING				
		PSI	FT	TC	SC	SHR	KW	HR	EER	HTG	KW	HE	LAT	COP
20	9.5	9.1	21.0							19.6	2.03	13.5	82.8	2.8
30	4.8	2.6	6.0	42.9	29.8	0.69	1.52	47.2	28.3	22.3	2.12	15.9	84.9	3.1
	7.2	5.4	12.5	43.2	29.5	0.68	1.44	47.2	30.0	23.1	2.14	16.7	85.5	3.2
	9.5	8.5	19.6	43.3	29.2	0.67	1.42	47.2	30.6	23.7	2.15	17.2	85.9	3.2
40	4.8	2.5	5.8	41.7	30.6	0.73	1.65	46.5	25.2	26.1	2.14	19.6	87.8	3.6
	7.2	5.0	11.5	42.1	30.5	0.72	1.56	46.6	27.0	27.1	2.17	20.6	88.6	3.7
	9.5	8.0	18.5	42.5	29.9	0.70	1.52	46.8	28.0	28.1	2.18	21.5	89.3	3.8
50	4.8	2.3	5.3	39.8	29.6	0.74	1.75	44.9	22.7	29.8	2.19	23.2	90.6	4.0
	7.2	4.6	10.6	40.5	29.7	0.73	1.66	45.3	24.4	31.1	2.23	24.3	91.6	4.1
	9.5	7.4	17.1	41.0	29.7	0.72	1.61	45.6	25.5	31.6	2.41	24.2	91.9	3.8
60	4.8	2.1	4.8	37.8	28.2	0.74	2.02	43.8	18.7	32.7	2.46	25.2	92.8	3.9
	7.2	4.3	9.9	39.0	28.6	0.73	1.89	44.6	20.6	34.6	2.48	27.0	94.2	4.1
	9.5	6.9	15.9	39.6	29.1	0.73	1.83	45.0	21.6	36.1	2.49	28.4	95.4	4.2
70	4.8	2.0	4.6	35.5	27.1	0.76	2.28	42.4	15.6	37.1	2.50	29.4	96.1	4.3
	7.2	4.1	9.5	37.2	28.1	0.75	2.22	43.9	16.8	39.2	2.54	31.4	97.7	4.5
	9.5	6.6	15.2	38.0	28.3	0.74	2.14	44.4	17.8	40.1	2.56	32.2	98.4	4.6
80	4.8	1.8	4.2	34.0	26.7	0.78	2.64	42.1	12.9	40.1	2.61	32.0	98.4	4.5
	7.2	3.9	9.0	35.5	27.5	0.77	2.57	43.4	13.8	42.2	2.63	34.1	100.0	4.7
	9.5	6.3	14.5	36.4	27.7	0.76	2.44	43.8	14.9	43.2	2.64	35.0	100.7	4.8
90	4.8	1.7	3.9	32.4	25.8	0.79	2.98	41.7	10.9	43.1	2.66	34.9	100.7	4.7
	7.2	3.7	8.5	33.7	26.1	0.77	2.73	42.2	12.4	44.9	2.70	36.5	102.0	4.9
	9.5	6.0	13.8	34.7	26.7	0.76	2.62	42.8	13.3	45.8	2.72	37.4	102.7	4.9
100	4.8	1.6	3.7	30.0	23.9	0.79	3.15	39.9	9.5					
	7.2	3.8	8.8	31.4	24.6	0.78	2.95	40.6	10.6					
	9.5	5.8	13.4	32.3	25.3	0.78	2.84	41.1	11.4					
110	4.8	1.6	3.7	27.5	22.3	0.81	3.56	38.7	7.7					
	7.2	3.7	8.5	28.7	23.1	0.80	3.26	38.9	8.8					
	9.5	5.7	13.1	29.4	23.4	0.79	3.19	39.4	9.2					

- Cooling Performance is tabulated at 80.6 °F DB and 66.2 °F WB entering air. Heating performance tabulated at 68 F EAT
- Tabulated data does not include AHRI/ISO corrections for fan and pump power.
- All capacities are expressed in MBH.
- Insulated water circuit is recommended for operation below 60 °F EWT.
- See performance correction tables for conditions beyond what is listed.
- Extrapolation is not permissible.
- Blank areas indicate conditions where operation is not recommended.

Performance Data

TABLE 19 - ANTIFREEZE CORRECTION

		ANTIFREEZE CONCENTRATION						
		5%	10%	15%	20%	25%	30%	40%
ETHYLENE GLYCOL	TC, SC	0.998	0.995	0.993	0.991	0.989	0.987	0.984
	HTG	0.995	0.990	0.985	0.980	0.974	0.969	0.964
	WPD	1.040	1.055	1.080	1.105	1.135	1.165	1.210
PROPYLENE GLYCOL	TC, SC	0.995	0.992	0.987	0.983	0.979	0.975	0.970
	HTG	0.989	0.982	0.975	0.967	0.958	0.951	0.943
	WPD	1.035	1.055	1.100	1.145	1.200	1.260	1.320
METHANOL	TC, SC	0.999	0.995	0.990	0.986	0.982	0.980	0.978
	HTG	0.989	0.985	0.979	0.971	0.963	0.954	0.946
	WPD	1.050	1.072	1.094	1.116	1.140	1.165	1.196

TABLE 20 - AIRFLOW CORRECTION

AIRFLOW %	COOLING				HEATING		
	TC	SC	KW	HR	HTG	KW	HE
70	0.931	0.847	0.964	0.946	0.942	1.075	0.940
75	0.941	0.872	0.969	0.956	0.953	1.059	0.949
80	0.950	0.896	0.979	0.961	0.960	1.039	0.958
85	0.966	0.923	0.983	0.971	0.970	1.023	0.969
90	0.977	0.948	0.989	0.981	0.979	1.015	0.979
95	0.989	0.974	0.995	0.990	0.989	1.007	0.989
100	1.000	1.000	1.000	1.000	1.000	1.000	1.000
105	1.008	1.025	1.006	1.010	1.009	0.994	1.010
110	1.018	1.048	1.013	1.017	1.019	0.992	1.018
115	1.026	1.070	1.019	1.026	1.029	0.991	1.028

TABLE 21 - COOLING PERFORMANCE CORRECTION

EAT WB (F)	TC	EAT DB (F) - SC						HR
		70	75	80.6	85	90	95	
60	0.845	0.86	1.1	1.305	S	S	S	0.904
65	0.948	0.628	0.865	1.082	1.312	S	S	0.979
66.2	1	0.539	0.777	1	1.22	1.475	S	1
70	1.061		0.631	0.855	1.081	1.331	1.543	1.039
75	1.162			0.618	0.848	1.09	1.296	1.107

S = Sensible cooling is equal to Total Cooling

TABLE 22 - HEATING PERFORMANCE CORRECTION

EAT DB (F)	HTG	KW	HE
45	1.101	0.785	1.162
50	1.080	0.832	1.125
55	1.059	0.878	1.079
60	1.039	0.926	1.064
65	1.019	0.960	1.023
68	1.000	1.000	1.000
70	0.990	1.028	0.983
75	0.974	1.064	0.957
80	0.951	1.111	0.918

Riser Selection and Data

RISER APPLICATION AND SIZING

Technical information on heat transfer, fluid flow and pipe sizing can be found in the ASHRAE Fundamentals Handbook and various other technical documents and publications. Some of the factors affecting riser application and sizing are noise, tube erosion and economics. The Friction Loss For Risers chart (next page) displays riser tube diameter sizes as a function of flow (GPM), friction loss and water velocity. For maximum riser velocity on pressure drop per 100 ft., refer to ASHRAE 2001 Fundamentals 35.3 Table 6 for Riser Sizing. Riser sizes can be of a single diameter on low rise buildings, or varying sizes on medium to high rise buildings. Generally, riser copper type, size, length and insulation thickness are determined by the location of the unit in the building.

Risers are available in Type-M or Type-L copper, varying diameters from 3/4" to 3", and with either 1/2" or 3/4" thick closed cell foam insulation. Condensate risers are available in Type-M copper, varying diameters from 3/4" to 1 1/4", and with 3/8" thick closed cell foam insulation.

RISER EXPANSION

Generally, in medium to high rise buildings, allowance must be made for pipe expansion. Model VSCS vertical stacked water source heat pumps are furnished with hoses which act as expansion loops integral to the unit. The hose will allow for +/- 1/2" of riser expansion and contraction. Additional expansion compensation must be made in the riser system in the field where movement is expected to exceed the factory allowances. The Allowable Riser Lengths Between System Expansion Loops chart displays the expansion characteristics of risers compared to water temperature difference. Technical information on pipe expansion, contraction and anchoring can be found in the ASHRAE HVAC Systems and Equipment Handbook and various other technical documents and publications.

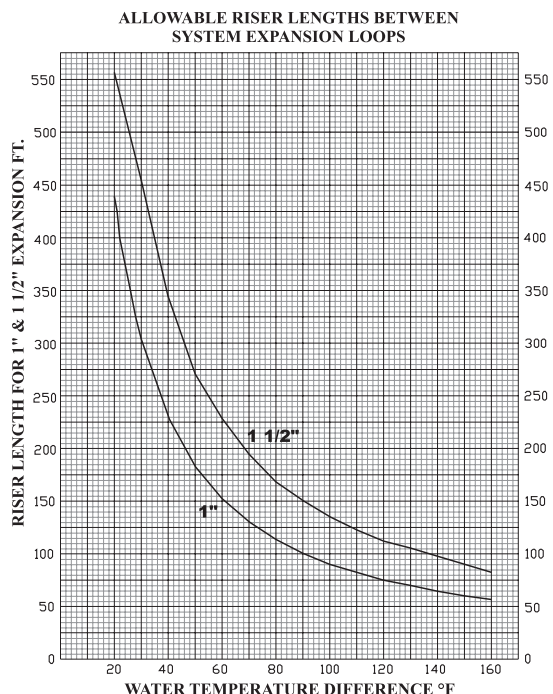
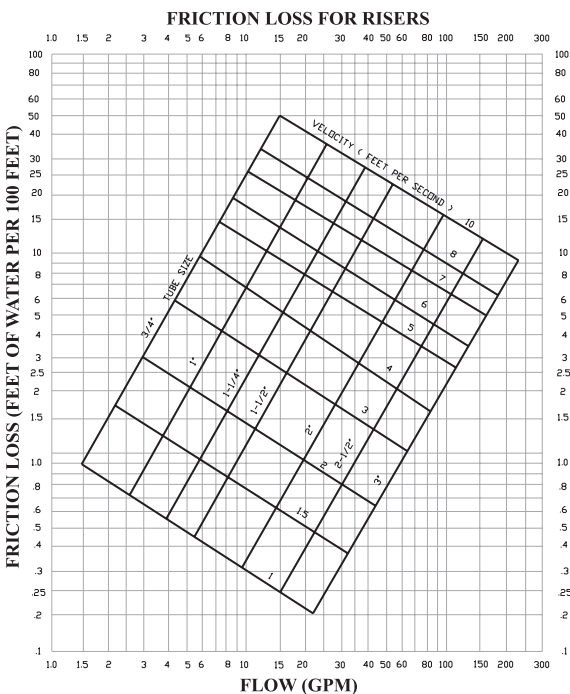

Blower Performance

TABLE 23 - PSC STANDARD BLOWER PERFORMANCE (CFM)

UNIT SIZE	RATED CFM	MIN. CFM	MOTOR SPEED	EXTERNAL STATIC PRESSURE (IN W.G.)										
				0	0.05	0.1	0.15	0.2	0.25	0.3	0.35	0.4	0.45	0.5
09	340	220	HIGH	340	330	320	310	300	285	270	255	240	225	-
			LOW	255	250	240	230	220	210	-	-	-	-	-
12	430	290	HIGH	445	435	425	415	400	385	370	355	340	320	295
			LOW	350	345	335	325	315	305	290	-	-	-	-
15	550	335	HIGH	580	570	560	550	535	520	505	485	465	445	425
			LOW	385	380	375	370	365	355	345	335	-	-	-
18	685	430	HIGH	700	690	675	660	635	615	595	575	550	525	495
			LOW	450	445	440	435	430	425	-	-	-	-	-
24	850	575	HIGH	880	855	835	815	795	770	740	710	680	650	615
			LOW	715	710	705	690	670	650	630	605	580	-	-
30	1075	700	HIGH	1115	1100	1075	1050	1020	990	960	930	895	850	800
			LOW	965	960	950	935	915	895	870	840	810	780	745
36	1220	840	HIGH	1230	1200	1170	1140	1110	1075	1040	1000	960	915	870
			LOW	1115	1100	1075	1050	1020	990	960	930	895	855	805

TABLE 24 - PSC HIGH STATIC BLOWER PERFORMANCE (CFM)

UNIT SIZE	RATED CFM	MIN. CFM	MOTOR SPEED	EXTERNAL STATIC PRESSURE (IN W.G.)																
				0	0.05	0.1	0.15	0.2	0.25	0.3	0.35	0.4	0.45	0.5	0.55	0.6	0.65	0.7	0.75	0.8
09	340	220	HIGH	375	370	360	350	340	330	315	300	285	265	245	220	-	-	-	-	-
			LOW	330	320	310	300	290	280	270	255	240	225	-	-	-	-	-	-	-
12	430	290	HIGH	485	475	465	455	440	425	410	395	380	360	340	315	-	-	-	-	-
			LOW	390	385	380	370	360	350	335	320	305	-	-	-	-	-	-	-	-
15	550	335	HIGH	665	650	635	615	595	575	555	540	520	500	475	450	420	395	370	340	-
			LOW	580	570	560	550	535	520	505	485	465	445	425	400	375	350	-	-	-
18	685	430	HIGH	750	735	715	695	675	655	630	605	580	555	525	495	465	435	-	-	-
			LOW	670	655	640	625	605	585	560	535	510	485	460	435	-	-	-	-	-
24	850	575	HIGH	990	970	950	930	910	890	865	845	820	795	770	740	710	680	650	615	575
			LOW	795	785	775	760	745	730	715	695	675	655	630	605	580	-	-	-	-
30	1075	700	HIGH	1180	1170	1160	1145	1130	1110	1090	1070	1050	1025	1000	970	940	910	875	840	800
			LOW	985	980	975	970	960	950	940	935	920	905	895	875	850	825	795	765	730
36	1220	840	HIGH	1340	1320	1295	1270	1245	1220	1190	1160	1130	1100	1070	1040	1010	980	945	910	870
			LOW	1180	1170	1160	1145	1130	1110	1090	1070	1050	1025	1000	970	940	910	875	840	800

NOTE:

1. All airflow ratings are at lowest voltage rating of dual rating (i.e., 208 volt).
2. Airflow ratings include resistance of wet coil and clean air filters.

Blower Performance (Cont'd)

TABLE 25 - ECM STANDARD BLOWER PERFORMANCE (CFM)

UNIT SIZE	RATED CFM	MIN. CFM	MOTOR SPEED	EXTERNAL STATIC PRESSURE (IN W.G.)										
				0	0.05	0.1	0.15	0.2	0.25	0.3	0.35	0.4	0.45	0.5
09	340	180	High	342	317	292	276	259	247	236	228	220	214	207
			Low	278	252	226	212	198	189	180	-	-	-	-
12	430	236	High	463	431	399	378	356	340	324	317	310	299	289
			Low	342	317	292	276	259	247	236	-	-	-	-
15	550	268	High	600	567	534	500	466	445	424	396	367	340	312
			Low	495	447	399	372	346	307	268	-	-	-	-
18	685	396	High	760	726	693	667	642	615	587	574	561	529	497
			Low	600	567	534	500	466	445	424	396	-	-	-
24	850	574	High	891	863	835	809	784	757	730	689	648	601	554
			Low	760	726	693	667	642	615	587	574	-	-	-
30	1075	718	High	1131	1105	1079	1058	1037	1016	994	972	949	934	918
			Low	918	894	870	852	835	808	781	762	743	718	-
36	1220	861	High	1265	1235	1206	1184	1163	1141	1118	1085	1051	1008	965
			Low	1065	1037	1009	987	965	949	934	910	886	874	861

TABLE 26 - ECM HIGH STATIC BLOWER PERFORMANCE (CFM)

UNIT SIZE	RATED CFM	MIN. CFM	MOTOR SPEED	EXTERNAL STATIC PRESSURE (IN W.G.)															
				0	0.05	0.1	0.15	0.2	0.25	0.3	0.35	0.4	0.45	0.5	0.55	0.6	0.65	0.7	0.75
09	340	220	High	411	382	354	334	315	300	286	279	272	263	254	242	231	220	-	-
			Low	342	317	292	276	259	247	236	228	220	-	-	-	-	-	-	-
12	430	290	High	554	529	504	477	451	430	408	393	378	360	341	330	319	300	-	-
			Low	463	431	399	378	356	340	324	317	310	299	290	-	-	-	-	-
15	550	335	High	659	623	587	564	541	511	482	462	441	419	397	372	346	320	-	-
			Low	600	567	534	500	466	445	424	396	367	340	312	-	-	-	-	-
18	685	430	High	891	863	835	809	784	757	730	689	648	601	554	518	482	446	408	-
			Low	760	726	693	667	642	615	587	574	561	529	497	469	441	412	-	-
24	850	575	High	1002	971	940	912	883	854	826	800	774	749	724	698	671	643	615	586
			Low	866	827	789	762	735	708	682	659	636	612	587	571	-	-	-	-
30	1075	700	High	1265	1235	1206	1184	1163	1141	1118	1085	1051	1008	965	913	861	808	756	701
			Low	1065	1037	1009	987	965	949	934	910	886	874	861	839	818	-	-	-
36	1220	840	High	1462	1418	1375	1331	1287	1241	1194	1153	1112	1053	994	964	934	903	872	840
			Low	1265	1235	1206	1184	1163	1141	1118	1085	1051	1008	965	913	861	-	-	-

Electrical Data

TABLE 27 - PSC - STANDARD BLOWER - 208/230 VOLT

UNIT SIZE	SUPPLY VOLTAGE	COMPRESSOR				BLOWER		MIN. CCT. AMPACITY	MAX FUSE / CCT. BKR. AMP
		QTY		RLA	LRA	HP	FLA		
09	208-230/1/60	1	@	3.7	22.0	0.10	0.8	5.43	15
12	208-230/1/60	1	@	4.7	25.0	0.10	0.8	6.68	15
15	208-230/1/60	1	@	5.6	29.0	0.17	1.2	8.20	15
18	208-230/1/60	1	@	9.0	48.0	0.17	1.2	12.45	20
24	208-230/1/60	1	@	12.8	58.3	0.25	1.5	17.50	30
30	208-230/1/60	1	@	14.1	73.0	0.33	2.6	20.23	30
36	208-230/1/60	1	@	16.7	79.0	0.50	3.2	24.08	40

TABLE 28 - PSC - HI STATIC BLOWER - 208/230 VOLT

UNIT SIZE	SUPPLY VOLTAGE	COMPRESSOR				BLOWER		MIN. CCT. AMPACITY	MAX FUSE / CCT. BKR. AMP
		QTY		RLA	LRA	HP	FLA		
09	208-230/1/60	1	@	3.7	22.0	0.10	0.8	5.43	15
12	208-230/1/60	1	@	4.7	25.0	0.17	1.2	7.08	15
15	208-230/1/60	1	@	5.6	29.0	0.17	1.2	8.20	15
18	208-230/1/60	1	@	9.0	48.0	0.25	1.5	12.75	20
24	208-230/1/60	1	@	12.8	58.3	0.33	2.6	18.60	30
30	208-230/1/60	1	@	14.1	73.0	0.33	2.6	20.23	30
36	208-230/1/60	1	@	16.7	79.0	0.50	3.2	24.08	40

TABLE 29 - PSC - STANDARD BLOWER - 265 VOLT

UNIT SIZE	SUPPLY	COMPRESSOR				BLOWER		MIN. CCT. AMPACITY	MAX FUSE / CCT. BKR. AMP
	VOLTAGE	QTY		RLA	LRA	HP	FLA		
09	265/1/60	1	@	3.4	23.0	0.10	0.7	4.95	15
12	265/1/60	1	@	4.8	26.3	0.10	0.7	6.70	15
15	265/1/60	1	@	5.0	28.0	0.17	0.8	7.05	15
18	265/1/60	1	@	7.1	43.0	0.17	0.8	9.68	15
24	265/1/60	1	@	9.6	54.0	0.25	1.3	13.30	20
30	265/1/60	1	@	11.2	60.0	0.33	1.9	15.90	25
36	265/1/60	1	@	13.5	72.0	0.50	2.2	19.08	30

TABLE 30 - PSC - HI STATIC BLOWER - 265 VOLT

UNIT SIZE	SUPPLY VOLTAGE	COMPRESSOR				BLOWER		MIN. CCT. AMPACITY	MAX FUSE / CCT. BKR. AMP
		QTY		RLA	LRA	HP	FLA		
09	265/1/60	1	@	3.4	23.0	0.10	0.7	4.95	15
12	265/1/60	1	@	4.8	26.3	0.17	0.8	6.80	15
15	265/1/60	1	@	5.0	28.0	0.25	1.3	7.55	15
18	265/1/60	1	@	7.1	43.0	0.25	1.3	10.18	15
24	265/1/60	1	@	9.6	54.0	0.33	1.9	13.90	20
30	265/1/60	1	@	11.2	60.0	0.33	1.9	15.90	25
36	265/1/60	1	@	13.5	72.0	0.50	2.2	19.08	30

Electrical Data (Cont'd)

TABLE 31 - ECM - STANDARD BLOWER - 208/230 VOLT

UNIT SIZE	SUPPLY VOLTAGE	COMPRESSOR				BLOWER		MIN. CCT. AMPACITY	MAX FUSE / CCT. BKR. AMP
		QTY		RLA	LRA	HP	FLA		
09	208-230/1/60	1	@	3.7	22.0	0.33	1.0	5.63	15
12	208-230/1/60	1	@	4.7	25.0	0.33	1.0	6.88	15
15	208-230/1/60	1	@	5.6	29.0	0.33	2.0	9.00	15
18	208-230/1/60	1	@	9.0	48.0	0.33	2.0	13.25	20
24	208-230/1/60	1	@	12.8	58.3	0.33	2.0	18.00	30
30	208-230/1/60	1	@	14.1	73.0	0.50	2.4	20.03	30
36	208-230/1/60	1	@	16.7	79.0	0.50	2.4	23.28	35

TABLE 32 - ECM - OPTIONAL HI-STATIC BLOWER - 208/230 VOLT

UNIT SIZE	SUPPLY VOLTAGE	COMPRESSOR				BLOWER		MIN. CCT. AMPACITY	MAX FUSE / CCT. BKR. AMP
		QTY		RLA	LRA	HP	FLA		
09	208-230/1/60	1	@	3.7	22.0	0.33	1.0	5.63	15
12	208-230/1/60	1	@	4.7	25.0	0.33	1.0	6.88	15
15	208-230/1/60	1	@	5.6	29.0	0.33	2.0	9.00	15
18	208-230/1/60	1	@	9.0	48.0	0.33	2.0	13.25	20
24	208-230/1/60	1	@	12.8	58.3	0.33	2.0	18.00	30
30	208-230/1/60	1	@	14.1	73.0	0.50	2.4	20.03	30
36	208-230/1/60	1	@	16.7	79.0	0.50	2.4	23.28	35

TABLE 33 - ECM - STANDARD BLOWER - 265 VOLT

UNIT SIZE	SUPPLY VOLTAGE	COMPRESSOR				BLOWER		MIN. CCT. AMPACITY	MAX FUSE / CCT. BKR. AMP
		QTY		RLA	LRA	HP	FLA		
09	265/1/60	1	@	3.4	23.0	0.33	1.0	5.25	15
12	265/1/60	1	@	4.8	26.3	0.33	1.0	7.00	15
15	265/1/60	1	@	5.0	28.0	0.33	2.0	8.25	15
18	265/1/60	1	@	7.1	43.0	0.33	2.0	10.88	15
24	265/1/60	1	@	9.6	54.0	0.33	2.0	14.00	20
30	265/1/60	1	@	11.2	60.0	0.50	2.4	16.40	25
36	265/1/60	1	@	13.5	72.0	0.50	2.4	19.28	30

TABLE 34 - ECM - OPTIONAL HI-STATIC BLOWER - 265 VOLT

UNIT SIZE	SUPPLY VOLTAGE	COMPRESSOR				BLOWER		MIN. CCT. AMPACITY	MAX FUSE / CCT. BKR. AMP
		QTY		RLA	LRA	HP	FLA		
09	265/1/60	1	@	3.4	23.0	0.33	1.0	5.25	15
12	265/1/60	1	@	4.8	26.3	0.33	1.0	7.00	15
15	265/1/60	1	@	5.0	28.0	0.33	2.0	8.25	15
18	265/1/60	1	@	7.1	43.0	0.33	2.0	10.88	15
24	265/1/60	1	@	9.6	54.0	0.33	2.0	14.00	20
30	265/1/60	1	@	11.2	60.0	0.50	2.4	16.40	25
36	265/1/60	1	@	13.5	72.0	0.50	2.4	19.28	30

Dimensional Data

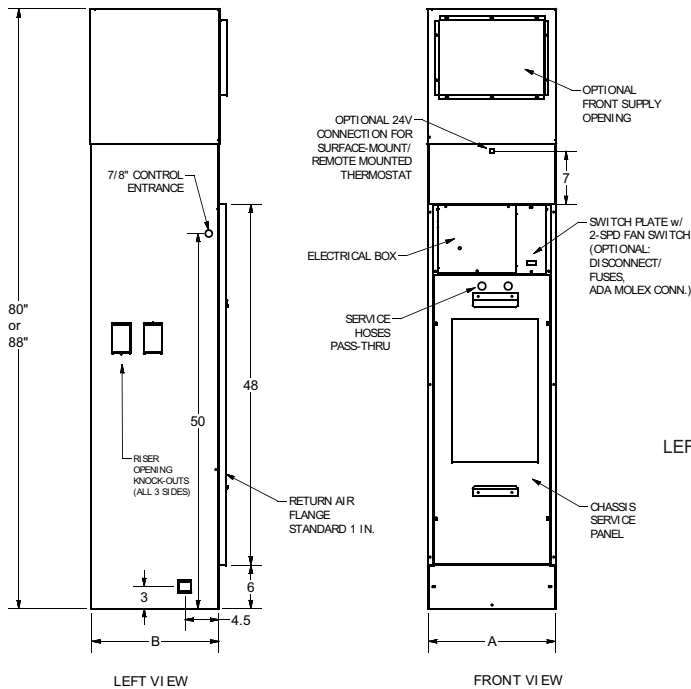

Cabinet Dimensions			
Model	A	B	R.A Flange Width
09-12	17	17	16
15-24	20	20	19
30-36	24	24	23

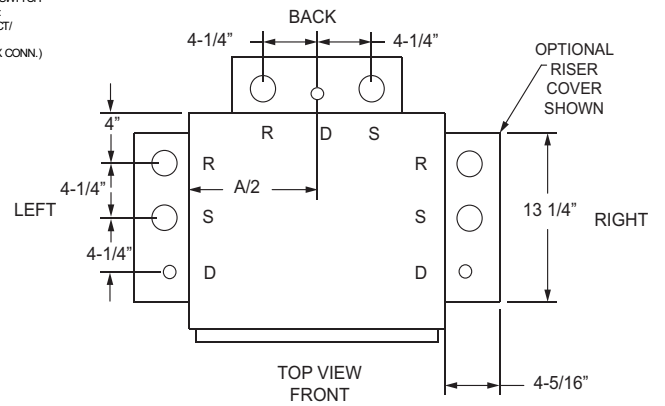

R - RETURN RISER
S - SUPPLY RISER
D - DRAIN RISER

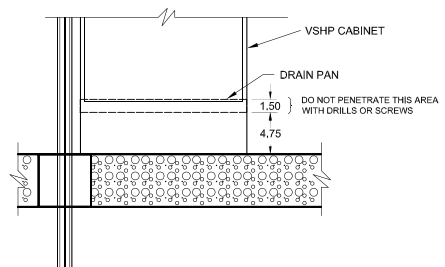
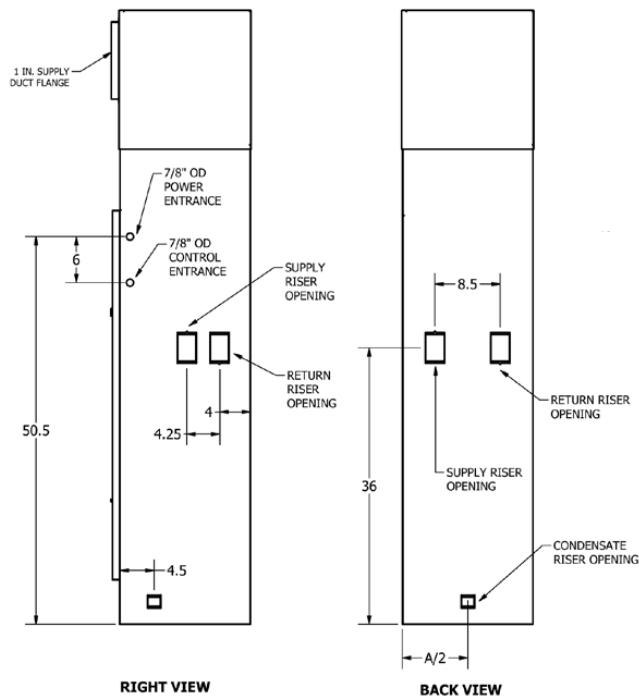

- Note:
- 1) Supply, Return, and Condensate riser openings are pre-punched on all sides and field convertible. Cut tabs to remove knock-out.
 - 2) Supply and Return openings are 4" x 2.5". During riser installation, ensure stub-out is centered in supply and return openings.
 - 3) Condensate P-trap is accessible from front by removing bottom cover plate.
 - 4) Riser and shut-off location is measured from base of cabinet and does not include stand height.

LD19318

Dimensional Data (Cont'd)

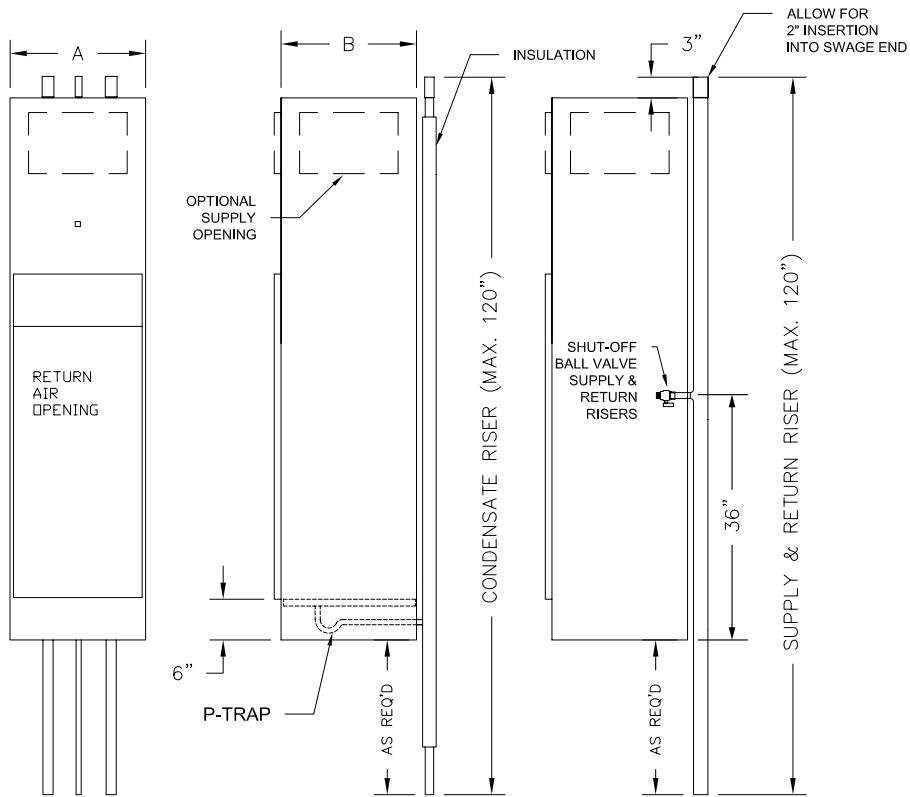

FRONT VIEW
(BACK RISERS)

RIGHT SIDE VIEW
CONDENSATE RISER

STANDARD
RISER

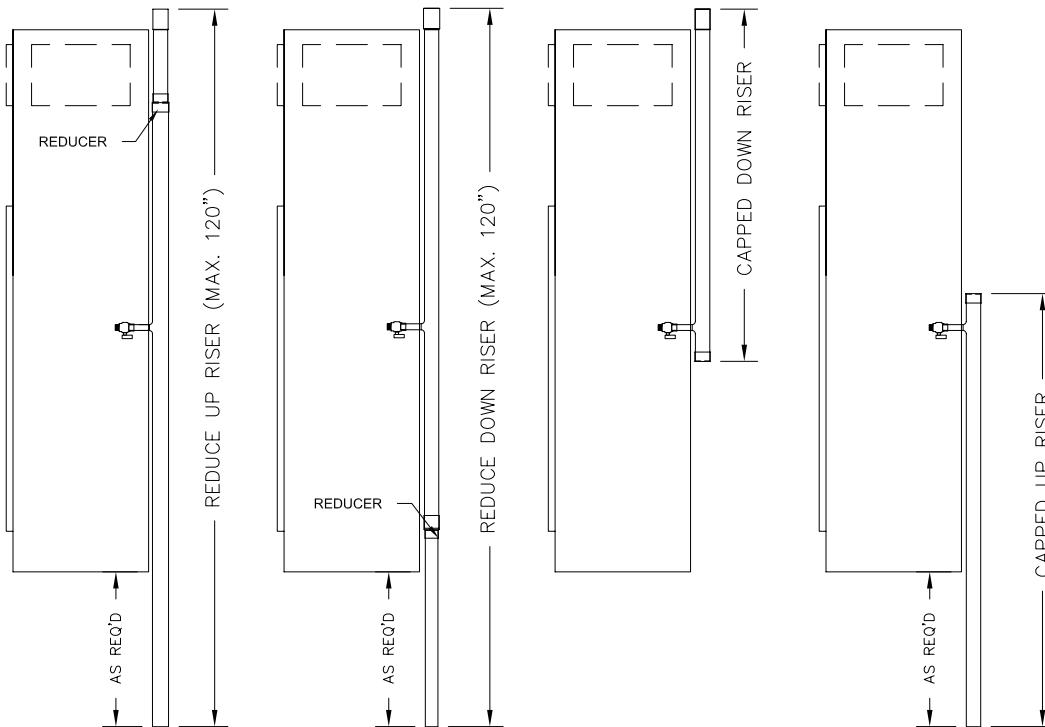

REDUCE UP
RISER

REDUCE DOWN
RISER

CAPPED DOWN
RISER

CAPPED UP
RISER

Note:
13. Riser shut-off valve is measured from base of cabinet and does not include stand height.

LD19330

CABINET DIMENSIONS			
MODEL	A	B	C
9-12	17	8	12
15-24	20	12	14
30-36	24	16	18

1. Optional Fresh Air option comes with 4-1/4" R.A flange.
2. Optional front supply opening comes with 4-1/4" duct flange.
3. All other openings come with standard 1" duct flange.
4. Left and Right hand versions shown.

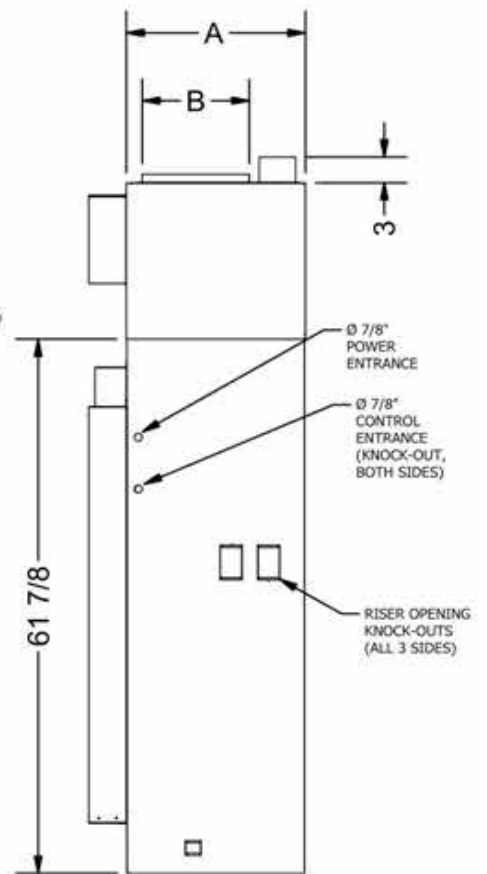
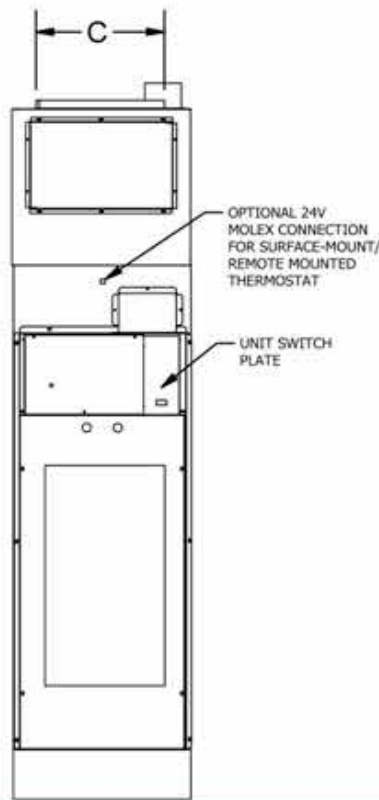
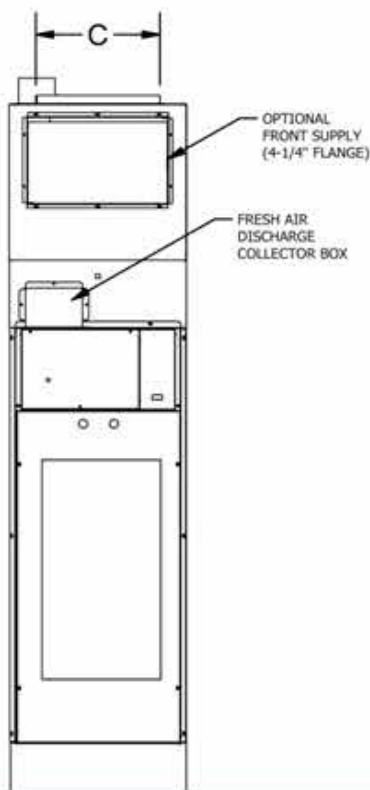
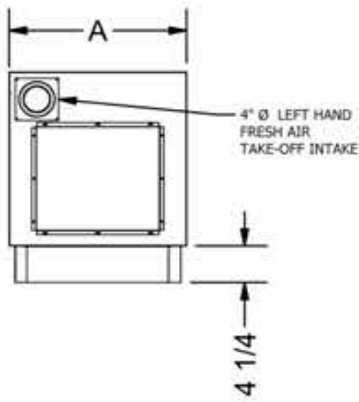
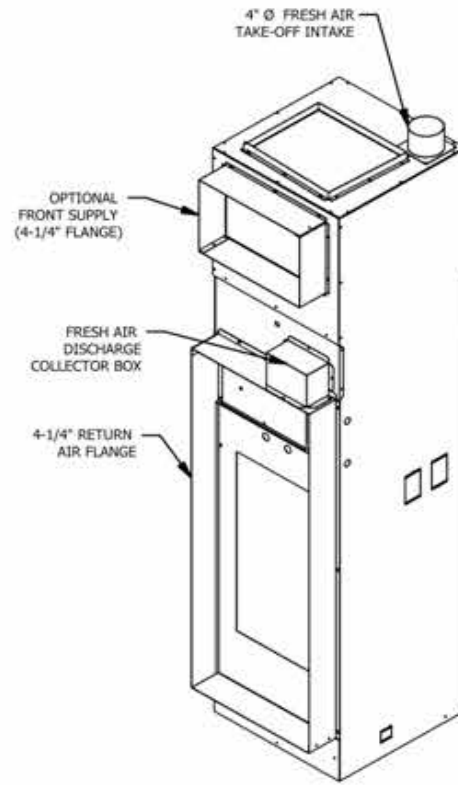

Dimensional Data (Cont'd)

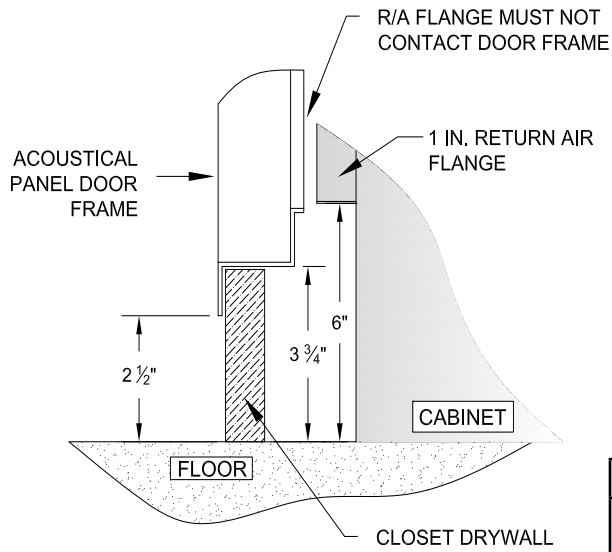

* Cut away view for standard cabinet with no stand. Add stand height to cabinet to obtain correct dimension of R/A panel from floor.

Note:
1) Dimensions shown do not include optional stand height.

ALL DIMENSIONS ARE IN INCHES						
MODEL	A	B	C	D	ROUGH-IN WIDTH	ROUGH-IN HEIGHT
VSCS09/12	22.75	20.50	16.25	18.50	20.75	52.75
VSCS15/18/24	25.75	23.50	19.25	21.50	23.75	52.75
VSCS30/36	29.75	27.50	23.25	25.50	27.75	52.75

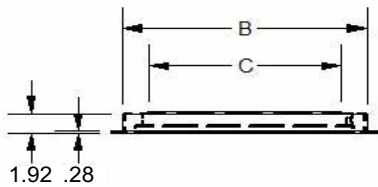

NOTES:

- Acoustic Panel powder coated in 'Appliance White'
- Acoustic Panel may be installed on the right-hand side or left-hand side

IMPORTANT: For maximum R.A. flow, flush-mounted acoustic panel must be centered vertically and horizontally over the Return Air opening of the cabinet. Supply air duct collar extensions may be required to prevent short cycling.

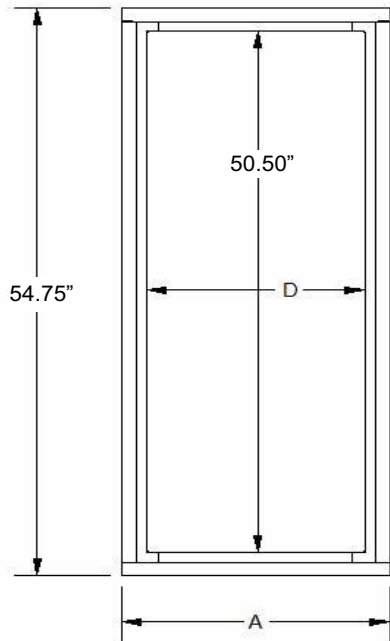

Mounting Holes x 6

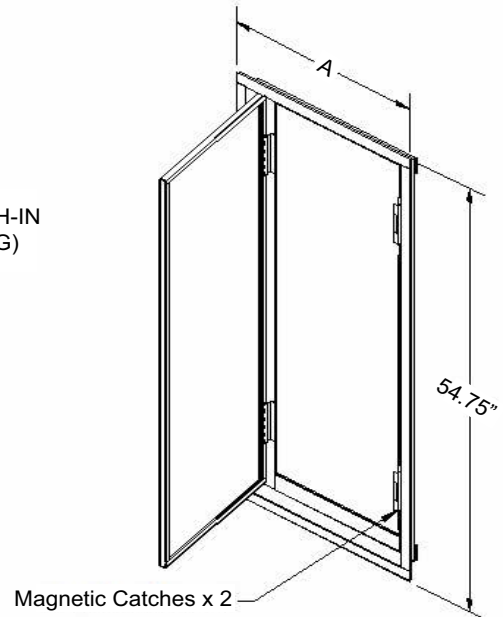
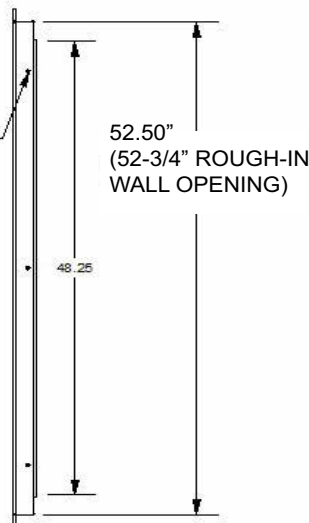

LD19319

Note:
1) See figure on Page 35 for additional R.A. panel and cabinet installation information.

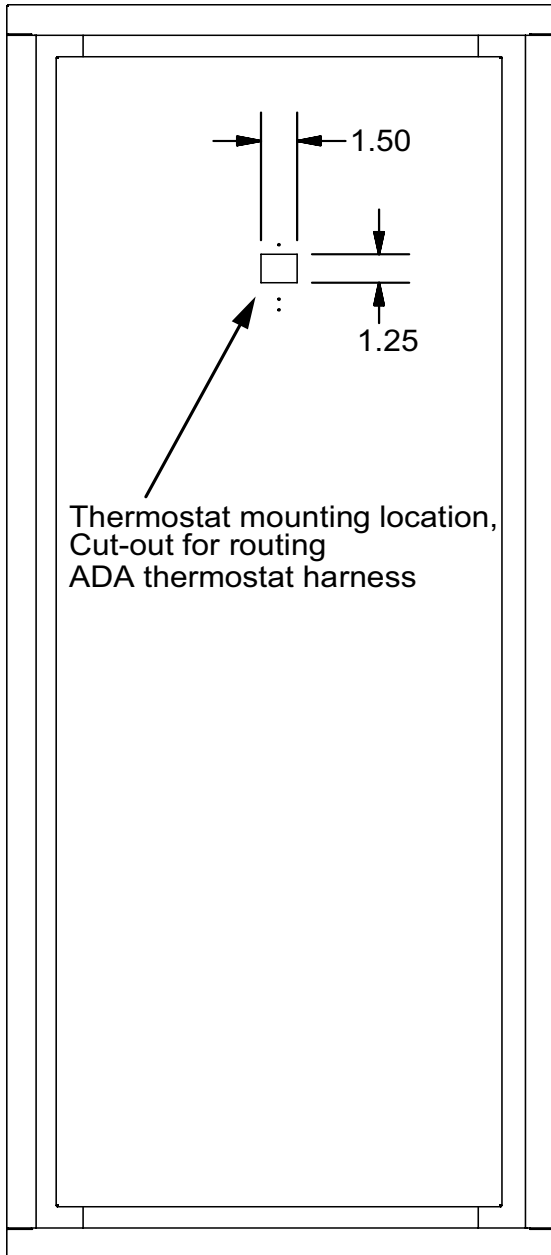

LEFT HAND OPENING SHOWN

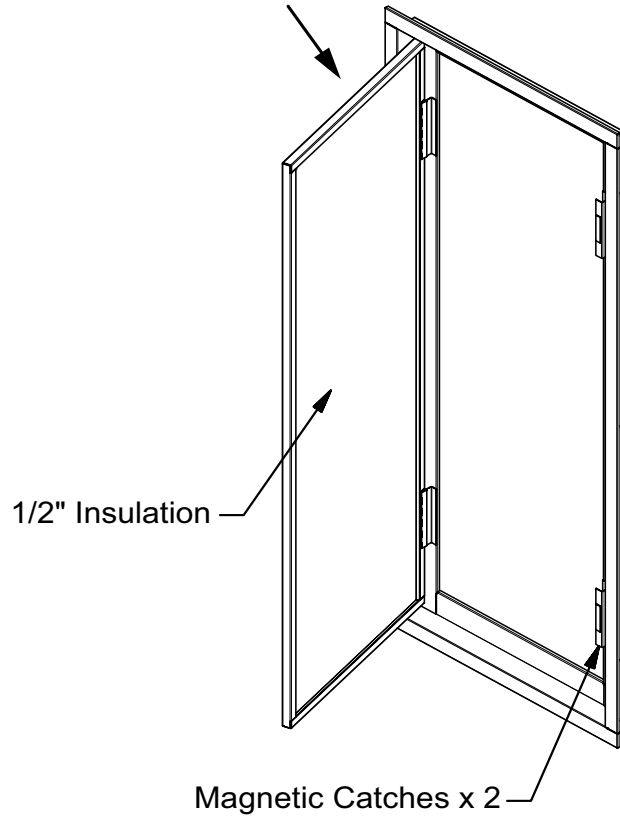

Notes:

- Powder coated in 'Appliance White'
- Inside panel lined with 1/2" acoustical insulation
- Hinged panel complete with magnetic latches
- Panel comes either Left or Right hand opening

LD19320

Dimensional Data (Cont'd)

RETURN AIR PANEL

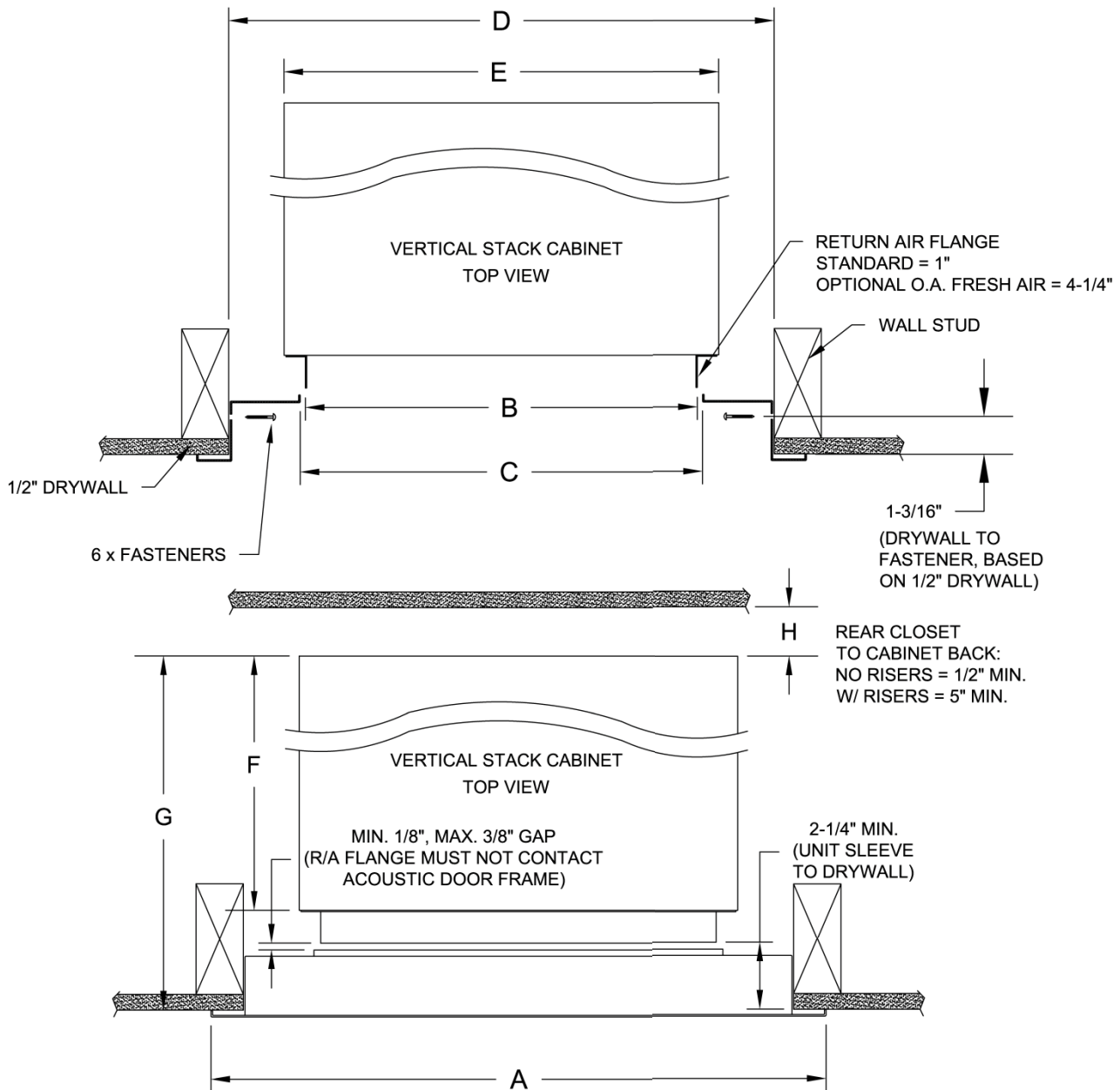

UNIT SIZE	A (PANEL WIDTH)	B (SLEEVE WIDTH)	C (R/A PANEL OPENING)	D (ROUGH IN WIDTH)	E (UNIT WIDTH)	F (UNIT DEPTH)	G (NO OA OPTION)	G (OA OPTION)
09 / 12	22 3/4	16	16 1/4	20 3/4 ± 1/8	17	17	20 1/4 MIN. 20 1/2 MAX	24 1/4 MIN. 24 1/2 MAX
15 / 18 / 24	25 3/4	19	19 1/4	23 3/4 ± 1/8	20	20	23 1/4 MIN 23 1/2 MAX	27 1/4 MIN 27 1/2 MAX
30 / 36	29 3/4	23	23 1/4	27 3/4 ± 1/8	24	24	27 1/4 MIN 27 1/2 MAX	31 1/4 MIN 31 1/2 MAX

All dimensions are in inches.

SUPPLY GRILLES

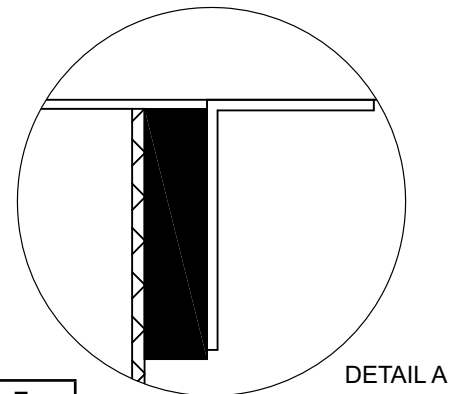
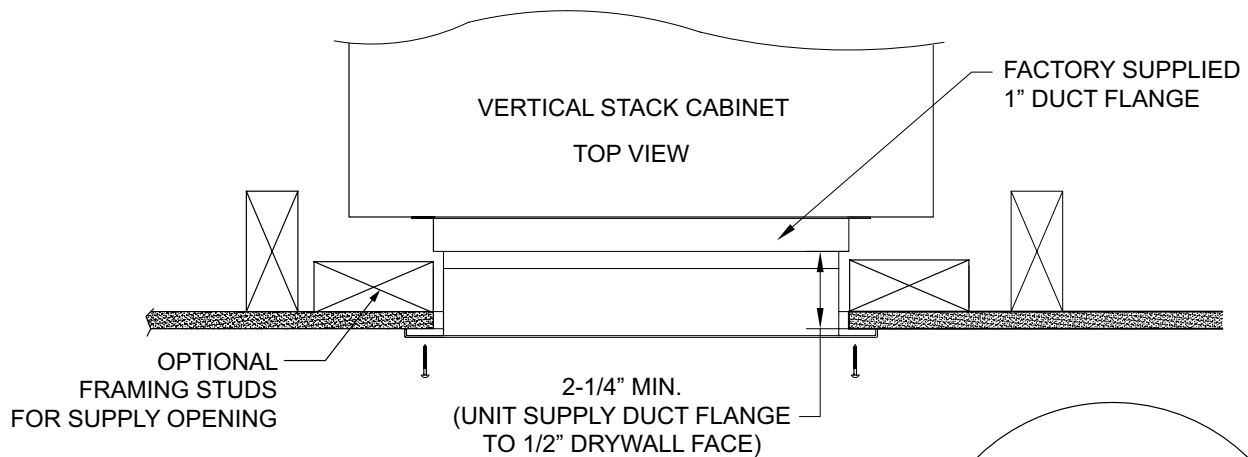
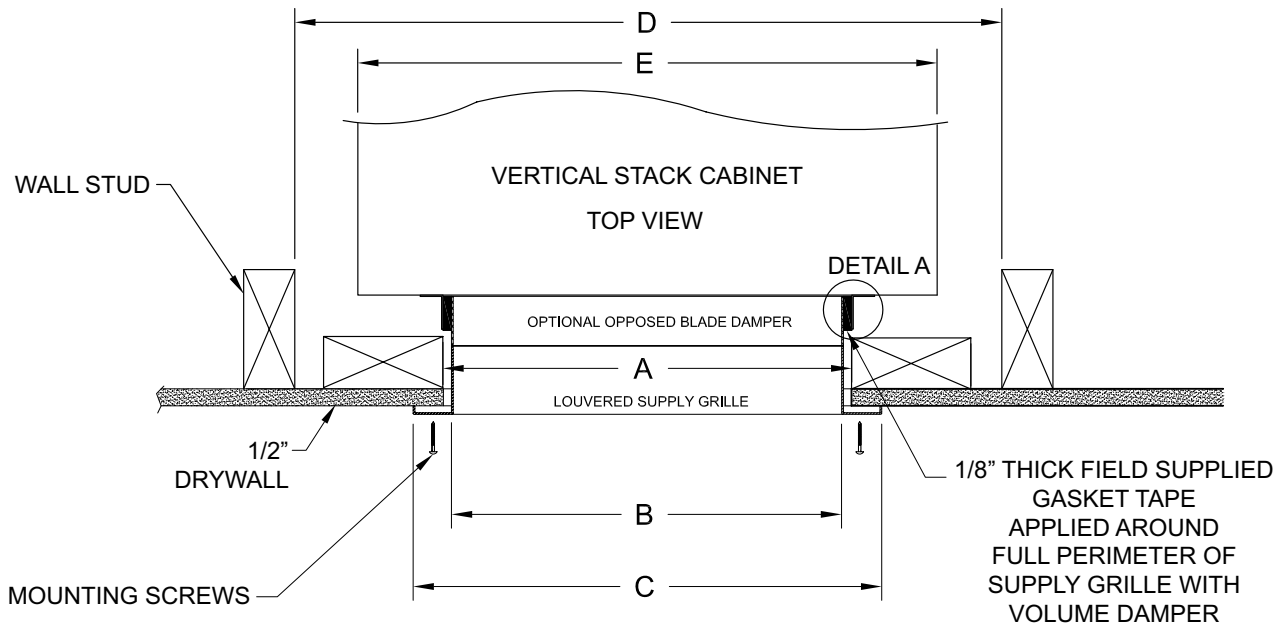

UNIT SIZE	A (SUPPLY GRILLE NOMINAL WIDTH)	B (GRILLE WIDTH)	C (GRILLE FLANGE WIDTH)	D (ROUGH IN WIDTH)	E (UNIT WIDTH)
09 / 12	X	B=X-0.5"	C=X+1.75"	20 3/4 ± 1/8	17
15 / 18 / 24	X	B=X-0.5"	C=X+1.75"	23 3/4 ± 1/8	20
30 / 36	X	B=X-0.5"	C=X+1.75"	27 3/4 ± 1/8	24

All dimensions are in inches and typical for JCI-supplied grilles only. Check dimensions for field-supplied grilles, as dimensions can be different.

LD19321

Dimensional Data (Cont'd)

TABLE 35 - UNIT SUPPLY OPENING SIZES

MODEL	HORIZONTAL OPENINGS					TOP OPENING
	SINGLE HORIZONTAL		DOUBLE HORIZONTAL		TRIPLE HORIZONTAL	
	NO TOP OPENING	W/ TOP OPENING	NO TOP OPENING	W/ TOP OPENING	NO TOP OPENING	
9	14W x 12H	14W x 6H	14W x 8H	Not Available	Not Available	12 x 8
12	14W x 14H	14W x 6H	14W x 10H	Not Available	Not Available	12 x 8
15	16W x 14H	14W x 6H	14W x 10H	Not Available	14W x 8H	14 x 12
18	Not Available	14W x 6H	14W x 12H	14W x 6H	14W x 10H	14 x 12
24	Not Available	14W x 10H	16W x 14H	14W x 6H	14W x 10H	14 x 12
30	Not Available	14W x 6H	20W x 14H	14W x 6H	16W x 12H	18 x 16
36	Not Available	14W x 10H	Not Available	14W x 6H	16W x 14H	18 x 16

- Unit mounted supply grilles will be supplied as double-deflection type.
- Grilles for unequal airflow applications (e.g., unit-mounted plus ducted supply) shall be provided with integral opposed-blade dampers.
- All grilles will be supplied in standard "Appliance White" painted finish.
- Grilles are shipped loose for field installation upon completion of cabinet / ductwork / drywall installation.
- Top opening size does not change. When combined with any other discharge arrangement, shall be included in determining horizontal opening grille size.
- Openings marked "Not Available" result in face velocities outside the recommended 300-500 FPM range.
- Hi-Static Blower option is not recommended or single horizontal discharge openings with unit mounted supply grille.

TABLE 36 - UNIT SUPPLY FACE VELOCITY (FPM)

MODEL	HORIZONTAL OPENINGS					TOP OPENING
	SINGLE HORIZONTAL		DOUBLE HORIZONTAL		TRIPLE HORIZONTAL	
	NO TOP OPENING	W/ TOP OPENING	NO TOP OPENING	W/ TOP OPENING	NO TOP OPENING	
9	291	272	219	Not Available	Not Available	510
12	316	344	221	Not Available	Not Available	645
15	354	314	283	Not Available	236	471
18	Not Available	391	294	294	235	587
24	Not Available	397	273	364	291	729
30	Not Available	416	276	339	269	538
36	Not Available	410	Not Available	385	261	610

- Tabulated Face velocities do not account for supply grille free area factor. Face velocities at supply grille will be higher depending on grille type.
- Face velocities are based on the nominal rated CFM and in feet per minute (FPM).
- Face velocities are calculated by taking the average across all openings. Tabulated top opening face velocity is only for units with single Top Opening and no horizontal openings.

Hose Kits - NPSH Water Connection

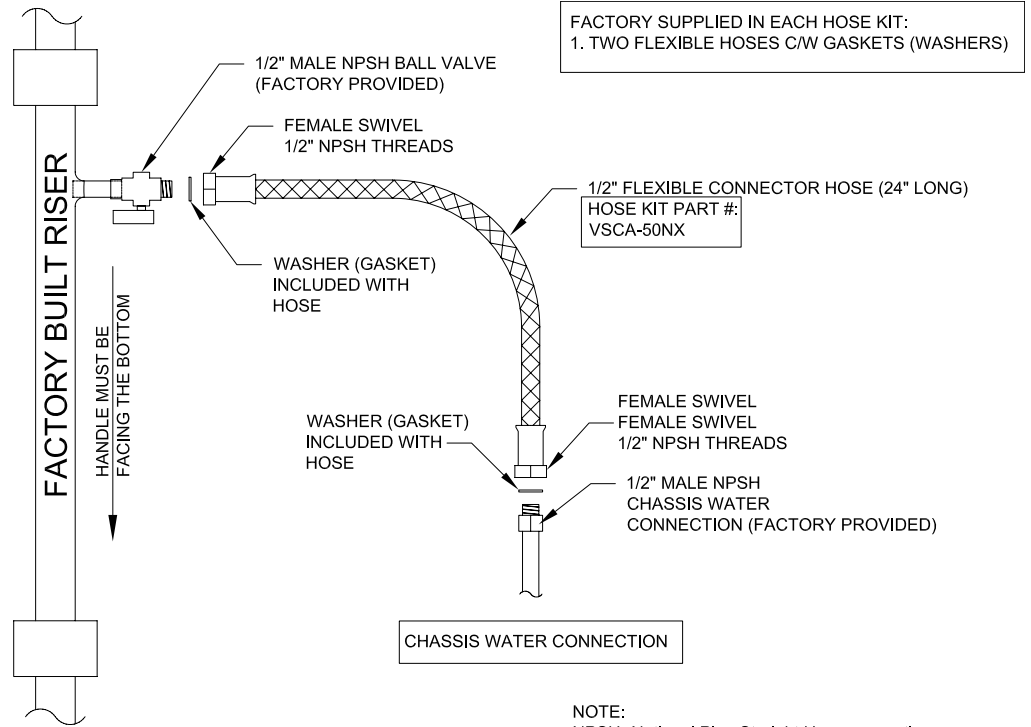

LD18126

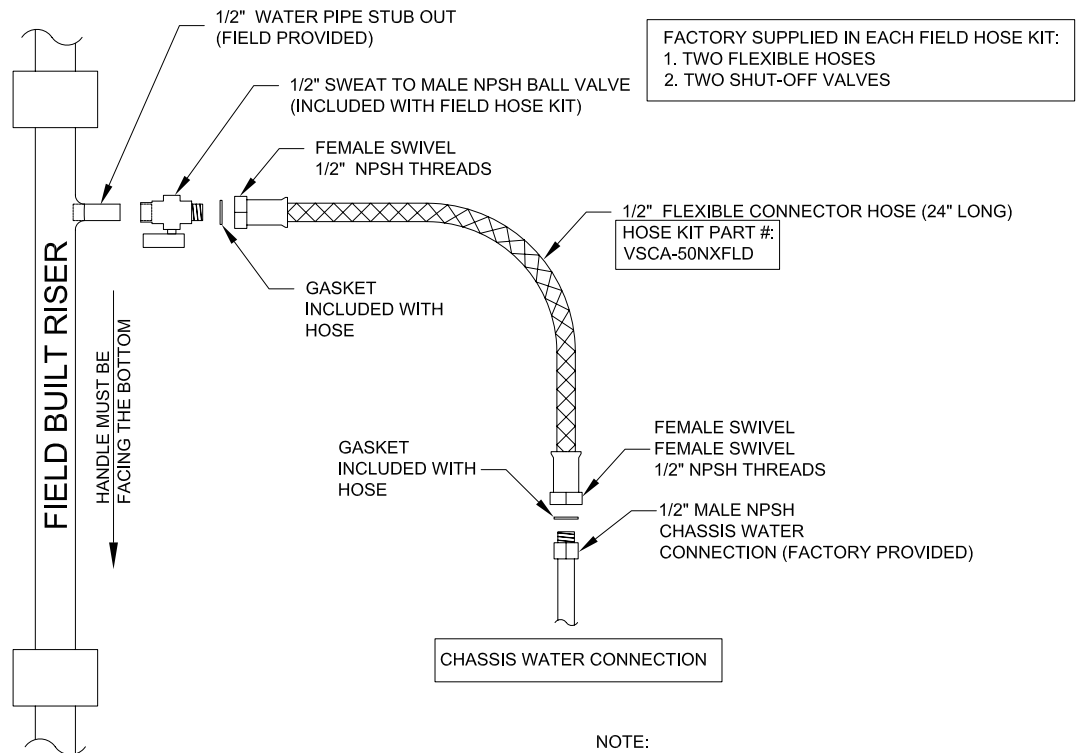

LD18127

Hose Kits - JIC Water Connection

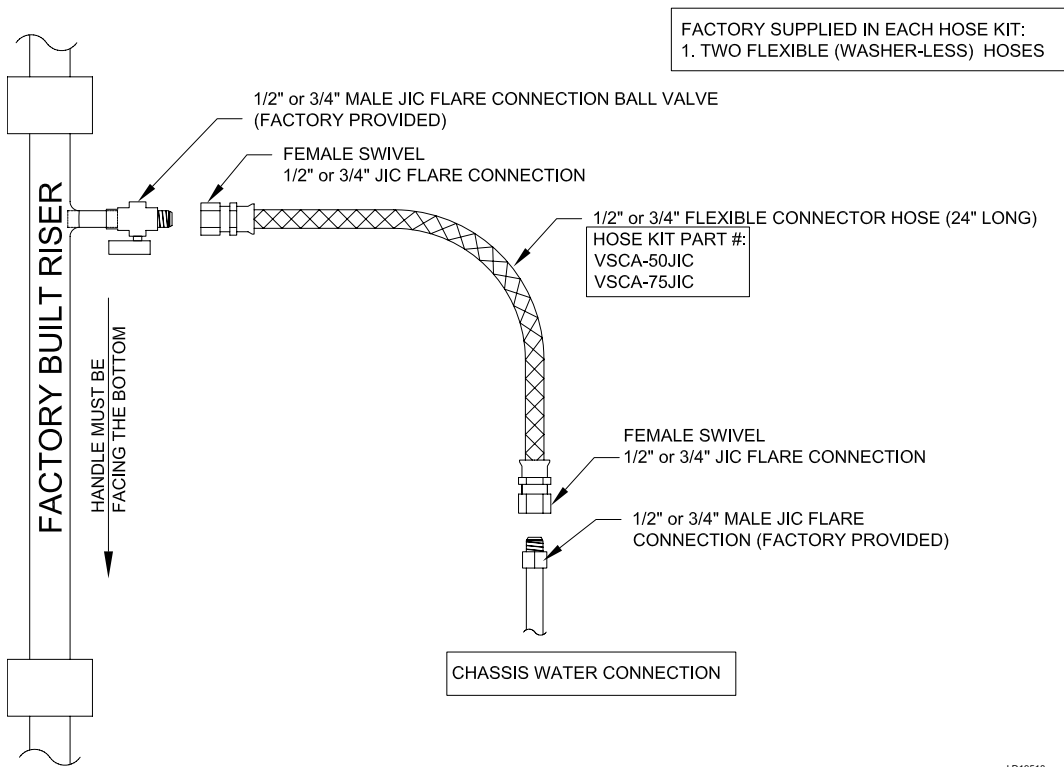

LD19518

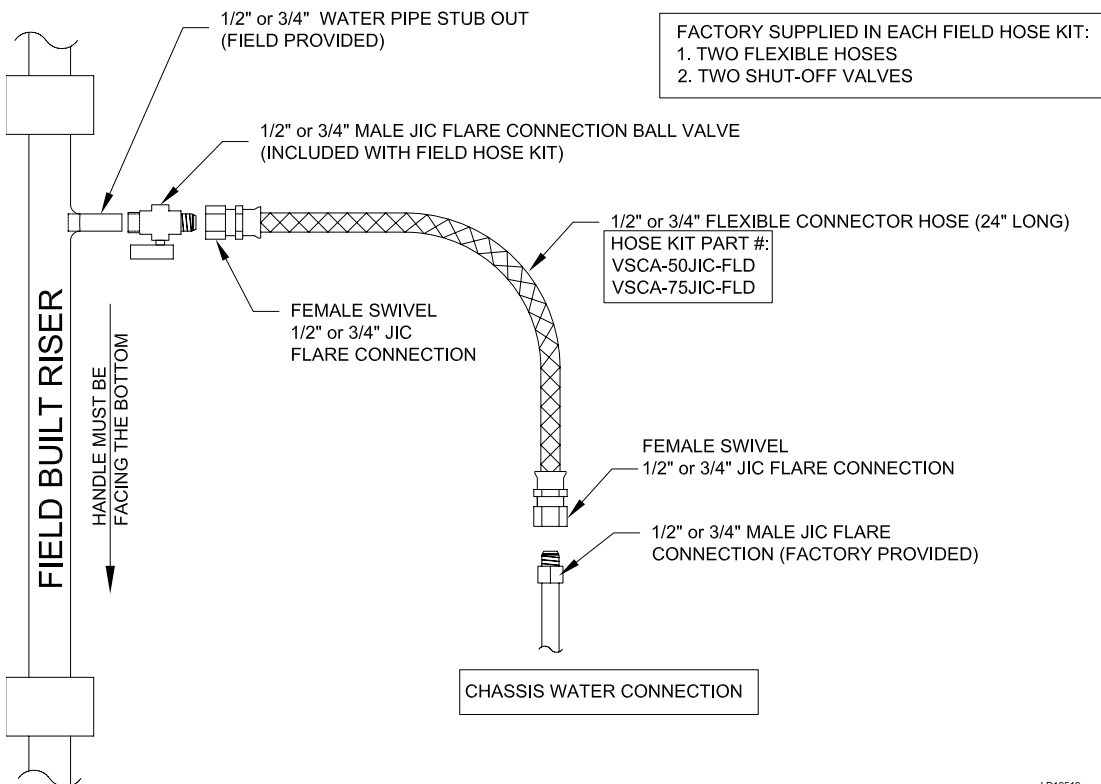

LD19519

Discharge Configurations

RIGHT HAND RISER

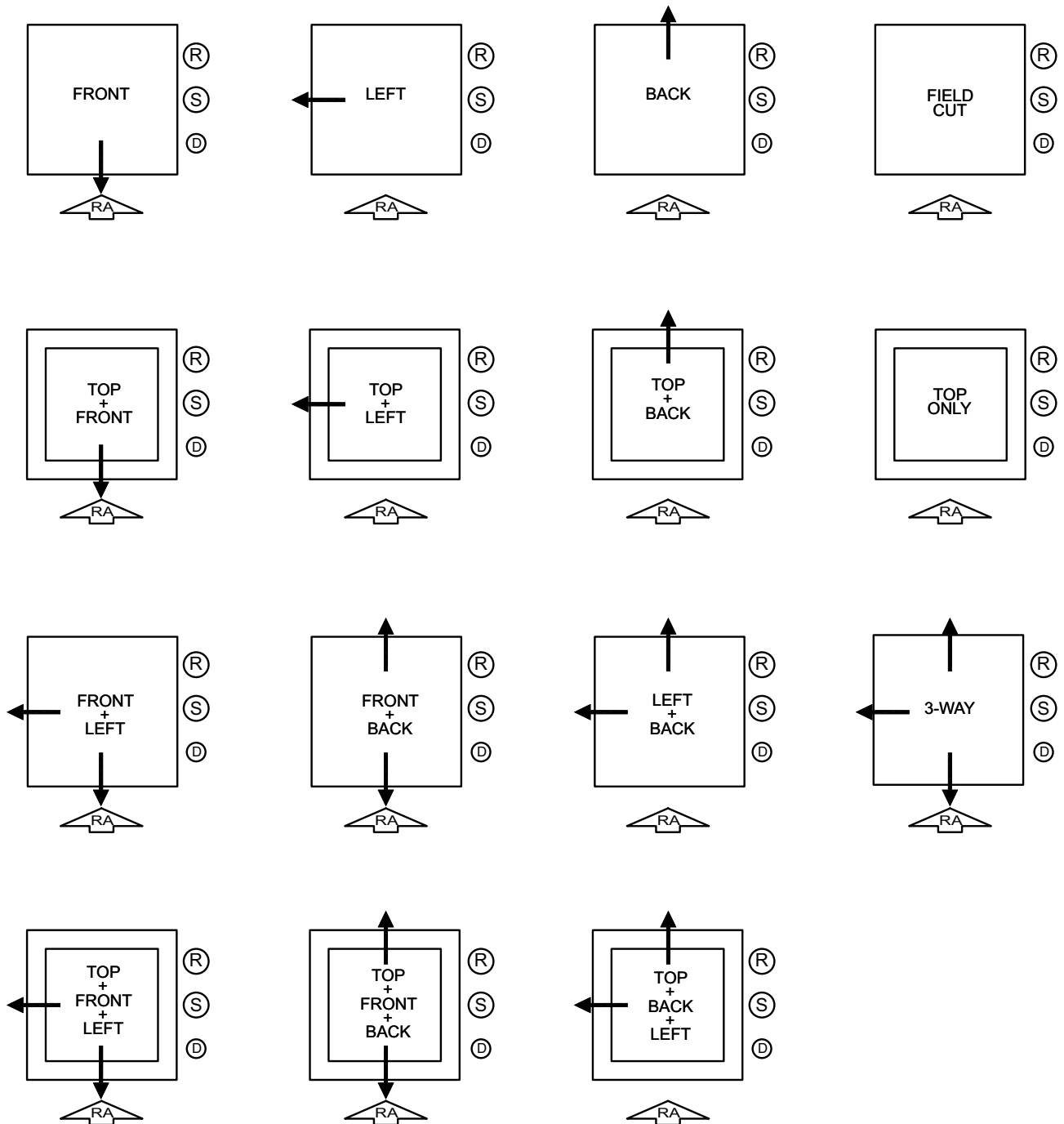

NOTES:

- 1) RETURN AIR OPENING SIDE IS DEFINED AS FRONT OF UNIT (CHASSIS AND CONTROL SERVICE ACCESS).
- 2) 3-WAY DISCHARGE ARRANGEMENT IS NOT RECOMMENDED FOR UNIT SIZES 009, 012
- 3) SINGLE DISCHARGE OPENING (EXCEPT TOP DISCHARGE) IS NOT RECOMMENDED FOR UNIT SIZES 030, 036

Discharge Configurations (Cont'd)

LEFT HAND RISER

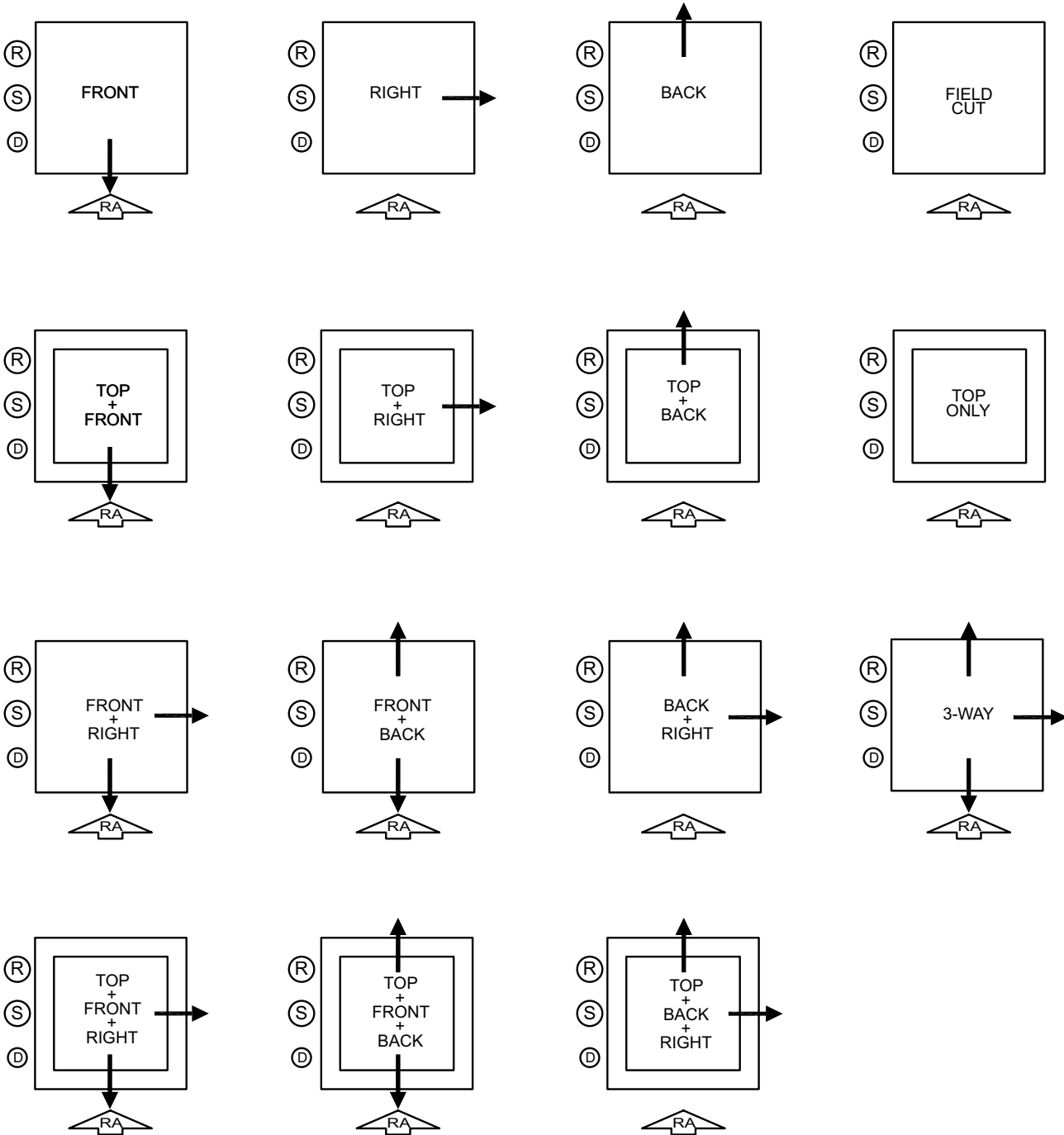

NOTES:

- 1) RETURN AIR OPENING SIDE IS DEFINED AS FRONT OF UNIT (CHASSIS AND CONTROL SERVICE ACCESS).
- 2) 3-WAY DISCHARGE ARRANGEMENT IS NOT RECOMMENDED FOR UNIT SIZES 009, 012
- 3) SINGLE DISCHARGE OPENING (EXCEPT TOP DISCHARGE) IS NOT RECOMMENDED FOR UNIT SIZES 030, 036

REAR RISER

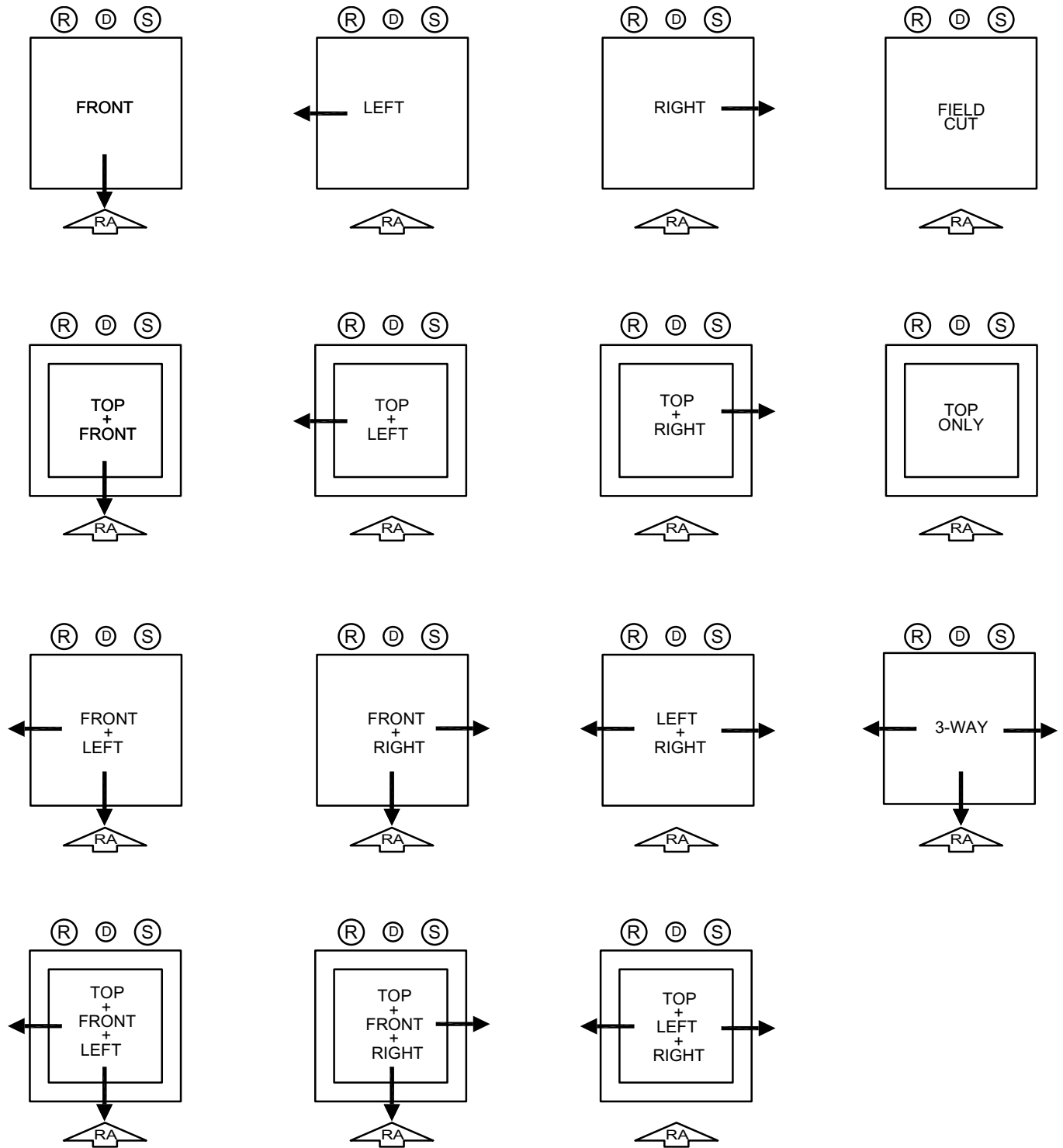

NOTES:

- 1) RETURN AIR OPENING SIDE IS DEFINED AS FRONT OF UNIT (CHASSIS AND CONTROL SERVICE ACCESS).
- 2) 3-WAY DISCHARGE ARRANGEMENT IS NOT RECOMMENDED FOR UNIT SIZES 009, 012
- 3) SINGLE DISCHARGE OPENING (EXCEPT TOP DISCHARGE) IS NOT RECOMMENDED FOR UNIT SIZES 030, 036

Wiring Diagram

VSCS SERIES w/ PSC MOTOR
208-230V, 265V/1Ph/60Hz

Mar 24,2015

- LEGEND:**
- S2 - FAN SPEED SWITCH
 - C1 - COMPRESSOR CONTACTOR
 - TRF - 24V CONTROL TRANSFORMER
 - COMP - COMPRESSOR MOTOR
 - EFM - EVAP. FAN MOTOR
 - Rsv - REVERSING VALVE RELAY
 - R2 - BLOWER RELAY
 - CFT - COAXIAL FREEZE THERMOSTAT
 - HPC - HIGH PRESSURE SWITCH
 - LPC - LOW PRESSURE SWITCH
 - RC - RUN CAPACITOR
 - SV - REVERSING VALVE COIL
 - COS - CONDENSATE OVERFLOW SWITCH
 - MB - MICROPROCESSOR BOARD
 - F6 - TRANSFORMER SECONDARY FUSE
- OPTIONAL:**
- TB1 - LINE VOLTAGE TERMINAL BLOCK
 - MV - MOTORIZED VALVE
 - S1 - LINE VOLTAGE DISCONNECT
 - F1 - LINE VOLTAGE FUSES
 - WP - WATER PUMP
 - DMP - MOTORIZED DAMPER
 - CF - CONTINUOUS FAN OPTION
 - R3 - CONTINUOUS FAN RELAY

1. ALL FIELD WIRING TO BE ACCOMPLISHED FOLLOWING CITY, LOCAL AND/OR NATIONAL CODES IN EFFECT AT TIME OF INSTALLATION OF THIS UNIT
 2. SEE UNIT NAMEPLATE FOR MAXIMUM FUSE AND/OR CIRCUIT BREAKER SIZE AND MINIMUM CIRCUIT AMPACITY
- ⚠ FACTORY WIRED FOR 230 VOLT OPERATION. FOR 208 VOLT, CONNECT HIGH VOLTAGE TO 208V TERMINAL ON TRANSFORMER
 - ⚠ REFER TO INSTALLATION MANUAL FOR UNIT-SPECIFIC FACTORY BLOWER SPEED CONNECTIONS
 - ⚠ FOR LOW TEMPERATURE OPERATION, DISCONNECT CFT, AND INSTALL JUMPER PLUG.

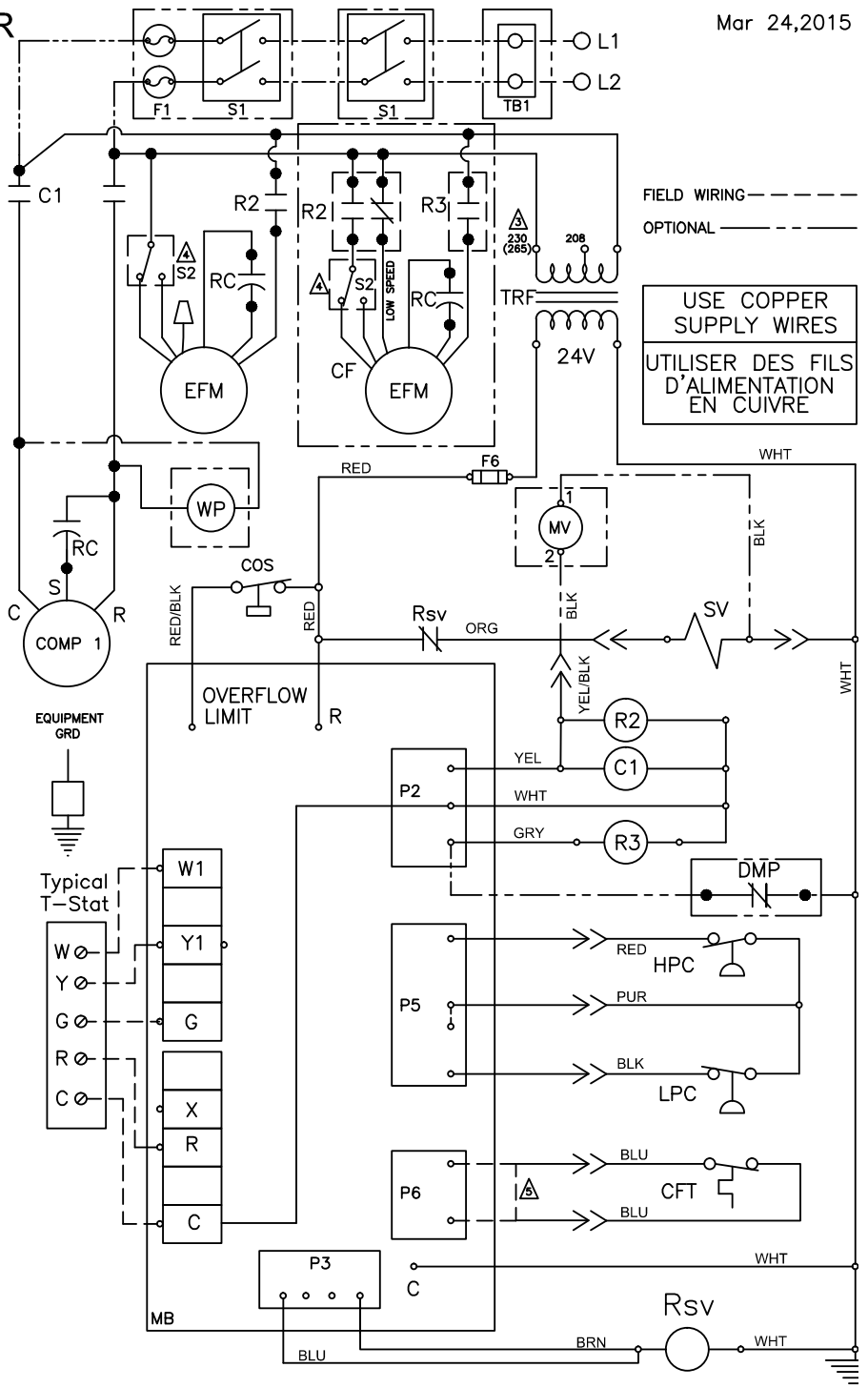

USE COPPER SUPPLY WIRES
UTILISER DES FILS D'ALIMENTATION EN CUIVRE

STK-553

VSCS SERIES w/ ECM MOTOR

208-230V, 265V/1Ph/60Hz

March 24, 2015

LEGEND:

- S2 - FAN SPEED SWITCH
- C1 - COMPRESSOR CONTACTOR
- TRF - 24V CONTROL TRANSFORMER
- COMP - COMPRESSOR MOTOR
- ECM - EVAP. ECM FAN MOTOR
- Rsv - REVERSING VALVE RELAY
- CFT - COAXIAL FREEZE THERMOSTAT
- HPC - HIGH PRESSURE SWITCH
- LPC - LOW PRESSURE SWITCH
- SV - REVERSING VALVE COIL
- COS - CONDENSATE OVERFLOW SWITCH
- MB - MICROPROCESSOR BOARD
- F6 - TRANSFORMER SECONDARY FUSE

OPTIONAL:

- TB1 - LINE VOLTAGE TERMINAL BLOCK
- TB2 - CONTINUOUS FAN TERMINAL BLOCK
- MV - MOTORIZED VALVE
- S1 - LINE VOLTAGE DISCONNECT
- F1 - LINE VOLTAGE FUSES
- WP - WATER PUMP
- DMP - MOTORIZED DAMPER

FIELD WIRING - - - - -
 OPTIONAL - - - - -

USE COPPER SUPPLY WIRES
 UTILISER DES FILS D'ALIMENTATION EN CUIVRE

1. ALL FIELD WIRING TO BE ACCOMPLISHED FOLLOWING CITY, LOCAL AND/OR NATIONAL CODES IN EFFECT AT TIME OF INSTALLATION OF THIS UNIT
 2. SEE UNIT NAMEPLATE FOR MAXIMUM FUSE AND/OR CIRCUIT BREAKER SIZE AND MINIMUM CIRCUIT AMPACITY
- ⚠ FACTORY WIRED FOR 230 VOLT OPERATION. FOR 208 VOLT, CONNECT HIGH VOLTAGE TO 208V TERMINAL ON TRANSFORMER
 - ⚠ REFER TO INSTALLATION MANUAL FOR UNIT-SPECIFIC FACTORY BLOWER SPEED CONNECTIONS
 - ⚠ FOR LOW TEMPERATURE OPERATION, DISCONNECT CFT, AND INSTALL JUMPER PLUG.

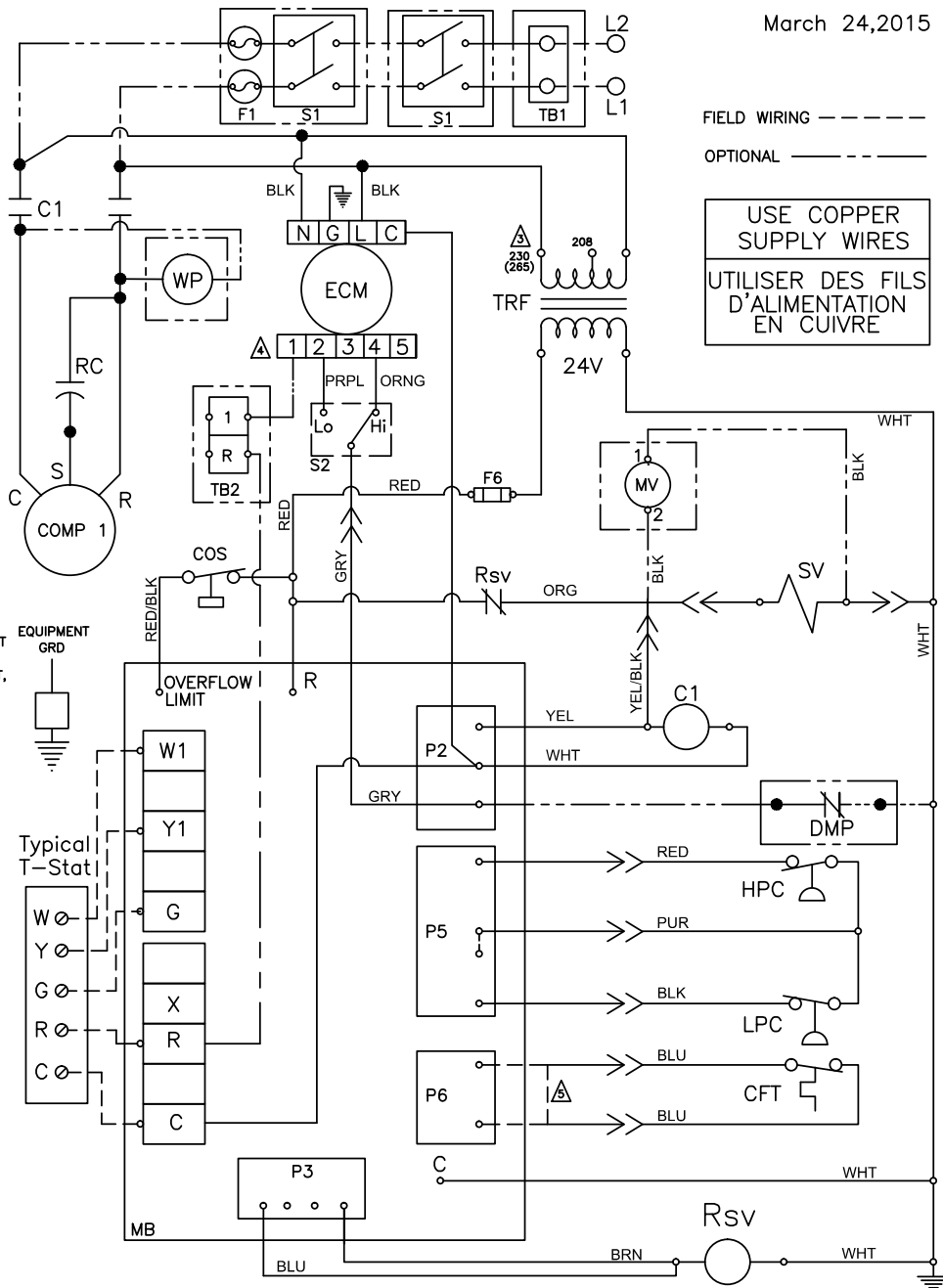

STK-554

THIS PAGE INTENTIONALLY LEFT BLANK.

Specifications

GENERAL

All VSCS-series models ship as a factory-charged package complete with R-410A refrigerant. All units from 3/4 to 3 tons shall be tested and certified by ASHRAE/ANSI/AHRI/ISO 13256-1 and ETL listed for United States and Canada. ASHRAE/ANSI/AHRI/ISO and ETL labels shall be applied prior to leaving the factory. All units are test operated at the factory. Both cabinets and refrigeration chassis are completely factory wired and piped.

CABINET

The self-supporting cabinet assembly is constructed of heavy gauge, corrosion-resistant, coated steel (minimum 20-gauge thickness for exterior panels). The entire cabinet interior is insulated with 1/2-inch thick, high-density thermal and acoustic insulation. Insulation shall meet NFPA 90, UL-181, and ASTM-C1071 standards, have a flame spread of less than 25, and a smoke developed classification of less than 50 per ASTM E-84 and UL 723. A removable inner service panel seals the fan and compressor compartment during operation. The cabinet base section contains a heavy gauge galvanized steel drain pan and 14-gauge guide rails for the slide-in heat-pump chassis. The drain pan outlet is readily accessible for cleaning (removal of inner service panel required). The drain pan comes standard with a normally closed condensate overflow switch. The drain pan outlet, incorporating a P-trap, is factory connected to the condensate riser.

The removable fan and motor assembly is suspended horizontally from an 18-gauge blower mounting deck, which creates an insulated discharge plenum in the upper section of the cabinet. Supply air openings are factory cut according to customer specifications. A noise attenuating insulated privacy air baffle is provided for horizontal supply air openings. All cabinet openings are provided with standard 1-inch drywall flange around the full opening perimeter.

- Optional surface-mount thermostat connection. Allows mounting of the space thermostat directly above the unit's return air panel or mounted remotely (requires optional extended harness). Electrical connection to the unit is by a plug-in Molex pigtail connector. Molex pigtail is field wired to thermostat terminals.
- Optional 4-inch round Outside Air Opening through top of unit (left- or right-hand configurations available). Unit comes with 4 1/4-inch return air flange.
- Optional 4-inch round Outside Air Opening with motorized damper through top of unit (left- or right-hand configurations available). Unit comes with 4 1/4-inch return air flange. Motorized damper is accessible and easily serviced through RA Panel (no additional service door is required).
- Optional Stainless Steel Drain Pan for added corrosion resistance. Entire drain pan is fabricated out of heavy gauge stainless steel.
- Optional 80-inch cabinet. Reduced height cabinet for applications where additional ceiling clearance is required.
- Optional 2-inch cabinet stand. Stand is factory installed to the base of the cabinet.

Specifications (Cont'd)

- Optional 4-inch cabinet stand. Stand is factory installed to the base of the cabinet (80-inch cabinet only).
- Optional 8-inch cabinet stand. Stand is factory installed to the base of the cabinet (80-inch cabinet only).

RISER ASSEMBLY

Full-length supply, return, and condensate risers can be either factory-assembled onto the cabinet or shipped loose on separate skids. Maximum factory installed riser length is 120 inches. When the slab-to-slab dimension for a given floor is in excess of 118 inches, separate riser extension pieces can be factory provided to reach the required total riser length (riser extensions are field installed). The top of all risers and riser extensions is internally expanded (3-inch depth) to allow connection of each subsequent riser section without the use of couplings. Type 'M' copper for risers is standard.

Riser placement may be on any of three sides of the cabinet (right, left, or back). Riser knock-outs are located on all three sides, allowing field conversion of riser placement if necessary. Risers and unit must be installed in such a way to prevent freezing of water.

Risers are internally piped into the cabinet assembly, including ball shut-off valves and threaded hose connection stubs. The condensate drain riser is insulated with 3/8-inch wall thickness closed-cell foam insulation.

- Optional Type 'L' copper risers
- Optional protective riser cover to prevent riser damage during shipping, handling, and installation

REFRIGERATION CHASSIS

Each removable heat-pump chassis assembly includes an air-to-refrigerant coil, a water-to-refrigerant coil, a condensate collection drain pan, and features a high efficiency rotary or scroll compressor. The chassis base is fabricated from heavy gauge galvanized steel (14 Ga). A metal enclosure isolates the compressor from the moving air stream in the lower fan compartment. The compressor enclosure is insulated with 1/2-inch thick, 2-pound density insulation. Insulation shall meet NFPA 90, UL-181, and ASTM-C1071 standards, have a flame spread of less than 25, and a smoke developed classification of less than 50 per ASTM E-84 and UL 723.

Electrical connection between the cabinet and the chassis is by locking quick-connect plugs (separate high voltage and low voltage plugs). Water supply and return connection to the chassis is by factory-supplied reinforced high-pressure flexible hoses with quick-sealing swivel couplings. The hose assemblies are rated for a minimum 350 psig working pressure.

Rotary and scroll compressors are mounted on rubber vibration isolators. Compressor motors are provided with internal overload protection. Each refrigeration circuit is thoroughly evacuated and fully charged with R-410A refrigerant before shipment. An external high-pressure switch and a low-suction temperature switch are included in each compressor control circuit. The sealed refrigeration circuit includes a bi-flow thermal expansion valve, with external equalizer. Service gauge ports are provided for field diagnosis and service. The 4-way reversing valve is a pilot operated, sliding piston type with a replaceable magnetic solenoid coil. Each unit is equipped with a liquid line filter drier.

Refrigerant-to-air heat transfer coils are constructed of internally enhanced copper tubes, mechanically bonded to enhanced aluminum plate fins. The coaxial refrigerant-to water heat exchangers feature a convoluted inner tube design for high heat transfer efficiency. Standard models feature a copper inner tube surrounded by a steel outer tube and carry a 400-psig waterside working pressure rating. Units shall be capable of operation with an entering fluid temperature range of 20°F to 110°F.

- Optional corrosion resistant air-to-refrigerant coil (E-Coat). Coil shall receive a 1-mil thickness of cathodic epoxy type electro-deposit coating to increase corrosion resistance and prevent microbial contamination.
- Optional Cupro-Nickel water coil. Water side coaxial condenser coil shall be constructed of cupro-nickel metal alloy for increased resistance to corrosion and contamination buildup.
- Optional automatic water flow regulator, factory installed as an integral part of the refrigeration chassis. The automatic flow control valve shall be selected for the nominal rated flow rate and provides constant flow over a 2-80 psi differential pressure range.
- Optional Y-strainer with #20 mesh screen is factory installed.
- Optional 2-way water control valve. A factory installed 2-way motorized valve is wired in parallel with the compressor control circuit to shut off water flow to the unit when the compressor is off. This feature can significantly reduce power consumption in variable-speed or staged pumping applications. The valve has standard 25 psi close-off rating (optional 60 psi close-off rated valve is available). The actuator is of a slow-closing design to eliminate hydraulic shock.
- Optional 3-way water control valve. A factory installed 3-way motorized valve is wired in parallel with the compressor control circuit, to shut off water flow to the unit when the compressor is off. This feature allows loop water to circulate back to return column riser when unit is not in operation and can significantly reduce power consumption in variable-speed or staged pumping applications. The valve has standard 25 psi close-off rating (optional 60 psi close-off rated valve is available). The actuator is of a slow-closing design to eliminate hydraulic shock.
- Optional chassis mounted Circulating Pump for single riser systems. Unit chassis is fitted with a circulating pump in applications where supply and return water is circulated in the building through a single riser.
- Optional sound isolated chassis for improved sound performance. Integral to chassis, specially designed chassis rails improve vibrational and sound performance of complete unit (US patent pending).

INDOOR FAN

Forward curved, double inlet and double width, direct-drive centrifugal blowers are used for air movement. Large diameter blower wheels are employed to provide required airflow performance at minimum noise levels. Standard fan motors are PSC types and feature permanently lubricated bearings and internal thermal overload protection. Optional EC motors feature soft start and stop for added occupant comfort, consume less power compared to standard motors, and maintain good fan performance when subjected to higher external static pressures. The fan motors are attached to the blower housings by means of an integral 'flex-mount' system, with additional vibration isolation provided by rubber

Specifications (Cont'd)

mounting grommets. A manual selector switch is accessible through the hinged return air panel, allowing switching between the two available fan speeds (Hi – Low).

- Optional Hi-Static PSC motor and blower assembly for applications with extended ductwork layout.
- Optional EC motor (ECM).
- Optional Hi-Static ECM and blower assembly for applications with extended ductwork layout.
- Optional ECM with Continuous Low Speed fan option. Fan continuously circulates air at low fan speed.
- Optional Hi-Static ECM with Continuous Low Speed fan option. Fan continuously circulates air at low fan speed.

ELECTRICAL/CONTROLS

All units are completely factory wired with all necessary operating controls. A standard factory installed, non-fused, electrical disconnect is provided for service convenience and maintenance.

- Optional Non-Fused Disconnect
- Optional Disconnect with Fusing added to the internal line voltage switch circuit
- 2-Speed Fan Control at Thermostat
- 3-Speed Fan Control at Thermostat (with ECMs only)

Standard unit control consists of a 24-volt electromechanical relay package. The cabinet-mounted electrical box contains a 50VA Class II transformer for field connection. The reversing valve solenoid coil shall be energized in cooling mode only.

The control system microprocessor board is specifically designed for water source heat pump operation. The control system interfaces with a conventional type thermostat.

- Unit shall incorporate a lockout circuit that provides reset capability at the space thermostat, base unit, or by interrupting service power, should any of the following standard safety devices trip and shut off the compressor.
 - Loss-of-charge/Low-pressure switch
 - High-pressure switch
 - Low water temperature protection
 - Condensate overflow protection
- Random start.
- Should the high-pressure or low-pressure safeties open three times within two hours of operation (1 hour for low-pressure safety), then lockout requiring manual reset will occur.
- Should the low water temperature or condensate overflow safeties trip three times sequentially, then lockout requiring manual reset will occur.
- The low-pressure switch shall not be monitored during the initial 30 seconds of a cooling system's operation to prevent nuisance trips.

- Unit shall have capability to defeat time delays for servicing.
- Unit control board shall have on-board diagnostics and an LED fault code display.
- Standard controls shall include anti-short cycle and low voltage protection.
- Control board shall monitor each refrigerant safety switch independently.
- Control board energizes reversing valve solenoid in cooling only.
- Control board shall have random start feature.
- Control board shall retain last five fault codes in non-volatile memory, which will not be lost in the event of a power loss.

In addition to the external pressure switches, the compressor also has inherent (internal) protection. If there is an abnormal temperature or power rise in a compressor, the internal protection will immediately shut down the compressor. The microprocessor control incorporates features to minimize compressor wear and damage. An anti-short cycle delay (ASCD) is utilized to prevent short cycling of the compressor. Additionally, a minimum run time is imposed any time a compressor is energized. The ASCD is initiated on unit start-up and on any compressor reset or lockout.

FILTERS

All units are supplied with a 1-inch thick throwaway filter. Filters are accessible through the hinged return air panel without removing the inner service panel.

- Optional MERV 8 Filters

FIELD INSTALLED ACCESSORIES

Acoustic Return Air Panel

The flush-mounted return air panel is designed to minimize line-of-sight noise transmission. The panel assembly is fabricated from heavy gauge steel. An insulated, hinged center section allows convenient user access to the unit control panel and filter.

The perimeter frame of the panel is mounted to the drywall/framing opening at the front of the cabinet. The heat-pump chassis is fully accessible and removable through the hinged door section. The panel is supplied in standard Appliance White painted finish.

Supply Air Grilles

Optional supply air grilles shall be supplied for each free discharge outlet directly from the cabinet (non-ducted outlets). All unit mounted supply grilles will be supplied as double deflection type. Grilles for unequal airflow applications shall be provided with integral opposed blade dampers (volume dampers). Grilles will be supplied in standard Appliance White painted finish.

Hoses

High-pressure flexible hoses with quick-sealing swivel couplings provide supply and return water connections to the chassis. Hose material is fire-rated (UL-94 VO) thermoplastic inner tube, reinforced by a stainless steel wire outer braid. The hose assemblies are rated for a minimum 350 psig working pressure.

Specifications (Cont'd)

Thermostats

- TEC3000 Series Thermostat

Included features for the TEC3000 series thermostats are:

- Field-selectable BACnet MS/TP or N2 networked communication (TEC36xx-00-000 Models)
- USB port configuration
- Backlit Liquid Crystal Display (LCD)
- Configurable touch screen UI
- Mobile Access Portal (MAP) gateway compatibility (MAP Release 4.0 or Later)
- Stand-alone and BACnet MS/TP or N2 networked models
- Onboard occupancy sensor (TEC3xx1-00-000 and TEC3xx3-00-000 Models)
- Single- or two-stage control
- Full line of remote TE-6300 series temperature sensors

- T701 Series Thermostat

Included features for the T701 series thermostats are:

- Includes Model T701DFN-1 (Non-Programmable) and Model T701DFP-1 (7-Day Programmable)
- Auto-staging fan speed control
- Three speed fan control
- Remote sensor ready
- Dry contact equipped
- Backlit display
- Electric heat ready
- Non-Volatile Memory: all setpoints and programming are permanently stored during power loss
- Dual setpoint with adjustable deadband
- Keypad lockout
- Configurable display
- Display either °F or °C
- Wall plate available
- Self-prompting

- T8000 Series Thermostat

Included features for the T8000 series Color Touchscreen thermostats are:

- Remote control via Wi-Fi with Optional Skyport Cloud Services Wi-Fi Key (ordered separately)
- Switchable programmable or non-programmable
- Programmable occupancy schedule: reduces operating expenses by controlling the room based on occupant schedules
- Up to four heat and two cool stages
- Independently adjustable timers and deadbands for all stages of heating and cooling
- Passcode security for screen lock and setpoint limits
- Programmable fan
- Outdoor sensor ready
- Multi-lingual display options: provide a user interface in English, French, and Spanish
- Weather forecast display capable
- Home/away feature
- Local equipment runtime trending: provides easy access to energy usage information; shows how much energy was used to heat and/or cool over a 7-day period
- SD memory card input: reduces configuration time by making inputting and exporting data between digital room thermostats quick and easy
- Configurable alerts: send messages to the digital room thermostat when certain conditions occur, such as when the room temperature exceeds a user-specified value

