

OMRON

IO-Link System

User's Manual

NOTE

All rights reserved. No part of this publication may be reproduced, stored in a retrieval system, or transmitted, in any form, or by any means, mechanical, electronic, photocopying, recording, or otherwise, without the prior written permission of OMRON.

No patent liability is assumed with respect to the use of the information contained herein. Moreover, because OMRON is constantly striving to improve its high-quality products, the information contained in this manual is subject to change without notice. Every precaution has been taken in the preparation of this manual. Nevertheless, OMRON assumes no responsibility for errors or omissions. Neither is any liability assumed for damages resulting from the use of the information contained in this publication.

Trademarks

- Sysmac and SYSMAC are trademarks or registered trademarks of OMRON Corporation in Japan and other countries for OMRON factory automation products.
- Microsoft, Windows, Windows Vista, Excel, and Visual Basic are either registered trademarks or trademarks of Microsoft Corporation in the United States and other countries.
- EtherCAT® is registered trademark and patented technology, licensed by Beckhoff Automation GmbH, Germany.
- Safety over EtherCAT® is registered trademark and patented technology, licensed by Beckhoff Automation GmbH, Germany.
- ODVA, CIP, CompoNet, DeviceNet, and EtherNet/IP are trademarks of ODVA.

- The SD and SDHC logos are trademarks of SD-3C, LLC.  

Other company names and product names in this document are the trademarks or registered trademarks of their respective companies.

Copyrights

Microsoft product screen shots reprinted with permission from Microsoft Corporation.

Introduction

Thank you for purchasing an NX-series IO-Link Master Unit or GX-series IO-Link Master Unit.

This manual provides information necessary to use NX-series IO-Link Master Units and GX-series IO-Link Master Units to build IO-Link Systems. Please read this manual and make sure you understand the functionality and performance of the NX-series IO-Link Master Unit or GX-series IO-Link Master Unit before you attempt to build an IO-Link System.

Keep this manual in a safe place where it will be available for reference during operation.

Intended Audience

This manual is intended for the following personnel, who must also have knowledge of electrical systems (an electrical engineer or the equivalent).

- Personnel in charge of introducing FA systems
- Personnel in charge of designing FA systems
- Personnel in charge of installing and maintaining FA systems
- Personnel in charge of managing FA systems and facilities

For programming, this manual is intended for personnel who understand the programming language specifications in international standard IEC 61131-3 or Japanese standard JIS B3503.

Applicable Products

This manual covers the following products.

- NX-series IO-Link Master Unit
NX-ILM400
- GX-series IO-Link Master Unit
GX-ILM08C

CONTENTS

Introduction	1
Intended Audience.....	1
Applicable Products.....	1
Relevant Manuals	8
Manual Structure	9
Page Structure and Icons	9
Special Information	10
Precaution on Terminology	10
Terms and Conditions Agreement	12
Warranty, Limitations of Liability	12
Application Considerations	13
Disclaimers	13
Safety Precautions	14
Precautions for Safe Use	16
Precautions for Correct Use.....	17
Regulations and Standards	20
Related Manuals	21
Terminology	25
Revision History	28
Sections in this Manual	29

Section 1 Introduction to IO-Link Systems

1-1 Introduction to and Features of IO-Link Systems	1-2
1-1-1 What Is IO-Link?	1-2
1-1-2 Overview of IO-Link System Configurations	1-2
1-1-3 Introduction to IO-Link Systems.....	1-4
1-1-4 Features of an IO-Link System	1-5
1-2 System Configurations	1-7
1-2-1 Types of Communications with the Controller.....	1-7
1-2-2 Controller Communications with EtherCAT	1-8
1-2-3 Controller Communications with EtherNet/IP.....	1-10
1-2-4 Controller Communications with NX Bus	1-10
1-3 Communications Specifications and IO-Link Devices.....	1-12
1-3-1 Communications Specifications	1-12
1-3-2 OMRON IO-Link Products.....	1-12
1-4 Communications for IO-Link Systems	1-14
1-4-1 Data in the Devices in an IO-Link System and How to Access It.....	1-14
1-4-2 Cyclic Communications.....	1-19
1-4-3 Message Communications.....	1-20
1-5 IO-Link Master Unit Functions	1-21
1-6 Startup Procedures	1-24

1-6-1	Controller Communications with EtherCAT	1-24
1-6-2	Controller Communications with EtherNet/IP	1-29
1-6-3	Controller Communications with NX Bus.....	1-29

Section 2 Part Names and Wiring

2-1	Part Names and Functions	2-2
2-1-1	Appearance of the IO-Link Master Units.....	2-2
2-1-2	Indicators on IO-Link Master Units	2-2
2-1-3	Terminals for Connecting the IO-Link Master Unit to IO-Link Devices.....	2-3
2-2	Communications Modes and IO-Link Wiring	2-5
2-2-1	IO-Link Mode	2-5
2-2-2	SIO (DI) Mode.....	2-6
2-2-3	SIO (DO) Mode.....	2-8
2-3	Supplying Unit Power and I/O Power	2-9
2-3-1	Unit Power Supply and I/O Power Supply Methods	2-9
2-3-2	Calculating the Current Consumption of the IO-Link Master Unit from the I/O Power Supply.....	2-10
2-3-3	Precautions for the Unit Power Supply and the I/O Power Supply	2-11

Section 3 Parameter Settings

3-1	Types of Parameters	3-2
3-2	IO-Link Master Unit Parameters	3-3
3-3	Parameters for IO-Link Devices	3-6

Section 4 I/O Data

4-1	Outline of I/O Data	4-2
4-1-1	Introduction to I/O Data and Types of I/O Data.....	4-2
4-1-2	Type of I/O Data.....	4-2
4-1-3	Allocated I/O Data According to Communications Mode.....	4-5
4-2	I/O Data Details	4-7
4-2-1	Input Data (from the IO-Link Master Unit to the Controller).....	4-7
4-2-2	Output Data (from the Controller to the IO-Link Master Unit)	4-15
4-3	I/O Allocation Settings	4-17
4-3-1	What Are I/O Allocation Settings?	4-17
4-3-2	When Are I/O Allocation Settings Required?.....	4-17
4-3-3	I/O Allocation Setting Method	4-18
4-4	Specifying I/O Data in the User Program.....	4-19
4-4-1	Controller Communications Using EtherCAT (NX-type IO-Link Master Unit or GX-type IO-Link Master Unit)	4-19
4-4-2	Controller Communications Using EtherNet/IP (NX-type IO-Link Master Unit)	4-19
4-4-3	Controller Communications Using NX bus (NX-type IO-Link Master Unit).....	4-19

Section 5 Status and Software Switches Other Than for I/O Data

5-1	Overview of Status and Software Switches Other Than for I/O Data and Their Types ...	5-2
5-2	Details on Status and Software Switches Other Than for I/O Data	5-3

Section 6 IO-Link System Communications

6-1	Types and Startup of Communications for IO-Link Systems	6-2
6-1-1	Types of Communications for IO-Link Systems	6-2
6-1-2	Starting Communications between the Controller and the IO-Link Master	6-2
6-1-3	Starting IO-Link Communications between the IO-Link Master Unit and the IO-Link Devices.....	6-3
6-2	Cyclic Communications	6-5
6-2-1	Overview of Cyclic Communications.....	6-5
6-2-2	Start Timing of Cyclic Communications in IO-Link Communications.....	6-6
6-2-3	Writing a Program for Cyclic Communications for IO-Link Communications	6-6
6-2-4	Stopping IO-Link Cyclic Communications	6-7
6-2-5	Operation When an IO-Link Device Is Disconnected.....	6-7
6-2-6	Cycle Communications Response Performance.....	6-7
6-3	Message Communications	6-8
6-3-1	Introduction to Message Communications.....	6-8
6-3-2	Message Communications with the IO-Link Master	6-9
6-3-3	Message Communications with IO-Link Devices	6-12

Section 7 Functions of IO-Link Master Units

7-1	Communications Mode Settings	7-2
7-1-1	Functions Supported by Each Communications Mode	7-2
7-1-2	Setting Methods	7-4
7-2	Connected Device Verification	7-6
7-2-1	Overview	7-6
7-2-2	Setting Method.....	7-7
7-3	Load Rejection for Controller Communications Errors	7-9
7-3-1	Introduction	7-9
7-3-2	Setting Method.....	7-10
7-4	IO-Link Total Communications Lost Frames	7-11
7-4-1	Introduction	7-11
7-4-2	Application Method.....	7-11
7-5	Digital Input Filter	7-13
7-5-1	Introduction	7-13
7-5-2	Setting Method.....	7-13
7-6	Backup and Restoration of Parameter Settings in IO-Link Devices	7-14
7-6-1	Overview of Backup and Restore Operations	7-14
7-6-2	Backing Up Settings.....	7-15
7-6-3	Restoring Settings.....	7-20
7-6-4	Conditions for Backing Up and Restoring Parameter Settings When IO-Link Communications Start	7-21
7-6-5	Clearing Backup Data	7-21
7-6-6	Application Procedure	7-24
7-7	Digital Input Collection	7-25
7-7-1	Overview	7-25
7-7-2	Setting Method	7-27

Section 8 Applicable Support Software for IO-Link Systems

8-1	Applications and Types of the Support Software	8-2
8-2	Sysmac Studio Procedures	8-4
8-2-1	Flow of Operations on the Sysmac Studio	8-4
8-2-2	Setting Parameters in the IO-Link Master Unit.....	8-7
8-2-3	Changing I/O Data Sizes in the IO-Link Master Unit.....	8-8
8-3	NX-IO Configurator Procedures	8-13

8-3-1	Setting Parameters in the IO-Link Master Unit	8-13
8-3-2	Changing I/O Data Sizes in the IO-Link Master Unit	8-13
8-4	CX-ConfiguratorFDT Procedures	8-14
8-4-1	Overview of CX-ConfiguratorFDT	8-14
8-4-2	Flow of Operations for CX-ConfiguratorFDT	8-15
8-4-3	Installing CX-ConfiguratorFDT in Your Computer	8-16
8-4-4	Installing IODD Files for IO-Link Devices from Other Companies in CX-ConfiguratorFDT	8-16
8-4-5	Starting CX-ConfiguratorFDT	8-17
8-4-6	Creating the Network Configuration	8-18
8-4-7	Going Online	8-24
8-4-8	Transferring the IO-Link Device Parameters	8-36

Section 9 Example of Operations for IO-Link Systems

9-1	Assumed Configuration	9-2
9-2	System Configuration Example	9-3
9-3	Controller Communications Setup	9-5
9-4	IO-Link Master Unit Settings	9-6
9-5	Allocating Variables to the I/O Ports	9-7
9-6	Programming	9-9
9-6-1	Reading Input Data from Sensors	9-9
9-7	Turning ON the Power	9-12
9-8	Downloading the Network Configuration Information and the User Program	9-13
9-9	Setting IO-Link Device Parameters and Downloading Them to the IO-Link Devices ...	9-14
9-10	Confirming the Start of Communications	9-15

Section 10 Troubleshooting for IO-Link Systems

10-1	IO-Link Error and Device Error Notifications and Checking Methods	10-2
10-1-1	Overview	10-2
10-1-2	Checking for Errors	10-6
10-1-3	Error Notification with the I/O Port Error Status in the I/O Data	10-7
10-1-4	Error Notification with the Sysmac Error Status in the I/O Data	10-7
10-1-5	Error Notification with Emergency Messages (GX-type IO-Link Master Units Only)	10-8
10-1-6	Error Notifications Based on the AL Status (GX-type IO-Link Master Units Only)	10-10
10-1-7	Checking for Errors and Troubleshooting with the Indicators on the Front Panel of the IO-Link Master Unit	10-12
10-1-8	Assumed Causes and Corrections for Other Errors	10-17
10-2	Checking for Errors and Troubleshooting with Tools	10-18
10-2-1	Checking for Errors from the Sysmac Studio	10-18
10-2-2	Checking for Errors from Support Software Other Than the Sysmac Studio	10-19
10-2-3	Sysmac Event Codes and Troubleshooting	10-20
10-2-4	Reading Event Logs from a Tool	10-46
10-2-5	Clearing Event Logs from a Tool	10-47
10-2-6	Exporting Event Logs from a Tool	10-48
10-3	Backing Up Settings and Replacing Units	10-49
10-3-1	Backup and Restore Methods	10-49
10-3-2	Replacing the IO-Link Master Unit or IO-Link Devices	10-51
10-3-3	Replacing the IO-Link Master Unit and IO-Link Devices at the Same Time	10-53

Appendices

A-1	Other System Configurations	A-2
A-1-1	Using a Controller from Another Company with EtherCAT Communications	A-2
A-1-2	Using an NJ/NX-series CPU Unit or NY-series Industrial PC with EtherNet/IP Communications	A-10
A-1-3	Using a CJ/CP/CS-series PLC or a Controller from Another Company with EtherNet/IP Communications	A-16
A-2	Connected Device Specifications and Models	A-24
A-3	How to Access the IO-Link Devices with Message Communications	A-28
A-3-1	Applicable System Configurations	A-28
A-3-2	Overview of Access Methods.....	A-29
A-3-3	Details on Access Methods.....	A-33
A-4	Precautions When Using the OMRON EtherNet/IP with CX-ConfiguratorFDT	A-39

Index

Relevant Manuals

The following table lists the relevant manuals for the IO-Link System.

Read all of the manuals that are relevant to your system configuration and application to make the most of the IO-Link System

Other manuals, such as related product manuals, are necessary for specific system configurations and applications. Refer to *Related Manuals* on page 21 for the related manuals.

Manual name	Application
IO-Link System User's Manual	Learning everything from an introduction to details about IO-Link Systems, including mainly software information common to all IO-Link masters, Support Software operating methods, and troubleshooting.
NX-series IO-Link Master Unit User's Manual	Learning hardware information, wiring, and specifications for the NX-series IO-Link Master Unit and checking a list of NX objects.
GX-series EtherCAT Slave Units User's Manual	Learning how to use GX-series EtherCAT Slave Terminals.
NX-series Data Reference Manual	Referring to the list of data required for NX-series unit system configuration.

Manual Structure

Page Structure and Icons

The following page structure and icons are used in this manual.

The diagram illustrates the structure of a manual page with the following components and annotations:

- Level 1 heading:** 4 Installation and Wiring
- Level 2 heading:** 4-3 Mounting Units
- Level 3 heading:** 4-3-1 Connecting Controller Components
- A step in procedure:** 1 Join the Units so that the connectors fit exactly. Indicates a procedure.
- Special information:** Precautions for Correct Use. Icons indicate precautions, additional information, or reference information.
- Manual name:** NJ-series CPU Unit Hardware User's Manual (W500)
- Page tab:** 4. Gives the number of the main section.

Additional annotations on the right side of the diagram:

- Level 2 heading
- Level 3 heading
- Give the current headings.
- Page tab
- Gives the number of the main section.

Note This illustration is provided only as a sample. It may not literally appear in this manual.

Special Information

Special information in this manual is classified as follows:



Precautions for Safe Use

Precautions on what to do and what not to do to ensure safe usage of the product.



Precautions for Correct Use

Precautions on what to do and what not to do to ensure proper operation and performance.



Additional Information

Additional information to read as required.

This information is provided to increase understanding or make operation easier.



Version Information

Information on differences in specifications and functionality for CPU Units, Industrial PCs, and Communications Coupler Units with different unit versions and for different versions of the Support Software is given.

Note References are provided to more detailed or related information.

Precaution on Terminology

- In this manual, “download” refers to transferring data from the Support Software to a physical device and “upload” refers to transferring data from a physical device to the Support Software.
- In this manual, the directions in relation to the Units are given in the following figure, which shows upright installation.

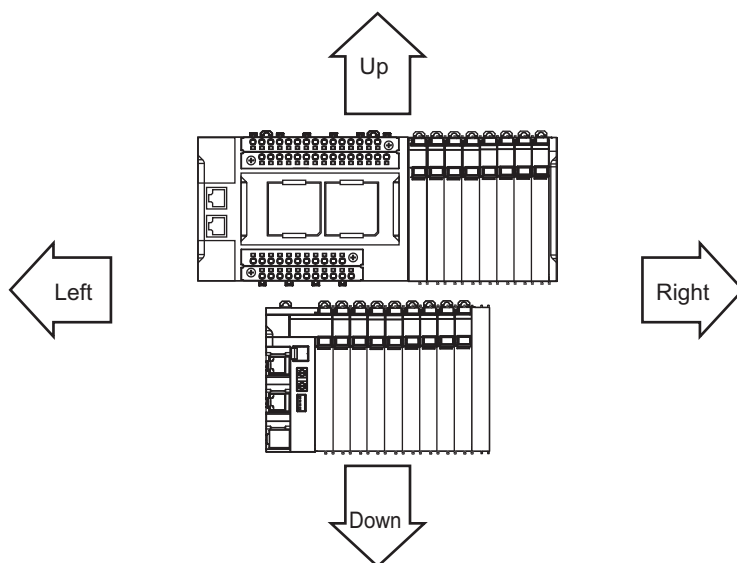

- This user's manual refers to NY-series IPC Machine Controller Industrial Panel PCs and Industrial Box PCs as simply *Industrial PCs* or as *NY-series Industrial PCs*.
- This user's manual refers to the built-in EtherCAT port on an NJ/NX-series Controller or NY-series Industrial PC as simply a *built-in EtherCAT port*.
- This user's manual may omit manual names and manual numbers in places that refer to the user's manuals for CPU Units and Industrial PCs. The following table gives some examples. When necessary, refer to *Related Manuals* on page 21 to determine the appropriate manual based on the common text for the omitted contents.

Examples

Manual name	Omitted contents	Common text
NJ/NX-series CPU Unit Software User's Manual	Software user's manual for the connected CPU Unit or Industrial PC	Software User's Manual
NY-series IPC Machine Controller Industrial Panel PC/Industrial Box PC Software User's Manual		
NJ/NX-series CPU Unit Built-in EtherCAT® Port User's Manual	User's manual for the built-in EtherCAT port on the connected CPU Unit or Industrial PC	Built-in EtherCAT port
NY-series IPC Machine Controller Industrial Panel PC/Industrial Box PC Built-in EtherCAT® Port User's Manual		

- This user's manual may omit manual names and manual numbers in places that refer to the user's manuals for Communications Coupler Units. If you will use a Communications Coupler Unit, refer to *Related Manuals* on page 21 to identify the manual for your Unit.

Terms and Conditions Agreement

Warranty, Limitations of Liability

Warranties

● Exclusive Warranty

Omron's exclusive warranty is that the Products will be free from defects in materials and workmanship for a period of twelve months from the date of sale by Omron (or such other period expressed in writing by Omron). Omron disclaims all other warranties, express or implied.

● Limitations

OMRON MAKES NO WARRANTY OR REPRESENTATION, EXPRESS OR IMPLIED, ABOUT NON-INFRINGEMENT, MERCHANTABILITY OR FITNESS FOR A PARTICULAR PURPOSE OF THE PRODUCTS. BUYER ACKNOWLEDGES THAT IT ALONE HAS DETERMINED THAT THE PRODUCTS WILL SUITABLY MEET THE REQUIREMENTS OF THEIR INTENDED USE.

Omron further disclaims all warranties and responsibility of any type for claims or expenses based on infringement by the Products or otherwise of any intellectual property right.

● Buyer Remedy

Omron's sole obligation hereunder shall be, at Omron's election, to (i) replace (in the form originally shipped with Buyer responsible for labor charges for removal or replacement thereof) the non-complying Product, (ii) repair the non-complying Product, or (iii) repay or credit Buyer an amount equal to the purchase price of the non-complying Product; provided that in no event shall Omron be responsible for warranty, repair, indemnity or any other claims or expenses regarding the Products unless Omron's analysis confirms that the Products were properly handled, stored, installed and maintained and not subject to contamination, abuse, misuse or inappropriate modification. Return of any Products by Buyer must be approved in writing by Omron before shipment. Omron Companies shall not be liable for the suitability or unsuitability or the results from the use of Products in combination with any electrical or electronic components, circuits, system assemblies or any other materials or substances or environments. Any advice, recommendations or information given orally or in writing, are not to be construed as an amendment or addition to the above warranty.

See <http://www.omron.com/global/> or contact your Omron representative for published information.

Limitation on Liability; Etc

OMRON COMPANIES SHALL NOT BE LIABLE FOR SPECIAL, INDIRECT, INCIDENTAL, OR CONSEQUENTIAL DAMAGES, LOSS OF PROFITS OR PRODUCTION OR COMMERCIAL LOSS IN ANY WAY CONNECTED WITH THE PRODUCTS, WHETHER SUCH CLAIM IS BASED IN CONTRACT, WARRANTY, NEGLIGENCE OR STRICT LIABILITY.

Further, in no event shall liability of Omron Companies exceed the individual price of the Product on which liability is asserted.

Application Considerations

Suitability of Use

Omron Companies shall not be responsible for conformity with any standards, codes or regulations which apply to the combination of the Product in the Buyer's application or use of the Product. At Buyer's request, Omron will provide applicable third party certification documents identifying ratings and limitations of use which apply to the Product. This information by itself is not sufficient for a complete determination of the suitability of the Product in combination with the end product, machine, system, or other application or use. Buyer shall be solely responsible for determining appropriateness of the particular Product with respect to Buyer's application, product or system. Buyer shall take application responsibility in all cases.

NEVER USE THE PRODUCT FOR AN APPLICATION INVOLVING SERIOUS RISK TO LIFE OR PROPERTY OR IN LARGE QUANTITIES WITHOUT ENSURING THAT THE SYSTEM AS A WHOLE HAS BEEN DESIGNED TO ADDRESS THE RISKS, AND THAT THE OMRON PRODUCT(S) IS PROPERLY RATED AND INSTALLED FOR THE INTENDED USE WITHIN THE OVERALL EQUIPMENT OR SYSTEM.

Programmable Products

Omron Companies shall not be responsible for the user's programming of a programmable Product, or any consequence thereof.

Disclaimers

Performance Data

Data presented in Omron Company websites, catalogs and other materials is provided as a guide for the user in determining suitability and does not constitute a warranty. It may represent the result of Omron's test conditions, and the user must correlate it to actual application requirements. Actual performance is subject to the Omron's Warranty and Limitations of Liability.

Change in Specifications

Product specifications and accessories may be changed at any time based on improvements and other reasons. It is our practice to change part numbers when published ratings or features are changed, or when significant construction changes are made. However, some specifications of the Product may be changed without any notice. When in doubt, special part numbers may be assigned to fix or establish key specifications for your application. Please consult with your Omron's representative at any time to confirm actual specifications of purchased Product.

Errors and Omissions



Information presented by Omron Companies has been checked and is believed to be accurate; however, no responsibility is assumed for clerical, typographical or proofreading errors or omissions.

Safety Precautions





Definition of Precautionary Information

The following notation is used in this manual to provide precautions required to ensure safe usage of an IO-Link System. The safety precautions that are provided are extremely important to safety. Always read and heed the information provided in all safety precautions.

The following notation is used.

 WARNING	Indicates a potentially hazardous situation which, if not avoided, could result in death or serious injury. Additionally, there may be severe property damage.
 Caution	Indicates a potentially hazardous situation which, if not avoided, may result in minor or moderate injury, or property damage.

Symbols

	The circle and slash symbol indicates operations that you must not do. The specific operation is shown in the circle and explained in text. This example indicates prohibiting disassembly.
	The triangle symbol indicates precautions (including warnings). The specific operation is shown in the triangle and explained in text. This example indicates a precaution for electric shock.
	The triangle symbol indicates precautions (including warnings). The specific operation is shown in the triangle and explained in text. This example indicates a general precaution.
	The filled circle symbol indicates operations that you must do. The specific operation is shown in the circle and explained in text. This example shows a general precaution for something that you must do.
	The triangle symbol indicates precautions (including warnings). The specific operation is shown in the triangle and explained in text. This example indicates a precaution for high temperatures.

WARNING

Refer to the user's manuals for the IO-Link Master Units for warnings that are specific to the IO-Link Master Units.

Cautions

Refer to the user's manuals for the IO-Link Master Units for precautions that are specific to the IO-Link Master Units.

Precautions for Safe Use

This section provides safety precautions for IO-Link Systems.

Refer to the user's manuals for the IO-Link Master Units for safety precautions that are specific to the IO-Link Master Units.

Setting Ports on an IO-Link Master Unit

Do not connect a non-IO-Link actuator to a port that is set to IO-Link Mode. Depending on the operation to establish IO-Link communications, the actuator may unexpectedly and repeatedly turn ON and OFF in a short cycle.

Setting Digital Input Collection

- When you use the digital input collection in IO-Link Mode, set the **Digital Input Collection Setting** to *Enable*. If it is set to *Disable*, the digital input data for pin 2 will be input for the digital input data and the digital input data may become unintended input values. Furthermore, always sufficiently check the **Offset Setting of Digital Input Collection** and then make the setting. If it is set incorrectly, the digital input data may become unintended input values.
- When you do not use the digital input collection in IO-Link Mode, set the **Digital Input Collection Setting** to *Disable*. If it is set to *Enable*, the bit data specified in the input data from the IO-Link device will be input for the digital input data and the digital input data may become unintended input values.

Precautions for Correct Use

This section provides application precautions for IO-Link Systems.

Refer to the user's manuals for the IO-Link Master Units for application precautions that are specific to the IO-Link Master Units.

Setting Ports on an IO-Link Master Unit

- When you connect devices to an IO-Link Master Unit, check the following settings for the ports on the IO-Link Master Unit.
 - Communications Mode Settings: IO-Link Mode, SIO (DI) Mode, and SIO (DO) Mode
 - IO-Link Device Configuration Settings: Device ID, vendor ID, serial number, IO-Link revision, IO-Link input data size, and IO-Link output data size
- The following operation will occur if the communications mode setting does not match the connected device type.
 - If a non-IO-Link sensor is connected in IO-Link Mode, the sensor will operate but the IO-Link Master Unit will not read the ON/OFF signals. An error will not be detected. If connected device verification is enabled, an IO-Link communications error will occur.
 - If a non-IO-Link actuator is connected in IO-Link Mode, the actuator will perform unexpected operation. If connected device verification is enabled, an IO-Link communications error will occur.
 - If an IO-Link device is connected in SIO (DO) Mode, the IO-Link device will not operate. An error will not be detected.
 - If an IO-Link device is connected in SIO (DI) Mode, the IO-Link device will operate in Standard I/O Mode (SIO Mode).
 - If a non-IO-Link actuator is connected in SIO (DI) Mode, the actuator will not operate.
 - If a non-IO-Link sensor is connected in SIO (DO) Mode, the sensor will not operate.

IO-Link Device Verification Settings

To check the configuration when you replace devices, enable verification with the IO-Link Device Verification Setting. If you do not enable verification with the IO-Link Device Verification Setting, errors will not be detected for an IO-Link System even if unwanted IO-Link devices are connected.

I/O Data Size Settings for IO-Link Devices and IO-Link Master Units

● IO-Link Device Configuration Settings

- Observe the following precautions when you manually set the I/O data sizes for IO-Link devices in the IO-Link Device Configuration Settings in the parameters of the IO-Link Master Unit from the Support Software.
 - Set the IO-Link input data sizes in the IO-Link Device Configuration Settings to values that are equal to or greater than the IO-Link input data sizes of the IO-Link devices. If you set a value that is less than the input data size of an IO-Link device, a device I/O size error will occur.
 - Set the IO-Link output data sizes in the IO-Link Device Configuration Settings to values that are equal to or greater than the IO-Link output data sizes of the IO-Link devices. If you set a value that is less than the output data size of an IO-Link device, a device I/O size error will occur.

● I/O Allocation Settings in IO-Link Master Units

- Observe the following precautions when you use the Support Software to set I/O allocations in IO-Link Master Units.
 - Set the IO-Link input allocation data size in I/O allocations settings in the IO-Link Master Unit to a value that is equal to or greater than the IO-Link input data size input to the IO-Link Master Unit. If you set a value that is less than the IO-Link input data size of the IO-Link Master Units, only the set size of data will be input to the controller.
 - Set the IO-Link output allocation data size in I/O allocations settings in the IO-Link Master Unit to a value that is equal to or greater than the IO-Link output data size of the IO-Link Master Unit. If you set a value that is less than the output data size of the IO-Link Master Units, an error will occur.

Programming Cyclic Communications

You must use the TRUE status of the Input Data Enabled Flag in the I/O data as a condition for processing the IO-Link process input data in IO-Link Mode in the user program of the controller.

Processing IO-Link Communications Errors

If an error occurs in IO-Link communications, IO-Link process input data in the IO-Link Master Unit retains the previous values. To prevent malfunctions, write the user program so that IO-Link data processing is not performed when the Input Data Enabled Flag is FALSE.

Replacing IO-Link Devices

Always turn OFF the I/O power supply before you replace an IO-Link device.

Changing IO-Link Device Parameter after Backing Up Parameter Settings

If you change any settings in an IO-Link device after backing up the parameter settings in the IO-Link devices to the IO-Link Master Unit, back up the parameter settings again. If you do not back up the parameter settings, the parameter settings of the IO-Link device that were changed will be overwritten by the backup data from before the settings of the IO-Link Master Unit were changed if restoring settings is enabled in the Restoration Setting when IO-Link communications start.

Backing Up the Parameters from the IO-Link Devices to the IO-Link Master Unit

The parameter settings of the IO-Link devices are not backed up, restored, or verified when the parameter settings of the IO-Link Master Unit are backed up, restored, or verified to an SD Memory Card^{*1} or the Sysmac Studio. Use the CX-ConfiguratorFDT to load the device parameters and save the device parameters.

*1. For an NY-series Industrial PC, this is a Virtual SD Memory Card.

Regulations and Standards

Refer to the user's manuals for the IO-Link Master Units.

Related Manuals

The following table shows related manuals. Use these manuals for reference.

Refer to the instructions for the individual Sensors for information on IO-Link Sensors.

Manual name	Cat. No.	Models	Application	Contents
IO-Link System User's Manual (this manual)	W570	NX-ILM400 GX-ILM08C	Learning everything from an introduction to details about IO-Link Systems, including mainly software information common to all IO-Link masters, Support Software operating methods, and troubleshooting.	Introduces IO-Link Systems and describes system configurations, communications specifications, communications methods, I/O data, parameters, functions, Support Software, and troubleshooting.
NX-series IO-Link Master Unit User's Manual	W567	NX-ILM400	Learning hardware information on the NX-series IO-Link Master Unit and checking a list of NX objects.	Describes detailed part specifications, installation, and wiring and also provides tables of specifications and NX objects for the NX-series IO-Link Master Unit.
GX-series EtherCAT® Slave Unit User's Manual	W488	GX-ID□□□□ GX-OD□□□□ GX-OC□□□□ GX-MD□□□□ GX-AD□□□□ GX-DA□□□□ GX-EC□□□□ GX-ILM□□□ XWT-ID□□ XWT-OD□□	Learning hardware information, wiring, and specifications for the GX-series IO-Link Master Unit and checking a list of objects (W488-E1-05 or later). Or, learning how to use GX-series EtherCAT Slave Terminals.	Describes part names, functions, installation, and wiring and also provides tables of specifications and objects for the GX-series IO-Link Master Unit (W488-E1-05 or later). Also describes the hardware, setup methods, and functions of the EtherCAT Remote I/O Terminals.
NJ/NX-series Instructions Reference Manual	W502	NX701-□□□□ NX102-□□□□ NX1P2-□□□□ NJ501-□□□□ NJ301-□□□□ NJ101-□□□□	Learning detailed specifications on the basic instructions of an NJ/NXseries CPU Unit.	The instructions in the instruction set (IEC 61131-3 specifications) are described.
NY-series Instructions Reference Manual	W560	NY532-1□□□ NY512-1□□□	Learning detailed specifications on the basic instructions of an NY-series Industrial PC.	The instructions in the instruction set (IEC 61131-3 specifications) are described.
NJ/NX-series CPU Unit Built-in EtherCAT® Port User's Manual	W505	NX701-□□□□ NX102-□□□□ NX1P2-□□□□ NJ501-□□□□ NJ301-□□□□ NJ101-□□□□	Using the built-in EtherCAT port on an NJ/NX-series CPU Unit.	Information on the built-in EtherCAT port is provided.

Manual name	Cat. No.	Models	Application	Contents
NY-series IPC Machine Controller Industrial Panel PC / Industrial Box PC Built-in EtherCAT® Port User's Manual	W562	NY532-1□□□ NY512-1□□□	Using the built-in EtherCAT port in an NY-series Industrial PC.	Information on the built-in EtherCAT port is provided. This manual provides an introduction and provides information on the configuration, features, and setup.
NJ/NX-series Troubleshooting Manual	W503	NX701-□□□□ NX102-□□□□ NX1P2-□□□□ NJ501-□□□□ NJ301-□□□□ NJ101-□□□□	Learning about the errors that may be detected in an NJ/NX-series Controller.	Concepts on managing errors that may be detected in an NJ/NX-series Controller and information on individual errors are described.
NY-series Troubleshooting Manual	W564	NY532-1□□□ NY512-1□□□	Learning about the errors that may be detected in an NY-series Industrial PC.	Concepts on managing errors that may be detected in an NY-series Controller and information on individual errors are described.
NX-series Data Reference Manual	W525	NX-□□□□□□	Referencing lists of the data that is required to configure systems with NX-series Units	Lists of the power consumptions, weights, and other NX Unit data that is required to configure systems with NX-series Units are provided.
NX-series EtherCAT® Coupler Unit User's Manual	W519	NX-ECC□□□	Learning how to use an NX-series EtherCAT Coupler Unit and EtherCAT Slave Terminals	The system and configuration of EtherCAT Slave Terminals, which consist of an NX-series EtherCAT Coupler Unit and NX Units, are described along with the hardware, setup, and functions of the EtherCAT Coupler Unit that are required to configure, control, and monitor NX Units through EtherCAT.
NX-series EtherNet/IP™ Coupler Unit User's Manual	W536	NX-EIC202	Learning how to use an NX-series EtherNet/IP Coupler Unit and EtherNet/IP Slave Terminals.	The following items are described: the overall system and configuration methods of an EtherNet/IP Slave Terminal (which consists of an NX-series EtherNet/IP Coupler Unit and NX Units), and information on hardware, setup, and functions to set up, control, and monitor NX Units.

Manual name	Cat. No.	Models	Application	Contents
NX-series NX102 CPU Unit Hardware User's Manual	W593	NX102-□□□□	Learning the basic specifications of the NX-series NX102 CPU Units, including introductory information, designing, installation, and maintenance. Mainly hardware information is provided.	<p>An introduction to the entire NX102 CPU Unit system is provided along with the following information on the CPU Unit.</p> <ul style="list-style-type: none"> • Features and system configuration • Overview • Part names and functions • General specifications • Installation and wiring • Maintenance and inspection
NX-series NX1P2 CPU Unit Hardware User's Manual	W578	NX1P2-□□□□	<p>Learning the basic specifications of the NX-series NX1P2 CPU Units, including introductory information, designing, installation, and maintenance.</p> <p>Mainly hardware information is provided.</p>	<p>An introduction to the entire NX1P system is provided along with the following information on the NX1P2 CPU Unit.</p> <ul style="list-style-type: none"> • Features and system configuration • Introduction • Part names and functions • General specifications • Installation and wiring • Maintenance and inspection
NJ/NX-series CPU Unit Software User's Manual	W501	NX701-□□□□ NX102-□□□□ NX1P2-□□□□ NJ501-□□□□ NJ301-□□□□ NJ101-□□□□	<p>Learning how to program and set up an NJ/NX-series CPU Unit.</p> <p>Mainly software information is provided.</p>	<p>The following information is provided on a Controller built with an NJ/NX-series CPU Unit.</p> <ul style="list-style-type: none"> • CPU Unit operation • CPU Unit features • Initial settings • Programming based on IEC 61131-3 language specifications
NY-series IPC Machine Controller Industrial Panel PC / Industrial Box PC Software User's Manual	W558	NY532-□□□□ NY512-□□□□	<p>Learning how to program and set up the Controller functions of an NY-series Industrial PC.</p>	<p>The following information is provided on the NY-series Controller functions.</p> <ul style="list-style-type: none"> • Controller operation • Controller features • Controller settings • Programming based on IEC 61131-3 language specifications
Sysmac Studio Version 1 Operation Manual	W504	SYSMAC-SE2□□□□	<p>Learning about the operating procedures and functions of the Sysmac Studio.</p>	<p>Describes the operating procedures of the Sysmac Studio.</p>
NX-IO Configurator Operation Manual	W585	CXONE-AL□□D-V4	<p>Learning about the operating procedures and functions of the NX-IO Configurator.</p>	<p>Describes the operating procedures of the NX-IO Configurator.</p>

Manual name	Cat. No.	Models	Application	Contents
E3Z-□8□-IL□ Photoelectric Sensor Index List	9541795-1	E3Z-□8□-IL□	Learning the vendor IDs, device IDs, I/O data (process data), and objects (service data).	Describes the following details for the E3Z-□8□-IL□. <ul style="list-style-type: none"> • IO-Link physical layer • Device IDs • Process data • Service data • Event function
E3Z-□8□-IL□ Proximity Sensor Index List	9540292-0	E2E(Q)-□-IL□	Learning the vendor IDs, device IDs, I/O data (process data), and objects (service data).	Describes the following details for the E2E(Q)-□-IL□. <ul style="list-style-type: none"> • IO-Link physical layer • Device IDs • Process data • Service data • Event function
E3Z-□8□-IL□ Color Mark Sensor Index List	9539397-1	E3S-DCP21-IL□	Learning the vendor IDs, device IDs, I/O data (process data), and objects (service data).	Describes the following details for the E3S-DCP21-IL□. <ul style="list-style-type: none"> • IO-Link physical layer • Device IDs • Process data • Service data

Terminology

Term	Meaning
Communications mode	A setting that specifies whether to use a master port either for IO-Link communications, or for digital input signals and digital output signals with general-purpose (i.e., non-IO-Link) devices.
Controller	An OMRON CPU Unit or Industrial PC connected to the IO-Link Master Unit through a field network or NX bus, or a controller from another company.
Cyclic communications	Communications that exchange data in a fixed period with no need for programming.
Device	A generic term for an IO-Link device or non-IO-Link device.
Device configuration verification error	An IO-Link device connected to a port does not match the IO-Link devices in the IO-Link Device Configuration Settings.
Device event	Events that are reported from the IO-Link devices to the IO-Link master with the IO-Link event reporting function. The following two types of events are allocated as I/O data. <ul style="list-style-type: none"> • Error-level device events • Warning-level device event
Device I/O size error	An error that occurs when an IO-Link device with a size that is greater than the I/O size of the device set in the IO-Link master is connected.
Digital input	A digital input from a general-purpose (i.e., non-IO-Link) device that does not use IO-Link communications. It is the same as a digital input signal.
Digital input data	A general term for digital input signal data in SIO (DI) Mode and digital data that is input with pin 2 in IO-Link Mode.
Digital inputs for pin 2	Digital input signals that are input in parallel with IO-Link communications in IO-Link Mode. "Pin 2" is used in the name because pin 2 is used to input the signals.
Digital output	A digital output to a general-purpose (i.e., non-IO-Link) device that does not use IO-Link communications. It is the same as a digital output signal.
Digital output data	Digital output signal data in SIO (DO) Mode.
Error-level device event	An event that is reported to the IO-Link Master Unit when an error is detected for which an IO-Link device cannot continue operation.
I/O cable	A cable that connects an IO-Link Master Unit to an IO-Link device, non-IO-Link sensor, or non-IO-Link actuator that does not support IO-Link.
I/O data	All target data in cyclic communications with the controller. IO-Link Systems contain the following two types of I/O data. <ul style="list-style-type: none"> • Target data in the cyclic communications in the IO-Link Master Unit • Target data in the IO-Link devices for cyclic communications with the IO-Link master
I/O port error status	The error status of the ports. This status is part of the IO-Link master status.
Input data	Data that an IO-Link device inputs to the IO-Link master. It includes the following: <ul style="list-style-type: none"> • IO-Link process input data from communications, digital inputs from pin 2, and digital inputs from general-purpose (non-IO-Link) devices
Input Data Enabled Flag	A flag that indicates whether the IO-Link process input data is enabled or disabled for a port. There is a flag for each port.
IO-Link communications	Whether the IO-Link process input data is enabled or disabled for each port.
IO-Link communications cycle time	A period of cyclic communications in IO-Link communications.
IO-Link communications error	In IO-Link Mode, communications errors such as I/O cable breaks, device disconnections, and noise can occur in IO-Link communications. This is the term that is used for such errors.

Term	Meaning
IO-Link device	<p>A device with a sensor or actuator that can perform IO-Link communications with the IO-Link master.</p> <p>IO-Link devices are simply referred to as devices in IO-Link specifications, but in this manual "IO-Link" is added to distinguish these devices from other communications devices.</p>
IO-Link Device Configuration Settings	<p>This setting information is used to verify the configuration when IO-Link devices are connected. It consists of the vendor ID, device ID, IO-Link revision, and series number.</p>
IO-Link Device Information Area	<p>Information on the connection configuration of the IO-Link devices that are actually connected to the IO-Link master.</p>
IO-Link Device Verification Setting	<p>A setting that specifies whether to verify that the IO-Link devices actually connected to the ports match the IO-Link devices in the IO-Link Device Configuration Settings when IO-Link communications start.</p>
I/O-Link event code	<p>A code for an error detected by an IO-Link device.</p>
IO-Link process input data	<p>Input data from IO-Link communications in IO-Link Mode (i.e., the data that is sent from the IO-Link devices to the IO-Link master).</p>
IO-Link master	<p>A device that performs IO-Link communications with the IO-Link devices in the IO-Link System and simultaneously functions as a slave for controller communications. "IO-Link Master Unit" is used to refer to a specific Unit.</p>
IO-Link Mode	<p>One of the communications mode settings. In this communications mode, IO-Link communications are performed with the IO-Link devices.</p>
IO-Link process output data	<p>Output data from communications in IO-Link Mode (i.e., the data that is sent from the IO-Link master to the IO-Link devices).</p>
IO-Link total communications lost frames	<p>The total of the number of lost frames of IO-Link cyclic communications for a port.</p>
Load rejection for controller communications errors	<p>A function that specifies whether to retain or clear in SIO (DO) Mode, or to disable or continue in IO-Link Mode, outputs from the IO-Link Master Unit during a controller communications error.</p>
Message communications	<p>Communications that are performed only when requested. Message communications are acyclic communications.</p> <p>IO-Link event notifications are not included. Acyclic communications include message communications and event notifications.</p> <p>There are two types of message communications in an IO-Link System: message communications from the controller to the IO-Link master and message communications through the IO-Link master to the IO-Link devices.</p>
Non-IO-Link sensors and actuators	<p>Devices, such as sensors and actuators, that can exchange digital input signals in SIO (DI) Mode and digital output signals in SIO (DO) Mode with the IO-Link master.</p>
Object	<p>Data in the devices that you can access with message communications or cyclic communications.</p> <p>IO-Link Systems contain the following three types of objects.</p> <ul style="list-style-type: none"> • CoE objects in the GX IO-Link Master Unit. • NX objects in the NX IO-Link Master Unit. • IO-Link objects that are used with the IO-Link devices. <p>All objects consist of the following three types of data.</p> <ul style="list-style-type: none"> • I/O data. • Parameters • Status and software switches other than for I/O data
OD	<p>An acronym for on-request data. "On-request data" is an IO-Link term. In this manual, "on-request data" is a general term for parameters of the IO-Link devices together with the status and software switches other than for I/O data. It refers to the objects in IO-Link message communications.</p>
Output data	<p>Data that the IO-Link master outputs to the IO-Link devices. It includes the following:</p> <ul style="list-style-type: none"> • IO-Link process output data from communications and digital outputs to general-purpose (non-IO-Link) devices.

Term	Meaning
PDO mapping error	This flag indicates that an IO-Link Master Unit with a size that is greater than the I/O size in the PDO Map Settings set from the controller is connected.
Pin 2 digital input data	Digital data that is input for pin 2 in IO-Link Mode.
Port	<p>An I/O connection port of the IO-Link master. In this manual, they are simply referred to as ports.</p> <p>Because you can use ports for digital inputs and digital outputs in addition to IO-Link communications, they are not called IO-Link communications ports.</p>
Process data	I/O data in the IO-Link devices. You can allocate a maximum of 32 bytes of process data in the master. A generic term for the IO-Link process input data and IO-Link process output data in IO-Link devices.
SIO	An acronym for standard input/output. SIO is a general term for the communications modes that are used to perform ordinary digital input and output.
SIO (DI) Mode	One of the communications mode settings. In this communications mode, ordinary digital input signals from general-purpose (i.e., non-IO-Link) devices are input.
SIO (DO) Mode	One of the communications mode settings. In this communications mode, ordinary digital output signals to general-purpose (i.e., non-IO-Link) devices are output.
Warning-level device event	There are two types of message communications in an IO-Link System: message communications from the controller to the IO-Link master and message communications through the IO-Link master to the IO-Link devices.

Revision History

A manual revision code appears as a suffix to the catalog number on the front and back covers of the manual.

Cat. No.	W570-E1-05
-----------------	-------------------

↑
Revision code

Revision code	Date	Revised content
01	July 2016	Original production
02	October 2016	<ul style="list-style-type: none"> • Made revisions accompanying the addition of NY-series Industrial PCs (NY-series IPC Machine Controller Industrial Panel PCs and Industrial Box PCs). • Made revisions accompanying the addition of NX-series NX1P2 CPU Units. • Corrected mistakes.
03	June 2017	<ul style="list-style-type: none"> • Made changes accompanying the upgrade of the NX-ECC203 unit version to version 1.5. • Made changes accompanying the upgrade of the NX-EIC202 unit version to version 1.2. • Corrected mistakes.
04	October 2017	<ul style="list-style-type: none"> • Made changes accompanying the upgrade of the IO-Link Master Unit version to version 1.1. • Corrected mistakes.
05	April 2018	<ul style="list-style-type: none"> • Made changes accompanying the addition of NX-series NX102 CPU Unit. • Corrected mistakes.

Sections in this Manual

1	Introduction to IO-Link Systems	10	Troubleshooting for IO-Link Systems	1	10
2	Part Names and Wiring	A	Appendices	2	A
3	Parameter Settings	I	Index	3	I
4	I/O Data			4	
5	Status and Software Switches Other Than for I/O data			5	
6	IO-Link System Communications			6	
7	Functions of IO-Link Master Units			7	
8	Applicable Support Software for IO-Link Systems			8	
9	Example of Operations for IO-Link Systems			9	

1

Introduction to IO-Link Systems

This section describes the features of IO-Link Systems and the system configuration in which an IO-Link System is used.

1-1	Introduction to and Features of IO-Link Systems	1-2
1-1-1	What Is IO-Link?	1-2
1-1-2	Overview of IO-Link System Configurations	1-2
1-1-3	Introduction to IO-Link Systems	1-4
1-1-4	Features of an IO-Link System	1-5
1-2	System Configurations	1-7
1-2-1	Types of Communications with the Controller	1-7
1-2-2	Controller Communications with EtherCAT	1-8
1-2-3	Controller Communications with EtherNet/IP	1-10
1-2-4	Controller Communications with NX Bus	1-10
1-3	Communications Specifications and IO-Link Devices	1-12
1-3-1	Communications Specifications	1-12
1-3-2	OMRON IO-Link Products	1-12
1-4	Communications for IO-Link Systems	1-14
1-4-1	Data in the Devices in an IO-Link System and How to Access It	1-14
1-4-2	Cyclic Communications	1-19
1-4-3	Message Communications	1-20
1-5	IO-Link Master Unit Functions	1-21
1-6	Startup Procedures	1-24
1-6-1	Controller Communications with EtherCAT	1-24
1-6-2	Controller Communications with EtherNet/IP	1-29
1-6-3	Controller Communications with NX Bus	1-29

1-1 Introduction to and Features of IO-Link Systems

This section gives an introduction to IO-Link Systems and describes their features.

1-1-1 What Is IO-Link?

IO-Link is a standard interface for 1:1 (point-to-point) connections with sensors, actuators, or other devices as defined in international standard IEC 61131-9.

Devices that previously could not exchange digital I/O signals can now exchange information such as detected amounts.

Data exchange is possible using the following two types of communications.

- Cyclic communications to exchange specified data in a specific cycle with devices
- Message communications to access user-specified data in devices when required

You can also connect non-IO-Link sensors or actuators that support only digital input signals or only digital output signals.

1-1-2 Overview of IO-Link System Configurations

An IO-Link System consists of the following elements.

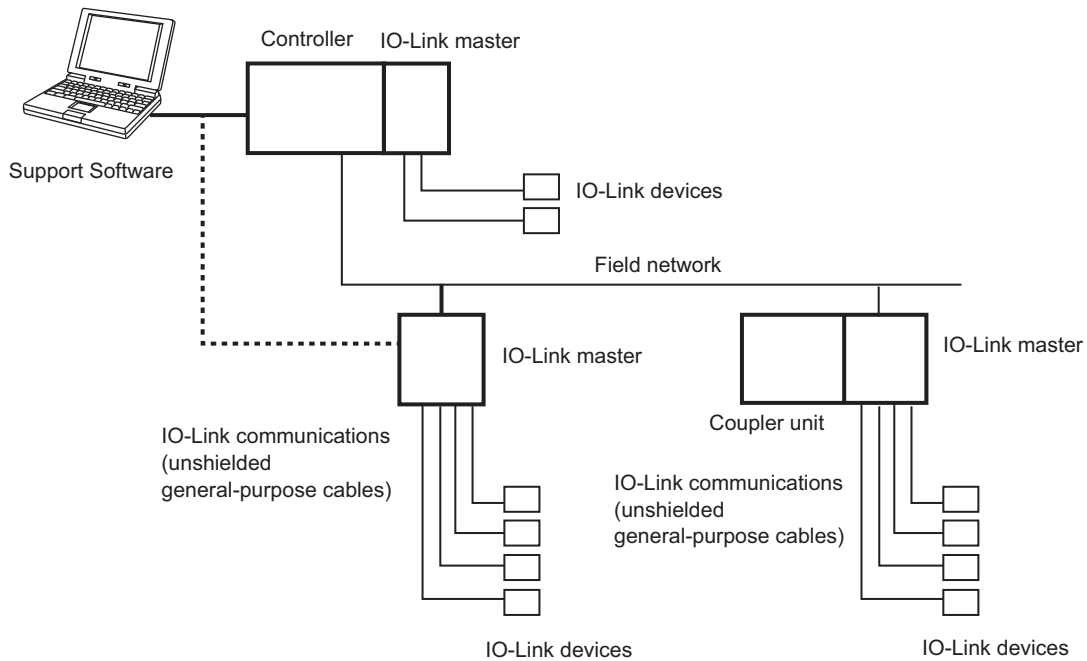

● Configuration Elements in an IO-Link System

The configuration elements of an IO-Link System that uses an OMRON IO-Link Master Unit are described below.

Configuration element	Description
Controller	<p>The controller is configured by the CPU Unit and communications master. It exchanges I/O data with the IO-Link Master Unit, and executes the user program.</p> <p>For details on the method of connecting the I/O-Link Master and the controller, refer to the contents of the IO-Link Master Unit.</p>
IO-Link master	<p>The IO-Link master performs IO-Link communications with IO-Link devices. There are two types of IO-Link Master Units: a terminal-type GX-type and a building-block NX-type.</p> <ul style="list-style-type: none"> • The GX-type can communicate with the controller via EtherCAT. • The NX-type can communicate with the controller via the NX bus of a connected CPU Unit or via the communications network of a connected Communications Coupler Unit. The communications types of the Communications Coupler Unit include EtherCAT and EtherNet/IP. <p>For details on the CPU Unit that an NX-type can connect to, refer to the user's manual of the CPU Unit.</p> <p>For details on the Communications Coupler Unit that an NX-type can connect to, refer to the user's manual of the Communications Coupler Unit.</p>
IO-Link devices	<p>The IO-Link devices are sensors, actuators, or other devices that use the IO-Link System to communicate with the IO-Link Master Unit.</p> <p>Examples: Photoelectric Sensor or Proximity Sensor</p>
Unshielded general-purpose cables	<p>Both three-wire cables for the IO-Link interface and four-wire cables that also support digital inputs for pin 2 are available. 20 m max.</p>
Support Software	<ul style="list-style-type: none"> • IO-Link Master Unit Configuration Tool^{*1} The following Support Software to configure the IO-Link Master Unit. Sysmac Studio, NX-IO Configurator • IO-Link Device Configuration Tool^{*1} The Support Software to configure the IO-Link devices. CX-ConfiguratorFDT

*1. For details, refer to *Applicable Support Software* on page 1-8 for each configuration in 1-2-1 *Types of Communications with the Controller* on page 1-7.

1-1-3 Introduction to IO-Link Systems

The IO-Link Master Unit is connected 1:1 to an IO-Link device with a standard cable. The IO-Link master has multiple ports to connect to multiple IO-Link devices.

Also, the IO-Link Master Unit connects as a slave of the controller through communications networks such as EtherCAT. It can also connect directly to the NX bus of the controller.

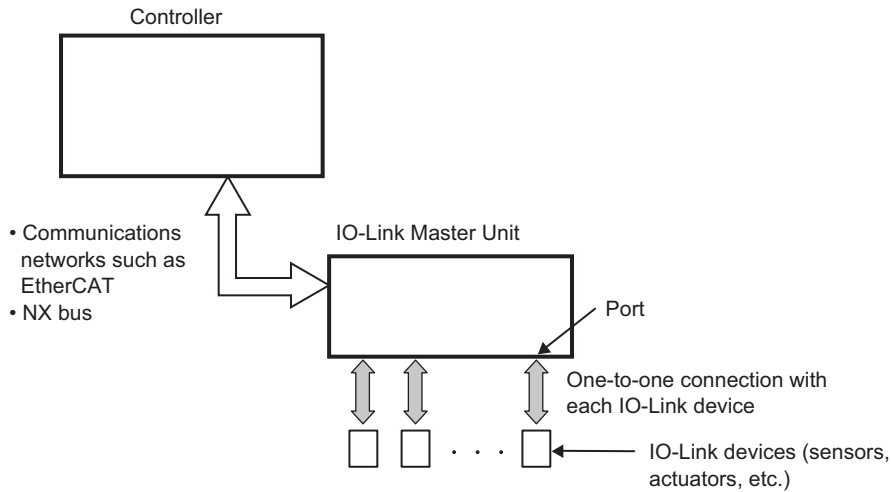

● Types of Data Exchange with the Ports on an OMRON IO-Link Master Unit

The OMRON IO-Link Master Units can perform the following types of data exchange with the IO-Link devices through the ports.

Types of data exchange through the ports	Function	
IO-Link communications	Cyclic communications	Cyclic communications are used to share specific parts of memory between the IO-Link Master Unit and the IO-Link devices on a specific cycle. Cyclic communications are the same as the process data (PD) communications with the IO-Link protocol.
	Message communications	Message communications are used to access user-specified data in the IO-Link devices from the controller through the IO-Link Master Unit when necessary. Message communications are the same as the on-request data (OD) communications in the IO-Link protocol.
Digital inputs for pin 2 ^{*1}	You can use pin 2 to input digital signals in parallel with IO-Link communications when faster response than for IO-Link communications is necessary.	
Digital signal inputs	These inputs can be connected to non-IO-Link sensors. The IO-Link Master Unit functions as a digital input terminal or unit.	
Digital signal outputs	These outputs can be connected to non-IO-Link actuators. The IO-Link Master Unit functions as a digital output terminal or unit.	

*1. This is possible only for IO-Link devices that support digital inputs for pin 2.

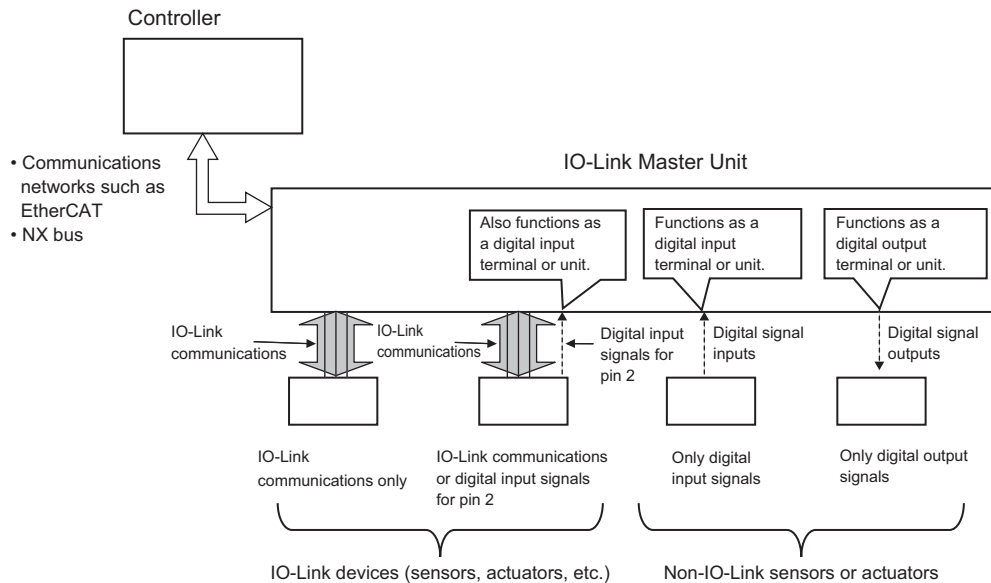

The above types of data exchange are set in advance with the communications mode parameters in the OMRON IO-Link Master Unit. Refer to 1-4 Communications for IO-Link Systems on page 1-14 and 2-2-1 IO-Link Mode on page 2-5.

1-1-4 Features of an IO-Link System

Reading Both ON/OFF Information and Various Other Types of Information

- (a) The controller can cyclically read the following ON/OFF information.
 - Input signals and status from IO-Link devices*1
 - Disconnections, short-circuits, I/O power ON status, etc., between the IO-Link master and devices
- (b) Because an IO-Link System can cyclically read analog data such as the amount of incident light in addition to ON/OFF information, it can be used for predictive maintenance based on detection of such things as decreases in the amount of light.

*1. Examples for Photoelectric Sensors: Instability detection and sensor errors.

Reading and Writing User-specified Data in the IO-Link Devices from the Controller When Necessary

You can read and write user-specified data in the IO-Link devices from the controller by executing communications instructions in the controller when necessary.

This lets you change IO-Link device parameter settings, monitor status, and perform operations.

Inputting Digital Signals from Sensors and Other IO-Link Devices during IO-Link Communications

For OMRON's IO-Link Master Units, you can use digital inputs for pin 2 for high-speed input of digital input signals during IO-Link communications.

Combining IO-Link Devices with General-purpose Sensors or Actuators

- You can connect a combination of IO-Link devices and non-IO-Link devices, such as general-purpose sensors or actuators, to the same IO-Link Master Unit. This allows a single master to function as an IO-Link communications terminal, a digital input terminal, and a digital output terminal.
- When you change from an existing system to an IO-Link System, there is no need to replace the cables of existing general-purpose sensors and actuators.

Checking for Incorrect Connections of IO-Link Devices When IO-Link Communications Start

You can register in advance ID information on the IO-Link devices that should connect to the ports of the IO-Link Master Unit to enable verifying the connections of the IO-Link devices when IO-Link communications start. This lets you reduce commissioning and maintenance work.

Easy Replacement of IO-Link Devices

For OMRON's IO-Link Master Units, you can back up parameter settings of the IO-Link devices in the IO-Link Master Unit.

When you replace IO-Link devices, you can automatically restore the backup parameters in the new IO-Link devices.

This eliminates the need for software tools when replacing IO-Link devices.

Easy Isolation of Error Locations from the Controller

Before, it was not possible to determine based on ON/OFF signals alone whether signals from sensors or actuators that remained OFF indicated an OFF status or an error. With IO-Link devices, sensors and other devices can report errors to the master.

This lets you easily detect sensor errors from the controller.

Checking the Quality of IO-Link Communications

OMRON's IO-Link Master Units record the total number of lost frames in cyclic communications. You can use this value to check the status of IO-Link communications.

1-2 System Configurations

This section describes IO-Link system configurations when you use an OMRON IO-Link Master Unit.

1-2-1 Types of Communications with the Controller

You can use an OMRON IO-Link Master Unit by communicating with the following controller.

Communications with the controller	Controller
EtherCAT	NJ/NX-series CPU Unit or NY-series Industrial PC
	Host controller from another company
EtherNet/IP	NJ/NX-series CPU Unit, NY-series Industrial PC, CJ/CP/CS-series PLC, or controller from another company
NX bus	NX-series CPU Unit

1-2-2 Controller Communications with EtherCAT

The controller can be an NJ/NX-series CPU Unit, an NY-series Industrial PC, or a controller from another company.

Using an NJ/NX-series CPU Unit or NY-series Industrial PC as the Controller

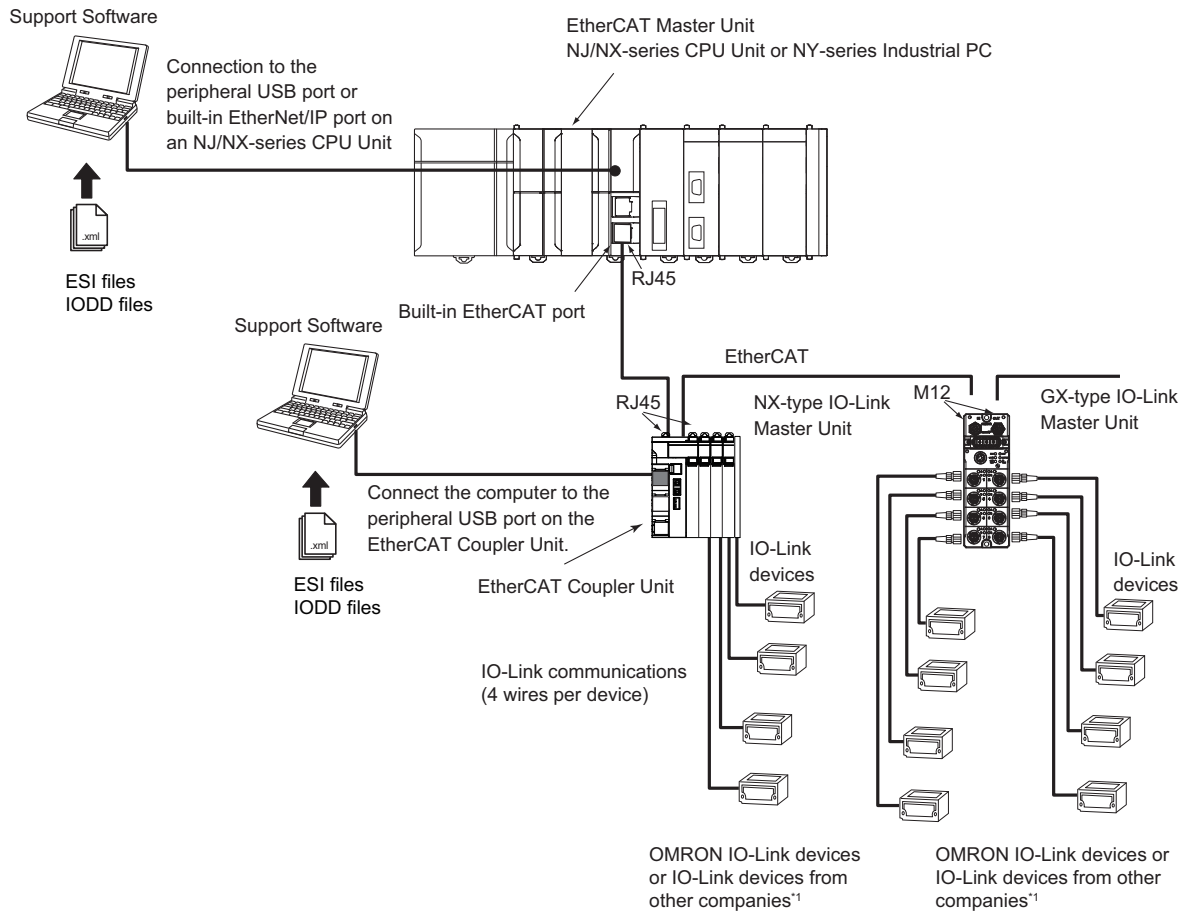

*1. You can also connect a combination of general-purpose sensors and other devices.

● Applicable Support Software

IO-Link Master Unit type	Applicable Support Software		
	I/O allocation settings (NX) PDO allocation settings (GX)	IO-Link Master Unit settings ^{*1}	Setting and monitoring the IO-Link devices
NX	Sysmac Studio	Sysmac Studio	CX-ConfiguratorFDT ^{*2}
GX	Sysmac Studio	Sysmac Studio	CX-ConfiguratorFDT ^{*2}

*1. The IO-Link device connection configuration information settings are included in the IO-Link Master Unit settings.

*2. CX-ConfiguratorFDT version 2.2 or higher is required.

● Communications

Yes: Can be used. No: Cannot be used.

Applicable master	Cyclic communications	Message communications
NX-type IO-Link Master Unit	Yes	Yes
GX-type IO-Link Master Unit	Yes	Yes

● Communications Methods

- Cyclic communications

Target master and device		Required action
NX-type IO-Link Master Unit	OMRON IO-Link devices or IO-Link devices from other companies	<ul style="list-style-type: none"> • I/O allocation settings from the Sysmac Studio are not necessary for an IO-Link device with an IO-Link input data size of 2 bytes or less, and an IO-Link output data size of 2 bytes or less. • I/O allocation from the Sysmac Studio is necessary for all other IO-Link devices.
GX-type IO-Link Master Unit		

- Message communications

Target master or device	Communications instructions used	Required action
NX-type IO-Link Master Unit	Use the following communications instructions: <ul style="list-style-type: none"> • NX_WriteObj (Write NX Unit Object) instruction • NX_ReadObj (Read NX Unit Object) instruction 	You must make EtherCAT configuration settings and slave terminal configuration settings from the Sysmac Studio.
GX-type IO-Link Master Unit	Use the following communications instructions: <ul style="list-style-type: none"> • EC_CoESDOWrite (Write EtherCAT CoE SDO) instruction • EC_CoESDORead (Read EtherCAT CoE SDO) instruction 	You must make EtherCAT configuration settings from the Sysmac Studio.
I/O device connected to an NX-type IO-Link Master Unit	Use the following communications instructions: <ul style="list-style-type: none"> • IOL_WriteObj (Write Device Object) instruction^{*1} 	You must make EtherCAT configuration settings and slave terminal configuration settings from the Sysmac Studio.
I/O device connected to an GX-type IO-Link Master Unit	<ul style="list-style-type: none"> • IOL_ReadObj (Read Device Object) instruction^{*1} 	You must make EtherCAT configuration settings from the Sysmac Studio.

*1. Unit version 1.12 or later of the NJ/NX-series CPU Unit is required to use these instructions.

Using a Controller from Another Company

For a system configuration that uses EtherCAT communications with a controller from another company, refer to *A-1-1 Using a Controller from Another Company with EtherCAT Communications* on page A-2.

1-2-3 Controller Communications with EtherNet/IP

The controller can be an NJ/NX-series CPU Unit, an NY-series Industrial PC, a CJ/CP/CS-series PLC, or a controller from another company.

Using an NJ/NX-series CPU Unit or NY-series Industrial PC as the Controller

When you use an NJ/NX-series CPU Unit or NY-series Industrial PC, refer to *A-1-2 Using an NJ/NX-series CPU Unit or NY-series Industrial PC with EtherNet/IP Communications* on page A-10.

Using a CJ/CP/CS-series PLC or a Controller from Another Company

When you use a CJ/CP/CS-series PLC or controller from another company, refer to *A-1-3 Using a CJ/CP/CS-series PLC or a Controller from Another Company with EtherNet/IP Communications* on page A-16.

1-2-4 Controller Communications with NX Bus

NX bus communications can be used when the Controller is an NX-series CPU Unit. In this case, only the NX-type IO-Link Master Unit can be used.

For whether an NX Unit can be connected to the CPU Unit, refer to the user's manual for the CPU Unit.

Using an NX-series CPU Unit as the Controller

The following figure shows a system configuration when the IO-Link Master Unit is connected to an NX-series NX1P2 CPU Unit.

Refer to the user's manual for the connected CPU Unit for system configurations and corresponding versions of Support Software if the connected CPU Unit is not an NX1P2 CPU Unit.

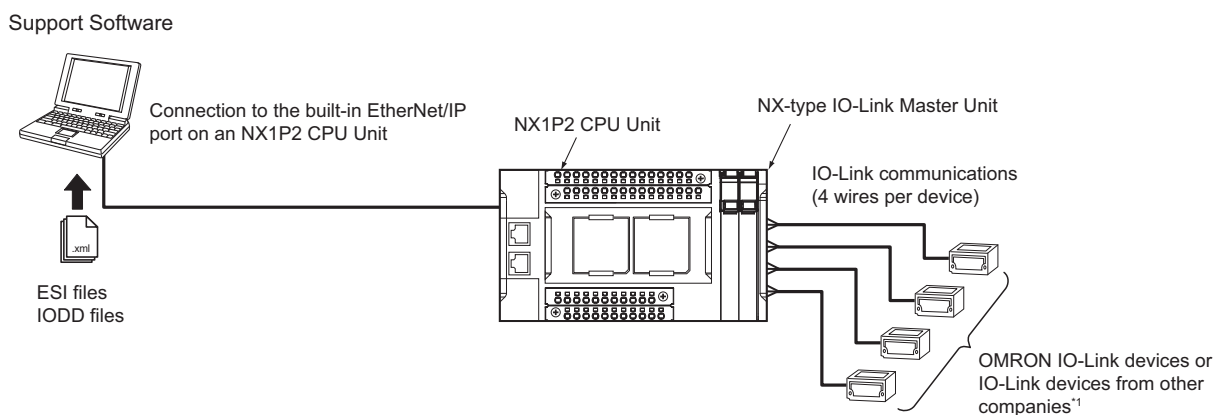

*1. You can also connect a combination of general-purpose sensors and other devices.

● Applicable Support Software

IO-Link Master Unit type	Applicable Support Software		
	I/O allocation settings	IO-Link Master Unit settings ^{*1}	Setting and monitoring the connected IO-Link devices
NX	Sysmac Studio ^{*2}	Sysmac Studio ^{*2}	CX-ConfiguratorFDT ^{*3}

*1. The IO-Link device connection configuration information settings are included in the IO-Link Master Unit settings.

*2. Sysmac Studio version 1.17 or higher is required.

*3. CX-ConfiguratorFDT version 2.3 or higher is required.

● Communications

Yes: Can be used. No: Cannot be used.

Applicable master	Cyclic communications	Message communications
NX-type IO-Link Master Unit	Yes	Yes

● Communications Methods

- Cyclic Communications

Target master and devices		Required action
NX-type IO-Link Master Unit	OMRON IO-Link devices or IO-Link devices from other companies	<ul style="list-style-type: none"> • NX Unit settings from the Sysmac Studio are not necessary for an IO-Link device with an IO-Link input data size of 2 bytes or less and an IO-Link output data size of 2 bytes or less. • I/O allocation from the Sysmac Studio is necessary for all other IO-Link devices.

- Message Communications

Target master or device	Communications instructions used	Required action
NX-type IO-Link Master Unit	Use the following communications instructions: <ul style="list-style-type: none"> • NX_WriteObj (Write NX Unit Object) instruction • NX_ReadObj (Read NX Unit Object) instruction 	You must make EtherCAT configuration settings and Slave Terminal configuration settings from the Sysmac Studio.
I/O device connected to an NX-type IO-Link Master Unit	Use the following communications instructions: <ul style="list-style-type: none"> • IOL_WriteObj (Write Device Object) instruction • IOL_ReadObj (Read Device Object) instruction 	

1-3 Communications Specifications and IO-Link Devices

This section provides the IO-Link *communications specifications* and gives an overview of OMRON's IO-Link devices and their basic functions.

1-3-1 Communications Specifications

Item	Specification
Communications protocol	IO-Link protocol
Baud rate	COM1 (4.8 kbps), COM2 (38.4 kbps), or COM3 (230.4 kbps)
Topology	1:1
Communications media	Unshielded cable
Communications distance	20 m max.
Compliant standards	<ul style="list-style-type: none"> IO-Link Interface and System Specification Version 1.1.2^{*1} IO-Link Test Specification Version 1.1.2

*1. OMRON IO-Link products do not support the IO-Link preoperate state.

1-3-2 OMRON IO-Link Products

IO-Link Master Unit

Model	Type	Name	Number of ports	Port connection terminals	Environmental resistance
NX-ILM400	NX	NX-series IO-Link Master Unit	4	Screwless clamping terminal block	IP20
GX-ILM08C	GX	EtherCAT Slave IO-Link Master Unit	8	M12 connector (A-coding, female)	IP67

Refer to *NX-series IO-Link Master Unit User's Manual* (Cat. No. W567) and *GX-series EtherCAT Slave Unit User's Manual* (Cat. No. W488-E1-05 or later) for detailed specifications.

Applicable Support Software

Name	Description
Sysmac Studio Version 1.16 or higher	<p>The Sysmac Studio is used to assign I/O data and set parameters in the IO-Link Master Unit.</p> <p>When you use the Sysmac Studio to verify the IO-Link device configuration, you can also set the IO-Link device configuration.</p> <p>The Sysmac Studio is used to configure EtherCAT networks and slaves, and to perform programming, monitoring, and troubleshooting.</p>
NX-IO Configurator	This software is used to configure the Slave Terminals and perform troubleshooting when an EtherNet/IP Coupler Unit is used with a CJ/CP/CS-series PLC as the controller or with a controller from another company.
CX-ConfiguratorFDT Version 2.2 or higher	This software is used to set IO-Link device parameters and monitor I/O data (process data).

For details on the Support Software, refer to *Section 8 Applicable Support Software for IO-Link Systems*.

Applicable Device Definition Files

The device definition files that are required to use support software from another company are listed in the following table.

Device definition files	Description	Compatible models	Method to obtain the files
ESI (EtherCAT Slave Information) files	<p>These files contain the EtherCAT slave definitions.</p> <p>If you install Sysmac Studio version 1.16 or higher, the OMRON ESI files are installed automatically. If you use an EtherCAT master from another company, you must install the ESI files in the EtherCAT tool of that company.</p>	GX-ILM08C	Download the file from your OMRON website.
IODD (IO Device Description) files	<p>These files contain IO-Link device definitions.</p> <p>The IODD files for OMRON's IO-Link devices are automatically installed when you install CX-ConfiguratorFDT. If you use IO-Link devices from another company, you must install the IODD files for the IO-Link devices of that company in CX-ConfiguratorFDT.</p>	OMRON IO-Link devices or IO-Link devices from other companies	For OMRON's IO-Link devices, download the files from your OMRON website.

Peripheral Devices

For cable model numbers, refer to *A-2 Connected Device Specifications and Models* on page A-24.

1-4 Communications for IO-Link Systems

This section describes communications in an IO-Link System.

There are the following two types of communications in an IO-Link System

- Cyclic communications
- Message communications

1-4-1 Data in the Devices in an IO-Link System and How to Access It

An overview of the types of data in the devices in an IO-Link System and how to access that data is given below.

Data Type of Each Device

The data type of each device is as follows.

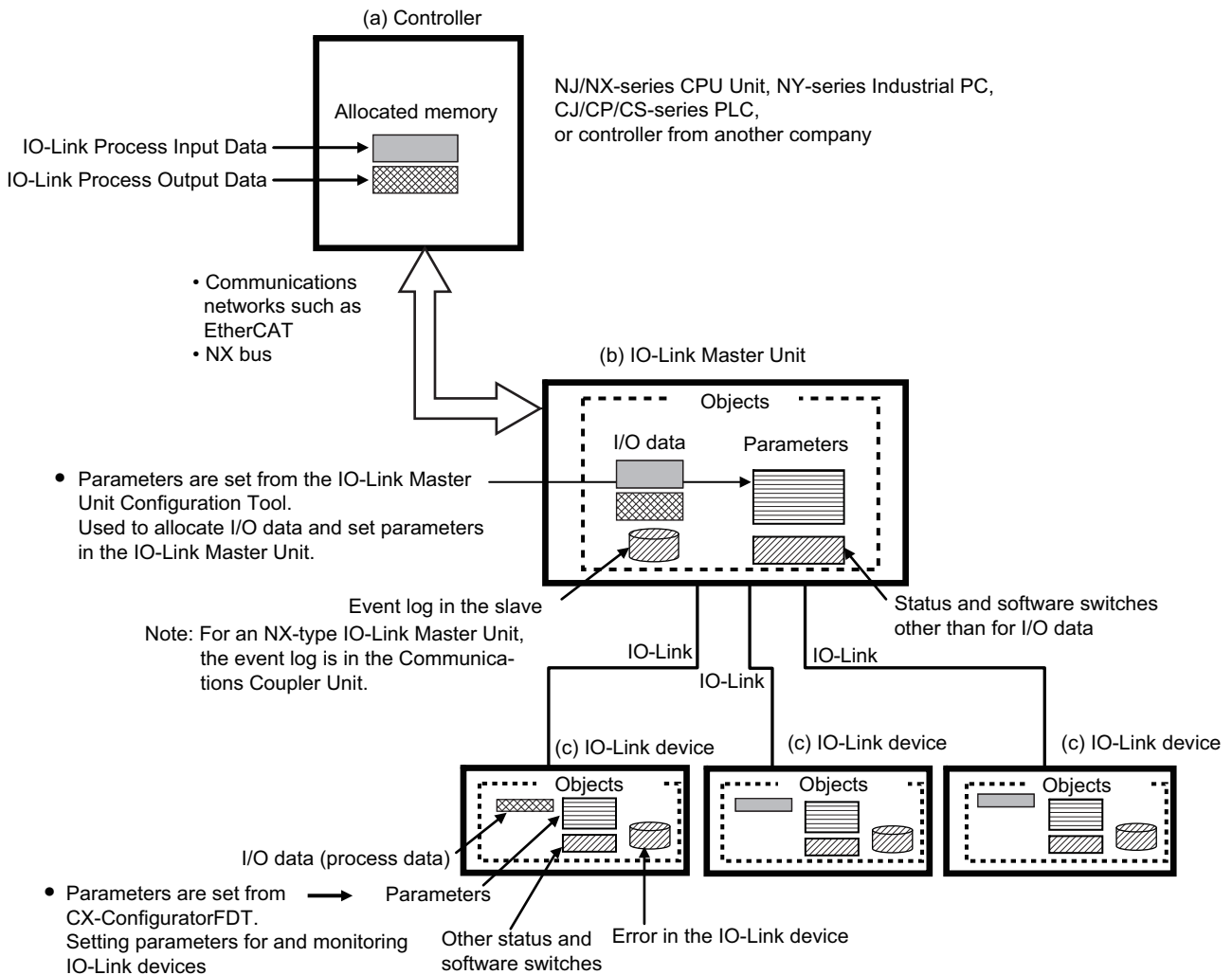

Device	Data type	Description	Examples
(a) Controller	Allocated memory	Memory allocated to I/O data in the IO-Link Master Unit	
(b) IO-Link Master Unit	I/O data* ¹	Target data in cyclic communications with the controller	Allocation of I/O data in devices connected to the IO-Link ports: <ul style="list-style-type: none"> • Process Input data from IO-Link devices, digital input data • Process Output data to IO-Link devices, digital output data • IO-Link Master Unit Status: Sysmac Error Status, Input Data Enabled Flags, and I/O Port Error Status
	Parameters	Settings that are set from the Support Software.	Communications modes, IO-Link Device Verification Setting, IO-Link Device Configuration Settings, Backup Setting, Restoration Setting, Load Rejection Output Setting, and Digital Input Filter Setting
	Status and software switches other than for I/O data	Target data in message communications except for parameters and I/O data	<ul style="list-style-type: none"> • Status: Lost frame*² and IO-Link device information • Software switches: Backup data clear designations
	Event log in the IO-Link Master Unit	Data that records the events that have occurred in the IO-Link Master Unit or the IO-Link devices	<ul style="list-style-type: none"> • Events detected by the IO-Link Master Unit*³ • IO-Link events received from IO-Link devices*⁴
(c) IO-Link device	I/O data	Target data in the cyclic communications with the IO-Link Master Unit	I/O data of IO-Link devices (process data): <ul style="list-style-type: none"> • Photoelectric sensors: Sensor output, unstable detection, amount of incident light, and errors • Proximity sensors: Sensor output, unstable detection, excessive proximity, amplitude, voltage, and sensor errors
	Parameters	Settings that are set from the Support Software.	<ul style="list-style-type: none"> • Photoelectric sensors: L-ON/D-ON mode selection, sensitivity level settings, etc. • Proximity sensors: Diagnostic output (excessive proximity), mode settings, etc.
	Status and software switches other than for I/O data	Target data in message communications, except for parameters	<ul style="list-style-type: none"> • Operating time • Stopping light emission or teaching for photoelectric sensors
	Errors of the IO-Link device	Data that records IO-Link device errors and warnings that have occurred in the IO-Link devices.	<ul style="list-style-type: none"> • Proximity sensor coil breaks • Destruction of light emission circuits in photoelectric sensors

*1. Accessing I/O data in the IO-Link Master Unit from the controller with communications instructions is not possible.

*2. This is the total number of IO-Link communications lost frames.

*3. These events include IO-Link communications errors, IO-Link power supply errors, and device configuration verification errors.

*4. These are called device events.

Data Access Methods for Each Device

● Controller Communications with EtherCAT

The following shows the data access methods of each device for controller communications with EtherCAT.

When accessing by message communications using SDO communications instructions from the controller to the IO-Link Master Unit connected to an EtherCAT Coupler Unit, EtherCAT Coupler Unit with unit version 1.5 or later is required.

Device	Data type	Communications methods	Data access method	
			NJ/NX-series CPU Unit or NY-series Industrial PC built-in EtherCAT port	Controller from another company
(a) Controller	Allocated memory	Cyclic communications	Specify an I/O port as the EtherCAT slave	Use the access method specified by the manufacturer
(b) IO-Link Master Unit	I/O data ^{*1}			
	Parameters	---	Set the following with the IO-Link Master Unit Configuration Tool.	Accessing data with SDO communications instructions from the controller ^{*3}
		Message communications	Accessing data with communications instructions from the controller ^{*2}	
	Status and software switches other than for I/O data	Message communications		
	Event log of the IO-Link Master Unit	---	Read the event log with the IO-Link Master Unit Configuration Tool	---
Message communications		Accessing data with communications instructions from the controller ^{*4*5}	Accessing data with SDO communications instructions from the controller ^{*4}	
(c) IO-Link devices	I/O data	Cyclic communications	Allocate I/O to the I/O data in the IO-Link Master Unit and then allocate I/O to the same I/O data in the controller.	
	Parameters	---	Set with CX-ConfiguratorFDT	Accessing data with SDO communications instructions from the controller ^{*3*7}
		Message communications	Accessing data with communications instructions from the controller ^{*6}	
	Status and software switches other than for I/O data	Message communications		
	Errors in the IO-Link device	---	Read errors with CX-ConfiguratorFDT	
Message communications		Accessing data with communications instructions from the controller ^{*6*8}	Accessing data with SDO communications instructions from the controller ^{*3*7*8}	

*1. The allocated I/O data in the IO-Link Master Unit cannot be accessed from the controller with communications instructions.

*2. Use the following communications instructions:
 NX-type IO-Link Master Unit: NX_WriteObj instruction or NX_ReadObj instruction
 GX-type IO-Link Master Unit: EC_CoESDOWrite instruction or EC_CoESDORead instruction

*3. For the NX-type IO-Link Master Unit, access the relevant NX objects of the IO-Link Master Unit through the CoE objects that are used to read and edit the Unit operation settings of an NX Unit of the EtherCAT Coupler Unit.
 For the GX-type IO-Link Master Unit, access the relevant CoE objects of the IO-Link Master Unit.

*4. For the NX-type IO-Link Master Unit, access the relevant CoE objects of the EtherCAT Coupler Unit.
 For the GX-type IO-Link Master Unit, access the relevant CoE objects.

*5. Use the EC_CoESDOWrite instruction or EC_CoESDORead instruction.

*6. Use the IOL_WriteObj instruction or IOL_ReadObj instruction.

- *7. For details on how to access the data of an IO-Link device, refer to A-3 *How to Access the IO-Link Devices with Message Communications* on page A-28.
- *8. Check the Detailed Device Status of the IO-Link device.

● **Controller Communications with EtherNet/IP**

The following shows the data access methods of each device for controller communications with EtherNet/IP.

When accessing by message communications to the IO-Link Master Unit, EtherNet/IP Coupler Unit with unit version 1.2 or later is required.

Device	Data type	Communications methods	Data access method		
			NJ/NX-series CPU Unit or NY-series Industrial PC built-in EtherNet/IP port	CJ/CP/CS-series PLC	Controller from another company
(a) Controller	Allocated memory	Cyclic communications	Accessing data from the controller:		
(b) IO-Link Master Unit	I/O data ^{*1}		• Tag data link settings		
(b) IO-Link Master Unit	Parameters	---	Set the Unit operation settings with the IO-Link Master Unit Configuration Tool		
		Message communications	Accessing data with communications instructions from the controller ^{*2*3}	Accessing data with communications instructions from the controller ^{*3*4}	Accessing data with explicit messages from the controller ^{*3}
	Status and software switches other than for I/O data	Message communications			
	Event log in the IO-Link Master Unit	---	Read the event log with the IO-Link Master Unit Configuration Tool		
		Message communications	Accessing data with communications instructions from the controller ^{*2*5}	Accessing data with communications instructions from the controller ^{*4*5}	Accessing data with explicit messages from the controller ^{*5}
(c) IO-Link device	I/O data	Cyclic communications	Allocate I/O to the I/O data in the IO-Link Master Unit and then allocate I/O to the same I/O data in the controller.		
	Parameters	---	Set with CX-ConfiguratorFDT		
		Message communications	Accessing data with communications instructions from the controller ^{*2*3*6}	Accessing data with the Smart FB from the controller ^{*7}	Accessing data with explicit messages from the controller ^{*3*6}
	Status and software switches other than for I/O data	Message communications			
	Errors in the IO-Link device	---	Read errors with CX-ConfiguratorFDT		
Message communications		Accessing data with communications instructions from the controller ^{*2*3*6*8}	Accessing data with the Smart FB from the controller ^{*7*8}	Accessing data with explicit messages from the controller ^{*3*6*8}	

- *1. The allocated I/O data in the IO-Link Master Unit cannot be accessed from the controller with communications instructions.
- *2. Use the CIPSend instruction or CIPUCMMSend instruction.
- *3. Use the CIP object Read NX object (33 hex) or Write NX object (34 hex) of the EtherNet/IP Coupler Unit to access the relevant NX objects of the IO-Link Master Unit.
- *4. Use the CMND instruction (FINS 2810).
- *5. Use the CIP object Get event log (3B hex) of the EtherNet/IP Coupler Unit to access the IO-Link Master Unit.
- *6. For details on how to access the data of an IO-Link device, refer to A-3 *How to Access the IO-Link Devices with Message Communications* on page A-28.
- *7. Use the _IOL003_ReadObjEip instruction or _IOL004_WriteObjEip instruction.
- *8. Check the Detailed Device Status of the IO-Link device.

● Controller Communications with NX Bus

The following shows the data access methods of each device for controller communications with the NX bus.

Device	Data type	Communications Methods	Data access method
			CPU Unit
(a) Controller	Allocated memory	Cyclic communications	Specify the I/O port
(b) IO-Link Master Unit	I/O data ^{*1}		
	Parameters	---	Set the Unit operation settings with Sysmac Studio.
		Message communications	Accessing data with communications instructions from the controller ^{*2}
	Status and software switches other than for I/O data	Message communications	
	Event log in the IO-Link Master Unit	---	Read the event log with the IO-Link Master Unit Configuration Tool
Message communications		---	
(c) IO-Link devices	I/O data	Cyclic communications	Allocate I/O to the I/O data in the IO-Link Master Unit and then allocate I/O to the same I/O data in the controller.
	Parameters	---	Set with CX-ConfiguratorFDT
		Message communications	Accessing data with communications instructions from the controller ^{*3}
	Status and software switches other than for I/O data	Message communications	
	Errors in the IO-Link device	---	Read errors with CX-ConfiguratorFDT
Message communications		Accessing data with communications instructions from the controller ^{*3*4}	

*1. The allocated I/O data in the IO-Link Master Unit cannot be accessed from the controller with communications instructions.

*2. Use the NX_WriteObj instruction or NX_ReadObj instruction.

*3. Use the IOL_WriteObj instruction or IOL_ReadObj instruction.

*4. Check the Detailed Device Status of the IO-Link device.

1-4-2 Cyclic Communications

An IO-Link System performs various cyclic communications as shown in the following figure between the controller and the IO-Link Master Unit, and between the IO-Link Master Unit and the IO-Link devices.

Refer to 6-2 *Cyclic Communications* on page 6-5 for details.

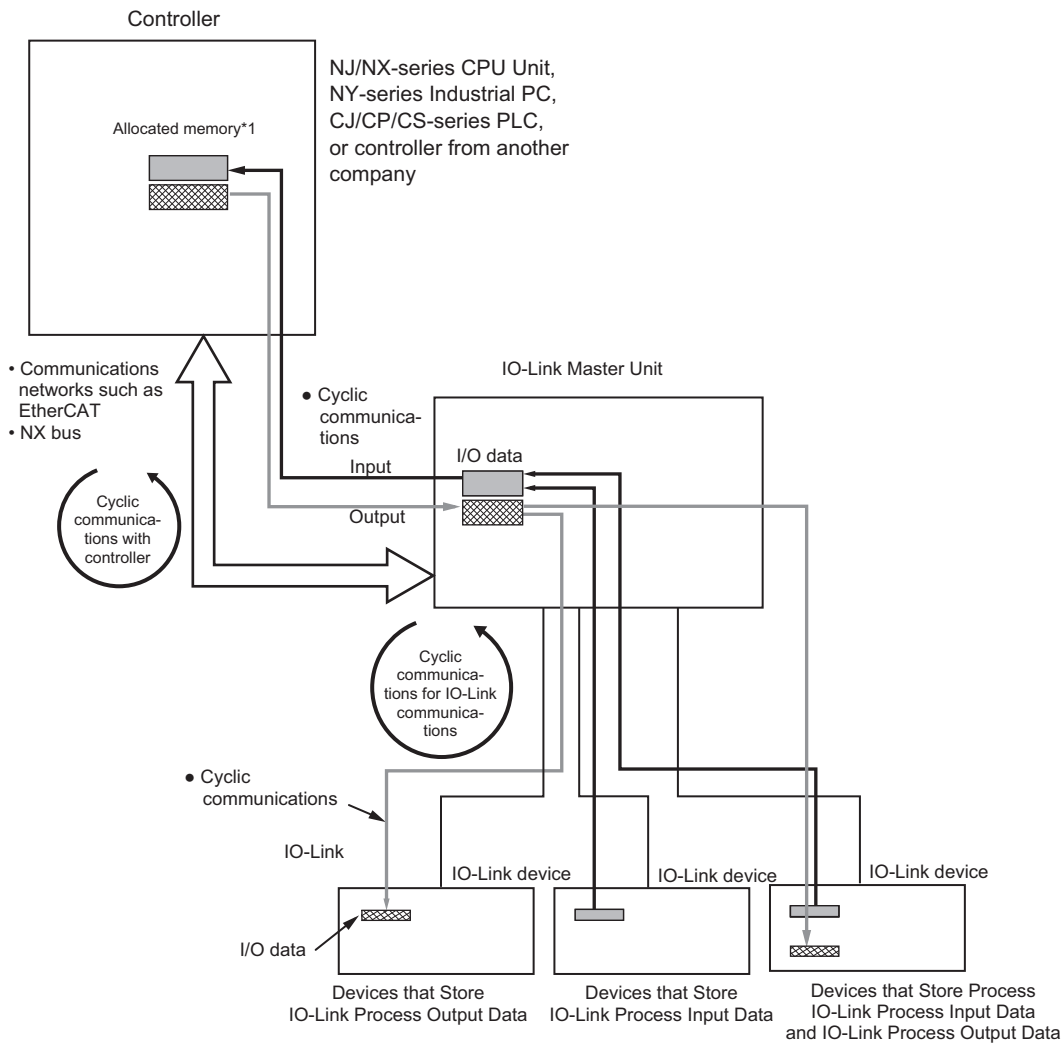

*1. The method to access the Units from the allocated memory or user program depends on the system configuration that is connected.

1-4-3 Message Communications

In an IO-Link System, communications instructions can be executed in the controller to send messages to the IO-Link Master Unit and the IO-Link devices.

Refer to 6-3 *Message Communications* on page 6-8 for details.

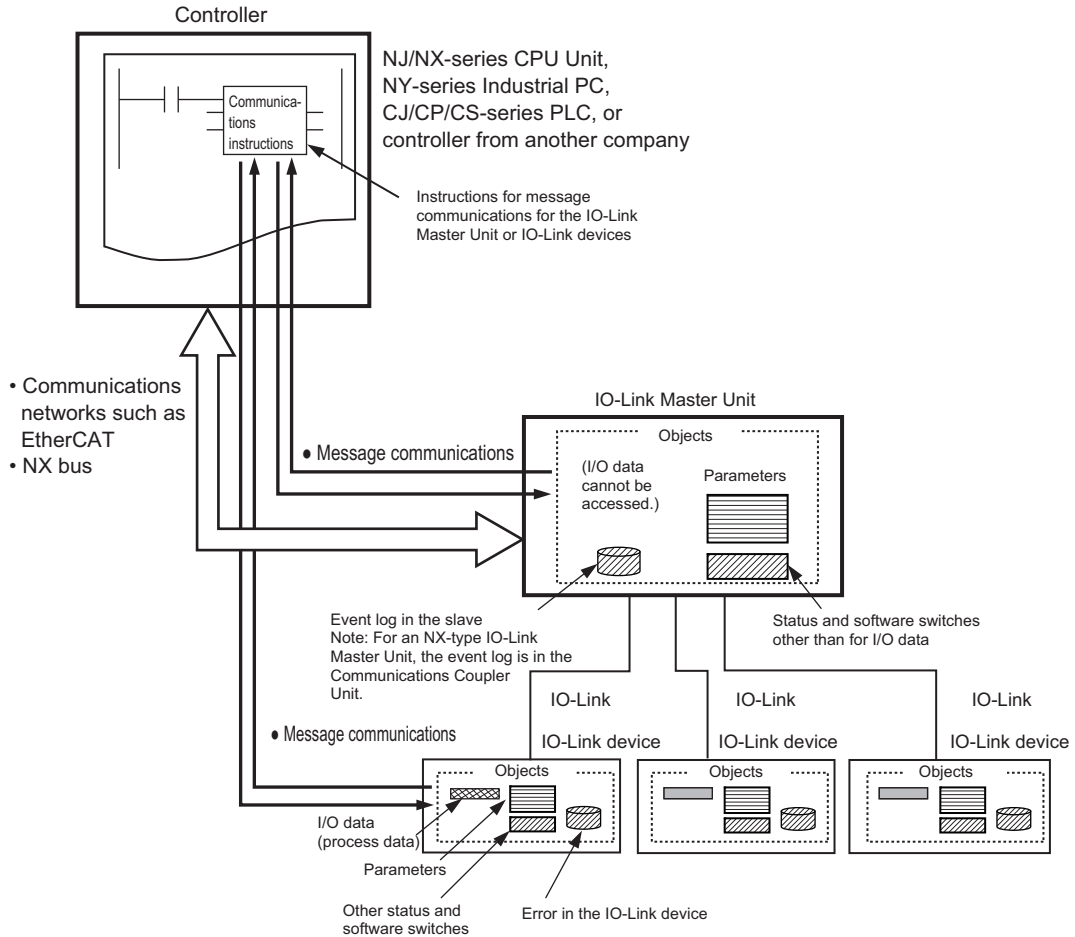

1-5 IO-Link Master Unit Functions

This section provides an overview of the functions of the IO-Link Master Unit.

Function		Description	Reference
Communica- tions	Cyclic communi- cations	I/O data (process data) in the IO-Link devices is cyclically exchanged with the IO-Link Master Unit as the IO-Link communications master. At the same time, this data and the status of the IO-Link Master Unit are cyclically exchanged with the controller, with the IO-Link Master Unit operating as a slave of the controller. Cyclic communications can be used to check the amount of detection performance deterioration in devices, and to check changes in usage conditions, such as the amount of incident light for photoelectric sensors, stability detection margins, and excessive proximity for proximity sensors.	<i>1-4-2 Cyclic Communica- tions</i> on page 1-19 <i>4-1 Outline of I/O Data</i> on page 4-2 <i>6-2 Cyclic Communica- tions</i> on page 6-5
	Message communi- cations	The controller can send messages (com- mands) to the IO-Link Master Unit and receive the response from the IO-Link Master Unit. The IO-Link Master Unit can also function as a gateway to send messages (commands and responses) between the controller and the IO-Link devices. During operation, you can change and adjust device parameters, such as threshold settings, tuning execution, and ON-delay time changes, from a program. Or, during operation, you can check the internal status, such as the operating times of devices.	<i>1-4-3 Message Communi- cations</i> on page 1-20 <i>6-3 Message Communica- tions</i> on page 6-8
Communications mode settings		You can select any of the following modes for each port: IO-Link Mode, SIO (DI) Mode, SIO (DO) Mode, and Disable Port. This allows you to combine IO-Link communications and digital I/O in a single terminal or unit.	<i>7-1 Communications Mode Settings</i> on page 7-2
Digital inputs for pin 2		In IO-Link Mode, you can perform digital input with pin 2 while performing IO-Link communi- cations.	
Automatic baud rate setting for IO-Link communications		The IO-Link Master Unit automatically matches the specific baud rates (COM1, COM2, or COM3) of the IO-Link devices to communicate with the IO-Link devices. Therefore, it is not necessary to set the baud rate of the connected device for each port.	<i>1-3-1 Communications Specifications</i> on page 1-12
Connected device verification		This function is used to verify the configuration of IO-Link devices that are connected to the IO-Link Master Unit against the registered IO-Link Device Configuration Settings when the power supply is turned ON. The user can enable or disable connected device verification.	<i>7-2 Connected Device Verification</i> on page 7-6

Function	Description	Reference
IO-Link communications error detection	This function detects I/O cable breaks, disconnections from IO-Link device ports, error-level device events, device configuration verification errors, and IO-Link device malfunctions.	4-1-2 <i>Type of I/O Data</i> on page 4-2
Detection of short-circuits in I/O cables	This function detects short-circuits in I/O cables.	
Notification of input data validity	The controller can use the Input Data Enabled Flags to determine whether the IO-Link process input data for IO-Link communications is valid.	
Load rejection for controller communications errors	This function turns OFF outputs from the IO-Link Master Unit when an error occurs in communications with the controller in IO-Link Mode or in an SIO mode. This prevents output operations with incorrect values when a communications error occurs.	7-3 <i>Load Rejection for Controller Communications Errors</i> on page 7-9
IO-Link total communications lost frames	This function lets you read the total number of IO-Link communications lost frames using communications instructions sent to the IO-Link Master Unit. You can use this function to determine communications status as affected by I/O cable noise or other factors.	7-4 <i>IO-Link Total Communications Lost Frames</i> on page 7-11
Digital input filter	You can remove the chattering and noise of the input signal for digital inputs in SIO (DI) Mode or for digital inputs for pin 2 in IO-Link Mode. When the input data changes without stabilization of the state of the contact point due to chattering and noise, this function prevents changes in data and stabilizes it.	7-5 <i>Digital Input Filter</i> on page 7-13
Digital input collection ^{*1}	In IO-Link Mode, this function reflects the specified bit data in the input data from the IO-Link device on the digital input data of the IO-Link Master Unit. As a result, the bit data in the input data from the IO-Link device can be aggregated into the digital input data of the IO-Link Master Unit. One bit for each IO-Link port can be aggregated. This function cannot be used in SIO (DI) Mode and SIO (DO) Mode. If you are using this function, you cannot perform digital inputs for pin 2.	7-7 <i>Digital Input Collection</i> on page 7-25
Backup and restoration of parameter settings in IO-Link devices	This function is used to back up parameter settings in IO-Link devices in the IO-Link Master Unit or restore them to IO-Link devices. This eliminates the need to set parameters again after replacing an IO-Link device.	7-6 <i>Backup and Restoration of Parameter Settings in IO-Link Devices</i> on page 7-14
Event log	This function records events, such as errors and status changes, that occur in the IO-Link Master Unit and IO-Link devices.	10-2 <i>Checking for Errors and Troubleshooting with Tools</i> on page 10-18

*1. The IO-Link Master Unit with unit version 1.1 or later is required to use this function.

The following table shows whether or not functions can be used according to the IO-Link Master Unit type and connection conditions.

Yes: Can be used. No: Cannot be used.

Function name		NX-type IO-Link Master Unit			GX-type IO-Link Master Unit
		Connected to EtherNet/IP Coupler Unit	Connected to EtherNet/IP Coupler Unit	Connected to CPU Unit	---
Communications	Cyclic communications	Yes	Yes	Yes	Yes
	Message communications	Yes	Yes ^{*1}	Yes	Yes
Communications mode settings		Yes	Yes	Yes	Yes
Digital inputs for pin 2					
Automatic baud rate setting for IO-Link communications		Yes	Yes	Yes	Yes
Connected device verification		Yes	Yes	Yes	Yes
IO-Link communications error detection		Yes	Yes	Yes	Yes
Detection of short-circuits in I/O cables		Yes	Yes	Yes	Yes
Notification of input data validity		Yes	Yes	Yes	Yes
Load rejection for controller communications errors		Yes	Yes	Yes	Yes
IO-Link total communications lost frames		Yes	Yes	Yes	Yes
Digital input filter		Yes	Yes	Yes	Yes
Backup and restoration of parameter settings in IO-Link devices		Yes	Yes	Yes	Yes
Digital input collection ^{*2}		Yes	Yes	Yes	Yes
Event log		Yes	Yes	Yes	Yes

*1. The EtherNet/IP Coupler Unit with unit version 1.2 or later is required to use this function.

*2. The IO-Link Master Unit with unit version 1.1 or later is required to use this function.

1-6 Startup Procedures

The startup procedures for an IO-Link System are given below.

1-6-1 Controller Communications with EtherCAT

The startup procedures are as follows when the controller is an NJ/NX-series CPU Unit or NY-series Industrial PC.

For details on the basic operating procedures when using a controller from another company, refer to *A-1-1 Using a Controller from Another Company with EtherCAT Communications* on page A-2.

Overall Procedure

Procedure	Reference
1. Mounting and Hardware Settings	<ul style="list-style-type: none"> User's manual of the IO-Link Master Unit User's manuals of the IO-Link devices
2. EtherCAT Communications Cable Wiring and IO-Link Port Wiring	<ul style="list-style-type: none"> <i>NJ/NX-series CPU Unit Built-in EtherCAT Port User's Manual</i> (Cat. No. W505) <i>NY-series IPC Machine Controller Industrial Panel PC / Industrial Box PC Built-in EtherCAT Port User's Manual</i> (Cat. No. W562) <i>Section 2 Part Names and Wiring</i>, IO-Link master user's manuals, and IO-Link device user's manuals
3. Creating the EtherCAT Network Configuration	<ul style="list-style-type: none"> <i>NJ/NX-series CPU Unit Built-in EtherCAT Port User's Manual</i> (Cat. No. W505) <i>NY-series IPC Machine Controller Industrial Panel PC / Industrial Box PC Built-in EtherCAT Port User's Manual</i> (Cat. No. W562) <i>8-2 Sysmac Studio Procedures</i> on page 8-4 and <i>Sysmac Studio Version 1 Operation Manual</i> (Cat. No. W504)
4. IO-Link Master Unit Settings (Parameter Settings and I/O Allocation Settings)	<ul style="list-style-type: none"> <i>Section 3 Parameter Settings</i> <i>8-2-2 Setting Parameters in the IO-Link Master Unit</i> on page 8-7 <i>Section 4 I/O Data</i> <i>8-2-3 Changing I/O Data Sizes in the IO-Link Master Unit</i> on page 8-8
5. Programming	<ul style="list-style-type: none"> <i>NJ/NX-series CPU Unit Software User's Manual</i> (Cat. No. W501) <i>NY-series IPC Machine Controller Industrial Panel PC / Industrial Box PC Software User's Manual</i> (Cat. No. W558) <i>Section 6 IO-Link System Communications</i> <i>Section 4 I/O Data</i> <i>Section 5 Status and Software Switches Other Than for I/O Data</i> <i>NJ/NX-series Instructions Reference Manual</i> (Cat. No. W502) <i>NY-series Instructions Reference Manual</i> (Cat. No. W560)

6. Turning ON the Power Supply and Going Online with the Support Software	<ul style="list-style-type: none"> • 2-1 Part Names and Functions on page 2-2 • 6-1 Types and Startup of Communications for IO-Link Systems on page 6-2 • Sysmac Studio Version 1 Operation Manual (Cat. No. W504)
7. Downloading the Network Configuration Information and User Program to the CPU Unit or Industrial PC	<ul style="list-style-type: none"> • Sysmac Studio Version 1 Operation Manual (Cat. No. W504)
8. Parameter Settings for IO-Link Devices (as Required)	<ul style="list-style-type: none"> • 8-4 CX-ConfiguratorFDT Procedures on page 8-14
9. Downloading Parameter Settings to IO-Link Devices (as Required)	<ul style="list-style-type: none"> • 8-4 CX-ConfiguratorFDT Procedures on page 8-14
10. Checking the Indicators on the IO-Link Master Unit and the IO-Link Devices	<ul style="list-style-type: none"> • 10-3 Backing Up Settings and Replacing Units on page 10-49
11. Checking the Error Status of the IO-Link Master Unit and the IO-Link Devices	

Procedure Details

The following gives the procedure details for each type of IO-Link Master Unit.

● Using a GX-type IO-Link Master Unit

Procedure	Description	Sysmac Studio operation	CX-ConfiguratorFDT operation
1. Mounting and Hardware Settings	Setting node addresses	---	---
↓			
2. EtherCAT Communications Cable Wiring and IO-Link Port Wiring	---	---	---
↓			
3. Registering the IO-Link Master Unit in the EtherCAT Network Configuration	Register the GX-type IO-Link Master Unit in the EtherCAT network configuration.	Drag the IO-Link Master Unit under the master on the EtherCAT Configuration Edit Tab Page.	---
↓			
4. IO-Link Master Unit Settings (Parameter Settings and I/O Allocation Settings)	Set the parameters for the GX-type IO-Link Master Unit and make the EtherCAT I/O allocation settings for the I/O data.	Select the IO-Link Master Unit in the EtherCAT Configuration Edit Tab Page and set the following.	---
Parameter Settings	The parameters include the communications mode and IO-Link Device Configuration Settings* ¹ for each port.	Edit Backup Parameter Settings Button	---
PDO Mapping (Allocation of I/O Data)	Add PDO entries for the connected IO-Link devices to the default PDO mapping.* ²	Edit PDO Map Settings Button	---
↓			

Procedure	Description	Sysmac Studio operation	CX-ConfiguratorFDT operation
5. Programming			
Cyclic Communications	In the user program, specify the device variables allocated to the I/O ports that are equivalent to the I/O data of the IO-Link Master Unit. Use the Input Data Enabled Flags as input conditions.	Create the programs with POUs under Programming .	---
Message Communications	Program communications instructions for the objects in the IO-Link Master Unit and the IO-Link devices.	Create the programs with POUs under Programming .	---
↓			
6. Turning ON Power and Going Online from the Sysmac Studio	Turn ON the power supply to the entire system and connect the Sysmac Studio.	Select Online under Controller to go online.	---
↓			
7. Downloading the Network Configuration Information and User Program to the CPU Unit or Industrial PC		Select Synchronization - Transfer To Controller under Controller to download the network configuration information and user program.	---
↓			
8. Parameter Settings for IO-Link Devices (as Required)	If the default values are acceptable or if you set the parameters with the actual devices, you do not need to change any settings.	---	Place the device DTMs of the IO-Link devices under Nx built-in EtherCAT - GX-ILM08C . Set the IO-Link device parameters.
↓			
9. Downloading Parameter Settings to IO-Link Devices (as Required)	Same as above.	---	Connect CX-ConfiguratorFDT to the NJ/NX-series CPU Unit or NY-series Industrial PC, select the device DTM of the IO-Link device, and then select Save to Device under Device to execute the download.
↓			
10. Checking the Indicators on the IO-Link Master Unit and the IO-Link Devices	---	---	---
↓			
11. Checking the Error Status of the IO-Link Master Unit and the IO-Link Devices	---	---	---

*1. Use the previously registered IO-Link Device Configuration Settings or use the automatically created actual IO-Link Device Configuration Settings.

*2. The default data size for each IO-Link device is 2 input bytes or 2 output bytes. The maximum data size for each device is 32 bytes.

For example, for OMRON IO-Link devices such as the E2E and E3Z, the default values can be used, and no additional PDO entries are necessary.

For other I/O devices, such as those from other companies, additional PDO entries for the I/O data sizes of those devices are required.

● Using an NX-type IO-Link Master Unit

Procedure	Description	Sysmac Studio operation	CX-ConfiguratorFDT operation
1. Mounting and Hardware Settings	Connecting to the Communications Coupler Unit	---	---
↓			
2. EtherCAT Communications Cable Wiring and IO-Link Port Wiring	---	---	---
↓			
3. Registering the IO-Link Master Unit in the EtherCAT Network Configuration	Register the EtherCAT Coupler Unit and the GX-type IO-Link Master Unit in the EtherCAT network configuration.	Drag the EtherCAT Coupler Unit under the master on the EtherCAT Configuration Edit Tab Page, click the Edit Slave Terminal Configuration Button, and register the NX-type IO-Link Master Unit on the Edit Slave Terminal Configuration Tab Page.	---
↓			
4. IO-Link Master Unit Settings (Parameter Settings and I/O Allocation Settings)	Set the parameters for the NX-type IO-Link Master Unit and make the EtherCAT I/O allocation settings for the I/O data.	Select the IO-Link Master Unit in the Edit Slave Terminal Configuration Tab Page and set the following.	---
Parameter Settings	The parameters include the communications mode and IO-Link Device Configuration Settings* ¹ for each port.	Edit Unit Operation Settings Button	---
I/O Entry Mapping (Allocation of I/O Data)	Add I/O entries to the default I/O entry mapping for the connected IO-Link devices.* ²	Edit I/O Allocation Settings Button	---
↓			
5. Programming			
Cyclic Communications	In the user program, specify the device variables allocated to the I/O ports that are equivalent to the I/O data of the IO-Link Master Unit. Use the Input Data Enabled Flags as input conditions.	Create the programs with POUs under Programming .	---
Message Communications	Program communications instructions for the objects in the IO-Link Master Unit and the IO-Link devices.	Create the programs with POUs under Programming .	---
↓			

Procedure	Description	Sysmac Studio operation	CX-ConfiguratorFDT operation
6. Turning ON Power and Going Online from the Sysmac Studio	Turn ON the power supply to the entire system and connect the Sysmac Studio.	Select Online under Controller to go online.	---
↓			
7. Downloading the Network Configuration Information and User Program to the CPU Unit or Industrial PC	The EtherCAT Slave Terminal settings are also downloaded.	Select Synchronization - Transfer To Controller under Controller to download the network configuration information and user program.	---
↓			
8. Parameter Settings for IO-Link Devices (as Required)	If the default values are acceptable or if you set the parameters with the actual devices, you do not need to change any settings.	---	Place device DTMs for the IO-Link devices under Nx built-in EtherCAT - NX-ECC Coupler - NX-ILM400 , or NX Coupler USB - NX-ILM400 . Set the IO-Link device parameters.
↓			
9. Downloading Parameter Settings to IO-Link Devices (as Required)	Same as above.	---	Connect CX-ConfiguratorFDT to the NJ/NX-series CPU Unit or NY-series Industrial PC, select the device DTM of the IO-Link device, and then select Save to Device under Device to execute the download.
↓			
10. Checking the Indicators on the IO-Link Master Unit and the IO-Link Devices	---	---	---
↓			
11. Checking the Error Status of the IO-Link Master Unit Ports and the IO-Link Devices	---	---	---

*1. Use the previously registered IO-Link Device Configuration Settings or use the automatically created actual IO-Link Device Configuration Settings.

*2. The default data size for each IO-Link device is 2 input bytes or 2 output bytes. The maximum data size for each device is 32 bytes.

If the I/O size of an IO-Link device is 2 input bytes or smaller or 2 output bytes or smaller, the default setting can be used, and no additional I/O entries are required.

If the I/O size of an IO-Link device is 3 input bytes or larger or 3 output bytes or larger, you must add an I/O entry for the required data size.

1-6-2 Controller Communications with EtherNet/IP

● Using an NJ/NX-series CPU Unit or NY-series Industrial PC as the Controller

For details on the basic operating procedures, refer to *A-1-2 Using an NJ/NX-series CPU Unit or NY-series Industrial PC with EtherNet/IP Communications* on page A-10.

● Using a CJ/CP/CS-series PLC or a Controller from Another Company

For details on the basic operating procedures, refer to *A-1-3 Using a CJ/CP/CS-series PLC or a Controller from Another Company with EtherNet/IP Communications* on page A-16.

1-6-3 Controller Communications with NX Bus

The startup procedures are as follows when the controller is an NX-series CPU Unit.

Overall Procedure

Step	Reference
1. Mounting and Hardware Settings	<ul style="list-style-type: none"> User's manual of the IO-Link Master Unit User's manuals of the IO-Link devices
2. Wiring IO-Link Ports	<ul style="list-style-type: none"> <i>Section 2 Part Names and Wiring</i>, IO-Link master user's manuals, and IO-Link device user's manuals
3. IO-Link Master Unit Settings (NX Unit Settings)	<ul style="list-style-type: none"> <i>Section 3 Parameter Settings</i> <i>Section 4 I/O Data</i>
4. Programming	<ul style="list-style-type: none"> <i>NJ/NX-series CPU Unit Software User's Manual</i> (Cat. No. W501) <i>Section 6 IO-Link System Communications</i> <i>Section 4 I/O Data</i> <i>Section 5 Status and Software Switches Other Than for I/O Data</i> <i>NJ/NX-series Instructions Reference Manual</i> (Cat. No. W502)
5. Turning ON the Power Supply and Going Online with the Support Software	<ul style="list-style-type: none"> <i>2-1 Part Names and Functions</i> on page 2-2 <i>6-1 Types and Startup of Communications for IO-Link Systems</i> on page 6-2 <i>Sysmac Studio Version 1 Operation Manual</i> (Cat. No. W504)
6. Downloading the Controller Configuration Information and the User Program	<ul style="list-style-type: none"> <i>Sysmac Studio Version 1 Operation Manual</i> (Cat. No. W504)
7. Parameter Settings for IO-Link Devices (as Required)	<ul style="list-style-type: none"> <i>8-4 CX-ConfiguratorFDT Procedures</i> on page 8-14
8. Downloading Parameter Settings to IO-Link Devices (as Required)	<ul style="list-style-type: none"> <i>8-4 CX-ConfiguratorFDT Procedures</i> on page 8-14
9. Checking the Indicators on the IO-Link Master Unit and the IO-Link Devices	<ul style="list-style-type: none"> <i>10-1-7 Checking for Errors and Troubleshooting with the Indicators on the Front Panel of the IO-Link Master Unit</i> on page 10-12

10. Checking the Error Status of the IO-Link Master Unit and the IO-Link Devices

• 10-2-3 Sysmac Event Codes and Troubleshooting on page 10-20

Procedure Details

● Using an NX1P2 CPU Unit as the Controller

Step	Meaning	Sysmac Studio operation	CX-ConfiguratorFDT operation
1. Mounting and Hardware Settings	Connect to the CPU Unit.	---	---
↓			
2. Wiring IO-Link Ports	---	---	---
↓			
3. IO-Link Master Unit Settings (NX Unit Settings)	Set the parameters for the NX-type IO-Link Master Unit and make the CPU Unit allocation settings for the I/O data.	Select the IO-Link Master Unit under CPU Unit and Expansion Rack - CPU Rack in Configurations and Setup , then set the following.	---
Parameter Settings	The parameters include the communications mode and IO-Link Device Configuration Settings* ¹ for each port.	Edit Unit Operation Settings Button	---
I/O Entry Mapping (Allocation of I/O Data)	Add PDO entries for the connected IO-Link devices to the default PDO mapping.* ²	Edit I/O Allocation Settings Button	---
↓			
4. Programming			
Cyclic Communications	In the user program, specify the device variables allocated to the I/O ports that are equivalent to the I/O data of the IO-Link Master Unit. (Use the Input Data Enabled Flags as input conditions.)	Create the programs with POUs under Programming .	---
Message Communications	Program communications instructions for the objects in the IO-Link Master Unit and the IO-Link devices.	Create the programs with POUs under Programming .	---
↓			
5. Turning ON Power and Going Online from the Sysmac Studio	Turn ON the power supply to the entire system and connect the Sysmac Studio.	Select Online under Controller to go online.	---
↓			
6. Downloading the Controller Configuration Information and the User Program	The NX Unit settings are also downloaded.	Select Synchronization - Transfer To Controller under Controller to download the network configuration information and user program.	---
↓			

Step	Meaning	Sysmac Studio operation	CX-ConfiguratorFDT operation
7. Parameter Settings for IO-Link Devices (as Required)	If the default values are acceptable or if you set the parameters with the actual devices, you do not need to change any settings.	---	Place the device DTM of the IO-Link devices under NX CPU Unit Bus - NX-ILM400 . Set the IO-Link device parameters.
↓			
8. Downloading Parameter Settings to IO-Link Devices (as Required)	Same as above.	---	Connect CX-ConfiguratorFDT to the CPU Unit, select the device DTM of the IO-Link device, and then select Save to Device under Device to execute the download.
↓			
9. Checking the Indicators on the IO-Link Master Unit and the IO-Link Devices	---	---	---
↓			
10. Checking the Error Status of the IO-Link Master Unit Ports and the IO-Link Devices	---	---	---

- *1. Use the previously registered IO-Link Device Configuration Settings or use the IO-Link Device Configuration Settings created with automatic recognition.
- *2. The default data size for each IO-Link device is 2 input bytes or 2 output bytes. The maximum data size for each device is 32 bytes.
 If the I/O size of an IO-Link device is 2 input bytes or smaller or 2 output bytes or smaller, the default setting can be used, and no additional I/O entries are required.
 If the I/O size of an IO-Link device is 3 input bytes or larger or 3 output bytes or larger, you must add an I/O entry for the required data size.

2

Part Names and Wiring

This section describes the part names and wiring methods that are common to all IO-Link Systems.

2-1	Part Names and Functions	2-2
2-1-1	Appearance of the IO-Link Master Units	2-2
2-1-2	Indicators on IO-Link Master Units	2-2
2-1-3	Terminals for Connecting the IO-Link Master Unit to IO-Link Devices	2-3
2-2	Communications Modes and IO-Link Wiring	2-5
2-2-1	IO-Link Mode	2-5
2-2-2	SIO (DI) Mode	2-6
2-2-3	SIO (DO) Mode	2-8
2-3	Supplying Unit Power and I/O Power	2-9
2-3-1	Unit Power Supply and I/O Power Supply Methods	2-9
2-3-2	Calculating the Current Consumption of the IO-Link Master Unit from the I/O Power Supply	2-10
2-3-3	Precautions for the Unit Power Supply and the I/O Power Supply	2-11

2-1 Part Names and Functions

This section gives the names and functions of the devices that make up an IO-Link System. For information on other parts, refer to the manual for the specific IO-Link master.

2-1-1 Appearance of the IO-Link Master Units

Refer to the manuals for NX-type and GX-type IO-Link Master Units.

2-1-2 Indicators on IO-Link Master Units

The front panel indicators on the NX-type and GX-type IO-Link Master Units that are related to the IO-Link System are given in the following table.

Indicator		Name	Color	Status	Meaning
NX-type IO-Link Master Unit	GX-type IO-Link Master Unit				
C	C/E	IO-Link Comm.	Green	Lit	Initial processing is in progress or IO-Link communications are in progress in IO-Link Mode.
				Not lit	<ul style="list-style-type: none"> IO-Link communications are stopped in IO-Link Mode. Or IO-Link Mode is not used.
E		IO-Link Error	Red	Lit	A hardware error or other critical error has occurred.
				Flashing (1-s intervals)	One of the following occurred in IO-Link Mode. <ul style="list-style-type: none"> IO-Link communications error I/O cable short-circuit Device configuration verification error Error-level device event
				Not lit	<ul style="list-style-type: none"> There are no IO-Link communications errors in IO-Link Mode. Or IO-Link Mode is not used.

Indicator		Name	Color	Status	Meaning
NX-type IO-Link Master Unit	GX-type IO-Link Master Unit				
C/Q	C/Q	C/Q status	Yellow	Lit	<ul style="list-style-type: none"> The digital input signal is ON in SIO (DI) Mode. The digital output signal is ON in SIO (DO) Mode. The digital input signal for pin 2 is ON during operation in IO-Link Mode.
				Not lit	<ul style="list-style-type: none"> The digital input signal is OFF in SIO (DI) Mode. The digital output signal is OFF in SIO (DO) Mode. The digital input signal for pin 2 is OFF during operation in IO-Link Mode. The indicator is not lit when the port is disabled.

2-1-3 Terminals for Connecting the IO-Link Master Unit to IO-Link Devices

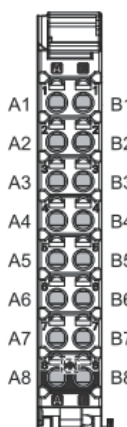
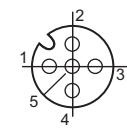
IO-Link Master Unit	NX-type NX-ILM400	GX-type GX-ILM08C
I/O connection terminals/connectors	Screwless clamping terminal block (16 terminals) × 1	M12 connectors (type A, A-coding, female) × 8
Appearance		

NX-type NX-ILM400

Terminal No.	Abbreviation	Signal name	Terminal No.	Abbreviation	Signal name
A1	P1_C/Q	Port 1_C/Q	B1	P2_C/Q	Port 2_C/Q
A2	P1_DI	Port 1_DI	B2	P2_DI	Port 2_DI
A3	P1_L+	Port 1_L+	B3	P2_L+	Port 2_L+
A4	P1_L-	Port 1_L-	B4	P2_L-	Port 2_L-
A5	P3_C/Q	Port 3_C/Q	B5	P4_C/Q	Port 4_C/Q
A6	P3_DI	Port 3_DI	B6	P4_DI	Port 4_DI
A7	P3_L+	Port 3_L+	B7	P4_L+	Port 4_L+
A8	P3_L-	Port 3_L-	B8	P4_L-	Port 4_L-

GX-type GX-ILM08C

Pin No.	Signal	Description
1	L+	Power supply +
2	DI	Digital input
3	L-	Power supply -
4	C/Q	IO-Link communications/signal wires
5	n/a	Not used.



Precautions for Correct Use

The L+ signal is output regardless of the communications mode.

- IO-Link Mode
 - SIO (DI) Mode
 - SIO (DO) Mode
 - Disabled
-

2-2 Communications Modes and IO-Link Wiring

This section describes the wiring between the IO-Link Master Unit and the IO-Link devices for each communications mode.

2-2-1 IO-Link Mode

The wiring in IO-Link Mode is described below.

NX-type IO-Link Master Unit

For an NX-type IO-Link Master Unit, the wiring differs when digital inputs for pin 2 are used and when it is not used, as indicated in the following figures.

● Connecting IO-Link Devices without Digital Inputs for Pin 2

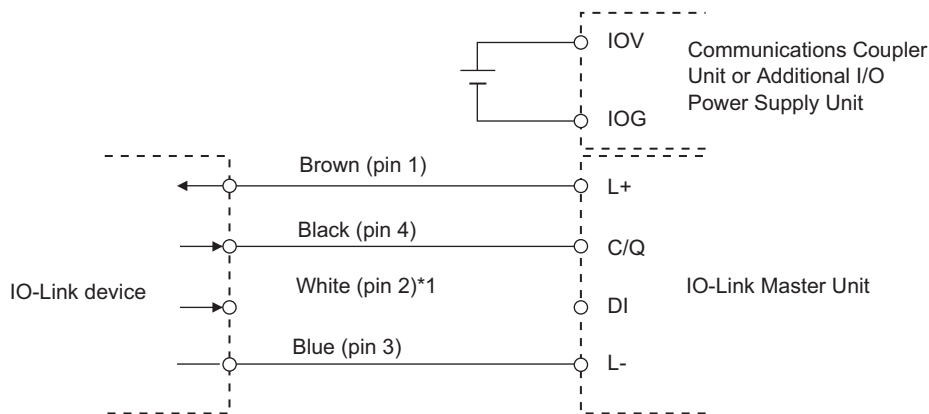

*1. If you do not use digital inputs for pin 2, a DI (white) connection is not required.

● Connecting IO-Link Devices with Digital Inputs for Pin 2

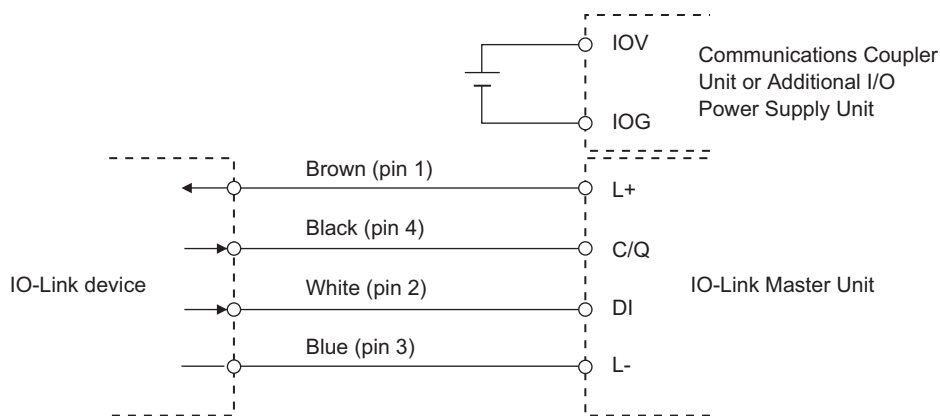

GX-type IO-Link Master Unit

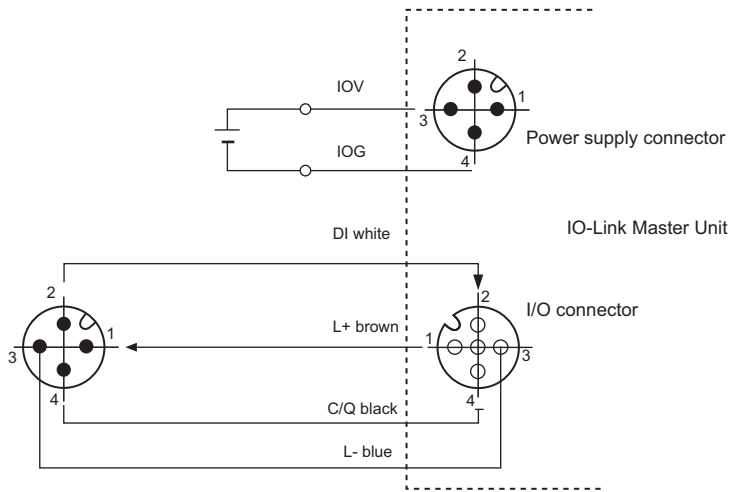

Note Even if you connect to IO-Link devices without digital inputs for pin 2, connect pin 2 as shown in the above figure. This is because connectors on the IO-Link devices and the cable with connectors on both ends connect pin 2. However, because no data enters pin 2 of the IO-Link Master Unit, digital IO-Link input data is always OFF.

2-2-2 SIO (DI) Mode

The wiring in SIO (DI) Mode for each sensor wiring type and power supply method is given the following figures.

Wiring Three-wire Sensors

● NX-type IO-Link Master Unit

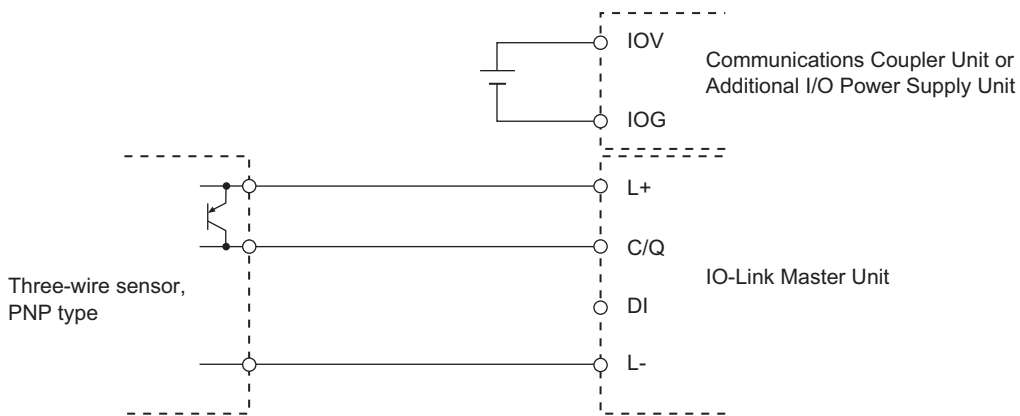

The DI terminal cannot be used.

● GX-type IO-Link Master Unit

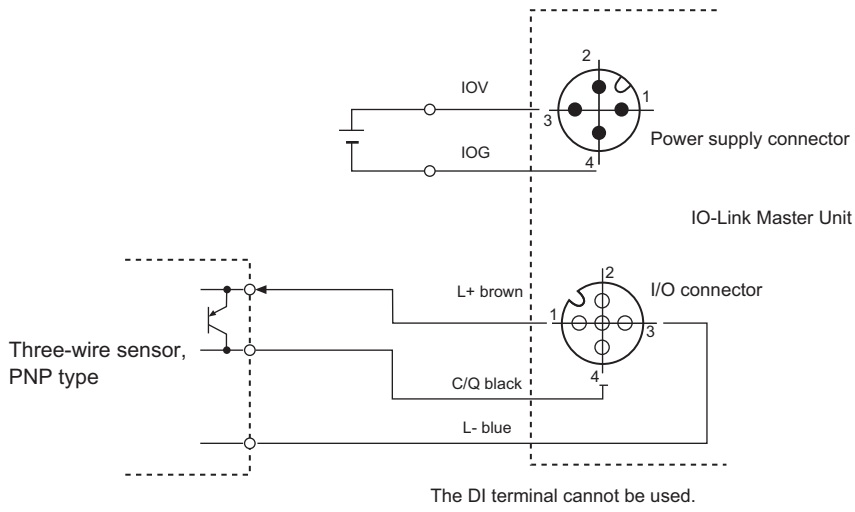

Wiring Two-wire Sensors

● NX-type IO-Link Master Unit

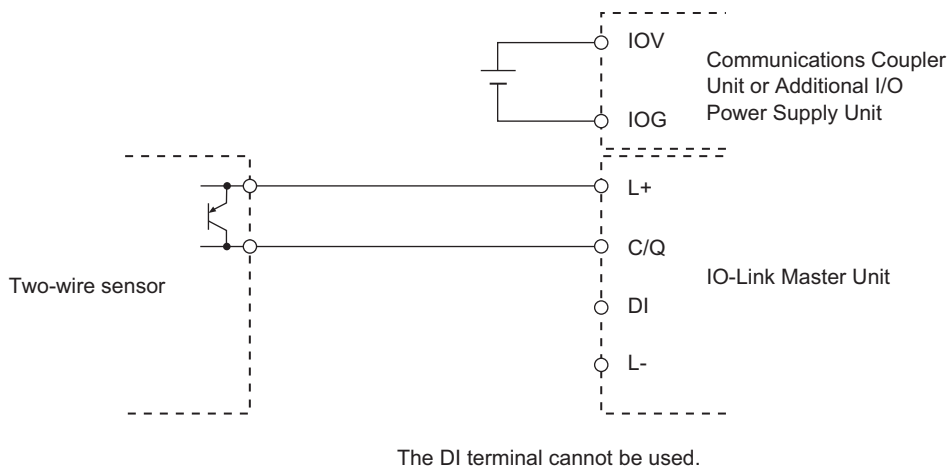

● GX-type IO-Link Master Unit

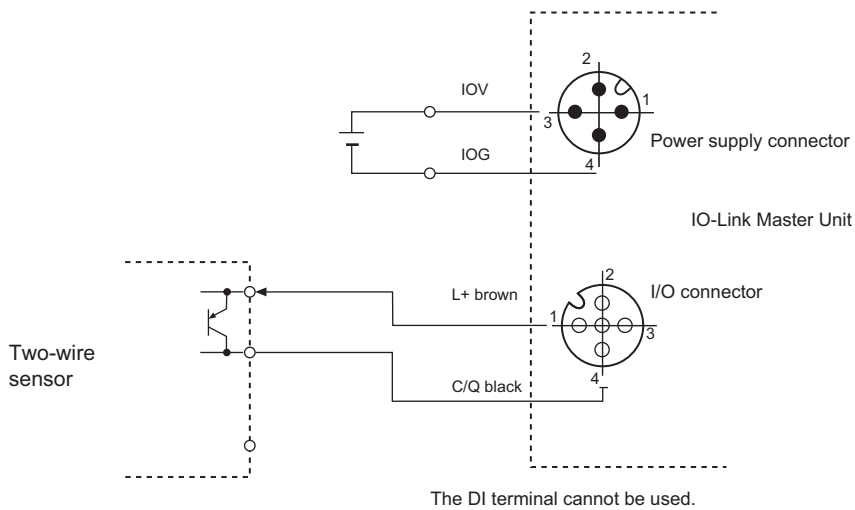

2-2-3 SIO (DO) Mode

The wiring in SIO (DO) Mode is described below.

Wiring Output Devices

- **NX-type IO-Link Master Unit**

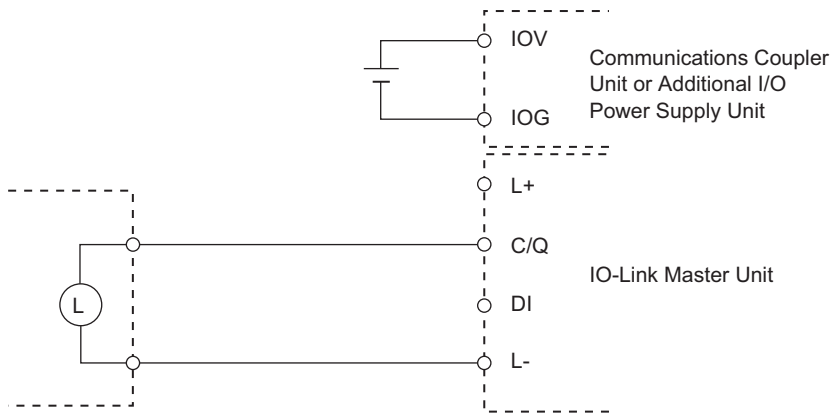

The DI terminal cannot be used.

- **GX-type IO-Link Master Unit**

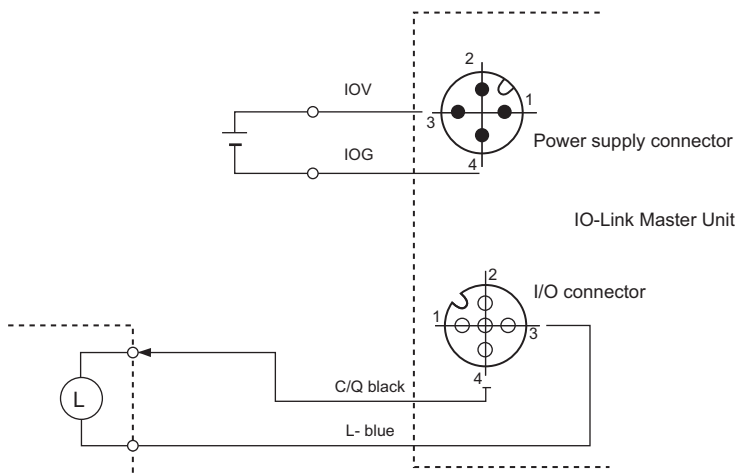

The DI terminal cannot be used.

2-3 Supplying Unit Power and I/O Power

This section describes the Unit power supply and I/O power supply to the IO-Link Master Units.

2-3-1 Unit Power Supply and I/O Power Supply Methods

The Unit power supply and I/O power supply methods depend on the type of IO-Link Master Unit as described below.

NX-type IO-Link Master Unit

The Unit power supply and I/O power supply methods depend on the connection position of the IO-Link Master Unit as described below.

- When the IO-Link Master Unit is connected to a CPU Unit:

The Unit power supply is provided from the CPU Unit or an Additional NX Unit Power Supply Unit. The I/O power supply is provided from an Additional I/O Power Supply Unit.

- When the IO-Link Master Unit is connected to a Communications Coupler Unit:

Both the Unit power supply and I/O power supply are provided from the Communications Coupler Unit or an Additional I/O Power Supply Unit.

The I/O power supply is branched in the IO-Link Master Unit and supplied to the connected devices from the ports.

Example: IO-Link Master Unit Connected to an EtherCAT Coupler Unit

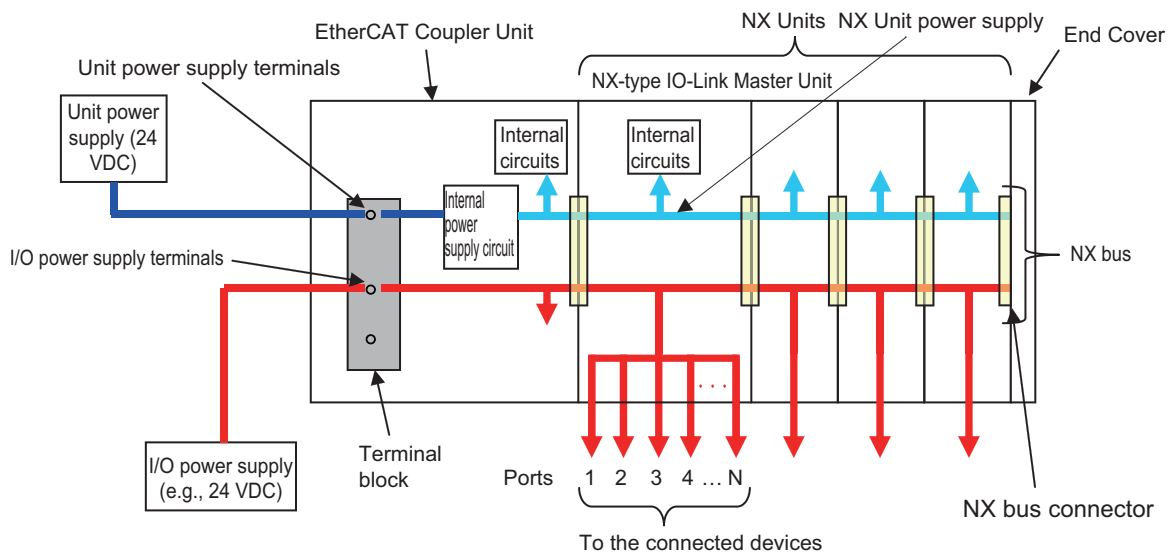

Note Even if the Unit power supply is not supplied, if you supply the I/O power supply, the I/O power supply is supplied to the connected devices from the ports.

Refer to the user's manual for the connected CPU Unit or Communications Coupler Unit for details on Unit power supply and I/O power supply methods.

GX-type IO-Link Master Unit

Directly supply the Unit power supply and the I/O power supply from the power supply port of the IO-Link Master Unit.

The I/O power supply is branched in the IO-Link Master Unit and supplied to the connected devices from the ports.

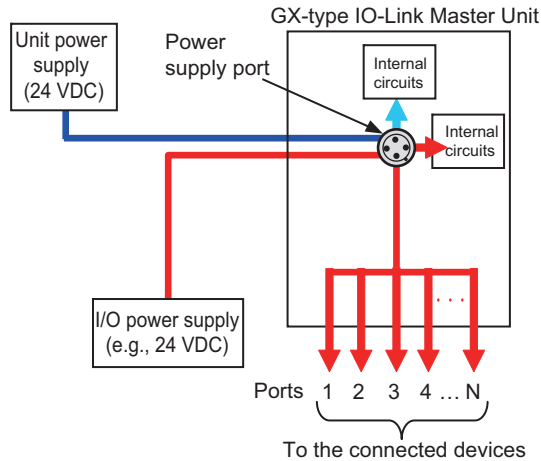

Note Even if the Unit power supply is not supplied, if you supply the I/O power supply, the I/O power supply is supplied to the connected devices from the ports.

2-3-2 Calculating the Current Consumption of the IO-Link Master Unit from the I/O Power Supply

The current consumption of the IO-Link Master Unit from the I/O power supply is calculated as shown below.

$$\begin{aligned}
 & \text{(Current consumption of the IO-Link Master Unit from the I/O power supply)} \\
 = & \text{(Current consumption of the IO-Link Master Unit itself from the I/O power supply)} \\
 & + \text{(Total input current of ports used for inputs)} \\
 & + \text{(Total current consumption of external connected devices)} \\
 & + \text{(Total load current of ports used for outputs)}
 \end{aligned}$$

2-3-3 Precautions for the Unit Power Supply and the I/O Power Supply

There are two IO-Link Master Unit power supply systems: the Unit power supply and the I/O power supply.

- Supply the Unit power supply and the I/O power supply from separate sources.



Precautions for Correct Use

You must supply the Unit power supply and the I/O power supply from separate sources.

If you supply power from the same power supply, noise may cause malfunctions.

- There are no restrictions on the sequence of turning ON the power supplies for either NX-type or GX-type IO-Link Master Units.



Additional Information

You can check the supply status of the I/O power supply to the IO-Link Master Unit with the "I/O Power On/Off Status" in the I/O data.

3

Parameter Settings

This section describes the parameter settings for IO-Link Systems.

3-1	Types of Parameters	3-2
3-2	IO-Link Master Unit Parameters	3-3
3-3	Parameters for IO-Link Devices	3-6

3-1 Types of Parameters

This section describes the parameters for an IO-Link System.

In an IO-Link System, there are parameters for the IO-Link Master Unit and parameters for the IO-Link devices.

The parameters for the IO-Link Master Unit are set from the IO-Link Master Unit Configuration Tool.

For the operating procedure, refer to *8-2-2 Setting Parameters in the IO-Link Master Unit* on page 8-7.

The parameters for IO-Link devices are set from the CX-ConfiguratorFDT.

For the operating procedure, refer to *8-4-6 Creating the Network Configuration* on page 8-18.

3-2 IO-Link Master Unit Parameters

This section describes the parameters for IO-Link Master Units.

Set the following parameters for each port from the IO-Link Master Unit Configuration Tool or with communications instructions.

The settings of all of the following parameters can be backed up and restored.

For details, refer to the object list for each Master Unit.

Refer to *6-3-2 Message Communications with the IO-Link Master* on page 6-9 for information on instructions.

Setting (= object name)	Meaning	Default	Setting range	NX-type IO-Link Master Unit		GX-type IO-Link Master Unit	
				Index	Sub-index	Index	Sub-index
IO-Link Device Verification Setting	<p>This setting specifies whether to verify that the IO-Link devices connected to the ports match the IO-Link devices in the IO-Link Device Configuration Settings when IO-Link communications start.</p> <p>You can verify the vendor ID, device ID, IO-Link revision, and serial number of the connected IO-Link device for each port using either of the following two patterns.</p> <ul style="list-style-type: none"> • Vendor ID + Device ID + IO-Link revision • Vendor ID + Device ID + Serial number + IO-Link revision 	00 hex: Do not check.	00 to 02 hex 00 hex: Do not check. 01 hex: Verify the vendor ID, device ID, and IO-Link revision. 02 hex: Verify the vendor ID, device ID, and IO-Link revision.	5001 hex	01 to 04 hex	3011 hex	01 to 08 hex

3 Parameter Settings

Setting (= object name)		Meaning	Default	Setting range	NX-type IO-Link Master Unit		GX-type IO-Link Master Unit	
					Index	Subindex	Index	Subindex
IO-Link Device Configuration Settings ^{*1}	Device ID	The type of IO-Link device.	00000000 hex	00000000 to 00FFFFFF hex	5006 to 5009 hex	01 hex	80*0 hex *: 0 to 7	04 hex
	Vendor ID	The vendor ID of the IO-Link device.	00000000 hex	00000000 to 0000FFFF hex		02 hex		05 hex
	Serial No.	The serial number of the IO-Link device.	---	16 characters max.		05 hex	80*1 hex *: 0 to 7	None
	IO-Link Revision ^{*2}	The IO-Link revision of the IO-Link device. • Set the major revision in the 4 upper bits, and the minor revision in the 4 lower bits.	00 hex	00 to FF hex		06 hex	80*0 hex *: 0 to 7	20 hex
	Process Data In Length ^{*3}	The size (in bytes) of the process input data from the IO-Link device.	02 hex (2 bytes)	00 to 20 hex (0 to 32 bytes)		09 hex		24 hex
	Process Data Out Length ^{*4}	The size (in bytes) of the process output data from the IO-Link device.	02 hex (2 bytes)	00 to 20 hex (0 to 32 bytes)		0A hex	25 hex	
	Master Control Communications Mode Setting	Set the communications mode for each port.	03 hex: IO-Link Mode	00 to 03 hex 00 hex: Disable Port 01 hex: SIO (DI) Mode 02 hex: SIO (DO) Mode 03 hex: IO-Link Mode		0B hex	28 hex	
Backup Setting	Make this setting to back up the parameter settings of the IO-Link devices in the IO-Link Master Unit. Specify whether to enable or disable backup for each port.	00 hex	00 to 01 hex 00 hex: Disables backup 01 hex: Enables backup ^{*5}	5002 hex	01 to 04 hex	3012 hex	01 to 08 hex	
Restoration Setting	Make this setting to restore the parameter settings of the IO-Link devices from the IO-Link Master Unit. Specify whether to enable or disable restoration for each port.	00 hex	00 to 01 hex 00 hex: Disables restoration. 01 hex: Enables restoration. ^{*6}	5003 hex	01 to 04 hex	3013 hex	01 to 08 hex	
Load Rejection Output Setting for Controller Communications Errors	Set whether to turn OFF outputs from the IO-Link Master Unit when an error occurs in communications with the controller. You can enable or disable this function separately for each port.	00 hex	00 to 01 hex 00 hex: Load rejection is ON ^{*7} 01 hex: Load rejection is OFF ^{*8}	5004 hex	01 to 04 hex	3014 hex	01 to 08 hex	

Setting (= object name)	Meaning	Default	Setting range	NX-type IO-Link Master Unit		GX-type IO-Link Master Unit	
				Index	Sub-index	Index	Sub-index
Digital Input Filter Setting	Filters digital input values. Make this setting for each port.* ⁹	3 (1 m)	0: No filter 1: 0.25ms 2: 0.5ms 3: 1ms 4: 2ms 5: 4ms 6: 8ms 7: 16ms 8: 32ms 9: 64ms 10: 128ms 11: 256ms	5005 hex	01 to 04 hex	3015 hex	01 to 08 hex
Digital Input Collection Setting* ¹⁰	<ul style="list-style-type: none"> Enable or disable the digital input collection for each port in IO-Link Mode. Digital input collection cannot be used in SIO (DI) Mode or SIO (DO) Mode and this setting is ignored. 	00 hex	00 to 01 hex 00 hex: Digital Input Collection Disable 01 hex: Digital Input Collection Enable	501A hex	01 to 04 hex	320B hex	01 to 08 hex
Offset Setting of Digital Input Collection* ¹⁰	<ul style="list-style-type: none"> Specify the offset of the bit data to be collected in the input data from the IO-Link device, when the digital input collection is enabled for each port in IO-Link Mode. When the digital input collection is disabled in IO-Link Mode, this setting is ignored. This setting is also ignored in SIO (DI) Mode or SIO (DO) Mode. 	00 hex	00 to FF hex	501B hex	01 to 04 hex	320C hex	01 to 08 hex

*1. You can check the codes for the IO-Link Device Configuration Settings in the manuals for the IO-Link devices.

*2. Setting example: Set 11 hex for revision 1.1.

*3. Set the IO-Link input data size to a value equal to or greater than the IO-Link input data size of the device.

*4. Set the IO-Link output data size to a value equal to or greater than the IO-Link output data size of the device

*5. Even if the backup function is enabled, the backup data will be restored if restoring data is enabled with the Restoration Setting and the parameter settings for the IO-Link devices are different from the backup data.

*6. Even if restoring data is enabled, the settings will be backed up if there is no backup data in the IO-Link Master Unit.

*7. Digital outputs are cleared and IO-Link communications are disabled.

*8. Digital outputs are held and IO-Link communications are maintained.

*9. Digital input values in SIO (DI) Mode and digital input values for pin 2 are specified separately for each port.

*10. These settings are supported with the unit version 1.1 or later.

3-3 Parameters for IO-Link Devices

Refer to the instruction manuals for individual IO-Link devices for the IO-Link device parameters.

In particular, for the parameters of OMRON IO-Link devices, refer to the *Index List* for the IO-Link devices in *Related Manuals* on page 21.

4

I/O Data

This section describes the I/O data for IO-Link Systems.

4

4-1	Outline of I/O Data	4-2
4-1-1	Introduction to I/O Data and Types of I/O Data	4-2
4-1-2	Type of I/O Data	4-2
4-1-3	Allocated I/O Data According to Communications Mode	4-5
4-2	I/O Data Details	4-7
4-2-1	Input Data (from the IO-Link Master Unit to the Controller)	4-7
4-2-2	Output Data (from the Controller to the IO-Link Master Unit)	4-15
4-3	I/O Allocation Settings	4-17
4-3-1	What Are I/O Allocation Settings?	4-17
4-3-2	When Are I/O Allocation Settings Required?	4-17
4-3-3	I/O Allocation Setting Method	4-18
4-4	Specifying I/O Data in the User Program	4-19
4-4-1	Controller Communications Using Ether- CAT (NX-type IO-Link Master Unit or GX-type IO-Link Master Unit)	4-19
4-4-2	Controller Communications Using EtherNet/IP (NX-type IO-Link Master Unit)	4-19
4-4-3	Controller Communications Using NX bus (NX-type IO-Link Master Unit) ..	4-19

4-1 Outline of I/O Data

This section introduces the I/O data of the IO-Link Master Unit.

4-1-1 Introduction to I/O Data and Types of I/O Data

The I/O data is the data for cyclic communications between the IO-Link Master Unit and the controller. The following types of I/O data are available.

- Process input data to and process output data from each connected IO-Link devices (process data)^{*1}
- Digital inputs for pin 2, digital I/O data of the connected IO-Link devices
- IO-Link Master Status

*1. For the I/O data (process data) of OMRON IO-Link devices, refer to the *Index List* of the IO-Link devices in *Related Manuals* on page 21.

4-1-2 Type of I/O Data

This section describes the types of I/O data.

The following I/O data is contained in the IO-Link Master Unit.

Input Data (from the IO-Link Master Unit to the Controller)

● IO-Link Master Status

Data name (= object name)	Description	Size	Default I/O allocation	IO-Link Master Unit	
				NX	GX
Input Data Enabled Flags	Indicates whether the IO-Link process input data in IO-Link Mode is valid or invalid at the controller for each port.	1 bit per port	Yes	2 bytes	2 bytes
IO-Link Communications Module Processing Error	Indicates the error status of the IO-Link communications processing section.	1 bit	Yes		
I/O Power On/Off Status	Indicates the status of the I/O power supply to the IO-Link Master Unit.	1 bit	Yes		
I/O Port Error Status	Indicates the following errors for each port. IO-Link communications error, short-circuit in I/O cable, device configuration verification error, device I/O size error, PDO mapping error, error-level device event, and warning-level device event	1 bit per port	Yes	4 bytes	8 bytes

● Digital Input Data from IO-Link Devices and Non-IO-Link Devices

Data name (= object name)	Description	Size	Default I/O allocation	IO-Link Master Unit	
				NX	GX
Digital Input Data	Digital inputs with pin 2 in IO-Link Mode, data collected in IO-Link Mode and when the digital input data collection function is enabled, or digital input data in SIO(DI) Mode.* ¹	1 bit per port	*2	2 bytes	2 bytes

*1. The digital input data collection function is supported in IO-Link Master Unit with unit version 1.1 or later.

*2. Unit version 1.0: Not provided
Unit version 1.1 or later: Provided

✓ Version Information

Digital Input Data and Digital Output Data are allocated by default for the IO-Link Master Unit with unit version 1.1 or later.

● Process Input Data from IO-Link Devices

Data name (= object name)	Description	Size	Default I/O allocation	IO-Link Master Unit	
				NX	GX
Port 1 Input Data	This is the process input data from IO-Link devices such as sensors that are connected to port 1 in IO-Link Mode.	Maximum of 32 bytes per port	Yes* ¹	32 bytes × 4 ports	32 bytes × 8 ports
...	...				
Port 8 Input Data	This is the process input data from IO-Link devices such as sensors that are connected to port 8 in IO-Link Mode.	Maximum of 32 bytes per port	Yes* ¹		

*1. Two bytes are allocated for each port.

Note An NX-type IO-Link Master Unit has up to four ports.

● New Message Available

Data name (= object name)	Description	Size	Default I/O allocation	IO-Link Master Unit	
				NX	GX
New message available	Existence of new message.	1 bit	Yes	None	Yes

● Sysmac Error Status

Data name (= object name)	Description	Size	Default I/O allocation	IO-Link Master Unit	
				NX	GX
Sysmac Error Status* ¹	This status contains status flags that are used to check errors that occur and confirm when they have been eliminated.	1 byte	Yes	None	1 byte

*1. GX-type IO-Link Master Unit only.

For an NX-type IO-Link Master Unit, the Sysmac error status is located in the connected Coupler Unit.

Output Data (from the Controller to the IO-Link Master Unit)

● Digital Output Data to Non-IO-Link Devices

Data name (= object name)	Description	Size	Default I/O allocation	IO-Link Master Unit	
				NX	GX
Digital Output Data	This is the digital output data in SIO (DO) Mode.	1 bit per port	*1	2 bytes	2 bytes

*1. Unit version 1.0: Not provided
Unit version 1.1 or later: Provided



Version Information

Digital Input Data and Digital Output Data are allocated by default for the IO-Link Master Unit with unit version 1.1 or later.

● Process Output Data from IO-Link Devices

Data name (= object name)	Description	Size	Default I/O allocation	IO-Link Master Unit	
				NX	GX
Port 1 Output Data	This is the process output data from IO-Link devices such as actuators that are connected to port 1 in IO-Link Mode.	Maximum of 32 bytes per port	Yes*1	32 bytes × 4 ports	32 bytes × 8 ports
...	...				
Port 8 Output Data	This is the process output data from IO-Link devices such as actuators that are connected to port 8 in IO-Link Mode.	Maximum of 32 bytes per port	Yes*1		

*1. Two bytes are allocated for each port.

Note An NX-type IO-Link Master Unit has up to four ports.

4-1-3 Allocated I/O Data According to Communications Mode

With an OMRON IO-Link Master Unit, you can set the communications mode for each port.

The types of data exchange are set in advance with the communications mode parameters in the OMRON IO-Link Master Unit. Refer to 7-2 *Connected Device Verification* on page 7-6 and 3-2 *IO-Link Master Unit Parameters* on page 3-3.

Input/output	Data name (= object name)	Communications mode		
		IO-Link Mode	SIO (DI) Mode	SIO (DO) Mode
Input Data	Input Data Enabled Flags	Used as the status indicating whether the IO-Link process input data is valid or invalid at the controller.	Not used. Always FALSE.	Not used. Always FALSE.
	IO-Link Communications Module Processing Error	Used as the status for checking the occurrence of an error in the IO-Link communications processing section, regardless of the communications mode.		
	I/O Power On/Off Status	Used as the status for checking the supply of I/O power to the IO-Link Master Unit, regardless of the communications mode.		
	I/O Port Error Status	Used as the status for checking the occurrence of an error related to the I/O port, such as the IO-Link communications error.	Not used. Always FALSE.	Not used. Always FALSE.
	Sysmac Error Status ^{*1}	Used as the status for checking the event level of a Sysmac error that has occurred in the IO-Link Master Unit, regardless of the communications mode.		
	Digital Input Data	Used as a digital input signal for pin 2 from IO-Link sensors. Used as bit data specified in the input data from the IO-Link device, when the digital input collection function ^{*2} is enabled.	Used as a digital input signal from non-IO-Link sensors.	Not used. Always OFF.
Output Data	Port □ Input Data	Used as the process input data from IO-Link sensors.	Not used. Always 0.	Not used. Always 0.
	Digital Output Data	Not used.	Not used.	Used as the digital output signals to non-IO-Link actuators.
	Port □ Output Data	Used as the process output data to IO-Link actuators.	Not used.	Not used.

*1. GX-type IO-Link Master Unit only.

For an NX-type IO-Link Master Unit, the Sysmac error status is located in the connected Coupler Unit.

*2. This function is supported in IO-Link Master Unit with unit version 1.1 or later.

Example:

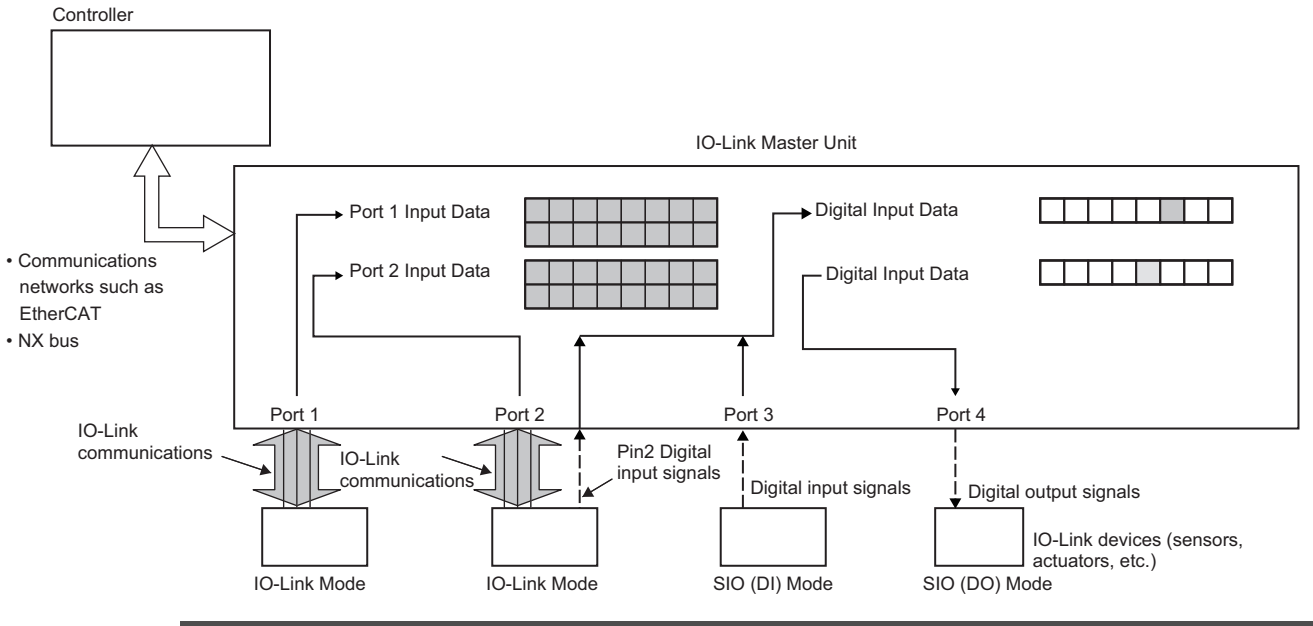

4-2 I/O Data Details

This section gives details on the I/O data.

4-2-1 Input Data (from the IO-Link Master Unit to the Controller)

This section describes the I/O data in detail.

IO-Link Master Status

Data name (= object name)	Function	Data type	Value	I/O port name	Access	Default I/O allocation	IO-Link Master Unit			
							NX	GX		
I/O Port Status	Consists of the Input Data Enabled Flags and the I/O Power On/Off Status.	WORD*1	0000 to FFFF hex	I/O Port Status	R	Yes	Yes	Yes		
Port 1 Input Data Enabled Flag	The flag is ON when the IO-Link process input data can be used by the host controller in IO-Link Mode.	BOOL	TRUE: The input data can be used. FALSE: The input data cannot be used.	Port1 IN Data Enable	R					
Port 2 Input Data Enabled Flag		BOOL	Same as above.	Port2 IN Data Enable	R					
Port 3 Input Data Enabled Flag		BOOL	Same as above.	Port3 IN Data Enable	R					
Port 4 Input Data Enabled Flag		BOOL	Same as above.	Port4 IN Data Enable	R					
Port 5 Input Data Enabled Flag		BOOL	Same as above.	Port5 IN Data Enable	R				No	Yes
Port 6 Input Data Enabled Flag		BOOL	Same as above.	Port6 IN Data Enable	R				No	Yes
Port 7 Input Data Enabled Flag		BOOL	Same as above.	Port7 IN Data Enable	R				No	Yes
Port 8 Input Data Enabled Flag		BOOL	Same as above.	Port8 IN Data Enable	R				No	Yes
IO-Link Communications Module Processing Error	This flag gives the error status of the IO-Link communications module.	BOOL	FALSE: There is no error in the IO-Link communications module. TRUE: There is an error in the IO-Link communications module.	Communication Module Error	R	Yes	Yes	Yes		
I/O Power On/Off Status	This flag gives the status of the I/O power supply to the IO-Link Master Unit.	BOOL	TRUE: Power is correctly supplied from the I/O power supply to the Unit. FALSE: Power is not correctly supplied from the I/O power supply to the Unit.	IO Pwr On	R	Yes	Yes	Yes		

Data name (= object name)	Function	Data type	Value	I/O port name	Access	Default I/O allocation	IO-Link Master Unit	
							NX	GX
I/O Port Error Status for Ports 1 and 2	This is the error status for ports 1 and 2.	WORD*1	0000 to FFFF hex	Port1_2 I/O Port Error Status	R	Yes	Yes	Yes
Port 1 I/O-Link Communications Error Flag	IO-Link communications stop for the port when this error occurs.	BOOL	TRUE: There is an IO-Link communications error. FALSE: There is no IO-Link communications error.	Port1 Communication Error	R			
Port 1 I/O Short Detected Flag	This flag indicates short-circuits in the I/O cable.	BOOL	TRUE: There is a short-circuit in the I/O cable. FALSE: There is no short-circuit in the I/O cable.	Port1 Short Error	R			
Port 1 Verification Error Flag	This flag indicates that the IO-Link device connected to the port does not match the configuration settings.	BOOL	TRUE: There is a device configuration verification error. FALSE: There is no device configuration verification error.	Port1 Compare Error	R			
Port 1 Device I/O Size Error Flag	This flag indicates that an IO-Link device with a size that is greater than the PDO size of the IO-Link Master Unit is connected.	BOOL	TRUE: There is a device I/O size error. FALSE: There is no device I/O size error.	Port1 Device IO Size Error	R			
Port 1 Error-level Device Event Flag	This flag indicates the occurrence of error-level events (i.e., errors) in the IO-Link device.	BOOL	TRUE: There is an error-level device event. FALSE: There is no error-level device event.	Port1 Device Error	R			
Port 1 Warning-level Device Event Flag	This flag indicates whether an error-level warning occurred in the IO-Link device.	BOOL	TRUE: There is a warning-level device event. FALSE: There is no warning-level device event.	Port1 Device Information	R			
Port 1 PDO Mapping Error Flag	This flag indicates that an IO-Link Master Unit with a size that is greater than the size in the PDO Map Settings is connected.	BOOL	TRUE: There is a PDO mapping error. FALSE: There is no PDO mapping error.	Port1 PDO Error	R			

Data name (= object name)		Function	Data type	Value	I/O port name	Access	Default I/O allocation	IO-Link Master Unit	
								NX	GX
I/O Port Error Status for Ports 1 and 2	Port 2 I/O-Link Communications Error Flag	IO-Link communications stop for the port when this error occurs.	BOOL	TRUE: There is an IO-Link communications error. FALSE: There is no IO-Link communications error.	Port2 Communication Error	R	Yes	Yes	Yes
	Port 2 I/O Short Detected Flag	This flag indicates short-circuits in the I/O cable.	BOOL	TRUE: There is a short-circuit in the I/O cable. FALSE: There is no short-circuit in the I/O cable.	Port2 Short Error	R			
	Port 2 Verification Error Flag	This flag indicates that the IO-Link device connected to the port does not match the configuration settings.	BOOL	TRUE: There is a device configuration verification error. FALSE: There is no device configuration verification error.	Port2 Compare Error	R			
	Port 2 Device I/O Size Error Flag	This flag indicates that an IO-Link device with a size that is greater than the PDO size of the IO-Link Master Unit is connected.	BOOL	TRUE: There is a device I/O size error. FALSE: There is no device I/O size error.	Port2 Device IO Size Error	R			
	Port 2 Error-level Device Event Flag	This flag indicates the occurrence of error-level events (i.e., errors) in the IO-Link device.	BOOL	TRUE: There is an error-level device event. FALSE: There is no error-level device event.	Port2 Device Error	R			
	Port 2 Warning-level Device Event Flag	This flag indicates whether an error-level warning occurred in the IO-Link device.	BOOL	TRUE: There is a warning-level device event. FALSE: There is no warning-level device event.	Port2 Device Information	R			
	Port 2 PDO Mapping Error Flag	This flag indicates that an IO-Link Master Unit with a size that is greater than the size in the PDO Map Settings is connected.	BOOL	TRUE: There is a PDO mapping error. FALSE: There is no PDO mapping error.	Port2 PDO Error	R			
I/O Port Error Status for Ports 3 and 4	I/O Port Error Status for Ports 3 and 4	This is the error status for ports 3 and 4.	WORD*1	Same as the I/O port error status for ports 1 and 2.	Port3_4 I/O Port Error Status	R	Yes	Yes	Yes
I/O Port Error Status for Ports 5 and 6	I/O Port Error Status for Ports 5 and 6	This is the error status for ports 5 and 6.	WORD*1	Same as the I/O port error status for ports 1 and 2.	Port5_6 I/O Port Error Status	R	Yes	None	Yes
I/O Port Error Status for Ports 7 and 8	I/O Port Error Status for Ports 7 and 8	This is the error status for ports 7 and 8.	WORD*1	Same as the I/O port error status for ports 1 and 2.	Port7_8 I/O Port Error Status	R	Yes	None	Yes

*1. You can create a UNION variable to enable specifying both WORD and BOOL (bit) data.

● Details on IO-Link Master Status

The following table gives details on the TRUE and FALSE conditions for each flag.

Flag name	TRUE conditions	FALSE conditions
Input Data Enabled Flags	<p>The Input Data Enabled Flags are used to confirm whether input data ^{*1} is enabled or disabled for input processing in the controller.</p> <p>When all of the following conditions are met:</p> <ul style="list-style-type: none"> • IO-Link communications are normal. 	<ul style="list-style-type: none"> • One of the following occurred: <ul style="list-style-type: none"> • IO-Link Communications Error • I/O Cable Short-circuit • Device Configuration Verification Error • Device I/O Size Error • Error-level Device Event • A non-IO-Link sensor is connected in IO-Link Mode.
IO-Link Communications Module Processing Error	<p>A fatal error occurred in the IO-Link communications module.</p> <p>One of the following events will also occur.</p> <p>Refer to <i>10-2-3 Sysmac Event Codes and Troubleshooting</i> on page 10-20 for details.</p> <p>NX-type IO-Link Master Unit: 849A0000 hex (IO-Link Communications Module Processing Error)</p> <p>GX-type IO-Link Master Unit: 84870000 hex (IO-Link Communications Module Processing Error)</p>	<p>A fatal error did not occur in the IO-Link communications module.</p>
I/O Power On/Off Status	<ul style="list-style-type: none"> • The IO-Link power supply to the IO-Link Master Unit is correct. 	<ul style="list-style-type: none"> • The IO-Link power supply to the IO-Link Master Unit is not correct.
IO-Link Communications Error	<p>IO-Link communications are not established.</p> <p>One of the following occurred:</p> <ul style="list-style-type: none"> • The I/O cable is broken. • The IO-Link device is disconnected from the port. • Device Configuration Verification Error • Error-level Device Event • An IO-Link device has failed. • IO-Link Master Unit failure 	<p>IO-Link communications are established.</p>
I/O Cable Short-circuit	<p>One of the following occurred:</p> <ul style="list-style-type: none"> • There is a short-circuit in the power supply to the input sensor. • There is a load short-circuit in the output. • An IO-Link device has failed. 	<p>None of the items on the left have occurred.</p>
Device Configuration Verification Error	<p>The IO-Link device that is actually connected does not match the IO-Link device in the IO-Link Device Configuration Settings. ^{*2}</p>	<p>The IO-Link device that is actually connected matches the IO-Link device in the IO-Link Device Configuration Settings.</p>

Flag name	TRUE conditions	FALSE conditions
Device I/O Size Error	One of the following occurred: <ul style="list-style-type: none"> For an input device, the size of the IO-Link device is greater than the IO-Link input data size set in the IO-Link Master Unit. For an output device, the size of the IO-Link device is different from the IO-Link output data size set in the IO-Link Master Unit. 	None of the items on the left have occurred.
Error-level Device Event	A major error or minor error occurred in the IO-Link device.	A major error or minor error did not occur in the IO-Link device.
Warning-level Device Event Flag	A warning-level event occurred in the IO-Link device.	A warning-level event did not occur in the IO-Link device.
PDO Mapping Error	Any one of the following occurred: <ul style="list-style-type: none"> For an input device, the IO-Link input data size set in the IO-Link Master Unit is greater than the PDO map size. For an output device, the IO-Link output data size set in the IO-Link Master Unit is greater than the PDO map size. 	None of the items on the left have occurred.

*1. This refers to the IO-Link process input data in the IO-Link communications.

*2. IO-Link communications will stop any ports for which the configuration does not match. The overall operation of the IO-Link Master Unit will continue.



Precautions for Correct Use

You must use the TRUE status of the Input Data Enabled Flag in the I/O data as a condition for processing the IO-Link process input data in IO-Link Mode in the user program of the controller.

New Message Available

Data name (= object name)	Function	Data type	Value	I/O port name	Default I/O allocation	IO-Link Master Unit	
						NX	GX
New Message Available	Existence of new message.	BOOL	TRUE: There is a new message. FALSE: There is no new message.	New Messages Available	Yes	No	Yes

■ Sysmac Error Status

Data name (= object name)	Function	Data type	Value	I/O port name	Default I/O allocation	IO-Link Master Unit	
						NX	GX
Sysmac Error Status	This status indicates the level of Sysmac errors that occur in the IO-Link Master Unit.* ¹	BYTE	Bits 06 and 07: Always OFF. Bit 05: Minor fault Bit 04: Observation Bits 01 to 03: Always OFF. Bit 00: Always ON.	Sysmac Error Status	Yes	No	Yes
Observation	This bit indicates whether an observation-level event occurred in the NJ/NX-series Controller or NY-series Industrial PC.* ²	BOOL	TRUE: There is an observation-level event. FALSE: There is no observation-level event.	Observation			
Minor Fault	This bit indicates whether a minor fault error occurred in the NJ/NX-series Controller or NY-series Industrial PC.* ²	BOOL	TRUE: A minor fault error occurred. FALSE: A minor fault error did not occur.	Minor Fault			

*1. GX-type IO-Link Master Unit only.

For an NX-type IO-Link Master Unit, the Sysmac error status is located in the EtherCAT Coupler Unit only.

*2. Refer to 10-2-3 *Sysmac Event Codes and Troubleshooting* on page 10-20 for details.

Digital Input Data from IO-Link Devices and Non-IO-Link Devices

Data name (= object name)	Function	Data type	Value	I/O port name	Default I/O allocation	IO-Link Master Unit	
						NX	GX
Digital Input Data	<ul style="list-style-type: none"> Digital data input for pin 2 from the IO-Link devices in IO-Link Mode. input data of the IO-Link devices that do not support digital inputs for pin 2 are not stored in digital input data. Digital input data from non-IO-Link devices in SIO (DI) Mode. 	WORD *1	0000 to FFFF hex	Digital Input Data	*2	Yes	Yes
Port 1 Digital Input Bit	This is the digital input signal to the port.	BOOL	FALSE, TRUE	Port1 Digital Input Bit		Yes	Yes
Port 2 Digital Input Bit	Same as above.	BOOL	Same as above.	Port2 Digital Input Bit		Yes	Yes
Port 3 Digital Input Bit	Same as above.	BOOL	Same as above.	Port3 Digital Input Bit		Yes	Yes
Port 4 Digital Input Bit	Same as above.	BOOL	Same as above.	Port4 Digital Input Bit		Yes	Yes
Port 5 Digital Input Bit	Same as above.	BOOL	Same as above.	Port5 Digital Input Bit		No	Yes
Port 6 Digital Input Bit	Same as above.	BOOL	Same as above.	Port6 Digital Input Bit		No	Yes
Port 7 Digital Input Bit	Same as above.	BOOL	Same as above.	Port7 Digital Input Bit		No	Yes
Port 8 Digital Input Bit	Same as above.	BOOL	Same as above.	Port8 Digital Input Bit		No	Yes

*1. When you use an NJ/NX-series CPU Unit or NY-series Industrial PC as the controller, you can create a UNION variable to enable specifying both WORD and BOOL (bit) data.

*2. Unit version 1.0: Not provided
Unit version 1.1 or later: Provided



Additional Information

With the digital input collection, the bit data in the input data from the IO-Link devices can be collected to the digital input data of the IO-Link Master Unit. Refer to *7-7 Digital Input Collection* on page 7-25 for the details on the digital input collection.

Process Input Data from IO-Link Devices

Data name (= object name)		Function	Data type	Value	I/O port name	Default I/O allocation	IO-Link Master Unit	
							NX	GX
Port 1 Input Data	Port 1 Input Data 01	This is input data from the IO-Link device in IO-Link Mode. The format is defined by the IO-Link device. You can allocate data with a different data size to each port.	ARRAY [0..1] OF BYTE	0000 to FFFF hex	Port1 Input Data 01	Yes	Ports 1 to 4 only	Ports 1 to 8
	Port 1 Input Data 02	Same as for Port 1 Input Data 01.	ARRAY [0..1] OF BYTE	0000 to FFFF hex	Port1 Input Data 02	No	Ports 1 to 4 only	Ports 1 to 8
	...							
Port 1 Input Data	Port 1 Input Data 16	Same as for Port 1 Input Data 01.	ARRAY [0..1] OF BYTE	0000 to FFFF hex	Port1 Input Data16	No	Ports 1 to 4 only	Ports 1 to 8
	...							
	Port 2 Input Data 01	Same as for Port 1 Input Data.	ARRAY [0..1] OF BYTE	0000 to FFFF hex	Port2 Input Data 01	Yes	Ports 1 to 4 only	Ports 1 to 8
Port 2 Input Data	...							
	Port 2 Input Data 16	Same as for Port 1 Input Data.	ARRAY [0..1] OF BYTE	0000 to FFFF hex	Port2 Input Data16	No	Ports 1 to 4 only	Ports 1 to 8
	...							
Port 8 Input Data	Port 8 Input Data 01	Same as for Port 1 Input Data.	ARRAY [0..1] OF BYTE	0000 to FFFF hex	Port8 Input Data 01	Yes	Ports 1 to 4 only	Ports 1 to 8
	...							
	Port 8 Input Data 16	Same as for Port 1 Input Data.	ARRAY [0..1] OF BYTE	0000 to FFFF hex	Port8 Input Data16	No	Ports 1 to 4 only	Ports 1 to 8

4-2-2 Output Data (from the Controller to the IO-Link Master Unit)

Digital Output Data to Non-IO-Link Devices

Data name (= object name)	Function	Data type	Value	I/O port name	Default I/O allocation	IO-Link Master Unit	
						NX	GX
Digital Output Data	Digital output data to non-IO-Link devices in SIO (DO) Mode.	WORD *1	0000 to FFFF hex	Digital Output Data	No		
Port 1 Digital Output Bit	The digital output signal to the port.	BOOL	FALSE, TRUE	Port1 Digital Output Bit		Yes	Yes
Port 2 Digital Output Bit	Same as above.	BOOL	Same as above.	Port2 Digital Output Bit		Yes	Yes
Port 3 Digital Output Bit	Same as above.	BOOL	Same as above.	Port3 Digital Output Bit		Yes	Yes
Port 4 Digital Output Bit	Same as above.	BOOL	Same as above.	Port4 Digital Output Bit		Yes	Yes
Port 5 Digital Output Bit	Same as above.	BOOL	Same as above.	Port5 Digital Output Bit		No	Yes
Port 6 Digital Output Bit	Same as above.	BOOL	Same as above.	Port6 Digital Output Bit		No	Yes
Port 7 Digital Output Bit	Same as above.	BOOL	Same as above.	Port7 Digital Output Bit		No	Yes
Port 8 Digital Output Bit	Same as above.	BOOL	Same as above.	Port8 Digital Output Bit		No	Yes

*1. When you use an NJ/NX-series CPU Unit or NY-series Industrial PC as the controller, you can create a UNION variable to enable specifying both WORD and BOOL (bit) data.

Process Output Data to IO-Link Devices

Data name (= object name)		Function	Data type	Value	I/O port name	Default I/O allocation	IO-Link Master Unit	
							NX	GX
Port 1 Output Data	Port 1 Output Data 01	This is output data from the IO-Link device in IO-Link Mode. The format is defined by the IO-Link device. You can allocate data with a different data size to each port.	ARRAY [0..1] OF BYTE	0000 to FFFF hex	Port1 Output Data 01	Yes	Ports 1 to 4 only	Ports 1 to 8
	Port 1 Output Data 02	Same as for Port 1 Output Data 01.	ARRAY [0..1] OF BYTE	0000 to FFFF hex	Port1 Output Data 02	No	Ports 1 to 4 only	Ports 1 to 8
	...							
	Port 1 Output Data 16	Same as for Port 1 Output Data 01.	ARRAY [0..1] OF BYTE	0000 to FFFF hex	Port1 Output Data 16	No	Ports 1 to 4 only	Ports 1 to 8
Port 2 Output Data	Port 2 Output Data 01	Same as for Port 1 Output Data.	ARRAY [0..1] OF BYTE	0000 to FFFF hex	Port2 Output Data 01	Yes	Ports 1 to 4 only	Ports 1 to 8
	...							
	Port 2 Output Data 16	Same as for Port 1 Output Data.	ARRAY [0..1] OF BYTE	0000 to FFFF hex	Port2 Output Data 16	No	Ports 1 to 4 only	Ports 1 to 8
...	...							
Port 8 Output Data	Port 8 Output Data 01	Same as for Port 1 Output Data.	ARRAY [0..1] OF BYTE	0000 to FFFF hex	Port8 Output Data 01	Yes	Ports 1 to 4 only	Ports 1 to 8
	...							
	Port 8 Output Data 16	Same as for Port 1 Output Data.	ARRAY [0..1] OF BYTE	0000 to FFFF hex	Port8 Output Data 16	No	Ports 1 to 4 only	Ports 1 to 8

4-3 I/O Allocation Settings

This section describes the I/O allocation settings of I/O data in the controller.

4-3-1 What Are I/O Allocation Settings?

Use the IO-Link allocation settings to allocate the I/O data in the controller to enable cyclic communications.

Settings are made from the following locations in the IO-Link Master Unit Configuration Tool.

- NX-type IO-Link Master Unit: Edit I/O Allocation Settings Window
- GX-type IO-Link Master Unit: Edit PDO Map Settings Window

4-3-2 When Are I/O Allocation Settings Required?

If you do not use the default I/O allocations, set the I/O allocations for the IO-Link Master Unit from the IO-Link Master Unit Configuration Tool.

I/O allocations are required in the following situations.

- If the IO-Link process input data or the IO-Link process output data from any connected IO-Link device exceeds 2 bytes
- To exclude unused data (objects) from IO-Link allocations to minimize the size of I/O data
- To make the I/O allocations of the IO-Link Master Unit with unit version 1.1 or later the same as default values of an IO-Link Master Unit with unit version 1.0



Precautions for Correct Use

Observe the following precautions when you allocate I/O for NX-type IO-Link Master Units or GX-type IO-Link Master Units.

- Set the IO-Link input allocation data size in the IO-Link Master Unit to a value that is equal to or greater than the IO-Link input data size input to each IO-Link Master Unit. If you set a value that is less than the IO-Link input data size of the IO-Link device, only the set size of data will be input to the controller.
- Set the IO-Link output allocation data size in the IO-Link Master Unit to a value that is equal to or greater than the IO-Link output data size output from the IO-Link Master Unit. If you set a value that is less than the output data size of the IO-Link Master Units, an error will occur.

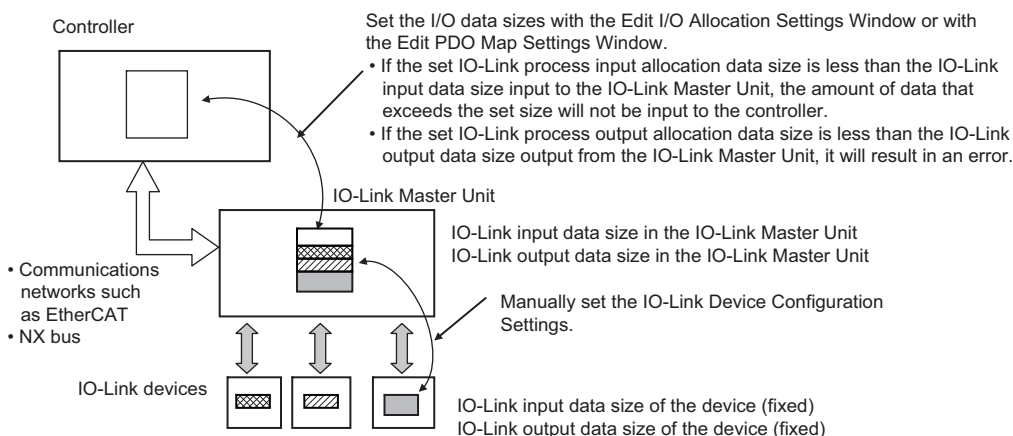



Version Information

The default values of I/O allocations differ between the IO-Link Master Unit with unit version 1.0 and one with unit version 1.1 or later. For details on I/O allocations, refer to *4-1-2 Type of I/O Data* on page 4-2.

4-3-3 I/O Allocation Setting Method

Settings are made from the following locations in the IO-Link Master Unit Configuration Tool.

- NX-type IO-Link Master Unit: Edit I/O Allocation Settings Window
- GX-type IO-Link Master Unit: Edit PDO Map Settings Window

For the operating procedure, refer to *8-2-3 Changing I/O Data Sizes in the IO-Link Master Unit* on page 8-8.



Precautions for Correct Use

Allocate the process input data from and process output data to IO-Link devices consecutively starting from data 01. A setting error will occur if you skip data or the data is not consecutive and in order.

4-4 Specifying I/O Data in the User Program

This section explains how to specify I/O data in the IO-Link Master Unit from the user program.

The methods that you can use to specify I/O data depend on the connection destination of the IO-Link Master Unit.

4-4-1 Controller Communications Using EtherCAT (NX-type IO-Link Master Unit or GX-type IO-Link Master Unit)

Use the following procedure to specify I/O data in the user program.

- 1** Register the IO-Link Master Unit as an EtherCAT slave in the EtherCAT Configuration Settings of the Sysmac Studio.
The I/O ports for the I/O data in the IO-Link Master Unit are automatically displayed in the I/O Map.
- 2** Use the I/O Map of the Sysmac Studio to assign device variables to the I/O ports of the IO-Link Master Unit.
- 3** Use the device variables in the user program.



Additional Information

Device variables are used to access data in slaves or Units.

A device variable accesses data through a port that acts as an interface to an external device. This port is called an I/O port.

4-4-2 Controller Communications Using EtherNet/IP (NX-type IO-Link Master Unit)

Regardless of the model of the NX Unit, I/O data is mapped in the I/O data block of the EtherNet/IP Coupler Unit in the order in which the NX Unit is connected to the EtherNet/IP Coupler Unit.

Tags are assigned in this I/O data block. This lets you specify I/O data in the IO-Link Master Unit.

For details, refer to the *NX-series EtherNet/IP Coupler Unit User's Manual* (Cat. No. W536).

4-4-3 Controller Communications Using NX bus (NX-type IO-Link Master Unit)

- 1** Register the IO-Link Master Unit as an NX Unit in the CPU and Expansion Rack Configuration settings on the Sysmac Studio.
- 2** Use the I/O Map of the Sysmac Studio to assign device variables to the I/O ports of the IO-Link Master Unit.
- 3** Use the device variables in the user program.

5

Status and Software Switches Other Than for I/O Data

This section describes IO-Link System status other than the status of I/O data.

5-1 Overview of Status and Software Switches Other Than for I/O Data and Their Types	5-2
5-2 Details on Status and Software Switches Other Than for I/O Data	5-3

5-1 Overview of Status and Software Switches Other Than for I/O Data and Their Types

This section describes the status and software switches other than for I/O data.

The IO-Link Master Unit contains status and software switches that are not for I/O data (i.e., the data transferred in cyclic communications), but rather the data transferred in message communications.

The types of status and software switches other than for I/O data are given below.

● Status

- Lost Frames ^{*1}
- IO-Link Device Information Area

*1. Indicates the IO-Link total communications lost frames.

● Software Switches

- Clear Backup Data Command

You can read and write status and software switches other than for I/O data with communications instructions from the controller.

For details on communications instructions, refer to *6-3 Message Communications* on page 6-8.



Precautions for Correct Use

When you use the EtherNet/IP Coupler Unit with unit version 1.1 or earlier, message communications cannot be executed to the IO-Link Master Unit so you cannot read or write the status and software switches other than for I/O data. Use the EtherNet/IP Coupler Unit with unit version 1.2 or later to read or write the relevant data.

5-2 Details on Status and Software Switches Other Than for I/O Data

This section gives details on the status and software switches other than for I/O data.

Status and software switches are given in the following tables. Monitor or set them for each port.

None of these status and software switches are backed up or restored.

Refer to the list of objects in the user's manual for the IO-Link Master Units for the details on objects.

Status

Setting (= object name)	Description	Default	Setting range	NX-type IO-Link Master Unit		GX-type IO-Link Master Unit	
				Index	Sub-index	Index	Sub-index
Lost Frames* ¹	This is the total number of lost frames of IO-Link cyclic communications for the ports. If you write a value, totaling the number of retries starts from the written value. Write 00 hex to reset the total.	00 hex	00 to FF hex* ²	500E hex	01 to 04 hex	A0*0 hex* ³	02 hex

Setting (= object name)		Description	Default	Setting range	NX-type IO-Link Master Unit		GX-type IO-Link Master Unit	
					Index	Subindex	Index	Subindex
IO-Link Device Information Area ^{*4}	Device ID	The type of IO-Link device.	00000000 hex	00000000 to FFFFFFFF hex	500A to 500D hex	01 hex	90*0 hex ^{*3}	04 hex
	Vendor ID	The vendor ID of the IO-Link device.	0000 hex	0000 to FFFF hex		02 hex		05 hex
	Serial Number	The serial number of the IO-Link device.	---	16 characters max.		05 hex	90*1 hex ^{*3}	None
	IO-Link Revision	The IO-Link revision of the IO-Link device.	00 hex	00 to FF hex		06 hex	90*0 hex ^{*3}	20 hex
	IO-Link Cycle Time	This is the cycle time of IO-Link communications with the IO-Link devices.	00 hex	00 to FF hex		08 hex		22 hex
	Process Data In Length	The size (in bytes) of the process input data from the IO-Link device.	00 hex	00 to FF hex		09 hex		24 hex
	Process Data Out Length	The size (in bytes) of the process output data to the IO-Link device.	00 hex	00 to FF hex		0A hex		25 hex
	Vendor Name of the Last Connected IO-Link Device ^{*5}	Vendor name of the last-connected IO-Link device ^{*6}	---	64 characters max.		0C hex	80*2 hex ^{*3}	None
	Product Name of the Last Connected IO-Link Device ^{*5}	Product name of the last-connected IO-Link device ^{*6}	---	64 characters max.		0D hex	80*3 hex ^{*3}	None
	Vendor Name ^{*5}	Vendor name of the IO-Link device ^{*7}	---	64 characters max.		0E hex	90*2 hex ^{*3}	None
	Product Name ^{*5}	Product name of the IO-Link device ^{*7}	---	64 characters max.		0F hex	90*3 hex ^{*3}	None

*1. Indicates the IO-Link total communications lost frames.

*2. When the maximum value of FF hex is reached, totaling stops at FF hex, and no further lost frames are counted.

*3. Replace * with a number between 0 and 7.

*4. If verification is enabled in the IO-Link Device Verification Setting and a verification error occurs for the IO-Link version, only the IO-Link version is given in the IO-Link Device Information Area.

If verification is enabled in the IO-Link Device Verification Setting and verification errors occur for the device ID, vendor ID, and serial number, device ID, vendor ID, and IO-Link version are given in the IO-Link Device Information Area. The serial number is not given. To obtain the serial number, disable verification in the IO-Link Device Verification Setting and read the IO-Link Device Information Area.

*5. These objects are supported for the IO-Link Master Unit with unit version 1.1 or later.

*6. When an IO-Link device is connected, the vendor name and product name are written. Even if the IO-Link device is disconnected, its vendor name and product name are retained. This enables you to check the vendor name and product name of the connected IO-Link device before replacement if you replace an IO-Link device.

*7. When an IO-Link device is connected, the vendor name and product name are written. The vendor name and product name of a currently connected IO-Link device can be checked. When the IO-Link device is disconnected, 64 zeros (0) are stored. With the ASCII code, for example, this will be 64 NUL.

Software Switches

Setting (= object name)		Meaning	Default	Setting range	NX-type IO-Link Master Unit		GX-type IO-Link Master Unit	
					Index	Subindex	Index	Subindex
Clear Backup Data Command	Command	This command clears the backup data in the IO-Link Master Unit.	00 hex	00 to 01 hex The backup data is cleared when the command changes from 00 hex to 01 hex.	5018 hex	01 hex	3209 hex	01 hex
	Result	This is the result of clearing the backup data.	0000 hex	0000 to FFFF hex 0000 hex: Backup completed or not executed. 0001 hex: Backup failed. FFFF hex: Backup in progress.		02 hex		02 hex

6

IO-Link System Communications

This section describes IO-Link System communications.

6-1	Types and Startup of Communications for IO-Link Systems	6-2
6-1-1	Types of Communications for IO-Link Systems	6-2
6-1-2	Starting Communications between the Controller and the IO-Link Master ...	6-2
6-1-3	Starting IO-Link Communications between the IO-Link Master Unit and the IO-Link Devices	6-3
6-2	Cyclic Communications	6-5
6-2-1	Overview of Cyclic Communications	6-5
6-2-2	Start Timing of Cyclic Communications in IO-Link Communications	6-6
6-2-3	Writing a Program for Cyclic Communications for IO-Link Communications	6-6
6-2-4	Stopping IO-Link Cyclic Communications	6-7
6-2-5	Operation When an IO-Link Device Is Disconnected	6-7
6-2-6	Cycle Communications Response Performance	6-7
6-3	Message Communications	6-8
6-3-1	Introduction to Message Communications	6-8
6-3-2	Message Communications with the IO-Link Master	6-9
6-3-3	Message Communications with IO-Link Devices	6-12

6-1 Types and Startup of Communications for IO-Link Systems

This section describes the types of communications in the IO-Link Systems and also how to start the communications.

6-1-1 Types of Communications for IO-Link Systems

There are the following two types of communications in an IO-Link System.

- Communications between the controller and the IO-Link master
- IO-Link communications between the IO-Link master and the IO-Link devices

Both cyclic communications and message communications can be used for these.

6-1-2 Starting Communications between the Controller and the IO-Link Master

The methods of starting communications between the controller and the IO-Link Master Unit depend on the controller and communications network in the system configuration. Refer to the user's manual for the connected controller or Communications Coupler Unit for details.

6-1-3 Starting IO-Link Communications between the IO-Link Master Unit and the IO-Link Devices

IO-Link communications start automatically if the following three conditions are met.

- The I/O cables are connected.
- The Unit power supply to the IO-Link Master Unit is ON.
- The I/O power supply to the IO-Link Master Unit is ON.

The above three power supplies can be turned ON in any order.

However, if you are using the connected device verification function and the registered configuration settings of the IO-Link devices do not match the actual configuration settings of the IO-Link devices, IO-Link communications for those ports will not start.

The method of starting IO-Link communications differs as described below, depending on whether or not you verify the connected device configuration.



Precautions for Correct Use

- If you do not enable verification with the IO-Link Device Verification Setting, errors will not be detected for an IO-Link System even if unwanted IO-Link devices are connected. We therefore recommend that you enable verification with the IO-Link Device Verification Setting.
- Connected devices can be verified for only IO-Link devices. If a non-IO-Link device is connected when the connected device verification function is enabled and the communications mode is set to IO-Link Mode, an IO-Link communications error will occur.

Preparations When Verifying the Connected Device Configuration

This function is used to verify the connection configuration of IO-Link devices that are connected to the IO-Link Master Unit against the registered IO-Link Device Configuration Settings. If the verification results indicate that a matching IO-Link device is connected, IO-Link communications start automatically. If the verification results indicate that a non-matching IO-Link device is connected, IO-Link communications stop.

Set the configuration of IO-Link devices to use for verification from the IO-Link Master Unit Configuration Tool.

Refer to *7-2 Connected Device Verification* on page 7-6 for the setting procedure.

Preparations When Not Verifying the Connected Device Configuration

If the connection configuration of IO-Link devices is not verified against the registered IO-Link Device Configuration Settings, IO-Link communications will be started according to the specifications of the connected IO-Link devices.

6-2 Cyclic Communications

This section describes cyclic communications for IO-Link Systems.

6-2-1 Overview of Cyclic Communications

Cyclic communications for IO-Link Systems consist of the following two types of communications.

(a) Cyclic Communications for IO-Link Communications

The IO-Link Master Unit acts as an IO-Link communications master and shares the I/O data (process data)^{*1} of the IO-Link devices with the IO-Link devices in a cycle.

(b) Cyclic Communications with Controller

The IO-Link Master Unit acts as a slave of the controller and simultaneously shares I/O data that was shared in the above IO-Link communications with the controller along with its own status and digital input or digital output values.

*1. For the I/O data (process data) of OMRON IO-Link devices, refer to the *Index List* of the IO-Link devices in *Related Manuals* on page 21.

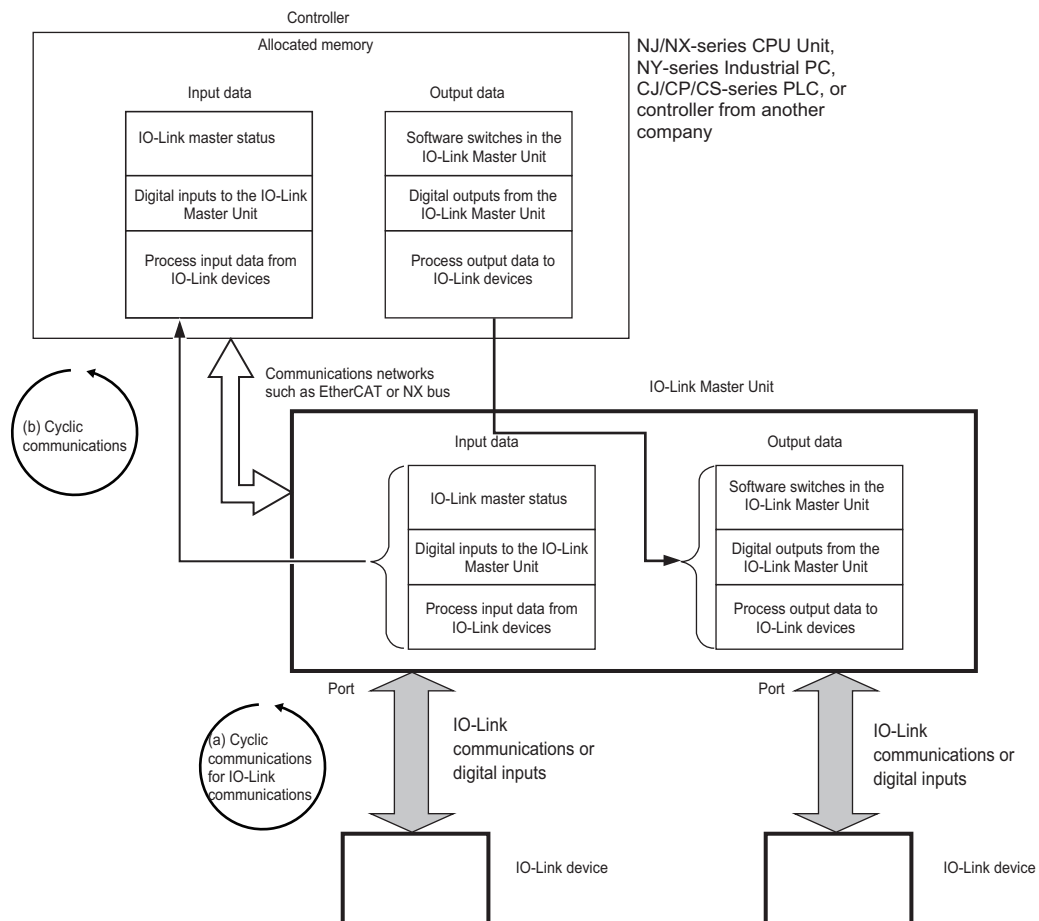

Type of communications in the IO-Link System	Communications between the controller and the IO-Link master	IO-Link communications between the IO-Link master and the IO-Link devices
Cyclic communications	<ul style="list-style-type: none"> • For each communications network: Communications with each communications network • For NX bus: I/O data communications 	<ul style="list-style-type: none"> • IO-Link cyclic communications: Cyclic communications between the IO-Link Master Unit and the IO-Link devices. • Cyclic communications between the controller and the IO-Link Master Unit are asynchronous. • These communications are automatically executed when the Unit power supply and the I/O power supply are turned ON.

6-2-2 Start Timing of Cyclic Communications in IO-Link Communications

Cyclic communications start automatically when IO-Link communications start.

Refer to *6-1-3 Starting IO-Link Communications between the IO-Link Master Unit and the IO-Link Devices* on page 6-3.

Cyclic communications are not related to the status of communications between the controller and the IO-Link Master Unit.

6-2-3 Writing a Program for Cyclic Communications for IO-Link Communications

Write the program for cyclic communications so that input and output processes with the IO-Link Master Unit are executed when the following conditions are met.

● Using the IO-Link Process Input Data in the User Program

Use the IO-Link process input data when the Input Data Enabled Flag for the I/O data is TRUE.



Precautions for Correct Use

- If an error occurs in IO-Link communications, the IO-Link process input data in the IO-Link Master Unit turns OFF. To prevent malfunctions, write the user program so that IO-Link data processing is not performed when the Input Data Enabled Flag is FALSE.
- Also, if an error occurs in IO-Link communications, the IO-Link process output data sends an Output Data Disable internal command to the IO-Link devices. In the IO-Link devices, make settings to ensure safe-side operation when the output data is disabled.
- The Input Data Enabled Flag is FALSE when a non-IO-Link sensor is connected in IO-Link Mode. Write the user program so that IO-Link data processing is not performed when the Input Data Enabled Flag is FALSE (including for a connection to a non-IO-Link device).
- You must use the TRUE status of the Input Data Enabled Flag in the I/O data as a condition for processing the IO-Link process input data in IO-Link Mode in the user program of the controller.

6-2-4 Stopping IO-Link Cyclic Communications

You can specify that IO-Link cyclic communications are to stop for each port.

- 1** Set the communications mode setting for each port to *Disable Port*.
- 2** Restart*¹ the IO-Link Master Unit or cycle the Unit power supply.

*1. You can restart only NX-type IO-Link Master Units. You must restart the entire Slave Terminal. With a GX-type IO-Link Master Unit, it is necessary to cycle the power supply.

6-2-5 Operation When an IO-Link Device Is Disconnected

The operation that occurs when an IO-Link device is disconnected from a port is the same as when an I/O cable is not connected or broken. An IO-Link communications error will occur.

- IO-Link devices operate as described in the following table when an IO-Link communications error occurs.

Communications mode	IO-Link Process Input Data in the IO-Link Master Unit	Outputs from the IO-Link devices
IO-Link Mode	<p>The values of the input data immediately before the IO-Link communications error occurred are retained.</p> <p>Write the program to use the process input data only when the Input Data Enabled Flag is TRUE.</p>	The status of the outputs depends on the specifications of the IO-Link devices.

6-2-6 Cycle Communications Response Performance

Refer to the I/O response performance of the individual IO-Link Master Units for information on the response performance of cyclic communications.

6-3 Message Communications

This section describes message communications for IO-Link Systems.

6-3-1 Introduction to Message Communications

Message communications are used in an IO-Link System to access data from the controller when necessary.

Communications with the IO-Link Master Unit and communications with the IO-Link devices through the IO-Link Master Unit are possible.

- For communications with the IO-Link Master Unit, data other than the I/O data objects in the IO-Link Master Unit can be accessed.
- For communications with the IO-Link devices, all object data in the IO-Link devices can be accessed.

Type of communications in the IO-Link System	Communications between the controller and the IO-Link master	IO-Link communications between the IO-Link master and the IO-Link devices
Message communications	<ul style="list-style-type: none"> • Message communications for the IO-Link Master Unit • Message communications are executed by sending commands to the IO-Link Master Unit with communications instructions from the controller. 	<ul style="list-style-type: none"> • Message communications can be performed with the IO-Link devices. IO-Link communications are executed through the IO-Link Master Unit. • Message communications are executed by sending commands to the IO-Link devices with communications instructions from the controller.
Target data	Data other than I/O data in the objects in the IO-Link Master Unit	All objects in the IO-Link devices

6-3-2 Message Communications with the IO-Link Master

This section describes message communications for the IO-Link Master Unit from OMRON Controllers.

For details on the communications instructions of message communications from another company's controller, refer to the message communications with each system configuration in *A-1 Other System Configurations* on page A-2. For the condition for message communications, refer to *Conditions for Message Communications with the IO-Link Master Unit* on page 6-9.

EtherCAT Communications or NX Bus Communications

For an NX-type IO-Link Master Unit, message communications are performed by using instructions to read or write the NX objects in the Master Unit.

For a GX-type IO-Link Master Unit, message communications are performed by using SDO communications instructions to read/write CoE objects in the EtherCAT slave.

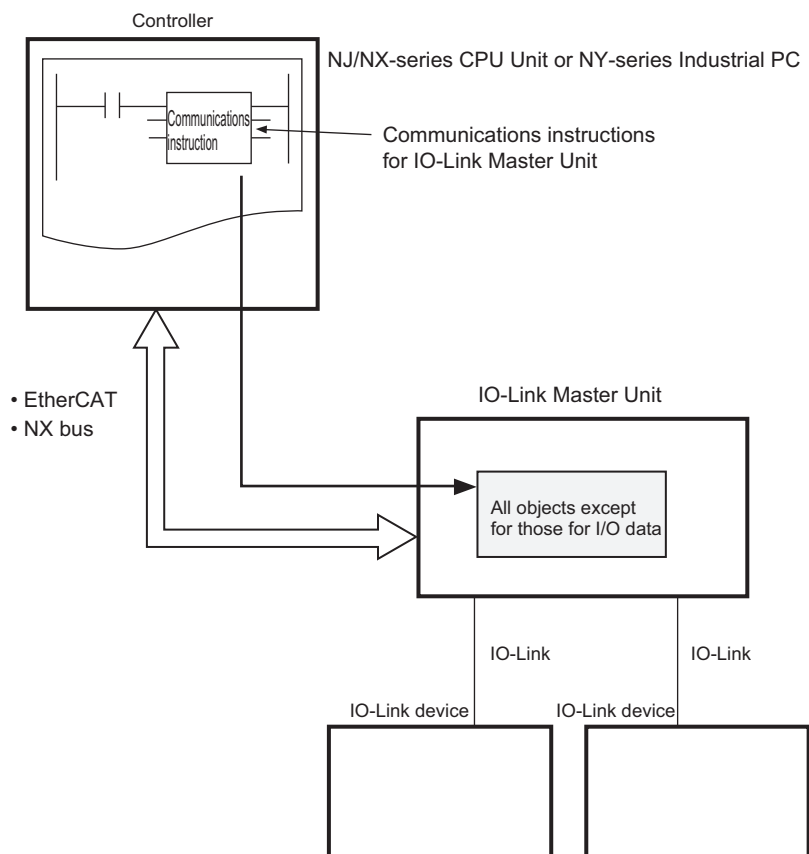

● Conditions for Message Communications with the IO-Link Master Unit

The following conditions must be met.

- Communications must be established between the controller and the IO-Link Master Unit.



Precautions for Correct Use

The IO-Link Master Unit can receive one message at a time. When multiple messages are issued, an error is returned.

● Communications Instructions for IO-Link Master Unit

Use the following read instructions and write instructions for the communications instructions to the IO-Link Master Unit.

Type of IO-Link Master Units	Read instructions	Write instructions
NX-type	NX_ReadObj (Read NX Unit Object) instruction	NX_WriteObj (Write NX Unit Object) instruction
GX-type	EC_CoESDORead (Read EtherCAT CoE SDO) instruction	EC_CoESDOWrite (Write EtherCAT CoE SDO) instruction

The controller can access the following objects of the IO-Link Master Unit using the above communications instructions.

- For NX-type: NX objects
- For GX-type: CoE objects

For details of the communications instructions, refer to the instructions reference manual for the connected CPU Unit or Industrial PC.

EtherNet/IP Communications

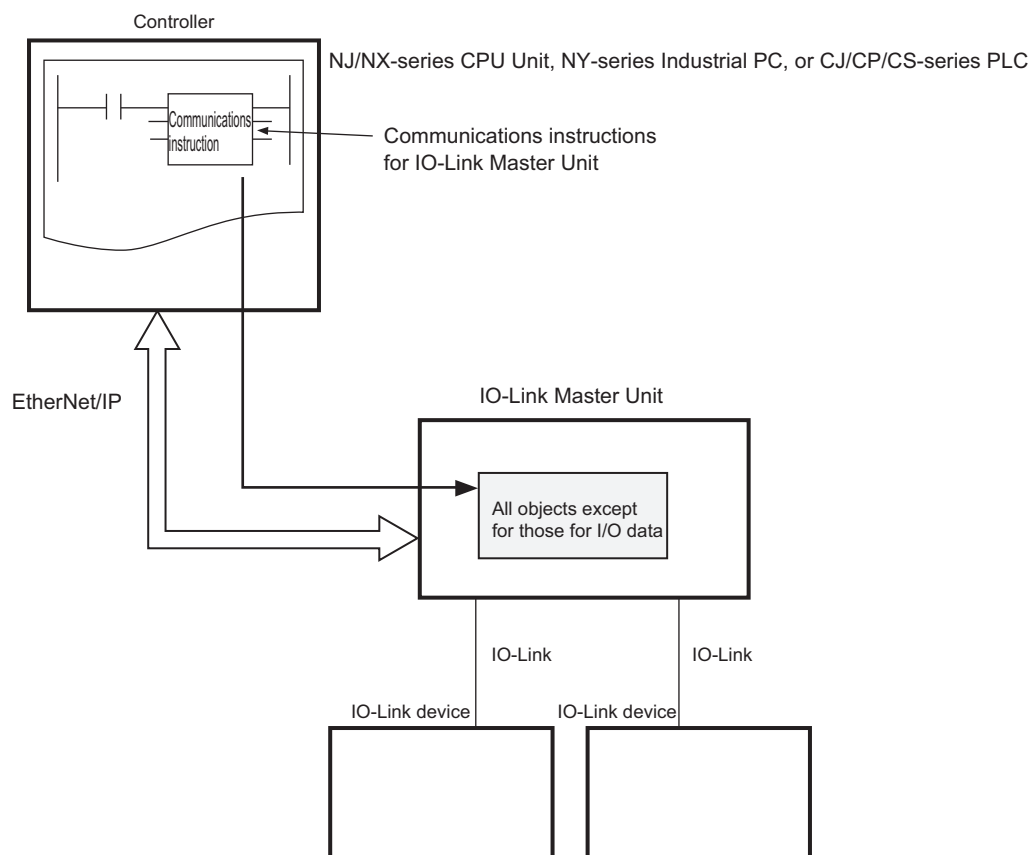

Precautions for Correct Use

When you connect an NX-type IO-Link Master Unit to an EtherNet/IP Coupler Unit and perform message communications with the IO-Link Master Unit from the controller, use the EtherNet/IP Coupler Unit with unit version 1.2 or later.

For unit version 1.1 or earlier, the message communications are not available.

● Conditions for Message Communications with the IO-Link Master Unit

It is the same as communications with EtherCAT or NX bus. Refer to *Conditions for Message Communications with the IO-Link Master Unit* on page 6-9 for details.

● Communications Instructions for IO-Link Master Unit

Use the following read instructions and write instructions for each controller for message communications to the IO-Link Master Unit.

a) Using an NJ/NX-series CPU Unit or NY-series Industrial PC as the Controller

Type of IO-Link Master Units	Read instructions	Write instructions
NX-type	<ul style="list-style-type: none"> CIPSend (Send Explicit Message) instruction CIPUCMMSend (Send Explicit Message) instruction 	

The controller can access the relevant NX objects of the IO-Link Master Unit using the CIP object (i.e., Read NX object (33 hex) or Write NX object (34 hex)) of the EtherNet/IP Coupler Unit.

For details on how to access the relevant objects of the IO-Link Master Unit, refer to the *NX-series EtherNet/IP Coupler Unit User's Manual* (Cat. No. W536).

For details of the communications instructions, refer to the instructions reference manual for the connected CPU Unit or Industrial PC.

b) Using a CJ/CP/CS-series PLC as the Controller

Type of IO-Link Master Units	Read instructions	Write instructions
NX-type	CMND (EXPLICIT MESSAGE SEND) instruction (FINS 2810)	

The controller can access the relevant NX objects of the IO-Link Master Unit using the CIP object (i.e., Read NX object (33 hex) or Write NX object (34 hex)) of the EtherNet/IP Coupler Unit.

For details on how to access the relevant objects of the IO-Link Master Unit, refer to the *NX-series EtherNet/IP Coupler Unit User's Manual* (Cat. No. W536).

Refer to the *CS/CJ/NSJ Series Instructions Reference Manual* (Cat. No. W474) for details on the communications instructions.

6-3-3 Message Communications with IO-Link Devices

This section describes message communications for the IO-Link devices from OMRON Controllers. These communications are performed with instructions that read/write the IO-Link device objects*¹ in the IO-Link devices.

*1. For the I/O data (process data) of OMRON IO-Link devices, refer to the *Index List* of the IO-Link devices in *Related Manuals* on page 21.

For details on the communications instructions of message communications from another company's controller, refer to the message communications with each system configuration in *A-1 Other System Configurations* on page A-2. For the condition for message communications, refer to *Conditions for Message Communications with IO-Link Devices* on page 6-12.

EtherCAT Communications or NX Bus Communications

Communications conditions, communications instructions and program examples for message communications with the IO-Link devices are described below.

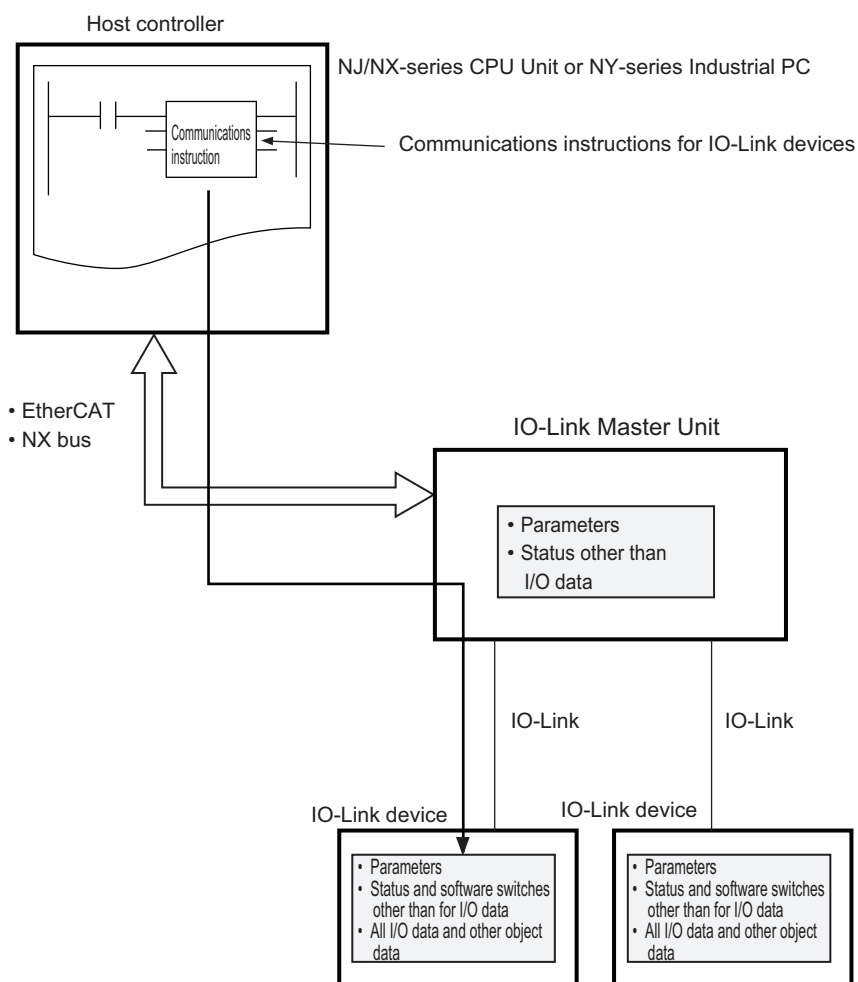

● Conditions for Message Communications with IO-Link Devices

The following conditions must be met.

- Communications must be established between the controller and the IO-Link Master Unit.
- Communications must be established between the IO-Link Master Unit and the IO-Link devices.
- The communications mode must be IO-Link Mode.

Note If a port is disabled or in SIO (DI) Mode or SIO (DO) Mode, communications instructions to the IO-Link device will result in an error.

● **Communications Instructions for IO-Link Devices and Programming Example**

There are the following read instructions and write instructions for communications instructions to IO-Link devices.

The following programming example is for communications with EtherCAT.

a) Read IO-Link Device Object (IOL_ReadObj) Instruction

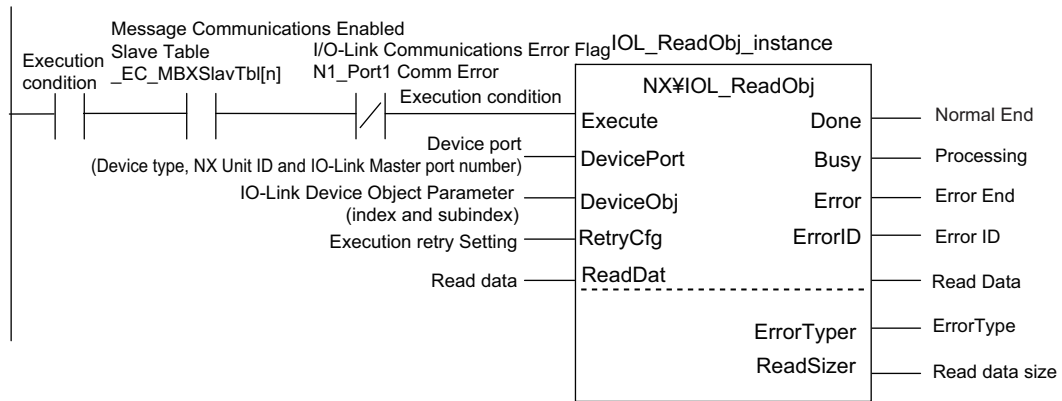

b) Write IO-Link Device Object (IOL_WriteObj) Instruction

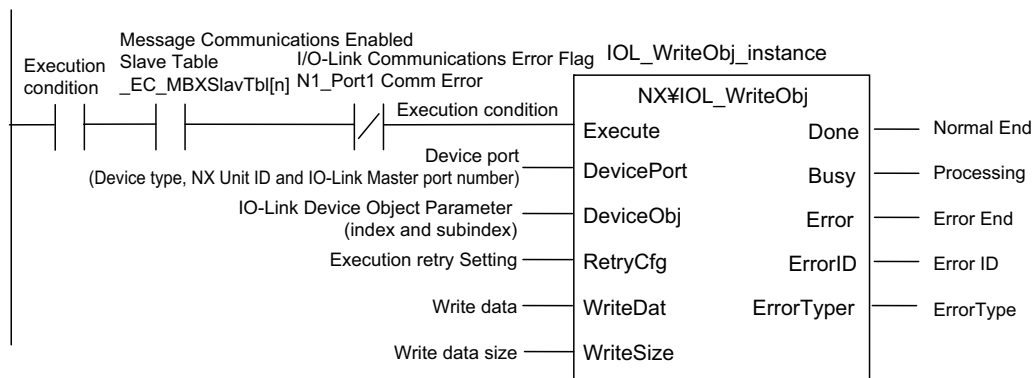

For details of the communications instructions, refer to the instructions reference manual for the connected NJ/NX-series CPU Unit or Industrial PC.

The following conditions in the above programming example must be met to execute communications instructions addressed to IO-Link devices.

- Executing message communications must be possible for the controller.
- There must be no errors indicated in the I/O Port Error Status, e.g., the IO-Link Communications Error Flag must be FALSE.

Example:

- The system-defined variable `_EC_MBXSlavTbl[i]` (Message Communications Enabled Slave Table) must be TRUE (communications are enabled)*1.
- The IO-Link Communications Error Flag must be FALSE (no communications errors).

*1. If the communications with the controller is the NX bus, use the following condition:

The system-defined variable `_NXB_UnitMsgActiveTbl[j]` (NX Unit Message Enabled Status) must be TRUE (message communications are enabled).

EtherNet/IP Communications

Communications conditions and communications instructions for message communications with the IO-Link devices are described below.

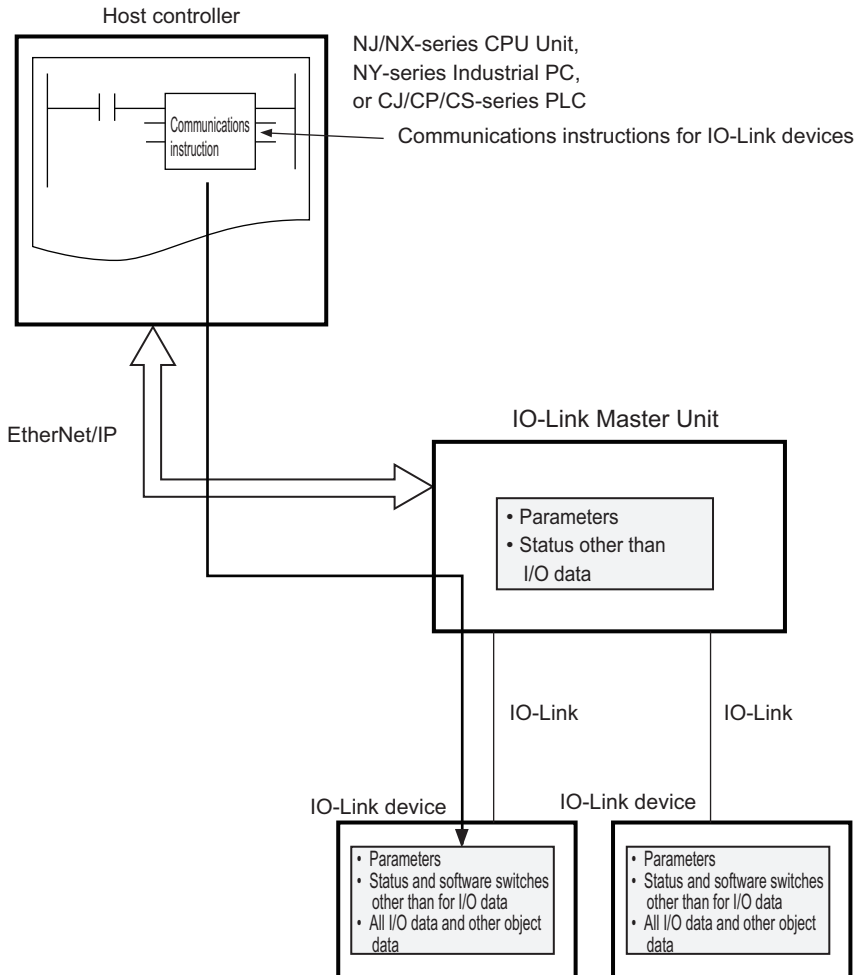

Precautions for Correct Use

When you connect an NX-type IO-Link Master Unit to an EtherNet/IP Coupler Unit and perform message communications with the IO-Link devices from the controller, use the EtherNet/IP Coupler Unit with unit version 1.2 or later.

For unit version 1.1 or earlier, the message communications are not available.

● Conditions for Message Communications with IO-Link Devices

It is the same as communications with EtherCAT or NX bus. Refer to *Message Communications with IO-Link Devices* on page 6-12 for details.

● Communications Instructions for IO-Link Devices

Use the following read instructions and write instructions for each controller for message communications to IO-Link devices.

a) Using an NJ/NX-series CPU Unit or NY-series Industrial PC as the Controller

Type of IO-Link Master Units	Read instructions	Write instructions
NX-type	<ul style="list-style-type: none"> CIPSend (Send Explicit Message) instruction CIPUCMMSend (Send Explicit Message) instruction 	

The controller can access the relevant NX objects of the IO-Link Master Unit using the CIP object (i.e., Read NX object (33 hex) or Write NX object (34 hex)) of the EtherNet/IP Coupler Unit.

For details on how to access the relevant objects of the IO-Link Master Unit, refer to the *NX-series EtherNet/IP Coupler Unit User's Manual* (Cat. No. W536) and *A-3 How to Access the IO-Link Devices with Message Communications* on page A-28.

For details of the communications instructions, refer to the instructions reference manual for the connected CPU Unit or Industrial PC.

b) Using a CJ/CP/CS-series PLC as the Controller

Type of IO-Link Master Units	Read instructions	Write instructions
NX-type	_IOL003_ReadObjEip (Read IO-Link Device Object) *1	_IOL004_WriteObjEip (Write IO-Link Device Object) *1

*1. This is the Smart FB.

For details on how to use this Smart FB, refer to the Smart FB Library Reference in Help of CX-Programmer.

7

Functions of IO-Link Master Units

This section describes the application functions of the IO-Link Master Units.

7-1	Communications Mode Settings	7-2
7-1-1	Functions Supported by Each Communications Mode	7-2
7-1-2	Setting Methods	7-4
7-2	Connected Device Verification	7-6
7-2-1	Overview	7-6
7-2-2	Setting Method	7-7
7-3	Load Rejection for Controller Communications Errors	7-9
7-3-1	Introduction	7-9
7-3-2	Setting Method	7-10
7-4	IO-Link Total Communications Lost Frames	7-11
7-4-1	Introduction	7-11
7-4-2	Application Method	7-11
7-5	Digital Input Filter	7-13
7-5-1	Introduction	7-13
7-5-2	Setting Method	7-13
7-6	Backup and Restoration of Parameter Settings in IO-Link Devices	7-14
7-6-1	Overview of Backup and Restore Operations	7-14
7-6-2	Backing Up Settings	7-15
7-6-3	Restoring Settings	7-20
7-6-4	Conditions for Backing Up and Restoring Parameter Settings When IO-Link Communications Start	7-21
7-6-5	Clearing Backup Data	7-21
7-6-6	Application Procedure	7-24
7-7	Digital Input Collection	7-25
7-7-1	Overview	7-25
7-7-2	Setting Method	7-27

7-1 Communications Mode Settings

This section describes the communications mode settings for the IO-Link ports.

7-1-1 Functions Supported by Each Communications Mode

If you use an OMRON IO-Link Master Unit, you can set the communications mode for each port to specify whether to perform IO-Link communications with the connected device or to use digital signal I/O with it.

The communications modes and the functions they support are given in the following table.

Yes: Can be used. No: Cannot be used.

Communications mode for the port	Description	Application	Usable functions				
			IO-Link communications		Digital inputs for pin 2	Digital signal inputs	Digital signal outputs
			Cyclic communications	Message communications			
IO-Link Mode	IO-Link communications are performed in this mode. Available baud rates include COM1, COM2, and COM3. When an IO-Link device enters the system, the IO-Link Master Unit automatically uses the baud rate of the device when it starts communications.	Select this mode to connect IO-Link devices to a port.	○	○	○	×	×
	You can input digital signals from IO-Link devices that support digital inputs for pin 2 while you perform IO-Link communications.	Use digital inputs for pin 2 when a faster response performance than the response performance of IO-Link communications is required. To use this function, the IO-Link device must also support digital inputs for pin 2.					
SIO (DI) Mode	This mode is for digital signal input only. The device functions as a digital input unit. IO-Link communications are not possible in this mode.	Select this mode to connect a non-IO-Link general-purpose ON/OFF sensor to a port.	×	×	×	○	×
SIO (DO) Mode	This mode is for digital signal output only. The device functions as a digital output unit. IO-Link communications are not possible in this mode.	Select this mode to connect a non-IO-Link general-purpose output device that operates on ON/OFF signals to a port.	×	×	×	×	○

Communications mode for the port	Description	Application	Usable functions				
			IO-Link communications		Digital inputs for pin 2	Digital signal inputs	Digital signal outputs
			Cyclic communications	Message communications			
Disable Port	A port is not used if this mode is set. IO-Link communications, digital signal input, and digital signal output are not performed in this mode.	Select this mode when not communicating with a device or performing I/O.	x	x	x	x	x

An example of setting each communications mode for each port will be described below.

Combination Examples:

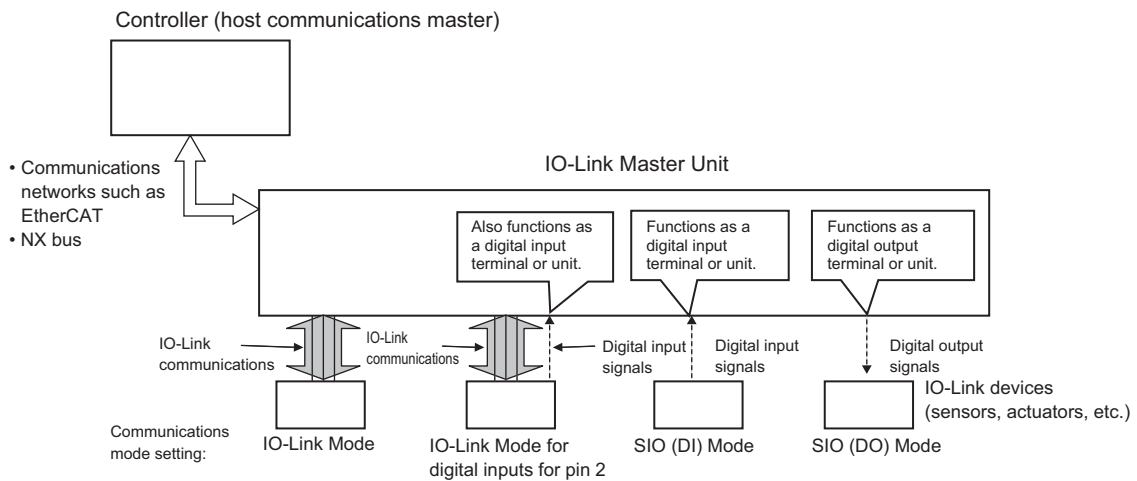



Additional Information

Digital Inputs for Pin 2

In IO-Link Mode, you can perform digital input (DI) with pin 2 while performing IO-Link communications. This is possible only for IO-Link devices that support digital inputs for pin 2.

In this case, the IO-Link Master Unit stores both IO-Link process input data from IO-Link communications and digital input (DI) data from pin 2. You can obtain digital input (DI) data faster than IO-Link process input data from IO-Link communications.

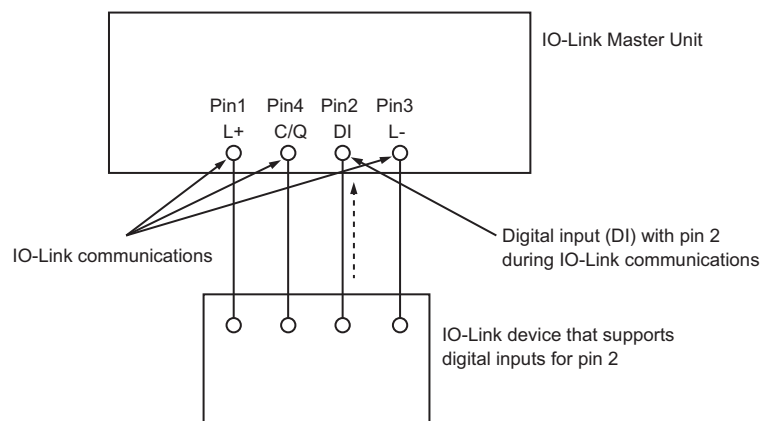

7-1-2 Setting Methods

Set the parameters to the following values from the IO-Link Master Unit Configuration Tool.

Use the Master Control Communications Mode Setting in the IO-Link Device Configuration Settings to make the setting.

Related Parameters

Setting (= object name)	Description	Default	Setting range
Master Control Communications Mode Setting	Sets the communications mode for a port.	03 hex: IO-Link Mode	00 to 03 hex 00 hex: Disable Port 01 hex: SIO (DI) Mode 02 hex: SIO (DO) Mode 03 hex: IO-Link Mode

Operations for Communications Modes of Connected Devices:

The operations for the types of devices that are connected to ports in each communications mode are given in the following table.

Communications mode for the port	Type of connected device		
	IO-Link device	Non-IO-Link sensor	Non-IO-Link actuator
IO-Link Mode	Operation is performed.	No operation is performed. The digital input turns OFF.	No operation is performed. The digital output becomes indefinite*1.
SIO (DI) Mode	The IO-Link devices operate in the Standard I/O Mode (SIO Mode) with conventional contact point input.	Operation is performed.	No operation is performed. The digital output turns OFF.
SIO (DO) Mode	No operation is performed. An error will not be detected.	No operation is performed. The digital input turns OFF.	Operation is performed.
Disable Port	No operation is performed.	No operation is performed. The digital input turns OFF.	No operation is performed. The digital output turns OFF.

*1. To continue the IO-Link communications startup operation, the output from non-IO-Link actuators turns ON and OFF in the internal signal data to establish IO-Link communications. Therefore, before you connect a non-IO-Link actuator, make sure that the communications mode is already set to SIO (DO) Mode.



Precautions for Correct Use

- The connected device verification function can be used only for IO-Link devices connected in IO-Link Mode.
- The Input Data Enabled Flag turns ON only when an IO-Link device having process input data is connected in IO-Link Mode.
- The following operation will occur if the communications mode setting does not match the connected device type.
 - a) If a non-IO-Link sensor is connected in IO-Link Mode, the sensor will operate but the IO-Link Master Unit will not read the ON/OFF signals. An error will not be detected. If connected device verification is enabled, an IO-Link communications error will occur.
 - b) If a non-IO-Link actuator is connected in IO-Link Mode, the actuator will perform unexpected operation. Master Unit will not read the ON/OFF signals. An error will not be detected. If connected device configuration verification is enabled, an IO-Link communications error will occur.
 - c) If an IO-Link device is connected in SIO (DO) Mode, the IO-Link device will not operate. An error will not be detected.
 - d) If an IO-Link device is connected in SIO (DI) Mode, the IO-Link device will operate in Standard I/O Mode (SIO Mode).
 - e) If a non-IO-Link actuator is connected in SIO (DI) Mode, the actuator will not operate.
 - f) If a non-IO-Link sensor is connected in SIO (DO) Mode, the sensor will not operate.



Precautions for Safe Use

Do not connect a non-IO-Link actuator to a port that is set to IO-Link Mode.

Depending on the internal operations (based on IO-Link specifications) to establish IO-Link communications, the actuator may unexpectedly and repeatedly turn ON and OFF in a short cycle.

7-2 Connected Device Verification

This section describes verification of the IO-Link device configuration in IO-Link Mode.

7-2-1 Overview

Connected device verification allows you to disable IO-Link communications with an IO-Link device that was not intentionally connected by the user. In IO-Link Mode, you can compare the configuration of the IO-Link devices that are actually connected against the registered IO-Link device connection configuration.

Connected device verification is possible only for IO-Link devices. The IO-Link device configuration settings information include the vendor ID, device ID, IO-Link version, and serial number.

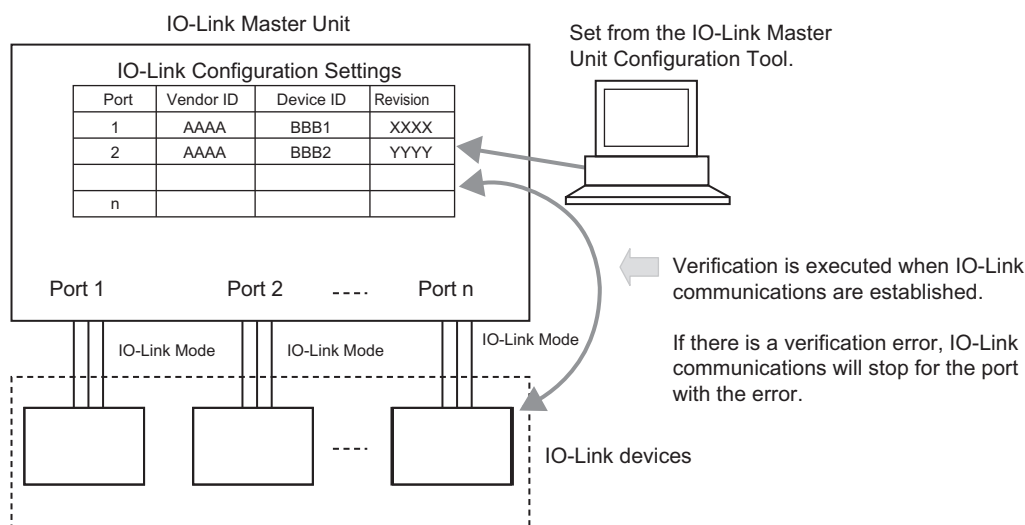

You can verify the vendor ID, device ID, serial number, and IO-Link revision of the connected IO-Link device for each port using either of the following two patterns.

- Vendor ID + Device ID + IO-Link revision
- Vendor ID + Device ID + Serial number + IO-Link revision

If an inconsistency is detected during verification, IO-Link communications (both cyclic communications and message communications) for the port with the inconsistency will stop, and a device configuration verification error will occur.

The overall operation of the IO-Link Master Unit will continue.

Connected devices can be verified only for IO-Link devices. If a non-IO-Link device is connected when the connected device verification function is enabled and the communications mode is set to IO-Link Mode, an IO-Link communications error will occur.

You do not necessarily have to make the IO-Link Device Configuration Settings for an IO-Link System. These settings are used to verify the actual device configuration when IO-Link communications start. These settings are not required unless you want to verify the configuration.

7-2-2 Setting Method

The setting procedure is shown below.

- 1** IO-Link device configuration settings information was created.
From the IO-Link Master Unit Configuration Tool, set the vendor ID, device ID, serial number, and IO-Link revision of the connected device for each port.
- 2** From the IO-Link Master Unit Configuration Tool, specify whether to verify the configuration and what specifically to verify in the IO-Link Device Verification Settings. For details, refer to *IO-Link Device Verification Setting* on page 7-8 in *Related Parameters* on page 7-8.
- 3** Connect the devices.
- 4** Turn ON the power supply to the IO-Link Master Unit and turn ON the I/O power supply.*1
*1. For an NX-type IO-Link Master Unit, this can also be done by restarting the IO-Link Master Unit. IO-Link communications will be established. When IO-Link communications are established, the ports will be verified.
- 5** If an inconsistency is detected during port verification, the Device Configuration Verification Error bit for the port will turn ON in the I/O data. IO-Link communications (both cyclic communications and message communications) for that port will stop. The E indicator will flash red for an NX-type IO-Link Master Unit, and the C/E indicator will flash red for a GX-type IO-Link Master Unit.

If a mismatch is detected for a port during verification, you can read the connected device information for that port from the CX-ConfiguratorFDT.

Disable checking with the IO-Link Device Verification Setting from the IO-Link Master Unit Configuration Tool before you read the actual configuration information from the CX-ConfiguratorFDT.



Precautions for Correct Use

- If you do not enable verification with the IO-Link Device Verification Setting, errors will not be detected for an IO-Link System even if unwanted IO-Link devices are connected. We therefore recommend that you enable verification with the IO-Link Device Verification Setting.
- If you use an IO-Link device that does not have a serial number, do not set the IO-Link Device Verification Setting to include verification of the serial number.

Applicable Communications Modes

IO-Link Mode

Connected Devices

IO-Link devices

Related Parameters

Set the parameters to the following values from the IO-Link Master Unit Configuration Tool.

● IO-Link Device Verification Setting

Setting (= object name)	Description	Default	Setting range
IO-Link Device Verification Setting	<p>This setting specifies whether to verify that the IO-Link devices actually connected to the ports match the IO-Link devices in the IO-Link Device Configuration Settings when IO-Link communications start.</p> <p>You can verify the vendor ID, device ID, IO-Link revision, and serial number of the connected IO-Link device for each port using either of the following two patterns.</p> <ul style="list-style-type: none"> • Vendor ID + Device ID + IO-Link revision • Vendor ID + Device ID + IO-Link revision + Serial number 	00 hex: Do not check.	00 to 02 hex 00 hex: Do not check. 01 hex: Verify the vendor ID, device ID, and IO-Link revision. 02 hex: Verify the vendor ID, device ID, IO-Link revision, and serial number.

● Manually Setting the IO-Link Device Configuration Settings

Setting (= object name)	Description	Default	Setting range	
IO-Link Device Configuration Settings	Device ID	The type of IO-Link device.	00000000 hex	00000000 to 00FFFFFF hex
	Vendor ID	The vendor ID of the IO-Link device.	00000000 hex	00000000 to 0000FFFF hex
	Serial No.	The serial number of the IO-Link device.	---	16 characters max.
	IO-Link Revision	The IO-Link revision of the IO-Link device.	00 hex	00 to FF hex

7-3 Load Rejection for Controller Communications Errors

This section describes the function that stops outputs from the IO-Link Master Unit when a controller communications error occurs.

7-3-1 Introduction

This function stops outputs from the IO-Link Master Unit to IO-Link devices and non-IO-Link devices when an error occurs in communications between the controller and the IO-Link Master Unit. When the Load Rejection Output Setting is enabled, the output operation described below is performed depending on the communications mode.

- In IO-Link Mode: The IO-Link Master Unit sends an Output Data Disable command to the IO-Link device. In this case, the operation to be performed when a failure occurs as a result of the operation when the output data set in the IO-Link device is disabled is determined. For details on the operations of the IO-Link devices upon receiving the Output Data Disabled command, refer to the manuals for your IO-Link devices.
- In SIO (DO) Mode: The digital output signals are turned OFF.

When the Load Rejection Output Setting is disabled, outputs from the IO-Link Master Unit to IO-Link devices and non-IO-Link devices are retained when an error occurs in communications between the controller and the IO-Link Master Unit.

Errors in the communications between the controller and the IO-Link Master Unit are either network communications errors or NX bus errors. For the NX-type IO-Link Master Unit, communications errors between the NX bus and the Communications Coupler Unit are also included in these errors.

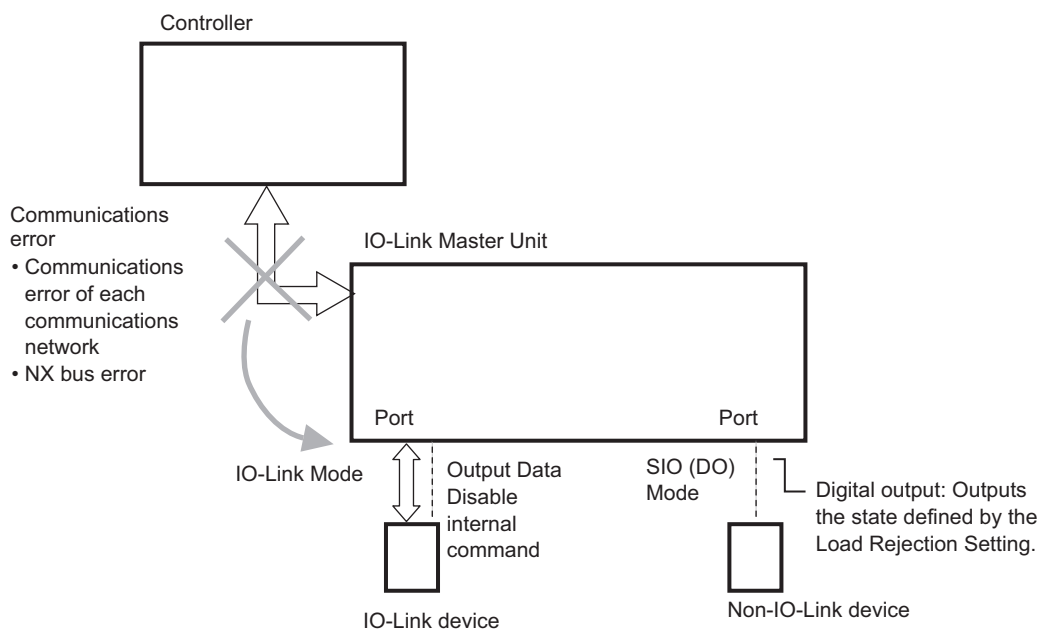

7-3-2 Setting Method

Use the IO-Link Master Unit Configuration Tool or communications instructions addressed to the IO-Link Master Unit to set the Load Rejection Output Setting for each port to enable load rejection. This setting will be enabled when the Unit power supply is turned ON.

● Output Operations from the IO-Link Master Unit by Load Rejection Output Settings

Communications mode	Load rejection output setting	Output Operations from the IO-Link Master Unit
IO-Link Mode	Load rejection enabled.	The IO-Link Master Unit sends an Output Data Disable command to the IO-Link device. For details on the operations of the IO-Link devices upon receiving the Output Data Disabled command, refer to the manuals for your IO-Link devices.
	Load rejection disabled.	IO-Link communications continue with the last output data received by the IO-Link Master Unit.
SIO (DO) Mode	Load rejection enabled.	The digital output is set to OFF.
	Load rejection disabled.	The last digital output value received from the controller by the IO-Link Master Unit is retained.

● Applicable Communications Modes

- IO-Link Mode
- SIO (DO) Mode

● Related Parameters

The target object that can be accessed with communications instructions is given below.

Setting (= object name)	Description	Default	Setting range	NX-type IO-Link Master Unit		GX-type IO-Link Master Unit	
				Index	Sub-index	Index	Sub-index
Load Rejection Output Setting	Enables load rejection to turn OFF outputs from the IO-Link Master Unit when an error occurs in controller communications. Specify whether to enable or disable this function for each port.	00 hex	00 to 01 hex 00 hex: Load rejection is ON 01 hex: Load rejection is OFF	5004 hex	01 to 04 hex	3204 hex	01 to 08 hex



Precautions for Correct Use

When you use the EtherNet/IP Coupler Unit with unit version 1.1 or earlier, you cannot use communications instructions for the IO-Link Master Unit. Connect the IO-Link Master Unit Configuration Tool to the peripheral USB port on the EtherNet/IP Coupler Unit and set the above parameter with the tool. Use the EtherNet/IP Coupler Unit with unit version 1.2 or later to use a communications instruction.

7-4 IO-Link Total Communications Lost Frames

This section describes the function that counts the total number of IO-Link communications lost frames in IO-Link Mode.

7-4-1 Introduction

In IO-Link Mode, you can read the total number of lost frames of IO-Link cyclic communications for each IO-Link port.

The IO-Link total communications lost frames information is used to diagnose the quality of IO-Link communications.

You can use it to diagnose the IO-Link communications line quality for the following:

- Confirming that an IO-Link device was correctly installed
- Finding the causes of communications errors that occur during normal operation

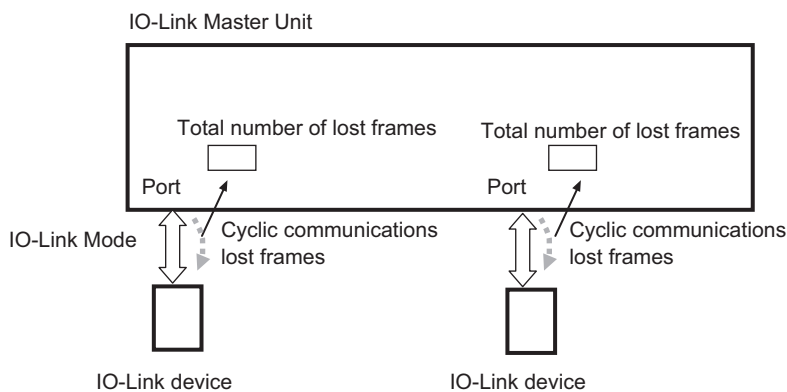

7-4-2 Application Method

Use the CX-ConfiguratorFDT or execute a communications instruction for the IO-Link Master Unit to read Lost Frames of the port.

You can read the total number of retries starting from when IO-Link communications start. When a value is written in Lost Frames, the total number of retries calculated from the written value can be read.

The range of the total is 00 to FF hex (0 to 255 decimal). The default is 00 hex.

If the total reaches FF hex, it stops at FF hex. In that case, you must execute a communication instruction for the IO-Link Master Unit to reset the default. If you execute a communications instruction for the IO-Link Master Unit to write a value, the totaling of the number of lost frames starts from that value.

This setting is cleared when the Unit power supply is turned OFF.

● Applicable Communications Modes

- IO-Link Mode

● Reading the Data with the CX-ConfiguratorFDT

Right-click the Master Unit in Network View and select diagnosis. The Diagnosis Tab Page for the IO-Link Master Unit is displayed.

The Lost Frames of each port are displayed on the following Diagnosis Tab Page for the IO-Link Master Unit.

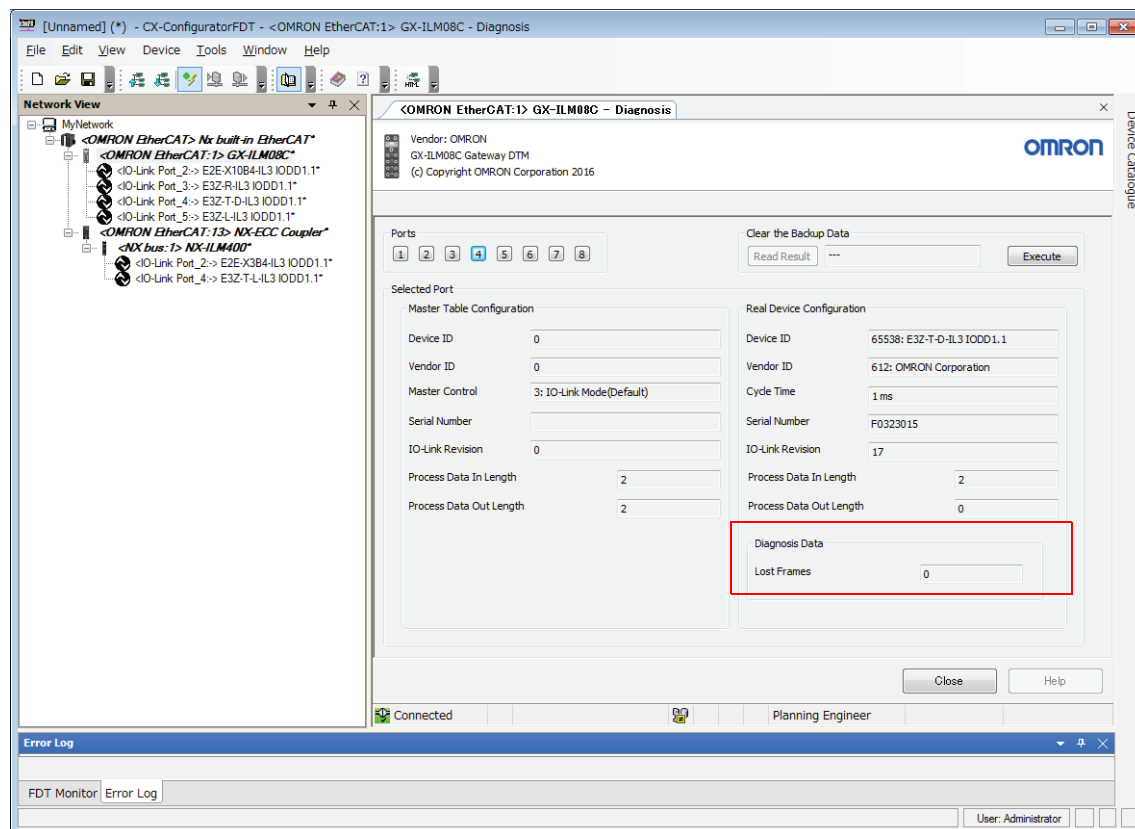

● Target Object Data

The target objects that can be accessed with communications instructions are given below.

Setting (= object name)	Description	Default	Setting range	Unit	NX-type IO-Link Master Unit		GX-type IO-Link Master Unit	
					Index	Subindex	Index	Subindex
Lost Frames	This setting stores the total number of lost frames of IO-Link cyclic communications. When writing, the totaling of the number of retries starts from the written data. Write 00 hex to reset the total.	00 hex	00 to FF hex When the maximum value of FF hex is reached, totaling stops at FF hex, and no further retries are counted.	Number of retries	500E hex	01 to 04 hex	A0*0 hex*1	02 hex

*1. Replace * with a number between 0 and 7.



Precautions for Correct Use

When you use the EtherNet/IP Coupler Unit with unit version 1.1 or earlier, you cannot use communications instructions for the IO-Link Master Unit. Connect the CX-ConfiguratorFDT to the peripheral USB port on the EtherNet/IP Coupler Unit and read the above object with the tool. Use the EtherNet/IP Coupler Unit with unit version 1.2 or later to use a communications instruction.

7-5 Digital Input Filter

This section describes filtering of digital inputs and digital inputs for pin 2.

7-5-1 Introduction

You can remove the chattering and noise of the input signal for digital inputs in SIO (DI) Mode or for digital inputs for pin 2 in IO-Link Mode.

When the input data changes without stabilization of the state of the contact point due to chattering and noise, this function prevents changes in data and stabilizes it.

7-5-2 Setting Method

Use the IO-Link Master Unit Configuration Tool or communications instructions addressed to the IO-Link Master Unit to set the Input Filter Setting for each port.

By default, the Input Filter Setting for each port is set to 1 ms.

● Applicable Communications Modes

- SIO (DI) Mode
- IO-Link Mode (digital inputs for pin 2)

● Related Parameters

Set the parameters to the following values from the IO-Link Master Unit Configuration Tool.

Setting (= object name)	Description	Default	Setting range
Input Filter Setting	Filters digital input values.	03 hex	0: No filter, 1: 0.25 ms, 2: 0.5 ms, 3: 1 ms, 4: 2 ms, 5: 4 ms, 6: 8 ms, 7: 16 ms, 8: 32 ms, 9: 64 ms, 10: 128 ms, or 11: 256 ms



Precautions for Correct Use

When you use the EtherNet/IP Coupler Unit with unit version 1.1 or earlier, you cannot use communications instructions for the IO-Link Master Unit. Connect the IO-Link Master Unit Configuration Tool to the peripheral USB port on the EtherNet/IP Coupler Unit and set the above parameter with the tool. Use the EtherNet/IP Coupler Unit with unit version 1.2 or later to use a communications instruction.

7-6 Backup and Restoration of Parameter Settings in IO-Link Devices

This section describes the backup and restoration of parameter settings in IO-Link devices.

7-6-1 Overview of Backup and Restore Operations

This function is used to back up the parameter settings from the IO-Link devices in the IO-Link Master Unit and restore them from the IO-Link Master Unit to the IO-Link devices.

This eliminates the need to set parameters again in an IO-Link device after replacing an IO-Link device with the same model of IO-Link device.

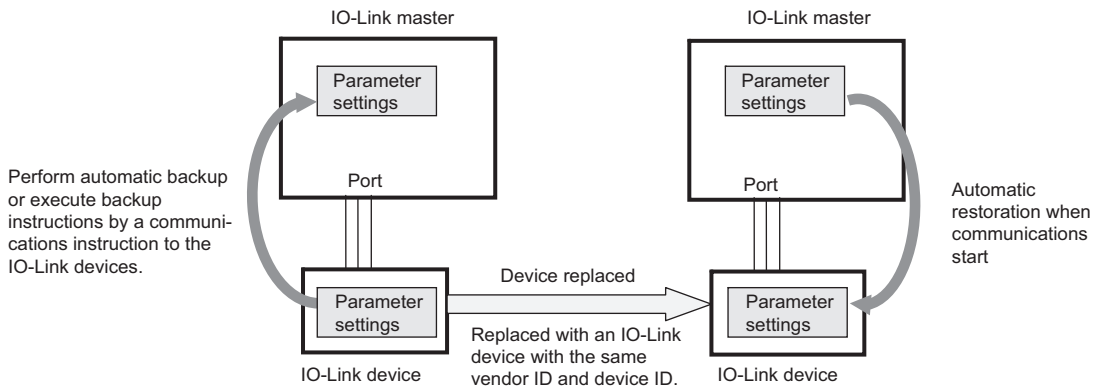

Precautions for Correct Use

If you use the IO-Link backup and restoration functions, enable connected device verification.

7-6-2 Backing Up Settings

You can back up the parameter settings of the IO-Link devices to the connected IO-Link Master Unit. The parameter settings that are backed up in the IO-Link Master Unit are called backup data.

Backup is performed according to the methods described below.

- Automatic Backup when IO-Link communications start
- Backing up data with a communications instruction start command
- Automatic Backup after Clearing Backup Data from the IO-Link Master Unit

However, to use any of these methods, the communications mode setting must be set to IO-Link Mode, device verification must be enabled for the port, and the device must match.

If backup fails, a warning-level device event is generated.

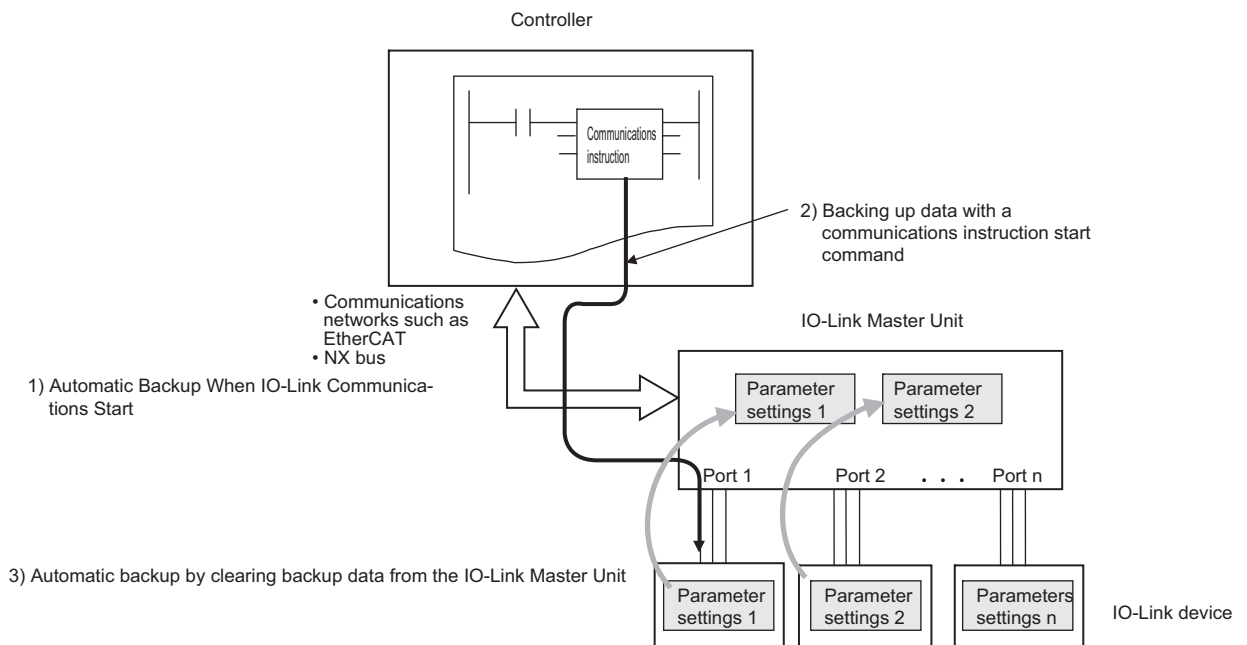

Precautions for Correct Use

- If you change any settings in an IO-Link device after backing up the parameter settings in the IO-Link devices to the IO-Link Master Unit, back up the parameter settings again.
- When you use the EtherNet/IP Coupler Unit with unit version 1.1 or earlier, you cannot use communications instructions for the IO-Link Master Unit. Use the EtherNet/IP Coupler Unit with unit version 1.2 or later to use a communications instruction.

Automatic Backup when IO-Link communications start

● When an IO-Link device is first connected

Backup is executed automatically when IO-Link communications start if the following three conditions are met.

- Device verification is enabled for the port and the parameter settings match.
- There is no backup data in the IO-Link Master Unit.
- Either backup, restoration, or both are enabled for the port.

● When replacing with an IO-Link device with different settings

This method is used if an IO-Link device is replaced with an IO-Link device with different settings.

Backup is executed automatically when IO-Link communications start if the following three conditions are met.

- Device verification is enabled for the port and the parameter settings match.
- Backup data already exists in the IO-Link Master Unit and the existing data is different from the parameter settings in the IO-Link device.
- Backup is enabled in the Backup Setting and restoration is disabled in the Restoration Setting for the port.

Backing up data with a communications instruction start command

This method is used to change the settings of an IO-Link device with communications instructions and back up the settings of only the individual IO-Link device, e.g., when changing over a production line.

Backup is executed during IO-Link communications if the following three conditions are met.

- Backup is enabled in the Backup Setting for the port.
- Device verification is enabled for the port and the parameter settings match.
- A start command is written to the Parameter Upload Start^{*1} IO-Link device object with a communications instruction for the IO-Link device.

*1. The index of the IO-Link device object is 0002 hex, and the write data is 05 hex (Start Command).

Automatic backup by clearing backup data from the IO-Link Master Unit

By clearing the backup data, the settings of the IO-Link device after change are backed up.

This method is used in the following cases.

- When the settings of IO-Link devices are changed by the CX-ConfiguratorFDT or a communications instruction.
- When the settings of the IO-Link devices are to be changed by a communications instruction and a backup is to be performed in the individual IO-Link Master Unit, e.g., when changing over a production line.

Backup is executed automatically when the following two conditions are met.

- Either backup, restoration, or both are enabled for the port.
- The clear operation for backup data in the IO-Link Master Unit was just executed with a) CX-ConfiguratorFDT or b) a communications instruction for the IO-Link Master Unit.*¹

*1. Refer to *Clearing Backup Data* on page 7-21 later in this manual for the procedures to clear backup data.



Precautions for Correct Use

You can also perform automatic backup by clearing backup data from the IO-Link Master Unit for IO-Link devices for which discrepancies were detected during device verification.

Clear backup data when all IO-Link devices verify or when any IO-Link devices for which discrepancies were found during verification are disconnected.

**Additional Information**

To initialize the backup data, use the CX-ConfiguratorFDT or execute a communications instruction for the IO-Link Master Unit to send a clear backup data command.

- **Applicable Communications Modes**

- IO-Link Mode

- **Connected Devices**

IO-Link devices^{*1}

*1. Specify IO-Link devices that have a Parameter Upload Start object.

**Additional Information**

Backup will fail if you attempt it for an IO-Link device that does not support the backup functions. If this occurs, a warning-level device event is generated.

- **Communications Instructions Used**

- a) Communications instructions to write data

Communications between the controller and IO-Link Master Unit	Type of controllers	Communications instruction
EtherCAT communications or NX bus communications	NJ/NX-series CPU Unit or NY-series Industrial PC	IOL_WriteObj (Write IO-Link Device Object) instruction
EtherNet/IP communications	NJ/NX-series CPU Unit or NY-series Industrial PC	<ul style="list-style-type: none"> • CIPSend (Send Explicit Message) instruction • CIPUCMMSend (Send Explicit Message) instruction
	CJ/CP/CS-series PLC	_IOL004_WriteObjEip (Write IO-Link Device Object)

For details on communications instructions, refer to 6-3-3 *Message Communications with IO-Link Devices* on page 6-12.

- b) Object data to write

Parameter Upload Start: The index of the IO-Link device object is 0002 hex and the write data is 05 hex (Start Command).

● Related Parameters

Set the parameters to the following values from the IO-Link Master Unit Configuration Tool.

Setting (= object name)	Description	Default	Setting range
Backup Setting	<p>Make this setting to back up the parameter settings of the IO-Link devices in the IO-Link Master Unit.</p> <p>Specify whether to enable or disable backup for each port.</p>	00 hex	<p>00 to 01 hex</p> <p>00 hex: Disables backup</p> <p>01 hex: Enables backup*¹</p>

*1. If the Restoration Setting is enabled, restoration will be executed rather than a backup when the parameter settings data for the IO-Link devices is different from the backup data. In this case, disable the Restoration Setting to execute a backup.

Refer to 7-2 *Connected Device Verification* on page 7-6 for information on the IO-Link Device Verification Setting.

7-6-3 Restoring Settings

After you replace an IO-Link device with the same model of IO-Link device, you can transfer (i.e., restore) the parameter settings (called backup data) that are backed up in the IO-Link Master Unit to the replacement IO-Link device from the IO-Link Master Unit.

Restoration is executed automatically when IO-Link communications start if the following two conditions are met. However, the communications mode setting must be set to IO-Link Mode, device verification must be enabled for the port, and the device must match.

- Restoring settings is enabled in the Restoration Setting for the port.
- Backup data already exists in the IO-Link Master Unit and the existing backup data is different from the parameter settings in the connected IO-Link device.

If backup fails, a warning-level device event is generated.

● Applicable Communications Modes

- IO-Link Mode

● Connected Devices

IO-Link devices ^{*1}

*1. Specify IO-Link devices that have a Parameter Upload Start object.

● Related Parameters

Set the parameters to the following values from the IO-Link Master Unit Configuration Tool.

Setting (= object name)	Description	Default	Setting range
Restoration Setting	Make this setting to automatically restore the parameter settings of the IO-Link devices from the IO-Link Master Unit. Specify whether to enable or disable restoration for each port.	00 hex	00 to 01 hex 00 hex: Disables restoration. 01 hex: Enables restoration. ^{*1}

*1. Even if restoring data is enabled, restoration will not be executed if there is no backup data in the IO-Link Master Unit.

Refer to *7-2 Connected Device Verification* on page 7-6 for information on the IO-Link Device Verification Setting.

7-6-4 Conditions for Backing Up and Restoring Parameter Settings When IO-Link Communications Start

The following conditions determine whether parameter settings are automatically backed up or restored when IO-Link communications start.

- Whether device verification is enabled and whether the device matches
- Whether there is backup data in the IO-Link Master Unit and whether the IO-Link devices match
- The combination of the backup and restoration settings

Parameter settings are backed up and restored when IO-Link communications start only when device verification is enabled and all devices verify.

The following tables show the backup and restoration conditions when IO-Link communications start assuming that device verification is enabled and all IO-Link devices verify.

● No Backup Data in the IO-Link Master Unit

Conditions		Operation when IO-Link communications start
Backup Setting	Restoration Setting	
Backup enabled.	Restoration enabled.	Parameter settings are backed up.
	Backup disabled.	
Backup disabled.	Restoration enabled.	Parameter settings are backed up.
	Backup disabled.	Nothing is done.

● Backup Data in the IO-Link Master Unit and IO-Link Devices Do Not Match

Conditions		Operation when IO-Link communications start
Backup Setting	Restoration Setting	
Backup enabled.	Backup enabled.	Parameter settings are restored.
	Restoration disabled.	Parameter settings are backed up.
Restoration disabled.	Backup enabled.	Parameter settings are restored.
	Restoration disabled.	Nothing is done.

● Backup Data in the IO-Link Master Unit and IO-Link Devices Match

Conditions		Operation when IO-Link communications start
Backup Setting	Restoration Setting	
Backup enabled.	Backup enabled.	Nothing is done.
	Restoration disabled.	Parameter settings are backed up.
Restoration disabled.	Backup enabled.	Nothing is done.
	Restoration disabled.	

7-6-5 Clearing Backup Data

You can clear the backup data from IO-Link devices that is stored in the IO-Link Master Unit. The backup data can be cleared when the IO-Link Master Unit is replaced with an IO-Link Master Unit to which IO-Link device backup data was previously written or when you are not sure what connection configuration the backup data is for.

If device verification is enabled, the parameter settings are backed up immediately after the backup data is cleared regardless of whether or not there is a verification mismatch.

To clear the backup data, you can use either the CX-ConfiguratorFDT or a communications instruction for the IO-Link Master Unit.

When the backup data is cleared, the backup data of all ports will be cleared.

● Applicable Communications Modes

- IO-Link Mode, SIO (DI) Mode, SIO (DO) Mode, or Disable Port

● Clearing Methods

Use one of the following two methods, a or b.

(a) Clearing Backup Data with the CX-ConfiguratorFDT

You can click the **Execute** button on the following Diagnosis Tab Page for the IO-Link Master Unit to clear the backup data from the IO-Link Master Unit. Click the **Read Result** button to display the results of the clearing operation. If the clearing operation is executed normally, *0x0000: Success* will be displayed.

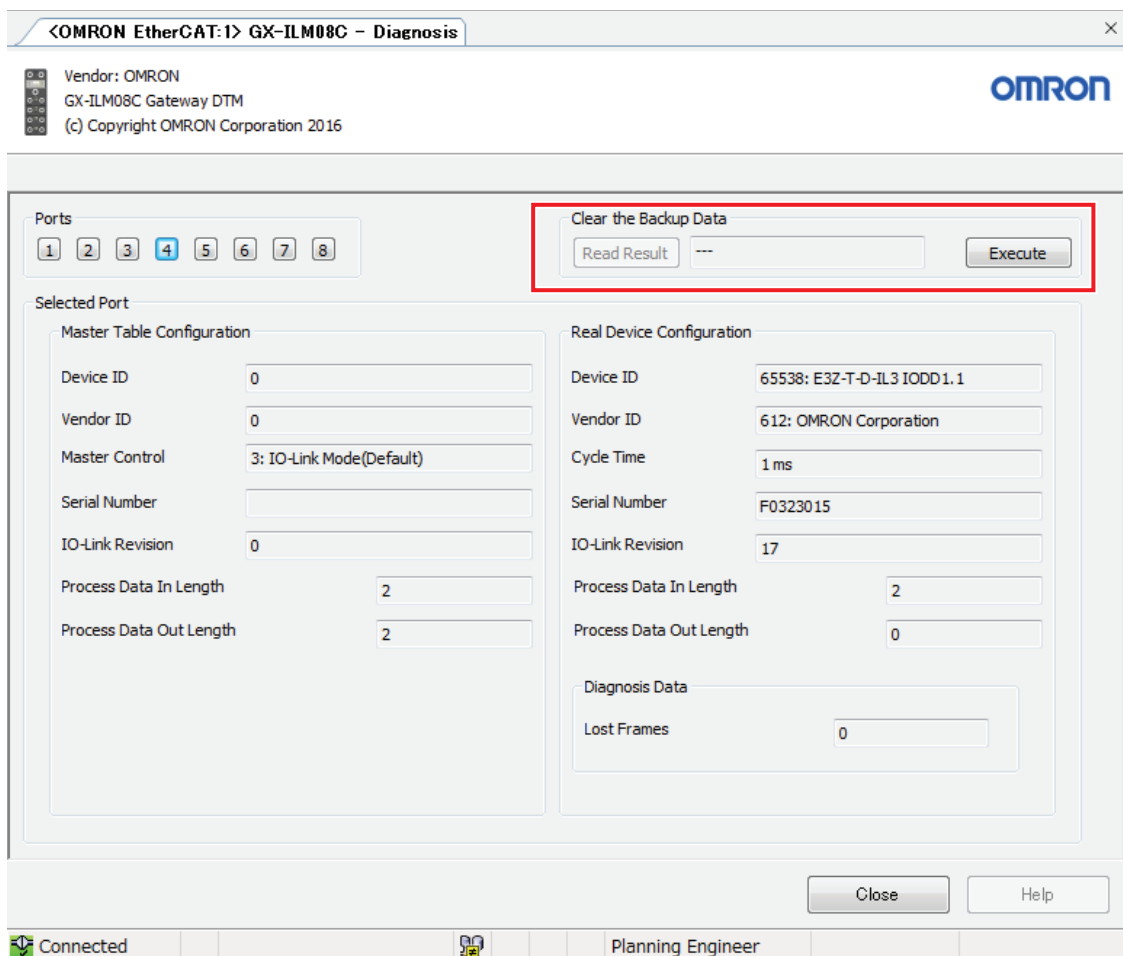

(b) Clearing Data with Communications Instructions

You can use the following communications instructions to clear the backup data from the IO-Link Master Unit.

Communications between the controller and IO-Link Master Unit	Type of controllers	Communications instruction
EtherCAT communications or NX bus communications	NJ/NX-series CPU Unit or NY-series Industrial PC	<ul style="list-style-type: none"> NX-type NX_WriteObj (Write NX Unit Object) instruction GX-type EC_CoESDOWrite (Write EtherCAT CoE SDO) instruction
EtherNet/IP communications	NJ/NX-series CPU Unit or NY-series Industrial PC	<ul style="list-style-type: none"> CIPSend (Send Explicit Message) instruction CIPUCMMSend (Send Explicit Message) instruction
	CJ/CP/CS-series PLC	CMND instruction (FINS 2810)

You can use the following communications instructions to read the clear status of the backup data in the IO-Link Master Unit.

Communications between the controller and IO-Link Master Unit	Type of controllers	Communications instruction or function block
EtherCAT communications or NX bus communications	NJ/NX-series CPU Unit or NY-series Industrial PC	<ul style="list-style-type: none"> NX-type NX_WriteObj (Write NX Unit Object) instruction GX-type EC_CoESDOWrite (Write EtherCAT CoE SDO) instruction
EtherNet/IP communications	NJ/NX-series CPU Unit or NY-series Industrial PC	<ul style="list-style-type: none"> CIPSend (Send Explicit Message) instruction CIPUCMMSend (Send Explicit Message) instruction
	CJ/CP/CS-series PLC	CMND instruction (FINS 2810)

For details on communications instructions, refer to 6-3-2 *Message Communications with the IO-Link Master* on page 6-9.

Use a communications instruction to write 01 hex to the following Command object of the IO-Link Master Unit.

You can use a communications instruction to read the backup data clear status from the following Result object.

Setting (= object name)		Description	Default	Setting range	NX-type IO-Link Master Unit		GX-type IO-Link Master Unit	
					Index	Sub-index	Index	Sub-index
Clear Backup Data Command	Command	This command clears the backup data in the IO-Link Master Unit.	00 hex	00 to 01 hex The backup data is cleared when the command changes from 00 hex to 01 hex.	5018 hex	01 hex	3209 hex	01 hex
	Result	This is the result of clearing the backup data.	0000 hex	0000 to FFFF hex 0000 hex: Normal end 0001 hex: Error end FFFF hex: Backup in progress.		02 hex		02 hex

The relation between the Command and Result objects is given below.

The backup data is cleared when the value of the Command object in the IO-Link Master Unit changes from 00 hex to 01 hex.

The value of the Result object is FFFF hex while clearing the data is in progress.

After the data is cleared, the value of the Result object changes to 0000 hex for a normal end and to 0001 hex for an error end.

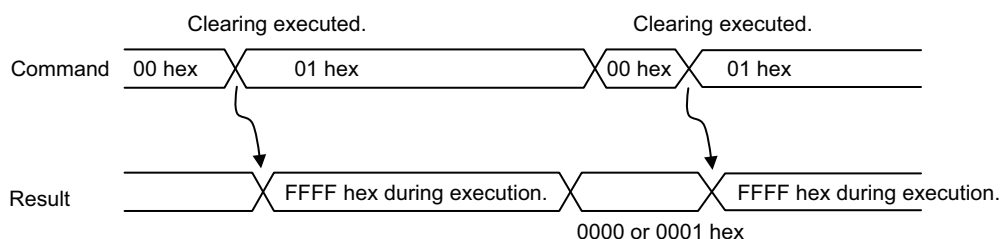

Precautions for Correct Use

- When you use the EtherNet/IP Coupler Unit with unit version 1.1 or earlier, you cannot use communications instructions for the IO-Link Master Unit. Use the CX-ConfiguratorFDT to clear the backup data. Use the EtherNet/IP Coupler Unit with unit version 1.2 or later to use a communications instruction.
- The backup data in the IO-Link Master Unit is not cleared by the clear all memory function for NX Units.

7-6-6 Application Procedure

For information on how to back up and restore parameter settings in IO-Link devices, refer to 10-3-2 *Replacing the IO-Link Master Unit or IO-Link Devices* on page 10-51.

7-7 Digital Input Collection

This section describes the digital input collection.

Version Information

The IO-Link Master Unit with unit version 1.1 or later is required to use the digital input collection.

7-7-1 Overview

In IO-Link Mode, this function reflects the specified bit data in the input data from the IO-Link device on the digital input data of the IO-Link Master Unit.

As a result, the bit data in the input data from the IO-Link device can be aggregated into the digital input data of the IO-Link Master Unit.

For example, you can use this function to input control bits in an IO-Link device that does not support digital inputs for pin 2 to the digital input data.

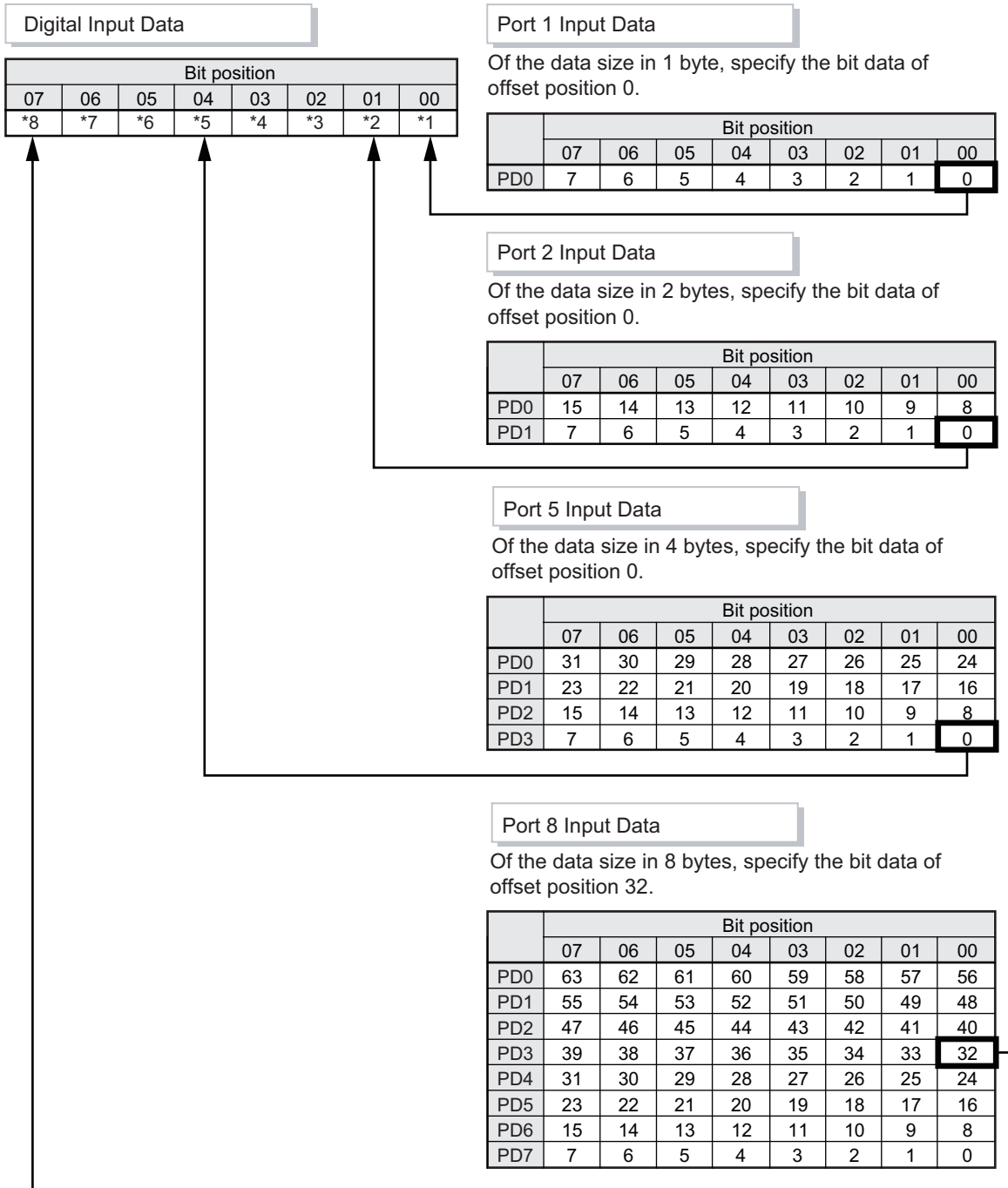

- *1. Specified bit data in Port 1 Input Data
- *2. Specified bit data in Port 2 Input Data
- *3. Specified bit data in Port 3 Input Data
- *4. Specified bit data in Port 4 Input Data
- *5. Specified bit data in Port 5 Input Data
- *6. Specified bit data in Port 6 Input Data
- *7. Specified bit data in Port 7 Input Data
- *8. Specified bit data in Port 8 Input Data

7-7-2 Setting Method

Set the Digital Input Collection Setting and Offset Setting of Digital Input Collection for each port with Sysmac Studio or a communications instruction for the IO-Link Master Unit.



Precautions for Correct Use

- For an offset setting value of the Offset Setting of Digital Input Collection, the bit position 00 of the last data in the input data serves as the offset position 0.

An example when the input data size is 4 bytes is shown below.

	Bit positions							
	07	06	05	04	03	02	01	00
PD0	31	30	29	28	27	26	25	24
PD1	23	22	21	20	19	18	17	16
PD2	15	14	13	12	11	10	9	8
PD3	7	6	5	4	3	2	1	0

Offset position 0

- If the offset value that exceeds the input data size is set, the bit data collected in the digital input data is always 0.

Example 1: If the input data size is 2 bytes, the set range is enabled from 00 to 0F hex.

If the set range is 10 to FF hex, the bit data collected in the digital input data is always 0.

Example 2: If the input data size is 16 bytes, the set range is enabled from 00 to 7F hex.

If the set range is 80 to FF hex, the bit data collected in the digital input data is always 0.

● Applicable Communications Modes

IO-Link Mode

● Related Parameters

Set the parameters to the following values from the Sysmac Studio.

Setting	Meaning	Default	Setting range
Digital Input Collection Setting	Enables or disables digital input data collection for each port in IO-Link Mode. Digital input collection cannot be used in SIO (DI) Mode or SIO (DO) Mode and this setting is ignored.	Disabled	<ul style="list-style-type: none"> Disabled Enabled
Offset Setting of Digital Input Collection	Specifies the offset of the bit data to be collected in the input data from the IO-Link device, when the digital input collection is enabled for each port in IO-Link Mode. When the digital input collection is disabled in IO-Link Mode, this setting is ignored. This setting is also ignored in SIO (DI) Mode or SIO (DO) Mode.	00 hex	00 to FF hex*1

*1. For example, if you want to specify the bit data of offset position 32 with the port data size in 8 bytes, set the value to 20 hex.

The target objects that can be accessed with communications instructions addressed to the IO-Link Master Unit are given below.

Setting	Meaning	Default	Setting range	NX-type IO-Link Master Unit		GX-type IO-Link Master Unit	
				Index	Subindex	Index	Subindex
Digital Input Collection Setting	<ul style="list-style-type: none"> Enables or disables digital input data collection for each port in IO-Link Mode. Digital input collection cannot be used in SIO (DI) Mode or SIO (DO) Mode and this setting is ignored. 	00 hex	00 to 01 hex 00 hex: Digital Input Collection Disable 01 hex: Digital Input Collection Enable	501A hex	01 hex to 04 hex	320B hex	01 hex to 08 hex
Offset Setting of Digital Input Collection	<ul style="list-style-type: none"> Specifies the offset of the bit data to be collected in the input data from the IO-Link device, when the digital input collection is enabled for each port in IO-Link Mode. When the digital input collection is disabled in IO-Link Mode, this setting is ignored. This setting is also ignored in SIO (DI) Mode or SIO (DO) Mode. 	00 hex	00 to FF hex ^{*1}	501B hex	01 hex to 04 hex	320C hex	01 hex to 08 hex

*1. For example, if you want to specify the bit data of offset position 32 with the port data size in 8 bytes, set the value to 20 hex.

8

Applicable Support Software for IO-Link Systems

This section describes the applicable Support Software and their procedures for IO-Link Systems.

8-1 Applications and Types of the Support Software	8-2
8-2 Sysmac Studio Procedures	8-4
8-2-1 Flow of Operations on the Sysmac Studio	8-4
8-2-2 Setting Parameters in the IO-Link Master Unit	8-7
8-2-3 Changing I/O Data Sizes in the IO-Link Master Unit	8-8
8-3 NX-IO Configurator Procedures	8-13
8-3-1 Setting Parameters in the IO-Link Master Unit	8-13
8-3-2 Changing I/O Data Sizes in the IO-Link Master Unit	8-13
8-4 CX-ConfiguratorFDT Procedures	8-14
8-4-1 Overview of CX-ConfiguratorFDT	8-14
8-4-2 Flow of Operations for CX-ConfiguratorFDT	8-15
8-4-3 Installing CX-ConfiguratorFDT in Your Computer	8-16
8-4-4 Installing IODD Files for IO-Link Devices from Other Companies in CX-ConfiguratorFDT	8-16
8-4-5 Starting CX-ConfiguratorFDT	8-17
8-4-6 Creating the Network Configuration	8-18
8-4-7 Going Online	8-24
8-4-8 Transferring the IO-Link Device Parameters	8-36

8-1 Applications and Types of the Support Software

Use the following Support Software for IO-Link Systems.

Detailed information is given in the following tables for the NX-type IO-Link Master Units and GX-type IO-Link Master Units.

Refer to the following sections for each Support Software procedures.

- Refer to 8-2 *Sysmac Studio Procedures* on page 8-4 when you use the Sysmac Studio.
- Refer to 8-3 *NX-IO Configurator Procedures* on page 8-13 when you use the NX-IO Configurator.
- Refer to 8-4 *CX-ConfiguratorFDT Procedures* on page 8-14 when you use the CX-ConfiguratorFDT.

● NX-type IO-Link Master Units

Communications with the controller	Controller	Applications			
		I/O data allocation settings for controller	I/O allocation settings	IO-Link Master Unit settings* ¹	Setting and monitoring the IO-Link devices
EtherCAT	NJ/NX-series CPU Unit	Sysmac Studio	Sysmac Studio	Sysmac Studio	CX-ConfiguratorFDT* ²
	NY-series Industrial PC				
	Host controller from another company	EtherCAT software application from another company			
Ether-Net/IP	NJ/NX-series CPU Unit	Sysmac Studio or Network Configurator			
	NY-series Industrial PC				
	CJ/CP/CS-series PLC or controller from another company	Network Configurator	NX-IO Configurator* ³ or Sysmac Studio	NX-IO Configurator* ³ or Sysmac Studio	
NX bus	NX-series CPU Unit	Sysmac Studio	Sysmac Studio	Sysmac Studio	

*1. The IO-Link device connection configuration information settings are included in the IO-Link Master Unit settings.

*2. In terms of specifications, an FDT tool (FDT1.2.1) from another company can be used. OMRON takes no responsibility for the operation of software from other companies.

*3. The connectable paths differ depending on the unit version of the EtherNet/IP Coupler Unit. For details on the connection paths, refer to the *NX-IO Configurator Operation Manual* (Cat. No. W585).

● **GX-type IO-Link Master Units**

Communi- cations with the controller	Controller	Applications			
		I/O data alloca- tion settings for controller	PDO allocation settings	IO-Link Master Unit settings ^{*1}	Setting and mon- itoring the IO-Link devices
EtherCAT	NJ/NX-series CPU Unit	Sysmac Studio	Sysmac Studio	Sysmac Studio	CX-Configura- torFDT ^{*2}
	NY-series Indus- trial PC				
	Host controller from another company	EtherCAT soft- ware applica- tion from another company	EtherCAT soft- ware applica- tion from another company	EtherCAT soft- ware applica- tion from another company	^{*3}

- *1. The IO-Link device connection configuration information settings are included in the IO-Link Master Unit settings.
- *2. In terms of specifications, an FDT tool (FDT1.2.1) from another company can be used. OMRON takes no responsibility for the operation of software from other companies.
- *3. Make the settings with message communications from the controller from another company.

8-2 Sysmac Studio Procedures

The Sysmac Studio is used to assign I/O data and set parameters in the IO-Link Master Unit. This section describes the flow of operations when you use the Sysmac Studio. Refer to *1-6 Startup Procedures* on page 1-24 for the basic procedure for the entire IO-Link System.

8-2-1 Flow of Operations on the Sysmac Studio

The following gives the operation flow on the Sysmac Studio for each type of communications with the controller.

Controller Communications with EtherCAT

The following describes the procedure to use an NJ/NX-series CPU Unit, an NY-series Industrial PC, or a controller from another company as the controller.

● Using an NJ/NX-series CPU Unit or NY-series Industrial PC as the Controller

Use the Sysmac Studio to set EtherCAT PDO allocations, make NX/GX-type IO-Link Master Unit settings, enter the programs, and make adjustments.

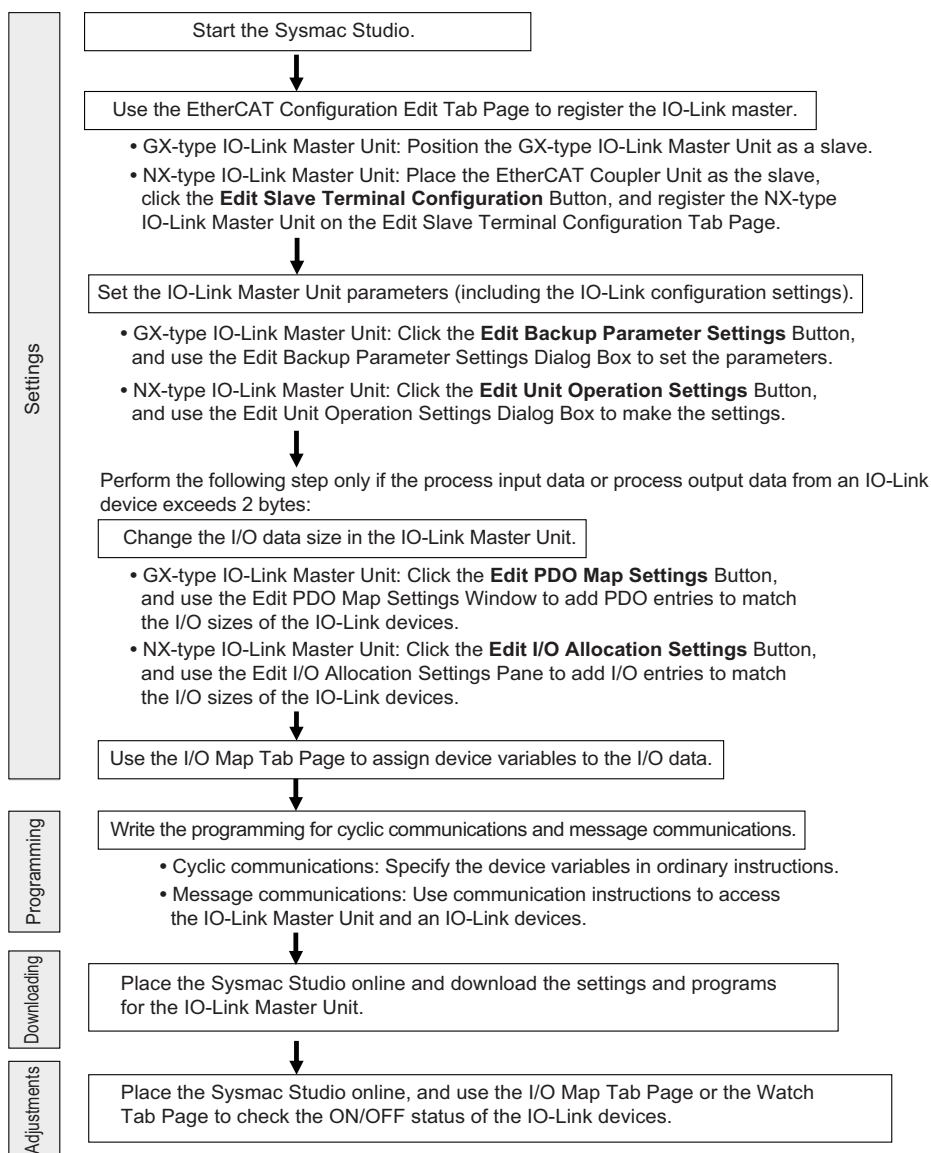

- **Using a Controller from Another Company**

For information on NX-type IO-Link Master Unit settings from the Sysmac Studio for EtherCAT controller communications with a controller from another company, refer to *A-1-1 Using a Controller from Another Company with EtherCAT Communications* on page A-2.

Controller Communications with EtherNet/IP

The following describes the procedure to use an NJ/NX-series CPU Unit, NY-series Industrial PC, CJ/CP/CS-series PLC, or controller from another company as the controller.

- **Using an NJ/NX-series CPU Unit or NY-series Industrial PC as the Controller**

For information on making settings for an NX-type IO-Link Master Unit from Sysmac Studio when using an NJ/NX-series CPU Unit or NY-series Industrial PC as the controller with EtherNet/IP communications, refer to *A-1-2 Using an NJ/NX-series CPU Unit or NY-series Industrial PC with EtherNet/IP Communications* on page A-10.

Use the Sysmac Studio to set EtherNet/IP tag data links, make NX-type IO-Link Master Unit settings, enter the programs, and make adjustments.

- **Using a CJ/CP/CS-series PLC or a Controller from Another Company**

For information on making settings for an NX-type IO-Link Master Unit from Sysmac Studio when using a CJ/CP/CS-series PLC or a controller from another company with EtherNet/IP communications, refer to *A-1-3 Using a CJ/CP/CS-series PLC or a Controller from Another Company with EtherNet/IP Communications* on page A-16.

Controller Communications with NX Bus

This description assumes that the controller is an NX-series CPU Unit.

Use the Sysmac Studio to set CPU Unit I/O allocations, make NX-type IO-Link Master Unit settings, enter the programs, and make adjustments.

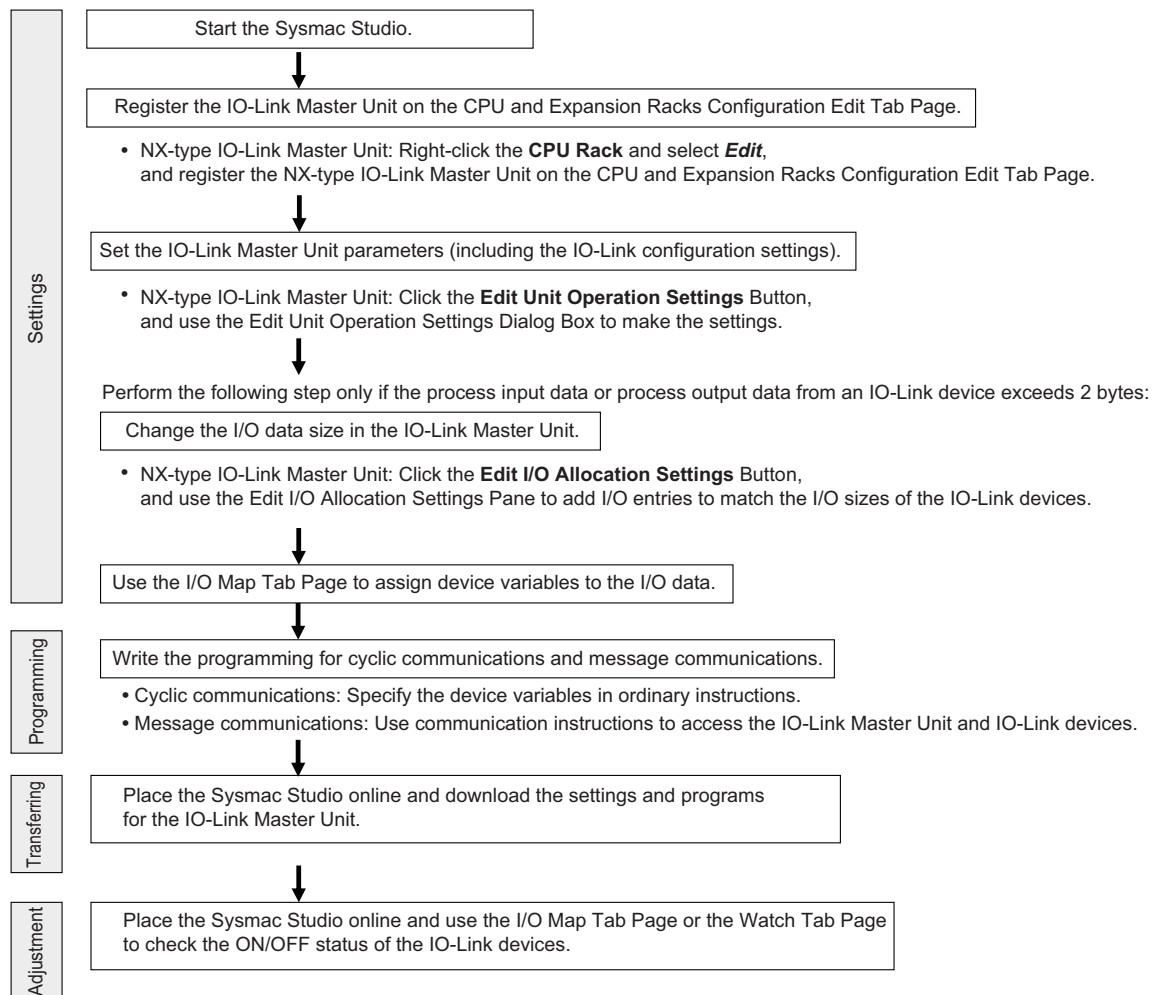

8-2-2 Setting Parameters in the IO-Link Master Unit

This section describes the parameter setting procedure for IO-Link Master Units, including the IO-Link device configuration settings.

For an NX-type IO-Link Master Unit, the settings are made in the Edit Slave Terminal Configuration Tab Page. For a GX-type IO-Link Master Unit, the settings are made on the Edit Backup Parameter Settings Tab Page.

NX-type IO-Link Master Units

● Connected to an EtherCAT Coupler Unit

- 1 Open the project for the controller.
- 2 On the EtherCAT Edit Tab Page, select the Coupler Unit and click the **Edit Slave Terminal Configuration** Button.
- 3 On the Edit Slave Terminal Configuration Tab Page, select the NX-type IO-Link Master Unit and click the **Edit Unit Operation Settings** Button.
- 4 The Edit Unit Operation Settings Tab Page is displayed. Set the parameters.

● Connected to an EtherNet/IP Coupler Unit

- 1 Open the project for the Slave Terminal (EtherNet/IP device).
- 2 Right-click the **EtherNet/IP Coupler Unit** and select **Edit** from the menu.
- 3 On the Edit Slave Terminal Configuration Tab Page, select the NX-type IO-Link Master Unit and click the **Edit Unit Operation Settings** Button.
- 4 The Edit Unit Operation Settings Tab Page is displayed. Set the parameters.

● Connected to a CPU Unit

- 1 Open the project for the connected CPU Unit.
- 2 Right-click **CPU Racks** under **CPU and Expansion Racks** and select **Edit**.
- 3 On the CPU and Expansion Racks Configuration Tab Page, select the NX-type IO-Link Master Unit and click the **Edit Unit Operation Settings** Button.
- 4 The Edit Unit Operation Settings Tab Page is displayed. Set the parameters.

GX-type IO-Link Master Units

- 1 On the EtherCAT Edit Tab Page, select the GX-type IO-Link Master Unit and click the **Edit Backup Parameter Settings** Button.
- 2 The Edit Backup Parameter Settings Window is displayed. Set the parameters.

8-2-3 Changing I/O Data Sizes in the IO-Link Master Unit

For an NX-type IO-Link Master Unit, the settings are made in the Edit I/O Allocation Settings Pane. For a GX-type IO-Link Master Unit, the settings are made in the Edit PDO Map Settings Window.

NX-type IO-Link Master Units

● Connected to an EtherCAT Coupler Unit

- 1 On the EtherCAT Configuration Edit Tab Page, select the Coupler Unit and click the **Edit Slave Terminal Configuration** Button.
- 2 On the Edit Slave Terminal Configuration Tab Page, select **NX-type IO-Link Master Unit** and click the **Edit I/O Allocation Settings** Button.

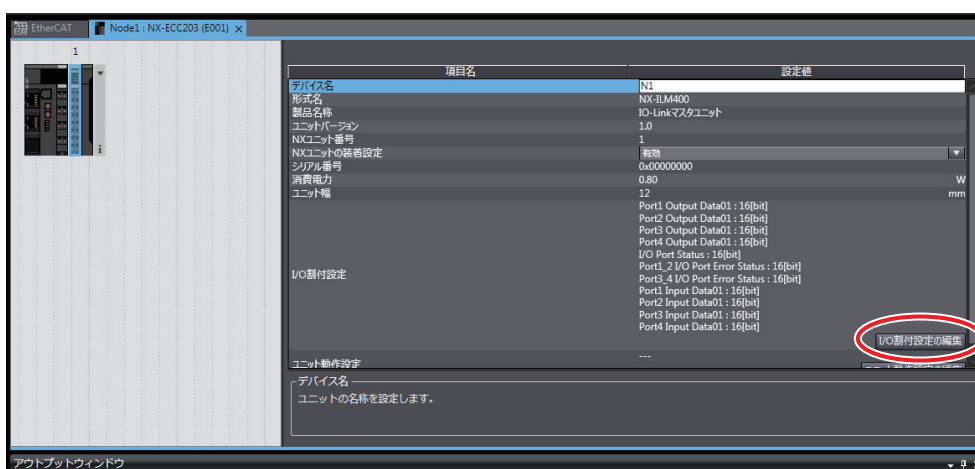

- 3 The Edit I/O Allocation Settings Pane is displayed.
 - If the IO-Link process input data or the IO-Link process output data from a connected IO-Link device exceeds 2 bytes, use the Edit I/O Allocation Settings Pane to add an I/O entry to match the size of the IO-Link process input data or the IO-Link process output data of the IO-Link device.
 - 1) Select an option button in the *Selection* Column of the I/O entry mappings for which *Editable* is displayed in the *Flag* Column.
 - 2) Click the **Add I/O Entry** Button.

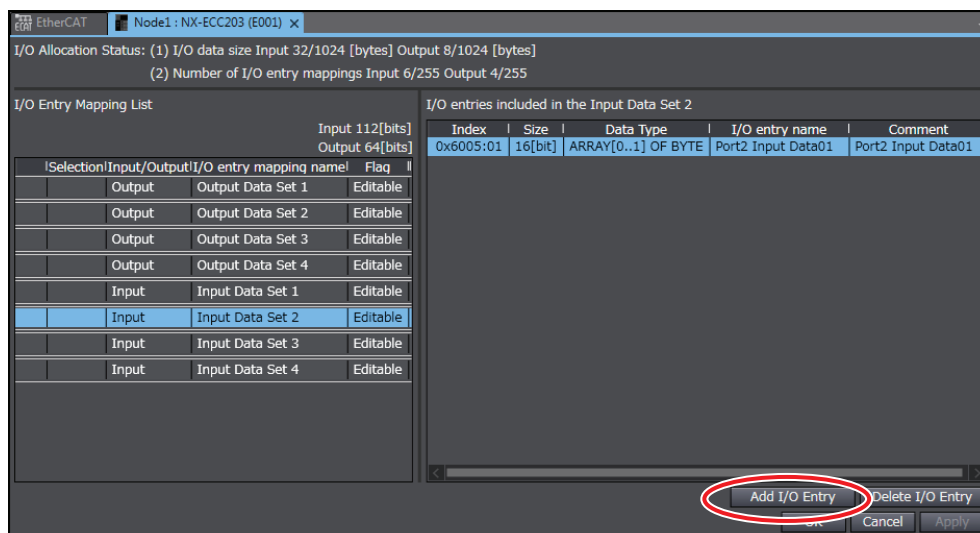

3) Select the I/O data to add.

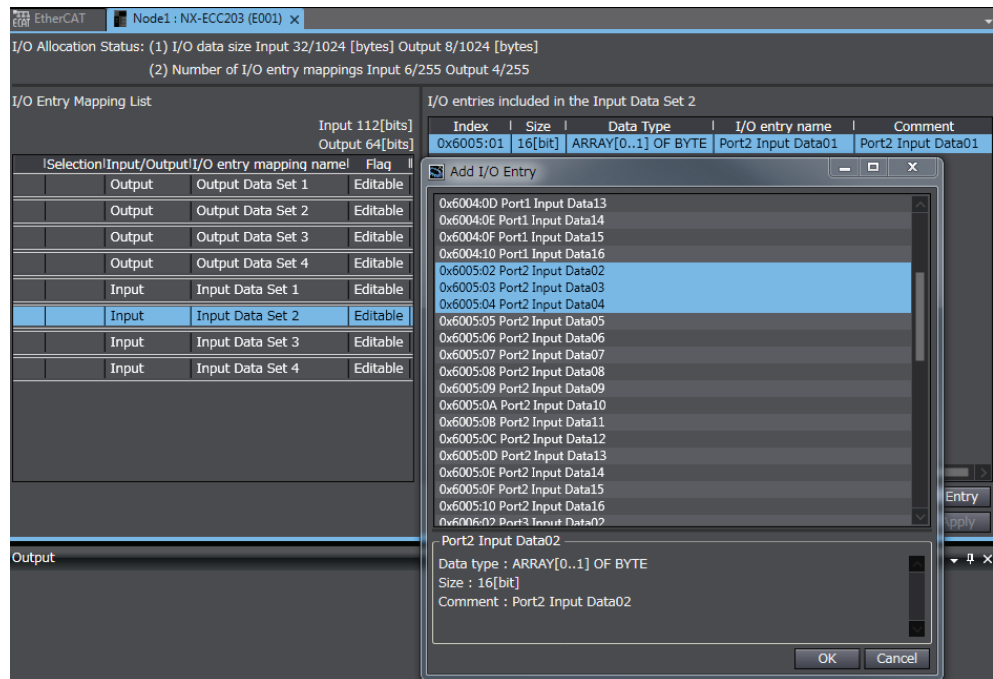

Precautions for Correct Use

Allocate the process input data from and process output data to IO-Link devices consecutively starting from data 01. A setting error will occur if the data allocations are not consecutive or are in reverse order.

A Slave Initialization Error occurs in the Communications Coupler Unit.

Examples: When the sequence is reversed, when allocations are not consecutive, and when there is port 1 data for port 2.

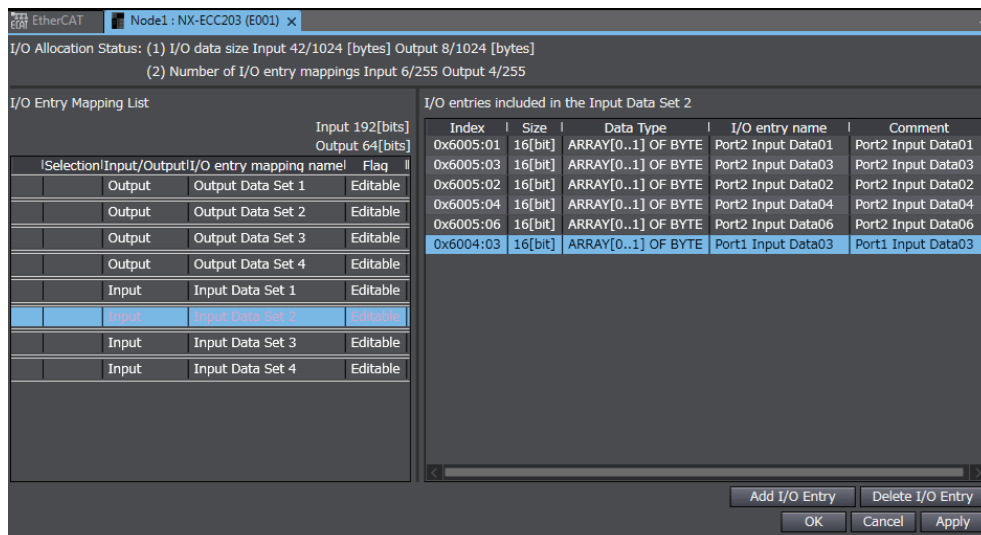

- To save the I/O data size for unused ports, delete the I/O entries for the unused ports from the I/O entry mapping list.

● Connected to an EtherNet/IP Coupler Unit

- 1 Open the project for the Slave Terminal (EtherNet/IP device).
- 2 Right-click the **EtherNet/IP Coupler Unit** and select **Edit**.
- 3 On the Edit Slave Terminal Configuration Tab Page, select **NX-type IO-Link Master Unit** and click the **Edit I/O Allocation Settings** Button.

For the subsequent procedure, refer to step 3 when connected to an EtherNet/IP Coupler Unit.

● Connected to a CPU Unit

- 1 Open the project for the connected CPU Unit.
- 2 Right-click **CPU Racks** under **CPU and Expansion Racks** and select **Edit**.
- 3 On the CPU and Expansion Racks Configuration Tab Page, select the **NX-type IO-Link Master Unit** and click the **Edit I/O Allocation Settings** Button.

For the subsequent procedure, refer to step 3 when connected to an EtherNet/IP Coupler Unit.

GX-type IO-Link Master Units

- 1 On the EtherCAT Edit Tab Page, select the GX-type IO-Link Master Unit and click the **Edit PDO Mapping Settings** Button.

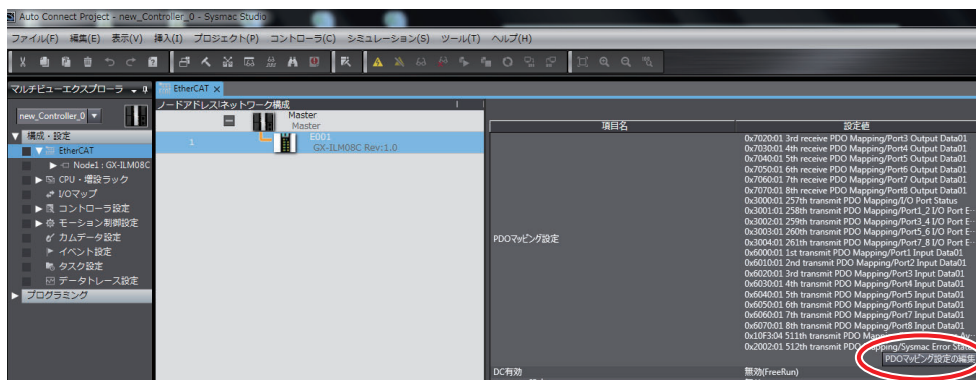

- 2 The Edit PDO Map Settings Window is displayed.
 - If the IO-Link process input data or the IO-Link process output data from a connected IO-Link device exceeds 2 bytes, use the Edit PDO Mapping Settings Window to add an I/O entry to match the size of the IO-Link process input data or the IO-Link process output data of the IO-Link device.
 - 1) Select an option button in the *Selection* Column of the PDO mappings for which *Editable* is displayed in the *Flag* Column.

2) Click the **Add PDO Entry** Button.

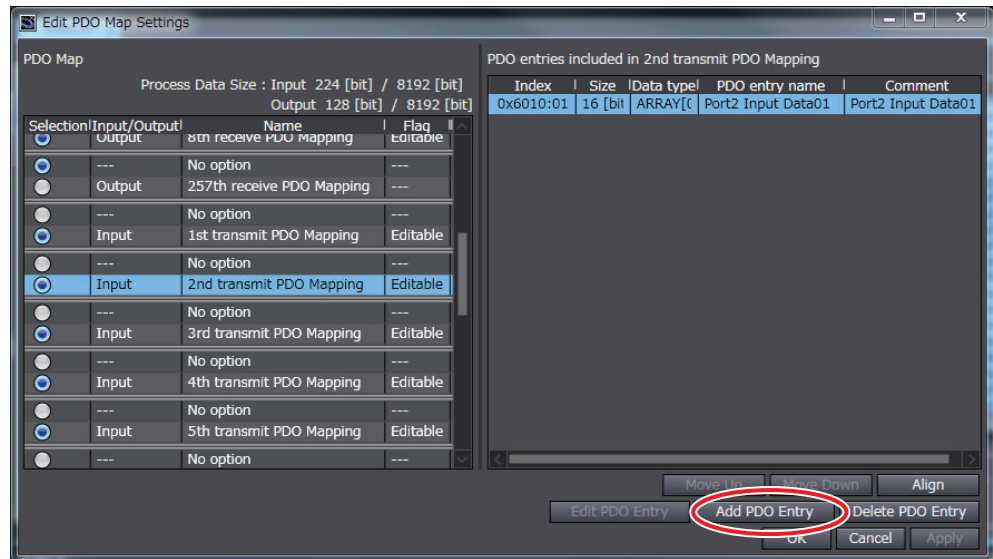

3) Select the I/O data to add.

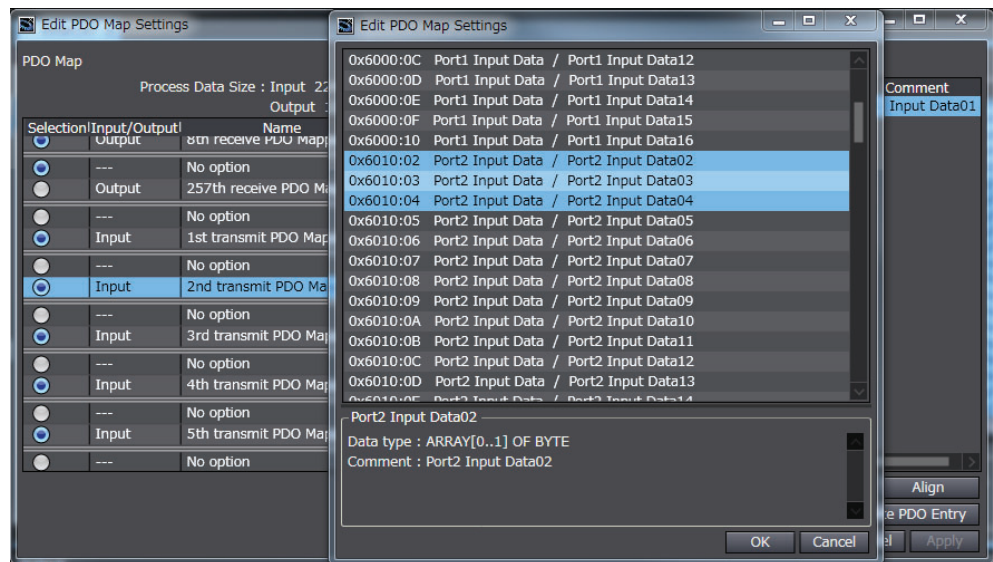



Precautions for Correct Use

Allocate the process input data from and process output data to IO-Link devices consecutively starting from data 01. A setting error will occur if the data allocations are not consecutive or are in reverse order.

A Slave Initialization Error occurs in the IO-Link Master Unit.

Examples: When the sequence is reversed, when allocations are not consecutive, and when there is port 1 data for port 2.

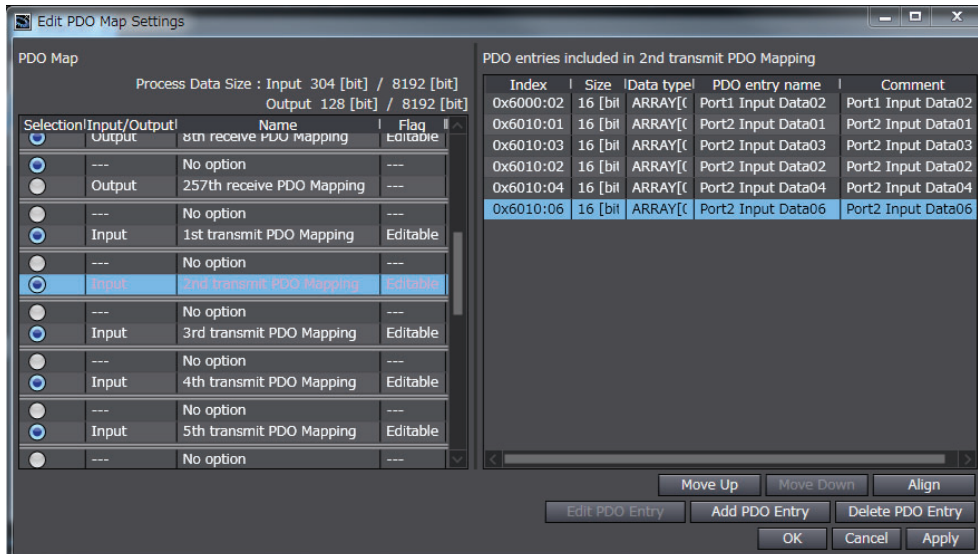

- To save the I/O data size for unused ports, clear the selections of the PDO mappings for the unused ports in the PDO mapping list.

8-3 NX-IO Configurator Procedures

The NX-IO Configurator is used to set the EtherNet/IP Slave Terminal.

It allows you to make the settings of an NX-type IO-Link Master Unit connected to the EtherNet/IP Coupler Unit.

8-3-1 Setting Parameters in the IO-Link Master Unit

Create a project, display the Edit Unit Operation Settings Tab Page of the NX-type IO-Link Master Unit from the Edit Slave Terminal Configuration Tab Page, and set the parameters.

For details on how to create a project, display the Edit Slave Terminal Configuration Tab Page and Edit Unit Operation Settings Tab Page, refer to the *NX-IO Configurator Operation Manual* (Cat. No. W585).

8-3-2 Changing I/O Data Sizes in the IO-Link Master Unit

Create a project, display the Edit I/O Allocation Settings Pane of the NX-type IO-Link Master Unit from the Edit Slave Terminal Configuration Tab Page, and change the I/O data sizes. The procedure to change the I/O data sizes in the Edit I/O Allocation Settings Pane is the same as the procedure with Sysmac Studio.

For details on the procedure with Sysmac Studio, refer to *8-2-3 Changing I/O Data Sizes in the IO-Link Master Unit* on page 8-8.

For details on how to create a project, display the Edit Slave Terminal Configuration Tab Page and Edit I/O Allocation Settings Pane, refer to the *NX-IO Configurator Operation Manual* (Cat. No. W585).

8-4 CX-ConfiguratorFDT Procedures

This section gives an overview of CX-ConfiguratorFDT and its operation.

8-4-1 Overview of CX-ConfiguratorFDT

The CX-ConfiguratorFDT is an FDT frame application for setting, diagnosing, and maintaining field devices.

You can make parameter settings for the IO-Link devices by using the CX-ConfiguratorFDT.

Functions of CX-ConfiguratorFDT

- After you create a network configuration, you can set the IO-Link device parameters and then read or write (load or store) them with the actual IO-Link devices.
- You can save the network configuration and IO-Link device settings that you create in a project file.

Network Configuration

You create the network configuration by registering the path to the IO-Link Master Unit, the IO-Link Master Unit, and the IO-Link devices for ports of the IO-Link Master Unit from your computer (i.e., with CX-ConfiguratorFDT).

You create the network configuration by placing the following DTMs (device type managers) in the network configuration.

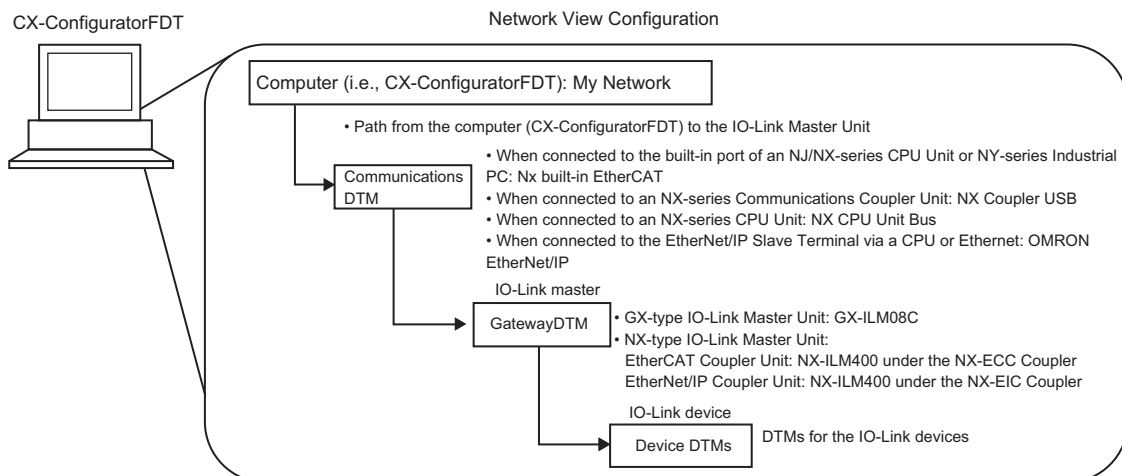

Version Information

You can use an OMRON EtherNet/IP of the communications DTMs with the CX-ConfiguratorFDT version 2.4 or higher.

8-4-2 Flow of Operations for CX-ConfiguratorFDT

For CX-ConfiguratorFDT, use the following flow of operations to set parameters for the IO-Link devices and check the I/O data (process data) of the IO-Link devices.

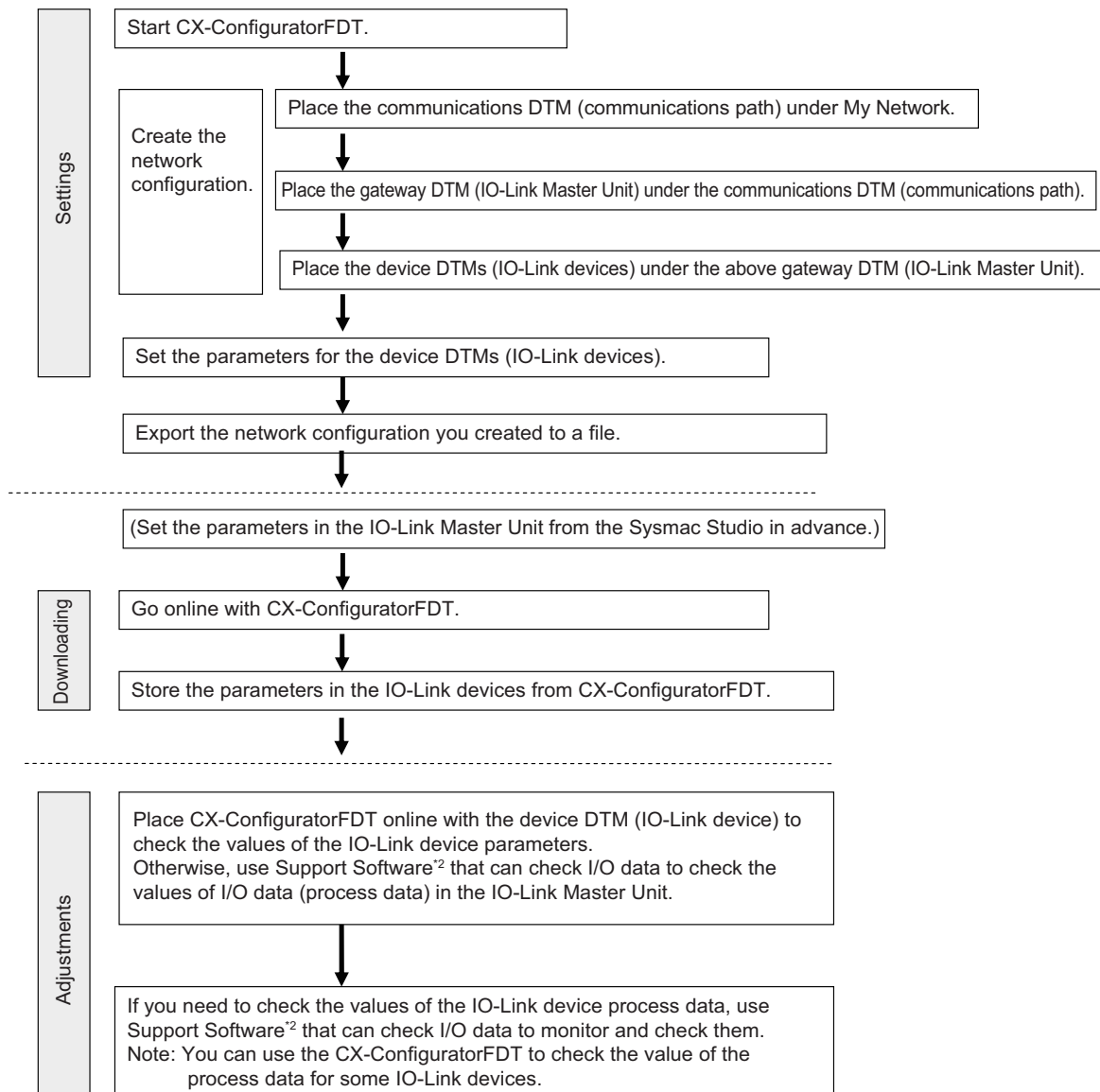

*1. The maximum number of devices DTMs for one communications DTM is 64. If there are more than 64 device DTMs, use more than one communications DTM.

*2. The Support Software that can check I/O data depends on the controller and communications network in the system configuration. Refer to the user's manual for the connected controller or Communications Coupler Unit for details.

8-4-3 Installing CX-ConfiguratorFDT in Your Computer

If you install the following Support Software, a version of CX-ConfiguratorFDT that supports IO-Link is installed automatically.

- When using an NJ/NX/NY-series Controller
Sysmac Studio version 1.16 or higher
- When using a CJ/CP/CS-series PLC
CX-One version 4.41 or higher

If you install the following Support Software, CX-ConfiguratorFDT version 2.4 or higher is installed automatically.

- When using an NJ/NX/NY-series Controller
Sysmac Studio version 1.19 or higher
- When using a CJ/CP/CS-series PLC
CX-One version 4.42 or higher

8-4-4 Installing IODD Files for IO-Link Devices from Other Companies in CX-ConfiguratorFDT

If you use IO-Link devices from another company, you must install the IODD files (i.e., XML files) for the IO-Link devices of that company in your computer.

Use the following method to install the files.

- 1** First, obtain the IODD files for the IO-Link devices from the device manufacturer.
- 2** Select **All Programs – IO-Link – IODD DTM Configurator** from the Windows Start Menu.
- 3** The IODDs that are currently installed in your computer are displayed on the Installed IODDs Tab Page.
- 4** Click the **Add IODD** Button, select the IODD files to add, and then click the **Open** Button.
The IODDs that you added are displayed on the Installed IODDs Tab Page.



Version Information

You cannot use the IODD DTM Configurator to add or delete individually the IODD files with the same vendor ID, device ID and IO-Link revision, but different file version.

Perform the following operations to delete the installed OMRON IODD files.

- To add IODD files
When you add the IODD files with the same vendor ID, device ID and IO-Link revision, but different file version, IODD files with the installed file version are overwritten.
- To delete IODD files
If several IODD files with the same vendor ID, device ID and IO-Link revision, but different file version are installed, when you delete individually the relevant IODD files, all of IODD files differ from IODD files with the installed file version are deleted.

When you made a mistake and deleted different files, select OMRON IOLink IOOD Files Setup from **Control Panel - Programs and Features**, right-click the OMRON IOLink IOOD Files Setup and execute *Repair*, the deleted files can be recovered.



Additional Information

- A set of OMRON IODD files is installed when you install the CX-ConfiguratorFDT.

8-4-5 Starting CX-ConfiguratorFDT

Use one of the following methods to start CX-ConfiguratorFDT.

- Click the **CX-ConfiguratorFDT** Shortcut Icon on your computer's desktop.
- When Sysmac Studio is installed, select **All Programs – OMRON – Sysmac Studio – CX-ConfiguratorFDT** from the Windows Start Menu.
- When CX-One is installed, select **All Programs – OMRON – CX-One – CX-ConfiguratorFDT** from the Windows Start Menu.

The first time you start CX-ConfiguratorFDT, a dialog box to update the catalog is displayed automatically.



Precautions for Correct Use

- Before you store (download) the settings to IO-Link devices, confirm that the controlled system will not be adversely affected.
- You must update the device catalog after you install CX-ConfiguratorFDT or after you install new DTMs.
- If DTM reading fails after you update the CX-One or restart the CX-ConfiguratorFDT application, update the device catalog.
- You cannot read and write the values displayed for the process data below the menus on the IO-Link Device Setting Tab Page.
An error is not displayed even if you perform one of the following operations for those values.
 - Loading from device or storing in device
 - Reading from device (Upload) or writing to device (Download)
 - Enabling cycle read from device from device for process data
 - Reading comparison values from device or writing different values to device



Additional Information

You can click the **Update** Button on the Device Catalog Tab Page to update the catalog.

8-4-6 Creating the Network Configuration

Register the path to the IO-Link Master Unit, the IO-Link Master Unit, and the IO-Link devices for ports of the IO-Link Master Unit from your computer (i.e., with CX-ConfiguratorFDT) to create the network configuration.

You can create the network configuration by selecting the configuration devices or you can automatically create it based on the devices that are actually connected.

● Creating the Network Configuration by Selecting the Configuration Devices

1 Start CX-ConfiguratorFDT.

2 Right-click **My Network** in the Network View and select **Add**.

In the Add Dialog Box, select one of the following communications DTMs (communications paths) for the path from your computer (i.e., CX-ConfiguratorFDT) to the IO-Link Master Unit, and click the **Yes** Button.

- If you connect your computer (i.e., CX-ConfiguratorFDT) to the IO-Link Master Unit through the built-in EtherCAT port on an NJ/NX-series CPU Unit or NY-series Industrial PC: NX built-in EtherCAT
- If you connect your computer (i.e., CX-ConfiguratorFDT) to the IO-Link Master Unit through the EtherCAT or the EtherNet/IP Coupler Unit USB port: NX Coupler USB*1
- *1. For an EtherCAT master from another company, you can use only this connection method.
- If you connect your computer (i.e., CX-ConfiguratorFDT) to the IO-Link Master Unit through the NX bus of an NX-series CPU Unit: NX CPU Unit Bus
- If you connect your computer (i.e., CX-ConfiguratorFDT) to the IO-Link Master Unit that is connected to an EtherNet/IP Coupler Unit through the controller or EtherNet/IP: OMRON EtherNet/IP

3 Right-click the above communications DTM (communications path), select **Add**, and then click the **Yes** Button.

In the Add Dialog Box, select one of the following gateway DTMs (IO-Link Master Units) and click the **Yes** Button

- GX-type IO-Link Master Unit: GX-ILM08C
- NX-type IO-Link Master Unit: NX-ECC Coupler and then NX-ILM400
When using EtherCAT communications, select NX-ECC Coupler and then NX-ILM400
When using EtherNet/IP communications, select NX-EIC Coupler and then NX-ILM400

4 Set the addresses for the gateway DTMs (IO-Link Master Units).

Double-click each gateway DTM (IO-Link Master Unit), and make the following setting, which is displayed on the right.

- GX-ILM08C and NX-ECC Coupler: Set the EtherCAT node (station) address.
- NX-ILM400: Set the NX Unit number (the sequence of connection to the Coupler from the left to the right, starting with 1 on the far left).
- NX-EIC Coupler: Set the IP address of the EtherNet/IP Coupler Unit of the connection destination.

- 5** Right-click the above gateway DTMs (IO-Link Master Unit), select **Add**, and then click the **Yes** Button.

In the Add Dialog Box, select one of the following device DTMs (IO-Link devices) for the each IO-Link device and click the **Yes** Button.

For example, set *E3Z-D-IL3 IODD1.1* for a E3Z Photoelectric Sensor and *E2E-X7B4-IL3 IODD1.1* for an E2E Proximity Sensor.

- 6** Select one of the following connection ports from the Select Channel Dialog Box.
- GX-ILM08C: IO-Link Port_1 to IO-LinkPort_8
 - NX-ILM400: IO-Link Port_1 to IO-Link Port_4

● Automatically Creating the Configuration from the Connected Devices

- 1** Select the DTMs to use and then select **Set** from the Device Menu to set the following values in advance.
- NX built-in EtherCAT: Connection method settings
 - OMRON EtherNet/IP: Connection method settings
 - GX-ILM08C: EtherCAT station address setting
 - NX-ECC Coupler: EtherCAT station address setting
 - NX-EIC Coupler: IP address setting
 - NX-ILM400: NX Unit unit number setting
 - NX Coupler USB: No setting
 - NX CPU Unit Bus: Connection method settings

Refer to *8-4-7 Going Online* on page 8-24 for the connection method settings.

- 2** Use one of the following operations to connect the CX-ConfiguratorFDT.
- Connecting the CX-ConfiguratorFDT to the Controller
 - (1) Right-click **NX built-in EtherCAT**, **OMRON EtherNet/IP**, or **NX CPU Unit Bus** and select **Scan – Create Network**. The downstream network configuration is created automatically.
 - (2) Follow the message displayed on the CX-ConfiguratorFDT.

Note 1. You can right-click **NX built-in EtherCAT** and select **Scan – Life List** to create the configuration of EtherCAT slaves (GX-ILM08C or NX-ECC Coupler) connected to the built-in EtherCAT port of the NJ/NX-series CPU Unit or NY-series Industrial PC.

2. You can right-click **OMRON EtherNet/IP** and select **Scan – Life List** to create the configuration of EtherNet/IP slaves (NX-EIC Coupler) connected to the built-in EtherNet/IP port of the NJ/NX-series CPU Unit, NY-series Industrial PC, or CJ-series PLC or to the EtherNet/IP Unit.

3. You can right-click **NX CPU Unit Bus** and select **Scan – Life List** to create the configuration of NX Units (NX-ILM400) connected to the NX bus of a CPU Unit.

- Connecting the CX-ConfiguratorFDT to the EtherNet/IP
 - (1) Right-click **OMRON EtherNet/IP** and select **Scan – Create Network**. The downstream network configuration is created automatically.
 - (2) Follow the message displayed on the CX-ConfiguratorFDT.

Note You can right-click **OMRON EtherNet/IP** and select **Scan - Life List** to create the configuration of EtherNet/IP slaves (NX-EIC Coupler) connected to EtherNet/IP.

- Connecting the CX-ConfiguratorFDT to the EtherCAT Coupler Unit or EtherNet/IP Coupler Unit
- (1) Right-click **NX Coupler USB** and select **Scan – Create Network**. The downstream network configuration is created automatically.
 - (2) Follow the message displayed on the CX-ConfiguratorFDT.

Note You can right-click **NX Coupler USB** and select **Scan - Life List** to create the configuration of NX Units (NX-ILM400) connected to the NX-series Communications Coupler Unit.



Additional Information

If the IO-Link device that is detected by an automatic network configuration creation has the IODD files with more than one version, you can click the **Change Device Type** Button in the Life List Window to change the version.

The following figure is an example that clicks the **Yes** Button to change the version of IODD files that is used in the detected IO-Link device from Ver.1.011 to Ver.1.10.

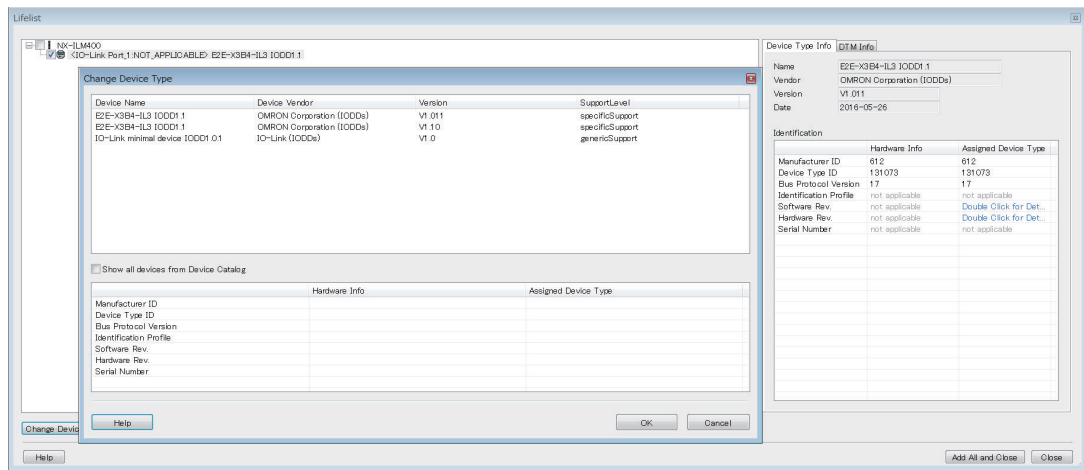

You can also select **NX-ECC Coupler**, **GX-ILM08C**, **NX-EIC Coupler**, or **NX-ILM400** to automatically create the downstream network configuration in the same way.

(The following is an example of the EtherCAT network configuration.)

Support Software:
CX-ConfiguratorFDT

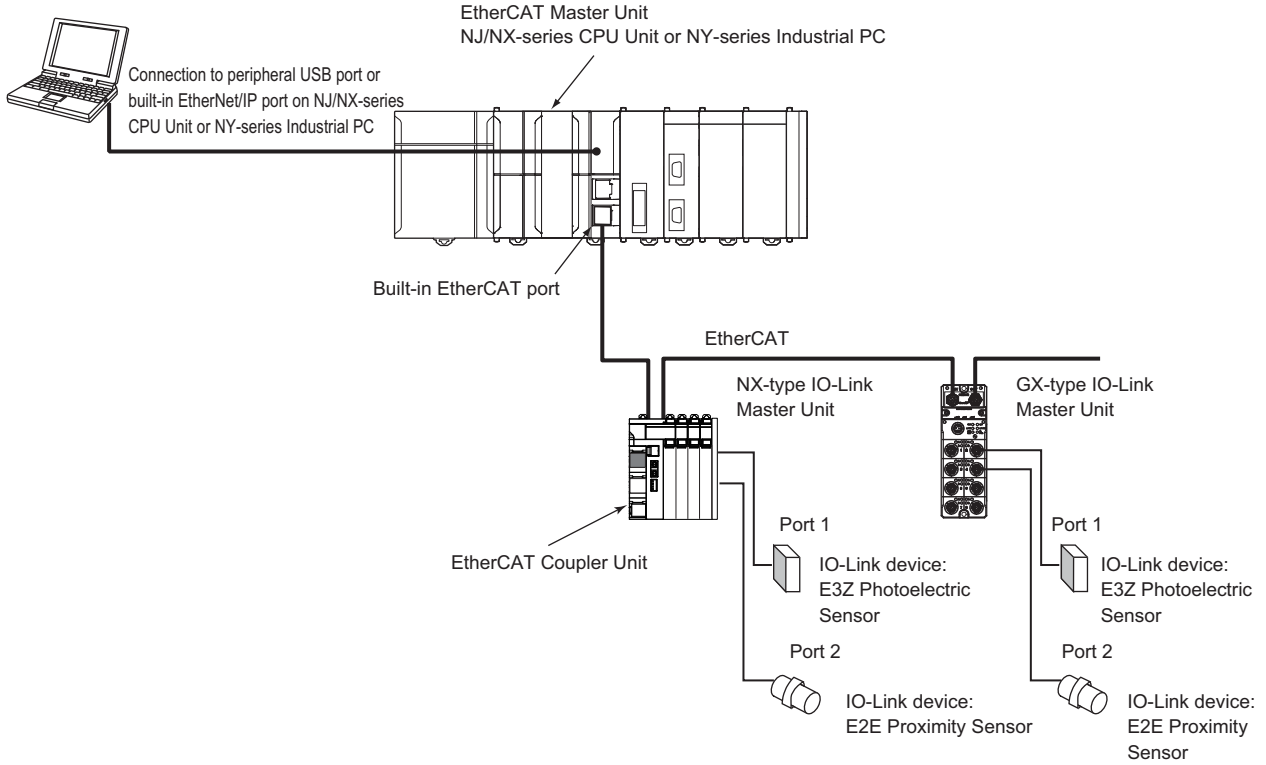

For the above system configuration, use CX-ConfiguratorFDT to create a network configuration as shown below.

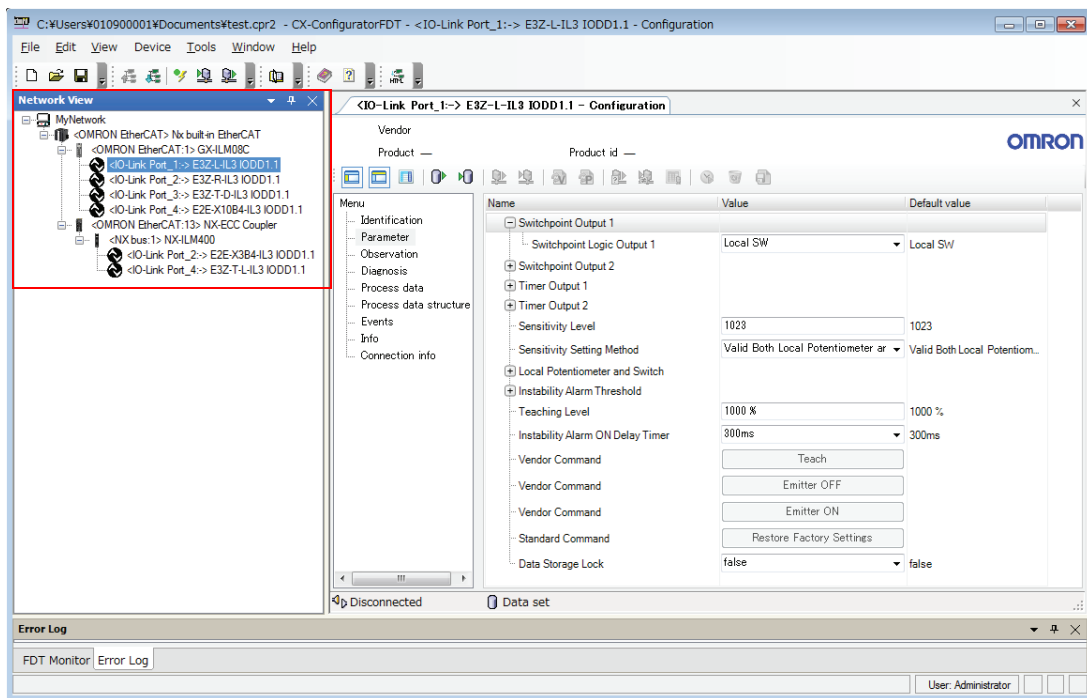

Exporting the Created Network Configuration to a File

You can save the network configuration that you created to an XML file.

- 1** Select **Import/Export – Export** from the File Menu.
- 2** Enter the file name and click the **Save** Button. The network configuration displayed in the current Network View is saved to an XML file.

Importing the Network Configuration from a File

An exported network configuration file (XML file) can be imported.

- 1** Select **Import/Export – Import** from the File Menu.
- 2** Select the file and click the **Open** Button. The network configuration is imported and displayed in the Network View.

Setting the IO-Link Device Parameters

- 1** Double-click the device DTM for the IO-Link device.
- 2** Double-click **Parameter** under **Menu** in the settings displayed on the right.
For the *Value* for each IO-Link device, select a candidate from the drop-down list or enter a value.

Storing the Parameters for an IO-Link Device



Precautions for Correct Use

You cannot store the parameters in the IO-Link device if *Cycle Read* is set to *Enable* for *Dynamic variables* or *Process data* in the settings for the IO-Link device.

Always set *Cycle Read* to *Disable* if you want to store the Observation/Parameter parameter in the IO-Link device.

- 1** Right-click the device DTM for the IO-Link device and select **Online Status**.
Devices in the Network View are displayed in bold while you are online.
- 2** Right-click the device DTM again and select **Save to Device**.
The parameter settings are stored in the IO-Link device.

Loading Parameter Settings from IO-Link Devices



Precautions for Correct Use

You cannot load the parameters from the IO-Link device if *Cycle Read* is set to *Enable* for *Dynamic variables* or *Process data* in the settings for the IO-Link device.

Always set *Cycle Read* to *Disable* if you want to load the Observation parameter from the IO-Link device.

- 1** Right-click the device DTM for the IO-Link device and select **Online Status**.
Devices in the Network View are displayed in bold while you are online.
- 2** Right-click the device DTM again and select **Load from Device**.
The parameter settings are uploaded from the IO-Link device.



Precautions for Correct Use

An IO-Link device configuration that is created with Network View in the CX-ConfiguratorFDT is not compatible with the IO-Link Master Unit Configuration Tool parameters or IO-Link Device configuration settings created with communications instructions sent to the IO-Link Master Unit.

Therefore, always make the configuration settings in the IO-Link Master Unit Configuration Tool.

8-4-7 Going Online

This section describes the settings or procedures for an online connection with each communication DTM.

When the Communication DTM Is an NX Coupler USB

Connection example

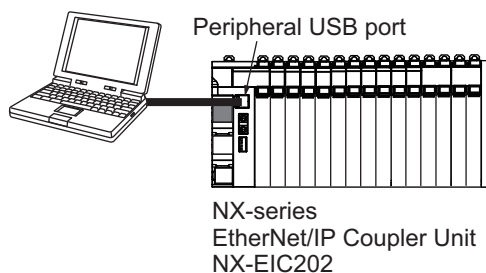

- 1 Right-click **Communication DTM** in the Network View and select **Go online**. Or, select the Communication DTM in the Network View, and then select **Go online** from the Device Menu.
If the connection is successful, the Support Software goes online.

When the Communication DTM Is an Nx built-in EtherCAT or NX CPU Unit Bus

- 1 Right-click **Communication DTM**, select **Configuration** or select **Configuration** from the Device Menu.
The Connection Type Dialog Box is displayed.

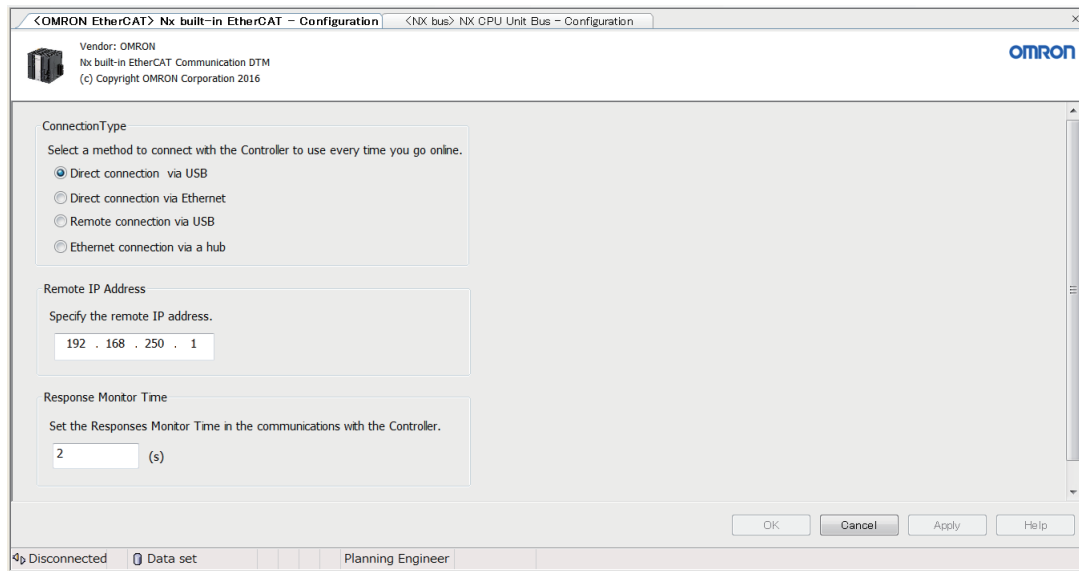

- 2 Select one of the following four connection methods.

Connection method	Description
Direct connection via USB	The USB port on the computer is connected directly to the peripheral USB port on the Controller.
Direct connection via Ethernet	The Ethernet port on the computer is connected directly to the built-in EtherNet/IP port on the Controller.
Remote connection via USB	The USB port on the computer is connected directly to the peripheral USB port on a Controller and then a connection is made through the Ethernet network to the built-in EtherNet/IP port on another Controller.
Ethernet connection via a hub	The Ethernet port on the computer is connected through the Ethernet network to the built-in EtherNet/IP port on a Controller.

- 3 Right-click **Communication DTM** in the Network View and select **Go online**. Or, select the Communication DTM in the Network View, and then select **Go online** from the Device Menu. If the connection is successful, the Support Software goes online.

When the Communication DTM Is an OMRON EtherNet/IP

● Select the Connection Method

- 1 Right-click **Communication DTM**, select **Configuration** or select **Configuration** from the Device Menu.

The **OMRON EtherNet/IP - Configuration** Tab Page is displayed.

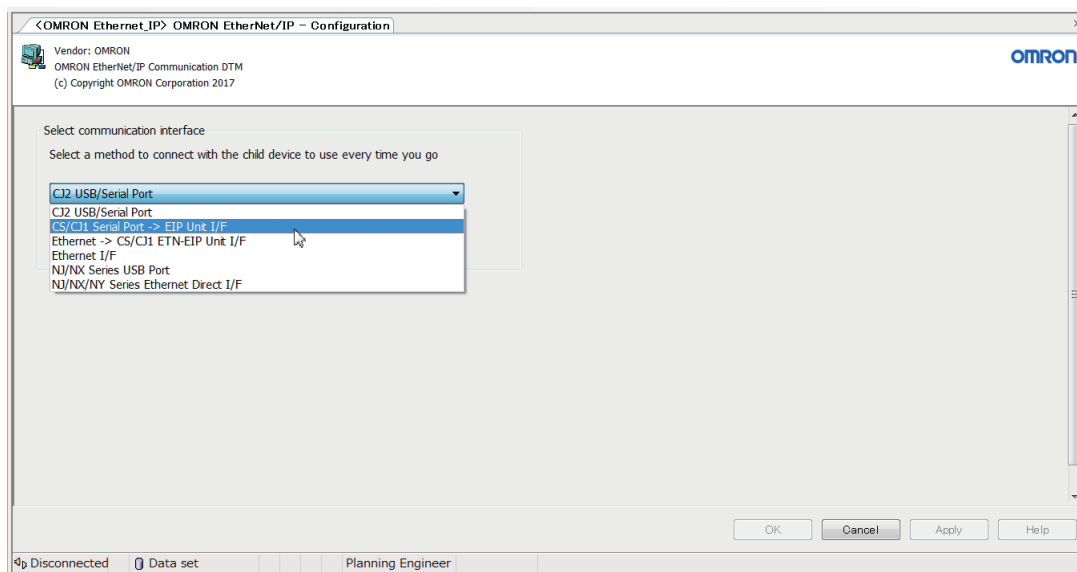

There are the following interface types according to the different connection path.

Interface	Description
CJ2 USB/Serial Port	Connect to the Ethernet port on an EtherNet/IP Unit via the USB port or serial port on a CJ2-series PLC.
CS/CJ1 Serial Port ->EIP Unit I/F	Connect to the Ethernet port on an EtherNet/IP Unit via the peripheral USB port or serial port on a CS/CJ-series PLC.
Ethernet I/F	Connect to the Ethernet port on an EtherNet/IP Unit or an EtherNet/IP Coupler Unit via an Ethernet.
Ethernet -> CS/CJ1 ETN-EIP Unit I/F	Connect to the Ethernet port on an EtherNet/IP Unit via the Ethernet Unit or EtherNet/IP Unit mounted on an CS/CJ1-series PLC using an Ethernet interface.
NJ/NX Series USB Port	Connect to the Ethernet port on an EtherNet/IP Unit via the USB port on an NJ/NX-series CPU Unit.
NJ/NX/NY Series Ethernet Direct I/F	Connect directly from the Ethernet to the built-in EtherNet/IP port. It is not necessary to set the IP address in the computer.

2 Select an interface.

The following gives the procedure to go online with each interface.

● **CJ2 USB/Serial Port**

Connection example

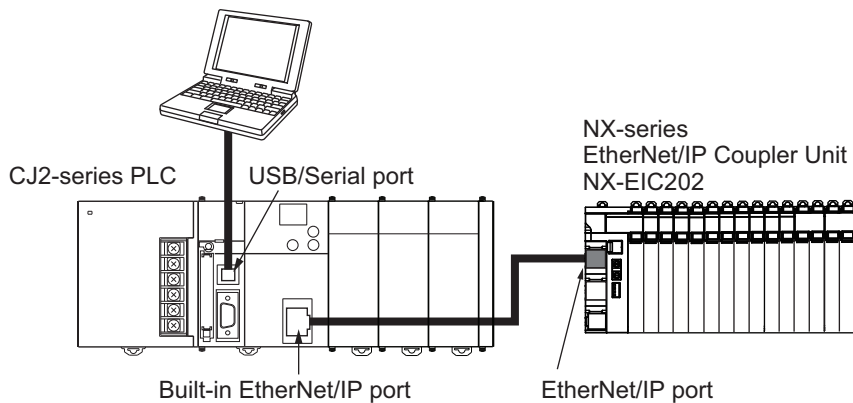

- 1** Right-click **Communication DTM** in the Network View and select **Go online**. Or, select the Communication DTM in the Network View, and then select **Go online** from the Device Menu. The **Setup Interface** Dialog Box is displayed.

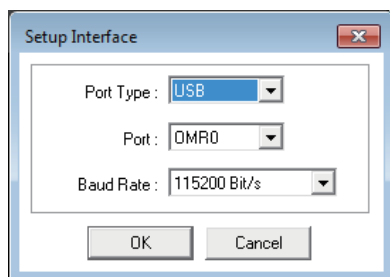

- 2 Set the **Port Type**, **Port**, and **Baud Rate** to suitable values and then click the **OK** Button to connect to the CJ2-series PLC.

If the connection is successful, the **Browse Network** Dialog Box is displayed.

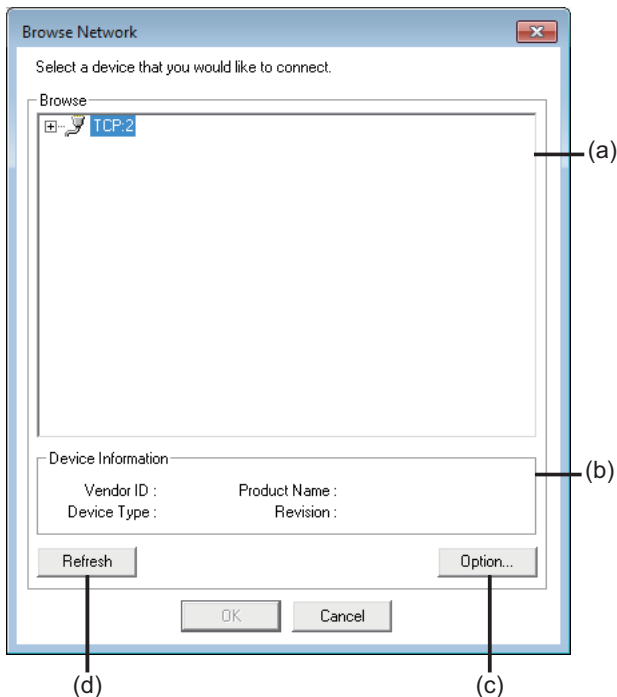

	Item	Description
(a)	Network list	Networks and devices that you can connect to are listed.
(b)	Device Information	Information on the selected device is displayed.
(c)	Option Button	Set the behavior of the network list display function.
(d)	Refresh Button	Click this to update the network list.

- 3 Click the **Option** Button.
The **Option** Dialog Box is displayed.

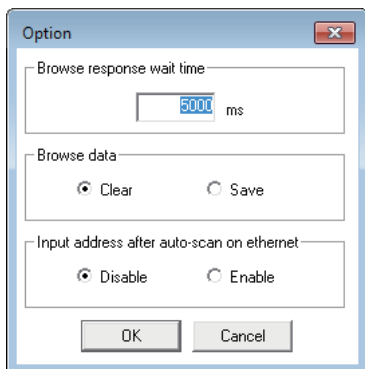

Item	Description
Browse response wait time	Sets the time (in 0.001 s) to monitor the connection timeout when you click the Refresh Button in the Browse Network Dialog Box.
Browse data	Specify whether to retain the network status data that you browse in the Browse Network Dialog Box for display in the next connection.
Input address after auto-scan on ethernet	Specify whether to enable IP address entry by the user after automatic network scanning.

- 4 Set the options as necessary and then click the **OK** Button.
You return to the **Browse Network** Dialog Box.

- 5 In the **Browse Network** Dialog Box, select **BackPlane** and click the **Refresh** Button.
The CJ2-series PLC and the Communication Units that are mounted on it are now listed.
- 6 Select **TCP:2** port on the CJ2-series PLC or **TCP:2** port on the Communication Unit and click the **OK** Button.
The Support Software goes online.



Precautions for Correct Use

When the computer and communication DTM are connected in the following connection configuration, you cannot select the same communications port in the **Setup Interface** Dialog Box to go online with more than one communication DTM at the same time. Doing so causes the later connection attempts to fail.

Connection configuration:

The computer is connected to the serial port on a CJ2-series PLC through a USB-Serial Conversion Cable (CS1W-CIF31) and an online connection is established via the tool bus protocol.

● **CS/CJ1 Serial Port ->EIP Unit I/F**

Connection example

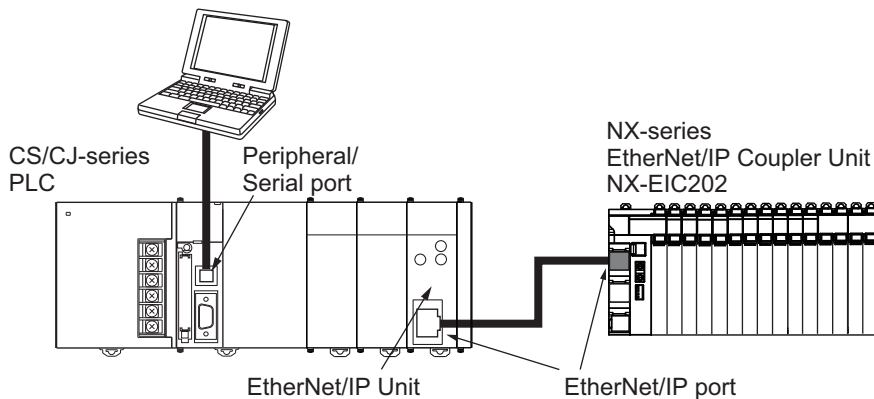

- 1 Right-click **Communication DTM** in the Network View and select **Go online**. Or, select the Communication DTM in the Network View, and then select **Go online** from the Device Menu.
The **Setup Interface** Dialog Box is displayed.

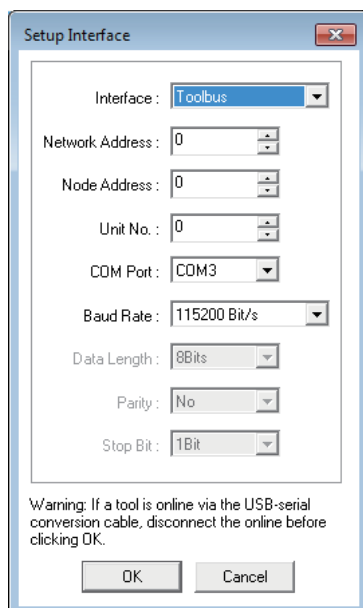

Item	Description
Interface	Select the serial communications mode for the serial communications port on the CS/CJ1-series PLC. You can select Toolbus or Host Link.
Network Address	Enter the network address of the connected EtherNet/IP Unit. Specify the network address if data passes over the network at a point beyond the serial communications port of the CS/CJ1-series PLC. Otherwise, enter 0.
Node Address	Enter the node address of the connected EtherNet/IP Unit. Specify the network address if data passes over the network at a point beyond the serial communications port of the CS/CJ1-series PLC. Otherwise, enter 0.
Unit No.	Enter the Unit number of the connected EtherNet/IP Unit as a CPU Bus Unit.
COM Port	Select the COM port of the computer that you use for communications.
Baud Rate	Set the baud rate of the serial communications port on the CS/CJ1-series PLC.
Data Length	Set the data length for the serial communications port on the CS/CJ1-series PLC. The data length setting is valid when the host link interface is selected.
Parity	Set the parity for the serial communications port on the CS/CJ1-series PLC. The parity setting is valid when the host link interface is selected.
Stop Bit	Set the stop bit for the serial communications port on the CS/CJ1-series PLC. The stop bit setting is valid when the host link interface is selected.

- 2** Make the settings that are required to connect to the CS/CJ1-series PLC and then click the **OK** Button.
If the connection is successful, the **Browse Network** Dialog Box is displayed.
- 3** Set the options as necessary and then click the **Refresh** Button.
The PLC and the Communication Units that are mounted on it are now listed.
- 4** Select **TCP:2** port on the PLC or **TCP:2** port on the Communication Unit and click the **OK** Button.
The Support Software goes online.



Precautions for Correct Use

When the computer and communication DTM are connected in the following connection configuration, do not select the same communications port in the **Setup Interface** Dialog Box to go online with more than one communication DTM at the same time. Doing so causes not only the later connection attempts, but also all online operations that you will attempt after that on the communication DTM that is already online to fail.

Also, when other Support Software such as the Network Configurator uses the same communications port to go online with the communication DTM, all online operations from the Support Software will fail. In such cases, once go offline and then go online with the communication DTM again.

Connection configuration:

The computer is connected to the serial port on a CS/CJ1-series PLC through a USB-Serial Conversion Cable (CS1W-CIF31) and an online connection is established via the tool bus protocol.

● Ethernet I/F

Connection example

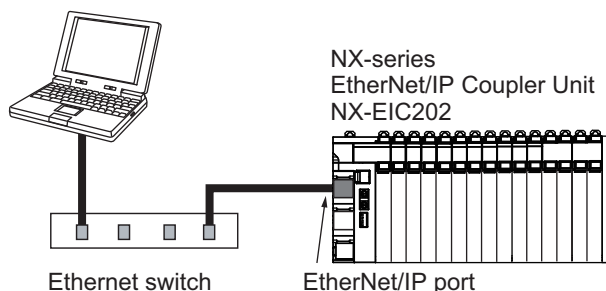

- 1 Right-click **Communication DTM** in the Network View and select **Go online**. Or, select the Communication DTM in the Network View, and then select **Go online** from the Device Menu.
The **Select Interface** Dialog Box is displayed if more than one Ethernet adapter is mounted in the computer.

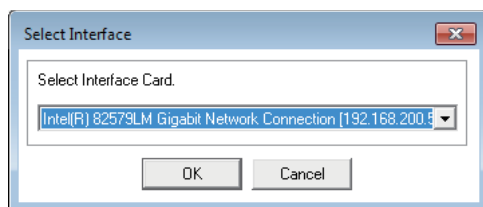

- 2 Select the adapter to use and click the **OK** Button.
If the connection is successful, the **Browse Network** Dialog Box is displayed.

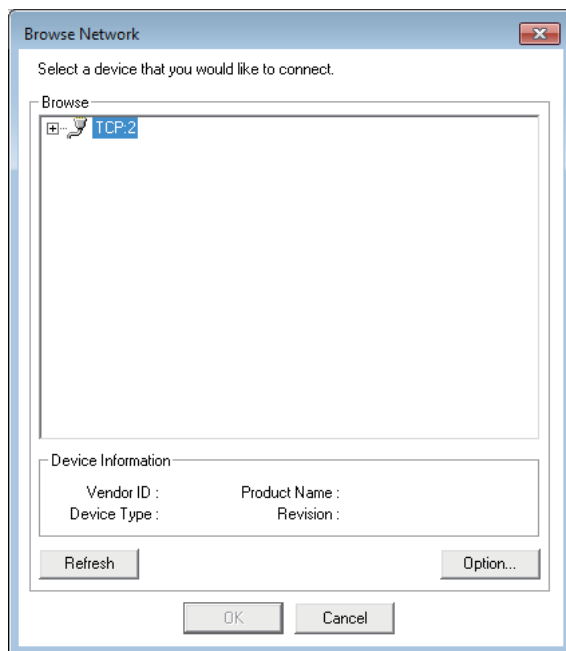

- 3 Set the options as necessary, select **TCP:2** and then click the **OK** Button.
The Support Software goes online.



Precautions for Correct Use

You may need to change the Windows firewall settings when you make the connection for the first time.

Refer to *A-4 Precautions When Using the OMRON EtherNet/IP with CX-ConfiguratorFDT* on page A-39 for the details.

● Ethernet -> CS/CJ1 ETN-EIP Unit I/F

Connection example

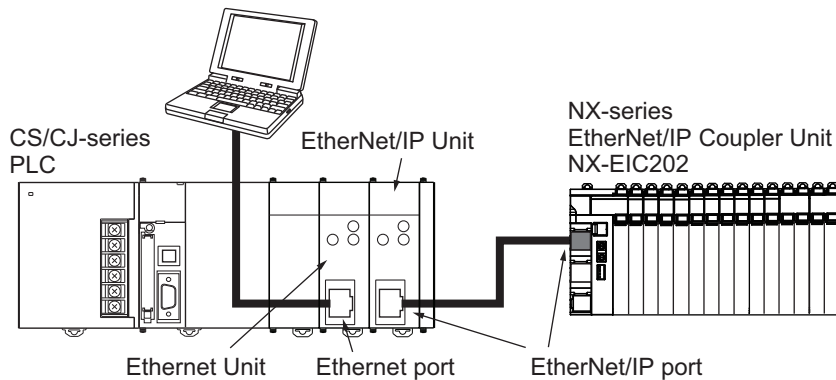

- 1 Right-click **Communication DTM** in the Network View and select **Go online**. Or, select the Communication DTM in the Network View, and then select **Go online** from the Device Menu. The **Select Interface** Dialog Box is displayed if more than one Ethernet adapter is mounted in the computer.

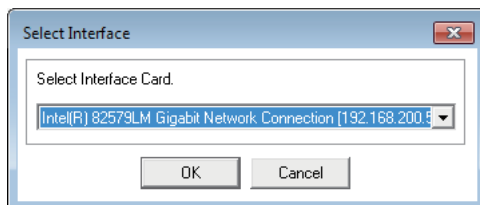

- 2 Select the adapter to use and click the **OK** Button. The **Setup Interface** Dialog Box is displayed.

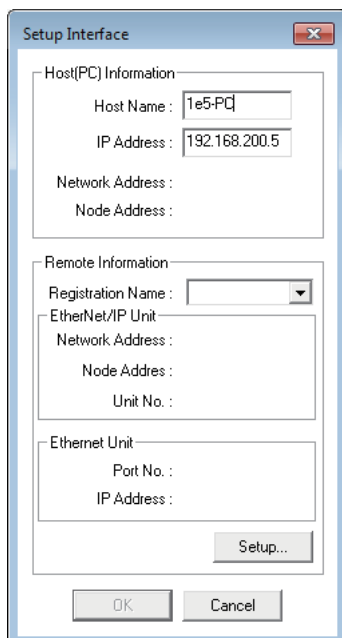

3 Click the **Setup** Button.

The **Registration of the connection** Dialog Box is displayed.

Item	Description
Registration	Name Enter any name.
Host (PC) Information	Enter information on the computer.
Network Address	Enter the same number as the network address of the EtherNet Unit that is mounted on the PLC that serves as a relay node.
Node Address	Enter the last digit of the IP address of the computer. (Example: 1 if the IP address is 192.168.250.1)
Remote Information	
EtherNet/IP Unit	Enter information on the EtherNet/IP Unit that is mounted on the PLC that serves as a relay node.
Network Address	Enter the network address that is set in the routing table.
Node Address	Enter the last digit of the IP address of the Unit. (Example: 3 if the IP address is 192.168.251.3)
Unit No.	Enter the unit number of the CPU Bus Unit (EtherNet/IP Unit).
Ethernet Unit	Enter information on the Ethernet Unit that is mounted on the PLC that serves as a relay node.
Port No.	Enter the Ethernet port number of the Unit.
IP Address	Enter the IP address of the Unit.
Register List	This list shows the registered Units to connect to.
Add Button	Click this to register the Unit settings that you have entered to the Register List as Registration Name.
Delete Button	Click this to delete the Unit with the selected registration name from the Register List.

4 Enter the network information for the Unit to connect to, and then click the **Close** Button.

You return to the **Setup Interface** Dialog Box.

5 Check the registered Unit settings and click the **OK** Button.

If the connection is successful, the **Browse Network** Dialog Box is displayed.

6 Set the options as necessary, select **TCP:2** and then click the **OK** Button.

The Support Software goes online.



Precautions for Correct Use

When the computer and communication DTM are connected in the following connection configuration, you cannot select the same Ethernet adapter in the **Setup Interface** Dialog Box to go online with more than one communication DTM at the same time. Doing so causes the later connection attempts to fail.

Connection configuration:

The computer is connected to one of the following ports through an Ethernet cable and an online connection is established.

- Ethernet port on an Ethernet Unit that is connected to a CS/CJ-series PLC
- EtherNet/IP port on an EtherNet/IP Unit that is connected to a CS/CJ-series PLC
- Built-in EtherNet/IP port on the CS/CJ-series PLC

● **NJ/NX Series USB Port**

Connection example

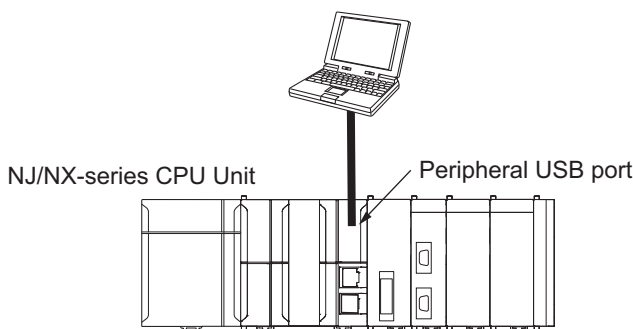

- 1 Right-click **Communication DTM** in the Network View and select **Go online**. Or, select the Communication DTM in the Network View, and then select **Go online** from the Device Menu. If the connection is successful, the **Browse Network** Dialog Box is displayed.

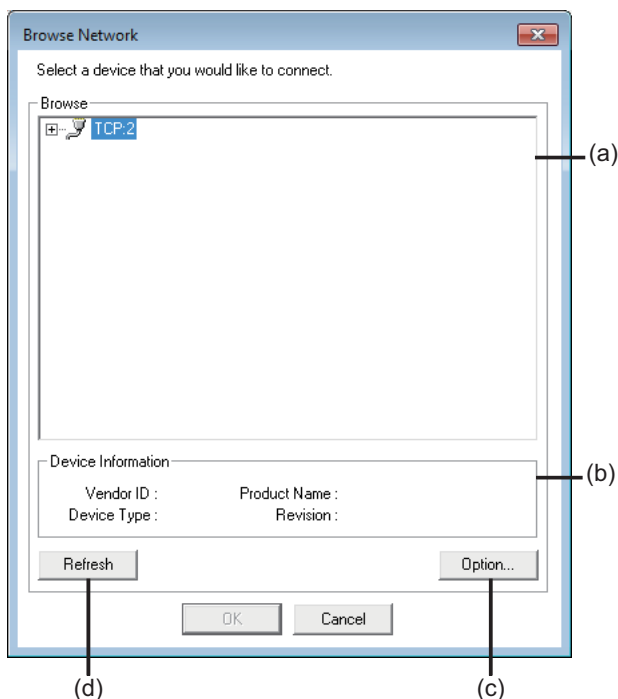

	Item	Description
(a)	Network list	Networks and devices that you can connect to are listed.
(b)	Device Information	Information on the selected device is displayed.
(c)	Option Button	Set the behavior of the network list display function.
(d)	Refresh Button	Click this to update the network list.

- 2** Set the options as necessary, select **TCP:2** and then click the **OK** Button.
The Support Software goes online.



Precautions for Correct Use

You may need to change the Windows firewall settings when you make the connection for the first time.

Refer to *A-4 Precautions When Using the OMRON EtherNet/IP with CX-ConfiguratorFDT* on page A-39 for the details.

● NJ/NX/NY Series Ethernet Direct I/F

Connection example

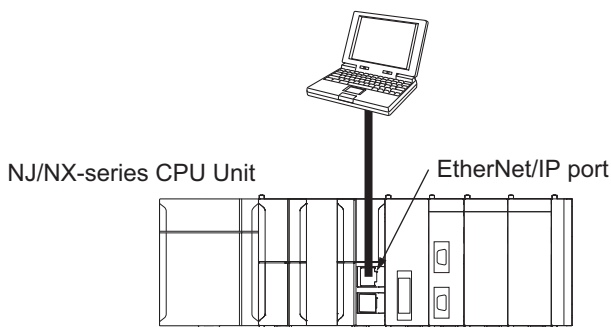

- 1 Right-click **Communication DTM** in the Network View and select **Go online**. Or, select the Communication DTM in the Network View, and then select **Go online** from the Device Menu.
If the connection is successful, the **Browse Network** Dialog Box is displayed.

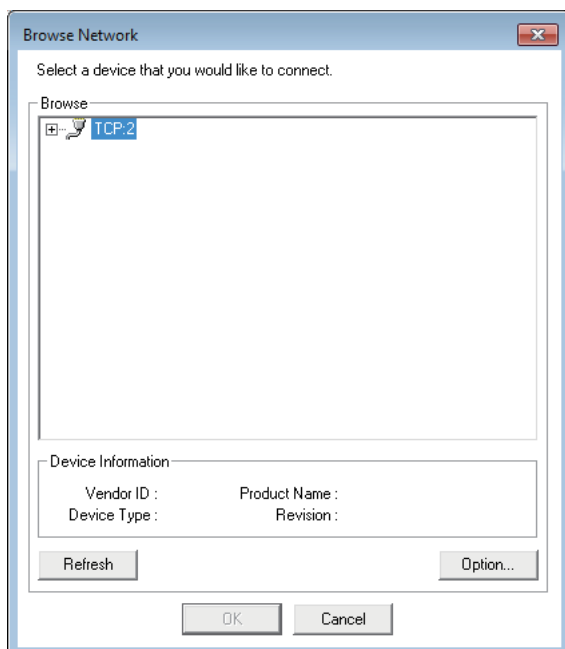

- 2 Set the options as necessary, select **TCP:2** and then click the **OK** Button.
The Support Software goes online.



Precautions for Correct Use

You may need to change the Windows firewall settings when you make the connection for the first time.

Refer to *A-4 Precautions When Using the OMRON EtherNet/IP with CX-ConfiguratorFDT* on page A-39 for the details.

8-4-8 Transferring the IO-Link Device Parameters

This section describes the procedure to transfer the IO-Link device parameters.

Storing the Parameters for an IO-Link Device



Precautions for Correct Use

- You cannot store the parameters in the IO-Link device if *Cycle Read* is set to *Enable* for *Dynamic variables* or *Process data* in the settings for the IO-Link device.
Always set *Cycle Read* to *Disable* if you want to store the Observation/Parameter parameter in the IO-Link device.
- Do not disconnect the cable or turn OFF the power supply to a CPU Unit, Industrial PC, Slave Terminal, or slave when storing parameters from the CX-ConfiguratorFDT to an IO-Link device.

- 1** Right-click the device DTM for the IO-Link device and select **Online Status**.
Devices in the Network View are displayed in bold while you are online.
- 2** Right-click the device DTM again and select **Save to Device**.
The parameter settings are stored in the IO-Link device.

Loading Parameter Settings from IO-Link Devices



Precautions for Correct Use

You cannot load the parameters from the IO-Link device if *Cycle Read* is set to *Enable* for *Dynamic variables* or *Process data* in the settings for the IO-Link device.
Always set *Cycle Read* to *Disable* if you want to load the Observation parameter from the IO-Link device.

- 1** Right-click the device DTM for the IO-Link device and select **Online Status**.
Devices in the Network View are displayed in bold while you are online.
- 2** Right-click the device DTM again and select **Load from Device**.
The parameter settings are uploaded from the IO-Link device.



Precautions for Correct Use

An IO-Link device configuration that is created with the Network View in the CX-ConfiguratorFDT is not compatible with IO-Link Master Unit Configuration Tool parameters or IO-Link Device Configuration Settings created with communications instructions sent to the IO-Link Master Unit.

Always make the configuration settings on the IO-Link Master Unit Configuration Tool.

9

Example of Operations for IO-Link Systems

This section gives examples of IO-Link System operations.

9-1	Assumed Configuration	9-2
9-2	System Configuration Example	9-3
9-3	Controller Communications Setup	9-5
9-4	IO-Link Master Unit Settings	9-6
9-5	Allocating Variables to the I/O Ports	9-7
9-6	Programming	9-9
9-6-1	Reading Input Data from Sensors	9-9
9-7	Turning ON the Power	9-12
9-8	Downloading the Network Configuration Information and the User Program	9-13
9-9	Setting IO-Link Device Parameters and Downloading Them to the IO-Link Devices	9-14
9-10	Confirming the Start of Communications	9-15

9-1 Assumed Configuration

This section describes the following setting and programming examples for the assumed configuration.

- **Reading Sensor Connection Status and Sensor Errors**

- You can read the following status: I/O cable breaks, short-circuit status, and Sensor errors.

- **Reading Input Data from Sensors**

- You can read the following from a Photoelectric Sensor: control output status, unstable detection status, and detected light level.
- You can read the following from a Color Mark Sensor: control output status, unstable detection status, and amount of indecent light.

- **Sensor Setting Operations**

- You can set the sensitivity level of a Photoelectric Sensor.

- **Reading Sensor Status**

- You can read the operating times of Photoelectric Sensors and Color Mark Sensors.

9-2 System Configuration Example

The following example uses one NX-type IO-Link Master Unit and one GX-type IO-Link Master Unit with both IO-Link and non-IO-Link Photoelectric Sensors and Color Mark Sensors as the IO-Link devices.

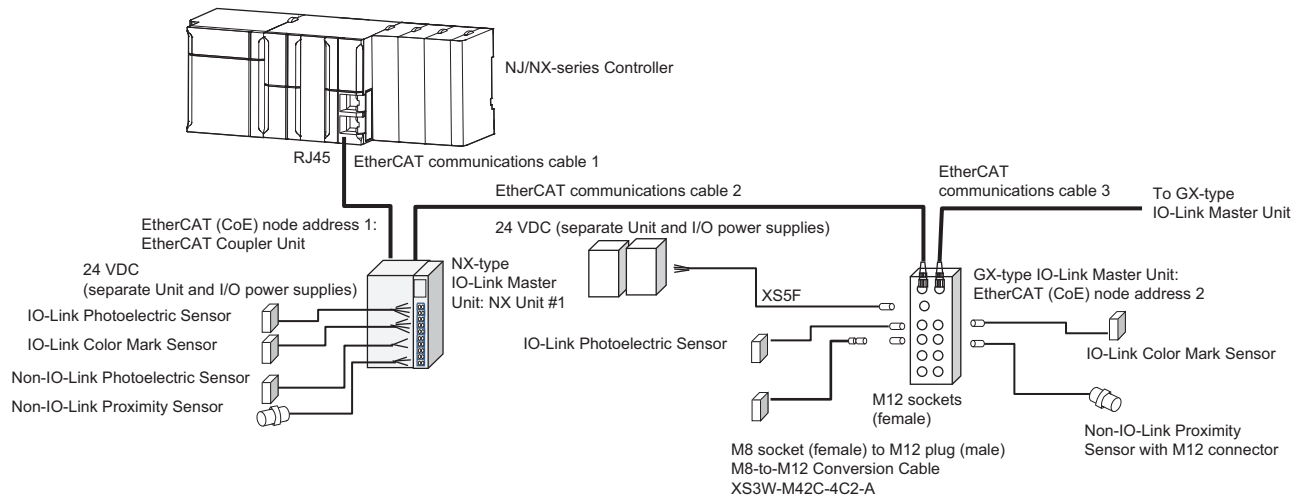

Device type	Name	Specification	Model	Quantity	Configurational settings and connections
Controller	NJ/NX-series Controller	---	NJ101/501 or NX701	1	
IO-Link Master Units	NX-type IO-Link Master Unit	Number of ports: 4	NX-ILM400 (Unit version 1.0)	1	EtherCAT node address 1 is used.
	GX-type IO-Link Master Unit	Number of ports: 8	GX-ILM08C (Unit version 1.0)	1	EtherCAT node address 2 is used.
IO-Link devices	E3Z-series IO-Link Photoelectric Sensor	Prewired	E3Z-D82-IL3	1	Connected to port 1 of the NX-type IO-Link Master Unit.
	IO-Link Color Mark Sensor	---	E3S-DCP21-IL3	1	Connected to port 2 of the NX-type IO-Link Master Unit.
	E3Z-series IO-Link Photoelectric Sensor	Prewired	E3Z-D82-IL3	1	Connected to port 1 of the GX-type IO-Link Master Unit.
	IO-Link Color Mark Sensor	---	E3S-DCP21-IL3	1	Connected to port 2 of the GX-type IO-Link Master Unit.

Device type	Name	Specification	Model	Quantity	Configurational settings and connections
Non-IO-Link devices	E3Z-series General-purpose Photoelectric Sensor	Prewired	E3Z-D81	1	Connected to port 3 of the NX-type IO-Link Master Unit.
	E2E-series General-purpose Proximity Sensor	Prewired	E2E-X1R5E1	1	Connected to port 4 of the NX-type IO-Link Master Unit.
	E3Z-series General-purpose Photoelectric Sensor	M8 plug (male), prewired connector	E3Z-D86	1	Connected to port 3 of the GX-type IO-Link Master Unit.
	E2E-series General-purpose Proximity Sensor	M12 plug (male), prewired connector	E2E-X1R5E1-M1	1	Connected to port 4 of the GX-type IO-Link Master Unit.
EtherCAT cables	(1): Cable with Connectors on Both Ends (RJ45/RJ45)	Standard cable, cable length: 1 m	XS5W-T421-CM D-K	1	
	(2): Cable with Plugs on Both Ends (M12 Straight/RJ45)	Standard cable, cable length: 1 m	XS5W-T421-CM C-SS	1	Connects the NX Coupler Unit and the GX-type IO-Link Master Unit.
	(3): Cable with Plugs on Both Ends (M12 Straight/M12 Straight)	Standard cable, cable length: 1 m	XS5W-T421-CM 2-SS	1	Connects a GX-type IO-Link Master Unit to another GX-type IO-Link Master Unit.
Power supply connector cable	XS5F-series Cable with Connector on One End for M12 Socket	M12 socket on one end (female)	XS5F-D421-C80 -F	1	Connected to the power supply connector of a GX-type IO-Link Master Unit.
Sensor connector conversion cable	M8-to-M12 Conversion Cable	M8 socket (female) to M12 plug (male)	XS3W-M42C-4C 2-A	1	Connected to a Sensor with a prewired connector (M8 plug (male)).
Power supplies	Unit power supply	24 VDC*1			
	I/O power supply	24 VDC*1			

*1. For the methods to calculate the current consumption, refer to 2-3-2 *Calculating the Current Consumption of the IO-Link Master Unit from the I/O Power Supply* on page 2-10.

9-3 Controller Communications Setup

Create an EtherCAT network configuration in a Sysmac Studio project.

Register the following slaves.

- NX-series EtherCAT Coupler Unit
Register the NX-type IO-Link Master Unit in the NX-series EtherCAT Coupler Unit.
- GX-type IO-Link Master Unit

9-4 IO-Link Master Unit Settings

Set parameters and I/O allocations from the Sysmac Studio.

Setting Parameters from the Sysmac Studio

- Set the communications mode for each port.

Setting name	Unit	Port	Set value	Description
Communications mode settings	NX-type IO-Link Master Unit	Port 1	00 hex	IO-Link Mode
		Port 2	00 hex	IO-Link Mode
		Port 3	01 hex	SIO (DI) Mode
		Port 4	01 hex	SIO (DI) Mode
	GX-type IO-Link Master Unit	Port 1	00 hex	IO-Link Mode
		Port 2	00 hex	IO-Link Mode
		Port 3	01 hex	SIO (DI) Mode
		Port 4	01 hex	SIO (DI) Mode

I/O Allocation Settings from the Sysmac Studio

In this example, the sizes of I/O data (process data) for all IO-Link devices are set to the I/O allocation defaults (IO-Link process input data = 2 bytes) for the IO-Link Master Unit. No changes to the I/O allocation settings are required.

9-5 Allocating Variables to the I/O Ports

Use **Configurations and Setup - I/O Map** on the Sysmac Studio to assign variables to the I/O ports of the IO-Link Master Unit.

The following example uses port 1 (Photoelectric Sensor) and port 2 (Proximity Sensor) of an NX-type IO-Link Master Unit.

Checking the Status of the IO-Link Master Unit

In this example, checking is performed for the following errors.

- Device Configuration Verification Error
- IO-Link Communications Error
- I/O Cable Short-circuit
- Error-level Device Event

● I/O Map (Example for an NX-type IO-Link Master Unit)

I/O port	RW	Data type	Variable	Variable comment
▼NX-ILM400				
Port1 Cmp Error	R	BOOL	N1_Port1 Cmp Error	Device Configuration Verification Error
Port1 Comm Error	R	BOOL	N1_Port1 Comm Error	IO-Link Communications Error
Port1 Short Error	R	BOOL	N1_Port1 Short Error	I/O Cable Short-circuit
Port1 Device Error	R	BOOL	N1_Port1 Device Error	Error-level Device Event

IO-Link Process Input Data from E3Z Photoelectric Sensors, and I/O Map

The allocation of the IO-Link process input data and the I/O Map in the E3Z photoelectric sensor are as described below.

● Allocation of IO-Link Process Input Data

PD0							
7	6	5	4	3	2	1	0
Detected light level monitor output							
PD1							
7	6	5	4	3	2	1	0
Major error	Minor error	Not used (0)	Instability Alarm (Non-Light Receiving)	Instability Alarm (Light Receiving)	Not used (0)	Sensor output 2	Sensor output 1

- I/O Map (Example for an NX-type IO-Link Master Unit)

I/O port	RW	Data type	Variable	Variable comment
▼NX-ILM400				
▼Port1_Input_Data_01	R	ARRAY[0..1]OF BYTE	IO_LinkData1	
[0]	R	BYTE	IO_LinkData1 [0]	PD0
[1]	R	BYTE	IO_LinkData1 [1]	PD1

IO-Link Process Input Data from the E3S Color Mark Sensor, and I/O Map

The allocation of the IO-Link process input data and the I/O Map in the E3S Color Mark sensor are as described below.

- Allocation of IO-Link Process Input Data

	Bit							
	7	6	5	4	3	2	1	0
PD0	--- (Not used.)	--- (Not used.)	--- (Not used.)	--- (Not used.)	--- (Not used.)	B light emission	G light emission	R light emission
PD1	Major error	Minor error	--- (Not used.)	--- (Not used.)	Instability alarm	--- (Not used.)	Control output 2	Control output 1
PD2	Always 0 (Not used.)				R detected light level monitor output, upper 4 bits			
PD3	R detected light level monitor output, lower 8 bits							
PD4	Always 0 (Not used.)				G detected light level monitor output, upper 4 bits			
PD5	G detected light level monitor output, lower 8 bits							
PD6	Always 0 (Not used.)				B detected light level monitor output, upper 4 bits			
PD7	B detected light level monitor output, lower 8 bits							

- I/O Map (Example for an NX-type IO-Link Master Unit)

Description	R/W	Data type	Variable name	Variable comment
▼NX-ILM400				
▼Port1_Input_Data_01	R	ARRAY[0..1]OF BYTE	ColorMarkStatus	
[0]	R	BYTE	ColorMarkStatus[0]	PD0
[1]	R	BYTE	ColorMarkStatus[1]	PD1
▼Port1_Input_Data_02	R	ARRAY[0..1]OF BYTE	R_Data	
[0]	R	BYTE	R_Data[0]	PD2
[1]	R	BYTE	R_Data[1]	PD3
▼Port1_Input_Data_03	R	ARRAY[0..1]OF BYTE	G_Data	
[0]	R	BYTE	G_Data[0]	PD4
[1]	R	BYTE	G_Data[1]	PD5
▼Port1_Input_Data_04	R	ARRAY[0..1]OF BYTE	B_Data	
[0]	R	BYTE	B_Data[0]	PD6
[1]	R	BYTE	B_Data[1]	PD7

9-6 Programming

The following operations are programmed.

- Reading input data from Sensors
- Sensor setting operations and reading Sensor status

9-6-1 Reading Input Data from Sensors

Use the I/O data to check sensor control output status, unstable detection status, the amount of incident light, etc.

A sample programming for reading input data is given below.

Conditions for Reading Input Data

Use the following flags as conditions to read and use the input data.

● NX-type IO-Link Master Unit

- NX Unit I/O Data Active Status

Connecting the NX-type IO-Link Master Unit to a Communications Coupler Unit: E001_NX-
_Unit_IO_Data_Active_Status_15^{*1}

Connecting the NX-type IO-Link Master Unit to a CPU Unit: NXBus_N1_NX_Unit_I_O_Data_Active_Status

- Input Data Enabled Flag: N1_Port*_IN_Data_Enable^{*2}

*1. "E001_" is attached to the names of device variables that are automatically generated. "15" indicates a flag that tells whether I/O data is usable for 15 mounted NX Units.

*2. "N1_" is attached to device variables that are automatically generated from the mounting sequence of the NX Units. The asterisk indicates where the port number of the IO-Link Unit is input.

Example:

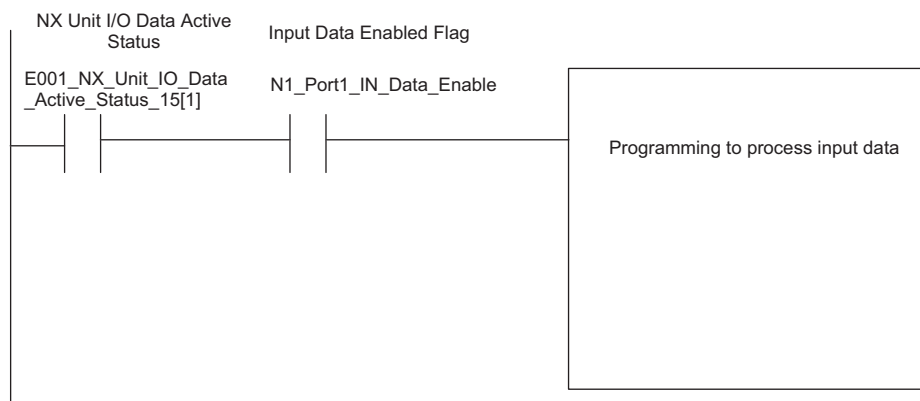

● GX-type IO-Link Master Unit

- Process Data Communicating Slave Table: `_EC_PDslavTbl[2]`^{*1}
- Input Data Enabled Flag: `E002_Port*_IN_Data_Enable`^{*2}

*1. “[2]” is the EtherCAT node address.

*2. “E002_” is attached to the names of device variables that are automatically generated. The asterisk indicates where the port number of the IO-Link Master Unit is input.

Example:

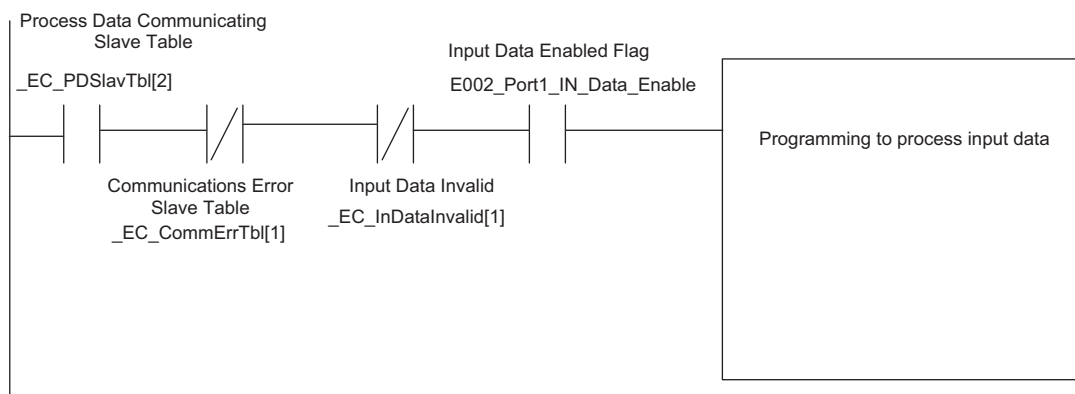

Programming for Photoelectric Sensors

A programming example for 9-5 *Allocating Variables to the I/O Ports* on page 9-7 is given below.

● Reading the Detected Light Level

The detected light level is read as a BYTE array device variable and converted to USINT.

```
Light_Received*1 := BYTE_TO_USINT( LineA_Sensor[0] );
```

*1. *Light_Received* is an USINT internal variable.

● Reading Bit Status

The Bit Test (TestABit) instruction is used to read sensor output 2.

```
SensorOutput2*1 := TestABit( LineA_Sensor[1], 1 );
```

*1. *SensorOutput2* is a BOOL internal variable.

Programming for Color Mark Sensors

A programming example for 9-5 *Allocating Variables to the I/O Ports* on page 9-7 is given below.

● Reading the R Detected Light Level

The Pack Word (PackWORD) instruction is used when reading the detected light level to join two byte variables into one WORD variable.

```
R_Data_Word*1 := PackWORD( R_Data[0], R_Data[1] );
```

*1. *R_Data_Word* is a WORD internal variable.

Sensor Setting Operations and Reading Sensor Status

Use communications instructions to execute sensor setting operations and read internal status.

● Setting the Sensitivity Level of a Photoelectric Sensor.

Use the IO-Link Write Device Object instruction.

For the sensitivity level, specify 67 decimal as the index number.

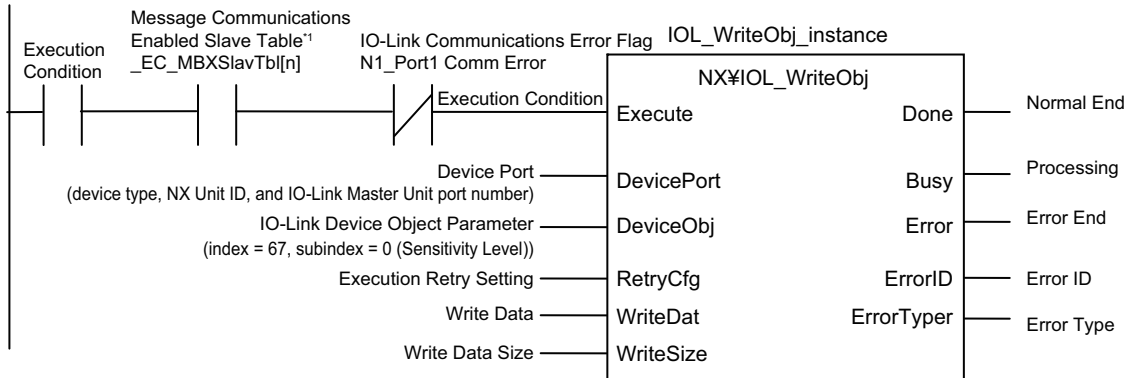

*1. Use this when you connect the IO-Link Master Unit to a Communications Coupler Unit. This is not necessary when you connect the IO-Link Master Unit to a CPU Unit.

● Reading the Operating Times of Photoelectric Sensors and Color Mark Sensors

Use the IO-Link Read Device Object instruction.

For the operating times of both Photoelectric Sensors and Color Mark Sensors, specify 160 decimal as the index number.

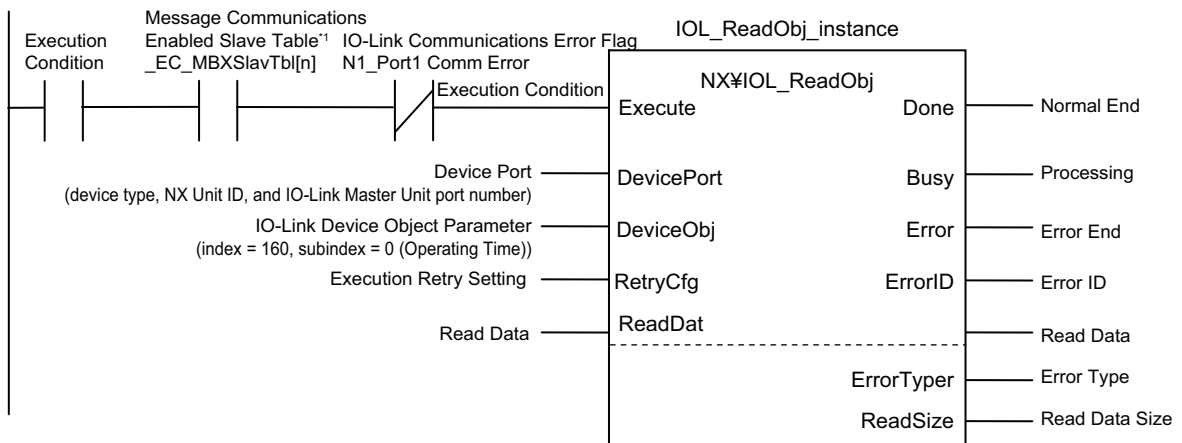

*1. Use this when you connect the IO-Link Master Unit to a Communications Coupler Unit. This is not necessary when you connect the IO-Link Master Unit to a CPU Unit.

9-7 Turning ON the Power

Turn ON the power of the entire system.

Turn ON the following Unit power and I/O power.

- NJ/NX-series CPU Unit
- EtherCAT Coupler Unit
- IO-Link Master Unit

9-8 Downloading the Network Configuration Information and the User Program

Download the network configuration information, slave terminal setting information ^{*1}, and the user program from the Sysmac Studio to the NJ/NX-series CPU Unit.

Use the Synchronization function of Sysmac Studio for download.

The network configuration information indicates the setting information of the EtherCAT slave.

The slave terminal setting information indicates the unit configuration information or I/O allocation information, unit operation settings, and unit application data.

9-9 Setting IO-Link Device Parameters and Downloading Them to the IO-Link Devices

Start CX-Configurator FDT, create a Network View, and set the IO-Link device parameters.

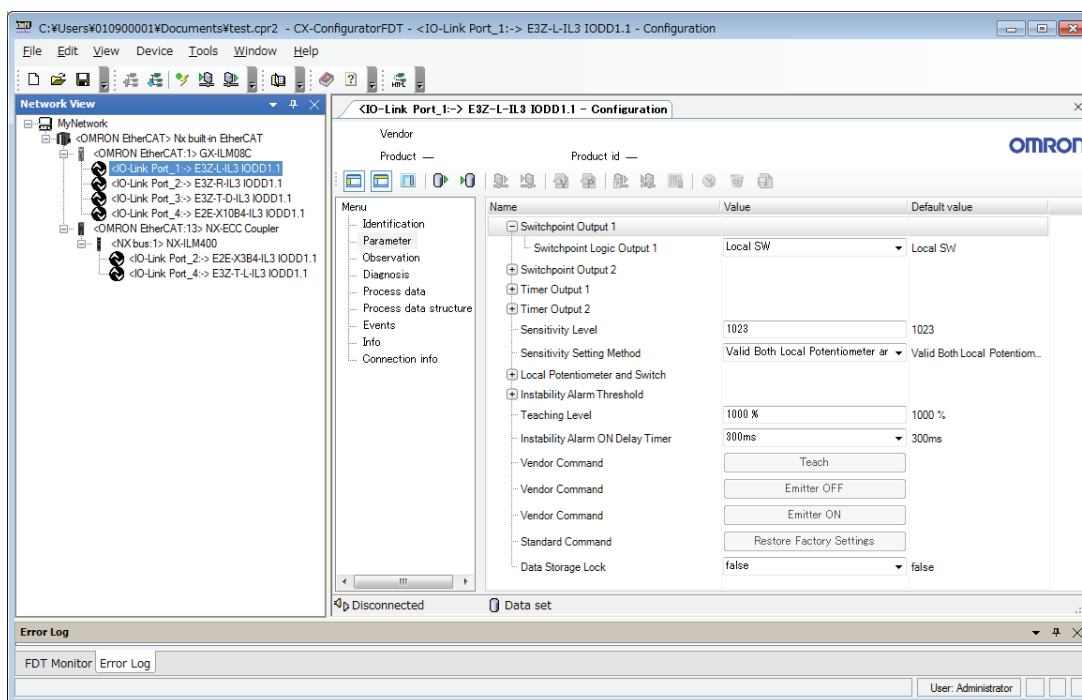

9-10 Confirming the Start of Communications

Use the front panel indicators on the IO-Link Master Unit to check whether communications have started. Communications have started normally for the following indicator status.

NX-type IO-Link Master Unit: The C indicator lights green and the E indicator is not lit.

GX-type IO-Link Master Unit: The C/E indicator lights green.

Troubleshooting for IO-Link Systems

This section describes troubleshooting for IO-Link Systems.

10-1 IO-Link Error and Device Error Notifications and Checking Methods	10-2
10-1-1 Overview	10-2
10-1-2 Checking for Errors	10-6
10-1-3 Error Notification with the I/O Port Error Status in the I/O Data	10-7
10-1-4 Error Notification with the Sysmac Error Status in the I/O Data	10-7
10-1-5 Error Notification with Emergency Messages (GX-type IO-Link Master Units Only)	10-8
10-1-6 Error Notifications Based on the AL Status (GX-type IO-Link Master Units Only)	10-10
10-1-7 Checking for Errors and Troubleshooting with the Indicators on the Front Panel of the IO-Link Master Unit	10-12
10-1-8 Assumed Causes and Corrections for Other Errors	10-17
10-2 Checking for Errors and Troubleshooting with Tools	10-18
10-2-1 Checking for Errors from the Sysmac Studio	10-18
10-2-2 Checking for Errors from Support Software Other Than the Sysmac Studio	10-19
10-2-3 Sysmac Event Codes and Troubleshooting	10-20
10-2-4 Reading Event Logs from a Tool	10-46
10-2-5 Clearing Event Logs from a Tool	10-47
10-2-6 Exporting Event Logs from a Tool	10-48
10-3 Backing Up Settings and Replacing Units	10-49
10-3-1 Backup and Restore Methods	10-49
10-3-2 Replacing the IO-Link Master Unit or IO-Link Devices	10-51
10-3-3 Replacing the IO-Link Master Unit and IO-Link Devices at the Same Time	10-53

10-1 IO-Link Error and Device Error Notifications and Checking Methods

10-1-1 Overview

You can use the following methods to check the status of IO-Link errors and device errors from the IO-Link Master Unit with the controller or IO-Link Master Unit Configuration Tool.

Controller Communications with EtherCAT

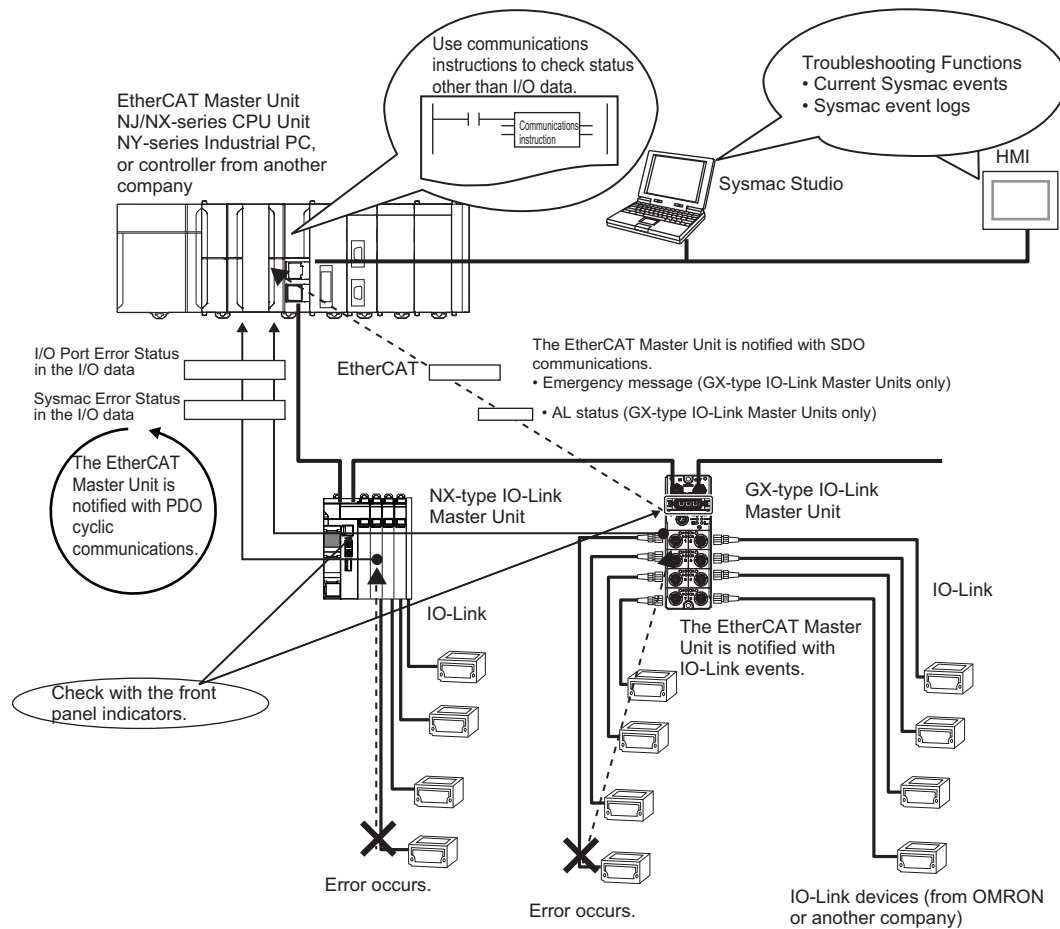

Notification method	Overview	Notification and confirmation method	IO-Link Master Unit		Reference
			NX	GX	
I/O Port Error Status in the I/O data	This status indicates errors detected by the IO-Link Master Unit for each port.	Cyclic communications are used to notify the controller of errors. Check the I/O data of the IO-Link Master Unit with Support Software ^{*1} that can monitor.	Yes	Yes	10-1-3 Error Notification with the I/O Port Error Status in the I/O Data on page 10-7
Sysmac Error Status in the I/O data	This status indicates the level of Sysmac errors that occur in the IO-Link Master Unit. ^{*2}	Cyclic communications are used to notify the controller of errors.	Yes	Yes	10-1-4 Error Notification with the Sysmac Error Status in the I/O Data on page 10-7
Sysmac events	Sysmac events are received from the IO-Link Master Unit.	You can use the Sysmac Studio ^{*3} or HMI troubleshooting functions ^{*4} to check the following: Current Sysmac events and a log of past Sysmac events, event sources, causes, and corrections.	Yes	^{*5}	10-2 Checking for Errors and Troubleshooting with Tools on page 10-18
		You can read the relevant CoE objects with SDO communications instructions to check the following: Current Sysmac events and a log of past Sysmac events.	Yes	Yes	<ul style="list-style-type: none"> For NX-type <i>NX-series EtherCAT Coupler Unit User's Manual</i> (Cat. No. W519-E1-09 or later). For GX-type <i>GX-series EtherCAT Slave Unit User's Manual</i> (Cat. No. W488).
Emergency message (GX-type IO-Link Master Units only)	When an error occurs, the IO-Link Master Unit notifies the EtherCAT Master Unit.	The IO-Link Master Unit reports application-level errors to the EtherCAT Master Unit with SDO communications. You can also check for application-level errors as Sysmac events from the Sysmac Studio.	No	Yes	10-1-5 Error Notification with Emergency Messages (GX-type IO-Link Master Units Only) on page 10-8
AL status (GX-type IO-Link Master Units only)	When an error occurs, the error is written to the AL status register to notify the EtherCAT master.	This status reports errors related to EtherCAT communications. You can also check for application-level errors as Sysmac events from the Sysmac Studio.	No	Yes	10-1-6 Error Notifications Based on the AL Status (GX-type IO-Link Master Units Only) on page 10-10

Notification method	Overview	Notification and confirmation method	IO-Link Master Unit		Reference
			NX	GX	
Checking the indicators on the IO-Link Master Unit and the IO-Link devices	You can check the status and whether errors occur in general in the IO-Link Master Unit and the IO-Link devices.	---	Yes	Yes	10-1-7 Checking for Errors and Troubleshooting with the Indicators on the Front Panel of the IO-Link Master Unit on page 10-12

- *1. When you use a controller from another company, check with the Support Software corresponding to that controller.
- *2. This status provides OR values of errors that occur in the EtherCAT Coupler Unit and NX Units when using an NX-type IO-Link Master Unit.
- *3. When you use a controller from another company, connect the Sysmac Studio to the USB port on the EtherCAT Coupler Unit to check.
- *4. When you use a controller from another company, you cannot use the HMI troubleshooting functions.
- *5. It is possible for an NJ/NX-series CPU Unit or NY-series Industrial PC, but not possible for a controller from another company.

Controller Communications with EtherNet/IP

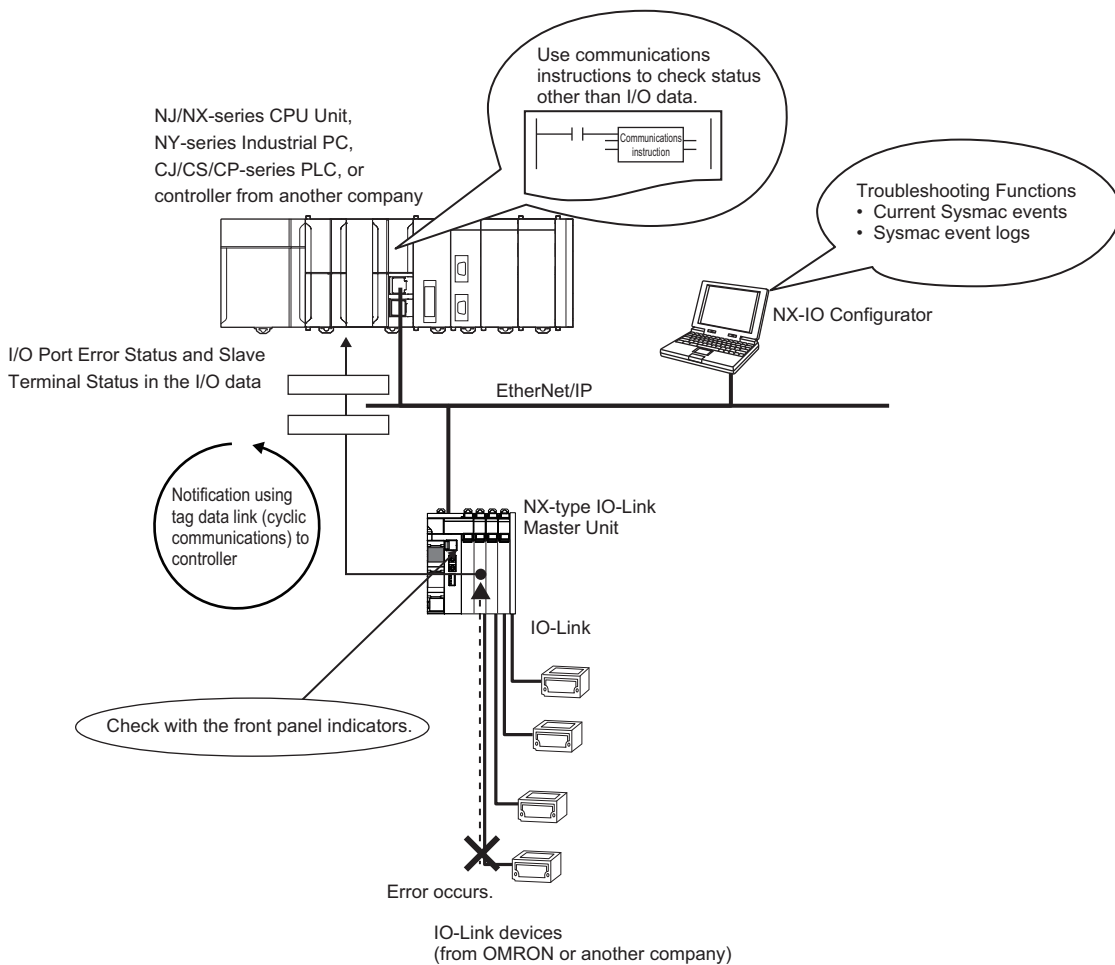

Notification method	Overview	Notification and confirmation method	Reference
I/O Port Error Status in the I/O data	This status indicates errors detected by the IO-Link Master Unit for each port.	Cyclic communications are used to notify the controller of errors. Check the I/O data of the IO-Link Master Unit with Support Software ^{*1} that can monitor.	10-1-3 Error Notification with the I/O Port Error Status in the I/O Data on page 10-7
Slave Terminal Status in the I/O data	Indicates the status of the EtherNet/IP Slave Terminal.	Cyclic communications are used to notify the controller of the status of the EtherNet/IP Slave Terminal.	NX-series EtherNet/IP Coupler Unit User's Manual (Cat. No. W536)
Sysmac events	Sysmac events are received from the IO-Link Master Unit.	The following can be checked with the IO-Link Master Unit Configuration Tool troubleshooting functions ^{*2} and event log acquisition CIP service. Current Sysmac events and a log of past Sysmac events, event sources, causes, and corrections.	10-2 Checking for Errors and Troubleshooting with Tools on page 10-18
		You can read the relevant CIP objects with an event log acquisition CIP service to check the following: Current Sysmac events and a log of past Sysmac events.	NX-series EtherNet/IP Coupler Unit User's Manual (Cat. No. W536-E1-04 or later)
Checking the indicators on the IO-Link Master Unit and the IO-Link devices	You can check the status and whether errors occur in general in the IO-Link Master Unit and the IO-Link devices.	---	10-1-7 Checking for Errors and Troubleshooting with the Indicators on the Front Panel of the IO-Link Master Unit on page 10-12

*1. When you use a controller from another company, check with the Support Software corresponding to that controller.

*2. Troubleshooting functions with the Support Software can also be used by connecting to the USB port on the EtherNet/IP Coupling Unit. Sysmac Studio can be used only with that connection.

Controller Communications with NX Bus

Notification method	Overview	Notification and confirmation method	Reference
Port Error Status in the I/O data	This status indicates errors detected by the IO-Link Master Unit for each port.	Cyclic communications are used to notify the controller of errors. You can check for errors with the user program or the monitor function of the Sysmac Studio.	10-1-3 Error Notification with the I/O Port Error Status in the I/O Data on page 10-7
Sysmac events	Sysmac events are received from the IO-Link Master Unit.	You can use the Sysmac Studio or HMI troubleshooting functions to check the following: Current Sysmac events and a log of past Sysmac events, event sources, causes, and corrections.	10-2 Checking for Errors and Troubleshooting with Tools on page 10-18

Notification method	Overview	Notification and confirmation method	Reference
Checking the indicators on the IO-Link Master Unit and the IO-Link devices	You can check the status and whether errors occur in general in the IO-Link Master Unit and the IO-Link devices.	---	<i>10-1-7 Checking for Errors and Troubleshooting with the Indicators on the Front Panel of the IO-Link Master Unit on page 10-12</i>

For details on the NX Unit statuses that the NX Bus Function Module of the CPU Unit manages, refer to the software user's manual for the connected CPU Unit.

10-1-2 Checking for Errors

Use the following procedure to check for errors.

1 Use the IO-Link Master Unit Configuration Tool to check for errors in the IO-Link Master Unit.

2 If there is an error in the IO-Link Master Unit, check the following items to isolate the cause of the error.

- Check the indicators.
- Check the I/O Port Error Status in the I/O data.
- Check for errors with the Support Software.

Performing troubleshooting from the IO-Link Master Unit Configuration Tool to check for errors.

For EtherCAT communications and Support Software from another company, use the emergency messages and AL status to check for errors.

- Check with messages.

For the EtherCAT, with SDO communications instructions, read CoE objects which can read current Sysmac events to check the errors.

For the EtherNet/IP, with an event log acquisition CIP service, read CIP objects which can read current Sysmac events to check the errors.

10-1-3 Error Notification with the I/O Port Error Status in the I/O Data

The I/O Port Error Status in the IO-Link data provides cyclic notifications to the controller of errors that occur in the ports on the IO-Link Master Unit.

Refer to *Section 4 I/O Data* for details.

10-1-4 Error Notification with the Sysmac Error Status in the I/O Data

You can use the Sysmac Error Status in the IO-Link data to provide cyclic notifications to the EtherCAT Master Unit of the levels of errors that occur in the IO-Link Master Unit.

Detecting Errors with System-defined Variables or Device Variables

For NJ/NX-series CPU Units or NY-series Industrial PCs, you can detect the occurrence of errors based on the Sysmac Error Status with a system-defined variable (`_EC_SlavErr`) or an IO-Link Master Unit device variable (Sysmac Error Status).

Clearing Errors

For an error that is detected for the Sysmac Error Status, the error status is retained even if the cause of the error is eliminated. You can write 1 to the Sysmac Error Status Area object (index: 2002 hex, subindex: 02 hex) to clear the error status detected by the IO-Link Master Unit.

You can clear the error status detected by the IO-Link Master Unit with a special instruction to reset errors if the controller is an NJ/NX-series CPU Unit or NY-series Industrial PC, or by clearing all errors from the Troubleshooting Dialog Box in the Sysmac Studio.

Sysmac Event Code Confirmation and Troubleshooting

If an error occurs, you can use the EtherCAT Master Unit to check current errors for each Sysmac Error Status level.

You can use the Sysmac Error Status to check for errors in the range that is managed by the IO-Link Master Unit.

You can connect the Sysmac Studio to an NJ/NX-series CPU Unit or NY-series Industrial PC to check Sysmac event codes in the Troubleshooting Dialog Box (Controller Error Tab Page) to confirm what errors were detected by the IO-Link Master Unit. Refer to *10-2-3 Sysmac Event Codes and Troubleshooting* on page 10-20 for Sysmac event codes.

For the master from another company, you can read the relevant CoE objects to check the details of errors that occur. For example, for a GX-type master, you can read index number 2003 hex and 2004 hex to check. For details on the relevant CoE objects, refer to the *NX-series EtherCAT Coupler Unit User's Manual* (Cat. No. W519-E1-09 or later) for an NX-type master and the *GX-series EtherCAT Slave Unit User's Manual* (Cat. No. W488) for a GX-type master.

10-1-5 Error Notification with Emergency Messages (GX-type IO-Link Master Units Only)

If an EtherCAT slave error occurs, you can send messages from the slave to the master using slave-initiated communications.

What Is an Emergency Message?

An emergency message is a message that is sent from the slave using SDO communications when an application-level error occurs in the EtherCAT slave.

For IO-Link Systems, you can send an emergency message if an error occurs in an IO-Link device, such as an IO-Link communications error.

This is possible for GX-type IO-Link Master Units only. You cannot send an emergency message with an NX-type IO-Link Master Unit.

If a GX-type IO-Link Master Unit detects an applicable error, it notifies the EtherCAT Master Unit with an emergency message.

Every time the Unit power supply is turned ON, the IO-Link Master Unit is started with emergency message communications enabled.

Emergency messages cannot be sent while there is an EtherCAT communications error.

Emergency Message Detected Event

If an NJ/NX-series CPU Unit or NY-series Industrial PC detects that an emergency message was sent from the EtherCAT Coupler Unit or the GX-type IO-Link Master Unit, an Emergency Message Detected event (Sysmac event code: 64200000 hex) occurs.

If this event occurs, you can place the Sysmac Studio online with the NJ/NX-series CPU Unit or NY-series Industrial PC and check the emergency message (including the emergency error code) in attached information 1 to attached information 3 in the Emergency Message Detected event in the Troubleshooting Dialog Box.

If an Emergency Message Detected event occurs, the `_EC_SlavEmergErr` system-defined variable (Emergency Message Detected) changes to TRUE. Therefore, you can use the user program to check whether the slave has sent an emergency message.

Contents of Emergency Messages

An emergency message is composed of 8-byte data as shown below.

Byte	0	1	2	3	4	5	6	7	
Contents	Emergency error code		Reserved		Sysmac event code				

List of Emergency Error Codes

The following table lists the emergency error codes that are used by GX type IO-Link Units, and the corrections for the errors.

Emergency error code (hex)	Error name	Description	Error record	Notification to EtherCAT Master Unit	Correction
5530	Non-volatile Memory Hardware Error	A timeout was detected when writing data to non-volatile memory during EtherCAT communications.	Not recorded.	Can be notified.	Write the data again.
6140	Slave Unit Verification Error	When the power supply was turned ON, a verification error occurred for the slave information stored in the Slave Unit.	Recorded.	Cannot be notified.	If the error still occurs after cycling the power supply, the Slave Unit is faulty. Replace the Slave Unit.
6330	Non-volatile Memory Checksum Error	An error occurred in the data in non-volatile memory in the slave.	Recorded.	Can be notified.	There is an error in the data in the non-volatile memory. Use the Configuration Tool or SDO communications to initialize the non-volatile memory, and then restart the slave. (Applicable index: 1011 hex (Restore Default Parameters))
7030	Slave Hardware Error	A hardware error occurred in the EtherCAT communications section.	Recorded.	Cannot be notified.	If the error still occurs after cycling the power supply, the Slave Unit is faulty. Replace the Slave Unit.
FF01 to FF08 (correspond to port 1 to port 8)	IO-Link Communications Error	A fatal error occurred in IO-Link communications.	Recorded.	Can be notified.	<ul style="list-style-type: none"> • Check the I/O cable to see if it is broken. Or • Replace the IO-Link device. Or • Implement noise countermeasures. Or • Replace the IO-Link Master Unit.
FF21 to FF28 (correspond to port 1 to port 8)	Device Configuration Verification Error	These error codes indicate that the connected IO-Link devices do not match the configuration settings.	Recorded.	Can be notified.	Connect the IO-Link device registered for the port of the IO-Link Master.
FF41 to FF48 (correspond to port 1 to port 8)	I/O Cable Short-circuit	These codes indicate short-circuits in the I/O cable.	Recorded.	Can be notified.	<ul style="list-style-type: none"> • Check to see if there is a short-circuit in the I/O cable. Or • Replace the IO-Link device.
FF61 to FF68 (correspond to port 1 to port 8)	Device Event	These error codes indicate that error-level events were reported from the IO-Link devices.	Recorded.	Can be notified.	Confirm the IO-Link event code of the IO-Link device from CX-ConfiguratorFDT, and refer to the manual for the IO-Link device to perform troubleshooting.

You can isolate the causes of errors from the emergency error codes.

Emergency messages cannot be sent while there is an EtherCAT communications error.

Refer to *10-2-3 Sysmac Event Codes and Troubleshooting* on page 10-20 for Sysmac event codes.

The Emergency Message Error Log and How to Read It

A log of the errors that were reported with emergency messages is saved in the following location.

You can read the saved emergency messages with SDO communications instructions.

Type	Save location of error log	Number of messages saved
GX-type IO-Link Master Unit	Non-volatile memory of the GX-type IO-Link Master Unit	Maximum of 64 messages

The indexes to read with SDO communications instructions are from subindexes 06 to 45 hex (Diagnosis Messages 1 to 64) in index 10F3 hex (Diagnostic History).

The emergency message log saves messages sequentially starting from the new message number (10F3:02). The count returns to Diagnosis Message 1 after Diagnosis Message 64. Even if an emergency message cannot be sent to the EtherCAT master, it is still saved in the error log. Errors related to the non-volatile memory are not saved in the error log.

10-1-6 Error Notifications Based on the AL Status (GX-type IO-Link Master Units Only)

For a GX-type IO-Link Master Unit, the EtherCAT Master Unit can detect errors in the Unit with the AL status if an EtherCAT communications errors occurs.

For an NJ/NX-series CPU Unit or NY-series Industrial PC, a Slave Application Error event (Sysmac event code: 84280000 hex) occurs when an AL status error occurs in the GX-type IO-Link Master Unit.

If you connect the NJ/NX-series CPU Unit or NY-series Industrial PC and the Sysmac Studio, you can find the following AL status codes in attached information 1 for Slave Application Error events in the Troubleshooting Window. You can isolate the causes of errors from these AL status codes.

AL status code	Name	Cause	Correction
0001 hex	State Transition Impossible	The number of received state transition requests exceeded the limit set by the application. <ul style="list-style-type: none"> A fatal error occurred. Operation was synchronized in DC Mode. 	An error occurred in the EtherCAT slave. Check the indicator status.
0011 hex	Illegal State Transition Request Received	An incorrect state transition request was received.	Change the status correctly.
0012 hex	Error State Transition Received	An unclear state transition request was received.	Change the status correctly.
0014 hex	Slave Unit Verification Error	The non-volatile memory for SII backup does not match the information in the SII (vendor ID, product code, IO-Link revision, and serial number).	Cycle the power supply. If the error still occurs, replace the CPU Unit.
0016 hex	Mailbox Setting Error	An incorrect mailbox setting was detected for the Sync Manager.	Correct the settings, and then download the settings to the EtherCAT Master Unit again.

AL status code	Name	Cause	Correction
001B hex	Process Data WDT Error	A timeout was detected for an I/O data send frame.	Review the following items, and restart the slave based on the specifications of the connected EtherCAT master. <ul style="list-style-type: none"> • Wire the EtherCAT communications cable correctly. • Check to see if the EtherCAT communications cable is exposed to excessive noise.
001D hex	RxPDO Setting Error	An error was detected in the RxPDO settings.	Correct the settings, and then download the settings to the EtherCAT Master Unit again.
001E hex	TxPDO Setting Error	An error was detected in the TxPDO settings.	Correct the settings, and then download the settings to the EtherCAT Master Unit again.
001F hex	PDO WDT Setting Error	An incorrect PDO WDT setting was detected.	Correct the settings, and then download the settings to the EtherCAT Master Unit again.
0021 hex	Init State Transition Request	The slave sent a request to the EtherCAT master for a transition to the Init state.	Restart communications after changing the slave to the Init state.
0024 hex	TxPDO Mapping Error	An illegal TxPDO was set. <ul style="list-style-type: none"> • An incorrect TxPDO was set, e.g., the index, subindex, or size was outside of the allowable range. 	Correct the settings, and then download the settings to the EtherCAT Master Unit again.
0025 hex	RxPDO Mapping Error	An illegal RxPDO was set. <ul style="list-style-type: none"> • An incorrect RxPDO was set, e.g., the index, subindex, or size was outside of the allowable range. 	Correct the settings, and then download the settings to the EtherCAT Master Unit again.
0028 hex	SM Event Mode Setting Error	An SM Event Mode that is not supported was set.	Correct the settings, and then download the settings to the EtherCAT Master Unit again.
0029 hex	Buffer Mode Setting Error	Three buffers were not set.	Correct the settings, and then download the settings to the EtherCAT Master Unit again.

10-1-7 Checking for Errors and Troubleshooting with the Indicators on the Front Panel of the IO-Link Master Unit

You can use the indicators on the IO-Link Master Unit to check the Unit status and level of errors.

The indicator status, IO-Link Master Unit status, and corrections for errors are given in the following table.

NX-type IO-Link Master Unit

TS		C		E		Unit status	Cause	Correction
Green	Red	Green	Red	Green	Red			
Lit	Not lit	Lit	Not lit	The Unit is operating normally.		---	---	
				<ul style="list-style-type: none"> • Communications with the Communications Coupler Unit are possible. • IO-Link communications are possible in IO-Link Mode. 				
		Not lit	Not lit	The Unit is operating normally.		---	---	
				<ul style="list-style-type: none"> • IO-Link communications are stopped in IO-Link Mode. • IO-Link Mode is not used. 				
Not lit	Lit	I/O power supply error		There is insufficient or no I/O power supply.	Check the following items and correct the I/O power supply. Make sure that the power supply cable is wired correctly. Make sure that there are no breaks in the power supply cable. Make sure that the power supply voltage is within the specified range. Make sure that the power supply has enough capacity. Make sure that the power supply has not failed.			
		A hardware error or other critical error has occurred in the IO-Link port.		A hardware error has occurred.	Replace the Unit.			

TS		C		E		Unit status	Cause	Correction
Green	Red	Green	Red	Green	Red			
Lit	Not lit	Not lit	Flashes at 0.5-s intervals.	One of the following occurred in IO-Link Mode.				
				• IO-Link communications error	• The I/O cable is broken. • An IO-Link device has failed. • IO-Link Master Unit failure	• Check the I/O cable to see if it is broken. Or • Replace the IO-Link device. Or • Implement noise countermeasures.		
				• I/O cable short-circuit	• There is a short-circuit in the I/O cable. • An IO-Link device has failed.	• Check to see if there is a short-circuit in the I/O cable. Or • Replace the IO-Link device.		
				• Device configuration verification error	• The connected IO-Link device does not agree with the registered information. • Setting information in the IO-Link Device Configuration Settings is incorrect.	Connect the IO-Link device registered for the port of the IO-Link Master. Check the setting information in the IO-Link Device Configuration Settings.		
				• Error-level device event	Use CX-ConfiguratorFDT to confirm the IO-Link event code of the IO-Link device.	Refer to the manual for the IO-Link device and perform troubleshooting.		
Flashes at 2-s intervals.	Not lit	---	---	Initializing		---	This status does not indicate an error. Wait until the processing is completed.	
Flashes at 0.5-s intervals.	Not lit	---	---	• Automatic creation of the Unit configuration is in progress.		---	This status does not indicate an error. Wait until the processing is completed.	
Not lit	Not lit	Not lit	Not lit	Unit power supply error	There is insufficient or no Unit power supply.		Check the following items and make sure that power is correctly supplied from the Unit power supply. Make sure that the power supply cable is wired correctly. Make sure that there are no breaks in the power supply cable. Make sure that the power supply voltage is within the specified range. Make sure that the power supply has enough capacity. Make sure that the power supply has not failed. Make sure that the NX Units are connected correctly.	
				• Restarting is in progress for the Slave Terminal. • Waiting for initialization to start		---	This status does not indicate an error. Wait until the processing is completed.	
				Unit failure		---	Replace the Unit.	
Not lit	Lit	Not lit	Not lit	A hardware error or other critical error has occurred.	A hardware error has occurred.		Replace the Unit.	

TS		C		E		Unit status	Cause	Correction
Green	Red	Green	Red	Green	Red			
Not lit	Flashes at 1-s intervals.	Lit	Not lit	<ul style="list-style-type: none"> An error in communications with the Coupler Unit or other NX bus-related error that is common to all Units has occurred. The communications mode is IO-Link Mode. 				Refer to <i>NX Unit I/O Communications Error</i> on page 10-28.
		Not lit	Not lit	<ul style="list-style-type: none"> An error in communications with the Coupler Unit or other NX bus-related error that is common to all Units has occurred. IO-Link Mode is not used. 				

GX-type IO-Link Master Unit

● Power Status and IO-Link Communications-related Status

Unit PWR	IO PWR	C/E		Unit status	Cause	Correction	
		Green	Red				
Lit	Lit	Lit	Not lit	The Unit is operating normally. <ul style="list-style-type: none"> IO-Link communications are possible in IO-Link Mode. 	---	---	
		Not lit	Not lit	The Unit is operating normally. <ul style="list-style-type: none"> IO-Link communications are stopped in IO-Link Mode. IO-Link Mode is not used. 	---	---	
		Not lit	Lit	A hardware error or other critical error has occurred in the IO-Link port.	A hardware error has occurred.	Replace the Unit.	
		Not lit	Flashes at 0.5-s intervals.	One of the following occurred in IO-Link Mode.		---	---
				<ul style="list-style-type: none"> IO-Link communications error 	<ul style="list-style-type: none"> The I/O cable is broken. An IO-Link device has failed. IO-Link Master Unit failure 	Check the I/O cable to see if it is broken. If the cable is broken, replace it. Or, connect the IO-Link device to the port.	
			<ul style="list-style-type: none"> I/O cable short-circuit 	<ul style="list-style-type: none"> There is a short-circuit in the I/O cable. An IO-Link device has failed. 	There is a sensor power supply short-circuit on the input side, or a load short-circuit on the output side. Check the wiring.		
			<ul style="list-style-type: none"> Device configuration verification error 	<ul style="list-style-type: none"> The connected IO-Link device does not agree with the registered information. Setting information in the IO-Link Device Configuration Settings is incorrect. 	Connect the IO-Link device registered in the IO-Link Device Configuration Settings of the IO-Link Master Unit. Check the setting information of the IO-Link Device Configuration Settings.		
			<ul style="list-style-type: none"> Error-level device event 	Use CX-ConfiguratorFDT to confirm the IO-Link event code of the IO-Link device.	Refer to the manual for the IO-Link device and perform troubleshooting.		

Unit PWR	IO PWR	C/E		Unit status	Cause	Correction
		Green	Red			
Lit	Not lit	Not lit	Not lit	I/O power supply error	There is insufficient or no I/O power supply.	<p>Check the following items and correct the I/O power supply.</p> <p>Make sure that the power supply cable is wired correctly.</p> <p>Make sure that there are no breaks in the power supply cable.</p> <p>Make sure that the power supply voltage is within the specified range.</p> <p>Make sure that the power supply has enough capacity.</p> <p>Make sure that the power supply has not failed.</p>
Not lit	Not lit	Not lit	Not lit	Unit power supply error	There is insufficient or no Unit power supply.	<p>Check the following items and make sure that power is correctly supplied from the Unit power supply.</p> <p>Make sure that the power supply cable is wired correctly.</p> <p>Make sure that there are no breaks in the power supply cable.</p> <p>Make sure that the power supply voltage is within the specified range.</p> <p>Make sure that the power supply has enough capacity.</p> <p>Make sure that the power supply has not failed.</p>
				<ul style="list-style-type: none"> Restarting is in progress for the Slave Terminal. Waiting for initialization to start 	---	This status does not indicate an error. Wait until the processing is completed.
				Unit failure	A hardware error has occurred.	Replace the Unit.

● Common Errors for EtherCAT Slaves

B: Blinking, S: Single Flash, D: Double Flash, F: Flickering, -: Any status

Indicators		Error name	Meaning	Correction
RUN	ERR			
Not lit	Lit	Unit Processing Error	A fatal error was detected in the Unit.	Cycle the power supply. If the error still occurs, replace the Unit.
Not lit	Lit	ESC Error	An error occurred in the EtherCAT slave communications controller.	Replace the Unit.
Not lit	Lit	ESC Initialization Error	Initialization of the EtherCAT slave communications controller failed.	Replace the Unit.
Not lit	Lit	Slave Hardware Error	A hardware error occurred in the slave unit.	Replace the Unit.
Not lit	B	SII Device Configuration Verification Error	An device configuration verification error occurred in the SII.	Replace the Unit.
Not lit	B	Mailbox Setting Error	An incorrect mailbox setting was detected for the Sync Manager.	You can clear the error by resetting EtherCAT errors. To correct this error permanently, correct the mailbox setting in the EtherCAT Master Unit.

Indicators		Error name	Meaning	Correction
RUN	ERR			
B	B	RxPDO Setting Error	An error was detected in the RxPDO settings.	You can clear the error by resetting EtherCAT errors. To correct this error permanently, correct the RxPDO in the EtherCAT Master Unit.
B	B	TxPDO Setting Error	An error was detected in the TxPDO settings.	You can clear the error by resetting EtherCAT errors. To correct this error permanently, correct the TxPDO in the EtherCAT Master Unit.
B	B	PDO WDT Setting Error	An incorrect PDO WDT setting was detected.	You can clear the error by resetting EtherCAT errors. To correct this error permanently, correct the EtherCAT Master Unit settings.
B	B	Init State Transition Request	The slave requested a transition to the Init state.	You can clear the error by resetting EtherCAT errors.
B	B	SM Event Mode Setting Error	An SM Event Mode that is not supported was set.	You can clear the error by resetting EtherCAT errors. To correct this error permanently, correct the EtherCAT Master Unit settings.
B	B	TxPDO Mapping Error	An incorrect TxPDO was set.	You can clear the error by resetting EtherCAT errors. To correct this error permanently, correct the EtherCAT Master Unit settings.
B	B	RxPDO Mapping Error	An incorrect RxPDO was set.	You can clear the error by resetting EtherCAT errors. To correct this error permanently, correct the EtherCAT Master Unit settings.
-	B	Illegal State Transition Request Received	An incorrect state transition request was received.	You can clear the error by resetting EtherCAT errors. Review the EtherCAT Master Unit.
-	B	Error State Transition Received	An unclear state transition request was received.	You can clear the error by resetting EtherCAT errors. Review the EtherCAT Master Unit.
S	D	Process Data WDT Error	Process data communications were stopped for more than the specified period of time.	You can clear the error by resetting EtherCAT errors. <ul style="list-style-type: none"> • Check the EtherCAT Master Unit status and the communications cable, and eliminate the cause of the error. • Check the operation of the master and take appropriate measures if there is a problem.

The timing of flashing and flickering of the indicators is shown below.

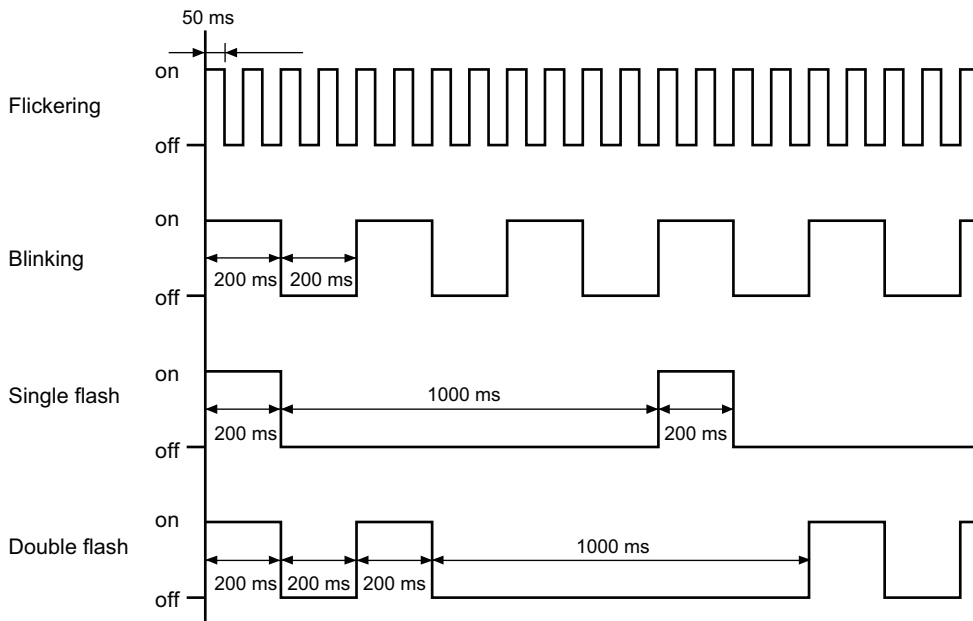

10-1-8 Assumed Causes and Corrections for Other Errors

Problem	Cause	Correction
Although a connected external device is ON, nothing is input and the input indicator is not lit either.	The I/O power is not supplied.	Check that the I/O power is supplied.
	The I/O power supply voltage is outside the rated range.	Set the I/O power supply voltage so that it is within the rated voltage range.
	The Unit is not wired correctly with the connected external device.	Check the wiring with the connected external device.
	The wiring to the connected external device is disconnected.	Check the wiring with the connected external device.
	A connected external device is defective.	Replace the connected external device.
A connected external device is ON and the input indicator is lit, but nothing is input.	A communications error occurred.	Check if an error has occurred between the controller and IO-Link Master Unit.
There is a delay in the ON and OFF timing for input values.	An input filter may be set.	Set the input filter value to 0. Alternatively, change the input filter to an appropriate value.

10-2 Checking for Errors and Troubleshooting with Tools

Error management on the IO-Link Master Unit is based on the methods used for the NJ/NX-series Controllers.

This allows you to use the IO-Link Master Unit Configuration Tool to check the meanings of errors and troubleshooting procedures.

The confirmation method depends on the IO-Link Master Unit Configuration Tool that is used.

10-2-1 Checking for Errors from the Sysmac Studio

When an error occurs, you can place the Sysmac Studio online with the Controller or the Communications Coupler Unit to check current errors and the log of past errors.

Refer to the user's manual for the connected Communications Coupler Unit for information on checking errors.

Current Errors

Open the Sysmac Studio's Controller Error Tab Page to check the current error's level, source, source details, event name, Sysmac event code, details, attached information 1 to 4, actions, and corrections. Observations are not displayed on this tab page.



Additional Information

Number of Current Errors

The following table gives the number of errors that are reported simultaneously as current errors in each Unit.

Unit	Number of simultaneous error notifications
NX-ILM400	15 errors
GX-ILM08C	32 errors

If the number of errors exceeds the maximum number of reportable current errors, errors are reported with a priority given to the oldest and highest-level errors. Errors that exceed the limit on simultaneous error notifications are not reported.

Errors that are not reported are still reflected in the error status.

Log of Past Errors

Open the Sysmac Studio's Controller Event Log Tab Page to check the times, levels, sources, source details, event names, Sysmac event codes, details, attached information 1 to 4, and corrections for previous errors.



Precautions for Correct Use

To check the event log for a GX-series IO-Link Master Unit, assign 512th transmit PDO *Mapping* (Sysmac Error Status) to I/O in advance in the PDO Map Settings on the Sysmac Studio.



Additional Information

Number of Events in Log of Past Errors

The following table gives the number of events that each event log can record. When the maximum number of records is exceeded and a new event occurs, the oldest data in the log is replaced with the new event information.

Event log category	Unit type	
	NX-type IO-Link Master Unit	GX-type IO-Link Master Unit
System event log	Total of 15 events	Total of 64 events
Access event log	Total of 2 events	---

Refer to the *NJ/NX-series Troubleshooting Manual* (Cat. No. W503), the *NY-series Troubleshooting Manual* (Cat. No. W564), and the *Sysmac Studio Version 1 Operation Manual* (Cat. No. W504) for the items that you can check and the procedures to check for errors.

Refer to *10-2-3 Sysmac Event Codes and Troubleshooting* on page 10-20 for details on Sysmac event codes.

10-2-2 Checking for Errors from Support Software Other Than the Sysmac Studio

You can check the error descriptions and logs with Support Software other than the Sysmac Studio.

For the error checking methods, refer to the user's manual for the connected Communications Coupler Unit and the operation manual for the Support Software.

Refer to *10-2-3 Sysmac Event Codes and Troubleshooting* on page 10-20 for details on event codes.

The number of current errors and the number of error log errors that occurred in the past are the same as for the Sysmac Studio.

10-2-3 Sysmac Event Codes and Troubleshooting

This section describes the errors (events) that can occur and how to troubleshoot them.

Error Tables

This section provides a table of the errors (events) that can occur in the IO-Link Master Unit.

Refer to *10-2-4 Reading Event Logs from a Tool* on page 10-46 for details on event logs.

The following abbreviations are used in the *Level* column.

Abbreviation	Name
Maj	Major fault level
Prt	Partial fault level
Min	Minor fault level
Obs	Observation
Info	Information
S	Event levels that are defined by the system.
U	Event levels that can be changed by the user.*1

*1. This symbol appears only for events for which the user can change the event level.

Refer to the *NJ/NX-series Troubleshooting Manual* (Cat. No. W503) for all NJ/NX-series Sysmac event codes.

Refer to the *NY-series Troubleshooting Manual* (Cat. No. W564) for all NY-series Industrial PC event codes.

● NX-type IO-Link Master Units

Sysmac event code	Event name	Meaning	Assumed cause	Level					Reference
				Maj	Prt	Min	Obs	Info	
00200000 hex	Non-volatile Memory Hardware Error	An error occurred in non-volatile memory.	Non-volatile memory failure			S			P. 10-25
10410000 hex	Control Parameter Error in Master	An error occurred in the control parameters that are saved in the master.	<p>For the NX bus of CPU Units</p> <p>The CPU Unit power was interrupted while the Unit operations settings were being written. Alternatively, there is an error in the area of the non-volatile memory in the CPU Unit in which the Unit operation settings for the NX Unit are saved.</p> <p>For Communications Coupler Units</p> <p>The Communications Coupler Unit power was interrupted while the Unit operations settings were being written. Alternatively, there is an error in the area of the non-volatile memory in the Communications Coupler Unit in which the Unit operation settings for the NX Unit are saved.</p>			S			P. 10-26

Sysmac event code	Event name	Meaning	Assumed cause	Level					Reference
				Maj	Prt	Min	Obs	Info	
40200000 hex	NX Unit Processing Error	A fatal error occurred in an NX Unit.	An error occurred in the software.			S			P. 10-27
80200000 hex	NX Unit I/O Communications Error	An I/O communications error occurred in an NX Unit.	<p>For the NX bus of CPU Units</p> <ul style="list-style-type: none"> An error occurred with which normal NX bus communications with the CPU Unit are not possible. The NX Unit is not mounted properly. The power cable for the Unit power supply is disconnected or the wiring from the Unit power supply to the NX Unit is incorrect. The power cable for the Unit power supply is broken. The voltage of the Unit power supply is outside the specified range. Or the capacity of the Unit power supply is insufficient. There is a hardware error in the NX Unit. <p>For Communications Coupler Units</p> <ul style="list-style-type: none"> An error occurred with which normal NX bus communications with the Communications Coupler Unit are not possible. The NX Unit is not mounted properly. The power cable for the Unit power supply is disconnected. Or, the wiring from the Unit power supply to the NX Units is incorrect. The power cable for the Unit power supply is broken. The voltage of the Unit power supply is outside the specified range. Or, the capacity of the Unit power supply is insufficient. There is a hardware error in the NX Unit. 			S			P. 10-28
80240000 hex	NX Unit Clock Not Synchronized Error	An error occurred in the clock information between the EtherCAT Coupler Unit and the NX Unit.	<p>For the NX bus of CPU Units</p> <ul style="list-style-type: none"> There is a hardware error in the NX Unit. There is a hardware error in the CPU Unit. <p>For Communications Coupler Units</p> <ul style="list-style-type: none"> There is a hardware error in the NX Unit. There is a hardware error in the EtherCAT Coupler Unit. 			S			P. 10-30
848F0000 hex	Device Configuration Verification Error	The connected device is different from the IO-Link device registered for a port of the IO-Link Master.	The connected device is different from the IO-Link device registered for a port of the IO-Link Master.			S			P. 10-31

Sysmac event code	Event name	Meaning	Assumed cause	Level					Reference
				Maj	Prt	Min	Obs	Info	
84970000 hex	I/O Cable Short-circuit	There is a short-circuit in the cable that connects the IO-Link master and device.	There is a short-circuit in the I/O cable. An IO-Link device has failed.			S			P. 10-31
849A0000 hex	IO-Link Communications Module Processing Error	A hardware failure occurred in the IO-Link Communications Module.	A hardware failure occurred.			S			P. 10-32
80220000 hex	NX Message Communications Error	An error was detected in message communications and the message frame was discarded.	For the NX bus of CPU Units • The message communications load is high. For Communications Coupler Units • The message communications load is high. • The communications cable is disconnected or broken. • Message communications were cutoff in communications.				S		P. 10-33
848C0000 hex	Error-level Device Event	An error-level event occurred in the IO-Link device.	Use CX-ConfiguratorFDT to confirm the IO-Link event code of the IO-Link device.				S		P. 10-34
848D0000 hex	IO-Link Communications Error	An error occurred in IO-Link communications with a device.	• The I/O cable is broken. Or, the IO-Link device is disconnected from the port. • An IO-Link device has failed. • The communications are affected by noise.				S		P. 10-35
84990000 hex	Information-level Device Event	An information-level event occurred in the IO-Link device.	Use CX-ConfiguratorFDT to confirm the IO-Link event code of the IO-Link device.				S		P. 10-35
84950000 hex	IO-Link Device Configuration Information Created	IO-Link device configuration information was created.	IO-Link device configuration information was created.					S	P. 10-36
84980000 hex	I/O Power Supply ON Detected	The I/O power supply ON was detected in several times.	The I/O power supply ON was detected in several times.					S	P. 10-36
90400000 hex	Event Log Cleared	The event log was cleared.	The event log was cleared by the user.					S	P. 10-37

● GX-type IO-Link Master Unit

Sysmac event code	Event name	Meaning	Assumed cause	Level					Reference
				Maj	Prt	Min	Obs	Info	
04A10000 hex	Non-volatile Memory Hardware Error	An error occurred in non-volatile memory.	Non-volatile memory failure			S			P. 10-38
04A20000 hex	Slave Hardware Error	A hardware error occurred in the slave unit.	The slave unit failed.			S			P. 10-38
14A00000 hex	Non-volatile Memory Checksum Error	An error occurred in the control parameters.	Noise			S			P. 10-39
847C0000 hex	Device Configuration Verification Error	The connected device is different from the IO-Link device registered for a port of the IO-Link Master.	The connected device is different from the IO-Link device registered for a port of the IO-Link Master.			S			P. 10-40
84840000 hex	I/O Cable Short-circuit	There is a short-circuit in the cable that connects the IO-Link master and device.	There is a short-circuit in the I/O cable. An IO-Link device has failed.			S			P. 10-41
84870000 hex	IO-Link Communications Module Processing Error	A hardware failure occurred in the IO-Link Communications Module.	A hardware failure occurred.			S			P. 10-42
84A00000 hex	Slave Unit Verification Error	An error occurred in Slave Unit verification.	An error occurred in the control board.			S			P. 10-42
84790000 hex	Error-level Device Event	An error-level event occurred in the IO-Link device.	Use CX-ConfiguratorFDT to confirm the IO-Link event code of the IO-Link device.			S			P. 10-43
847A0000 hex	IO-Link Communications Error	An error occurred in IO-Link communications with a device.	<ul style="list-style-type: none"> The I/O cable is broken. Or, the IO-Link device is disconnected from the port. An IO-Link device has failed. The communications are affected by noise. 			S			P. 10-44
84860000 hex	Information-level Device Event	An information-level event occurred in the IO-Link device.	Use CX-ConfiguratorFDT to confirm the IO-Link event code of the IO-Link device.				S		P. 10-45
84820000 hex	IO-Link Device Configuration Information Created	IO-Link device configuration information was created.	IO-Link device configuration information was created.					S	P. 10-45
84850000 hex	I/O Power Supply ON Detected	The I/O power supply ON was detected in several times.	The I/O power supply ON was detected in several times.					S	P. 10-46

Error Descriptions

This section describes the information that is given for individual errors.

● Controller Error Descriptions

The items that are used to describe individual errors (events) are described in the following copy of an error table.

Event name	Gives the name of the error.		Event code	Gives the code of the error.		
Meaning	Gives a short description of the error.					
Source	Gives the source of the error.		Source details	Gives details on the source of the error.	Detection timing	Tells when the error is detected.
Error attributes	Level	Tells the level of influence on control. ^{*1}			Log category	Tells which log the error is saved in. ^{*2}
	Recovery	Gives the recovery method. ^{*3}				
Effects	User program	Tells what will happen to execution of the user program. ^{*4}	Operation	Provides special information on the operation that results from the error.		
Indicators	Gives the status of the built-in EtherNet/IP port and built-in EtherCAT port indicators. Indicator status is given only for errors in the EtherCAT Master Function Module and the EtherNet/IP Function Module.					
System-defined variables	Variable	Data type		Name		
	Lists the variable names, data types, and meanings for system-defined variables that provide direct error notification, that are directly affected by the error, or that contain settings that cause the error.					
Cause and correction	Assumed cause		Correction		Prevention	
	Lists the possible causes, corrections, and preventive measures for the error.					
Attached information	This is the attached information that is displayed by the Support Software or an HMI. ^{*5 *6}					
Precautions/Remarks	Provides precautions, restrictions, and supplemental information. If the user can set the event level, the event levels that can be set, the recovery method, operational information, and other information is also provided.					

*1. One of the following:

Major fault: Major fault level
 Partial fault: Partial fault level
 Minor fault: Minor fault level
 Observation
 Information

*2. One of the following:

System: System event log
 Access: Access event log

*3. One of the following:

Automatic recovery: Normal status is restored automatically when the cause of the error is removed.
 Error reset: Normal status is restored when the error is reset after the cause of the error is removed.
 Cycle the power supply: Normal status is restored when the power supply to the Controller is turned OFF and then back ON after the cause of the error is removed.
 Controller reset: Normal status is restored when the Controller is reset after the cause of the error is removed.
 Depends on cause: The recovery method depends on the cause of the error.

*4. One of the following:

Continues: Execution of the user program will continue.
 Stops: Execution of the user program stops.
 Starts: Execution of the user program starts.

*5. "System information" indicates internal system information that is used by OMRON.

*6. Refer to the appendices of the *NJ/NX-series Troubleshooting Manual* (Cat. No. W503) for the applicable range of the HMI Troubleshooter.

● Error Descriptions

- NX-type IO-Link Master Units

Event name	Non-volatile Memory Hardware Error		Event code	00200000 hex	
Meaning	An error occurred in non-volatile memory.				
Source	Depends on where the Support Software is connected and the system configuration.	Source details	NX Unit	Detection timing	When power is turned ON to the NX Unit
Error attributes	Level	Minor fault		Log category	System
	Recovery	<p>For the NX bus of CPU Units Cycle the power supply to the Unit or restart the NX bus.</p> <p>For Communications Coupler Units Cycle the power supply to the Unit or restart the Slave Terminal. If the errors are detected in the Controller, reset all of the errors in the Controller.</p>			
Effects	User program	Continues.	Operation	Writing to non-volatile memory will not be possible.	
System-defined variables	Variable	Data type		Name	
	None	---		---	
Cause and correction	Assumed cause	Correction		Prevention	
	Non-volatile memory failure.	<p>For the NX bus of CPU Units Cycle the power supply to the Unit or restart the NX bus. If the error persists even after you make the above correction, replace the relevant NX Unit.5</p> <p>For Communications Coupler Units Cycle the power supply to the Unit or restart the Slave Terminal. If the error persists even after you make the above correction, replace the relevant NX Unit.</p>		None	
Attached information	None				
Precautions/Remarks	None				

Event name	Control Parameter Error in Master		Event code	10410000 hex	
Meaning	An error occurred in the control parameters that are saved in the master.				
Source	Depends on where the Support Software is connected and the system configuration.	Source details	NX Unit		Detection timing When power is turned ON to the NX Unit
Error attributes	Level	Minor fault		Log category	System
	Recovery	<p>For the NX bus of CPU Units</p> <p>Fail-soft Operation Setting Set to Stop Restart the NX Unit and then reset errors in the NX Bus Function Module.</p> <p>Fail-soft Operation Setting Set to Fail-soft Operation Restart the NX Unit and then reset errors in the NX Unit.</p> <p>For Communications Coupler Units</p> <p>Fail-soft Operation Setting Set to Stop If the errors are detected in the Controller, restart the NX Unit and then reset all of the errors in the Controller. If the errors are not detected in the Controller, restart the NX Unit and then reset the error in the Communications Coupler Unit.</p> <p>Fail-soft Operation Setting Set to Fail-soft Operation Restart the NX Unit and then reset errors in Communications Coupler Unit.</p>			
Effects	User program	Continues.	Operation	I/O refreshing for the NX Unit stops.	
System-defined variables	Variable	Data type		Name	
	None	---		---	
Cause and correction	Assumed cause		Correction		Prevention
	For the NX bus of CPU Units				
	The CPU Unit power was interrupted while the Unit operations settings were being written. Alternatively, there is an error in the area of the non-volatile memory in the CPU Unit in which the Unit operation settings for the NX Unit are saved.	Download the Unit operation settings of the NX Unit again. If the error occurs again even after you make the above correction, replace the CPU Unit.		Do not turn OFF the power supply to the CPU Unit while transfer of the Unit operation settings for the NX Unit or save of NX Unit parameters by a message is in progress.	
For Communications Coupler Units					
The Communications Coupler Unit power was interrupted while the Unit operations settings were being written. Alternatively, there is an error in the area of the non-volatile memory in the Communications Coupler Unit in which the Unit operation settings for the NX Unit are saved.	Download the Unit operation settings of the NX Unit again. If the error occurs again even after you make the above correction, replace the Communications Coupler Unit.		Do not turn OFF the power supply to the Communications Coupler Unit while transfer of the Unit operation settings for the NX Unit by a Support Software or save of NX Unit parameters by a message is in progress.		
Attached information	None				
Precautions/Remarks	None				

Event name	NX Unit Processing Error		Event code	40200000 hex	
Meaning	A fatal error occurred in an NX Unit.				
Source	Depends on where the Support Software is connected and the system configuration.	Source details	NX Unit	Detection timing	Continuously
Error attributes	Level	Minor fault		Log category	System
	Recovery	<p>For the NX bus of CPU Units Cycle the power supply to the NX Unit and then reset the error in the NX Bus Function Module.</p> <p>For Communications Coupler Units Cycle the power supply to the NX Unit and then reset the error in the Communications Coupler Unit.</p>			
Effects	User program	Continues.	Operation	I/O refreshing for the NX Unit stops. Messages cannot be sent to the NX Unit.	
System-defined variables	Variable	Data type		Name	
	None	---		---	
Cause and correction	Assumed cause	Correction		Prevention	
	An error occurred in the software.	<p>For the NX bus of CPU Units Cycle the power supply to the Unit, restart the NX Unit, or restart the NX bus. If this error occurs again even after the above correction, contact your OMRON representative.</p> <p>For Communications Coupler Units Cycle the power supply to the Unit, restart the NX Unit, or restart the Slave Terminal. If this error occurs again even after the above correction, contact your OMRON representative.</p>		None	
Attached information	<p>Attached information 1: System information</p> <p>Attached information 2: System information</p> <p>Attached information 3: System information</p> <p>Attached information 4: System information</p>				
Precautions/Remarks	None				

Event name	NX Unit I/O Communications Error		Event code	80200000 hex	
Meaning	An I/O Communications error occurred in the NX Unit.				
Source	Depends on where the Support Software is connected and the system configuration.	Source details	NX Unit	Detection timing	Continuously
Error attributes	Level	Minor fault		Log category	System
	Recovery	<p>For the NX bus of CPU Units</p> <p>Fail-soft Operation Setting Set to Stop Reset errors in the NX Bus Function Module.</p> <p>Fail-soft Operation Setting Set to Fail-soft Operation Reset error in the NX Unit.</p> <p>For Communications Coupler Units</p> <p>Fail-soft Operation Setting Set to Stop If the errors are detected in the Controller, reset all of the errors in the Controller.</p> <p>If the errors are not detected in the Controller, reset errors in the Communications Coupler Unit and NX Unit.</p> <p>Fail-soft Operation Setting Set to Fail-soft Operation Reset errors in Communications Coupler Unit and NX Unit..</p>			
Effects	User program	Continues.	Operation	The NX Unit will continue to operate. Input data: Updating input values stops. Output data: The output values depend on the Load Rejection Output Setting.	
System-defined variables	Variable	Data type		Name	
	None	---		---	

	Assumed cause	Correction	Prevention
Cause and correction	For the NX bus of CPU Units		
	An error occurred with which normal NX bus communications with the CPU Unit are not possible.	Check for errors in the CPU Unit and correct them if there are any.	Implement preventative measures for the error in the CPU Unit.
	The NX Unit is not mounted properly.	Mount the NX Units and End Cover securely and secure them with End Plates.	Mount the NX Units and End Cover securely and secure them with End Plates.
	The power cable for the Unit power supply is disconnected or the wiring from the Unit power supply to the NX Unit is incorrect.	Correctly wire the Unit power supply to the NX Units.	Correctly wire the Unit power supply to the NX Units.
	The power cable for the Unit power supply is broken.	If the power cable between the Unit power supply and the NX Units is broken, replace the cable.	None
	The voltage of the Unit power supply is outside the specified range. Or the capacity of the Unit power supply is insufficient.	Correctly configure the power supply system according to the power supply design methods.	Correctly configure the power supply system according to the power supply design methods.
	There is a hardware error in the NX Unit.	If the error occurs again even after you make the above correction, replace the NX Unit.	None
	For Communications Coupler Units		
	An error occurred with which normal NX bus communications with the Communications Coupler Unit are not possible.	Check for errors in the Communications Coupler Unit and correct them if there are any.	Implement preventative measures for the error in the Communications Coupler Unit.
	The NX Unit is not mounted properly.	Mount the NX Units and End Cover securely and secure them with End Plates.	Mount the NX Units and End Cover securely and secure them with End Plates.
	The power cable for the Unit power supply is disconnected. Or, the wiring from the Unit power supply to the NX Units is incorrect.	Correctly wire the Unit power supply to the NX Units.	Correctly wire the Unit power supply to the NX Units.
	The power cable for the Unit power supply is broken.	If the power cable between the Unit power supply and the NX Units is broken, replace the cable.	None
	The voltage of the Unit power supply is outside the specified range. Or, the capacity of the Unit power supply is insufficient.	Correctly configure the power supply system according to the power supply design methods.	Correctly configure the power supply system according to the power supply design methods.
	There is a hardware error in the NX Unit.	If the error occurs again even after you make the above correction, replace the NX Unit.	None
Attached information	None		
Precautions/Remarks	None		

Event name	NX Unit Clock Not Synchronized Error		Event code	80240000 hex	
Meaning	An error occurred in the NX Unit clock information.				
Source	Depends on where the Support Software is connected and the system configuration.	Source details	NX Unit	Detection timing	Continuously
Error attributes	Level	Minor fault		Log category	System
	Recovery	For the NX bus of CPU Units Cycle the power supply to the Unit . For Communications Coupler Units Cycle the power supply for the Unit and then reset all errors in Controller.			
Effects	User program	Continues.	Operation	The NX Unit will continue to operate. Input data: Updating input values stops. Output data: The output values depend on the Load Rejection Output Setting.	
System-defined variables	Variable	Data type		Name	
	None	---		---	
Cause and correction	Assumed cause	Correction		Prevention	
	For the NX bus of CPU Units				
	There is a hardware error in the NX Unit.	If the error occurred in only a specific NX Unit, replace that NX Unit.		None	
	There is a hardware error in the CPU Unit.	If the error occurred in all the NX Units mounted under the CPU Unit, replace the CPU Unit.		None	
	For Communications Coupler Units				
	There is a hardware error in the NX Unit.	If the error occurred in only a specific NX Unit, replace that NX Unit.		None	
There is a hardware error in the EtherCAT Coupler Unit.	If the error occurred in all the NX Units mounted under the Communications Coupler Unit, replace the Communications Coupler Unit.		None		
Attached information	None				
Precautions/Remarks	None				

Event name	Device Configuration Verification Error		Event code	848F 0000 hex	
Meaning	The connected device is different from the IO-Link device registered for a port of the IO-Link Master.				
Source	Depends on where the Support Software is connected and the system configuration.	Source details	NX Unit	Detection timing	When an IO-Link device is connected
Error attributes	Level	Minor fault			Log category
	Recovery	Reset error in the NX Unit.			
Effects	User program	Continues.	Operation	Operation will continue.	
				In the port with the error, cyclic communications with the IO-Link device are not correct.	
System-defined variables	Variable	Data type		Name	
	None	---		---	
Cause and correction	Assumed cause	Correction		Prevention	
	The connected device is different from the IO-Link device registered for a port of the IO-Link Master.	Connect the IO-Link device registered for the port of the IO-Link Master.		Connect the IO-Link device registered for the port of the IO-Link Master.	
Attached information	Attached information 1: Port where error occurred 0001 hex: Port 1 0002 hex: Port 2 0003 hex: Port 3 0004 hex: Port 4				
Precautions/Remarks	None				

Event name	I/O Cable Short-circuit		Event code	8497 0000 hex	
Meaning	There is a short-circuit in the cable that connects the IO-Link master and device.				
Source	Depends on where the Support Software is connected and the system configuration.	Source details	NX Unit	Detection timing	Continuously
Error attributes	Level	Minor fault			Log category
	Recovery	Reset error in the NX Unit.			
Effects	User program	Continues.	Operation	Operation will continue.	
				In the port with the error, cyclic communications with the IO-Link device are not correct.	
System-defined variables	Variable	Data type		Name	
	None	---		---	
Cause and correction	Assumed cause	Correction		Prevention	
	There is a short-circuit in the I/O cable.	Check to see if there is a short-circuit in the I/O cable. If there is a short-circuit, replace the cable.		None	
	An IO-Link device has failed.	Replace the IO-Link device.		None	
Attached information	Attached information 1: Port where error occurred 0001 hex: Port 1 0002 hex: Port 2 0003 hex: Port 3 0004 hex: Port 4				
Precautions/Remarks	None				

Event name	IO-Link Communications Module Processing Error		Event code	849A0000 hex		
Meaning	A hardware failure occurred in the IO-Link Communications Module.					
Source	Depends on where the Support Software is connected and the system configuration.	Source details	NX Unit	Detection timing	Continuously	
Error attributes	Level	Minor fault			Log category	System
	Recovery	Cycle the power supply to the NX Unit.				
Effects	User program	Continues.	Operation	Operation will continue. It is possible that the data received from the IO-Link device is not correct.		
	System-defined variables	Variable	Data type	Name		
	None	---	---			
Cause and correction	Assumed cause	Correction	Prevention			
	A hardware failure occurred.	If cycling the power supply to the Unit does not clear the error, replace the NX Unit.	None			
Attached information	None					
Precautions/Remarks	None					

Event name	NX Message Communications Error		Event code	80220000 hex	
Meaning	An error was detected in message communications and the message frame was discarded.				
Source	Depends on where the Support Software is connected and the system configuration.	Source details	NX Unit		Detection timing During NX message communications
Error attributes	Level	Observation			Log category
	Recovery	---			
Effects	User program	Continues.	Operation	Not affected.	
System-defined variables	Variable	Data type		Name	
	None	---		---	
Cause and correction	Assumed cause		Correction		Prevention
	For the NX bus of CPU Units				
	The message communications load is high.		Reduce the number of times that instructions are used to send NX messages.		Reduce the number of times that instructions are used to send NX messages.
	For Communications Coupler Units				
	The message communications load is high.		Reduce the number of times that instructions are used to send NX messages.		Reduce the number of times that instructions are used to send NX messages.
	The communications cable is disconnected or broken. This cause does not apply if attached information 2 is 0 (NX bus).		Connect the communications cable securely.		Connect the communications cable securely.
Message communications were cutoff by executing the followings in message communications. <ul style="list-style-type: none"> • Transfer of parameters by the Support Software • Restoration of the backup data (if this error occurred in the EtherCAT Slave Terminal) • Disconnection of an EtherCAT slave (if this error occurred in the EtherCAT Slave Terminal) 		---		---	
Attached information	Attached information 1: System information				
	Attached information 2: Type of communications where error occurred 0: NX bus 1: EtherCAT 2: Serial communications (USB) 3: EtherNet/IP 65535: Internal Unit communications (routing)				
Precautions/Remarks	None				

Event name	Error-level Device Event		Event code	848C0000 hex	
Meaning	An error-level event occurred in the IO-Link device.				
Source	Depends on where the Support Software is connected and the system configuration.	Source details	NX Unit	Detection timing	Continuously
Error attributes	Level	Observation		Log category	System
	Recovery	Reset error. If the error cannot be recovered, restart the NX Unit because the error is continued in the IO-Link device.			
Effects	User program	Continues.	Operation	Operation will continue.	
				It is possible that the data received from the IO-Link device is not correct.	
System-defined variables	Variable	Data type		Name	
	None	---		---	
Cause and correction	Assumed cause	Correction		Prevention	
	Use CX-Configurator FDT to confirm the IO-Link event code of the IO-Link device.	Check the correction from the IO-Link event code of the IO-Link device.		Check the prevention measures from the IO-Link event code of the IO-Link device.	
Attached information	Attached information 1: Port where error occurred 0001 hex: Port 1 0002 hex: Port 2 0003 hex: Port 3 0004 hex: Port 4				
Precautions/Remarks	None				

Event name	IO-Link Communications Error		Event code	848D0000 hex		
Meaning	An error occurred in IO-Link communications with a device.					
Source	Depends on where the Support Software is connected and the system configuration.	Source details	NX Unit	Detection timing	Continuously	
Error attributes	Level	Observation			Log category	System
	Recovery	Reset error				
Effects	User program	Continues.	Operation	Operation will continue. It is possible that the data received from the IO-Link device is not correct.		
System-defined variables	Variable	Data type		Name		
	None	---		---		
Cause and correction	Assumed cause	Correction		Prevention		
	The I/O cable is broken. Or, the IO-Link device is disconnected from the port.	Check the I/O cable to see if it is broken. If the cable is broken, replace it. Or, connect the IO-Link device to the port.		None		
	An IO-Link device has failed.	Replace the IO-Link device.		None		
	The communications are affected by noise.	Implement noise countermeasures.		Implement noise countermeasures.		
Attached information	Attached information 1: Port where error occurred 0001 hex: Port 1 0002 hex: Port 2 0003 hex: Port 3 0004 hex: Port 4					
Precautions/Remarks	None					

Event name	Warning-level Device Event Flag		Event code	84990000 hex		
Meaning	A warning-level event occurred in the IO-Link device.					
Source	Depends on where the Support Software is connected and the system configuration.	Source details	NX Unit	Detection timing	Continuously	
Error attributes	Level	Observation			Log category	System
	Recovery	Reset error. If the error cannot be recovered, restart the NX Unit because the error is continued in the IO-Link device.				
Effects	User program	Continues.	Operation	Operation will continue. It is possible that the data received from the IO-Link device is not correct.		
System-defined variables	Variable	Data type		Name		
	None	---		---		
Cause and correction	Assumed cause	Correction		Prevention		
	Use CX-ConfiguratorFDT to confirm the IO-Link event code of the IO-Link device.	Check the correction from the IO-Link event code of the IO-Link device.		Check the prevention measures from the IO-Link event code of the IO-Link device.		
Attached information	Attached information 1: Port where error occurred 0001 hex: Port 1 0002 hex: Port 2 0003 hex: Port 3 0004 hex: Port 4					
Precautions/Remarks	None					

Event name	IO-Link Device Configuration Information Created		Event code	84950000 hex	
Meaning	IO-Link device configuration information was created.				
Source	Depends on where the Support Software is connected and the system configuration.	Source details	NX Unit	Detection timing	Continuously
Error attributes	Level	Information			Log category
	Recovery	---			
Effects	User program	Continues.	Operation	Not affected.	
System-defined variables	Variable	Data type		Name	
	None	---		---	
Cause and correction	Assumed cause	Correction		Prevention	
	IO-Link device configuration information was created.	---		---	
Attached information	None				
Precautions/Remarks	None				

Event name	I/O power supply ON detected (for NX-type)		Event code	84980000 hex	
Meaning	The I/O power supply ON was detected in several times.				
Source	Depends on where the Support Software is connected and the system configuration.	Source details	NX Unit	Detection timing	Continuously
Error attributes	Level	Information			Log category
	Recovery	---			
Effects	User program	Continues.	Operation	Not affected.	
System-defined variables	Variable	Data type		Name	
	None	---		---	
Cause and correction	Assumed cause	Correction		Prevention	
	The I/O power supply ON was detected in several times. The I/O power supply may be unstable.	---		---	
Attached information	None				
Precautions/Remarks	None				

Event name	Event Log Cleared		Event code	90400000 hex	
Meaning	The event log was cleared.				
Source	Depends on where the Support Software is connected and the system configuration.	Source details	NX Unit		Detection timing When commanded from user
Error attributes	Level	Information			Log category
	Recovery	---			
Effects	User program	Continues.	Operation	Not affected.	
System-defined variables	Variable	Data type		Name	
	None	---		---	
Cause and correction	Assumed cause	Correction		Prevention	
	The event log was cleared by the user.	---		---	
Attached information	Attached information: Events that were cleared 1: The system event log was cleared. 2: The access event log was cleared.				
Precautions/Remarks	None				

- GX-type IO-Link Master Units

Event name	Non-volatile Memory Hardware Error		Event code	04A10000 hex	
Meaning	An error occurred in non-volatile memory.				
Source	EtherCAT Master Function Module	Source details	Slave	Detection timing	When establishing communications after turning ON power to the Slave Unit
Error attributes	Level	Minor fault		Log category	System
	Recovery	---			
Effects	User program	Continues	Operation	Writing to non-volatile memory is not possible.	
Indicators	EtherCAT NET RUN		EtherCAT NET ERR		EtherCAT LINK/ACT
	---		---		---
System-defined variables	Variable		Data type		Name
	None		---		---
Cause and correction	Assumed cause		Correction		Prevention
	Non-volatile memory failure.		Replace the EtherCAT Slave Unit.		None
Attached information	None				
Precautions/Remarks	The emergency error code is 5530 hex.				

Event name	Slave Hardware Error		Event code	04A20000 hex	
Meaning	A hardware error occurred in the EtherCAT communications section.				
Source	EtherCAT Master Function Module	Source details	Slave	Detection timing	Continuously
Error attributes	Level	Minor fault		Log category	System
	Recovery	Error reset (after cycling Slave Unit power)			
Effects	User program	Continues	Operation	The Slave Unit where the error occurred performs the error output operation (fail-safe).	
Indicators	EtherCAT NET RUN		EtherCAT NET ERR		EtherCAT LINK/ACT
	---		---		---
System-defined variables	Variable		Data type		Name
	None		---		---
Cause and correction	Assumed cause		Correction		Prevention
	The Slave Unit is faulty.		If cycling the power supply does not correct the problem, replace the Slave Unit.		None
Attached information	None				
Precautions/Remarks	The emergency error codes are 7030 hex and 7100 hex.				

Event name	Non-volatile Memory Checksum Error		Event code	14A0 0000 hex	
Meaning	An error occurred in the control parameters.				
Source	EtherCAT Master Function Module	Source details	Slave	Detection timing	When establishing communications after turning ON power to the Slave Unit
Error attributes	Level	Minor fault		Log category	System
	Recovery	Error reset (after cycling Slave Unit power)			
Effects	User program	Continues	Operation	The Slave Unit's I/O communications stop and the outputs turn OFF.	
Indicators	EtherCAT NET RUN		EtherCAT NET ERR		EtherCAT LINK/ACT
	---		Flashes at 1-s intervals.		---
System-defined variables	Variable	Data type		Name	
	None	---		---	
Cause and correction	Assumed cause		Correction		Prevention
	Noise		Return the control parameters to their default settings using restore parameters (1011 hex) of the EtherCAT Slave Unit.		Implement noise countermeasures.
Attached information	None				
Precautions/Remarks	The emergency error code is 6330 hex.				

Event name	Device Configuration Verification Error		Event code	847C0000 hex	
Meaning	The connected device is different from the IO-Link device registered for a port of the IO-Link Master.				
Source	EtherCAT Master Function Module	Source details	Slave	Detection timing	When an IO-Link device is connected
Error attributes	Level	Minor fault		Log category	System
	Recovery	Reset error			
Effects	User program	Continues.	Operation	Operation will continue.	
				In the port with the error, cyclic communications with the IO-Link device are not correct.	
System-defined variables	Variable	Data type		Name	
	None	---		---	
Cause and correction	Assumed cause	Correction		Prevention	
	The connected device is different from the IO-Link device registered for a port of the IO-Link Master.	Connect the IO-Link device registered for the port of the IO-Link Master.		Connect the IO-Link device registered for the port of the IO-Link Master.	
Attached information	Attached information 1: Port where error occurred 1 hex: Port 1 2 hex: Port 2 3 hex: Port 3 4 hex: Port 4 5 hex: Port 5 6 hex: Port 6 7 hex: Port 7 8 hex: Port 8				
Precautions/Remarks	None				

Event name	I/O Cable Short-circuit		Event code	8484 0000 hex		
Meaning	There is a short-circuit in the cable that connects the IO-Link master and device.					
Source	EtherCAT Master Function Module	Source details	Slave	Detection timing	Continuously	
Error attributes	Level	Minor fault			Log category	System
	Recovery	Reset error				
Effects	User program	Continues.	Operation	Operation will continue. In the port with the error, cyclic communications with the IO-Link device are not correct.		
System-defined variables	Variable	Data type		Name		
	None	---		---		
Cause and correction	Assumed cause		Correction		Prevention	
	There is a short-circuit in the I/O cable.		Check to see if there is a short-circuit in the I/O cable. If there is a short-circuit, replace the cable.		None	
	An IO-Link device has failed.		Replace the IO-Link device.		None	
Attached information	Attached information 1: Port where error occurred 1 hex: Port 1 2 hex: Port 2 3 hex: Port 3 4 hex: Port 4 5 hex: Port 5 6 hex: Port 6 7 hex: Port 7 8 hex: Port 8					
Precautions/Remarks	None					

Event name	IO-Link Communications Module Processing Error		Event code	84870000 hex		
Meaning	A hardware failure occurred in the IO-Link Communications Module.					
Source	EtherCAT Master Function Module	Source details	Slave	Detection timing	Continuously	
Error attributes	Level	Minor fault			Log category	System
	Recovery	Cycle the power supply to the slave.				
Effects	User program	Continues.	Operation	Operation will continue. It is possible that the data received from the IO-Link device is not correct.		
	System-defined variables	Variable	Data type	Name		
	None	---	---			
Cause and correction	Assumed cause	Correction	Prevention			
	A hardware failure occurred.	If cycling the power supply to the slave does not clear the error, replace the slave.	None			
Attached information	None					
Precautions/Remarks	None					

Event name	Slave Unit Verification Error		Event code	84A00000 hex		
Meaning	An SII verification error occurred. An SII verification error occurred.					
Source	EtherCAT Master Function Module	Source details	Slave	Detection timing	When establishing communications after turning ON power to the slave	
Error attributes	Level	Minor fault			Log category	System
	Recovery	Error reset (after cycling slave power)				
Effects	User program	Continues.	Operation	A slave with an error cannot enter Pre-operational state.		
	System-defined variables	Variable	Data type	Name		
	None	---	---			
Cause and correction	Assumed cause	Correction	Prevention			
	An error occurred in the control board.	Cycle the power supply. If the error occurs again, replace the Unit.	None			
Attached information	None					
Precautions/Remarks	The emergency error code is 6140 hex.					

Event name	Error-level Device Event		Event code	84790000 hex	
Meaning	An error-level event occurred in the IO-Link device.				
Source	EtherCAT Master Function Module	Source details	Slave	Detection timing	Continuously
Error attributes	Level	Observation		Log category	System
	Recovery	Reset error. If the error cannot be recovered, cycle the power supply to the slave because the error is continued in the IO-Link device.			
Effects	User program	Continues.	Operation	Operation will continue.	
				It is possible that the data received from the IO-Link device is not correct.	
System-defined variables	Variable	Data type		Name	
	None	---		---	
Cause and correction	Assumed cause	Correction		Prevention	
	Use CX-ConfiguratorFDT to confirm the IO-Link event code of the IO-Link device.	Check the correction from the IO-Link event code of the IO-Link device.		Check the prevention measures from the IO-Link event code of the IO-Link device.	
Attached information	Attached information 1: Port where error occurred 1 hex: Port 1 2 hex: Port 2 3 hex: Port 3 4 hex: Port 4 5 hex: Port 5 6 hex: Port 6 7 hex: Port 7 8 hex: Port 8				
Precautions/Remarks	None				

Event name	IO-Link Communications Error		Event code	847A0000 hex		
Meaning	An error occurred in IO-Link communications with a device.					
Source	EtherCAT Master Function Module	Source details	Slave	Detection timing	Continuously	
Error attributes	Level	Observation			Log category	System
	Recovery	Reset error				
Effects	User program	Continues.	Operation	Operation will continue.		
				It is possible that the data received from the IO-Link device is not correct.		
System-defined variables	Variable	Data type		Name		
	None	---		---		
Cause and correction	Assumed cause	Correction		Prevention		
	The I/O cable is broken. Or, the IO-Link device is disconnected from the port.	Check the I/O cable to see if it is broken. If the cable is broken, replace it. Or, connect the IO-Link device to the port.		None		
	An IO-Link device has failed.	Replace the IO-Link device.		None		
	The communications are affected by noise.	Implement noise countermeasures.		Implement noise countermeasures.		
Attached information	Attached information 1: Port where error occurred 1 hex: Port 1 2 hex: Port 2 3 hex: Port 3 4 hex: Port 4 5 hex: Port 5 6 hex: Port 6 7 hex: Port 7 8 hex: Port 8					
Precautions/Remarks	None					

Event name	Warning-level Device Event Flag		Event code	84860000 hex	
Meaning	A warning-level event occurred in the IO-Link device.				
Source	EtherCAT Master Function Module	Source details	Slave	Detection timing	Continuously
Error attributes	Level	Observation		Log category	System
	Recovery	Reset error. If the error cannot be recovered, cycle the power supply to the slave because the error is continued in the IO-Link device.			
Effects	User program	Continues.	Operation	Operation will continue.	
				It is possible that the data received from the IO-Link device is not correct.	
System-defined variables	Variable	Data type		Name	
	None	---		---	
Cause and correction	Assumed cause	Correction		Prevention	
	Use CX-ConfiguratorFDT to confirm the IO-Link event code of the IO-Link device.	Check the correction from the IO-Link event code of the IO-Link device.		Check the prevention measures from the IO-Link event code of the IO-Link device.	
Attached information	Attached information 1: Port where error occurred 1 hex: Port 1 2 hex: Port 2 3 hex: Port 3 4 hex: Port 4 5 hex: Port 5 6 hex: Port 6 7 hex: Port 7 8 hex: Port 8				
Precautions/Remarks	None				

Event name	IO-Link Device Configuration Information Created		Event code	84820000 hex	
Meaning	IO-Link device configuration information was created.				
Source	EtherCAT Master Function Module	Source details	Slave	Detection timing	Continuously
Error attributes	Level	Information		Log category	System
	Recovery	---			
Effects	User program	Continues.	Operation	Not affected.	
System-defined variables	Variable	Data type		Name	
	None	---		---	
Cause and correction	Assumed cause	Correction		Prevention	
	IO-Link device configuration information was created.	---		---	
Attached information	None				
Precautions/Remarks	None				

Event name	I/O Power Supply ON Detected		Event code	84850000 hex	
Meaning	The I/O power supply ON was detected in several times.				
Source	EtherCAT Master Function Module	Source details	Slave	Detection timing	Continuously
Error attributes	Level	Information			Log category
	Recovery	---			
Effects	User program	Continues.	Operation	Not affected.	
System-defined variables	Variable	Data type		Name	
	None	---		---	
Cause and correction	Assumed cause	Correction		Prevention	
	The I/O power supply ON was detected in several times. The I/O power supply may be unstable.	---		---	
Attached information	None				
Precautions/Remarks	None				

10-2-4 Reading Event Logs from a Tool

The event logs of the IO-Link Master Unit can be read with the IO-Link Master Unit Configuration Tool. This section describes how to read the event logs with Sysmac Studio. For how to read the event logs with an IO-Link Master Unit Configuration Tool other than Sysmac Studio, refer to the operation manual for the IO-Link Master Unit Configuration Tool that you are using.

Use the following procedure to read the event logs.

- 1** Select **Troubleshooting** from the Tools Menu while online. You can also click the **Troubleshooting** Button in the toolbar.
The Event Log Troubleshooting Dialog Box is displayed.
- 2** Click the **Controller Event Log** Tab.
The following event log is displayed.
Click the **Update** Button to display the latest event log.
If an event is for a Slave Terminal, the node number of the Slave Terminal and the NX Unit number are displayed as the source details.



Additional Information

- If the most recent version of the Sysmac Studio is not used, the Sysmac Studio may not support some events. If unsupported events occur, *Unknown* is given for the source and *Unknown Event* is given for the event name. The Sysmac event code and attached information are displayed correctly.

Use the most recent version of the Sysmac Studio to check events.

- Refer to the appendices of the *NJ/NX-series Troubleshooting Manual* (Cat. No. W503) or the *NY-series Troubleshooting Manual* (Cat. No. W564) for the specifications for checking EtherCAT Slave Terminal errors on an OMRON HMI.

10-2-5 Clearing Event Logs from a Tool

The event logs of the IO-Link Master Unit can be cleared with the IO-Link Master Unit Configuration Tool.

This section describes how to clear the event logs with Sysmac Studio.

For how to clear the event logs with an IO-Link Master Unit Configuration Tool other than Sysmac Studio, refer to the operation manual for the IO-Link Master Unit Configuration Tool that you are using.

Use the following procedures to specify the event logs to clear and clear those event logs.

● Specifying the Event Logs to Clear

When you clear the event log, you can specify what parts to clear.

Sysmac Studio connection	Unit to clear log from		
	NX-type IO-Link Master Unit		GX-type IO-Link Master Unit
	Specifying to clear all of the events from the Slave Terminal	Specifying individual events to clear	
Peripheral USB port or built-in EtherNet/IP port on NJ/NX-series CPU Unit	Entire EtherCAT Slave Terminal	NX-type IO-Link Master Unit	GX-type IO-Link Master Unit
Peripheral USB port on EtherCAT Coupler Unit			Cannot be connected.

● Procedure for Clearing Event Logs

From the Controller Event Log Tab Page, you can clear the event logs for an entire Slave Terminal or the event logs for a specified IO-Link Master Unit.

- 1** Select **Troubleshooting** from the Tools Menu while online. You can also click the **Troubleshooting** Button in the toolbar.
The Event Log Troubleshooting Dialog Box is displayed.
- 2** In the Select the Display Target Area of the Controller Event Log Tab Page, select the Units to clear and click the **Clear** Button.
A confirmation dialog box is displayed.
- 3** Click the **Yes** Button.
The selected event logs are cleared.

10-2-6 Exporting Event Logs from a Tool

The contents of the event logs can be exported as a CSV file using the IO-Link Master Unit Configuration Tool.

This section describes how to export the contents of the event logs with Sysmac Studio.

For how to export the contents of the event logs with the IO-Link Master Unit Configuration Tool other than Sysmac Studio, refer to the operation manual for the IO-Link Master Unit Configuration Tool that you are using.

Use the following procedure to export the event logs.

- 1** Select **Troubleshooting** from the Tools Menu while online. You can also click the **Troubleshooting** Button in the toolbar.
The Event Log Troubleshooting Dialog Box is displayed.
- 2** In the Select the Display Target Area of the Controller Event Log Tab Page, select the Unit for which to export the events and click the **Save** Button.
The Save Dialog Box is displayed.
- 3** Enter the file name and click the **Save** Button.
The Controller event logs are saved in CSV format.

10-3 Backing Up Settings and Replacing Units

This section describes the backup and restoration of parameter settings in IO-Link devices and the replacement of Units.

The controller backup and restoration functions that are described in this section cannot be used for the backup and restoration of the IO-Link Master Unit connected to the EtherNet/IP Slave Terminal.

Download the parameters saved with the IO-Link Master Unit Configuration Tool to the replacement IO-Link Master Unit.

10-3-1 Backup and Restore Methods

Backup and restoration of parameter settings in the IO-Link Master Unit and backup and restoration of parameter settings in the IO-Link devices are described below.

Backing Up and Restoring Parameter Settings in IO-Link Master Units

To back up, restore, and verify IO-Link Master Unit parameter settings, use the backup functions for the entire NJ/NX-series Controller or NY-series Industrial PC. The functions also backup all the other data in the Controller.

You can use the backup functions of the Sysmac Studio to back up, restore, and verify settings to an SD Memory Card^{*1} inserted in the CPU Unit or a specified memory device on the computer.

*1. For an NY-series Industrial PC, this is a Virtual SD Memory Card. For details on a virtual SD Memory Card for an NY-series Industrial PC, refer to the *NY-series IPC Machine Controller Industrial Panel PC / Industrial Box PC Software User's Manual* (Cat. No. W558).

● SD Memory Card Backup Functions

You can back up, restore, and compare the entire controller to the data in an SD Memory Card.

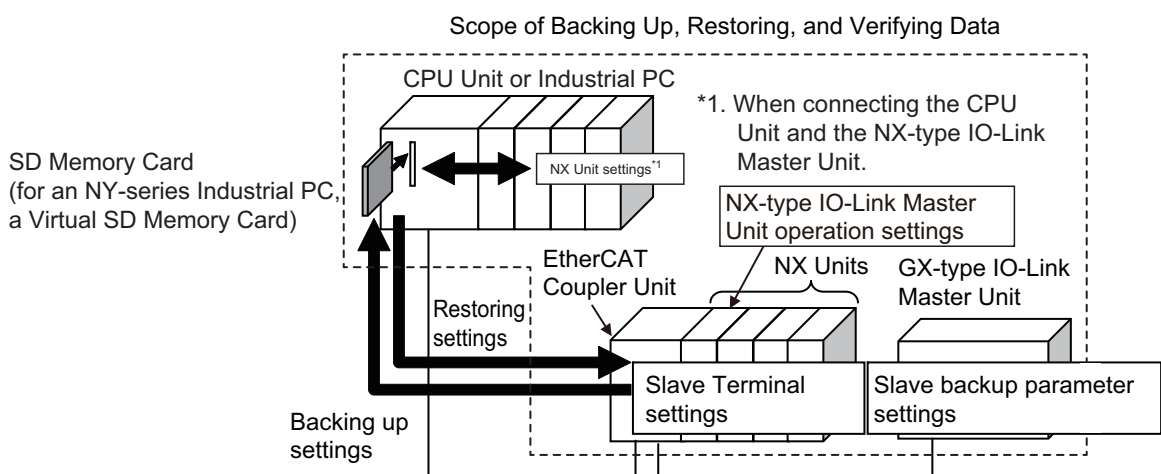

● **Sysmac Studio Controller Backup Functions**

You can use the Sysmac Studio to execute the backup, restore, and verify the entire data in the Controller with which the Sysmac Studio is online.

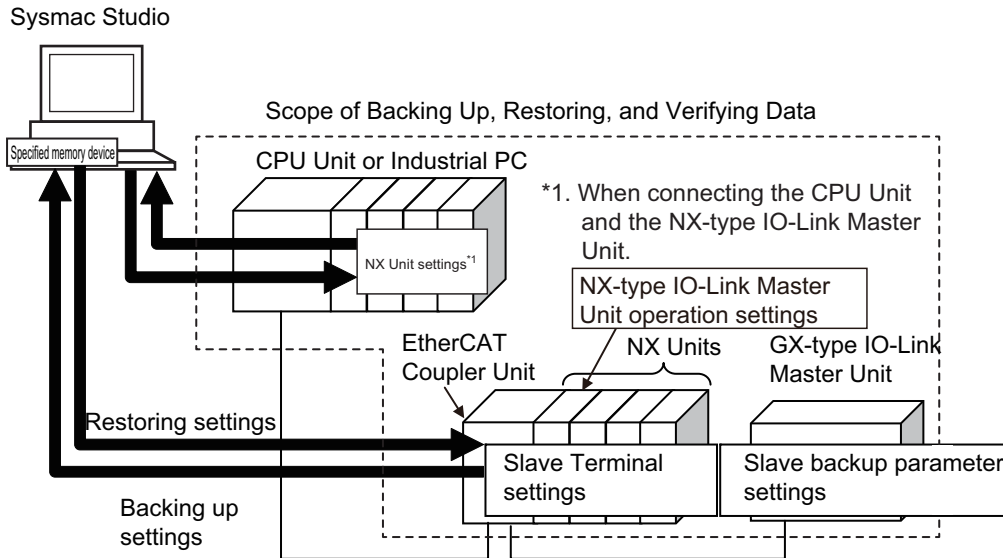

The range of data that is backed up is different for GX-type IO-Link Master Units and NX-type IO-Link Master Units, as described below.

● **GX-type IO-Link Master Units**

The parameter settings of the GX-type IO-Link Master Unit are backed up, restored, or verified as parameters of the EtherCAT Slave Terminal.

● **NX-type IO-Link Master Units**

The Unit operation settings of the NX-type IO-Link Master Unit are backed up, restored, or verified as the settings for the entire Slave Terminal that consists of the Communications Coupler Unit and the NX Units (including the NX-type IO-Link Master Unit).

Refer to the software user's manual of the connected CPU Unit for details on the backup functions.

Backing Up and Restoring Parameter Settings in IO-Link Devices

You can backup the parameter settings of the IO-Link devices to the connected IO-Link Master Unit.

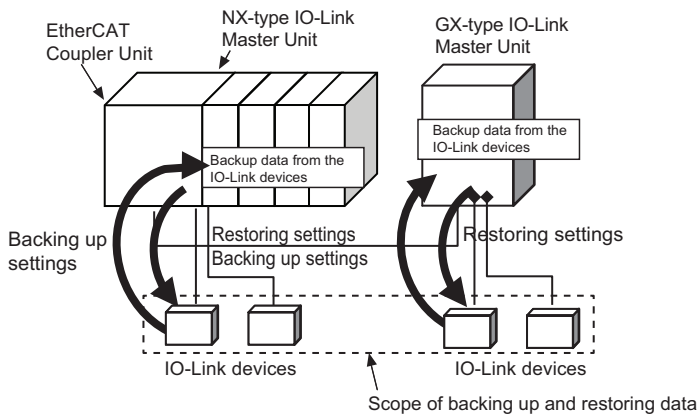

For information on backup and restoration of the parameter settings in the IO-Link devices, refer to 7-6 *Backup and Restoration of Parameter Settings in IO-Link Devices* on page 7-14.

**Precautions for Correct Use**

The parameter settings of the IO-Link devices are not backed up, restored, or verified when the parameter settings of the IO-Link Master Unit are backed up, restored, or Verified to an SD Memory Card*¹ or the Sysmac Studio.

*1. For an NY-series Industrial PC, this is a Virtual SD Memory Card.

10-3-2 Replacing the IO-Link Master Unit or IO-Link Devices

The method of replacing the IO-Link Master Unit or the IO-Link devices is described below.

Replacement Method for IO-Link Master Units

Use the following procedure to replace an IO-Link Master Unit.

- 1** Use the Sysmac Studio to back up the parameter settings in the IO-Link Master Unit to an SD Memory Card*¹ inserted in the CPU Unit or to a specified memory device on the computer.
*1. For an NY-series Industrial PC, this is a Virtual SD Memory Card.
- 2** Turn OFF the Unit power supply and I/O power supply to the IO-Link Master Unit.
- 3** Replace the IO-Link Master Unit.
Refer to the Basic Replacement Procedure for NX Units for you Communications Coupler Unit for the replacement procedure for NX Units.
- 4** Turn ON the Unit power supply and I/O power supply to the IO-Link Master Unit.

**Precautions for Correct Use**

If you replace the IO-Link Master Unit with an IO-Link Master Unit to which IO-Link device backup data was previously written, clear the IO-Link backup data before you connect the devices.

If backup data for the IO-Link devices is not cleared, parameter settings will be restored for the following conditions.

- Device verification is enabled for the port and the parameter settings match.
- Restoring parameter settings is enabled in the Restoration Setting for the port.

For information on how to clear backup data, refer to *Backup and Restoration of Parameter Settings in IO-Link Devices* on page 7-14.

- 5** Restore the backed up IO-Link Master Unit parameter settings to the IO-Link Master Unit.
- 6** Back up the parameter settings of the IO-Link devices.
For details on backup and restoration for IO-Link settings, refer to *Automatic Backup when IO-Link communications start* on page 7-16 of *7-6 Backup and Restoration of Parameter Settings in IO-Link Devices* on page 7-14.

Replacement Method for IO-Link Devices

● Procedure for Backing Up the Parameters from the IO-Link Devices to the IO-Link Master Unit

First, use the backup functions of the IO-Link device parameter settings to back up the parameters from the IO-Link devices to the IO-Link Master Unit. The procedure is given below.

- 1** Use the IO-Link Master Unit Configuration Tool to enable backup with the Backup Settings of the ports in the IO-Link Master Unit that is connected to the IO-Link devices for which parameters are to be backed up.
Disable restoration with the Restoration Setting.
- 2** Set the parameters in the IO-Link devices. Use the CX-ConfiguratorFDT or hardware on the IO-Link devices to make the settings.
- 3** Adjust the devices, and change the parameter settings of the IO-Link devices.
- 4** Use the start of IO-Link communications or communications instructions to the IO-Link devices to backup the parameters of the IO-Link devices in the IO-Link Master Unit.
- 5** Use the IO-Link Master Unit Configuration Tool to enable backup and enable restoration of the parameters in the IO-Link Master Unit.
- 6** Operate the devices.

● Procedure to Replace IO-Link Devices and Restore Parameter Settings

Next, after you use the following procedure to replace the IO-Link devices, restore the parameter settings to the IO-Link devices that were backed up in the IO-Link Master Unit.

- 1** Turn OFF the I/O power supply to the IO-Link Master Unit.
- 2** Replace IO-Link devices when they fail.
- 3** Turn ON the I/O power supply to the IO-Link Master Unit.
- 4** IO-Link communications are started. The restoration operation is executed automatically.

For details on backup and restoration for IO-Link devices, refer to *7-6 Backup and Restoration of Parameter Settings in IO-Link Devices* on page 7-14



Precautions for Correct Use

When you replace an IO-Link device, confirm that the model of the IO-Link device is correct, confirm that the terminal block mounting position is correct, set the replacement IO-Link device suitably, and confirm that the IO-Link device operates correctly.

10-3-3 Replacing the IO-Link Master Unit and IO-Link Devices at the Same Time

Use the following procedures to replace the IO-Link Master Unit and IO-Link devices at the same time.

Backing Up Parameter Settings

- 1** Use the Sysmac Studio to back up the parameter settings in the IO-Link Master Unit to an SD Memory Card*¹ inserted in the CPU Unit or to a specified memory device on the computer.
*1. For an NY-series Industrial PC, this is a Virtual SD Memory Card.
- 2** Use CX-ConfiguratorFDT to back up the parameter settings of the IO-Link devices to the specified memory in the computer.

Replacing the Unit and Devices

- 1** Turn OFF the Unit power supply and I/O power supply to the IO-Link Master Unit.
- 2** Replace the IO-Link Master Unit and IO-Link devices.
Refer to the *Basic Replacement Procedure for NX Units* for your Communications Coupler Unit for the replacement procedure for NX Units.

Restoring Backup Data

- 1** Turn ON the Unit power supply and I/O power supply to the IO-Link Master Unit.
- 2** Use the Sysmac Studio to restore the backed up IO-Link Master Unit parameter settings to the IO-Link Master Unit.
- 3** Use CX-ConfiguratorFDT to restore the backed up IO-Link device parameter settings to the IO-Link devices.



Additional Information

When you back up parameter settings for restored IO-Link devices to the IO-Link Master Unit, use the Sysmac Studio IO-Link Master Unit parameter settings to enable backup in the Backup Settings for the port.

For details on the IO-Link device backup method, refer to *Automatic Backup when IO-Link communications start* on page 7-16.



Precautions for Correct Use

After replacing an IO-Link device, check the following.

- The IO-Link device must be the correct model.
 - The device must be mounted at the correct position on the terminal block.
 - The IO-Link device must be set correctly and operate correctly.
-



Appendices

A-1	Other System Configurations	A-2
A-1-1	Using a Controller from Another Company with EtherCAT Communications	A-2
A-1-2	Using an NJ/NX-series CPU Unit or NY-series Industrial PC with EtherNet/IP Communications	A-10
A-1-3	Using a CJ/CP/CS-series PLC or a Controller from Another Company with EtherNet/IP Communications	A-16
A-2	Connected Device Specifications and Models	A-24
A-3	How to Access the IO-Link Devices with Message Communications	A-28
A-3-1	Applicable System Configurations	A-28
A-3-2	Overview of Access Methods	A-29
A-3-3	Details on Access Methods	A-33
A-4	Precautions When Using the OMRON EtherNet/IP with CX-ConfiguratorFDT	A-39

A-1 Other System Configurations

This section describes the configurations of the following IO-Link Systems.

- Using a controller from another company with EtherCAT communications
- Using an NJ/NX-series CPU Unit or NY-series Industrial PC with EtherNet/IP communications
- Using a CJ/CP/CS-series PLC or a controller from another company with EtherNet/IP communications

A-1-1 Using a Controller from Another Company with EtherCAT Communications

System Configuration

This section describes the system configuration when a controller from another company is used with EtherCAT communications.

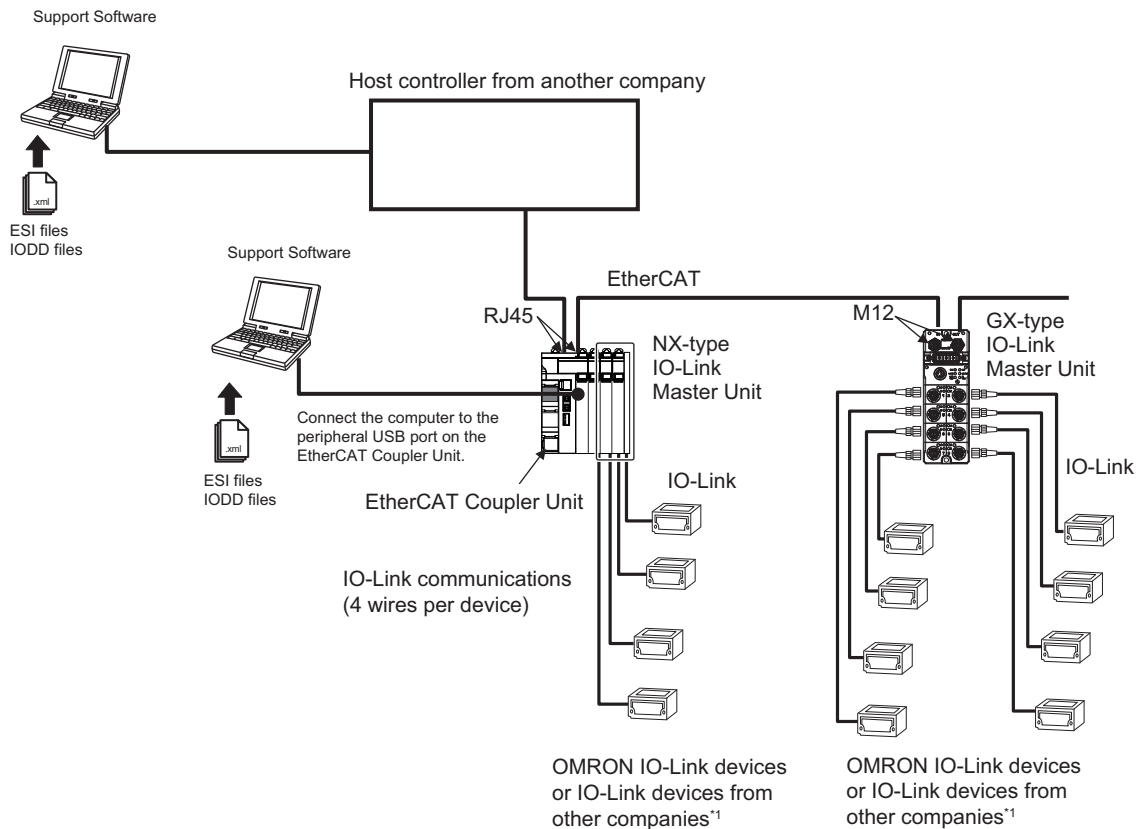

*1. You can also connect a combination of general-purpose sensors and other devices.

Applicable Support Software

IO-Link Master Unit type	Applicable Support Software		
	I/O allocation settings (NX) PDO allocation settings (GX)	IO-Link Master Unit settings* ¹	Setting and monitoring the IO-Link devices
NX	EtherCAT software application from the other company	Sysmac Studio	CX-ConfiguratorFDT* ²
GX	EtherCAT software application from the other company	EtherCAT software application from the other company	* ³

*1. The IO-Link device connection configuration information settings are included in the IO-Link Master Unit settings.

*2. CX-ConfiguratorFDT version 2.2 or higher is required.

*3. Make the settings with message communications from the controller from another company.

Communications

Yes: Can be used. No: Cannot be used.

IO-Link Master Unit type	Cyclic communications	Message communications
NX	Yes	Yes* ¹
GX	Yes	Yes

*1. You cannot use an EtherCAT master from another company for message communications with the IO-Link Master Unit or the devices when using the EtherCAT Coupler Unit with unit version 1.4 or earlier. Message communications are possible with unit version 1.5 or later.

Communications Methods

● Cyclic Communications

Applicable master and devices		Required action
NX-type IO-Link Master Unit	OMRON IO-Link devices or IO-Link devices from other companies	<ul style="list-style-type: none"> I/O allocation settings from the Sysmac Studio are not necessary for an IO-Link device with an IO-Link input data size of 2 bytes or an IO-Link output data size of 2 bytes. I/O allocation from the Sysmac Studio is necessary for all other IO-Link devices.
GX-type IO-Link Master Unit		<ul style="list-style-type: none"> I/O allocation settings from the EtherCAT software application from the other company are not necessary for an IO-Link device with an IO-Link input data size of 2 bytes or an IO-Link output data size of 2 bytes. I/O allocation from the EtherCAT software application from the other company is necessary for all other IO-Link devices.

● **Message Communications**

Applicable master or device	Communications instructions used	Required action
NX-type IO-Link Master Unit	Use SDO communications instructions from the controller from the other company.	<ul style="list-style-type: none"> You must make EtherCAT configuration settings from the EtherCAT software application from the other company. You must make Slave Terminal configuration settings from the Sysmac Studio.
GX-type IO-Link Master Unit		You must make EtherCAT configuration settings from the EtherCAT software application from the other company.
I/O device connected to an NX-type IO-Link Master Unit		<ul style="list-style-type: none"> You must make EtherCAT configuration settings from the EtherCAT software application from the other company. You must make Slave Terminal configuration settings from the Sysmac Studio.
I/O device connected to a GX-type IO-Link Master Unit		You must make EtherCAT configuration settings from the EtherCAT software application from the other company.

Basic Application Procedure

● **Using a GX-type IO-Link Master Unit**

Step	Contents	EtherCAT software application from the other company	SDO communications instructions used for settings
1. Mounting and Hardware Settings	Set the node addresses.	---	---
↓			
2. EtherCAT Communications Cable Wiring and IO-Link Port Wiring	---	---	---
↓			
3. Registering the IO-Link Master Unit in the EtherCAT Network Configuration	Register the GX-type IO-Link Master Unit in the EtherCAT network configuration.	Perform the operation from the EtherCAT software application from the other company.	---
↓			
4. IO-Link Master Unit Settings (Parameter Settings and I/O Allocation Settings)	Set the parameters for the GX-type IO-Link Master Unit and make the EtherCAT I/O allocation settings for the I/O data.	Use the EtherCAT software application from the other company.	---
Parameter Settings	The parameters include the communications mode and IO-Link Device Configuration Settings for each port.		---
PDO Mapping (Allocation of I/O Data)	Add PDO entries for the connected IO-Link devices to the default PDO mapping. ^{*1}		---
↓			

Step	Contents	EtherCAT software application from the other company	SDO communications instructions used for settings
5. Programming			
Cyclic Communications	Use the software application from the other company to write the programming for the I/O data (using the Input Data Enabled Flag as an input condition).	Use the EtherCAT software application from the other company.	---
Message Communications	Program SDO communications instructions for the objects in the IO-Link Master Units and the IO-Link devices.	Use the EtherCAT software application from the other company.	---
↓			
6. Turning ON the Power Supply and Going Online with the EtherCAT Software Application from the Other Company	Turn ON the power supply to the entire system and connect the EtherCAT software application from the other company.	Use the EtherCAT software application from the other company.	---
↓			
7. Downloading the Network Configuration Information and User Program to the CPU Unit		Use the EtherCAT software application from the other company.	---
↓			
8. Parameter Settings for IO-Link Devices (as Required)	If the default values are acceptable or if you set the parameters with the actual devices, you do not need to change any settings.	---	Use the method described in step 9.
↓			
9. Downloading Parameter Settings to IO-Link Devices (as Required)	Same as above.	---	(Use SDO communications instructions from the controller from the other company to make settings through gateway objects for IO-Link devices connected to the GX-type IO-Link Master Unit, or use a commercially-available IO-Link USB master to make settings from CX-ConfiguratorFDT.)
↓			
10. Checking the Indicators on the IO-Link Master Unit and the IO-Link Devices	---	---	---
↓			
11. Checking the Error Status of the IO-Link Master Unit Ports and the IO-Link Devices	---	---	---

*1. The default data size for each IO-Link device is 2 input bytes or 2 output bytes. The maximum data size for each device is 32 bytes.

For example, for OMRON IO-Link devices such as the E2E and E3Z, the default values can be used, and no additional PDO entries are necessary.

For other I/O devices, such as those from other companies, additional PDO entries for the I/O data sizes of those devices are required.

● Using an NX-type IO-Link Master Unit

Step	Contents	Sysmac Studio operation *1	CX-ConfiguratorFDT operation
1. Mounting and Hardware Settings	Connect to the Communications Coupler Unit.	---	---
↓			
2. EtherCAT Communications Cable Wiring and IO-Link Port Wiring	---	---	---
↓			
3. Registering the IO-Link Master Unit in the EtherCAT Network Configuration	Register the EtherCAT Coupler Unit and the NX-type IO-Link Master Unit in the EtherCAT network configuration.	Drag the EtherCAT Coupler Unit to under the master in the EtherCAT Configuration Edit Tab Page, and register the NX-type IO-Link Master Unit with the Edit Slave Terminal Configuration Button.	---
↓			
4. IO-Link Master Unit Settings (Parameter Settings and I/O Allocation Settings)	Set the parameters for the NX-type IO-Link Master Unit and make the EtherCAT I/O allocation settings for the I/O data.	Select the IO-Link Master Unit under EtherCAT in Configurations and Setup , then set the following.	---
Parameter Settings	The parameters include the communications mode and IO-Link Device Configuration Settings for each port.	Edit Unit Operation Settings Button	---
I/O Entry Mapping (Allocation of I/O Data)	Add PDO entries to the default I/O entry mapping for the connected IO-Link devices.*2	Edit I/O Entry Map Settings Button	---
↓			

Step	Contents	Sysmac Studio operation *1	CX-ConfiguratorFDT operation
5. Programming			
Cyclic Communications	Use the software application from the other company to write the programming for the I/O data (using the Input Data Enabled Flag as an input condition).	Use the software application from the other company.	---
Message Communications	Program SDO communications instructions for the objects in the IO-Link Master Units and the IO-Link devices.	Use the software application from the other company.	
⇩			
6. Turning ON Power and Going Online from the Sysmac Studio	Turn ON the power to the Slave Terminal and IO-Link devices and connect the Sysmac Studio to the USB port on the EtherCAT Coupler Unit.	Coupler Connection USB - Online	---
⇩			
7. Downloading EtherCAT Slave Terminal Settings	---	Coupler Connection USB - Transfer to Coupler	---
⇩			
8. Going Offline from Sysmac Studio and Turning ON the Power of the Master from the Other Company	---	Coupler Connection USB - Offline	---
⇩			
9. Reading the I/O Allocation Settings (PDO Map Settings) of the EtherCAT Slave Terminal	---	Use the software application from the other company.	---
⇩			
10. Downloading the Network Configuration Information and Program to the Master from the Other Company	<ul style="list-style-type: none"> • Create the network configuration information (ENI) based on the read EtherCAT Slave Terminal information and download the information to the master from the other company. • Download the program to the master from the other company. 	Use the software application from the other company.	---
⇩			
11. Parameter Settings for IO-Link Devices (as Required)	If the default values are acceptable or if you set the parameters with the actual devices, you do not need to change any settings.	---	Place the device DTMs of the IO-Link devices under NX Coupler USB - NX-ILM400 . Set the IO-Link device parameters.

Step	Contents	Sysmac Studio operation ^{*1}	CX-ConfiguratorFDT operation
12. Downloading Parameter Settings to IO-Link Devices (as Required)	Same as above.	---	Connect CX-ConfiguratorFDT to the EtherCAT Coupler Unit, and download the parameters from the IO-Link devices.
↓			
13. Checking the Indicators on the IO-Link Master Unit and the IO-Link Devices	---	---	---
↓			
14. Checking the Error Status of the IO-Link Master Unit Ports and the IO-Link Devices	---	---	---

*1. If operation with Support Software other than Sysmac Studio is required, that Support Software is mentioned.

*2. The default data size for each IO-Link device is 2 input bytes or 2 output bytes. The maximum data size for each device is 32 bytes.

For example, for OMRON IO-Link devices such as the E2E and E3Z, the default values can be used, and no additional PDO entries are necessary.

For other I/O devices, such as those from other companies, additional PDO entries for the I/O data sizes of those devices are required.

● Flow of Operations for the Sysmac Studio

Use the Sysmac Studio to make settings for the NX-type IO-Link Master Unit when you use a controller from another company with EtherCAT communications, as described below.

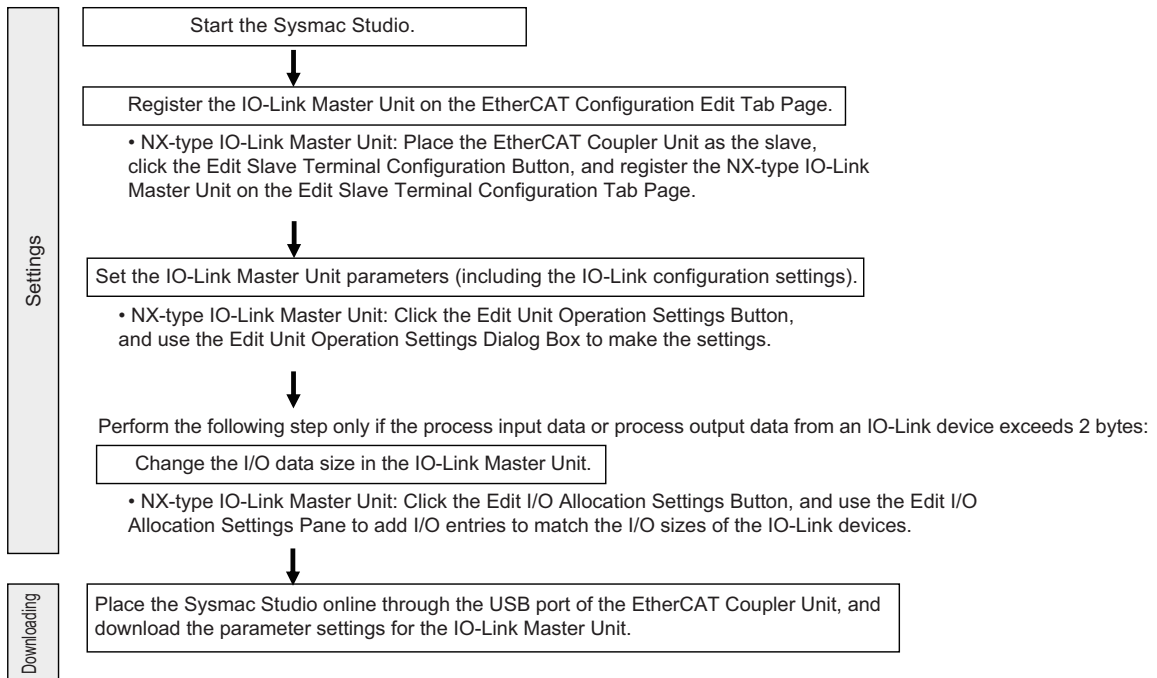

Note: Use the software application from the other company to perform PDO allocations for EtherCAT communications and to program the controller.

A-1-2 Using an NJ/NX-series CPU Unit or NY-series Industrial PC with EtherNet/IP Communications

This section describes the system configuration when an NJ/NX-series CPU Unit or NY-series Industrial PC is used as a controller with EtherNet/IP communications.



Precautions for Correct Use

The combination of the following unit versions is required in a system configuration that uses an NJ/NX-series CPU Unit or NY-series Industrial PC with EtherNet/IP communications.

- NJ/NX-series CPU Unit or NY-series Industrial PC
Version 1.14 or later
- EtherNet/IP Coupler Unit
Version 1.2 or later

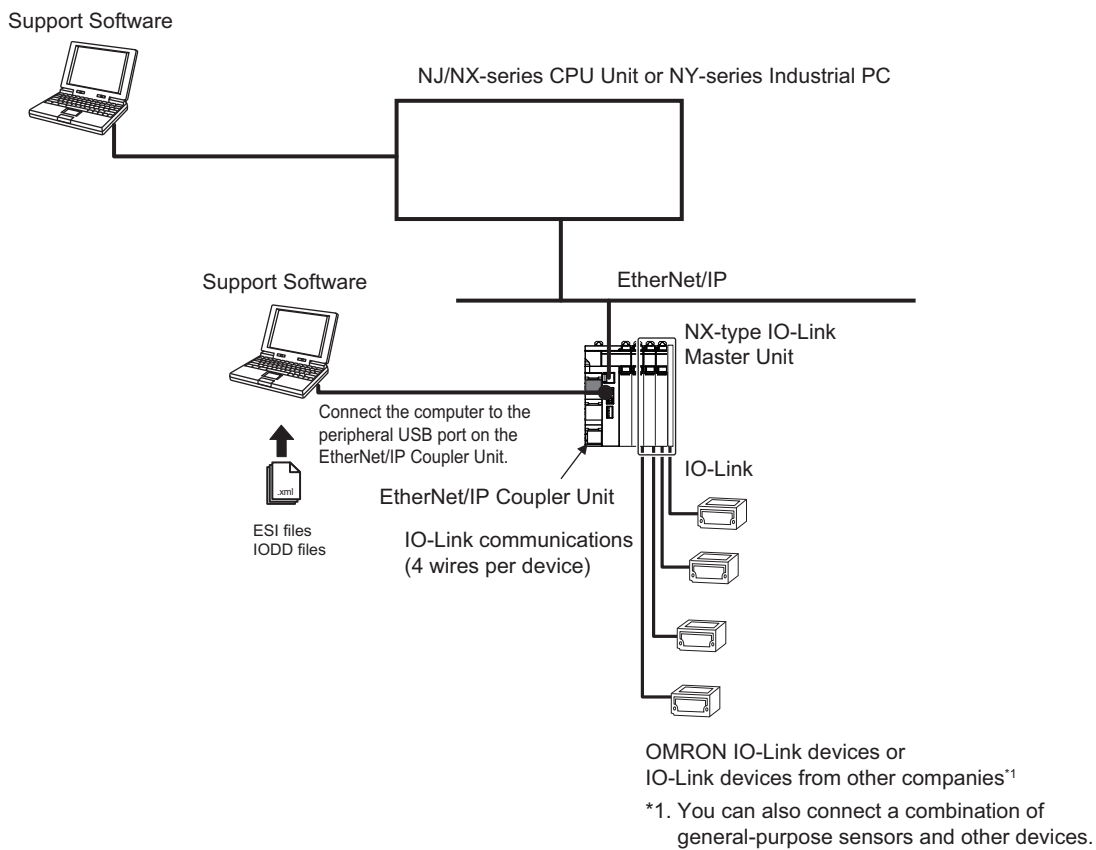

Applicable Support Software

IO-Link Master Unit type	Applicable Support Software		
	Tag data link settings	IO-Link Master Unit settings ^{*1}	Setting and monitoring the IO-Link devices
NX	Sysmac Studio or Network Configurator	Sysmac Studio	CX-ConfiguratorFDT

*1. The IO-Link device connection configuration information settings are included in the IO-Link Master Unit settings.

Communications

Yes: Can be used. No: Cannot be used.

IO-Link Master Unit type	Cyclic communications	Message communications
NX	Yes	Yes ^{*1}

*1. The EtherNet/IP Coupler Unit with unit version 1.2 or later is required to use this function.

Communications Methods

● Cyclic Communications

Applicable master and devices		Required action
NX-type IO-Link Master Unit	OMRON IO-Link devices or IO-Link devices from other companies	<ul style="list-style-type: none"> I/O allocation settings from the Sysmac Studio are not necessary for an IO-Link device with an IO-Link input data size of 2 bytes or an IO-Link output data size of 2 bytes. I/O allocation from the Sysmac Studio is necessary for all other IO-Link devices.

● Message Communications

Applicable master or device	Communications instructions used	Required action
NX-type IO-Link Master Unit	CIPSend (Send Explicit Message) instruction or CIPUCMMSend (Send Explicit Message) instruction ^{*1}	You must make EtherNet/IP configuration settings and Slave Terminal configuration settings from the Sysmac Studio. ^{*2}
I/O device connected to an NX-type IO-Link Master Unit	CIPSend (Send Explicit Message) instruction or CIPUCMMSend (Send Explicit Message) instruction ^{*1*3}	

*1. The controller can access the relevant NX objects of the IO-Link Master Unit using the CIP object (i.e., Read NX object (33 hex) or Write NX object (34 hex)) of the EtherNet/IP Coupler Unit. For details, refer to the *NX-series EtherNet/IP Coupler Unit User's Manual* (Cat. No. W536).

*2. The EtherNet/IP configuration settings can also be set with Network Configurator.

*3. For details on how to access the data of an IO-Link device, refer to *A-3 How to Access the IO-Link Devices with Message Communications* on page A-28.

● Using an NX-type IO-Link Master Unit

Step	Contents	Sysmac Studio operation	CX-ConfiguratorFDT operation
1. Mounting and Hardware Settings	Connect to the Communications Coupler Unit.	---	---
↓			
2. Ethernet Communications Cable Wiring and IO-Link Port Wiring	---	---	---
↓			
3. Registering the IO-Link Master Unit in the EtherNet/IP Slave Terminal	Register the NX-type IO-Link Master Unit in the EtherNet/IP Slave Terminal.	Register the NX-type IO-Link Master Unit on the Edit EtherNet/IP Slave Terminal Configuration Tab Page	---
↓			
4. IO-Link Master Unit Settings (Parameter Settings and I/O Allocation Settings)	Set the parameters for the IO-Link Master Unit and make the EtherNet/IP I/O allocation settings for the I/O data.	Select the IO-Link Master Unit under EtherNet/IP in Configurations and Setup , then set the following.	---
Parameter Settings	The parameters include the communications mode and IO-Link Device Configuration Settings for each port.	Edit Unit Operation Settings Button	---
I/O Entry Mapping (Allocation of I/O Data)	Add I/O entries to the default I/O entry mapping for the connected IO-Link devices.*1	Edit I/O Allocation Settings Button	---
↓			
5. Turning ON Power and Going Online from the Sysmac Studio	Connect the Sysmac Studio to the USB port on the EtherNet/IP Coupler Unit.	Coupler Connection USB - Online	---
↓			
6. Downloading EtherNet/IP Slave Terminal Settings and Going Offline from the Sysmac Studio	---	<ul style="list-style-type: none"> • Coupler Connection USB - Transfer to Coupler • Coupler Connection USB - Offline 	---
↓			
7. Checking the I/O Sizes in the EtherNet/IP Coupler Unit	Display the I/O allocations from Sysmac Studio and check the sizes of the I/O data in the EtherNet/IP Coupler Unit.	<ul style="list-style-type: none"> • Right-click the EtherNet/IP Coupler Unit and select Display I/O Allocation. • Check the sizes of the I/O data in the EtherNet/IP Coupler Unit. 	---
↓			

Step	Contents	Sysmac Studio operation	CX-ConfiguratorFDT operation
8. Tag Data Link Settings	Set the tag data links for the I/O data in the EtherNet/IP Coupler Unit as EtherNet/IP Slave Terminal tags (i.e., tag sets).	Set the tag data links from Sysmac Studio.	---
↓			
9. Programming			
Cyclic Communications	In the user program, specify the variables allocated to the tags (i.e., tag sets) of the EtherNet/IP Slave Terminal that are equivalent to the I/O data of the IO-Link Master Unit. Use the Input Data Enabled Flags as input conditions.	Create the programs with POUs under Programming .	---
Message Communications	Program communications instructions for the objects in the IO-Link Master Unit and the IO-Link devices.	Create the programs with POUs under Programming .	---
↓			
10. Going Online from the Sysmac Studio	---	Select Online under Controller to go online.	---
↓			
11. Downloading the Tag Data Link Settings and Program to the CPU Unit or Industrial PC	---	Select Synchronization - Transfer To Controller under Controller to download the tag data link settings and user program.	---
↓			
12. Parameter Settings for IO-Link Devices (as Required)	If the default values are acceptable or if you set the parameters with the actual devices, you do not need to change any settings.	---	Place the device DTMs of the IO-Link devices under NX Coupler USB - NX-ILM400 or OMRON EtherNet/IP - NX-EIC Coupler - NX-ILM400 . Set the IO-Link device parameters.
↓			
13. Downloading Parameter Settings to IO-Link Devices (as Required)	Same as above.	---	Connect CX-ConfiguratorFDT to the EtherNet/IP Coupler Unit, and download the parameters from the IO-Link devices.
↓			

Step	Contents	Sysmac Studio operation	CX-Configurator/FDT operation
14. Checking the Indicators on the IO-Link Master Unit and the IO-Link Devices	---	---	---
↓			
15. Checking the Error Status of the IO-Link Master Unit Ports and the IO-Link Devices	---	---	---

*1. The default data size for each IO-Link device is 2 input bytes or 2 output bytes. The maximum data size for each device is 32 bytes.
 For example, for OMRON IO-Link devices such as the E2E and E3Z, the default values can be used, and no additional I/O entries are necessary.
 For other I/O devices, such as those from other companies, additional I/O entries for the I/O data sizes of those devices are required.

● Flow of Operations for the Sysmac Studio

The flow for making the settings for the NX-type IO-Link Master Unit from Sysmac Studio is described below when you use an NJ/NX-series CPU Unit or NY-series Industrial PC with EtherNet/IP communications.

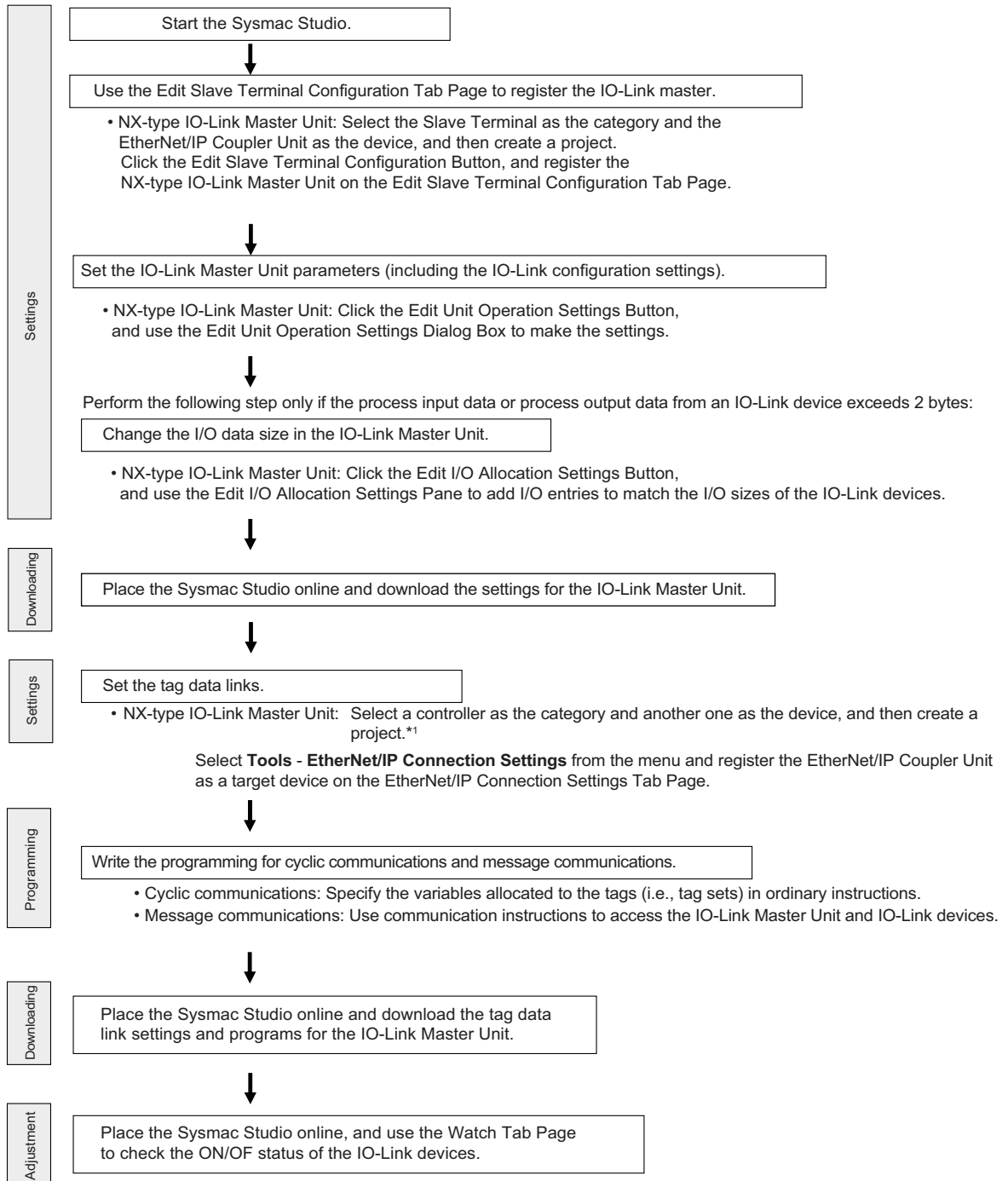

*1. In the Edit EtherNet/IP Slave Terminal Configuration Tab Page, even if a CPU Unit or an Industrial PC that you use is selected from **Insert - Controller** under the menu, you can add a controller.

A-1-3 Using a CJ/CP/CS-series PLC or a Controller from Another Company with EtherNet/IP Communications

System Configuration

This section describes the system configuration when a CJ/CP/CS-series PLC or a controller from another company is used with EtherNet/IP communications.

Support Software

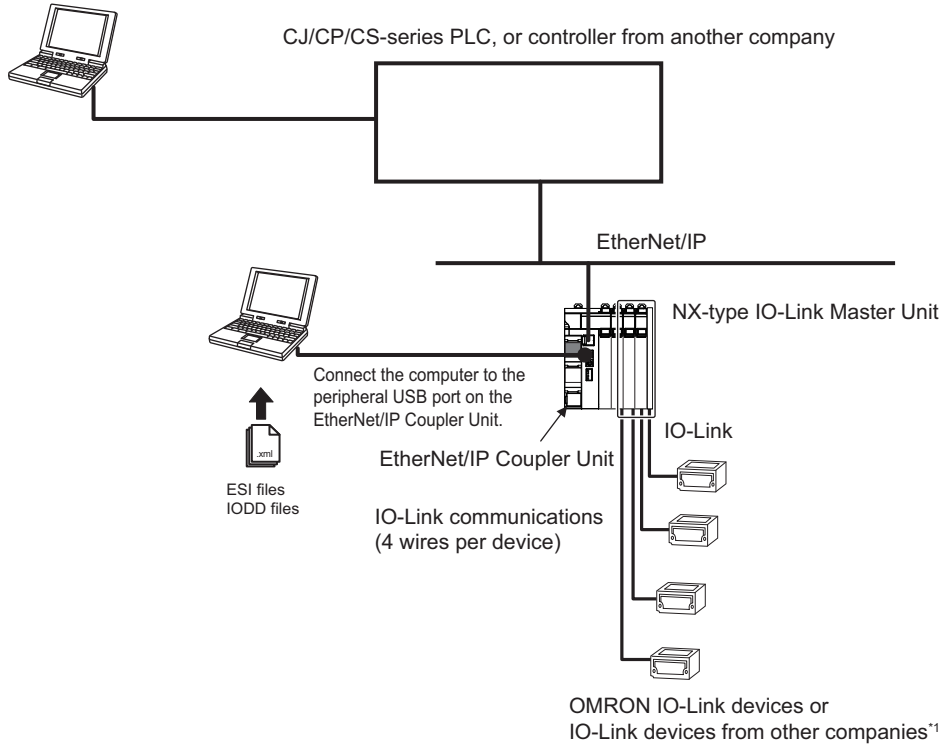

*1. You can also connect a combination of general-purpose sensors and other devices.

Applicable Support Software

IO-Link Master Unit type	Applicable Support Software		
	Tag data link settings	IO-Link Master Unit settings ^{*1}	Setting and monitoring the IO-Link devices
NX	Use the Network Configurator or the EtherNet/IP software application from the other company.	IO-Link Master Unit Configuration Tool <ul style="list-style-type: none"> • Sysmac Studio^{*2} • NX-IO Configurator^{*3} 	CX-ConfiguratorFDT

*1. The IO-Link device connection configuration information settings are included in the IO-Link Master Unit settings.

*2. The settings from the Sysmac Studio are required when you use the Safety Control Unit on the Slave Terminal. The Safety Control Unit is not supported with the NX-IO Configurator.

*3. The connectable paths of NX-IO Configurator differ depending on the unit version of the EtherNet/IP Coupler Unit. For details on the connection paths of NX-IO Configurator, refer to the *NX-IO Configurator Operation Manual* (Cat. No. W585).

Communications

Yes: Can be used. No: Cannot be used.

IO-Link Master Unit type	Cyclic communications	Message communications
NX	Yes	Yes ^{*1}

*1. Any of message communications to the IO-Link Master Unit and message communications to the IO-Link devices are not possible for the EtherNet/IP Coupler Unit with unit version 1.1 or earlier. Message communications are possible with unit version 1.2 or later.

Communications Methods

● Cyclic Communications

Applicable master and devices		Required action
NX-type IO-Link Master Unit	OMRON IO-Link devices or IO-Link devices from other companies	<ul style="list-style-type: none"> I/O allocation settings from the Sysmac Studio are not necessary for an IO-Link device with an IO-Link input data size of 2 bytes, and an IO-Link output data size of 2 bytes. I/O allocation from the Sysmac Studio is necessary for all other IO-Link devices.

● Message Communications



Precautions for Correct Use

Any of message communications to the IO-Link Master Unit and message communications to the IO-Link devices are not possible for the EtherNet/IP Coupler Unit with unit version 1.1 or earlier. Message communications are possible with unit version 1.2 or later.

Applicable master or device	Communications instructions used	Required action
NX-type IO-Link Master Unit	<ul style="list-style-type: none"> CJ/CP/CS-series PLC: CMND instruction (FINS 2810) Controller from another company: Explicit message of controller from another company^{*1} 	<ul style="list-style-type: none"> You must make EtherNet/IP configuration settings from Network Configurator or the EtherNet/IP software application from the other company. You must make Slave Terminal configuration settings from the IO-Link Master Unit Configuration Tool.
I/O device connected to an NX-type IO-Link Master Unit	<ul style="list-style-type: none"> CJ/CP/CS-series PLC: <code>_IOL003_ReadObjEip</code> and <code>_IOL003_WriteObjEip</code>^{*2} Controller from another company: Explicit message of controller from another company^{*1*3} 	

*1. The controller can access the relevant NX objects of the IO-Link Master Unit using the CIP object (i.e., Read NX object (33 hex) or Write NX object (34 hex)) of the EtherNet/IP Coupler Unit. For details, refer to the *NX-series EtherNet/IP Coupler Unit User's Manual* (Cat. No. W536).

*2. This is the Smart FB.

*3. For details on how to access the data of an IO-Link device, refer to *A-3 How to Access the IO-Link Devices with Message Communications* on page A-28.

Basic Application Procedure

● Using Only NX-type IO-Link Master Units

Step	Contents	IO-Link Master Unit Configuration Tool operation *1	CX-ConfiguratorFDT operation
1. Mounting and Hardware Settings	Connect to the Communications Coupler Unit.	---	---
↓			
2. Ethernet Communications Cable Wiring and IO-Link Port Wiring	---	---	---
↓			
3. Registering the IO-Link Master Unit in the EtherNet/IP Slave Terminal	Register the NX-type IO-Link Master Unit in the EtherNet/IP Slave Terminal.	Register the NX-type IO-Link Master Unit on the Edit EtherNet/IP Slave Terminal Configuration Tab Page.	---
↓			
4. IO-Link Master Unit Settings (Parameter Settings and I/O Allocation Settings)	Set the parameters for the IO-Link Master Unit and make the EtherNet/IP I/O allocation settings for the I/O data.	Select the IO-Link Master Unit under EtherNet/IP in Configurations and Setup , then set the following.	---
Parameter Settings	The parameters include the communications mode and IO-Link Device Configuration Settings for each port.	Edit Unit Operation Settings Button	---
I/O Entry Mapping (Allocation of I/O Data)	Add I/O entries to the default I/O entry mapping for the connected IO-Link devices.*2	Edit I/O Allocation Settings Button	---
↓			
5. Turning ON the Power and Going Online from the IO-Link Master Unit Configuration Tool	When using NX-IO Configurator, go online using any of the following paths. <ul style="list-style-type: none"> • Via OMRON Controller • Via EtherNet/IP • USB port on the EtherNet/IP Coupler Unit When using Sysmac Studio, go online by connecting to the USB port on the EtherNet/IP Coupler Unit.	In the case of via an OMRON Controller or Ethernet/IP, make the communications settings and then go online. In the case of connecting to the USB port on the EtherNet/IP Coupler Unit, select Coupler Connection USB - Online to go online.	---
↓			

Step	Contents	IO-Link Master Unit Configuration Tool operation*1	CX-ConfiguratorFDT operation
6. Downloading EtherNet/IP Slave Terminal Settings and Going Online from the IO-Link Master Unit Configuration Tool	---	<ul style="list-style-type: none"> • Coupler Connection USB - Transfer to Coupler • Select Coupler Connection USB - Offline to go offline. 	---
↓			
7. Checking the I/O Sizes in the EtherNet/IP Coupler Unit	<p>Use one of the following methods to check the sizes of the I/O data in the EtherNet/IP Coupler Unit.</p> <ul style="list-style-type: none"> • Display the I/O allocations from the IO-Link Master Unit Configuration Tool. • Upload the Slave Terminal parameters with the Network Configurator or the EtherNet/IP software application from the other company. 	<ul style="list-style-type: none"> • Right-click the EtherNet/IP Coupler Unit and select Display I/O Allocation. • Use the Network Configurator or the EtherNet/IP software application from the other company to check the sizes of the I/O data in the EtherNet/IP Coupler Unit. 	---
↓			
8. Tag Data Link Settings	Set the tag data links for the I/O data in the Ethernet/IP Coupler Unit as EtherNet/IP Slave Terminal tags (i.e., tag sets).	(Use the Network Configurator or the EtherNet/IP software application from the other company to set the tag data links.)	---
↓			

Step	Contents	IO-Link Master Unit Configuration Tool operation *1	CX-ConfiguratorFDT operation
9. Programming			
Cyclic Communications	In the user program, specify the variables allocated to the tags (i.e., tag sets) of the EtherNet/IP Slave Terminal that are equivalent to the I/O data of the IO-Link Master Unit (set the Input Data Enabled flags as input conditions).	Use the CX-Programmer or the software application from another company.	---
Message Communications	Program communications instructions for the objects in the IO-Link Master Unit or the IO-Link devices. For the CJ/CP/CS-series PLC, program the Smart FB that can access the IO-Link devices.	Use the CX-Programmer or the software application from another company.	---
Downloading Programming	---	Use the CX-Programmer or the software application from another company.	
↓			
10. Downloading the Tag Data Link Parameters	---	Use the Network Configurator or the EtherNet/IP software application from another company.	---
↓			
11. Parameter Settings for IO-Link Devices (as Required)	If the default values are acceptable or if you set the parameters with the actual devices, you do not need to change any settings.	---	Place the device DTMs of the IO-Link devices under NX Coupler USB - NX-ILM400 or OMRON EtherNet/IP - NX-EIC Coupler - NX-ILM400 . Set the IO-Link device parameters.
↓			
12. Downloading Parameter Settings to IO-Link Devices (as Required)	Same as above.	---	Connect CX-ConfiguratorFDT via an OMRON Controller or EtherNet/IP or to the EtherNet/IP Coupler Unit, and download the parameters from the IO-Link devices. *3
↓			
13. Checking the Indicators on the IO-Link Master Unit and the IO-Link Devices	---	---	---
↓			

Step	Contents	IO-Link Master Unit Configuration Tool operation ^{*1}	CX-ConfiguratorFDT operation
14. Checking the Error Status of the IO-Link Master Unit Ports and the IO-Link Devices	---	---	---

- *1. If operation with Support Software other than the IO-Link Master Unit Configuration Tool is required, that Support Software is mentioned.
- *2. The default data size for each IO-Link device is 2 input bytes or 2 output bytes. The maximum data size for each device is 32 bytes.
 For example, for OMRON IO-Link devices such as the E2E and E3Z, the default values can be used, and no additional I/O entries are necessary.
 For other I/O devices, such as those from other companies, additional I/O entries for the I/O data sizes of those devices are required.
- *3. When connecting via an OMRON Controller or EtherNet/IP, use the CX-ConfiguratorFDT version 2.4 or higher.

● Flow of Operations for the IO-Link Master Unit Configuration Tool

The flow of operations when you use the IO-Link Master Unit Configuration Tool to make settings for the NX-type IO-Link Master Unit when you use a CJ/CP/CS-series PLC or a controller from another company is described below.

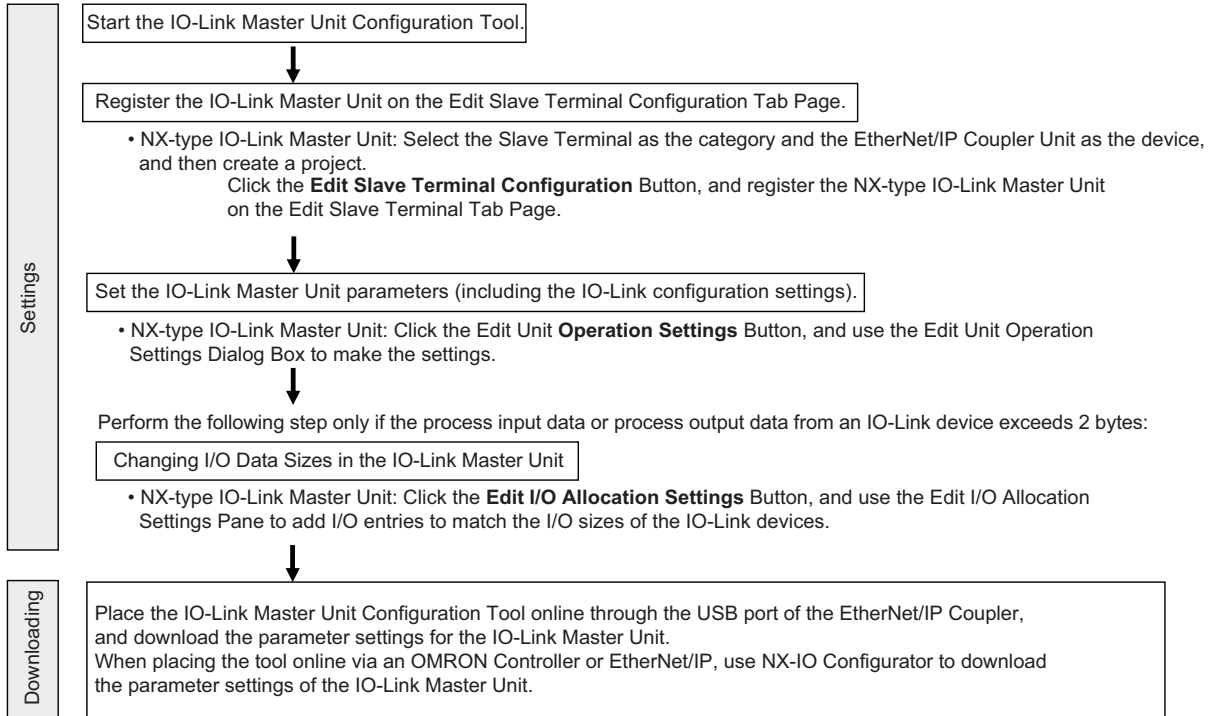

Note: Set the tag data links for EtherNet/IP communications with the Network Configurator or the EtherNet/IP software application from the other company.

Use the CX-Programmer to program the controller if it is an OMRON CJ/CP/CS-series Controller. If the controller is from another company, use the software application from that company to program the controller.

● Data Storage Order for CJ/CP/CS-series IO-Link Devices

The PD data for IO-Link devices is exchanged with the controller in the following order.

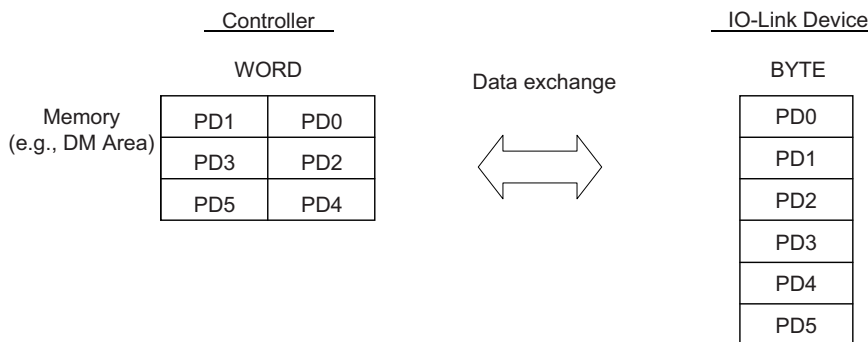

● Programming for Photoelectric Sensors

The following programming example is for when PD0 and PD1 are assigned to W000.

Refer to 9-5 *Allocating Variables to the I/O Ports* on page 9-7 for the PD format for Photoelectric Sensors.

● **Reading the Detected Light Level**

The Word Logical AND (ANDW) instruction is used for the detected light level and the upper byte is masked.

When W100.00 turns ON, the detected light level is read to W200.

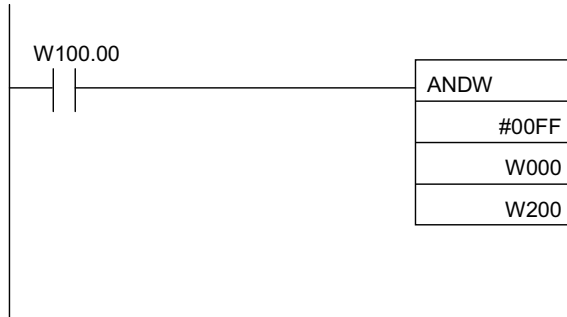

● **Reading Bit Status**

The status of sensor output 2 is read to W000.09.

● **Programming for Color Mark Sensors**

The following programming example is for when PD0 and PD1 are assigned to W000 and PD2 and PD3 are assigned to W001.

Refer to 9-5 *Allocating Variables to the I/O Ports* on page 9-7 for the PD format for Color Mark Sensors.

● **Reading the R Detected Light Level**

The Byte Swap (SWAP) instruction is used when reading the detected light level to swap the upper and lower bytes.

When W100.00 turns ON, the detected light level is read.

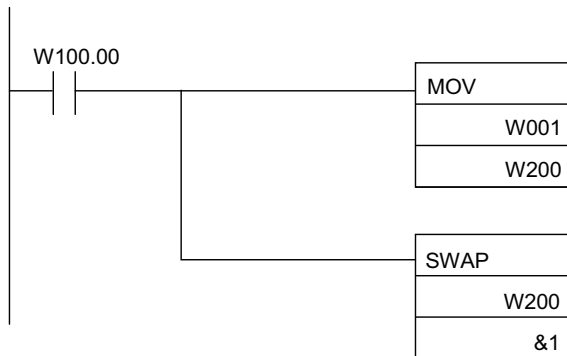

A-2 Connected Device Specifications and Models

EtherCAT Cables

- Cables to Connect a GX-type IO-Link Master Unit to a Master or Slave with an RJ45 Connector

Name and appearance	Specification	Number of cable conductors	Available connectors	Cable connection direction	Cable length	Model
XS5W Industrial Ethernet Connectors with Reinforced-shield Cable (Cable with Connectors on Both Ends (M12 Straight/RJ45)) 	M12 plug (D-coding, male) to RJ45	4	Smart-click connector	Straight/straight	0.5 m	XS5W-T421-BMC-SS
					1 m	XS5W-T421-CMC-SS
					2 m	XS5W-T421-DMC-SS
					3 m	XS5W-T421-EMC-SS
					5 m	XS5W-T421-GMC-SS
					10 m	XS5W-T421-JMC-SS

- Connects two GX-type IO-Link Master Units

Name and appearance	Specification	Number of cable conductors	Available connectors	Cable connection direction	Cable length	Model
XS5W Industrial Ethernet Connectors with Reinforced-shield Cable (Cable with Connectors on Both Ends (M12 Straight/M12 Straight)) 	M12 plug (D-coding, male) to M12 plug (D-coding, male)	4	Smart-click connector	Straight/straight	0.5 m	XS5W-T421-BM2-SS
					1 m	XS5W-T421-CM2-SS
					2 m	XS5W-T421-DM2-SS
					3 m	XS5W-T421-EM2-SS
					5 m	XS5W-T421-GM2-SS
					10 m	XS5W-T421-JM2-SS

Power Supply Cables for GX-type IO-Link Master Units

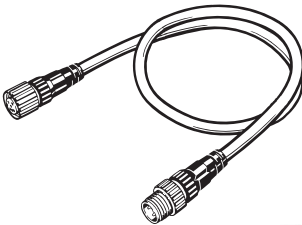
Name and appearance	Specification	Number of cable conductors	Available connectors	Cable connection direction	Cable length	Model
XS5F Connector with Cable, Socket on One End	M12 socket on one end (A-coding, female), for DC	4	Smart-click connector	Straight	1 m	XS5F-D421-C80-F
					2 m	XS5F-D421-D80-F
					3 m	XS5F-D421-E80-F
					5 m	XS5F-D421-G80-F
					10 m	XS5F-D421-J80-F
XS5W Connector with Cable (Socket on One End, Plug on Other End) 	M12 socket (A-coding, female) to M12 plug (A-coding, male), uses DC	4	Smart-click connector	Straight/straight	1 m	XS5W-D421-C81-F
					2 m	XS5W-D421-D81-F
					3 m	XS5W-D421-E81-F
					5 m	XS5W-D421-G81-F
					10 m	XS5W-D421-J81-F

I/O Cables for GX-type IO-Link Master Units

● Cables to Convert Connections from Sensors with M8 Plugs

Name and appearance	Specification	Number of cable conductors	Available connectors	Cable connection direction	Cable length	Model
XS3W Connector with Cable (M8 Socket/M12 Plug) 	M8 socket (A-coding, female) to M12 plug (A-coding, male), uses DC	4	M8 screw connector/M12 Smartclick connector	Straight	0.2 m	XS3W-M42C-4C2-A

● **Extension Cables from Sensors with M12 Plugs**

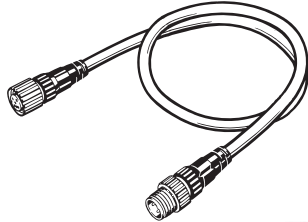
Name and appearance	Specification	Number of cable conductors	Available connectors	Cable connection direction	Cable length	Model
XS5W Connector with Cable (Socket on One End, Plug on Other End) 	M12 socket (A-coding, female) to M12 plug (A-coding, male), uses DC	4	Smart-click connector	Straight/straight	1 m	XS5W-D421-C81-F
					2 m	XS5W-D421-D81-F
					3 m	XS5W-D421-E81-F
					5 m	XS5W-D421-G81-F
					10 m	XS5W-D421-J81-F

I/O Cables for NX-type IO-Link Master Units

Use cables with a connector on one end to connect sensors. Refer to the catalog for the sensor for recommended products.

Power Supply T-Joint Connector

This connector is used when branching a GX-type Unit power supply.

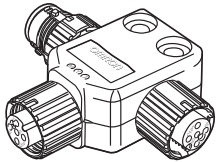
Name and appearance	Specification	Connector type	Model
XS5R Plug/Socket T-Joint Connector 	M12	Smartclick connector	XS5R-D427-5

Waterproof Cover for Connectors

This is a waterproof cover for unused M12 GX connectors (female).

When you use this waterproof cover, you can maintain the IP67 protective structure.

The following two types of covers are available. Either one can be mounted on an EtherCAT communications connector or I/O connector.

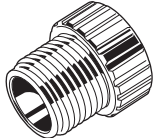
Name and appearance	Specification	Connector type	Materials	Model
M12 Threaded Waterproof Cover*1 	M12	Screw-type connector	Brass/nickel plated	XS2Z-22

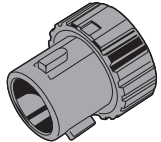
Name and appearance	Specification	Connector type	Materials	Model
Smartclick Waterproof Cover ^{*2} 	M12	Smartclick connector	PBT	XS5Z-11

- *1. When mounting the M12 Threaded Waterproof Cover on a connector, always tighten it to a torque of 0.39 to 0.49 N·m.
- *2. When mounting a Smartclick Waterproof Cover on a connector, torque management is not required.

Tool for M12 Threaded Connectors

The tool for tightening M12 Threaded Connectors is used when tightening to a specified torque.

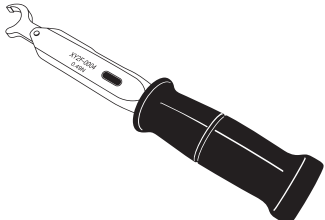
Name and appearance	Model
Torque Wrench 	XY2F-0004

A-3 How to Access the IO-Link Devices with Message Communications

This section describes how to access data in the IO-Link devices connected to the OMRON IO-Link Master Unit with message communications from the controller.

A-3-1 Applicable System Configurations

The following system configurations are applicable.

Communications with the controller	Controller	Communications Coupler Unit	IO-Link Master Unit
EtherCAT	Controller from another company	---	GX
		EtherCAT Coupler Unit* ¹	NX
EtherNet/IP	NJ/NX-series CPU Unit or NY-series Industrial PC	EtherNet/IP Coupler Unit* ²	
	Controller from another company		

*1. Use the EtherCAT Coupler Unit with unit version 1.5 or later.

*2. Use the EtherNet/IP Coupler Unit with unit version 1.2 or later.



Precautions for Correct Use

- When you connect an NX-type IO-Link Master Unit to an EtherCAT Coupler Unit and perform message communications with the IO-Link devices from the controller from another company, use the EtherCAT Coupler Unit with unit version 1.5 or later. For unit version 1.4 or earlier, IO-Link devices cannot be accessed by the message communications.
- When you connect an NX-type IO-Link Master Unit to an EtherNet/IP Coupler Unit and perform message communications with the IO-Link devices from the controller, use the EtherNet/IP Coupler Unit with unit version 1.2 or later. For unit version 1.1 or earlier, message communications are not possible.

A-3-2 Overview of Access Methods

The controller can access the IO-Link device via IO-Link communications by sending a message to the IO-Link Master Unit. The following shows an overview of access method for each type of controller communications.

EtherCAT Communications

- **GX-type IO-Link Master Units**

The following figure shows an overview of the access method for GX-type IO-Link Master Unit with EtherCAT. For details on how to access the relevant object of the IO-Link Master Unit, refer to *A-3-3 Details on Access Methods* on page A-33.

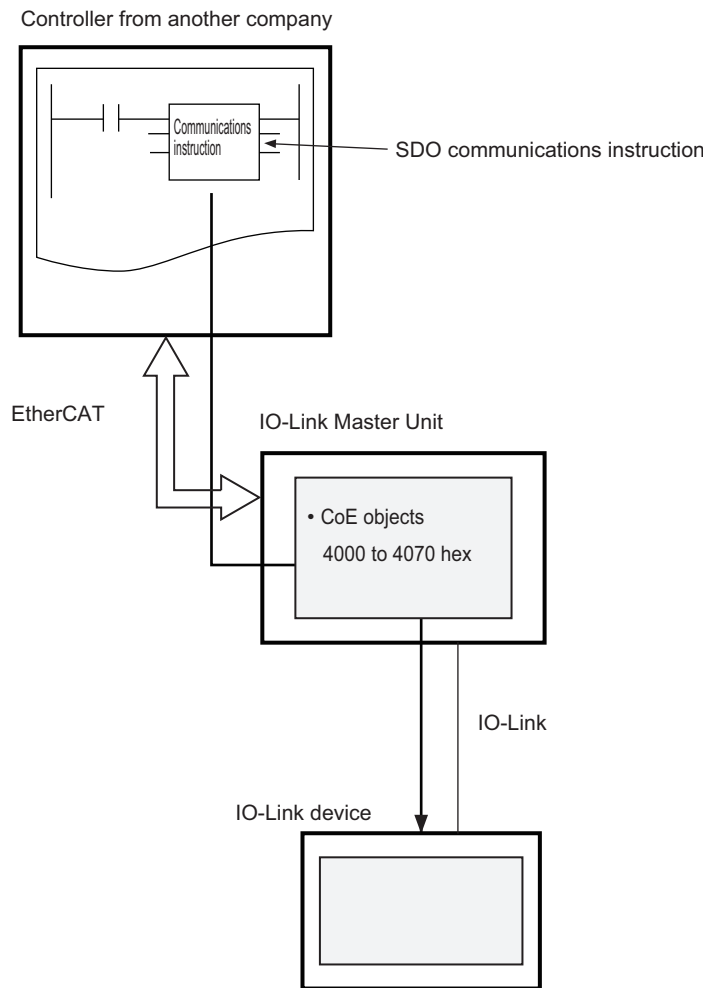

Controller	Communications Coupler Unit	IO-Link Master Unit	Communications instruction	Overview of access method
Controller from another company	---	GX	SDO communications instruction	The controller can access the following CoE objects of the IO-Link Master Unit. <ul style="list-style-type: none"> • 4000 to 4070 hex For details on the objects, refer to the <i>GX-series EtherCAT Slave Unit User's Manual (Cat. No. W488)</i> .

● **NX-type IO-Link Master Unit**

The following figure shows an overview of the access method for NX-type IO-Link Master Unit with EtherCAT. For details on how to access the relevant object of the IO-Link Master Unit, refer to A-3-3 *Details on Access Methods* on page A-33.

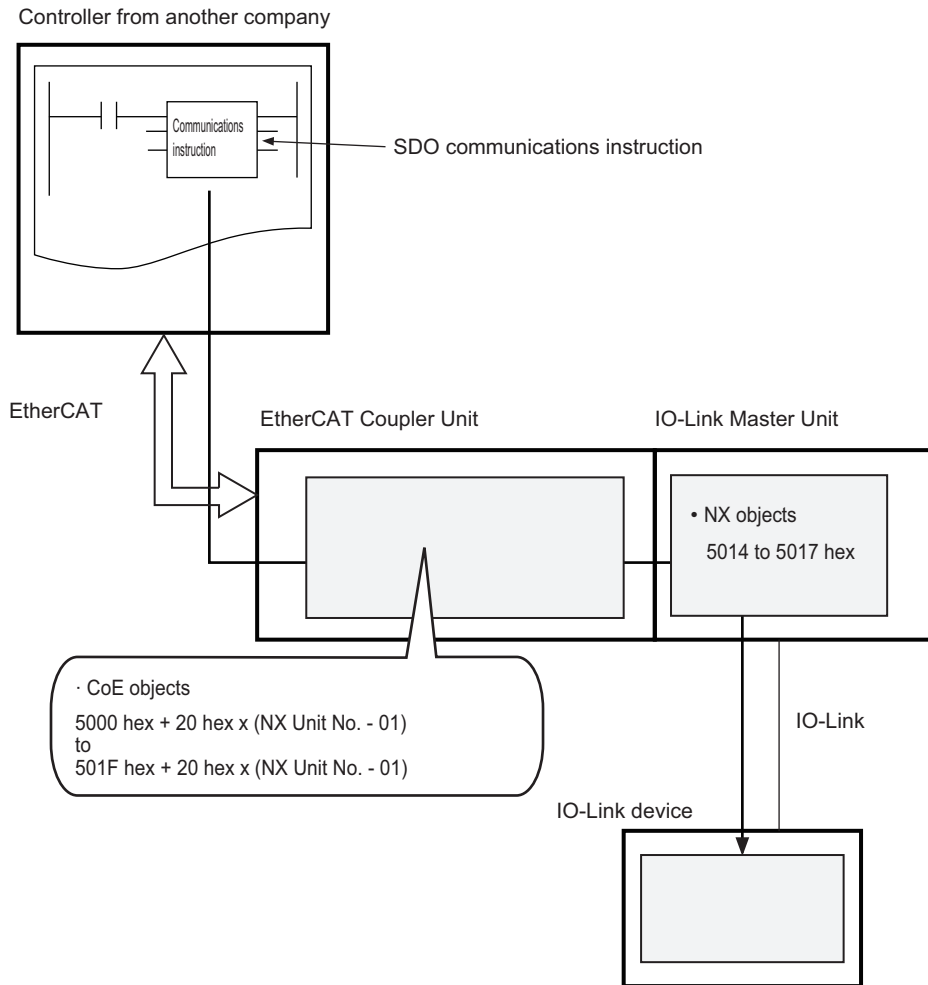

Controller	Communi- cations Coupler Unit	IO-Link Master Unit	Communi- cations instruction	Overview of access method
Controller from another company	EtherCAT Coupler Unit	NX	SDO communi- cations instruction	<p>The controller can access the relevant NX objects of the IO-Link Master Unit through the CoE objects which are supported by the EtherCAT Coupler Unit and which read or edit the Unit operation settings of an NX Unit.</p> <p>The objects that can be accessed are as follows:</p> <ul style="list-style-type: none"> • EtherCAT Coupler Unit 5000 hex + 20 hex x (NX Unit No. - 01) to 501F hex + 20 hex x (NX Unit No. - 01) • IO-Link Master Unit 5014 to 5017 hex <p>For details on the relevant CoE objects of the EtherCAT Coupler Unit, refer to the <i>NX-series EtherCAT Coupler Unit User's Manual</i> (Cat. No. 519).</p> <p>For details on the relevant objects of the IO-Link Master Unit, refer to the <i>NX-series IO-Link Master Unit User's Manual</i> (Cat. No. W567).</p>

EtherNet/IP Communications

The following figure shows an overview of the access method for NX-type IO-Link Master Unit with EtherNet/IP. For details on how to access the relevant object of the IO-Link Master Unit, refer to *A-3-3 Details on Access Methods* on page A-33.

NJ/NX-series CPU Unit, NY-series Industrial PC, or controller from another company

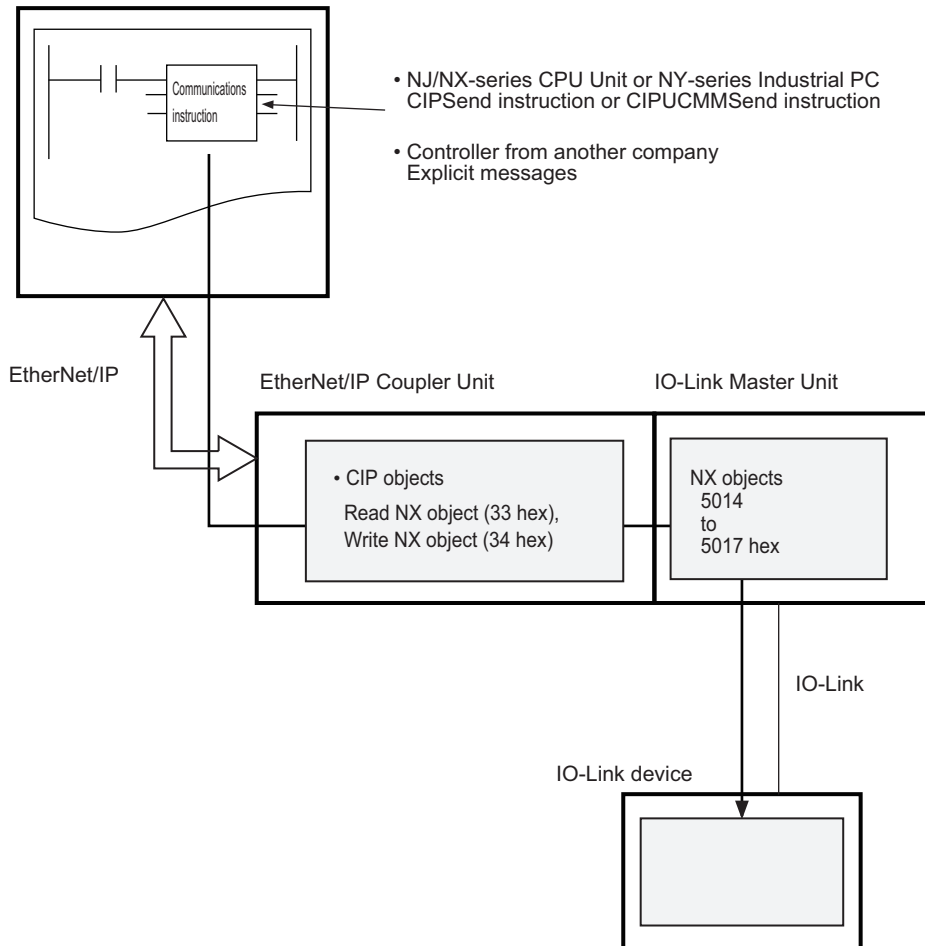

Controller	Communications Coupler Unit	IO-Link Master Unit	Communications instruction	Overview of access method
NJ/NX-series CPU Unit or NY-series Industrial PC	EtherNet/IP Coupler Unit	NX	CIPSend instruction or CIPUCMMSend instruction	The controller can access the relevant NX objects of the IO-Link Master Unit using the CIP object (i.e., Read NX object (33 hex) or Write NX object (34 hex)) of the EtherNet/IP Coupler Unit. The NX objects that can be accessed are as follows: <ul style="list-style-type: none"> • 5014 to 5017 hex For details on the relevant CIP objects of the EtherNet/IP Coupler Unit, refer to the <i>NX-series EtherNet/IP Coupler Unit User's Manual</i> (Cat. No. 536).
Controller from another company			Explicit messages	

A-3-3 Details on Access Methods

The following provides details on how to access the relevant object of the IO-Link Master Unit.

- Object formats
- Controller processing
- Restrictions

Object Formats

Objects are used to send messages to the IO-Link device of each port. Objects are called CoE objects in the case of the GX type and NX objects in the case of the NX type.

The formats of objects are shown below. It contains only the information necessary to explain the access procedures described later in this manual. For details on the relevant objects of the GX-type IO-Link Master Unit, refer to the *GX-series EtherCAT Slave Unit User's Manual* (Cat. No. W488). For details on the relevant objects of the NX-type IO-Link Master Unit, refer to the *NX-series IO-Link Master Unit User's Manual* (Cat. No. W567).

Object name		Reference	Default	Setting range	Attribute	GX		NX	
						Index	Sub-index	Index	Sub-index
Portn Mes- sage for IO-Link device *1	Control	<i>Control</i> on page A-33	00 hex	00 to 03 hex	RW	4000 hex + 10 hex x (port number -1)	01 hex	5014 hex + 01 hex x (port number -1)	01 hex
	Status	<i>Status</i> on page A-34	00 hex	00 to 05 hex	RO		02 hex		02 hex
	Index	<i>Index</i> on page A-34	0000 hex	0000 to FFFF hex	RW		03 hex		03 hex
	SubIndex	<i>SubIndex</i> on page A-34	00 hex	00 to FF hex	RW		04 hex		04 hex
	Length	<i>Length</i> on page A-34	00 hex	00 to FF hex	RW		05 hex		05 hex
	Data	<i>Data</i> on page A-34	*2	*3	RW		06 hex		06 hex
	Error Code	<i>Error Code</i> on page A-34	0000 hex	0000 to FFFF hex	RO		07 hex		07 hex
	Timeout	<i>Timeout</i> on page A-35	0000 hex	0000 to FFFF hex	RW		10 hex		10 hex
Sequence No	<i>Sequence No</i> on page A-35	00 hex	00 to FF hex	RW	11 hex	11 hex			

*1. "n" indicates the port number.

*2. All of the 232 bytes are 00 hex.

*3. All of the 232 bytes are 00 hex to FF hex.

An explanation of each object is provided below.

● Control

This object controls the writing and reading of the messages that are sent. The meanings of the set values are as follows:

Set value	Meaning
00 hex	No processing
01 hex	Reserved
02 hex	Write
03 hex	Read

● **Status**

This object shows the status of the IO-Link Master Unit or IO-Link device when a sent message is received. The meanings of the values are as follows.

Value	Meaning
00 hex	No operation
01 hex	Busy
02 hex	Successful
03 hex	Reserved
04 hex	Error (IO-Link Master)
05 hex	Error (IO-Link Device)

● **Index**

This object specifies the index number of the object held by the IO-Link device.

● **SubIndex**

This object specifies the subindex number of the object held by the IO-Link device.

● **Length**

This object specifies the size of the data to be written when writing. The unit is bytes.

● **Data**

This object specifies the data to be written when writing.

● **Error Code**

This object indicates the error code when the status value of the subindex 02 hex is 04 hex or 05 hex. The meanings of the error codes are as follows. When the value of status is 02 hex, the meaning is normal end, and the value of error code is 0000 hex.

Status value	Error code value	Error code meaning	Correction
04 hex	4806 hex	The port communications setting is not IO-Link Mode.	Set the port communications setting to IO-Link Mode.
	4807 hex	There is no IO-Link device.	Connect an IO-Link device.
		The I/O power is OFF.	Turn on the I/O power.
		Timeout has occurred.	Change the timeout setting.
	4808 hex	An IO-Link Communications Module Processing Error occurs.	Refer to the Sysmac event code and take the corresponding measure. For details on Sysmac event codes, refer to <i>10-2-3 Sysmac Event Codes and Troubleshooting</i> on page 10-20.
A Device Configuration Verification Error occurs.			
05 hex	<ul style="list-style-type: none"> Upper 1 byte Error code defined in the IO-Link standard Lower 1 byte Additional code defined in the IO-Link standard 	For the meanings of error codes, refer to Table C.1 Error-Types in Annex C of <i>IO-Link Interface and System Specification Version 1.1.2</i> .	Refer to the instruction manuals for the connected IO-Link devices and take the corresponding measure.

- **Timeout**

This object is the time that the IO-Link Master Unit monitors a response from an IO-Link device. The unit is ms. When 0000 hex is specified, monitoring is for 2 s.

- **Sequence No**

This object specifies the sequence number of the message to be sent.



Precautions for Correct Use

This object allows complete access.

However, pay attention to the followings when you read or write the object with complete access.

The followings are reserved and padded in this object.

For the NX-type IO-Link Master Unit

- Two bytes including one byte of number of entries and one byte of padding before the Control object
 - Reserved in 16 bytes between the Error Code object and Timeout object
 - Padded in one byte after the Sequence No object
- The total size of the object will be 262 bytes according to the above contents.

For the GX-type IO-Link Master Unit

- Two bytes including one byte of number of entries and one byte of padding before the Control object
- The total size of the object will be 245 bytes according to the above content.

Precautions are as follows.

When you read the object

Reserve, padding and number of entries are including in the read values.

When you write the object

Specify all write values to 00 hex for the reserve, padding and number of entries.

Controller Processing

The following describes controller processing for access from the controller to an IO-Link device. Create the user program for the controller processing according to the following descriptions.

● Controller Processing Flow Chart

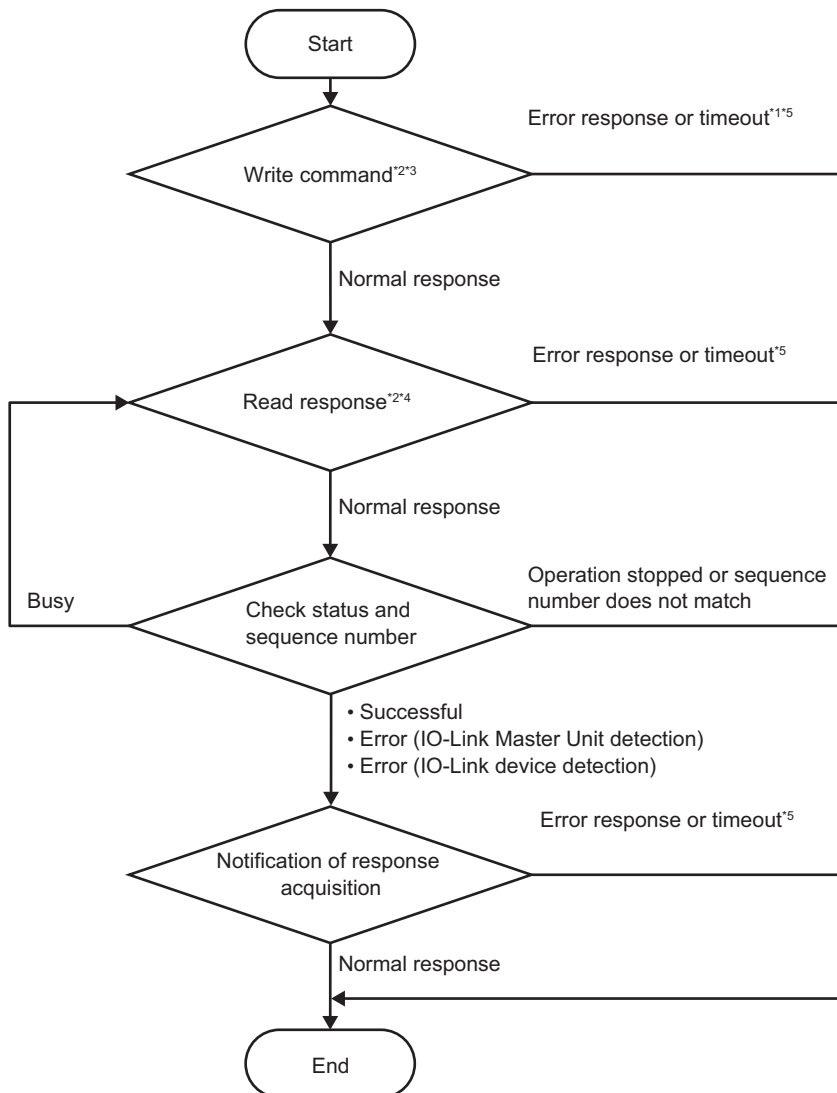

- *1. If the IO-Link Master Unit performs the command write process during message processing, an error response is returned. If that happens, end the process. After ending the process, perform the command write process again.
- *2. If the controller does not support complete access, perform reading or writing for each subindex number.
- *3. If you write for each subindex number, write the Control object last.
- *4. Give an interval after the command writing process before executing the response read process. This allows you to prevent repeating of the read process due to being busy.
- *5. An error response or timeout for the execution of a communications instruction.

● **Controller Processing Procedure**

Step	Controller processing		Commu- nications direc- tion *1	IO-Link Master Unit processing
1.	Write com- mand	<p>Send a command to the object for access- ing an IO-Link device. Specify the following values.</p> <ul style="list-style-type: none"> • Control When writing, the value is 0x02 (Write). When reading, the value is 0x03 (Read). • Status --- • Index Index number of the IO-Link device • SubIndex Subindex number of the IO-Link device • Length When writing, size of the data to be writ- ten • Data When writing, data to be written • Error Code --- • Timeout Response monitoring time • Sequence No When writing, any value in the range of 00 to FF hex 	→	<p>Receive a command, detect that the con- trol value changes from 0x00 (No pro- cessing), and set the status value to 0x01 (Busy). Then, send a message to the IO-Link device.</p> <p>After receiving a response from the IO-Link device, update the following val- ues.</p> <ul style="list-style-type: none"> • Length (when reading) • Data (when writing) • Error Code • Sequence No <p>After updating, change the status value to one of the following.</p> <ul style="list-style-type: none"> • 0x02: Successful • 0x04: Error (IO-Link Master) • 0x05: Error (IO-Link Device)
2.	Read response	<p>When writing was performed in step 1, send a read command to the same address as that in step 1.</p>	←	<p>Send a response to the controller.</p>
3.	Check status and sequence number	<p>Check the status and sequence number of the read data.</p> <p>Send a read command until the status becomes one of the following.</p> <ul style="list-style-type: none"> • 0x02: Successful • 0x04: Error (IO-Link Master) • 0x05: Error (IO-Link Device) <p>When reading, check that the read sequence number matches the sequence number specified in the sent command. If it matches, send a response for the sent command.</p>	←	<p>Send a response to the controller.</p>

Step	Controller processing		Communi- cations direc- tion*1	IO-Link Master Unit processing
4.	Notification of response acquisition	Send a command with the following values specified to notify the IO-Link Master Unit that a response was acquired from the IO-Link Master Unit. <ul style="list-style-type: none"> • Control 00 hex: No processing • Status --- • Index --- • SubIndex --- • Length --- • Data --- • Error Code --- • Timeout --- • Sequence No --- 	→	Receive a command, detect that the control value changes from 0x00 (No processing), and set the status value to 0x00 (No operation).

*1. →: Sending of command from the controller to the IO-Link Master Unit
 ←: Sending of response from the IO-Link Master Unit to the controller

Restrictions

The restrictions are given below.

- Do not perform message communications and access from CX-ConfiguratorFDT at the same time for the IO-Link Master Unit.
- Do not perform message communications to the IO-Link Master Unit when the IO-Link Master Unit is starting.
- Do not turn OFF the power of the IO-Link Master Unit and IO-Link device during the execution of message communications with the IO-Link Master Unit.
- The timing of reflecting the values to be written to an IO-Link device depends on the specifications of the IO-Link device. For details on the reflection timing of IO-Link devices, refer to the instruction manuals for the connected IO-Link devices.

A-4 Precautions When Using the OMRON EtherNet/IP with CX-ConfiguratorFDT

When you use OMRON EtherNet/IP for the CX-ConfiguratorFDT and the CPU Unit or Industrial PC, and communicate with the following connection methods, an online connection may not be established depending on the Windows firewall settings.

- Ethernet I/F
- NJ/NX/NY Series Ethernet Direct I/F
- NJ/NX Series USB Port

In such cases, allow access to the network in a Windows firewall security Dialog Box that is displayed when the CX-ConfiguratorFDT connects to it for the first time, or change the Windows firewall settings to allow communications through the Ethernet port.

Better firewall security for Windows XP (SP2 or higher), Windows Vista, and Windows 7 higher has increased the restrictions for data communications.

The following gives the procedure to make the Windows firewall settings for each OS.



Precautions for Correct Use

The main function of the firewall is to prevent unwanted access from external sources (e.g., the Internet). The changes that are made with the following procedures are to allow the CX-ConfiguratorFDT and the CPU Unit or Industrial PC to connect. If your computer is on an inhouse network, make sure that security will not be jeopardized before you change the settings.

Windows XP

Use the following procedure to change the settings.

- 1** When you attempt to connect to the CPU Unit or Industrial PC from the CX-ConfiguratorFDT, the **Windows Security Warning** Dialog Box is displayed.
- 2** Click the **Allow access** Button.

A USB or EtherNet/IP connection will be approved for the CX-ConfiguratorFDT, and you will be able to connect the CX-ConfiguratorFDT in the future.



Precautions for Correct Use

If you clicked the **Cancel** Button in step 2, a USB connection or EtherNet/IP connect may not be possible. In such case, perform the following procedure.

- (1) Select **Control Panel - Windows Firewall** from the Windows Start menu.
The **Windows Firewall** Dialog Box is displayed.
- (2) Click the **Exceptions** Tab Page in the Windows Firewall Dialog Box, select the **CX-ConfiguratorFDT** Check Box in the **Programs or Services** List.

Windows Vista/Windows 7 or Higher

Use the following procedure to change the settings. Always perform steps 1 to 6 if you cannot go online. The **User Account Control** Dialog Box may be displayed during this procedure. If it appears, click the **Continue** Button and continue with the procedure.

- 1** Select **Control Panel** from the Windows Start Menu and change the display to **Classic View**.
- 2** Open the **Administrative Tools** and select **Windows Firewall with Advanced Security** from the shortcut icon that is displayed.
- 3** Select **Windows Firewall with Advanced Security - Inbound Rules** on the left side of the **Windows Firewall with Advanced Security** Dialog Box.

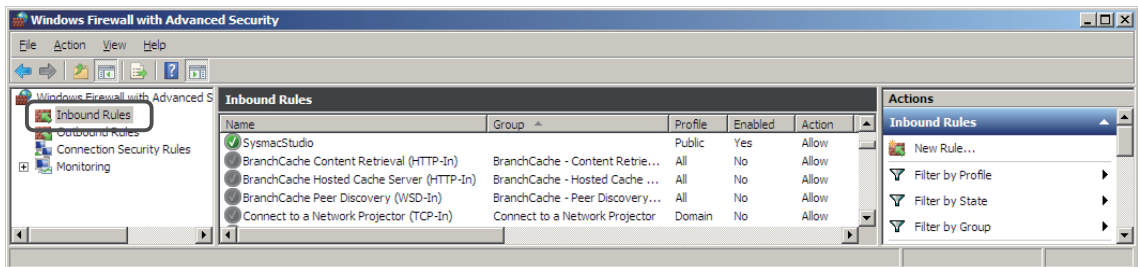

- 4** Select **New Rule** under **Inbound Rules** in the **Actions** Area on the right side of the dialog box.

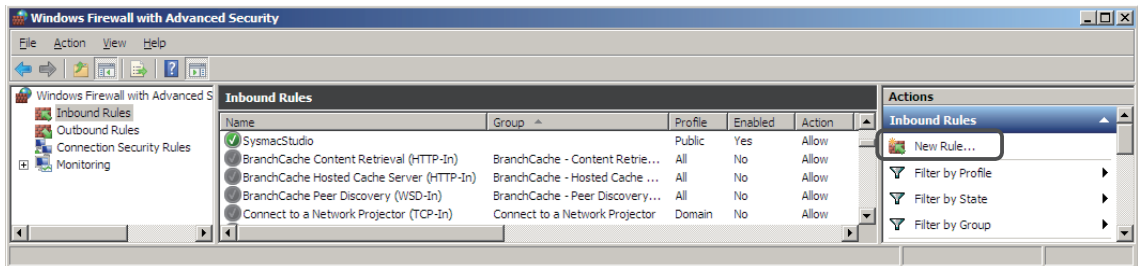

- 5** Make the following settings for each step in the **New Inbound Rule Wizard** Dialog Box, and click the **Next** Button to move between steps.

Rule Type	Select Custom .
Program	Select All Programs .
Protocol and support	Select ICMPv4 as the protocol type. Protocol type: <input type="text" value="ICMPv4"/> Protocol number: <input type="text" value="1"/>
Scope	Select Any IP address for everything.
Action	Select Allow the connection .
Profile	Select Domain, Private, and Public .
Name	Enter any name, e.g., Omron_EIP.

- 6 Click the **Finish** Button. The rule that you defined will be registered in the **Inbound Rules** (e.g., Omron_EIP).

Close the **Windows Firewall with Advanced Security** Dialog Box.

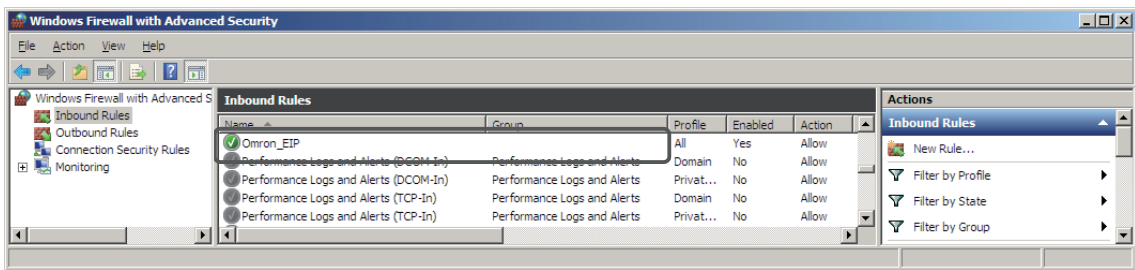

- 7 When you attempt to connect to the NJ/NX-series CPU Unit from the CX-ConfiguratorFDT, the **Windows Security Warning** Dialog Box is displayed.

- 8 Click the **Allow access** Button.

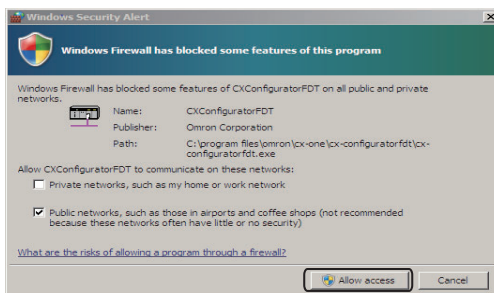

(Windows 7)

A USB or EtherNet/IP connection will be approved for the CX-ConfiguratorFDT, and you will be able to connect the Network Configurator in the future.

Precautions for Correct Use

If you clicked the **Cancel** Button in step 8, a USB connection or EtherNet/IP connect may not be possible. In such case, perform the following procedure.

- (1) Select **Control Panel - Windows Firewall** from the Windows Start Menu.
The **Windows Firewall with Advanced Security** Dialog Box is displayed.
- (2) Select **Turn Windows Firewall on or off**.
The **Customize settings** for each type of network is displayed.
- (3) Clear the selection in the *Block all incoming connection, including those in that list of allowed programs* Check Box, and click the **OK** Button.
- (4) Select the **Advanced settings** from the Windows Firewall.
The **Windows Firewall with Advanced Security** is displayed.
- (5) Select **Inbound Rules** and double-click **CXConfiguratorFDT** from the Inbound Rules List.
The **CXConfiguratorFDT Properties** Dialog Box is displayed.
- (6) Make the following settings in the **General** Tab Page under the **CXConfiguratorFDT Properties** Dialog Box.
General: Select **Enabled**.
Action: Select **Allow the connection**.



Index



Index

A

AL status 10-10
 automatic baud rate setting
 for IO-Link communications 1-21

B

backing up and restoring 10-50
 parameter settings in IO-Link Master Units 10-49
 backing up settings 7-15
 backup and restoration of parameter settings
 in IO-Link devices 1-22, 7-14
 backup setting 3-4, 7-19
 Baud rate 1-12

C

C indicator (NX-type) 2-2
 C/E indicator (GX-type) 2-2
 C/Q indicator 2-3
 clear backup data command 5-5, 7-23
 clearing backup data 7-21
 communications distance 1-12
 communications media 1-12
 communications mode 25
 communications mode settings 1-21, 7-2
 communications modes and IO-Link wiring 2-5
 communications specifications 1-12
 compliant standards 1-12
 connected device verification 1-21, 7-6
 current error 10-18
 CX-ConfiguratorFDT 1-12, 8-14
 CX-ConfiguratorFDT procedures 8-14
 cyclic communications 25, 1-4, 1-21, 6-5
 communications with controller 6-5
 IO-Link communications 6-5
 starting 6-6
 stopping 6-7
 writing a program 6-6

D

detection of short-circuits in I/O cables 1-22
 device 25
 device configuration verification error 25, 4-10
 Device configuration verification error (for GX-type) .. 10-40
 device configuration verification error (for NX-type) ... 10-31
 device event 25
 error-level device event 25
 warning-level device event 27
 device event (for GX-type) 10-45
 device event (for NX-type) 10-34, 10-35
 device event flag 4-8, 4-11

device I/O size error 25, 4-11
 device I/O size error flag 4-8
 digital input 25
 digital input collection 1-22, 7-25
 digital input collection setting 3-5
 digital input data 25, 4-13
 digital input filter 1-22, 7-13
 digital input Filter setting 3-5
 digital inputs for Pin 2 7-4
 digital inputs for pin 2 25, 1-4, 1-21
 digital output 25
 digital output data 25, 4-15
 digital signal inputs 1-4
 digital signal outputs 1-4
 disable port 7-3
 disconnected operation 6-7
 DTM (Device Type Managers) 8-14

E

E indicator (NX-type) 2-2
 edit backup parameter settings 8-7
 edit PDO mapping settings 8-10
 emergency messages 10-8
 error status for ports 4-8
 ESI (EtherCAT Slave Information) files 1-13
 EtherCAT cables for GX-type A-24
 event codes and troubleshooting 10-20
 event log 1-22
 extension cables from sensors with M12 plugs A-26

G

GX-ILM08C 1-12

H

host communications 6-2
 types 1-7

I

I/O allocation settings 4-17
 I/O cable short-circuit 4-10
 I/O cable short-circuit (for GX-type) 10-41
 I/O cable short-circuit (for NX-type) 10-31
 I/O cables for GX-type IO-Link Master Units A-25
 I/O data 25, 4-2
 I/O port status 4-7
 I/O Power On/Off Status 4-7, 4-10
 I/O power supply 2-10
 I/O power supply ON detected (for GX-type) 10-46
 I/O short detected flag 4-8
 I/O-Link communications error flag 4-8

I/O-Link event code26
 indicators 2-2, 10-12
 input data enabled flag25
 input data enabled flags4-10
 input filter setting7-13
 IODD (IO Device Description) files1-13
 IO-Link 1-2, 1-5
 introduction to IO-Link systems1-4
 IO-Link Communications6-4
 IO-Link communications 1-4, 6-4
 IO-Link communications cycle time25
 IO-Link communications error25, 4-10
 IO-Link communications error (for GX-type)10-44
 IO-Link communications error (for NX-type)10-35
 IO-Link communications error detection1-22
 IO-Link communications module processing error
 4-7, 4-10
 IO-Link communications module processing error
 (for GX-type)10-42
 IO-Link communications module processing error
 (for NX-type)10-32
 IO-Link communications specifications1-12
 IO-Link device26
 IO-Link device configuration information created
 (for GX-type)10-45
 IO-Link device configuration information created
 (for NX-type)10-36
 IO-Link device configuration settings 26, 3-4, 7-8
 IO-Link device information area26, 5-4
 IO-Link device verification setting 26, 3-3, 7-8
 IO-Link devices1-3
 IO-Link input data26
 IO-Link master26, 1-3
 IO-Link mode26, 7-2
 IO-Link output data26
 IO-Link total communications lost frames 26, 1-22, 7-11
 IO-Link Wiring2-8
 IO-Link wiring 2-5, 2-6

L

load rejection during host communications error
 26, 1-22, 7-9
 load rejection output setting7-10
 load rejection output setting for host communications
 errors3-4
 lost frames (IO-Link total communications lost frames)
 5-3, 7-12

M

M8 Socket/M12 plug A-25
 master control communications mode setting7-4
 message communications 26, 1-4, 1-21, 6-8

N

notification of input data validity1-22
 NX-ILM4001-12

NX-IO Configurator1-12, 8-13
 NX-IO Configurator Procedures8-13

O

object26
 OD26
 offset setting of digital input collection3-5

P

parameters3-2, 8-7
 part names and functions2-2
 PDO mapping error27
 PDO mapping error flag4-8, 4-11
 pin 2 digital input data27
 port27
 port error status25
 power supply cables for GX-type A-25
 process data27
 process input data25
 process input data from IO-Link devices4-14
 process output data26
 process output data to IO-Link devices4-16

R

replacement method for IO-Link devices10-52
 restoration setting3-4, 7-20
 restoring settings7-20

S

SIO27
 SIO (DI) mode27, 7-2
 SIO (DO) mode27, 7-2
 startup procedures1-24
 status or software switches other than for I/O data5-2
 Sysmac error status4-11, 4-12
 Sysmac Studio1-12
 system configurations1-7
 controller communications with EtherCAT1-8, A-2
 controller communications with EtherNet/IP
 1-10, A-10, A-16
 controller communications with NX bus1-10

T

terminals2-3

U

Unit power supply and I/O power supply2-9, 2-11

W

wiring output devices2-8
 wiring three-wire sensors2-6

wiring two-wire sensors 2-7

X

XS3W-M42C-4C2-A A-25
XS5F-D421 A-25
XS5W-D421 A-26
XS5W-T421 A-24

OMRON Corporation Industrial Automation Company
Kyoto, JAPAN

Contact: www.ia.omron.com

Regional Headquarters

OMRON EUROPE B.V.

Wegalaan 67-69, 2132 JD Hoofddorp
The Netherlands
Tel: (31)2356-81-300/Fax: (31)2356-81-388

OMRON ASIA PACIFIC PTE. LTD.

No. 438A Alexandra Road # 05-05/08 (Lobby 2),
Alexandra Technopark,
Singapore 119967
Tel: (65) 6835-3011/Fax: (65) 6835-2711

OMRON ELECTRONICS LLC

2895 Greenspoint Parkway, Suite 200
Hoffman Estates, IL 60169 U.S.A.
Tel: (1) 847-843-7900/Fax: (1) 847-843-7787

OMRON (CHINA) CO., LTD.

Room 2211, Bank of China Tower,
200 Yin Cheng Zhong Road,
PuDong New Area, Shanghai, 200120, China
Tel: (86) 21-5037-2222/Fax: (86) 21-5037-2200

Authorized Distributor:

© OMRON Corporation 2016-2018 All Rights Reserved.
In the interest of product improvement,
specifications are subject to change without notice.

Cat. No. W570-E1-05

0418