

# USER MANUAL

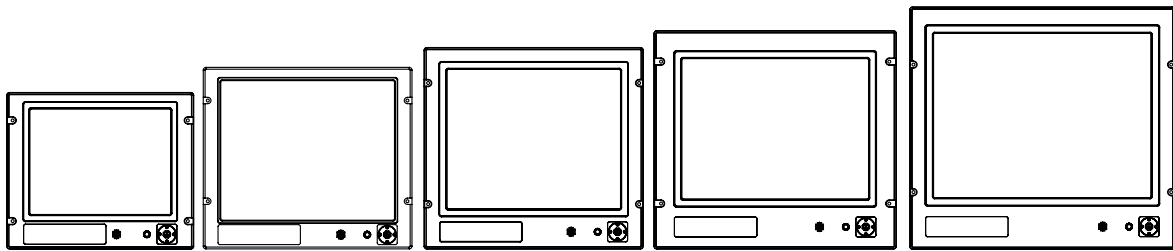

## Series 1 G2 - Maritime Multi Display Models

- JH 15T17 MMD-xRx-xxxx - 15.0 inch Maritime Multi Display
- JH 19T14 MMD-xRx-Sxxx - 19.0 inch Maritime Multi Display (Slim Frame)
- JH 19T14 MMD-xRx-xxxx - 19.0 inch Maritime Multi Display
- JH 20T17 MMD-xRx-xxxx - 20.1 inch Maritime Multi Display
- JH 23T14 MMD-xRx-xxxx - 23.1 inch Maritime Multi Display

User Manual MMD Series 1 G2	
Updated: 28 Jun 2021	Doc Id: INB10036-4 (Rev 02)
Created: 363	Approved: 6987

Copyright © 2021 Hatteland Technology AS  
Eikeskogvegen 52, N-5570 Aksdal, Norway.

All rights are reserved by Hatteland Technology AS. This information may not, in whole or in part, be copied, photocopied, reproduced, translated or reduced to any electronic medium or machine-readable form without the prior written consent of Hatteland Technology AS. Review also: [www.hattelandtechnology.com/hubfs/pdf/misc/doc100703-1\\_permission\\_to\\_create\\_user\\_manuals.pdf](http://www.hattelandtechnology.com/hubfs/pdf/misc/doc100703-1_permission_to_create_user_manuals.pdf)

The products described, or referenced, herein are copyrighted to the respective owners.  
The products may not be copied or duplicated in any way. This documentation contains proprietary information that is not to be disclosed to persons outside the user's company without prior written consent of Hatteland Technology AS.

The copyright notice appearing above is included to provide statutory protection in the event of unauthorized or unintentional public disclosure.

**All other product names or trademarks are properties of their respective owners !**

WARNING: This is a class A product. In a domestic environment this product may cause radio interference in which case the user may be required to take adequate measures.

Statement above last revised 31 Jul. 2019

# Contents

<b>Contents .....</b>	<b>3</b>
Contents of package.....	6
<b>General .....</b>	<b>7</b>
IEC62368 policy - Introduction .....	8
About this manual.....	9
About Hatteland Technology.....	9
www.hattelandtechnology.com .....	9
Contact Information .....	9
Maritime Multi Display (MMD) - Introduction .....	10
Product Labeling.....	11
<i>Front Logo Label</i> .....	14
Touch Screen products.....	15
<i>Introduction to products with Touch Screen</i> .....	15
<i>Touch Screen Drivers and Documentation</i> .....	16
<b>Installation.....</b>	<b>17</b>
General Installation Recommendations.....	18
Installation and mounting.....	18
Ergonomics.....	20
Cables .....	20
<i>Cable Entries &amp; Connectors (Marked area) - Illustration only (19 inch used as example)</i> .....	20
Housing / Terminal Block Connector Overview .....	21
Rotary Bracket and Mounting Bracket (15 inch) combined assembling.....	23
Rotary Bracket and Mounting Bracket - assembling/finalization .....	24
Physical Connections .....	26
<b>Operation.....</b>	<b>31</b>
User Controls.....	32
Status LED Overview .....	34
For ECDIS Calibrated Products.....	34
On Screen Display (OSD) Menu Introduction.....	35
OSD Key Code (password) overview .....	35
OSD Keycode / OSD Lock Mode .....	36
OSD “Basic”, “Advanced” & “Service” Menu modes.....	37
OSD Visual Feedback (examples) .....	37
OSD Menu Structure .....	38
<i>Input Source Settings</i> .....	38
<i>Image Settings</i> .....	38
<i>Color Mode Settings</i> .....	39
<i>Multi-PIP Settings</i> .....	39
<i>OSD Miscellaneous</i> .....	40
<i>Management Settings</i> .....	41
<i>Service Settings</i> .....	42
On Screen Display (OSD) Menu Functions.....	43

# Contents

<b>Specifications .....</b>	<b>69</b>
Specifications - JH 15T17 MMD-xRx-xxxx .....	70
Specifications - JH 19T14 MMD-xRx-Sxxx (Slim Frame Model) .....	71
Specifications - JH 19T14 MMD-xRx-xxxx .....	72
Specifications - JH 20T17 MMD-xRx-xxxx .....	73
Specifications - JH 23T14 MMD-xRx-xxxx .....	74
<b>Technical Drawings .....</b>	<b>75</b>
Technical Drawings - JH 15T17 MMD-xRx-xxxx .....	76
Technical Drawings - JH 15T17 MMD-xRx-xxxx .....	77
Technical Drawings - JH 19T14 MMD-xRx-Sxxx .....	78
Technical Drawings - JH 19T14 MMD-xRx-xxxx .....	79
Technical Drawings - JH 20T17 MMD-xRx-xxxx .....	80
Technical Drawings - JH 23T14 MMD-xRx-xxxx .....	81
<b>Technical Drawings - Accessories .....</b>	<b>83</b>
Technical Drawings - JH 15TSV STD-A1 .....	84
<i>Sun Visor - 15"</i> .....	84
Technical Drawings - JH 19TSV STD-B1 .....	85
<i>Sun Visor - 19" Slim Frame</i> .....	85
Technical Drawings - JH 19TSV STD-A1 .....	86
<i>Sun Visor - 19"</i> .....	86
Technical Drawings - JH 20TSV STD-B1 .....	87
<i>Sun Visor - 20"</i> .....	87
Technical Drawings - JH 23TSV STD-A1 .....	88
<i>Sun Visor - 23"</i> .....	88
Technical Drawings - JH 15TRO STD-A1 .....	89
<i>Rotary Bracket - 15"</i> .....	89
Technical Drawings - JH MMDRO STD-A1 .....	90
<i>Rotary Bracket - 17" to 26"</i> .....	90
Technical Drawings - JH 15TBR STD-B1 .....	91
<i>Mounting Bracket - 15"</i> .....	91
Technical Drawings - JH MMDBR STD-A1 .....	92
<i>Mounting Bracket - 17" to 20"</i> .....	92
Technical Drawings - JH 19TBR STD-B1 .....	93
<i>Mounting Bracket - 19" Slim Frame</i> .....	93
Technical Drawings - JH 19BRD STD-A1 .....	94
<i>EN60945 Mounting Bracket - 19"</i> .....	94
Technical Drawings - JH 23TBR T01-A1 .....	95
<i>Mounting Bracket - 23"</i> .....	95
Technical Drawings - JH 23BRD STD-A1 .....	96
<i>EN60945 Mounting Bracket - 23"</i> .....	96
Technical Drawings - JH 15TAP STD-A1 .....	97
<i>19" Rack Adapter - 15" TFT</i> .....	97















# Contents

Technical Drawings - JH 15TAP STD-B1.....	98
<i>CRT Adapter - 15" TFT to 17"</i> .....	98
Technical Drawings - JH 17TAP STD-A1.....	99
<i>17" TFT to 19" Rack Adapter</i> .....	99
Technical Drawings - JH 19TAP STD-A1.....	100
<i>CRT Adapter - 19" TFT to 21"</i> .....	100
Technical Drawings - JH 19TAP STD-A2.....	101
<i>CRT Adapter - 19" TFT to 20" TFT</i> .....	101
Technical Drawings - JH 19TAP STD-B1.....	102
<i>CRT Adapter (Custom) - 19" TFT to 21"</i> .....	102
Technical Drawings - JH 15VED STD-A1 .....	103
<i>VESA Adapter - 15"</i> .....	103
Technical Drawings - JH 19VED STD-A1.....	104
<i>VESA Adapter - 19"</i> .....	104
Technical Drawings - JH 19VED STD-B1 .....	105
<i>VESA Adapter - 19" Slim Frame</i> .....	105
Technical Drawings - JH 20VED STD-A1 .....	106
<i>VESA Adapter - 20"</i> .....	106
Technical Drawings - JH 23VED STD-A1 .....	107
<i>VESA Adapter - 23"</i> .....	107
Technical Drawings - JH 15TWC STD-A1 .....	108
<i>Water Cover - 15"</i> .....	108
Technical Drawings - JH 19TWC STD-B1 .....	109
<i>Water Cover (HW01) - 19"</i> .....	109
Technical Drawings - JH 19TWC STD-C1 .....	110
<i>Water Cover - 19" Slim Frame</i> .....	110
Technical Drawings - JH 20TWC STD-B1 .....	111
<i>Water Cover - 20"</i> .....	111
Technical Drawings - JH 23TWC STD-A1 .....	112
<i>Water Cover - 23"</i> .....	112

## Appendixes ..... 113

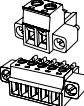
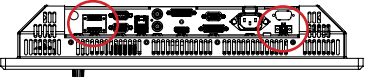
Pinout Assignments .....	114
IEC62368 policy for Hatteland Technology products .....	117
Basic Trouble-shooting .....	119
Declaration of Conformity .....	120
Return Of Goods Information .....	121
General Terms and Conditions .....	122
Pixel Defect Policy .....	123
Parts and Recycling.....	124
Notes .....	125
Revision History.....	126

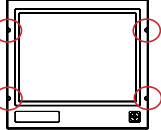
# Contents of package

Item	Description	Illustration
 HA-SDM-2M	1 pcs of Standard DVI Signal Cable. DVI-D 18+1P Male to DVI-D 18+1P Male Single Link - Length 2.0m	
 HA-VGA-2M-32	1 pcs of Standard VGA Signal Cable. DSUB 15P Male to DSUB 15P Male - Length 2.0m	
 TP52/TC01-1,8M	1 pcs of power cable European Type F "Schuko" to IEC. Length 1.8m  <i>Note: Included in package for models with AC input.</i>	EUR TYPE F 
 TP11/TC01-1,8M	1 pcs of power cable US Type B plug to IEC. Length 1.8m  <i>Note: Included in package for models with AC input.</i>	US TYPE B 
 DVI-4	1 x DVI-I > RGB/VGA adapter DVI-I 12+5P (Single Link) Male to DSUB 15P Female	
 Terminal Block Connector Kit	Terminal Block Connector Kit as follows (may in some cases be already factory mounted): 1 x 2-pin Terminal Block 5.08 for DC Power In 2 x 5-pin Terminal Block 3.81 for RS-422 / RS-485 / SCOM / Buzzer Module  Refer to "Configuring Housing / Terminal Block Connector" section for usage.	  Note: Location of module(s) may differ between unit sizes
 1P06025 (screw) & 16M06012150 (washer)	4 pcs of M6X25 pan screws. Suitable for securing the display unit into a console cut-out. See illustration to the right.  <b>DO NOT USE THESE TO MOUNT BRACKETS ONTO THE UNIT.</b> Use the provided and dedicated screws for accessories (see next table below)	
	Test Report	

## Package may also include:

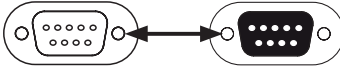
Item	Description	Illustration
 EK131.2	1 pcs of Standard RS-232 Serial Extension Cable DB9M-DB9F - Length: 200cm  <i>Note: This cable is only included with a product with factory mounted touchscreen.</i>	





# General

# IEC62368 policy - Introduction

## Safety Instructions

Please read and understand the material in the manual in its entirety before doing any installation/servicing/upgrades. Personnel who are allowed to do work on the unit is detailed in the “**IEC62368 policy for Hatteland Technology product**” section later in this manual. Symbols pertaining to different personnel in regard to operations is described in the user manual.

### Based on requirements EN 62368-1:2014 and IEC 62368-1:2018

Authority	Description
<b>Children</b> 	This equipment is not suitable for use in locations where children are likely to be present.
<b>Ordinary person/ Sailor/End-User</b> 	Not allowed to open unit. Not allowed to install the unit. Not allowed to terminate/connect cables to the unit.
<b>Instructed person</b> 	Allowed to open hatches/latches which does not require tools, such as Disktrays. Allowed to open "battery-hatch" to change the battery even if tools are required. Allowed to install the unit. Allowed to terminate/connect cables to the unit indoors.
<b>Skilled person</b> 	Allowed to open and disassemble the unit.  Allowed to install the unit. Allowed to terminate/connect cables to the unit indoors and outdoors. Allowed to terminate/connect earth/ground wire.  Note: Be aware that additional definition for “skilled person” may apply, country dependent.

## About this manual

The manual contains electrical, mechanical and input/output signal specifications. All specifications in this manual, due to manufacturing, new revisions and approvals, are subject to change without notice. However, the last updated and revision date of this manual are shown both on the frontpage and also in the "Revision History" chapter. This user manual is a standard/general manual that applies to all variations of its product family, i.e. deviation from actual configuration may exist.

## About Hatteland Technology

Hatteland Technology is the leading technology provider of specialized display and computer products, delivering high quality, unique and customized solutions to the international maritime, naval and industrial markets.

The company represents innovation and quality to the system integrators worldwide. Effective quality assurance and investment in sophisticated in-house manufacturing methods and facilities enable us to deliver Type Approved and Mil tested products. Our customer-oriented approach, technical knowledge and dedication to R&D, makes us a trusted and preferred supplier of approved solutions, which are backed up by a strong service network.

## www.hattelandtechnology.com

You will find our website full of useful information to help you make an informed choice as to the right product for your needs. You will find detailed product descriptions and specifications for the entire range on Displays, Computers and Panel Computers, Military solutions as well as the range of supporting accessories. The site carries a wealth of information regarding our product testing and approvals in addition to company contact information for our various offices around the world, the global service locations and the technical help desk, all ensuring the best possible support wherever you, or your vessel, may be in the world.

## Contact Information

<p><b>Head office, Aksdal / Norway:</b> Hatteland Technology AS Eikeskogvegen 52 N-5570 Aksdal, Norway</p> <p>Switchboard: Tel: +47 4814 2200 mail@hattelandtechnology.com</p>	<p><b>Sales office, Frankfurt / Germany:</b> Hatteland Technology GmbH Werner Heisenberg Strasse 12, D-63263 Neu-Isenburg, Germany</p> <p>Uwe Scheumann: Tel: +45 2463 9565</p> <p>Elke Freisens: Tel: +49 173 6174753</p>
<p><b>Sales office, Oslo / Norway:</b> Hatteland Technology AS Strandveien 35 N-1366 Lysaker Norway</p> <p>Switchboard: Tel: +47 4814 2200 mail@hattelandtechnology.com</p>	<p><b>Sales office, Aix-en-Provence / France:</b> Hatteland Technology SAS Actimart- 1140, rue Ampère, CS 80544 13594 Aix-en-Provence, Cedex 3 France</p> <p>Mehdi Bounoua (Sales Director Europe, Middle East &amp; Africa): Tel : +33 6 88 33 64 93</p>
<p><b>Sales office, Vista / USA:</b> Hatteland Technology Inc 450 South Melrose Drive, Suite #107 Vista, CA 92081 USA</p> <p>Donna Pallonetti: Tel: +1 858-282-0659 Fax: +1 858-408-1834</p>	

For an up-2-date list, please visit <https://www.hattelandtechnology.com/contact>

# Displays Series 1 - Generation 2

## Maritime Multi Display (MMD) - Introduction

The Series 1 Generation 2 (G2) Maritime Multi Display (MMD) models are delivered with Multi-power (AC and DC built in) ensuring that they are compatible with all power systems on vessels. The displays will automatically switch to whatever power is connected, making it highly flexible for shipbuilders and system integrators alike. The onboard connections include DVI-I, DP, Composite Video, as well as VGA out, RS-232 for touch, RS-422/485, USB Type A for SCOM, SCOM Ethernet and Potmeter/user connection for access to display settings.

The Series 1 Generation 2 (G2) MMD models are available in a wide range of display size and format, making them suitable for a multitude of shipboard applications, where combining data and video inputs to a single unit provides maximum flexibility. Be it for ship navigation, automation or safety and security, this range with all its possible options provides a robust and versatile platform from which to display and manage multisource data from all of a vessels systems.

The Series 1 Generation 2 (G2) Maritime Multi Display (MMD) feature control buttons on the front of the monitor (keypad control) as well as an potentiometer knob, providing fast and easy user access to the displays OSD features and settings. An Keypad Control only (no potmeter) model is also available.

## A updated generation of innovative, rugged marine displays.....

- TYPE APPROVED
- ECDIS COMPLIANT
- NEW CONNECTIVITY
- NEW FUNCTIONALITY
- FORM, FIT AND FUNCTION
- SUPERIOR BONDING TECHNOLOGY

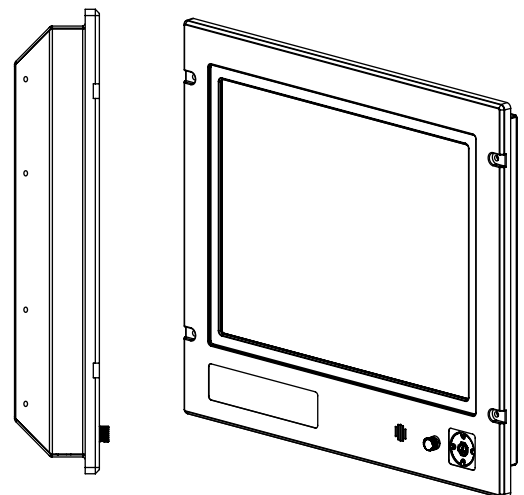
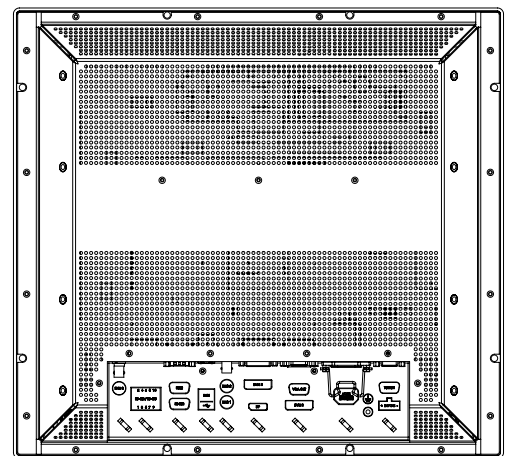
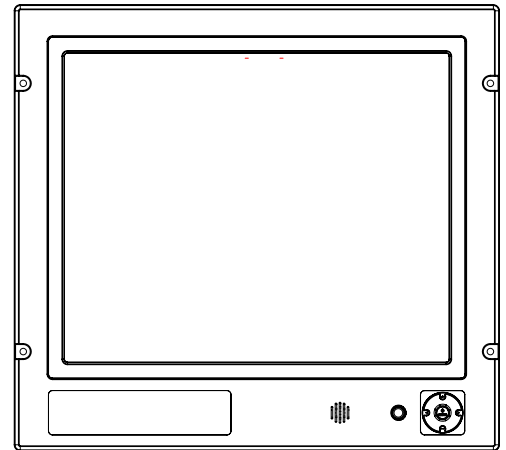





# Product Labeling

## Introduction

This section details the locations, content details and specifications for factory mounted labels for all currently available standard Hatteland Technology Maritime Multi Display (MMD) - Series 1 Generation 2 models. This information will in most cases also apply for most Customized Models as well, but may differ based on customer requirements, in that case, please refer to the customized User Manual (paper or electronic version, dependent on customer requirements).

## Label Size and Types

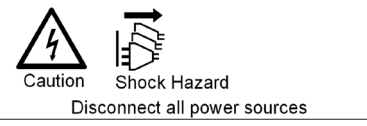
ID	Label Layout	Description	Specification
1		<p><b>Type</b> : Serial Number Label  <b>Name</b> : Label B  <b>Size</b> : 60mm wide x 20mm high (rectangle size)                      Note: Text content of label will match specifications derived from Data Sheet.</p> <p><b>Barcode type:</b> CODE128 (used extensively world wide in shipping and packaging industries. The symbology was formerly defined as ISO/IEC 15417:2007.)</p>	Silver with glue on back, non-tearable and made for thermal transfer printing.
3		<p><b>Type</b> : Touch Screen Label  <b>Name</b> : Label B  <b>Size</b> : 60mm wide x 20mm high (rectangle size)                      Note: Only present if Touch Screen was part of factory option order.</p> <p><b>Note:</b> Content on label will vary based on Touch Screen type and/or Touch Screen Controller. Label shown is for illustration purposes only!</p>	Silver with glue on back, non-tearable and made for thermal transfer printing.
4		<p><b>Type</b> : Warranty Label  <b>Size</b> : 30mm wide x 23mm high (oval size)</p>	Tamper-proof sticker with glue on back.
5		<p><b>Type</b> : Quality Control (QC) Label  <b>Size</b> : 30mm wide x 23mm high (oval size)</p>	FLEXcon@PHARMcal®V 400 F WhiteTC-848V-23 TRACrite™150
7		<p><b>Type</b> : Handling Symbols Label  <b>Size</b> : 16mm wide x 8mm high (rectangle size)                      Symbols indicate Cadmium Free product and proper waste handling required.</p>	FLEXcon@PHARMcal®V 400 F WhiteTC-848V-23 TRACrite™150
8		<p><b>Type</b> : Shock Hazard Caution Label  <b>Name</b> : Label B  <b>Size</b> : 60mm wide x 20mm high (rectangle size)</p> <p>Rules specified in IEC62368-1:2018 chapter 5.7.6. Applies for units with Dual/Multi-Power inputs only (more than 1 Power Input).</p>	Silver with glue on back, non-tearable and made for thermal transfer printing.

## Label Locations

Number ID and coloring based on “Label Size and Types” table from previous page. All illustrations below are seen

Please note that typenumber shown above is a generic sample only. May not reflect products mentioned in this manual. Please review actual product S/N label.

# Product Labeling

from rear (and side where needed) with connectors facing down. Actual labels regarding its size and text orientation vs product size is drawn in. Due to space restrictions on selected units, some labels will be rotated 90 degrees to fit properly. The arrangement of labels may be shifted/stacked differently as it is based on factory options, such as; Touch Screen, but they will be grouped together where possible.

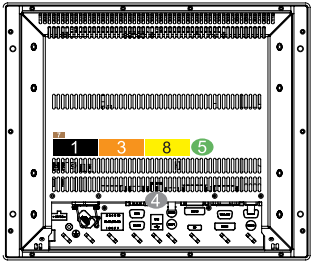
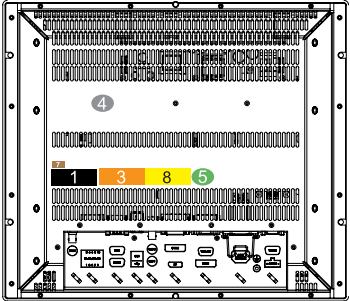
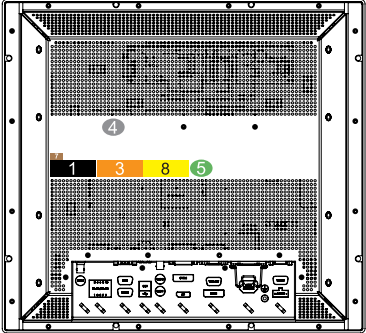
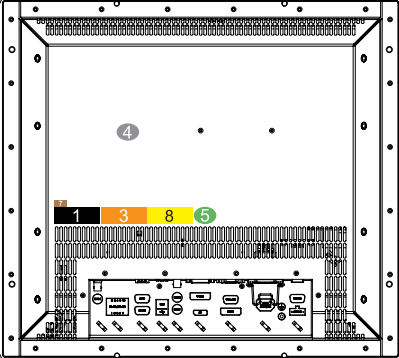
Label Positions	Notes	Applies for Product Range
	<p>Warranty label covers screw and are bent over edge onto terminal connector plate (due to space restrictions). Labels placed on rear.</p>	<p><b>JH 15T17 MMD-xRx-xxxx</b></p>
	<p>Warranty label covers screw. Labels placed on rear.</p>	<p><b>JH 19T14 MMD-xRx-Sxxx</b> (Slim frame)</p>
	<p>Warranty label covers screw. Labels placed on rear.</p>	<p><b>JH 19T14 MMD-xRx-xxxx</b></p>
	<p>Warranty label covers screw. Labels placed on rear.</p>	<p><b>JH 20T17 MMD-xRx-xxxx</b></p>

# Product Labeling

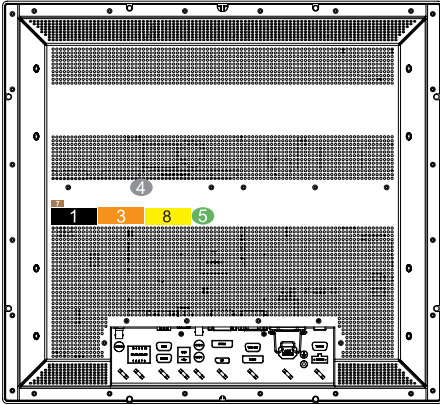

Warranty label covers screw.  
Labels placed on rear.

**JH 23T14 MMD-xRx-xxxx**

# Product Labeling

## Warranty Label

If you are to perform service on a unit still under warranty, any warranty will be void if this label show signs of removal attempts or damaged by screw driver. This label is located on the back of the product and covers a key screw. This is to aid service departments in determining if there has been any unauthorized service on a unit still under warranty.

## Quality Control (QC) Label

This label indicates that the unit is produced, tested and packed according to the manufacture's QA specifications. It will include a Personal ID and signature by the personnel responsible for approving the unit in production, testing and warehouse departments.

## Handling Symbols Label

Ecodesign Requirements for Electronic Displays. The European Union published the Regulation 2019/2021 with specific environmental ecodesign requirements for various types of electronic displays, such as TVs, monitors, and digital signage displays.

Reference: <https://www.enviropass.ca/2021/03/01/5-ecodesign-requirements-for-electronic-displays/>

## Serial Number Label Layout (example)



Please note that typenumber shown above is a generic sample only. May not reflect products mentioned in this manual. Please review actual product S/N label.

## Front Logo Label

The front frame bezel design offers an area for customized logo label. These labels can be ordered and customized with your own logo delivered from us The measurements are as follows.

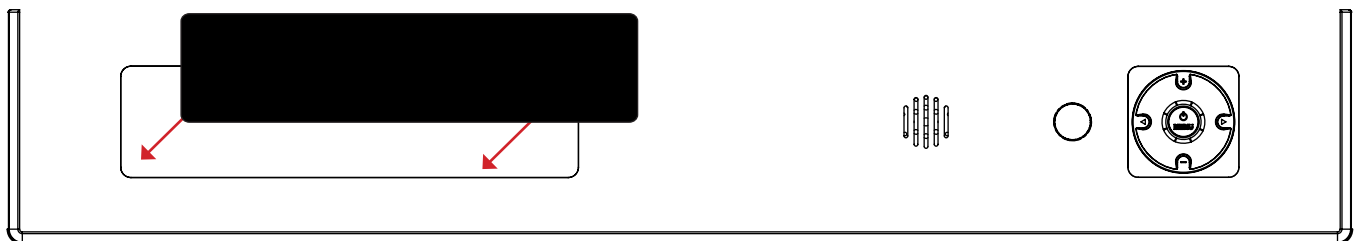

WxH = 181.66 x 44.16mm / 7.15" x 1.74". R4.10 - 4 places in each corner. Depth of area is 0.5mm.

# Touch Screen products

## Introduction to products with Touch Screen

Both Resistive and Capacitive touch screen solutions are used for our products. Please review specifications found in this manual or our website to find your exact type number and then determine if it uses Resistive or Capacitive.

### Capacitive Touch screen

The glass overlay has a coating that stores the charge deposited over its surface electrically. It will not operate with either a gloved hand or with a mechanical stylus. Capacitive touch screens operate by applying a small amount of voltage to each corner of the touch screen. When the screen is touched by a human finger it draws a minute amount of current to the X,Y point of contact. This location is calculated by the touch screen controller and transmitted back to the computer connected to the touch screen controller.

### CAPACITIVE - Brief Specifications

Subject	Details
Construction	<b>Top:</b> ClearTek protective overcoat protects the sensors and increase durability. <b>Inside:</b> Electrode X/Y grid pattern and conductive coating. <b>Bottom:</b> Glass and conductive coating. Small amount of voltage is applied to the four corners for measuring X and Y coordinates of the touch point.
Positional Accuracy	Reported touch coordinates are within 1.0% of true position. (Based on viewing area dimensions)
Touch Contact Requirements	3 ms for finger input.
Endurance Tested	More than 225 million touches in one location without noticeable degradation to the surface.
Cleaning	Water, isopropyl, alcohol, and similar non-abrasive cleaners.
Liquid Resistance	Liquids on screen does not impede touchscreen performance.
Light Transmission	Up to 88% at 550 nm; dependant on specific surface finish chosen.

### Resistive Touch screen

It generally uses a display overlay composed of layers, each with a conductive coating on the interior surface. Special separator "dots" are distributed evenly across the active area and separate the conductive interior layers. The pressure from using either a mechanical stylus or finger produces an internal electrical contact at the "action point" which supplies the controller with vertical and horizontal analog voltages for data input. The resistive touch screens are anti-glare to reduce reflective shine intensity, which will slightly diffuse the light output throughout the screen. Resistive technology activation can be initiated by; a gloved hand, fingernail, mechanical stylus or an ungloved finger.

### RESISTIVE - Brief Specifications

Subject	Details
Construction	<b>Top:</b> Polyester with outside hard-surface coating with clear or anti-glare finish. <b>Inside:</b> Transparent conductive coating. <b>Bottom:</b> Glass substrate with uniform conductive coating. Top and bottom layers separated by separator dots.
Positional Accuracy	Standard deviation of error is less than +/- 0.080-inch (2mm).
Touch Activation Force	Typically 57 to 133 g
Expected Life Performance	More than 35 million touches in one location without failure, using a stylus similar to a finger.
Cleaning	Water, isopropyl, alcohol, and similar non-abrasive cleaners.
Chemical Resistance (Exposed for one hour)	Acetone, Common food and beverages, Hexane, Isopropyl alcohol, Methylene chloride, Methyl ethyl ketone, Mineral spirits, Turpentine
Light Transmission	Typically 75% over visible light spectrum.

# Touch Screen products

## Touch Screen Drivers and Documentation

For products manufactured and delivered with Touch Screen, suitable drivers are available on our website:  
[https://www.hattelandtechnology.com/Series1\\_MMD\\_G2](https://www.hattelandtechnology.com/Series1_MMD_G2)

Choose model from the list presented. Once on a specific product, click the “Downloads” tab and scroll to find suitable drivers. Before using the touch screen, it should be calibrated for your system. Please install the 3rd party software and use the Calibrate function.



For additional touch controller/screen documentation and updated drivers, please review documents and material stored inside the 3rd party manufacturer driver packages.



# Installation

# General Installation Recommendations

## Installation and mounting

1. Most of our products are intended for various methods of installation or mounting (panel mounting, bracket mounting, ceiling/wall mounting etc.); for details, please see the relevant mechanical drawings.
2. Adequate ventilation is a necessary prerequisite for the life of the product. The air inlet and outlet openings must definitely be kept clear; coverings which restrict ventilation are not permissible.
3. Generally, do not install the unit in a horizontal position (laying down), as this will cause heat to build up inside the unit which will damage the LCD Panel. To prevent this problem we recommend installing the unit in a vertical position ( $\pm 30$  degrees) to improve the airflow through the unit.
4. To further improve the cooling of the unit we recommend installing Cooling Fans underneath blowing upwards into the unit air inlet. This may be required in high temperature applications and also when there is reason to expect temperature problems due to non-optimal way of mounting.
5. Exposure to extreme direct sunlight can cause a considerable increase in the temperature of the unit, and might under certain circumstances lead to excessive temperature. This point should already be taken into consideration when the bridge equipment is being planned (sun shades, distance from the windows, ventilation, etc.)
6. Space necessary for ventilation, for cable inlets, for the operating procedures and for maintenance, must be provided.
7. If the push buttons of the product are not illuminated, an external, dimmable illumination (IEC 60945 Ed. 4, 4.2.2.3, e.g. Goose neck light) is required for navigational use. The illumination should be free from glare and adjustable to extinction.
8. Information about necessary pull-relievers for cables is indicated in the Physical Connection section of this manual. Attention must be paid to this information so that cable breaks will not occur, e.g. during service work.
9. Do not paint the product. The surface treatment influences the excess heat transfer. Painting, labels or other surface treatments that differ from the factory default, might cause overheating.
10. Exposure to heavy vibration and acoustic noise might under certain circumstances affect functionality and expected lifetime. This must be considered during system assembly and installation. Mounting position must be carefully selected to avoid any exposure of amplified vibration.
11. Additional rules may apply to certain procedures where the symbols  and  are present. For more information, review "IEC62368 policy for Hatteland Technology product" section later in this manual.

# General Installation Recommendations

## General mounting instructions

1. The useful life of the components of all Electronics Units generally decreases with increasing ambient temperature; it is therefore advisable to install such units in air-conditioned rooms. If there are no such facilities these rooms must at least be dry, adequately ventilated and kept at a suitable temperature in order to prevent the formation of condensation inside the display unit.
2. With most Electronic Units, cooling takes place via the surface of the casing. The cooling must not be impaired by partial covering of the unit or by installation of the unit in a confined cabinet.
3. In the area of the wheel house, the distance of each electronics unit from the magnetic standard compass or the magnetic steering compass must not be less than the permitted magnetic protection distance. This distance is measured from the centre of the magnetic system of the compass to the nearest point on the corresponding unit concerned.
4. Units which are to be used on the bridge wing must be installed inside the “wing control console” protected against the weather. In order to avoid misting of the viewing screen, a 25 ... 50 W console-heating (power depending on the volume) is recommended.
5. When selecting the site of a display unit, the maximum cable lengths have to be considered.
6. When a product is being installed, the surface base or bulkhead must be checked to ensure that it is flat in order to avoid twisting of the unit when the fixing screws are tightened, because such twisting would impair mechanical functions. Any unevenness should be compensated for by means of spacing-washers.
7. Products with AC input must be grounded to protective Earth (Safety Ground) when necessary via the bolt (usually on terminal plate) available on the product.  
Products with DC input must be grounded to protective Earth (Safety Ground) via the bolt (usually on terminal plate) available on the product.  
A shorter and thicker cable gives better grounding. A 6mm<sup>2</sup> is recommended, but a 4mm<sup>2</sup> or even 2.5mm<sup>2</sup> can be used for this purpose.
8. Transportation damage, even if apparently insignificant at first glance, must immediately be examined and be reported to the freight carrier. The moment of setting-to-work of the equipment is too late, not only for reporting the damage but also for the supply of replacements.
9. The classification is only valid for approved mounting brackets provided by Hatteland Technology. The unit shall be mounted stand-alone without any devices or loose parts placed at or nearby the unit. Any other type of mounting might require test and re-classification.
10. Additional rules may apply to certain procedures where the symbols ⚠ and ⚡ are present. For more information, review “IEC62368 policy for Hatteland Technology product” section later in this manual.

## Brightness knob precaution

Applies for models with potmeter knob. Please be aware of the risk of breaking or bending the brightness knob. The brightness knob should be free of any obstruction.

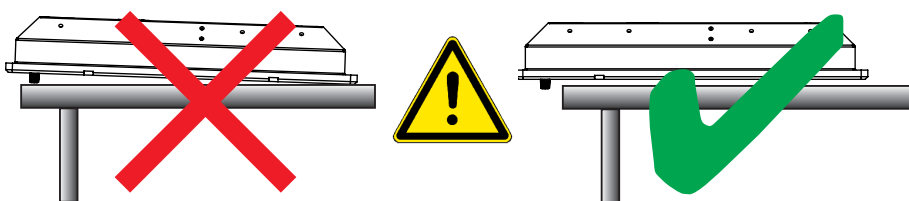

# General Installation Recommendations

## Ergonomics

1. Adjust the unit height so that the top of the screen is at or below eye level. Your eyes should look slightly downwards when viewing the middle of the screen.
2. Adjust screen inclination to allow the angle of gaze to remain at the centre of the screen approximately perpendicular to the line of gaze.
3. When products are to be operated both from a sitting position and from a standing position, a screen inclination of about 30° to 40° (from a vertical plane) has turned out to be favourable.
4. The brightness of displays is limited. Sunlight passing directly through the bridge windows - or its reflection - which falls upon the screen workplaces must be reduced by suitable means (negatively inclined window surfaces, benetian blinds, distance from the windows, dark colouring of the deckhead). However, Series 1 can be offered with optical enhanced technology to reduce reflections and are viewable in direct sun light, but as a general rule the units at the bridge wing area are recommended to be installed or mounted by suitable alignment or bulkhead / deckhead mounting in such a way that reflections of light from the front pane of the display are not directed into the observer's viewing direction.
5. The use of ordinary commercial filter plates or filter films is not permitted for items of equipment that require approval (by optical effects, "aids" of that kind can suppress small radar targets, for example).
6. For ECDIS applications, the minimum recommended viewing distance are as follows:  
(IEC62288, Part 7.5 Screen resolution)

19 inch = 1011mm	20 inch = 878mm	22 inch = 1011mm	23 inch = 1011mm		
------------------	-----------------	------------------	------------------	--	--

## Cables

Use only high quality shielded signal cables and the provided Multifunction Cable.

### ***Cable Entries & Connectors (Marked area) - Illustration only (19 inch used as example)***

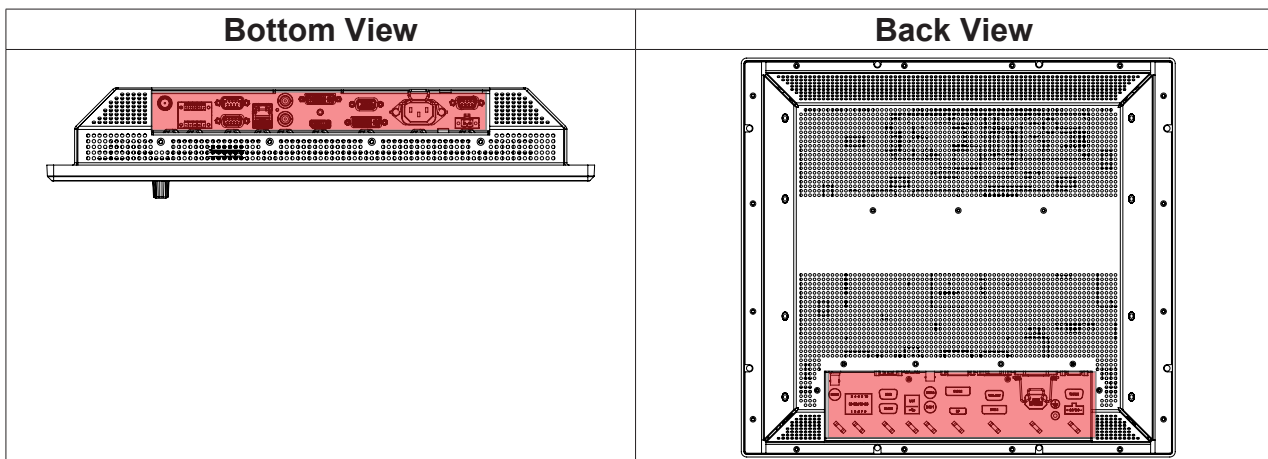

The cable should generally be kept as short as possible to provide a high quality input/output. The maximum signal cable length will depend not only on the signal resolution and frequency, but also on the quality of the signal output from the computer/radar. Recommended refresh rate is 60Hz. Cables up to 10 meters generally provides good picture quality even with a 1600x1200 (UXGA) 60Hz signal. In most cases (especially with lower resolutions) even longer cables will provide a satisfactory result. This should however be tested in advance before making the decision on how far the unit can be placed from the signal source.

# General Installation Recommendations

## Housing / Terminal Block Connector Overview

Housing / Terminal Block connectors are available in different sizes (example 2-pin, 4-pin, 5-pin) which plug into the connector area of the unit. They are mounted by factory default and delivered with the unit. The housing / terminal block connectors have steering rails, which ensures that it can not be mounted wrong. The color of these connectors may vary between black, green and orange depending on manufacturer. You may use approved equivalents of these connectors, but note that the warranty will be void if any damage would occur to either the unit's original PCB terminal socket connector or inside the unit (electronic components, boards etc.).

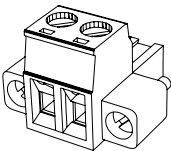
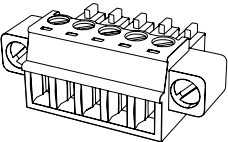
Illustration	Pins	Manufacturer Details	Connector used for module
	2-pin	MSTB 2,5/ 2-STF-5,08 BK  Screwdriver: SZS 0,6x3,5, slot-headed. Tightening torque min. 0.5 Nm. Tightening torque max 0.6 Nm.	• DC Power IN (24VDC) - Single Input  Identified on Hatteland Technology product datasheet as: "Terminal Block 5.08"
	5-pin	MC 1,5/ 5-STF-3,81 Screwdriver: SZS 0,4X2,5mm VDE, slot-headed.  Tightening torque min. 0.22 Nm. Tightening torque max 0.25 Nm.	• RS-422 / RS-485 / SCOM (Serial Remote Control)  Identified on Hatteland Technology product datasheet as: "Terminal Block 3.81"

If your installation requires additional cable fasteners support, please visit and purchase directly from manufacturer: Illustrations below are approximate, actual Housing may deviate slightly, but function remains the same.

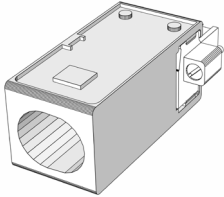
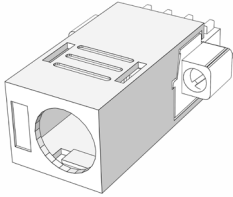
Cable Housing - Illustration	Cover Hood - Illustration
 KGG-MSTB 2,5/ 2 (2-pin) KGG-MC 1,5/ 5 (5-pin)	 BCZ 3.81 AH05 BK BX (5-pin)
<p>For 2-pin and 5-pin:  <a href="https://www.phoenixcontact.com/online/portal/us?uri=pxc-oc-itemdetail:pid=1803934&amp;library=usen&amp;pcck=P-11-02-01&amp;tab=1">https://www.phoenixcontact.com/online/portal/us?uri=pxc-oc-itemdetail:pid=1803934&amp;library=usen&amp;pcck=P-11-02-01&amp;tab=1</a>  <a href="https://www.phoenixcontact.com/online/portal/us?uri=pxc-oc-itemdetail:pid=1834372&amp;library=usen&amp;pcck=P-11-02-01&amp;tab=1">https://www.phoenixcontact.com/online/portal/us?uri=pxc-oc-itemdetail:pid=1834372&amp;library=usen&amp;pcck=P-11-02-01&amp;tab=1</a></p> <p>For 5-pin:  <a href="http://catalog.weidmueller.com/procat/Product.jsp;jsessionid=D399022A1B3211C0146BCBE716D93211?productId=(%5b1005300000%5d)">http://catalog.weidmueller.com/procat/Product.jsp;jsessionid=D399022A1B3211C0146BCBE716D93211?productId=(%5b1005300000%5d)</a></p>	

# General Installation Recommendations

## Configuring Housing / Terminal Block connectors

Below is a brief illustration that might be useful during configuration and installation of such connectors. You will need suitable pre-configured cable(s) and tools to configure the connector(s) and cable(s) that are present in your installation environment. Below is a sample procedure for a 2-pin DC power connector. The procedure is the same for other connectors of this type as listed in table above. Unit used as illustration below is for reference only.

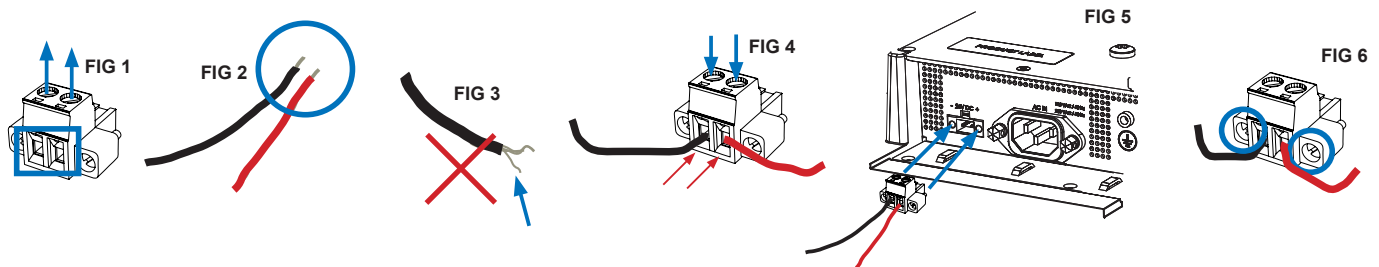

**Requires assembly. It is expected that the technician has experience in electronics and assembling cables and connectors.**

**Warning:** Do not connect or disconnect cables/connectors to the unit's connector while the unit is powered on. Failure to do so may result in damaged electronics.

**FIG 1:** Unscrew (from top) or make sure that the screw terminal is fully open, so you can secure the inserted cables correctly to the loose housing connector (it may already be plugged into the unit as per factory installation).

**FIG 2:** Strip carefully the insulation from the cable to expose the wire(s) inside.

**FIG 3:** Ensure that the wire(s) is without any loose threads to ensure good connection.

**FIG 4:** Insert cables\* (from front) and screw / secure the cables by turning the screw on top of the housing to secure the cables properly. Check that the cables are firmly in place and do not appear loose or fall out when pulling gently.

*\*Note: Required polarization verification (for instance -/+ for DC power input) should conform with the markings on the connector area of the unit. Ignoring the markings on the unit or its add-on modules might damage the unit and/or external equipment in which end, warranty will be void.*

**FIG 5:** Plug the housing into the appropriate connector area of the unit (glass should be facing down) and check again that the cables secured conform with the markings on the connector area of the unit. Finalize the installation by fastening the screws located in front on each side of the housing connector (**FIG 6**).

Connector / Function	Recommended Cable Thickness
2-pin DC Power Input (Terminal Block 5.08)	Minimum 20 AWG - Maximum 18 AWG
4-pin CAN (Terminal Block 3.81)	Minimum 22 AWG - Maximum 20 AWG
5-pin NMEA COM (Terminal Block 3.81)	Minimum 22 AWG - Maximum 18 AWG
5-pin DIO (Terminal Block 3.81)	Minimum 22 AWG - Maximum 18 AWG



## Rotary Bracket and Mounting Bracket (15 inch) combined assembling

Illustration shows "Mounting Bracket JH 15TBR STD-A1" and "Rotary Bracket JH 15TRO STD-A1" combined. The brackets are available separately and are delivered in parts. Some disassembly/assembly is required. Use the provided screws/bolts/nuts included in the package. A stand-alone "Rotary Bracket" can not be mounted to a Display or Panel Computer unit without the "Mounting Bracket" as base first. For alternative drawings/measurements of the brackets, review sales drawing (available on internet or inside user manual).

You must provide your own bolts to secure the completed unit (FIG 3) to the mounting location. Recommended size to mount complete unit is: M10 and minimum 30mm in length. If no Rotary Bracket is present or needed, the Mounting Bracket should be mounted at location with M6 >20mm in length depending on material of table/desktop etc.

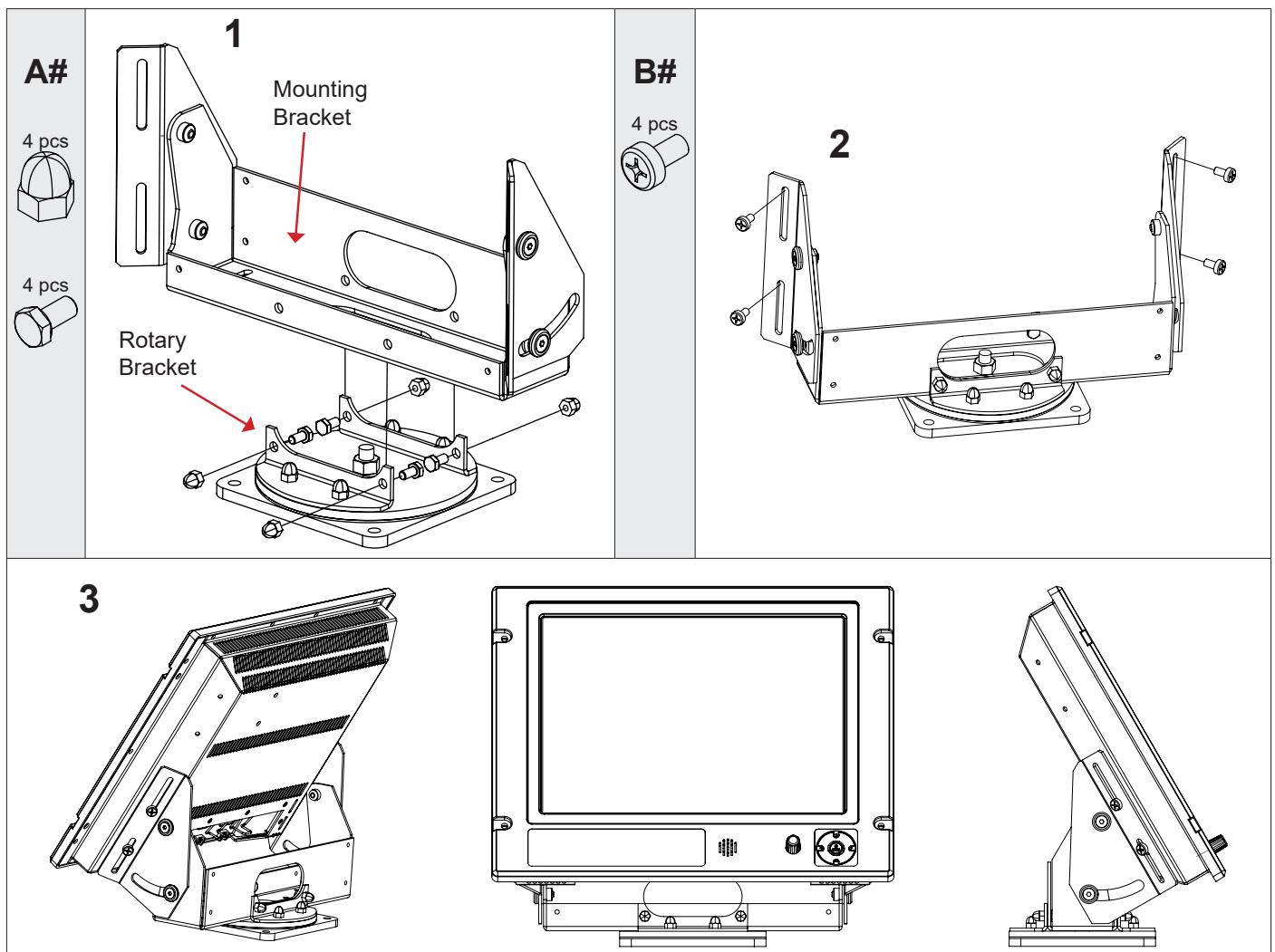

<b>A#</b>	4 pcs: Dome Nut M6, ISO7043, Black + Screw M6x12mm Din933 Black 145 060x012 ZBA
<b>B#</b>	4 pcs: M6 x 1 x 12mm Cross Head Screw (to mount bracket to product)

## Securing Mounting Bracket without Rotary Bracket

Note that the length of bolts should not exceed 12mm (ref: #2 in table above). Using any longer is not possible due to mechanical design inside which are designed to protect the electronics. Review also technical drawings chapter in the user manual for measurements and dimensions of brackets.

- # 1: Mount bolts on each side. Make adjustments before securing the bolts.
- # 2: Adjust the tilting angle and secure the bolts.

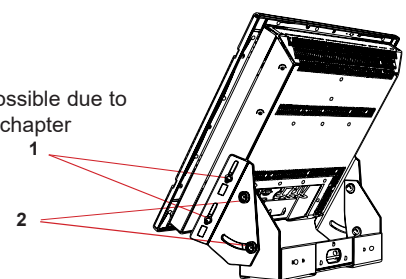

# General Installation Recommendations



## Rotary Bracket and Mounting Bracket - assembling/finalization

Illustration shows Mounting Bracket "JH MMDBR STD-A1" / "JH 23TBR T01" and "Rotary Bracket JH MMDRO STD-A1" combined and not combined. The brackets are available separately and may be delivered in parts. Some disassembly/assembly is required. Use the provided screws/bolts/nuts included in the package. A stand-alone "Rotary Bracket" can not be mounted to a Display or Panel Computer unit without the "Mounting Bracket" as base first. For alternative drawings / measurements of the brackets, review sales drawing (available on internet or inside user manual). The procedure applies for Display and Panel Computers of sizes: 17, 18, 19, 20 and 23 inch.

You must provide your own bolts to secure the completed unit (#A) to the mounting location. Recommended size to mount complete unit is: M10 and minimum 30mm in length. If no Rotary Bracket is present or needed, the completed unit (#B) should be mounted at location with M6 >20mm in length depending on material of table/desktop etc.

Example #A: Mounting Bracket + Rotary Bracket

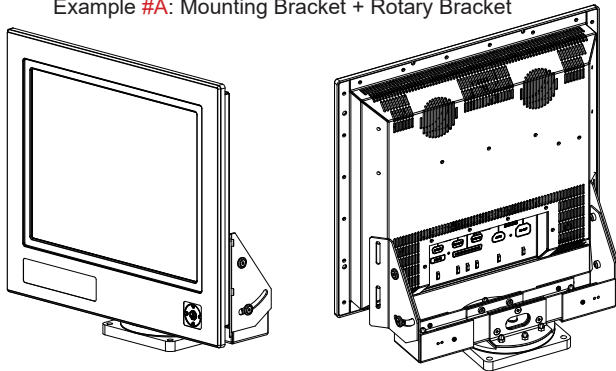

Example #B: Mounting Bracket only

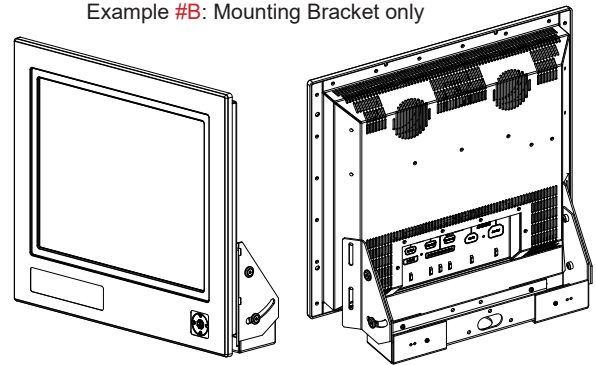

### Contents of kit JH MMDRO STD-A1

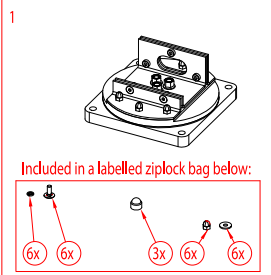

### JH MMDBR STD-A1

Fasteners in JH MMDBR STD-A1 Kit Included in a labelled ziplock bag. Should be used to mount display using cutouts as shown.



All fasteners are black RAL9011 or equivalent.

ID Refer.	Description	Type/number	Note
1+5	4 x DIN 7980 M6x1,6mm	PO21744	
1+5	4 x DIN603 M6x1,6	PO21676	
1+7	3 x ISO7043 M8 SW13 Plastic Cap (Dust Caps)	PO21748	
1+5	4 x DIN1587 M6	PO21644	
1+5	4 x DIN9021 Washer 6,4mm	PO21743	
2+7	3 x DIN 7991 M6x12 - Countersunk Screws	PO21673	
3+4+5	4 x DIN 7985A M4x10	PO21662	
2+4	3 x ISO7043 M8 Nut	PO21645	
8	4 x DIN7985A M6x12	PO21660	Comes with JH MMDBR STD-A1 Kit

Fastener Size	Torque to be used
M4	1.8 ± 0.2Nm (16 ± 2 lbf-in)
M6	7.5 ± 1.0Nm (66 ± 9 lbf-in)
M8	15.3 ± 1.7Nm (135 ± 15 lbf-in)

Creation date / by:  
Last rev. date / by:

### Pre-assembly:

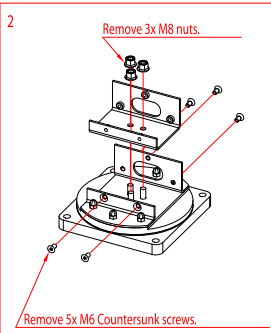

### JH 23TBR T01

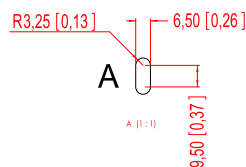

Mounting screws through 6 x holes as indicated above. M6 x >20mm is suggested based on material. Screws not included.

Pos.nr	Antall	Beskrivelse	ID	Materiale
1	1	Bracket skinne	3D004BRS-A2	Aluminium 3mm
2	1	brakettfeste høyre	P000175-1	Aluminium
3	1	brakettfeste venstre	P000175-2	Aluminium
4	1	brakett høyre	P000180-1	Aluminium
5	1	brakett venstre	P000180-2	Aluminium
6	4	Skive mellom brakett og brakettfeste	P000202-1	
7	4	DIN 7985A M4 X 0,7 10 NONE	M4 X 0,7 X 10	
8	4	Flatskive 17W07191	P000197-1	
9	4	underlagsskive M6x1,5mm 48506	P000200-1	
10	4	DIN 7991 M6 X 1 20 NONE	M6 X 1 X 20 HEX	

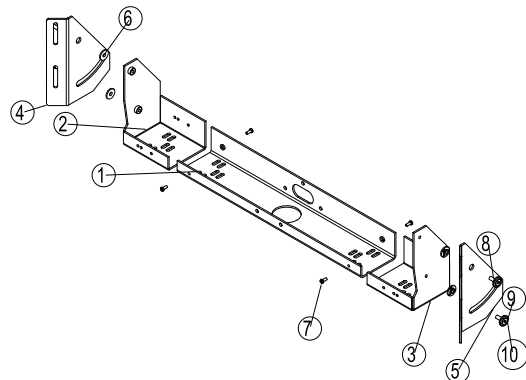

### Contents of kit JH MMDBR STD-A1

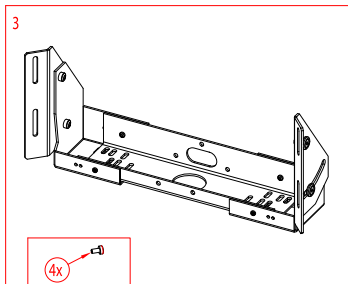

### Tip:

If you need to combine Mounting Bracket "JH MMDBR STD-A1" / "JH 23TBR T01" with Rotary Bracket "JH MMDRO STD-A1" onto Display or Panel Computer unit, please follow Step 1 to 8.

If you need to mount only Mounting Bracket "JH MMDBR STD-A1" to unit, please follow Step 3-4 and Step 5 (re-attach 4 x screws after adjustment based on product size).



## Width adjustment (17"-20"):

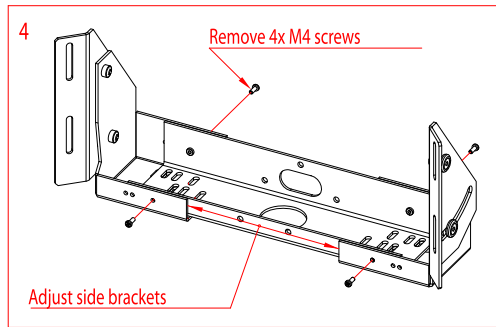

## Fastening after width adjustment:

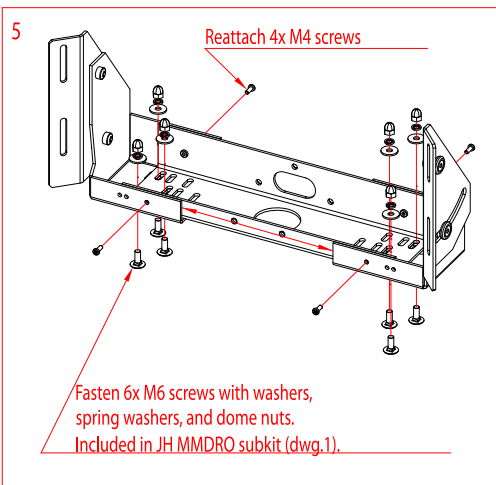

## Assembly MMDRO and MMDBR:

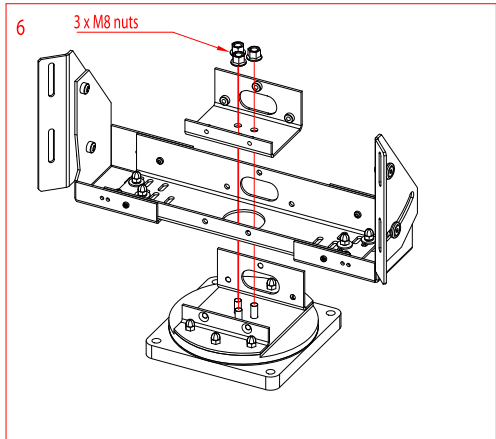

## Assembly MMDRO and MMDBR continued:

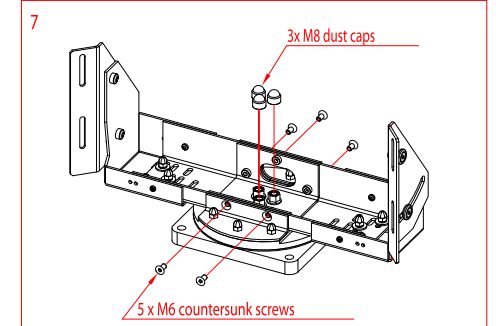

## JH MMDRO STD-A1

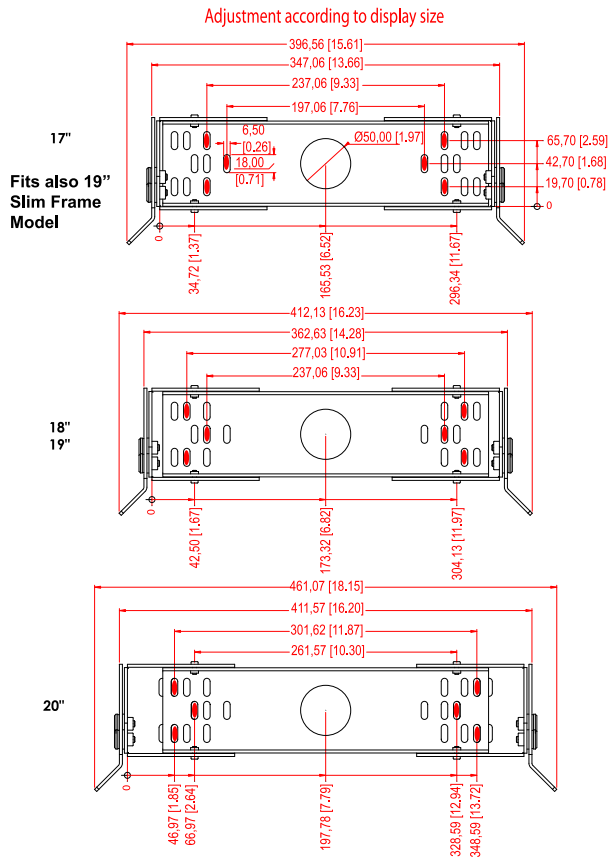

## JH 23TBR T01

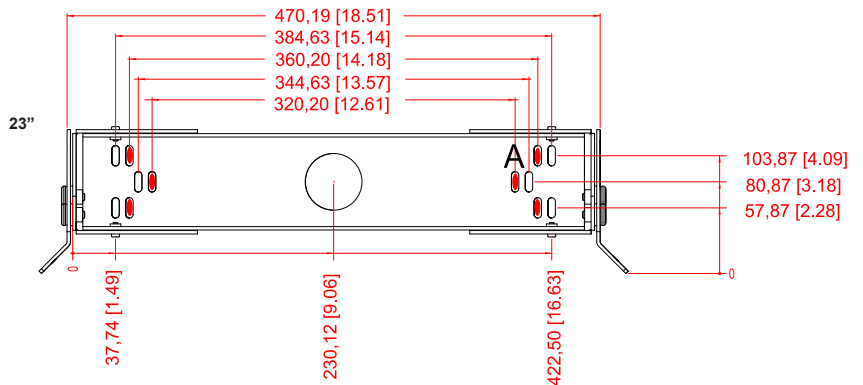

## Completed JH MMDRO STD-A1.

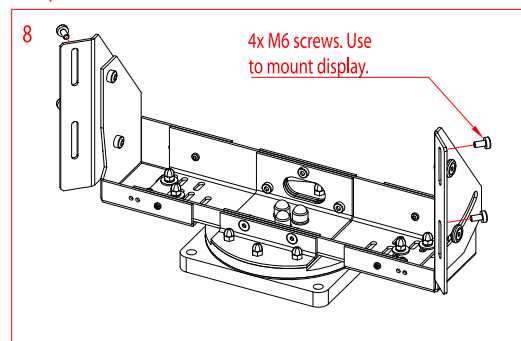

# Physical Connections

## Introduction:

The Maritime Multi Display Series 1 - Generation 2 (G2) has 4 main configurations regarding the connection area. Below are the types of design you may encounter based on model and options chosen. The main physical differences are marked in red circle.

### Connection area 15 inch unit (with Touch Screen and Multi-Power input option)

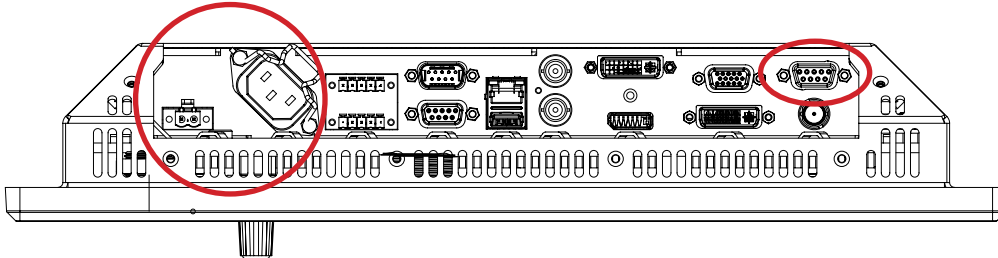

### Connection area 19 inch unit (with Touch Screen and Multi-Power input option)

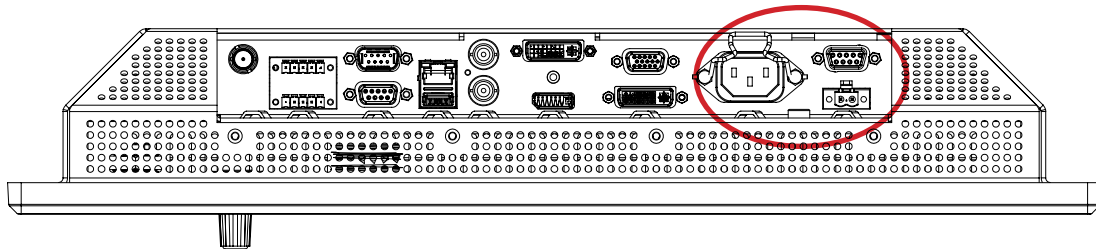

### Connection area 19 inch unit (with Touch Screen Single AC power input option)

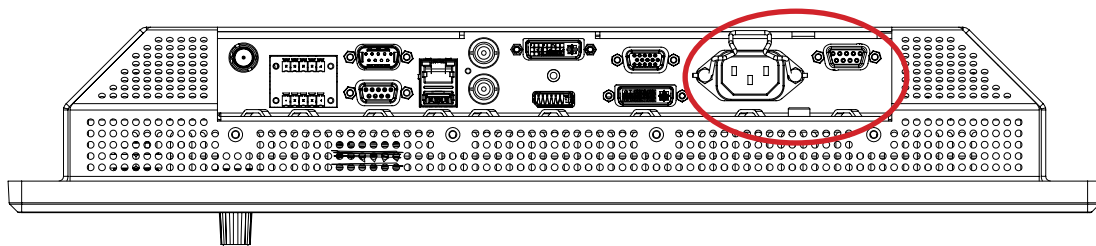

### Connection area 19 inch unit (illustrating no options) - Applies to all model sizes

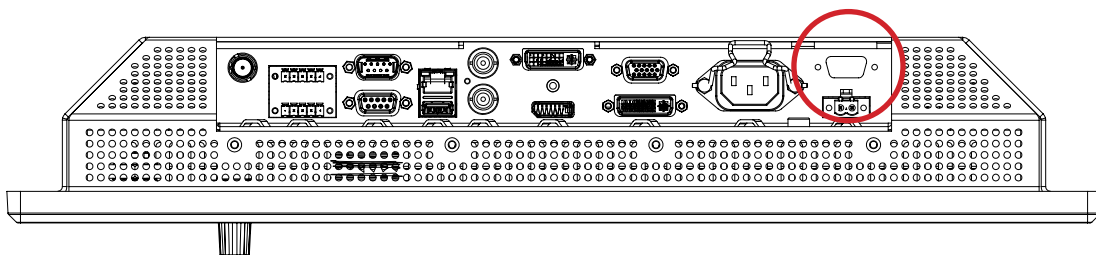

# Physical Connections

## Connector Marking:

All Maritime Multi Display Series 1 - Generation 2 (G2) units has clear silk printed symbols and text illustrating the connector function and type. Factory options are marked with dashed border on silk print.

### Example of Connection area silk print and location (19 inch illustrated below)

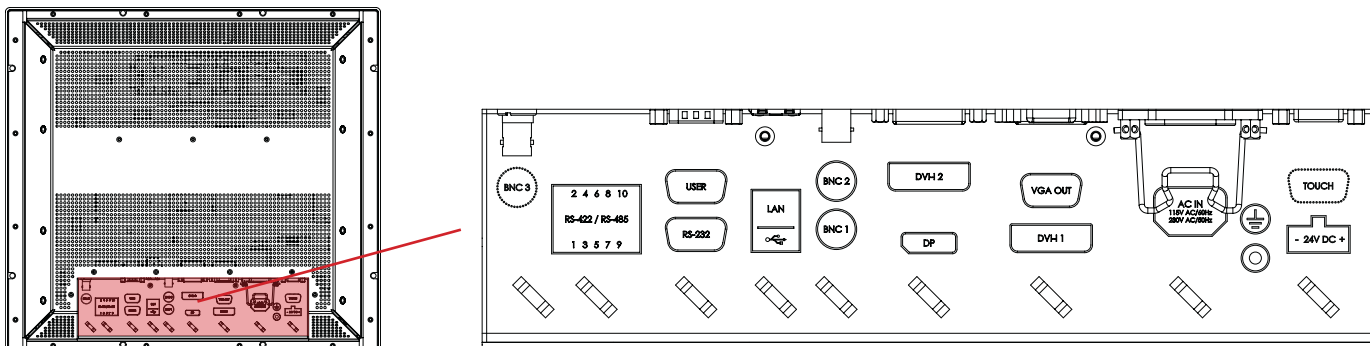

## Cable Tension

To reduce tension on the cables you connect, secure them with a cable tie to the chassis hinges as illustrated.

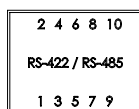
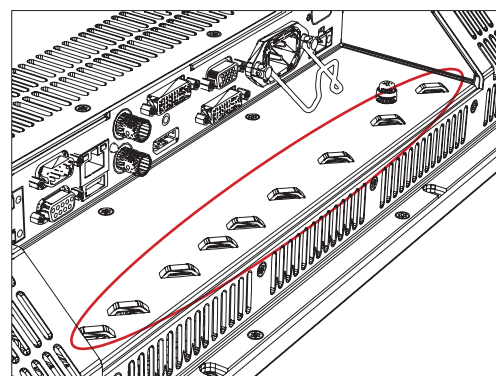

### 2 x RS-422 / RS-485 COM I/O:

The COM (non-isolated RS-422/485) allows functionality to communicate with serial based equipment including controlling internal buzzer externally. Connect and fasten your cables from your compatible external equipment to the 5-pin Terminal Block 3.81 connector. Please review the “Pinout Assignments” chapter as well as “Housing / Terminal Block Connector Overview” in this manual for more information.

Hatteland Technology’s Serial Remote Control Interface (SCOM) protocol document can be downloaded from: <https://www.hattelandtechnology.com/hubfs/pdfget/inb100018-6.htm>



### 1 x USER (POTENTIOMETER INPUT / OUTPUT support):

Allows for controlling Brightness of the displayed image on screen by connecting an external remote control to the D-SUB 9P connector (male) which has Potentiometer IN, +5VDC OUT and BRT +/- IN functionality built in. Review the “Pin Assignments” chapter in this manual for more information on how to activate this functionality.

# Physical Connections



RS-232

## 1 x RS-232 COM I/O:

This D-SUB 9P connector (female) provides additional functionality for the unit. The Serial Remote Control features a RS-232 (non-isolated) interface for controlling internal parameters like brightness. You can access most of the parameters available in the OSD menu and with special commands control the unit externally. This COM can also be used to upgrade the firmware for the graphic controller inside the unit which is available on request and through service channels (for qualified personell only). Fasten your external cable to the D-SUB 9P connector (female) using the provided screws on the cable housing.

Please review “Management Settings/Communication” in the “OSD Menu Functions” chapter for more information.

Hatteland Technology’s Serial Remote Control Interface (SCOM) protocol document can be downloaded from: <https://www.hattelandtechnology.com/hubfs/pdfget/inb100018-6.htm>



LAN

## 1 x Network/LAN INPUT / OUTPUT (NET A):

Supports 10/100/1000Mbps Ethernet (LAN). Suitable for twisted pair cables CAT.5E. Make sure the network cable connector “clicks” into the RJ-45 connector. This connector will allow remote control via SCOM of the display unit to control common functions like brightness, input source and more.

Hatteland Technology’s Serial Remote Control Interface (SCOM) protocol document can be downloaded from: <https://www.hattelandtechnology.com/hubfs/pdfget/inb100018-6.htm>



USB

## 1 x USB SCOM:

Connect a TYPE A USB Cable between this connector and your PC. Port is USB2.0 (<5m). This connector will allow remote control via SCOM of the display unit to control common functions like brightness, input source and more.

Hatteland Technology’s Serial Remote Control Interface (SCOM) protocol document can be downloaded from: <https://www.hattelandtechnology.com/hubfs/pdfget/inb100018-6.htm>



BNC 1



BNC 2



BNC 3

## 3 x COMPOSITE IN/VIDEO IN:

Connect your BNC cable connector (male) to the BNC Connectors (female) on the unit. This will allow 3 video signals from i.e. cameras & dvd players to be visible on screen either as full screen video or Picture-In-Picture/Picture-By-Picture. To activate any of these functionalities, the unit must be configured via the OSD menus (see own chapter). PAL / NTSC / SECAM VIDEO signal formats supported.



DP

## 1 x DisplayPort (DP) IN:

Connect your DP (male) cable to the DisplayPort (v1.2) 20P connector (female) of the unit. The DP has its own locking mechanism that locks the plug inserted. Make sure the plug “clicks” into place to verify a proper and secure connection.

# Physical Connections

 DVI-I 1 DVI-I 2

## 2 x DVI-I IN:

Connect your DVI cable to any of the two DVI-I 29p connector (female). Secure your DVI cable to the hex spacers provided on the unit and make sure you do not bend any of the pins inside the connector. Connect the other end of the cable to the DVI connector on your equipment and secure it.

Note for DVI and VGA signal inputs:

DVI-I #1, DVI-D #1 and VGA #1 is Single Link. DVI-I #2, DVI-D #2 and VGA #2 is Dual Link.

## Important note for DVI signal detection:

*Please note that for the operating system to detect DVI signals correctly, the DVI cable MUST be connected physically to the unit during boot up otherwise you may experience a black image. Furthermore certain graphics drivers may need to refresh their device list (often done manually by user - detect devices), while in some cases the Plug-n-Play will automatically detect the DVI signal correctly. Please consult your local technician if you have this behavior of detection problems when using DVI. In all cases the problem can be solved in the operating system, and this is not a malfunction in the graphic controller for display units.*

 VGA OUT

## 1 x VGA OUT:

VGA OUT enables a direct clone of the incoming VGA signal if using a DVI-I to VGA adapter. Connect the cable to the D-SUB 15P connector (female) and secure it to the hex spacers provided on the unit. Connect the other end to your equipment and secure it. Note that only DVI-I port #1 supports cloning.

 AC IN  
115V AC/60Hz  
230V AC/50Hz

## 1 x AC POWER INPUT:

The internal AC power module supports both 100VAC/60Hz and 240VAC/50Hz power input.

 - 24V DC +

## 1 x DC POWER INPUT:

Connect your DC power cable to the 2-pin Terminal Block 5.08 connector. The internal DC power module supports 24VDC. For more information, please review "Housing Connector Overview" earlier in this manual.



## 1 x GROUNDING SCREW:

Please review "General Installation Chapter", pt. 7 for more information.

Note for Grounding Screws: Standard Grounding Screw/Bolt provided by Hatteland Technology is "Pan head screws M4x8mm w/spring and plainwasher".

## Multi-power note: (For units supporting AC & DC input simultaneously)

*The unit has a dual input power supply which will accept both AC and DC input. If both inputs are connected, the unit will be powered by AC. If AC is disconnected it will automatically switch over to DC without affecting the operation of the unit. This makes it possible to use AC power as primary power and a 24V battery as secondary power, eliminating the need for expensive UPS systems.*

 TOUCH

## 1 x COM TOUCH (factory option):

This 9P DSUB (female) COM connector provides touch screen communication for units that have been equipped with a factory mounted touch screen. It should be connected to a computer with touch screen drivers installed. See the touch screen chapter in this manual for more information.

This page left intentionally blank



# Operation

## USER CONTROLS OVERVIEW

The units are available in two different factory user control configurations as illustrated below.

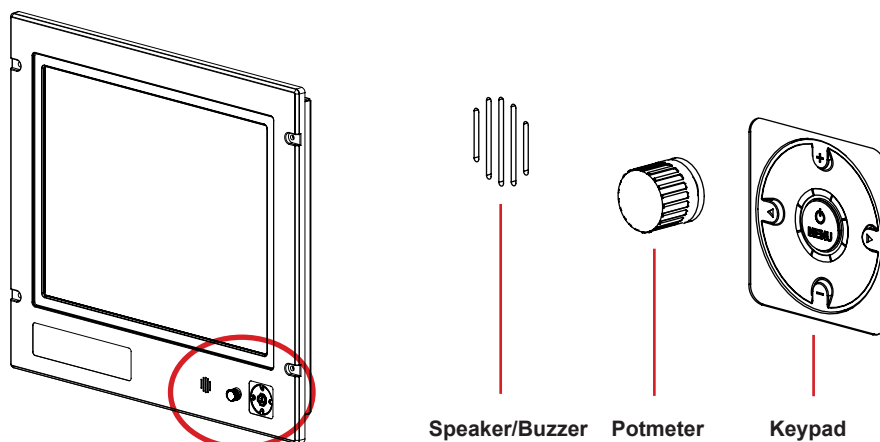

#1: Potmeter & buzzer (introduced Q4 2008) including keypad controls with its Status LED Ring. Brightness for the unit is adjusted by using the potmeter. The tactile keypad control provide access to the configuration menu and Direct Access / Hotkeys functionality. The speaker/buzzer function provide audible alarm functionality routed via the Multifunction Cable.

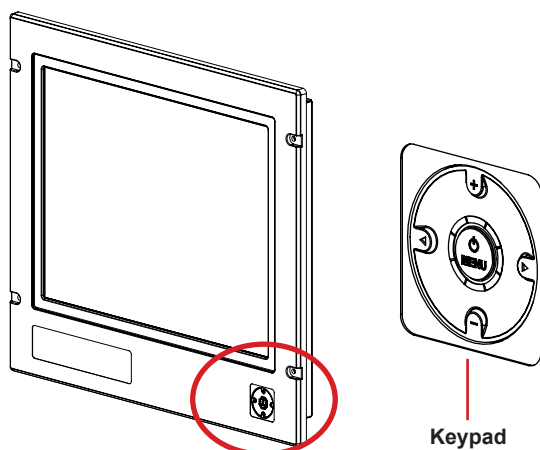

#2: The tactile only keypad controls with 5 push buttons (introduced Q2 2007) and the Status LED Ring. The keypad provide the user to control brightness, access the configuration menu and use the Direct Access / Hotkeys functionality. The LED ring will provide feedback for various status or modes that the unit can or currently operates in.

### **Power ON:**

To turn the unit on, push the navigator MENU button inwards and release it instantly. The unit will start searching for signal sources. A green led will move around the led ring to indicate the search procedure. Please consult the STATUS LED overview later in this chapter for the various LED patterns that can occur.

### **Power OFF:**

To turn the unit off, push the navigator MENU button inwards and hold it down for 6 seconds. After the first 3 seconds the menu will appear. 3 seconds later the unit is turned off and all LED indicators will turn red. You can now release the power button. Please consult the STATUS LED overview on the next page for the various LED patterns that can occur.

## KEYPAD FUNCTIONALITY

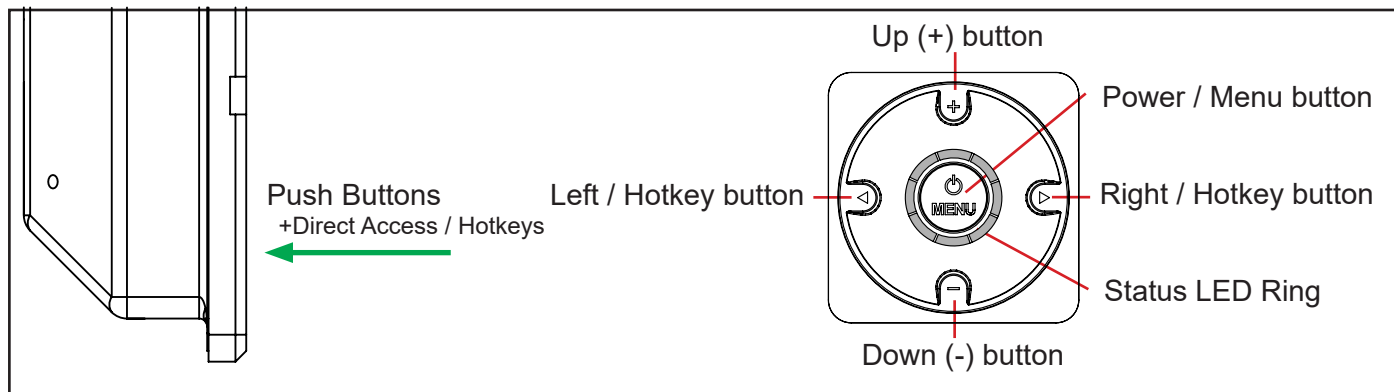

### **MENU** function as:

Power On/Off & On Screen Display (OSD) menu access.

### **LEFT (◀)** function as:

Direct Access / Hotkey, exit the current function and navigate to the previous OSD menu.

### **RIGHT (▶)** function as:

Direct Access / Hotkey, enter sub-menu & execute/set selected function.

### **UP (+)** function as:

Increase brightness, adjust positive values, visual movement, OSD menu navigating upwards & confirm.

### **DOWN (-)** function as:

Decrease brightness, adjust negative values, visual movement, OSD menu navigating downwards & confirm.

## **DIRECT ACCESS / HOTKEY FUNCTION**

You can access a number of functions from within the OSD Menu which is normally only accessible by browsing through the OSD Menu and locate the function manually. The Direct Access function are assigned to the Left and Right buttons to function as hotkeys. Note that some functions are dual (increase/decrease) or just single (swap/next). Those with single functionality both the left and right keypad button will perform the same action.

To configure the Direct Access / Hotkeys functionality, just press one of the buttons inwards and release it instantly, detection time is immediate.

Available assigned functions for Direct Access are: **Brightness, PIP Size, Main Source, Second Source, Alpha Blend, Video Scaling, Swap Source, Test Pattern and No Function.**

Please review the "OSD Menu Function" chapter for configuring the direct access / hotkeys functionality.

# Status LED Overview

## Status LED Overview

The unit features a multi purpose indicator LED status ring which through different patterns. Realtime activity gives back the status of the signal detected, power on/off, calibration, menu activity and more. The LEDs are multicolored which either illuminate green or red, based on the activity.

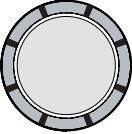
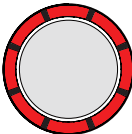
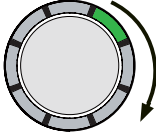
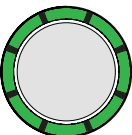
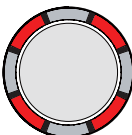
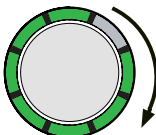
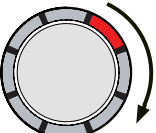
<p><b>OFF (No power connected)</b></p>  <p>8 LED OFF</p>	<p><b>OFF (Standby, power detected)</b></p>  <p>8 RED LED STATIC ON</p>	<p><b>ON (Signal Search)</b></p>  <p>1 GREEN LED MOVEMENT looping.</p>
<p><b>ON (Signal OK)</b></p>  <p>8 GREEN LED STATIC ON</p>	<p><b>ON (No Signal)</b></p>  <p>4 RED LED STATIC ON</p>	<p><b>ON (Menu Delay)</b></p>  <p>7 GREEN LED STATIC + 1 LED OFF MOVEMENT doing 1 loop.</p>
<p><b>OFF (Shutdown)</b></p>  <p>1 RED LED MOVES for 3 sec. After additional 3 secs, all leds turns RED.</p>		

## For ECDIS Calibrated Products

For units that are ECDIS calibrated from factory, the following LED pattern (Calibrated) indicates that the backlight/brightness is at calibrated level. **(Calibrated +)** or **(Calibrated -)** means that the brightness adjustment value is above or below the calibrated brightness level. Fine adjust the brightness in terms of decreasing or increasing the value until the pattern for **(Calibrated)** is reached.

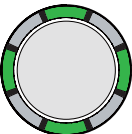
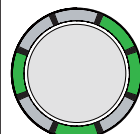
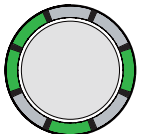
<p><b>ON (Calibrated)</b></p>  <p>4 GREEN LED STATIC ON</p>	<p><b>ON (Calibrated +)</b></p>  <p>4 GREEN LED STATIC ON + where 1 show BRIGHTNESS INDICATION POSITION</p>	<p><b>ON (Calibrated -)</b></p>  <p>4 GREEN LED STATIC ON + where 1 show BRIGHTNESS INDICATION POSITION</p>
--	--	--

## On Screen Display (OSD) Menu Introduction

The OSD menu consists of main menus and submenus which are very easy to navigate through. All functions are explained in-depth later in this user manual. Prior to using the OSD menu, you should be sure to familiarize yourself with how to physically access the menu, how to navigate up/down/left/right, how to modify values, exiting menus and more.



**Please note: Factory default illustrations only! Available functions, icons and text may deviate slightly from actual OSD menu on your product due to different OSD software configurations and customized solutions.**

## OSD Key Code (password) overview

During use/accessing the OSD menu, based on factory default or customized configuration, there might be a pop-up requester asking for a Key Code (password) to gain further access to requested menu. These are 3 digits long.

Keycode	Description
321	Applies for "ECDIS Compliance" products. Code must be entered to get access to OSD MENU. Configured in OSD parameter: "OSD Settings > OSD Lock Mode > Menu Protect"
362	If OSD are in Basic Mode, entering code gets access to Advanced Mode. Configured in OSD parameter: "OSD Settings > OSD Mode > Advanced"
---	Service Mode - Only applicable for authorized service personnel. Configured in OSD parameter: "OSD Settings > OSD Mode > Service"

# OSD Menu Overview

## OSD Keycode / OSD Lock Mode

During use, a small requester may pop-up on screen asking you for a “Key Code”. This is a safety feature (due to ECDIS Compliance) that might be predefined in your setup. To quickly understand how to enter a code, navigate and finally access the underlying main menu, simply follow the illustration below. The “Key Code” is factory default set to “321”. If the “Key Code” requester do not appear on screen, you can skip reading this section for now and proceed to the next page.

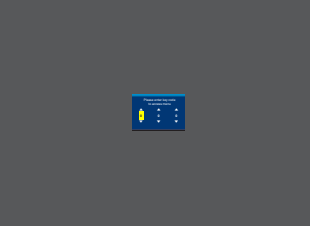
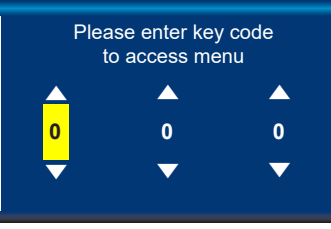
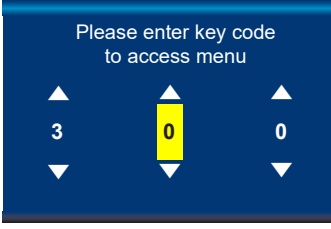
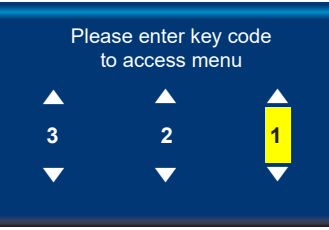
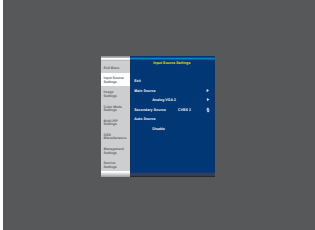
 <p>Active Display Area + Requester</p>	 <p>Close-up of Requester</p>	 <p>Close-up of Requester</p>
<p>1: Typical position of requester on screen. Yellow box indicate number position, default location is always on first number.</p>	<p>2: Enter first number (from 0 to 9). Use “Navigation/Hot Keys” touch buttons to increase/decrease. Number change in real time.</p>	<p>3: Now touch menu button to store first number and proceed to second number. Yellow bar will move its position too.</p>
 <p>Close-up of Requester</p>	 <p>Active Display Area + OSD Menu</p>	
<p>4: Repeat step 2 and 3, until “Key Code” reads “3 2 1” and finally touch menu button to continue.</p>	<p>6: The OSD menu appear by default in the middle of Active Display Area</p>	

After the code is successfully entered you will gain access to the OSD Menu and a multitude of functions will be available for adjusting or reviewing. Please proceed to the next page, where you will learn the differences between the different menu modes and a complete map of all the underlying functions available within.

# OSD Menu Overview

## OSD “Basic”, “Advanced” & “Service” Menu modes



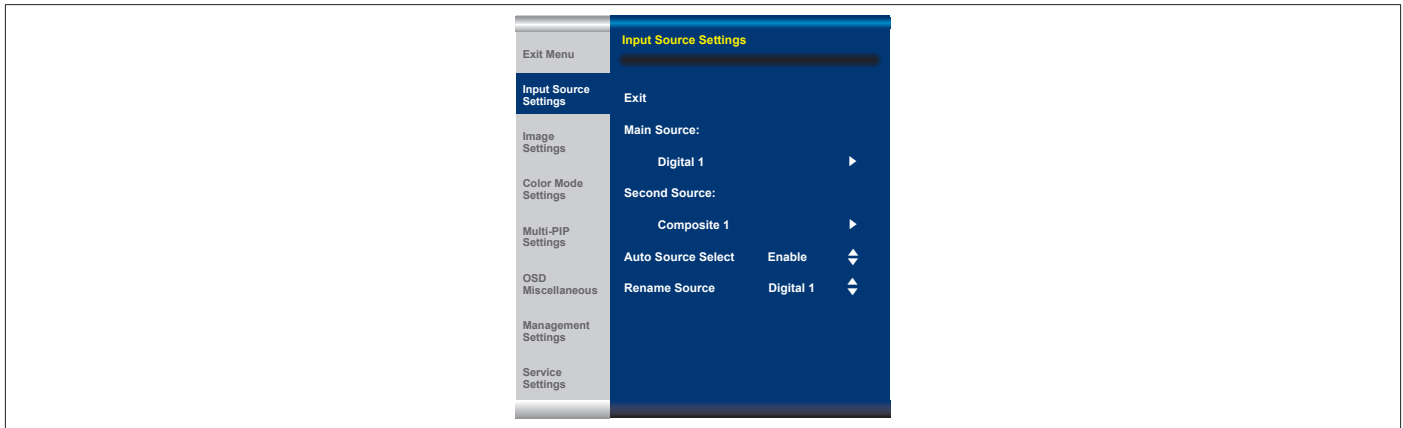

Three OSD Modes are available. The “Basic” Menu mode offers easy and clear access to most commonly used functions. The “Advanced” Menu mode offers a more advanced menu with technical information and is suited for more technical minded users and the “Service” Mode reveals more options in “Service settings” for service purposes. “Advanced” and “Service” modes are password (KeyCode) protected. Password for Advanced Mode is “362”, Password for Service Mode is intentionally only available from Service Partners and our HelpDesk which should only be used by experienced personnell. Please contact your Service Partner or our HelpDesk to retrieve the password.



OSD Menu showing for example “Input Source Settings” chosen in the menu. The left menu bar is visible at all times, while the right section will change based on contents of that submenu. The design and size of OSD menu area does not change, even in any of the “Basic”, “Advanced” and “Service” mode settings.

## OSD Visual Feedback (examples)

Throughout all OSD menus there are certain symbols you need to familiarize yourself with. These are to visually indicate that a value can be increased/decreased, accessed, display a Slide Bar Meter or just for information purposes only. All functions with arrows have text based, human readable lists with start and end choices. A Slider Bar with number beside it will indicate the value has a minimum, current and max limit. All changes in values and lists happen in real time as you touch the menu button and/or touch navigation buttons.

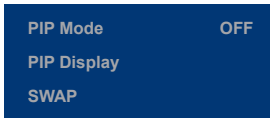
	
<p>Arrow pointing right means that there is a submenu available for this function for further adjustments and functions.</p>	<p>Arrow pointing up/down means that the current choice can be changed in-place from a list that has a start and end.</p>
	
<p>Slider Bar meter indicates the “filling” up based on a minimum and maximum value. The current value is written to the right.</p>	<p>Whenever a function is selected, the item will be visually indicated with a yellow bar behind it. The other choices available will be in white text with no yellow bar behind.</p>
	
<p>Functions displayed in Green Color indicates either the current stored value of the function and sometimes to draw user’s attention towards information about a selected function or its current state.</p>	<p>Functions displayed in gray text means that set of functions may depend on a different option to be turned on or configured first. In this example, “PIP” functions are all unaccessible, since “PIP Mode” is “OFF”.</p>

Note: The examples above are the most common ones displayed. Your menu may have slight different style and colors, depending on firmware, variations and customized solutions, but the logic of operation is the same.

# OSD Menu Overview

## OSD Menu Structure

In this table all functions within menus and their submenus are shown. Functions that begins with an asterix (\*) and in **bold/red font color** style indicates this function/menu is only available during “Advanced” menu mode or during Video CVBS fullscreen. Functions that begins with an asterix (\*) and in **bold/blue color** indicates this function is only available while in “Service” menu mode. Functions with a “>” in the end, indicates a submenu or list of options will be displayed. Depth of the sub-menus (levels) are identified from 1 to 5.

## Input Source Settings

Level 1 (Main Menu)	Level 2	Level 3	Level 4	Level 5
Exit				
Input Source Settings >	< Exit			
	Main Source >	< Exit		
		Digital 1, Digital 2, Analog RGB1, Analog RGB2, Composite 1, Composite 2, Composite 3, DisplayPort1	(Text Displayed)	
	Second Source >	< Exit		
		Digital 1, Digital 2, Analog RGB1, Analog RGB2, Composite 1, Composite 2, Composite 3, DisplayPort1	(Text Displayed)	
	Auto Source Select >	< Exit		
	DVI-I1 Mode		DVI Mode/VGA Mode/Auto Mode	
	DVI-I2 Mode		DVI Mode/VGA Mode/Auto Mode	
	Auto Source Selection		Enable/Disable	
Rename Source >	<On Screen Keyboard Input>			

## Image Settings

Level 1 (Main Menu)	Level 2	Level 3	Level 4	Level 5	
Image Settings >	< Exit				
	Auto Position >	(Automatic Action)			
	Auto Color Balance >	No/Yes			
	<b>*Brightness &gt;</b>	(Slider Bar 0~255)			
	<b>*Contrast &gt;</b>	(Slider Bar 0~255)			
	<b>*Saturation &gt;</b>	(Slider Bar 0~255)			
	<b>*Hue &gt;</b>	(Slider Bar 0~255)			
	Sharpness >	(Slider Bar 0~24)			
	Display >	< Exit			
		H. Position >		(Slider Bar 0~100)	
		V. Position >		(Slider Bar 0~100)	
		Clock >		(Slider Bar 0~100)	
		Phase >		(Slider Bar 0~100)	
		Picture Direction >		Select 0/180	
	<b>*Video Setup &gt;</b>	< Exit			
		Main MADI Mode >		Normal, Adaptive, Off	
		Noise Reduction >	< Exit		
Dynamic NR Mode >					High, Medium, Low, Adaptive, Off
MPEG NR Mode >					On, Off
Sharpness Noise Coring >				High, Medium, Low, Adaptive, Off	
Film Mode >		2:2, 3:2, 3:2-2:2, Off			
DCDi >		On, Off			

# OSD Menu Overview

## Color Mode Settings

Level 1 (Main Menu)	Level 2	Level 3	Level 4	Level 5
Color Mode Settings >	< Exit			
	Color Temperature >	9300K, 8000K, 6500K > User >	(Automatic Action)	
			< Exit	
			Red >	(Slider Bar 0~255)
			Green >	(Slider Bar 0~255)
			Blue >	(Slider Bar 0~255)
	*Gamma >	No Calibration, Calibration VGA, Calibration DVI, Calibration DisplayPort		

## Multi-PIP Settings

Level 1 (Main Menu)	Level 2	Level 3	Level 4	Level 5	
Multi-PIP Settings >	< Exit				
	PIP Mode >	PIP Off, PIP Child, PIP Split, PIP Wide.			
	PIP Display >	< Exit			
		PIP Child Size >		< Exit	
				PIP Size >	(Slider Bar 1~9)
				PIP H-Size >	(Slider Bar 0~20)
			PIP V-Size >	(Slider Bar 0~20)	
		PIP Position >		< Exit	
			PIP H-Position >	(Slider Bar 0~100)	
			PIP V-Position >	(Slider Bar 0~100)	
	Swap Source >	(Automatic Action)			
	PIP Picture >	< Exit			
		Brightness >		(Slider Bar 0~255)	
Contrast >			(Slider Bar 0~255)		
Saturation >			(Slider Bar 0~255)		
Hue >			(Slider Bar 0~255)		
	Sharpness >		(Slider Bar 0~24)		

# OSD Menu Overview

## OSD Miscellaneous

Level 1 (Main Menu)	Level 2	Level 3	Level 4	Level 5	
OSD Miscellaneous >	< Exit				
	OSD Position >	< Exit			
			OSD H. Position >	(Slider Bar 0~255)	
			OSD V. Position >	(Slider Bar 0~255)	
	Language >	< Exit			
			Norsk >	(Select for Norwegian)	
			English >	(Select for English)	
			Français >	(Select for French)	
			Deutsch >	(Select for German)	
			Italiano >	(Select for Italian)	
			日本語 >	(Select for Japanese)	
			簡體中文 >	(Select for Simplified Chinese)	
	Presets >	< Exit			
			Recall >	(Automatic Action) Performs Factory Defaults!	
			Save >	< Exit	
				User 1 to 5 >	(Automatic Action)
			Load >	< Exit	
				User 1 to 5 >	(Automatic Action)
	OSD Timeout (Sec) >		(Slider Bar 0~30)		
	OSD Transparent >		(Slider Bar 0~255)		
	OSD Mode >	< Exit			
			Basic >	(Select)	
			Advanced >	(Select) and Enter Key Code "362"	
			Service >	(Select)	
	<b>*OSD Lock Mode &gt;</b>		Normal Mode >	(Select)	
			Menu Protect >	(Select) and Enter Key Code "321"	
			Full Protect >	(Select) and Enter Key Code "321"	
<b>*Hot Key Assignment &gt;</b>		Key 1 >	OSD Language, Test Pattern, Swap Source, Graphic Scaling, PIP Mode, Second Source, Main Source, PIP Child Size, Black Level, No Function		
		Key 2 >	OSD Language, Test Pattern, Swap Source, Graphic Scaling, PIP Mode, Second Source, Main Source, PIP Child Size, Black Level, No Function		
<b>*OSD Key Outdoor &gt;</b>	< Exit				
		On / Off			
Spectrum >		(Slider Bar 0~512)			
<b>* Keep OCM Mode &gt;</b>		On / Off			

# OSD Menu Overview

## Management Settings

Level 1 (Main Menu)	Level 2	Level 3	Level 4	Level 5	
Management Settings >	< Exit				
	* <b>Graphic Scaling &gt;</b>	< Exit			
		Graphic Scaling >	Full Screen, Fill to Aspect Ratio, One To One		
		Zoom >	(Slider Bar 0~100)		
		Horizont Stretch >	(Slider Bar 0~100)		
		Vertical Stretch >	(Slider Bar 0~100)		
		Auto Adjustment >	On, Off		
		* <b>Unknown Timing Search &gt;</b>	< Exit		
			Auto Mode >	< Exit	
				Display Size >	4:3, 5:4, 1:1, 16:9, 16:10
				Execute >	(Automatic Action)
			Blind Mode >	< Exit	
				H. Resolution >	(Slider Bar 0~2000)
				V. Resolution >	(Slider Bar 0~2000)
				Total H. Line >	(Slider Bar 0~2000)
				H. Blank Pixels >	(Slider Bar 0~500)
				V. Blank Pixels >	(Slider Bar 0~500)
				Execute >	(Automatic Action)
			Save Timing >	Save Timing 1 to 8 >	(Automatic Action)
			Clear Timing >	Clear Timing 1 to 8 >	(Automatic Action)
		* <b>GDC Sensitivity &gt;</b>	(Slider Bar 0~255)		
		* <b>Filter &gt;</b>	Enable, Disable		
		* <b>Communication &gt;</b>	< Exit		
			RS232 >	(Select)	
			2-wire RS-485 >	(Select)	
			4-wire RS485/422 >	(Select)	
			Address RS >	(Slider Bar 0~15)	
			IP Address >	Auto IP >	(Select)
				Fixed IP >	(Number Input; xxx.xxx.xxx.xxx)
			USB	(Select)	
			Enable RS232	Enable, Disable	
			FW Download >		
		* <b>Power Plan &gt;</b>	< Exit		
			VGA Out / USB in OFF Mode >	Enable, Disable	
			LAN in OFF / Sleep Mode >	Enable, Disable	
		* <b>Touch Power Enabled &gt;</b>	< Exit		
			Always Active >	(Select)	
			Any signal is On >	(Select)	
			Select signal is On >	< Exit	
				Digital 1 >	(Select)
			Digital 2 >	(Select)	
			Analog RGB 1 >	(Select)	
			Analog RGB 2 >	(Select)	
			Composite 1 >	(Select)	
			Composite 2 >	(Select)	
			Composite 3 >	(Select)	
			DisplayPort 1 >	(Select)	
	* <b>External Power Button &gt;</b>	Enable, Disable			
	* <b>DDC/CI Setting &gt;</b>	Digital 1, Digital 2, Analog RGB1, Analog RGB2, DisplayPort 1, None			

# OSD Menu Overview

## Service Settings

Level 1 (Main Menu)	Level 2	Level 3	Level 4	Level 5
Service Settings >	< Exit			
	Video Scaler Firmware Ver >	(Text Displayed)		
	uC Firmware >	(Text Displayed)		
	Elapsed Time >	(Text Displayed)		
	Current Temp >	(Text Displayed)		
	*Fault Status >	(Text Displayed)		
		*< Exit		
		NVRAM >	(Text Displayed)	
		Ethernet >	(Text Displayed)	
		GDC >	(Text Displayed)	
		TMP Sensor >	(Text Displayed)	
		Video Scaler >	(Text Displayed)	
		Test Pattern >	(Automatic Action)	
		*Burn In >	Enable, Disable	
	*Smart ISP >	(Select)		
	*Watchdog Test >	(Select)		

# OSD Menu Functions

## On Screen Display (OSD) Menu Functions

The following section covers all possible settings that the user can (in a certain mode) encounter or needs to adjust via easy understandable menus, text and navigation. For simpler reading the menu choice **"Exit"** has been left out of description in this chapter intentionally. Whenever **"Exit"** is available, you can exit current menu and go back to the previous one visited. When there are no more previous menus available, the OSD menu overlay will be shut off and hidden. All settings are saved real-time or when you exit any menu (including time out of menu visibility).

The number shown in the "|-----x-----" line gives the indication of the submenu level where the function is located (also reference to the table in the previous chapter). It requires the user to touch the "MENU" symbol to enter that submenu.



**Please note: Available functions described may deviate slightly from actual OSD menu on your unit. This is due to different OSD software configurations and customized solutions. Shown here are factory standards.**

### Input Source Settings

Lets you configure Main and Secondary signal source inputs (DVI, DisplayPort, VGA or Composite video signals) as well as activate or disable the Auto Source functionality. The contents of these submenus are listed below.

- Note: Switch time between sources is ~5 sec.

#### |---2--- Input Source Settings - Main Source

The possible signal inputs are; "Digital 1" (DVI), "Digital 2" (DVI), "Analog VGA1" (RGB/VGA), "Analog VGA2" (RGB/VGA), "Composite 1", "Composite 2", "Composite 3" (Composite Video) and DisplayPort 1 (DP). Composite Video inputs supports standard PAL/NTSC/SECAM signals.

- Note: The current active main source name will be greyed out in the list. By factory default, "Digital 1" (DVI) are assigned as Main Source. The current active main source will be shown in green color at the bottom of this menu.

#### |---2--- Input Source Settings - Second Source

The possible signal inputs are; "Digital 1" (DVI), "Digital 2" (DVI), "Analog VGA1" (RGB/VGA), "Analog VGA2" (RGB/VGA), "Composite 1", "Composite 2", "Composite 3" (Composite Video) and DisplayPort 1 (DP). Composite Video inputs supports standard PAL/NTSC/SECAM signals.

- Note: The current active secondary source name will be greyed out in the list. Also, if DVI, VGA or DP are defined as Main Source, they cannot be re-selected as second source as well. The second source is used together with Main Source for the Picture-in-Picture (PIP) functionality. PIP only works with one source of DVI/DP/VGA together with Composite Video sources. By Factory default "Composite 1 (Video)" are assigned as the second source. The current active main source will be shown in green color at the bottom of this menu.

**Please note: Only one VGA Source can be defined as either Main or Single. Unit does not support dual VGA sources defined as Main+Source. Valid options are 1 x VGA + any of the other Digital based sources.**

## OSD Menu Functions

### Input Source Settings - DVI-I1 Mode

This OSD setting item is used to select the DVI-I1 port operating mode.

#### Settings as follows:

- DVI Mode = The port is locked to DVI-D mode, only accepting digital input. "Analog RGB1" option in input source selection will be disabled.
- VGA Mode = The port is locked to VGA mode, only accepting analog input. "Digital 1" option in input source selection will be disabled.
- Auto Mode = The port can work in both DVI-D and VGA mode.

Note: For graphic cards that comes with DVI-I output, it is suggested to lock the operating mode to DVI mode or VGA mode. **By factory default, Single Link is supported.**

- Note: By factory default, this setting is configured as "Auto Mode".

### Input Source Settings - DVI-I2 Mode

This OSD setting item is used to select the DVI-I2 port operating mode.

#### Settings as follows:

- DVI Mode = The port is locked to DVI-D mode, only accepting digital input. "Analog RGB 2" option in input source selection will be disabled.
- VGA Mode = The port is locked to VGA mode, only accepting analog input. "Digital 2" option in input source selection will be disabled.
- Auto Mode = The port can work in both DVI-D and VGA mode.

Note: For graphic cards that comes with DVI-I output, it is suggested to lock the operating mode to DVI mode or VGA mode. **By factory default, Dual Link is supported.**

- Note: By factory default, this setting is configured as "Auto Mode".

### Input Source Settings - Auto Source Select

Set to either 'Enable' or 'Disable'. Signal is automatically searched for and selected. If the Main Source signal is disconnected physically, the video controller will automatically search and select from the next item available in the list, such as; "Digital 1" (DVI), "Digital 2" (DVI), "Analog VGA1" (RGB/VGA), "Analog VGA2" (RGB/VGA), "Composite 1", "Composite 2", "Composite 3" (Composite Video) and "DisplayPort 1" (DP).

- Note: If all signals are physically disconnected from the unit, the Auto Source function will loop endlessly until it detects a valid signal to display. By factory default, this setting is configured as "Enable".
- Switch time for next source is ~5 sec. The longest auto detection time is ~1minute from 1st source to last source.

# OSD Menu Functions

## Input Source Settings - Rename Source

By factory default, every signal source input are named based on it's signal property as described in the previous functions, but with the rename source function you can rename these into more understandable descriptions like; "FRONT-CAMERA", "NIGHT RADAR" etc. When activated, a requester on screen similar to a standard keyboard layout will appear. Use the "(-) Brilliance (+)", "(<) Navigation (>)" and "MENU" touch buttons to enter and edit the new name. Below is an example for editing the "Source" input name. Only uppercased letters allowed.

The "|<" button will erase (backspace) the last character entered. Press "Enter" to save new name.

Yellow border around letter indicate selected character.



# OSD Menu Functions

## Image Settings

Lets you configure various visual preferences for any signal. The contents of these submenu are listed below.

### Image Settings - Auto Position

Will automatically fit the currently displayed full screen signal and center it based on the active area of the TFT display. This function relies on properties of the incoming signal.

- Note: This function will not try to scale or deform the image, so if the image looks stretched, please review the Management Setting/Scaling function later in this manual to adjust it on pixel level. Available for RGB/VGA mode only.

### Image Settings - Auto Color Balance

Choose between "Yes" or "No". This function will automatically adjust the color balance of the currently displayed full screen signal. This function will analyse the incoming signal strength for RGB values and adjust it for "best eye visibility". Colors are automatically calculated based on an overall coloring model to attempt a more true, relevant and correct look. In general, you should display an image on screen while performing this action that contains variations of Red, Green, Blue, Black, White, Gray colors to get the best optimal balance of the current signal. An example is a test pattern image, similar to the picture illustrated later in the manual (see "Service - Test Pattern")

- Note: Available for RGB/VGA mode only.

### Image Settings - Brightness

**\*Available in "Advanced" mode only**

Increase/decrease the black level saturation in real-time of the currently displayed full screen signal. Window overlays (PIP/PBP) and the OSD Menu overlay will be unaffected. A visual slider in the OSD menu will show the current value. This value adjusts the TFT panel's brightness by controlling the voltage feed.

- Note: Value adjustable from 0 to 255. 128 is factory default.

### Image Settings - Contrast

**\*Available in "Advanced" mode only**

Increase/decrease the contrast in real-time of the currently displayed full screen signal. Window overlays (PIP/PBP) and the OSD Menu overlay will be unaffected.

- Note: Value adjustable from 0 to 255. 128 is factory default.

### Image Settings - Saturation

**\*Available in "Advanced" only + Video Fullscreen**

Increase/decrease the overall video color saturation/color amount of the currently displayed full screen image (no effect on DVI/DP/VGA signals). Can be used if the incoming CVBS signal from older equipment (due to bad cables) appear to have a lack of strong colors or just to generally make the displayed image become more vivid. Note that this function can also make noisy color signals appear crisper/clearer if adjusted to gray scales.

- Note: Value adjustable from 0 to 255. 128 is factory default.

# OSD Menu Functions

## Image Settings - Hue

**\*Available in "Advanced" only + Video Fullscreen**

Allows you to adjust/shift the main color properties of all Red, Green, Blue and Yellow (unique hues) values. This can be useful for certain Composite Video sources (no effect on DVI/DP/VGA signals) whose output may have shifted or seems to be "out of phase", where for instance blue seems more dominant than green, red and yellow-ish colors. By using HUE one can shift the entire color range of all components left or right in the spectrum.

- Note: Value adjustable from 0 to 255. 128 is factory default.

## Image Settings - Sharpness

Increase/decrease the overall image sharpness. This affects the active display area, and applies to all signal inputs and window overlays (PIP/PBP). Use it to increase the visual quality of signals from older equipment or improve electronically weak signals.

- Note: Value adjustable from 0 to 24. 12 is factory default. Available in RGB/VGA, CVBS modes only.

## Image Settings - Display

Allows you to adjust DVI/DP/VGA signals Horizontally (left/right) and Vertically (up/down) within the TFT panel Active Area. If the incoming signal is "Analog VGA" (RGB/VGA) only, Clock and Phase can also be adjusted (if there seems to be a "waterfall / rolling bars" effect present in the active display area).

- Note: This function can move information in the image outside the visible TFT Active Area, so use caution when modifying this parameter. Try to determine the max end of borders (look at each corner) of the image before you proceed using this function.

## Image Settings - Display - H Position

### Settings as follows:

"H Position" = Move image within the TFT panel active area Horizontally (left/right), values from 0 to 100.

- Note: Factory Default value (50) is centered inside the active TFT panel area.

## Image Settings - Display - V Position

### Settings as follows:

"V.Position" = Move image within the TFT panel active area Vertically (up/down), values from 0 to 100.

- Note: Factory Default value (50) is centered inside the active TFT panel area.

## Image Settings - Display - Clock

Adjust the horizontal frequency (clock) of the analog signal to improve visibility of the entire image. When it is adjusted, you will notice that the image will appear to be stretched and might in some situations start to flicker/scroll, at which point you must reverse the last adjustment to stop it from flickering/scrolling anymore. This function can be used for older signals that is not automatically detected by the internal display controller.

To adjust the Clock and Phase to an optimal setting it is recommended to display an image with alternating white and black lines by stepped by 1 pixels either vertically or horizontally. It is suggested to use a dedicated and external test pattern while adjusting. Values from 0 to 100.

- Note: Available for RGB/VGA mode only.

## Image Settings - Display - Phase

Fine tune the data sampling position of the signal (impacts on image quality). This function will remove small transparent defects in typical characters where a portion seems to be more faint than the nearby black pixels. The faint pixels are always visible as a line from top to bottom (vertically). Note that this function is automatic and does not allow for manual values. It is suggested to use a dedicated and external test pattern while adjusting. Values from 0 to 63.

- Note: Available for RGB/VGA mode only.

## Image Settings - Display - Picture Direction

Choose between "0" and "180" degree rotation. 0 is normal view (Landscape), while 180 will rotate image to appear upside down (flipped vertically). Factory default setting is "0" (Landscape).

# OSD Menu Functions

## Image Settings - Video Setup

**\*Available when Video Fullscreen only**

Provides submenus where the following settings for Composite video signals are available:

### Image Settings - Video Setup - Main MADI mode

Motion Adaptive De-Interlacing. Motion adaptive de-interlacing is a pixel-based two-phase process. Phase 1 involves the detection of motion and the generation of a motion value for each pixel. These pixel motion values are used as a measure of the current "degree of motion". In Phase 2, the pixel motion values are used to select the appropriate de-interlacing technique. As a result, areas of an image that are not moving will be fully static (flicker free) and moving objects will have smooth edges.

Set to either "Normal", "Adaptive" or "OFF".

- Note: Default is OFF

### Image Settings - Video Setup - Noise Reduction

The media noise reduction block removes unwanted ringing and block noise from images that have undergone MPEG or JPEG compression and decompression. The two types of media noise that can be reduced are:

- Block Noise: MPEG encoders, in the presence of an almost flat area, can create a squared structure due to the discrete 8x8 squares that are used in the MPEG compression process. This creates a noticeable squared structure in the image. The process smoothens these square boundaries so they are not visible. The amount of smoothing is programmable between neighboring pixel values that will be smoothed. The amount of smoothing starts to decrease linearly from the maximum (defined by TO) to 0 (defined by 2 x TO) to avoid the hard switch effect of the smoothing applied.
- Mosquito Noise: This process smoothens checker box and discrete noise artifacts referred to as Mosquito Noise around large edge transitions caused by MPEG encoders.

This submenu will give you the following choices:

### Image Settings - Video Setup - Noise Reduction - Dynamic NR Mode

Dynamic NR (Noise Reduction) Mode can be set to either "High", "Medium", "Low", "Adaptive" or "OFF". This is the "strength" of how much noise to detect and automatically remove in order to enhance the overall image quality. The Block Noise process will be used.

- Note: Default is OFF

## OSD Menu Functions

### 4 Image Settings - Video Setup - Noise Reduction - MPEG NR Mode

MPEG NR (the generic coding of moving pictures and associated audio information) can be set to either "ON" or "OFF". This function will try to reduce noise as result from compressed/formatted MPEG video streams. This noise is often seen as larger blocks or containers of compressed pixels and is suitable to improve the visual performance of video feeds capable of outputting direct MPEG streams. The Block Noise process will be used.

- Note: Default is OFF

### 4 Image Settings - Video Setup - Noise Reduction - Sharpness Noise Coring

Adjust the clarity after Noise Reduction was applied to the video signal. Can be set to "High", "Medium", "Low", "Adaptive" or "OFF". The Mosquito Noise will be used.

- Note: Default is OFF

### 3 Image Settings - Video Setup - Film Mode

This function will analyze the resolution and frames per second information in the video feed and determine how to process/display each frame correctly (to avoid judder and staggering playback), also referenced as "pull down method". This option should be chosen to secure that the video feed is at maximum quality and performance. 2:2 is suitable for PAL/SECAM signals, while 2:3 is suitable for NTSC signals. 2:2-2:3 will try to conform to both standards and may be suited in some cases for mixed incoming video feeds. 3:2 film enables sequences of 24 Hz original film content and convert this to an output of 48 Hz or 72 Hz vertical refresh rate. This feature reduces the noticeable uneven judder seen on a 3:2 film sequence that is converted to 60 Hz vertical refresh rate.

Set to either; "2:2", "3:2", "3:2-2:2" or "OFF".

- Note: Default is OFF

### 3 Image Settings - Video Setup - DCDi

DCDi® BY Faroudja low-angle Diagonal interpolation. In addition to the advanced de-interlacing capabilities mentioned in the previous sections, further image enhancement is achieved by applying special processing to a moving low angle diagonal pattern in a video image. For motion video, the intra-field interpolation is done using the patented and highly acclaimed DCDi® (Directional Correlational De-Interlacing) algorithm by Faroudja®. Conventional Interpolation algorithms operate on the basis that the current pixel is related to the pixels above and below it. This is untrue of diagonal edges. Whenever an edge is not vertical, the way the current pixel depends on the angle of the edge is related to those diagonally above and below it. Hence, conventional vertical Interpolation algorithms work well on edges close to the horizontal and vertical directions. However, they will break down completely as the angles of edges become more diagonal, causing jagged edge artifacts. DCDi® by Faroudja computes and tracks the angles of edges and uses this information to optimally fill in the missing pixels, removing jagged edge artifacts.

Set to either "ON" or "OFF".

- Note: Default is OFF

# OSD Menu Functions

## Color Mode Settings

Lets you adjust the color temperature (Kelvin degrees) of the image. This applies to the Main Source signal. Window overlays (PIP/PBP) and the OSD Menu overlay will be unaffected. Lower values make the image appear warmer, while higher values will make it appear cooler. The contents of these submenus are listed below.

Illustration (does not appear in menu): The Kelvin color temperature scale (approximate and symbolic):



### |---2--- Color Mode Settings - Color Temperature

Set to either "9300K" (Cool, a blueish white), "8000K" (Neutral, a white close to natural light), "6500K" (Warm, a reddish white) or "User", (only available when Full Menu is active).

### |-----3----- Color Mode Settings - Color Temperature - User

Allows individual adjustment of Red, Green and Blue color gains. The selected setting will be saved for each signal input respectively.

- Note: Value adjustable from 0 to 255. 128 is factory default.

### |---2--- Color Mode Settings - Gamma

**\*Available in "Advanced" only + Video Fullscreen**

This will activate the stored gamma curve color compensation as well as the LED indicators or backlight brilliance used with ECDIS. Set to either "No Calibration", "Calibration VGA", "Calibration DVI" or "Calibration DisplayPort", where these represents the two storage locations for compensation data. When either of them are active, they will override the color temperature setting for the signal channel. Different signal channels can be set to different settings that will be saved.

This function is suitable for use with external equipment. Color temperature will be disabled.

- Note: Default is "No Calibration" with Gamma 2.2 and 140nits.

# OSD Menu Functions

## Multi-PIP Settings

Lets you adjust how the Picture-in-Picture (PIP) or Picture-by-Picture (PBP) display modes are set up. The default position of the rectangle is set to the upper left corner of the Active Display area. Note that this requires a valid incoming signal to be present in any of the "DVI", "DisplayPort", "VGA" or "Composite" inputs. The contents of these submenus are listed below.



Valid combinations of Picture-in-Picture (PIP) and Picture-by-Picture (PBP):  
 Gray = Same. **Red = Not possible.** **Green = OK.**

Main >	DVI1	DVI2	VGA1	VGA2	Composite1	Composite2	Composite3	DisplayPort
Second								
DVI1	Gray	Green	Red	Green	Green	Green	Green	Green
DVI2	Green	Gray	Green	Red	Green	Green	Green	Green
VGA1	Red	Green	Gray	Red	Green	Green	Green	Green
VGA2	Green	Red	Red	Gray	Green	Green	Green	Green
Composite1	Green	Green	Green	Green	Gray	Red	Red	Green
Composite2	Green	Green	Green	Green	Red	Gray	Red	Green
Composite3	Green	Green	Green	Green	Red	Red	Gray	Green
DisplayPort	Green	Green	Green	Green	Green	Green	Green	Gray

## Multi-PIP Settings - PIP Mode

### Settings as follows:

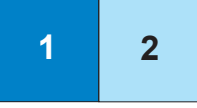
"PIP OFF" = Function is inactive and other settings can not be accessed.

<p>"PIP Child"</p> 	<p>The Secondary Source will be displayed in a small frame as an overlay over the Main Source signal. When this function is activated a new menu item will appear under "PIP Mode" called "PIP Display". Known as "Picture-In-Picture (PIP)".</p>
<p>"PIP Split"</p> 	<p>The Main Source and Secondary signal sources are shown side-by-side with the Main Source to the left and the Secondary Source to the right.  <b>Note:</b> Both sources will be stretched to fill screen. If aspect ratio is needed, consider PIP Wide function below, or set the sources to match 50% resolution of the native display. Example: If native TFT panel has 1920 x 1024 resolution, sources must be set to 960 (wide) x 512 (height) to appear correctly (aspect ratio).</p>
<p>"PIP Wide"</p> 	<p>The Main Source and Secondary signal sources are shown side-by-side in widescreen mode with the Main Source to the left and the Secondary to the right. Aspect Ratio of souce signals are preserved.</p>

- Note: Default is OFF

# OSD Menu Functions

## Multi-PIP Settings - PIP Display

**\*Available only when PIP Mode on**

When PIP Child mode is active, the size and position of the rectangle displaying the Secondary Source can be adjusted via the submenus below. Secondary Source needs to be a valid signal source.

## Multi-PIP Settings - PIP Display -- PIP Child Size

**Settings as follows:**

"PIP Size" = Adjust the full size (H and V) for Secondary Source, values from 1 to 9. Factory Default is 9.

"PIP H-Size" = Adjust the Horizontal size for Secondary Source, values from 0 to 20. Factory Default is 10.

"PIP V-Size" = Adjust the Vertical size for Secondary Source, values from 0 to 20. Factory Default is 10.

- Note: Default value for all 3 functions is 0.

## Multi-PIP Settings - PIP Position

When PIP Child mode is active, the size and position of the frame displaying the Secondary Source can be adjusted by means of submenus for size and position respectively below.

**Settings as follows:**

"PIP H-Position" = Adjust the Horizontal (left/right) position for Secondary Source, values from 0 to 100. Factory Default is 50.

"PIP V-Position" = Adjust the Vertical (up/down) position for Secondary Source, values from 0 to 100. Factory Default is 50.

## Multi-PIP Settings - Swap Source

Swaps the Main and Secondary source signals (if present) including adjustments you may have made, meaning that whatever is in Main Source will become the contents of the defined PIP rectangle, and contents of the PIP rectangle to become full screen.

- Note: You can also assign the Swap Source to the Hotkeys. Review "OSD Settings - Hot Key Assignment / Swap Source" section later in this manual.
- Note: Switch time between Main and Secondary source is ~5 sec.

When PIP mode is active, the picture appearance of the Secondary Source can be adjusted via the following settings:

**Settings as follows:**

- "Brightness" = Adjust the black level (brightness) of the Secondary Source, values from 0 to 255. Factory Default is 128.
- "Contrast" = Adjust the contrast of the Secondary Source, values from 0 to 255. Factory Default is 128.
- "Saturation" = Adjust the overall color intensity of the Secondary Source, values from 0 to 255. Factory Default is 128.
- "Hue" = Adjust the Hue color properties of the Secondary Source, values from 0 to 255. Factory Default is 128.
- "Sharpness" = Adjust the sharpness of the Secondary Source, values from 0 to 24. Factory Default is 12.

# OSD Menu Functions

## OSD Miscellaneous

Allows you to customize the visual appearance of the On Screen Display (OSD) menu, such as; position, transparency, time-out, assign hot keys, define access modes and save, load and recall favourite settings and more. The contents of these submenus are listed below.

### OSD Miscellaneous - OSD Position

#### Settings as follows:

"OSD H. Position" = Place the OSD menu overlay Horizontally (left/right), values from 0 to 255.

"OSD V. Position" = Place the OSD menu overlay Vertically (up/down), values from 0 to 255.

- Note: Default position of the OSD menu overlay is in the lower left corner of the of the Active Display area. Default value for both functions is 255.

### OSD Miscellaneous - Language

Available OSD language to be used for all text and warnings that may appear.

#### Settings as follows:

"Norsk" = Display OSD in Norwegian.

"English" = Display OSD in English.

"Français" = Display OSD in French.

"Deutsch" = Display OSD in German.

"Italiano" = Display OSD in Italian.

"日本語" = Display OSD in Japanese.

"簡體中文" = Display OSD in Simplified Chinese.

- Note: Current selected language is shown in green color. Default language is English.

### OSD Miscellaneous - Presets

Allows you to work with Memory Presets (Recall/Save/Load) for OSD menu settings and overlays. The contents of the submenu is listed below.

#### Settings as follows:

"Recall" = Reset back to factory defaults. Will override and restore all previous modified settings.

# OSD Menu Functions

## 3 OSD Miscellaneous - Preset Save - Save

Allows you to save current state of all function and values to user defined presets. The contents of the submenu is listed below.

### Settings as follows:

"User 1"	= Save all OSD settings to User 1 slot.
"User 2"	= Save all OSD settings to User 2 slot.
"User 3"	= Save all OSD settings to User 3 slot.
"User 4"	= Save all OSD settings to User 4 slot.
"User 5"	= Save all OSD settings to User 5 slot.

## 3 OSD Miscellaneous - Preset Save - Load

Allows you to load current state of all function and values to user defined presets. The contents of the submenu is listed below.

### Settings as follows:

"User 1"	= Load all OSD settings from User 1 slot.
"User 2"	= Load all OSD settings from User 2 slot.
"User 3"	= Load all OSD settings from User 3 slot.
"User 4"	= Load all OSD settings from User 4 slot.
"User 5"	= Load all OSD settings from User 5 slot.

## 2 OSD Miscellaneous - OSD Timeout (Sec)

Adjust the timeout in seconds that the OSD menu overlay is automatically exited and hidden from view including locking mode (see OSD Lock Mode/Advanced Mode on next page). This timeout is counted from last activity (navigation or adjusting parameters). The value is adjustable from 0 to 30 seconds.

- Note: Default timeout value is 10 seconds.

## 2 OSD Miscellaneous - OSD Transparent

Adjust the alpha blend also known as transparency of the OSD Menu overlay. It means that all signal inputs and PIP/PBP images show through the OSD Menu. It is used when important information on the display is necessary to be visible at all times.

- Note: Level adjustable from 0 to 7. 0 is factory default (no transparency/solid background color).

## OSD Miscellaneous - OSD Mode

Configuring the OSD Menu access based on most common functions to service/troubleshooting.

### Settings as follows:

- "Basic" = A few functions is not visible/available in this state. For most uses this is the preferred setting and are safe for the display functionality and continuous trusted operation on the unit.
- "Advanced" = All functions and parameters is visible/available in this state. Some of the settings adjusted could impact on display functionality and image quality. Only experienced and qualified personnel should access and change parameters when in this mode. Also, more technical details about signals, frequency will be available.
- "Service" = Only applicable for authorized service personnell. Key code is available from Hatteland Technology service network / HelpDesk.

- Note: Learn how to navigate and enter the correct code, by reading the "OSD Keycode / OSD Lock Mode" introduction section in the previous chapter.
- Note: When requesting "Advanced" mode from "Basic" mode, the user is required to enter a key code. This code is factory preset to "362". You can enter the code by using navigation and "MENU" to confirm. After a successful entering of the key code, the OSD menu will always be in this state during powered on. After a power off and on to the unit, the OSD Mode will be reverted back to "Basic" mode.

## OSD Miscellaneous - OSD Lock Mode **\*Available in "Advanced/Service" mode only**

To prevent accidental or unwanted user intervention, you can set the behaviour of how the OSD menu is accessible by the user including adjusting brightness via the "(-) Brilliance (+)" symbols. Normally by factory default accessible by pressing the "MENU" function on the front (user controls).

### Settings as follows:

- "Normal Mode" = Default accessible pop-up by touching the "MENU" symbol. For Non-ECDIS Compliant usage.
- "Menu Protect" = Ask for key code first (321) when the "MENU" symbol is touched on the front glass and before the OSD menu will appear. Required for ECDIS Compliance usage.
- "Full Protect" = When activated: You will have to press the "MENU" symbol for 5 seconds after which the key code requester will appear. Note that only the "MENU" symbol will activate the password request, all other touches on other symbols are ignored. After key code was entered and accepted, the OSD menu will appear in which case you have "x" seconds to use brilliance and power functions before all functions are deactivated again and returns to "Advanced Mode".

"x" value is defined as OSD Timeout value (see previous page).

- Note: Learn how to navigate and enter the correct code, by reading the "OSD Keycode / OSD Lock Mode" introduction section earlier in this chapter.

## OSD Miscellaneous - Hot Key Assignment \*Available in "Advanced/Service" mode only

|---2---

Assign a commonly used OSD menu function to the available touch enabled Hot Keys which are located on the front of unit (user controls). The following functions are available to assign and most of them have a negative and positive counting logic. All of these functions are described before and after this segment in the manual.

### Settings as follows (for both "Key 1" and "Key 2"):

**"OSD Language"** = Flip up/down through available languages (real-time changes).  
Reference in user manual: "OSD Settings / Language"

**"Test Pattern"** = Display the internal test image overriding any signal inputs. Both Hot Keys performs the same action.  
Reference in user manual: "Service Settings / Test Pattern"

**"Swap Source"** = Swap the Main Source and Secondary Source appearance. Both Hot Keys performs the same action.  
Reference in user manual: "Input Source Settings / Swap Source"

**"Graphic Scaling"** = Flip up/down through the scaling methods available.  
Reference in user manual: "Management Settings / Graphic Scaling / Graphic Scaling"

**"PIP Mode"** = Flip up/down through the PIP/PBP functions. Note: Only when PIP is active. Does not work for Fullscreen.  
Reference in user manual: "Multi-PIP Settings / PIP Mode"

**"Second Source"** = Flip up/down through the available signal sources (to PIP/PBP) for Second Source.  
Reference in user manual: "Multi-PIP Settings"

**"Main Source"** = Flip up/down through the available signal sources (to full screen) for Main Source.  
Reference in user manual: "Multi-PIP Settings"

**"PIP Child Size"** = Increase/Decrease the size of the Picture-In-Picture overlay.  
Reference in user manual: "Multi-PIP Settings / PIP Display / PIP Child Size"

**"Black Level"** = Increase/Decrease Brightness of the TFT panel (not backlight).  
Reference in user manual: "Image Settings / Brightness"

**"No Function"** = Nothing will be activated when user presses Hot Keys on the front. Both Hot Keys performs the same action.

- Note: Default Hot Keys are assigned to "No Function". You can assign different functions to "Key 1" and "Key 2".

## OSD Menu Functions

### |---2--- OSD Miscellaneous - OSD Key Outdoor \*Available in "Advanced/Service" mode only

To prevent accidental activation of Glass Display Control™ (GDC) touch functions, you can add an extra layer of security on how "sensitive" the touch detection operates. This applies for "MENU", "(-) Brilliance (+)" and "Power Off" functions. The OSD Key Outdoor function is especially effective if the unit is located where handheld UHF radio is commonplace or in a outside environment where rain drops could potentially trigger touch button functions. Note that this setting does not apply for fullscreen sized touch screen glasses.

The OSD Key Outdoor function has an added UHF protection for the uC (FW) Firmware version 0A27 and higher. When OSD Key Outdoor is ON, it will continuously detect for UHF frequencies and try to block these.

#### Settings as follows:

"Off" = All touch symbols operates normally. Factory Default setting.  
"On" = Touch symbols responds when you press and hold it for 5 seconds\*

\*Button presses will then operate normally until it has detected no button presses for 6 seconds (timeout period). After timeout period the OSD Key Outdoor setting will revert back to 5 seconds "press and hold" behaviour.

### |---2--- OSD Miscellaneous - Spectrum

Function only applicable for customized solutions.

- Note: Adjustable from 0 to 512. 0 is factory default.

### |---2--- OSD Miscellaneous - Keep OCM Mode \*Available in "Service" mode only

If signal input is not detected or disconnected, the unit will enter Deep Sleep Mode. In this mode, no MCC commands are processed if sent to unit. If MCC commands are needed, simply set the "Keep OCM Mode" function to "ON". The unit will now respond to MCC commands, even without any detected signal input or signal cable connected to unit.

Additionally, when function is chosen to be "Off", the GDC symbols (Brightness, GDC buttons) on front will automatically fade away after 10s inactivity detected on incoming signal (signal lost, connected computer shutdown, cable detached etc.). If function is chosen to "On", the GDC symbols will illuminate constantly.

#### Settings as follows:

"Off" = Factory Default setting, will enter Deep Sleep Mode. No MCC commands are processed (ignored). GDC symbols (Brightness, GDC buttons) on front will automatically fade away after 10s.  
"On" = Disables the Deep Sleep Mode and enables detection and processing of MCC commands. GDC Symbols will not fade away.

# OSD Menu Functions

## Management Settings

Allows you to adjust overall settings for interaction/communication for the unit, such as scaling, zoom, timing of signals, sensitivity for the touch control, VGA filter and Serial/Ethernet communication and more. The contents of these submenus are listed below.

### |---2--- Management Settings - Graphic Scaling \*Available in "Advanced" mode only

Allows you to scale the currently displayed full screen signal in various ways. The contents of the submenus is listed below.

### |-----3----- Management Settings - Graphic Scaling - Graphic Scaling

All scaling will performed from center of active display area and outwards in all directions.

#### Settings as follows:

- |                        |  |
|------------------------|--|
| "Full Screen"          | = Zoom current full screen signal to fill the entire active display area. Aspect ratio is ignored, which means that picture may appear distorted or stretched.   |
| "Fill to Aspect Ratio" | = Zoom current full screen signal to fill the entire active display area and preserve the aspect ratio. This means that you may notice black bars without any image information either on top/bottom or left/right of the centered image.  |
| "One To One"           | = Zoom current full screen signal to fill the entire active display area as 1:1 native pixel resolution. Example; if the incoming signal is a 800x600, on a 1600x1200 unit, the incoming signal will be shown 50% less in size and centered on screen. Aspect ratio is kept unchanged. |

### |-----3----- Management Settings - Scaling - Zoom

All zooming will performed from center of active display area and outwards in all directions.

#### Settings as follows:

- |        |   |
|--------|---|
| "Zoom" | = Zoom the current full screen signal horizontally and vertically in equal steps. Values from 0 to 100. |
|--------|---|

- Note: Values under or over 50, may cause blurry and unfocused imagery, since it overrides the external signal's 1.1 pixel information and properties. Factory Default value is 50.

## Management Settings - Graphic Scaling - Horizont Stretch

All stretching will performed from center of active display area and outwards in one direction.

### Settings as follows:

"Horizont Stretch" = Zoom/stretch current full screen signal in Horizontal direction only (left and right). Values from 0 to 100.

- Note: Values under or over 50, may cause blurry and unfocused imagery, since it overrides the external signal's 1.1 pixel information and properties. Factory Default value is 50.

## Management Settings - Graphic Scaling - Vertical Stretch

All stretch will performed from center of active display area and outwards in one direction.

### Settings as follows:

"Vertical Stretch" = Zoom/stretch current full screen signal in Vertical direction only (up and down). Values from 0 to 100.

- Note: Values under or over 50, may cause blurry and unfocused imagery, since it overrides the external signal's 1.1 pixel information and properties. Default value is 50.

## Management Settings - Auto Adjustment

Allows you to let the video controller always perform a Automatic Adjustment based on the detected properties in the incoming signal or when incoming signal sources changes it's properties real time. It will scale and position incoming signal sources that has changed since the last detection was executed successfully. Set to either "ON" or "OFF".

- Note: This function is the same as the manual function found in "Image Settings - Auto Position" earlier described. Default value is "OFF".

# OSD Menu Functions

## Management Settings - Unknown Timing Search \*Available in "Advanced" mode only

Use this if you are unable to find or detect the incoming full screen signal automatically (applies for Analog VGA and CVBS video signals only. A PIP or PBP configured signal is not supported). It may be a customized signal regarding resolution and refresh frequency. In these situations the custom signal sources can be searched upon or entered manually within the OSD menu and even stored conveniently. The contents of these submenus are listed below.

## Management Settings - Unknown Timing Search - Auto Mode

Try to determine the incoming signal by automatic detection routines which is based on a known list of properties for resolutions and frequency combinations that fall out, but between the most common industry standard set of resolutions/refresh frequencies.

### Settings as follows:

- |                |  |
|----------------|--|
| "Display Size" | = Force the Aspect Ratio to either to 4:3, 5:4, 1:1, 16:9 or 16:10   |
| "Execute"      | = Choose to produce timing table, update the "Blind Mode Data" and refresh the screen condition using the data of the timing table. If this procedure seem to fail, use the "Blind Mode" below to enter values manually. |

## Management Settings - Unknown Timing Search - Blind Mode

If you know the advanced properties of the incoming signal or want to troubleshoot a possible detected signal (that seem to have small deviations), you may try to adjust the values below and see the result in real time. These settings should be performed by a skilled technician or a individual that has the needed knowledge to do so. Internally these settings below are saved into a data register called "Timing Table".

### Settings as follows:

- |                   |   |
|-------------------|---|
| "H. Resolution"   | = Set the Horizontal resolution of the timing table.<br>Values from 0 to 2000.                        |
| "V. Resolution"   | = Set the Vertical resolution of the timing table.<br>Values from 0 to 2000.                          |
| "Total H. Line"   | = Set the Total Horizontal Lines of the timing table.<br>Values from 0 to 2000.                       |
| "H. Blank Pixels" | = Set the Horizontal Start of timing table,<br>(sync pulse + back porch). Values from 0 to 500.       |
| "V. Blank Pixels" | = Set the Vertical Start of timing table,<br>(sync pulse + back porch). Values from 0 to 500.         |
| "Execute"         | = Choose to produce timing table and refresh the screen condition using the data of the timing table. |

- Note: You may experience fast, slow flickering or sliding lines during adjustments. This is normal, and gives the indication that a different setting may have to be adjusted also, since all these functions are connected to each other in order to create a stable signal that the video controller can display correctly.

# OSD Menu Functions

## Management Settings - Unknown Timing Search - Save Timing

The current "Timing Table Data" that is currently visible in the "Blind Mode" or via the "Auto Mode" functions may now be saved to a user defined slot. Available save slots from 1 to 8. Saving "Time Table Data" may prove to be useful until the external equipment is either replaced or changed. If so, you should use the "Clear Timing" function below to remove any obsoleted "Timing Table Data" from time to time. Factory Default save slot is 1.

## Management Settings - Unknown Timing Search - Clear Timing

Will allow you to clear "Timing Table Data" currently saved / or not saved, based on the "Save Timing" function above. You may clear save slots 1 to 8. Factory Default slot is 1.

## Management Settings - GDC Sensitivity

**\*Available in "Advanced" mode only**

The touch enabled symbols known as GDC (Glass Display Control™) available on the front glass of the unit can be adjusted in sensitivity. It basically means that a small value requires a larger area to be covered longer over time, while a large value will require less smaller area to be covered in less time. If you set the value too low or too high, you may feel a difference in either increased responsiveness or the lack of such. By factory default the value is set to 150.

### Settings as follows:

"GDC Sensitivity" = Adjust values from 0 to 255.

- Note: Default is model dependent and set by factory. Note that the difference between 0 and 100 is minimal, as it is not suitable to go beyond a fair responsiveness that could cause accidental triggering of functions to occur by nearby objects touching the glass (i.e. rain drops for instance, washing glass with cloth).
- Caution: If the sensitivity value was set very low, you may experience an increased occurrence of non-responsiveness which also affects accessing the correct menu function in order to re-adjust this value. It is therefore suggested as a last resort solution to reset this value via SCOM (Serial/Ethernet Communication) functionality instead by sending a "Reset Factory Default" (or "Load User Default"+Slot Number, if available and previously stored by using "Save User Default"+Slot Number) commands if you are unable to navigate the OSD menu.

Please review the appropriate Technical User Manual located here:  
<https://www.hattelandtechnology.com/hubfs/pdfget/inb100018-6.htm>

## Management Settings - Filter

**\*Available in "Advanced" mode only**

Filter (applies for VGA1 signal input only) is a Signal Noise Reduction technique to enhance a possible weak or bad RGB/VGA signal. It will remove certain types of noise patterns typically apparent in close proximity of other electronic equipment with less or lack of proper shielding to prevent interference.

### Settings as follows:

"Filter" = Set to either "Enable" or "Disable".

- Note: Default is "Disable"

The unit allows for remote control (adjust brightness for example) and/or accessing internal information about the unit such as typenumber, serial number and more. To setup this feature, you first need to configure the Serial, Ethernet or USB protocol properly to match your external equipment specifications. The contents of the submenus is listed below.

### Settings as follows:

"RS232"	= Sets the internal communication to standard RS-232 protocol.
"2-wire RS-485"	= Sets the internal communication to RS-485 protocol (Half duplex).
"4-wire RS485/422"	= Sets the internal communication to RS-485/422 protocol (Full duplex).
"Address RS"	= Set the global unique channel/port ID for the unit (range 0-254).
"IP Address"	= IP can be found Automatically or you can set the IP address manually (xxx.xxx.xxx.xxx) for Ethernet protocol by choosing "Fixed IP".
"USB"	= Sets the internal communication to standard USB protocol.
"Enable RS232 FW" "Download"	= Allows Factory Firmware upgrade for the unit via RS-232 Serial Communication.

- Note: Default mode is "RS232" protocol.

A more detailed description of the SCOM (Serial/Ethernet Communication) can be found here:

<https://www.hattelandtechnology.com/hubfs/pdfget/inb100018-6.htm>

Review also the "Pinout Assignments" chapter in this manual for additional help during preparation and/or installation of external equipment intended to communicate with.

# OSD Menu Functions

## Management Settings - Power Plan

**\*Available in "Advanced" mode only**

This setting will allow you to control the power mode of USB/VGA out and Ethernet port in Power off mode.

### Settings as follows for "VGA Out/USB in Off Mode":

"Enable" = Enabled in power off mode.  
"Disable" = Disabled in power off mode.

- Note: Factory Default set to "Enable"

### Settings as follows for "LAN in OFF/Sleep Mode":

"Enable" = Enabled in power off mode.  
"Disable" = Disabled in power off mode.

- Note: Factory Default set to "Enable"

## Management Settings - Touch Power Enabled

**\*Available in "Advanced" mode only**

This setting will allow you to filter the signal processing from touch screen to reach the computer. For instance, if user only want touch screen to be active when DisplayPort signal is defined as Main Input, but disallows touch screen processing on other signal inputs, the non-touch screen enabled signal inputs would require the user to operate elements on screen either with keyboard, mouse or just for information purposes only with no user interaction possible via touch screen.

### Settings as follows:

"Always Active" = Touch is always enabled, even if there are no image on screen. Display unit may be powered off, but require power cable connected as well as a powered on computer. Signals from touch screen will still reach the computer.

"Any signal is On" = Touch is enabled when any input is active as Main Input.

"Select signal is On" = Following list and Choices available:

"Digital 1" = Touch is enabled only when DVI 1 is active as Main Input.  
"Digital 2" = Touch is enabled only when DVI 2 is active as Main Input.  
"Analog RGB 1" = Touch is enabled only when VGA is active as Main Input.  
"Analog RGB 2" = Touch is enabled only when VGA is active as Main Input.  
"Composite 1" = Touch is enabled only when Composite 1 is active as Main Input.  
"Composite 2" = Touch is enabled only when Composite 2 is active as Main Input.  
"Composite 3" = Touch is enabled only when Composite 3 is active as Main Input.  
"DisplayPort" = Touch is enabled only when DisplayPort is active as Main Input.

- Note: Factory Default set to "DisplayPort"

## OSD Menu Functions

### |---2--- Management Settings - External Power Button \*Available in "Advanced" mode only

This setting will allow you to manually enable the use of an external power button to turn off the Display unit. Please review the Pinout Assignments (Potmeter Control 9-pin DSUB MALE Connector) for connectivity.

#### Settings as follows:

"Enable" = Key press from External power button detection enabled.  
"Disable" = Key press from External power button detection disabled.

- Note: Factory Default set to "Disable"

### |---2--- Management Settings - DDC/CI Setting \*Available in "Advanced" mode only

This setting will allow user to enable and set which signal input where DDC/CI display control communication will occur. For more information about DDC/CI, please review the "Operation Advanced (DDC/CI) Control Overview" chapter in this manual.

The possible choices are: "Digital 1" (DVI), "Digital 2" (DVI), "Analog RGB 1" (VGA), "Analog RGB 2" (VGA), "DisplayPort 1" (DP) and "None".

- Note: Factory Default set to "None"

# OSD Menu Functions

## Service Settings

Will show various technical and unit related information, such as; Firmware versions, Elapsed Time, Internal Temperature, Fault Status and activation for the internal Test Pattern image useful for trouble-shooting. Some of these functions are static information while others are accessible. Whenever you are in contact with helpdesk or service, they might require you to read back some of these values in order to precisely pinpoint any problem/question you should have with the unit or its functionality.

### Information blocks as follows:

"Video Scaler Firmware"	= Displays the firmware version of the internal videocontroller. Example: "FW200001-0BV2"
"uC Firmware"	= Displays the firmware version of the touch enabled buttons. Example: "FW100002-0A12"
"Elapsed Time"	= Shows the time elapsed in hours since first-time power on. Example: "180"
"Current Temp"	= Shows the internal temperature measured by onchip sensor. Example: "+027.0 C", in Celcius Degrees.
"Fault Status"	= Will show detected Fault Status by measuring various internal values. Status is stated as either "OK" or "FAULT" <a href="#">Note: This item is only visible in "Advanced" menu mode.</a>

## Service - Fault Status

\*Available in "Service" mode only

Will show detected Fault Status by measuring various internal values during operation. Status is stated as either "OK" or "FAULT". The contents of this submenu is listed below.

### Fault Status as follows:

"NVRAM"	= Status for Non-volatile random-access memory, used to store parameters and settings.
"Ethernet"	= Status for Ethernet/LAN communication chip controller.
"GDC"	= Status for Glass Display Control™ (GDC) touch button controller.
"TMP Sensor"	= Status for internal temperature measured by on-chip sensor.
"Video Scaler"	= Status for on-board Digital Visual Interface graphics chip processor.

# OSD Menu Functions

## Service Settings - Test Pattern

Will show the internal test pattern with greyscales, colors and raster patterned boxes to check for deviations in the TFT panel/display controller behaviour. It is independent of any current resolution or specifications found in the signal inputs. The test pattern is generated internally in the display controller and is sent 1:1 directly to the TFT panel. It can be useful during trouble-shooting situations to determine the source of a display or connectivity problem regarding external equipment.

To activate this function, touch the "MENU" button.

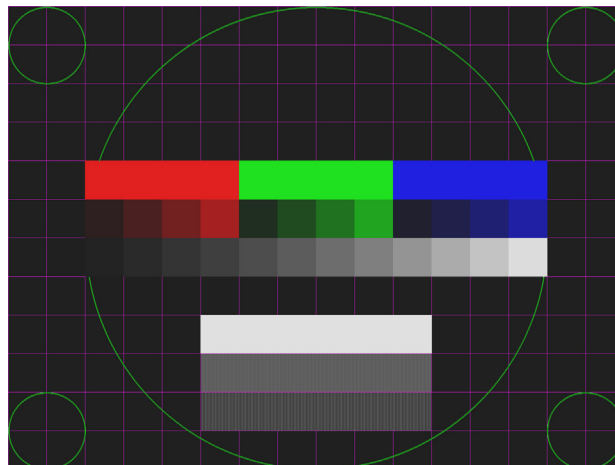

- Note: This function will not inform/report any deviations directly, you need to have the required technical expertise to interpret the test pattern displayed.

## Service Settings - Burn In

**\*Available in "Service" mode only**

Used to Warm up the panel with full-screen solid color. For internal testing purposes only. Please contact your nearest Hatteland Technology or Service Partner before using this setting.

## Service Settings - Smart ISP

**\*Available in "Service" mode only**

Used for Video Scaler firmware update. For experienced personell only, please contact Hatteland Technology or Service Partner for more information.

## Service Settings - Watchdog Test

**\*Available in "Service" mode only**

Used for internal testing only. For experienced personell only, please contact Hatteland Technology or Service Partner for more information.



# Specifications

# Specifications - JH 15T17 MMD-xRx-xxxx

All specifications are subject to change without prior notice!

## TFT Technology:

- High Quality TFT with LED Backlight Technology
- 15.0 inch viewable image size, Aspect Ratio 4:3
- TFT active-matrix liquid crystal panel

## TFT Characteristics:

- Native Resolution : 1024 x 768
- Pixel Pitch (RGB) : 0.297 (H) x 0.297 (V) mm
- Response Time : 8ms (typical), black to white
- Contrast Ratio : 1500:1 (typical)
- Light Intensity : 400 cd/m<sup>2</sup> (typical)
- Viewable Angle : +/- 85 deg. (Up/Down/Left/Right) (typical)
- Active Display Area : 304.1 (H) x 228.1 (V) mm
- Max Colors : 16.7 million

## Supported Signals:

### Resolutions:

- VGA : 640 x 480 (including 640 x 350)
- SVGA : 800 x 600 (including 720 x 400)
- XGA : 1024 x 768\*

\* Recommended for optimal picture quality

### Video Signals:

- Interlaced HDTV, NTSC, PAL and SECAM video
- Composite video

## Power Specifications:

### Multi-power Supply:

- 100-240V AC - 50/60Hz + 24 VDC

Note: You may connect either AC power or DC power or both. In case both sources are connected, power will be sourced from the AC input. If AC input is lost, there will be a uninterrupted switch-over to DC input.

### Power Consumption:

- Operating AC/DC: 75W (max)

## Physical Considerations:

- W:412.00 [16.22"] x H:345.00 [13.58"] x D:73.28 [2.89"] mm [inch]
- Weight: Approx. 5.5kg / 12.1lbs

## Signal Terminals:

- DVI-I IN : 2 x 29p DVI Female (or as VGA IN with adapter)\*
- DP1.2 IN : 1 x 20p DisplayPort (female)
- Comp. Video IN : 3 x BNC Connector (female)
- SCOM RS-422/485 : 2 x 5-pin Terminal Block 3.81, non-isolated+Buzzer
- SCOM USB : 1 x USB TYPE A Connector (female)
- SCOM Ethernet : 1 x RJ45 Connector
- SCOM RS-232 : 1 x 9p D-SUB (female)
- VGA OUT : 1 x 15p HD D-SUB (female) - Clone of VGA IN\*\*
- Potmeter/User : 1 x 9p D-SUB (male)  
(Potentiometer IN, +5VDC OUT, BRT +/- IN)
- If Touch Screen : 1 x 9p D-SUB (female)
- AC Power IN : 1 x Std IEC Inlet
- DC Power IN : 1 x 2-pin Terminal Block 5.08

\* DVI-I Port #1 as VGA IN also acts as clone to VGA Signal Out (buffered).

\*\*Tested at recommended resolutions. The VGA output signal (buffered) is at same resolution and sync as the VGA input. The output is working even if the display unit is turned off, but power cable/supply must be connected/provided.

### Note for DVI and VGA signal inputs:

DVI-I #1, DVI-D #1 and VGA #1 is Single Link.  
DVI-I #2, DVI-D #2 and VGA #2 is Dual Link.

## User Controls:

### On front bezel - Keypad control (IP66) xRx-xxAx models:

- Power On/Off and On Screen Display Menu (push button)
- Brightness Control (up/down - push buttons)
- Hotkeys (left/right - push buttons)
- Mode Status Red/Green Illuminated LED-Ring Indicator

### On front bezel - Potmeter control (IP66) xRx-xxBx models:

- Power On/Off and On Screen Display Menu (push button)
- Brightness Control (rotary control)
- Hotkeys (left/right - push buttons)
- Mode Status Red/Green Illuminated LED-Ring Indicator
- Buzzer

## Environmental Considerations:

- Operating : Temperature -15°C to +55°C
- Storage : Temperature -20°C to +60°C
- Humidity : Up to 95% (Operating / Storage)
- IP-Rating Protection : IP66 front - IP20 rear (EN60529).
- Compass Safe Distance : Standard: 110cm - Steering: 70cm

### Lifetime Considerations:

Even though the test conditions for bridge units provide for a maximum operating temperature of 55°C, continuous operation of all electronic components should, if possible, take place at ambient temperatures of only 25°C. This is a necessary prerequisite for long life and low service costs.

## Available Accessories:

- JH 15TBR STD-B1 : Mounting Bracket
- JH 15TRO STD-A1 : Rotary Bracket
- JH 15TSV STD-A1 : Sun Visor
- JH 15VED STD-A1 : VESA Adapter 75/100mm
- JH 15TAP STD-A1 : 15" Adapter Frame to 19" Rack
- JH 15TAP STD-B1 : 15" Adapter Frame to 17" CRT cut-out
- JH 15TWC STD-A1 : Water Cover

## Factory Options:

- Resistive\* or Capacitive Touch Screen
- Optical Bonding Technology
- Keypad only or Keypad+Potmeter+Buzzer controls

\*Can not be combined with Optical Bonding Technology

## APPROVALS & CERTIFICATES

These products have been tested / type approved by the following classification societies: \*=PENDING

- |  |  |   |                                       |                                       |
|--|--|---|---------------------------------------|---------------------------------------|
| <b>IEC 60945 4th</b> (EN 60945:2002)                     | <b>IACS E10</b>                            | <b>EN55024</b>                            | <b>EN55022, Class A</b>               | <b>EU RO MR</b> - Mutual Recognition* |
| <b>DNV GL</b> - Det Norske Veritas / Germanischer Lloyd* | <b>LRS</b> - Lloyd's Register of Shipping* | <b>ABS</b> - American Bureau of Shipping* | <b>ClassNK</b> - Nippon Kaiji Kyokai* |                                       |
| <b>CCS</b> - China Classification Society                | <b>KR</b> - Korean Register of Shipping*   | <b>BV</b> - Bureau Veritas*               |                                       |                                       |

# Specifications - JH 19T14 MMD-xRx-Sxxx (Slim Frame Model)

All specifications are subject to change without prior notice!

## TFT Technology:

- High Quality TFT with LED Backlight Technology
- 19.0 inch viewable image size, Aspect Ratio 5:4
- TFT active-matrix liquid crystal panel
- MVA (Multi-domain Vertical Alignment) LCD Technology

## TFT Characteristics:

- Native Resolution : 1280 x 1024
- Pixel Pitch (RGB) : 0.294 (H) x 0.294 (V) mm
- Response Time : 35ms (typical), "black" to "white"
- Contrast Ratio : 1500:1 (typical)
- Light Intensity : 350 cd/m<sup>2</sup> (typical)
- Viewable Angle : +/- 85 deg. (typical) (Up/Down/Left/Right)
- Active Display Area : 376.32 (H) x 301.056 (V) mm
- Max Colors : 16.7 million

## Supported Signals:

### Resolutions:

- VGA : 640 x 480 (including 640 x 350)
- SVGA : 800 x 600 (including 720 x 400)
- XGA : 1024 x 768
- SXGA : 1280 x 1024\*

\* Recommended for optimum picture quality. (60 Hz only)

### Video Signals:

- Interlaced HDTV, NTSC, PAL and SECAM video
- Composite video

## Power Specifications:

### Multi-power Supply:

- 100-240V AC - 50/60Hz + 24 VDC

Note: You may connect either AC power or DC power or both. In case both sources are connected, power will be sourced from the AC input. If AC input is lost, there will be a uninterrupted switch-over to DC input.

### Power Consumption:

- Operating AC/DC: 75W (Max)

## Physical Considerations:

- W:460.00 [18.11"] x H:400.00 [15.75"] x D:82.00 [3.23"] mm [inch]
- Weight: Approx. 7.0kg / 15.4lbs

## Signal Terminals:

- DVI-I IN : 2 x 29p DVI Female (or as VGA IN with adapter)\*
- DP1.2 IN : 1 x 20p DisplayPort (female)
- Comp. Video IN : 3 x BNC Connector (female)
- SCOM RS-422/485 : 2 x 5-pin Terminal Block 3.81, non-isolated+Buzzer
- SCOM USB : 1 x USB TYPE A Connector (female)
- SCOM Ethernet : 1 x RJ45 Connector
- SCOM RS-232 : 1 x 9p D-SUB (female)
- VGA OUT : 1 x 15p HD D-SUB (female) - Clone of VGA IN\*\*
- Potmeter/User : 1 x 9p D-SUB (male)  
(Potentiometer IN, +5VDC OUT, BRT +/- IN)
- If Touch Screen : 1 x 9p D-SUB (female)
- AC Power IN : 1 x Std IEC Inlet
- DC Power IN : 1 x 2-pin Terminal Block 5.08

\* DVI-I Port #1 as VGA IN also acts as clone to VGA Signal Out (buffered).

\*\*Tested at recommended resolutions. The VGA output signal (buffered) is at same resolution and sync as the VGA input. The output is working even if the display unit is turned off, but power cable/supply must be connected/provided.

### Note for DVI and VGA signal inputs:

DVI-I #1, DVI-D #1 and VGA #1 is Single Link.  
DVI-I #2, DVI-D #2 and VGA #2 is Dual Link.

## User Controls:

### On front bezel - Keypad control (IP66) xRx-xxAx models:

- Power On/Off and On Screen Display Menu (push button)
- Brightness Control (up/down - push buttons)
- Hotkeys (left/right - push buttons)
- Mode Status Red/Green Illuminated LED-Ring Indicator

### On front bezel - Potmeter control (IP66) xRx-xxBx models:

- Power On/Off and On Screen Display Menu (push button)
- Brightness Control (rotary control)
- Hotkeys (left/right - push buttons)
- Mode Status Red/Green Illuminated LED-Ring Indicator
- Buzzer

## Environmental Considerations:

- Operating : Temperature -15°C to +55°C
- Storage : Temperature -20°C to +60°C
- Humidity : Up to 95% (Operating / Storage)
- IP-Rating Protection : IP66 front - IP20 rear (EN60529).
- Compass Safe Distance : Standard: 110cm - Steering: 70cm

### Lifetime Considerations:

Even though the test conditions for bridge units provide for a maximum operating temperature of 55°C, continuous operation of all electronic components should, if possible, take place at ambient temperatures of only 25°C. This is a necessary prerequisite for long life and low service costs.

## Available Accessories:

- JH 19TWC STD-C1 : Water Cover
- JH 19TBR STD-B1 : Mounting Bracket
- JH MMDBR STD-A1 : Mounting Bracket
- JH MMDRO STD-A1 : Rotary Bracket
- JH 19VED STD-B1 : VESA Adapter 75/100mm
- JH 19TSV STD-B1 : Sun Visor
- JH 17TAP STD-A1 : Adapter frame for 19" RACK

## Factory Options:

- Resistive\* or Capacitive Touch Screen
- Color Calibrated models (ECDIS)
- Optical Bonding Technology
- Keypad only or Keypad+Potmeter+Buzzer controls

\*Can not be combined with Optical Bonding Technology

## APPROVALS & CERTIFICATES

These products have been tested / type approved by the following classification societies: \*=PENDING

- |  |  |                             |   |                                       |
|--|--|-----------------------------|---|---------------------------------------|
| <b>IEC 60945 4th</b> (EN 60945:2002)                     | <b>IACS E10</b>                            | <b>EN55024</b>              | <b>EN55022, Class A</b>                   | <b>EU RO MR</b> - Mutual Recognition* |
| <b>DNV GL</b> - Det Norske Veritas / Germanischer Lloyd* | <b>LRS</b> - Lloyd's Register of Shipping* | <b>BV</b> - Bureau Veritas* | <b>ABS</b> - American Bureau of Shipping* | <b>ClassNK</b> - Nippon Kaiji Kyokai* |
| <b>CCS</b> - China Classification Society                | <b>KR</b> - Korean Register of Shipping*   |                             |   |                                       |

# Specifications - JH 19T14 MMD-xRx-xxxx

All specifications are subject to change without prior notice!

## TFT Technology:

- High Quality TFT with LED Backlight Technology
- 19.0 inch viewable image size, Aspect Ratio 5:4
- TFT active-matrix liquid crystal panel
- MVA (Multi-domain Vertical Alignment) LCD Technology

## TFT Characteristics:

- Native Resolution : 1280 x 1024
- Pixel Pitch (RGB) : 0.294 (H) x 0.294 (V) mm
- Response Time : 35ms (typical), "black" to "white"
- Contrast Ratio : 1500:1 (typical)
- Light Intensity : 350 cd/m<sup>2</sup> (typical)
- Viewable Angle : +/- 85 deg. (typical) (Up/Down/Left/Right)
- Active Display Area : 376.32 (H) x 301.056 (V) mm
- Max Colors : 16.7 million

## Supported Signals:

### Resolutions:

- VGA : 640 x 480 (including 640 x 350)
- SVGA : 800 x 600 (including 720 x 400)
- XGA : 1024 x 768
- SXGA : 1280 x 1024\*

\* Recommended for optimum picture quality. (60 Hz only)

### Video Signals:

- Interlaced HDTV, NTSC, PAL and SECAM video
- Composite video

## Power Specifications:

### Power Supply Options:

- Multi-Power : 100-240V AC - 50/60Hz + 24 VDC\*
- Single Power : 100-240V AC - 50/60Hz

\*You may connect either AC power or DC power or both. In case both sources are connected, power will be sourced from the AC input. If AC input is lost, there will be a uninterrupted switch-over to DC input.

### Power Consumption:

- Operating AC/DC: 75W (Max)

## Physical Considerations:

- W:483.00 [19.02"] x H:444.00 [17.48"] x D:82.00 [3.23"] mm [inch]
- Weight: Approx. 7.6kg / 16.7lbs

## Signal Terminals:

- DVI-I IN : 2 x 29p DVI Female (or as VGA IN with adapter)\*
- DP1.2 IN : 1 x 20p DisplayPort (female)
- Comp. Video IN : 3 x BNC Connector (female)
- SCOM RS-422/485 : 2 x 5-pin Terminal Block 3.81, non-isolated+Buzzer
- SCOM USB : 1 x USB TYPE A Connector (female)
- SCOM Ethernet : 1 x RJ45 Connector
- SCOM RS-232 : 1 x 9p D-SUB (female)
- VGA OUT : 1 x 15p HD D-SUB (female) - Clone of VGA IN\*\*
- Potmeter/User : 1 x 9p D-SUB (male)  
(Potentiometer IN, +5VDC OUT, BRT +/- IN)
- If Touch Screen : 1 x 9p D-SUB (female)
- AC Power IN : 1 x Std IEC Inlet
- If DC Power IN : 1 x 2-pin Terminal Block 5.08

\* DVI-I Port #1 as VGA IN also acts as clone to VGA Signal Out (buffered).

\*\*Tested at recommended resolutions. The VGA output signal (buffered) is at same resolution and sync as the VGA input. The output is working even if the display unit is turned off, but power cable/supply must be connected/provided.

### Note for DVI and VGA signal inputs:

DVI-I #1, DVI-D #1 and VGA #1 is Single Link.  
DVI-I #2, DVI-D #2 and VGA #2 is Dual Link.

## User Controls:

### On front bezel - Keypad control (IP66) xRx-xxAx models:

- Power On/Off and On Screen Display Menu (push button)
- Brightness Control (up/down - push buttons)
- Hotkeys (left/right - push buttons)
- Mode Status Red/Green Illuminated LED-Ring Indicator

### On front bezel - Potmeter control (IP66) xRx-xxBx models:

- Power On/Off and On Screen Display Menu (push button)
- Brightness Control (rotary control)
- Hotkeys (left/right - push buttons)
- Mode Status Red/Green Illuminated LED-Ring Indicator
- Buzzer

## Environmental Considerations:

- Operating : Temperature -15°C to +55°C
- Storage : Temperature -20°C to +60°C
- Humidity : Up to 95% (Operating / Storage)
- IP-Rating Protection : IP66 front - IP20 rear (EN60529).
- Compass Safe Distance : Standard: 110cm - Steering: 70cm

### Lifetime Considerations:

Even though the test conditions for bridge units provide for a maximum operating temperature of 55°C, continuous operation of all electronic components should, if possible, take place at ambient temperatures of only 25°C. This is a necessary prerequisite for long life and low service costs.

## Available Accessories:

- JH MMDBR STD-A1 : Mounting Bracket
- JH 19BRD STD-A1 : Mounting Bracket EN60945 Tested
- JH MMDRO STD-A1 : Rotary Bracket
- JH 19TSV STD-A1 : Sun Visor
- JH 19VED STD-A1 : VESA Adapter 75/100mm
- JH 19TAP STD-A1 : 21" CRT Adapter frame
- JH 19TAP STD-B1 : 21" CRT Custom Adapter frame
- JH 19TAP STD-A2 : 20" TFT Adapter frame
- JH 19TWC STD-B1 : Water Cover

## Factory Options:

- Resistive\* or Capacitive Touch Screen
- Color Calibrated models (ECDIS)
- Optical Bonding Technology
- Multi-Power Input Model or Single AC Power Input Model
- Keypad only or Keypad+Potmeter+Buzzer controls

\*Can not be combined with Optical Bonding Technology

## APPROVALS & CERTIFICATES

These products have been tested / type approved by the following classification societies: \* = PENDING

IEC 60945 4th (EN 60945:2002)

IACS E10

EN55024

EN55022, Class A

EU RO MR - Mutual Recognition\*

DNV GL - Det Norske Veritas / Germanischer Lloyd\*

LRS - Lloyd's Register of Shipping\*

ABS - American Bureau of Shipping\*

CCS - China Classification Society

KR - Korean Register of Shipping\*

BV - Bureau Veritas\*

ClassNK - Nippon Kaiji Kyokai\*

# Specifications - JH 20T17 MMD-xRx-xxxx

All specifications are subject to change without prior notice!

## TFT Technology:

- High Quality TFT with LED Backlight Technology
- 20.1 inch viewable image size
- a-Si TFT (Thin Film Transistor) Active Matrix, RGB Vertical Stripe

## TFT Characteristics:

- Pixel Number : 1600 x 1200
- Pixel Pitch (RGB) : 0.255 (H) x 0.255 (V) mm
- Response Time : 30 ms (typical), rise + fall
- Contrast Ratio : 1000:1 (typical)
- Light Intensity : 260 cd/m2 (typical)
- Viewable Angle : +/- 85 deg. (typical) (Up/Down/Left/Right)
- Active Display Area : 408.0 (H) x 306.0 (V) mm
- Max Colors : 16.7 millions

## Supported Signals:

### Resolutions:

- VGA : 640 x 480 (including 640 x 350)
- SVGA : 800 x 600 (including 720 x 400)
- XGA : 1024 x 768
- SXGA : 1280 x 1024
- UXGA : 1600 x 1200\*
- FHD : 1920 x 1080
- WUXGA : 1920 x 1200

\* Recommended for optimal picture quality

### Video Signals:

- Interlaced HDTV, NTSC, PAL and SECAM video
- Composite video

## Power Specifications:

### Multi-power Supply:

- 100-240V AC - 50/60Hz + 24 VDC

Note: You may connect either AC power or DC power or both. In case both sources are connected, power will be sourced from the AC input. If AC input is lost, there will be a uninterrupted switch-over to DC input.

### Power Consumption:

- Operating AC/DC: 75W (Max)

## Physical Considerations:

- W:534.00 [21.02"] x H:481.00 [18.94"] x D:87.00 [3.43"] mm [inch]
- Weight: Approx. 10.5kg / 23.1lbs

## Signal Terminals:

- DVI-I IN : 2 x 29p DVI Female (or as VGA IN with adapter)\*
- DP1.2 IN : 1 x 20p DisplayPort (female)
- Comp. Video IN : 3 x BNC Connector (female)
- SCOM RS-422/485 : 2 x 5-pin Terminal Block 3.81, non-isolated+Buzzer
- SCOM USB : 1 x USB TYPE A Connector (female)
- SCOM Ethernet : 1 x RJ45 Connector
- SCOM RS-232 : 1 x 9p D-SUB (female)
- VGA OUT : 1 x 15p HD D-SUB (female) - Clone of VGA IN\*\*
- Potmeter/User : 1 x 9p D-SUB (male)  
(Potentiometer IN, +5VDC OUT, BRT +/- IN)
- If Touch Screen : 1 x 9p D-SUB (female)
- AC Power IN : 1 x Std IEC Inlet
- DC Power IN : 1 x 2-pin Terminal Block 5.08

\* DVI-I Port #1 as VGA IN also acts as clone to VGA Signal Out (buffered).

\*\*Tested at recommended resolutions. The VGA output signal (buffered) is at same resolution and sync as the VGA input. The output is working even if the display unit is turned off, but power cable/supply must be connected/provided.

### Note for DVI and VGA signal inputs:

DVI-I #1, DVI-D #1 and VGA #1 is Single Link.  
DVI-I #2, DVI-D #2 and VGA #2 is Dual Link.

## User Controls:

### On front bezel - Keypad control (IP66) xRx-xxAx models:

- Power On/Off and On Screen Display Menu (push button)
- Brightness Control (up/down - push buttons)
- Hotkeys (left/right - push buttons)
- Mode Status Red/Green Illuminated LED-Ring Indicator

### On front bezel - Potmeter control (IP66) xRx-xxBx models:

- Power On/Off and On Screen Display Menu (push button)
- Brightness Control (rotary control)
- Hotkeys (left/right - push buttons)
- Mode Status Red/Green Illuminated LED-Ring Indicator
- Buzzer

## Environmental Considerations:

- Operating : Temperature -15°C to +55°C
- Storage : Temperature -20°C to +60°C
- Humidity : Up to 95% (Operating / Storage)
- IP-Rating Protection : IP66 front - IP20 rear (EN60529).
- Compass Safe Distance : Standard: 65cm - Steering: 40cm

### Lifetime Considerations:

Even though the test conditions for bridge units provide for a maximum operating temperature of 55°C, continuous operation of all electronic components should, if possible, take place at ambient temperatures of only 25°C. This is a necessary prerequisite for long life and low service costs.

## Available Accessories:

- JH MMDBR STD-A1 : Mounting Bracket
- JH MMDRO STD-A1 : Rotary Bracket
- JH 20TSV STD-B1 : Sun Visor
- JH 20VED STD-A1 : VESA Adapter 75/100mm
- JH 20TWC STD-B1 : Water Cover

## Factory Options:

- Capacitive Touch Screen
- Optical Bonding Technology
- Color Calibrated models (ECDIS)
- Keypad only or Keypad+Potmeter+Buzzer controls

## APPROVALS & CERTIFICATES

These products have been tested / type approved by the following classification societies: \*=PENDING

- |  |  |   |                                       |                                       |
|--|--|---|---------------------------------------|---------------------------------------|
| <b>IEC 60945 4th</b> (EN 60945:2002)                     | <b>IACS E10</b>                            | <b>EN55024</b>                            | <b>EN55022, Class A</b>               | <b>EU RO MR</b> - Mutual Recognition* |
| <b>DNV GL</b> - Det Norske Veritas / Germanischer Lloyd* | <b>LRS</b> - Lloyd's Register of Shipping* | <b>ABS</b> - American Bureau of Shipping* | <b>ClassNK</b> - Nippon Kaiji Kyokai* |                                       |
| <b>CCS</b> - China Classification Society                | <b>KR</b> - Korean Register of Shipping*   | <b>BV</b> - Bureau Veritas*               |                                       |                                       |

# Specifications - JH 23T14 MMD-xRx-xxxx

All specifications are subject to change without prior notice!

## TFT Technology:

- High Quality TFT with LED Backlight Technology
- 23.1 inch viewable image size
- TFT active-matrix liquid crystal panel
- MVA (Multi-domain Vertical Alignment) LCD Technology

## TFT Characteristics:

- Pixel Number : 1600 x 1200
- Pixel Pitch (RGB) : 0.294 (H) x 0.294 (V) mm
- Response Time : 12ms (typ) black-white-black or 8ms gray to gray
- Contrast Ratio : 600:1 (typical)
- Light Intensity : 500 cd/m2 (typical)
- Viewable Angle : +/- 85 deg. (typical) (Up/Down/Left/Right)
- Active Display Area : 470.4 (H) x 352.8 (V) mm
- Max Colors : 16.7 millions

## Supported Signals:

### Resolutions:

- VGA : 640 x 480 (including 640 x 350)
- SVGA : 800 x 600 (including 720 x 400)
- XGA : 1024 x 768
- SXGA : 1280 x 1024
- UXGA : 1600 x 1200\*
- FHD : 1920 x 1080
- WUXGA : 1920 x 1200

\* Recommended for optimal picture quality

### Video Signals:

- Interlaced HDTV, NTSC, PAL and SECAM video
- Composite video

## Power Specifications:

### Multi-power Supply:

- 100-240V AC - 50/60Hz + 24 VDC

Note: You may connect either AC power or DC power or both. In case both sources are connected, power will be sourced from the AC input. If AC input is lost, there will be a uninterrupted switch-over to DC input.

### Power Consumption:

- Operating AC/DC: 156W (max)

## Physical Considerations:

- W: 584.00 [22.99] x H: 534.00 [21.02] x D: 85.00 [3.35] mm [inch]
- Weight: Approx. 13.5kg / 29.7lbs

## Signal Terminals:

- DVI-I IN : 2 x 29p DVI Female (or as VGA IN with adapter)\*
- DP1.2 IN : 1 x 20p DisplayPort (female)
- Comp. Video IN : 3 x BNC Connector (female)
- SCOM RS-422/485 : 2 x 5-pin Terminal Block 3.81, non-isolated+Buzzer
- SCOM USB : 1 x USB TYPE A Connector (female)
- SCOM Ethernet : 1 x RJ45 Connector
- SCOM RS-232 : 1 x 9p D-SUB (female)
- VGA OUT : 1 x 15p HD D-SUB (female) - Clone of VGA IN\*\*
- Potmeter/User : 1 x 9p D-SUB (male)  
(Potentiometer IN, +5VDC OUT, BRT +/- IN)
- If Touch Screen : 1 x 9p D-SUB (female)
- AC Power IN : 1 x Std IEC Inlet
- DC Power IN : 1 x 2-pin Terminal Block 5.08

\* DVI-I Port #1 as VGA IN also acts as clone to VGA Signal Out (buffered).

\*\*Tested at recommended resolutions. The VGA output signal (buffered) is at same resolution and sync as the VGA input. The output is working even if the display unit is turned off, but power cable/supply must be connected/provided.

### Note for DVI and VGA signal inputs:

DVI-I #1, DVI-D #1 and VGA #1 is Single Link.  
DVI-I #2, DVI-D #2 and VGA #2 is Dual Link.

## User Controls:

### On front bezel - Keypad control (IP66) xRx-xxAx models:

- Power On/Off and On Screen Display Menu (push button)
- Brightness Control (up/down - push buttons)
- Hotkeys (left/right - push buttons)
- Mode Status Red/Green Illuminated LED-Ring Indicator

### On front bezel - Potmeter control (IP66) xRx-xxBx models:

- Power On/Off and On Screen Display Menu (push button)
- Brightness Control (rotary control)
- Hotkeys (left/right - push buttons)
- Mode Status Red/Green Illuminated LED-Ring Indicator
- Buzzer

## Environmental Considerations:

- Operating : Temperature -15°C to +55°C
- Storage : Temperature -20°C to +60°C
- Humidity : Up to 95% (Operating / Storage)
- IP-Rating Protection : IP66 front - IP20 rear (EN60529).
- Compass Safe Distance : Standard: 110cm - Steering: 70cm

### Lifetime Considerations:

Even though the test conditions for bridge units provide for a maximum operating temperature of 55°C, continuous operation of all electronic components should, if possible, take place at ambient temperatures of only 25°C. This is a necessary prerequisite for long life and low service costs.

## Available Accessories:

- JH 23TBR T01-A1 : Mounting Bracket
- JH 23BRD STD-A1 : Mounting Bracket EN6095 Tested
- JH MMDRO STD-A1 : Rotary Bracket
- JH 23TSV STD-A1 : Sun Visor
- JH 23VED STD-A1 : VESA Adapter 75/100mm
- JH 23TWC STD-A1 : Water Cover

## Factory Options:

- Capacitive\* Touch Screen
- Optical Bonding Technology
- Color Calibrated models (ECDIS)
- Keypad only or Keypad+Potmeter+Buzzer controls

\*Note that touch screen additionally require factory default optical bonding technology

## APPROVALS & CERTIFICATES

These products have been tested / type approved by the following classification societies: \*=PENDING

IEC 60945 4th (EN 60945:2002)

IACS E10

EN55024

EN55022, Class A

EU RO MR - Mutual Recognition\*

DNV GL - Det Norske Veritas / Germanischer Lloyd\*

LRS - Lloyd's Register of Shipping\*

ABS - American Bureau of Shipping\*

CCS - China Classification Society

KR - Korean Register of Shipping\*

BV - Bureau Veritas\*

ClassNK - Nippon Kaiji Kyokai\*



# Technical Drawings

# Technical Drawings - JH 15T17 MMD-xRx-xxxx

Dimensions might be shown with or without decimals and indicated as mm [inches]. Tolerance on drawings is +/- 1mm. For accurate measurements, check relevant DWG file.

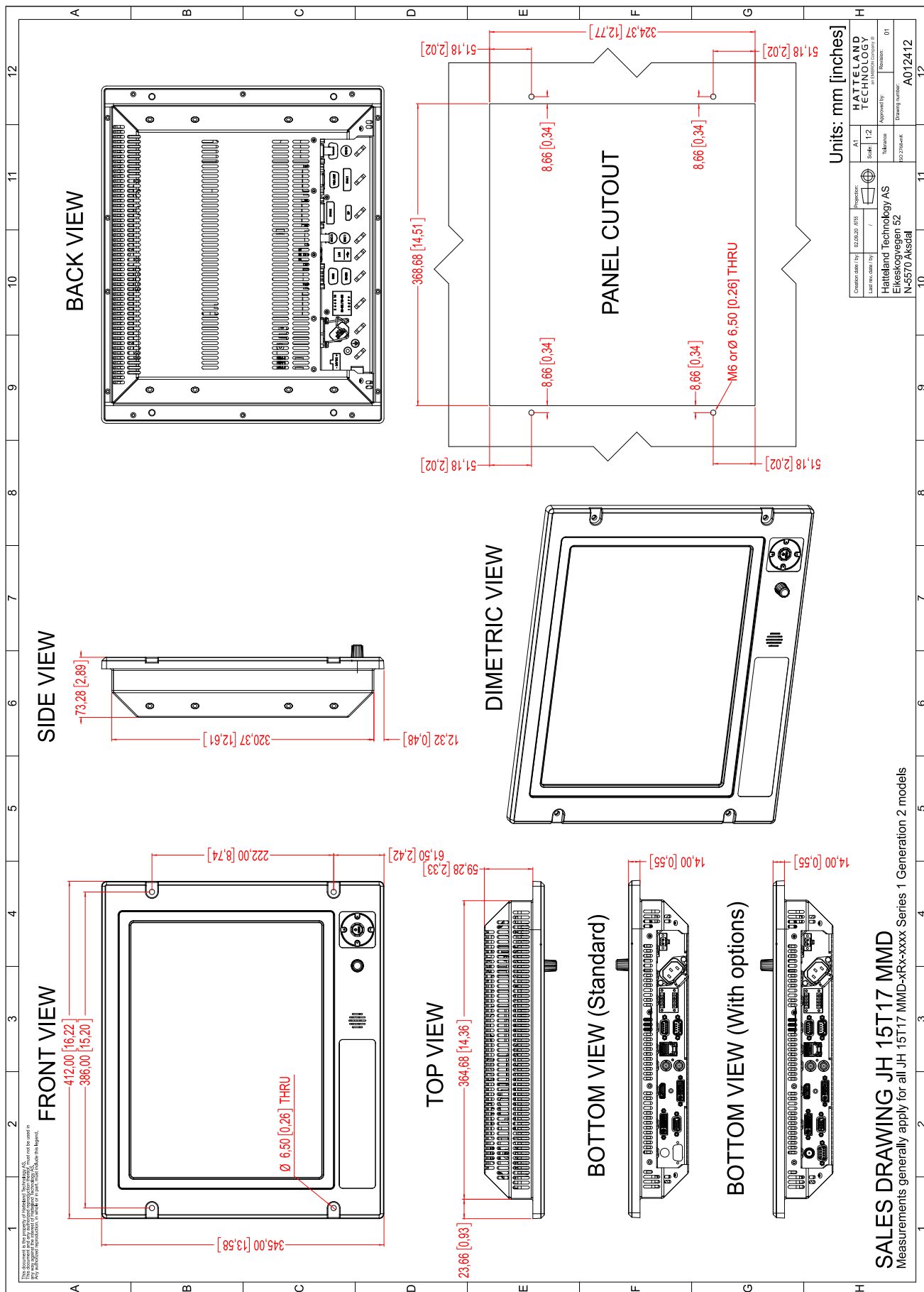

This document is the property of Hatteland Technology AS. This document and any authorized reproduction thereof, must not be used in any way against the interest of Hatteland Technology AS. Any authorized reproduction, in whole or in part, must include this legend. Hatteland Technology AS Proprietary information. Not to be distributed to any third party without written permission.

# Technical Drawings - JH 15T17 MMD-xRx-xxxx

Dimensions might be shown with or without decimals and indicated as mm [inches]. Tolerance on drawings is +/- 1mm. For accurate measurements, check relevant DWG file.

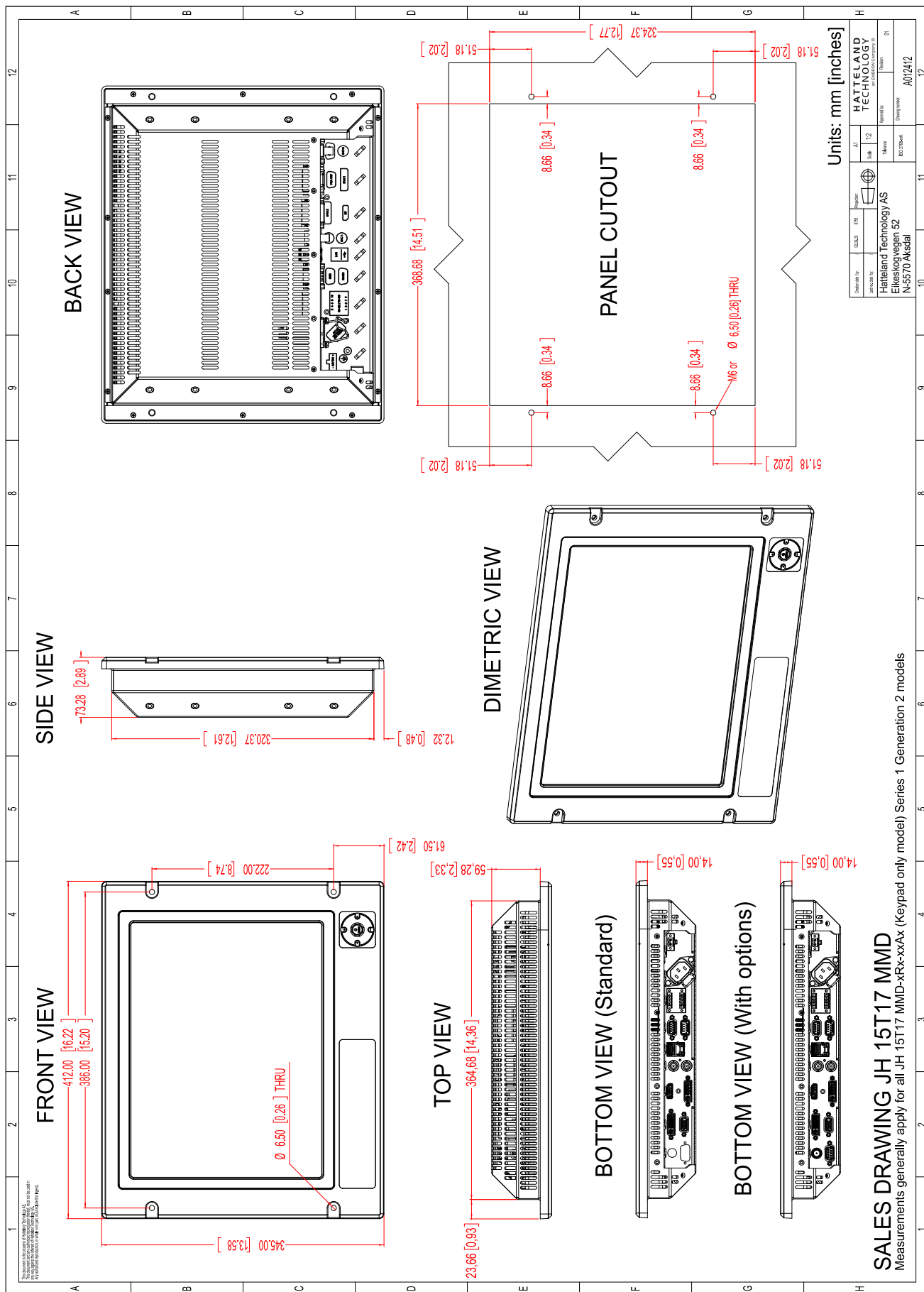

## SALES DRAWING JH 15T17 MMD

Measurements generally apply for all JH 15T17 MMD-xRx-xxAx (Keypad only model) Series 1 Generation 2 models

This document is the property of Hatteland Technology AS. This document and any authorized reproduction thereof, must not be used in any way against the interest of Hatteland Technology AS. Any authorized reproduction, in whole or in part, must include this legend. Hatteland Technology AS Proprietary information. Not to be distributed to any third party without written permission.





# Technical Drawings - JH 20T17 MMD-xRx-xxxx

Dimensions might be shown with or without decimals and indicated as mm [inches]. Tolerance on drawings is +/- 1mm. For accurate measurements, check relevant DWG file.

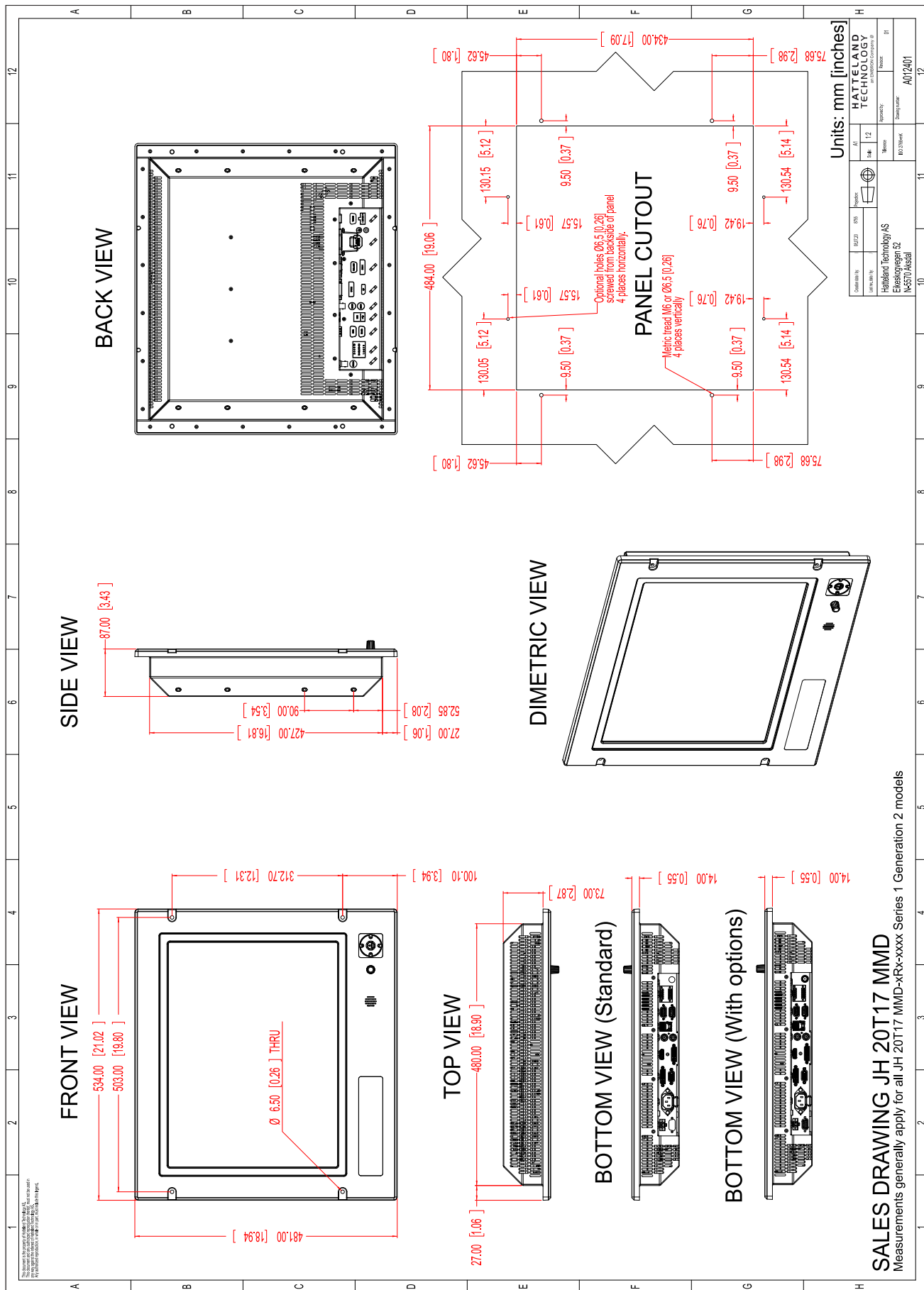



This page left intentionally blank



# **Technical Drawings - Accessories**

# Technical Drawings - JH 15TSV STD-A1

Dimensions might be shown with or without decimals and indicated as mm [inches]. Tolerance on drawings is +/- 1mm. For accurate measurements, check relevant DWG file.

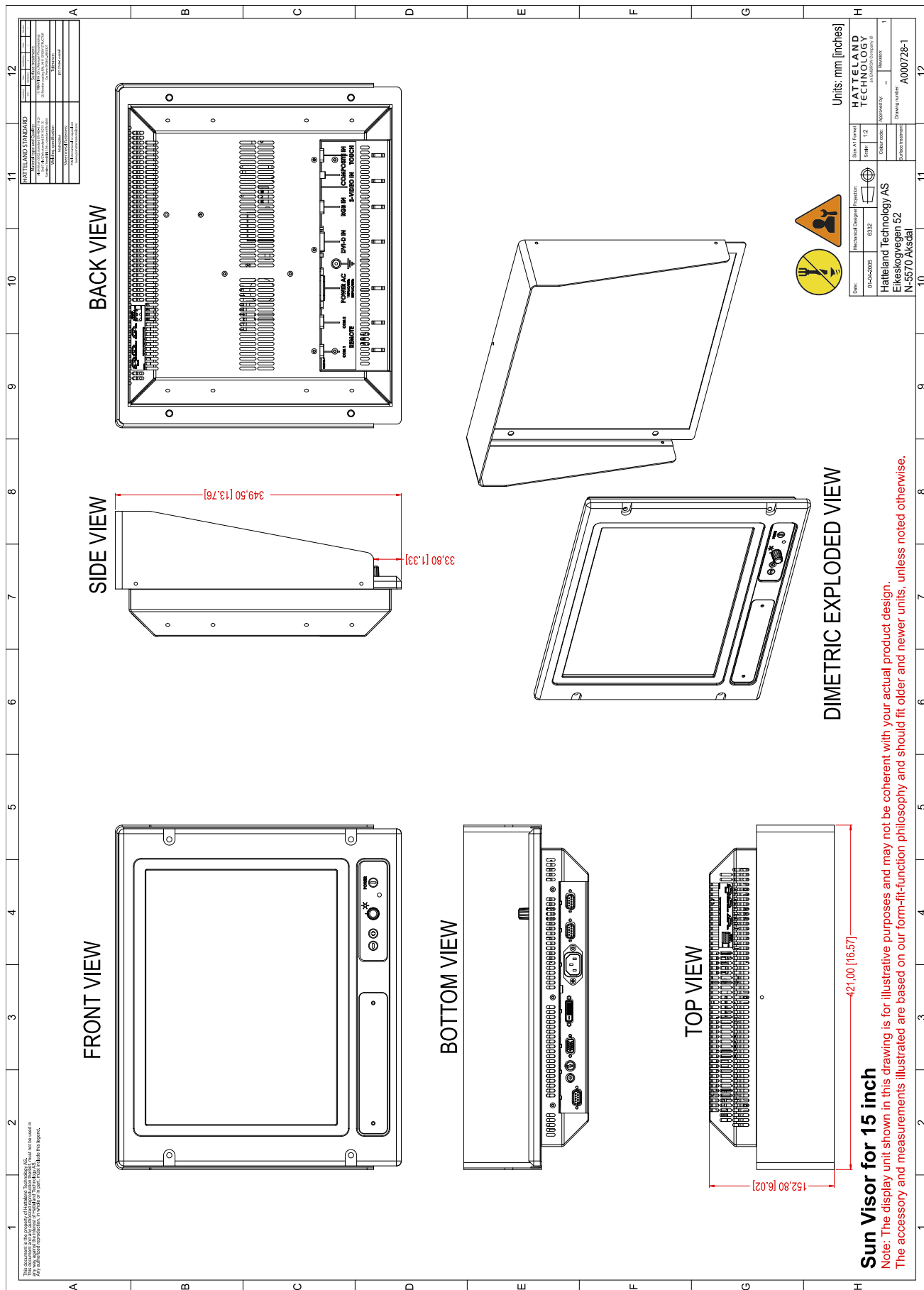

This document is the property of Hatteland Technology AS. This document and any authorized reproduction thereof, must not be used in any way against the interest of Hatteland Technology AS. Any authorized reproduction, in whole or in part, must include this legend. Hatteland Technology AS Proprietary information. Not to be distributed to any third party without written permission.

# Technical Drawings - JH 19TSV STD-B1

Dimensions might be shown with or without decimals and indicated as mm [inches]. Tolerance on drawings is +/- 1mm. For accurate measurements, check relevant DWG file.

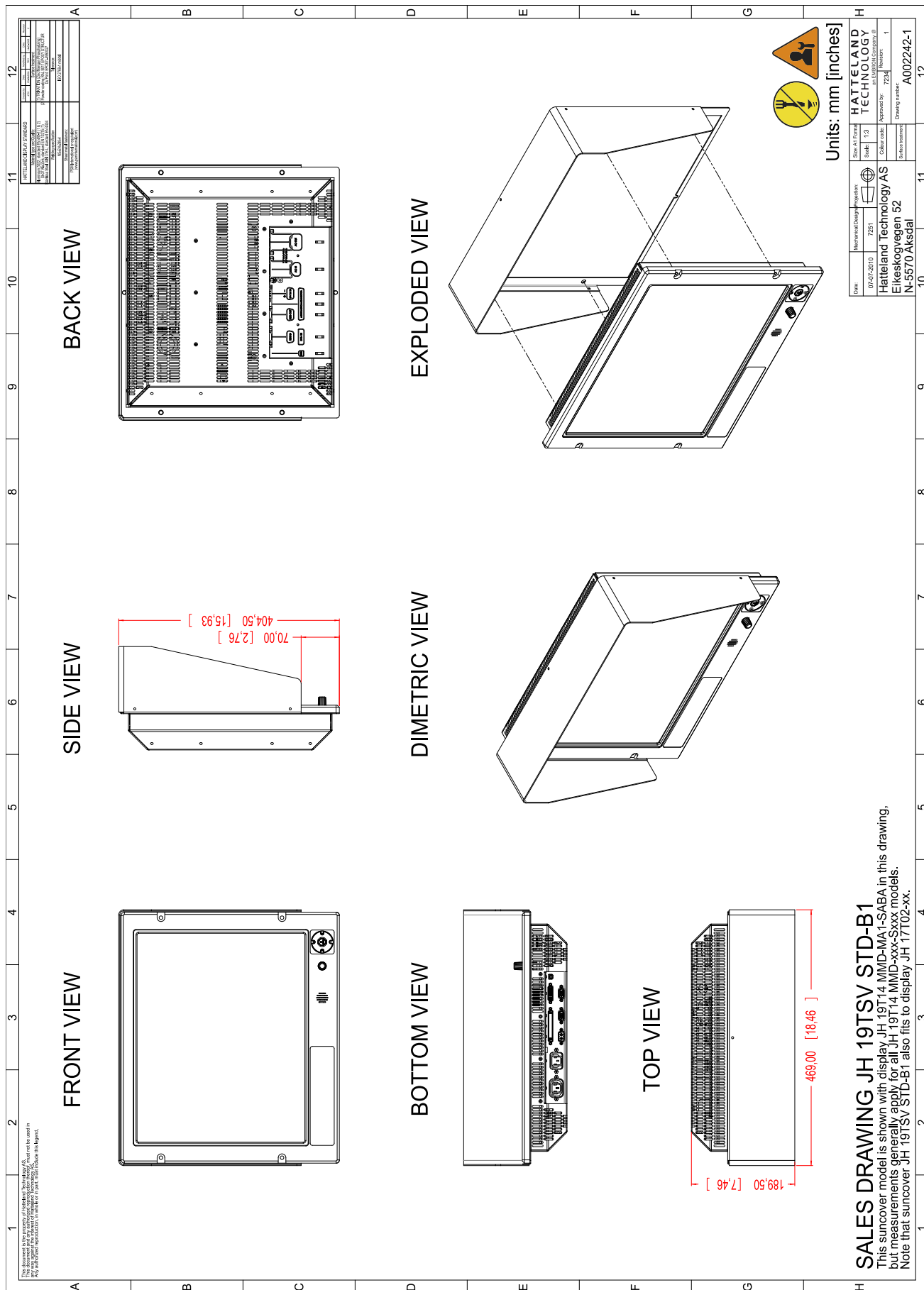

This document is the property of Hatteland Technology AS. This document and any authorized reproduction thereof, must not be used in any way against the interest of Hatteland Technology AS. Any authorized reproduction, in whole or in part, must include this legend. Hatteland Technology AS Proprietary information. Not to be distributed to any third party without written permission.

# Technical Drawings - JH 19TSV STD-A1

Dimensions might be shown with or without decimals and indicated as mm [inches]. Tolerance on drawings is +/- 1mm. For accurate measurements, check relevant DWG file.

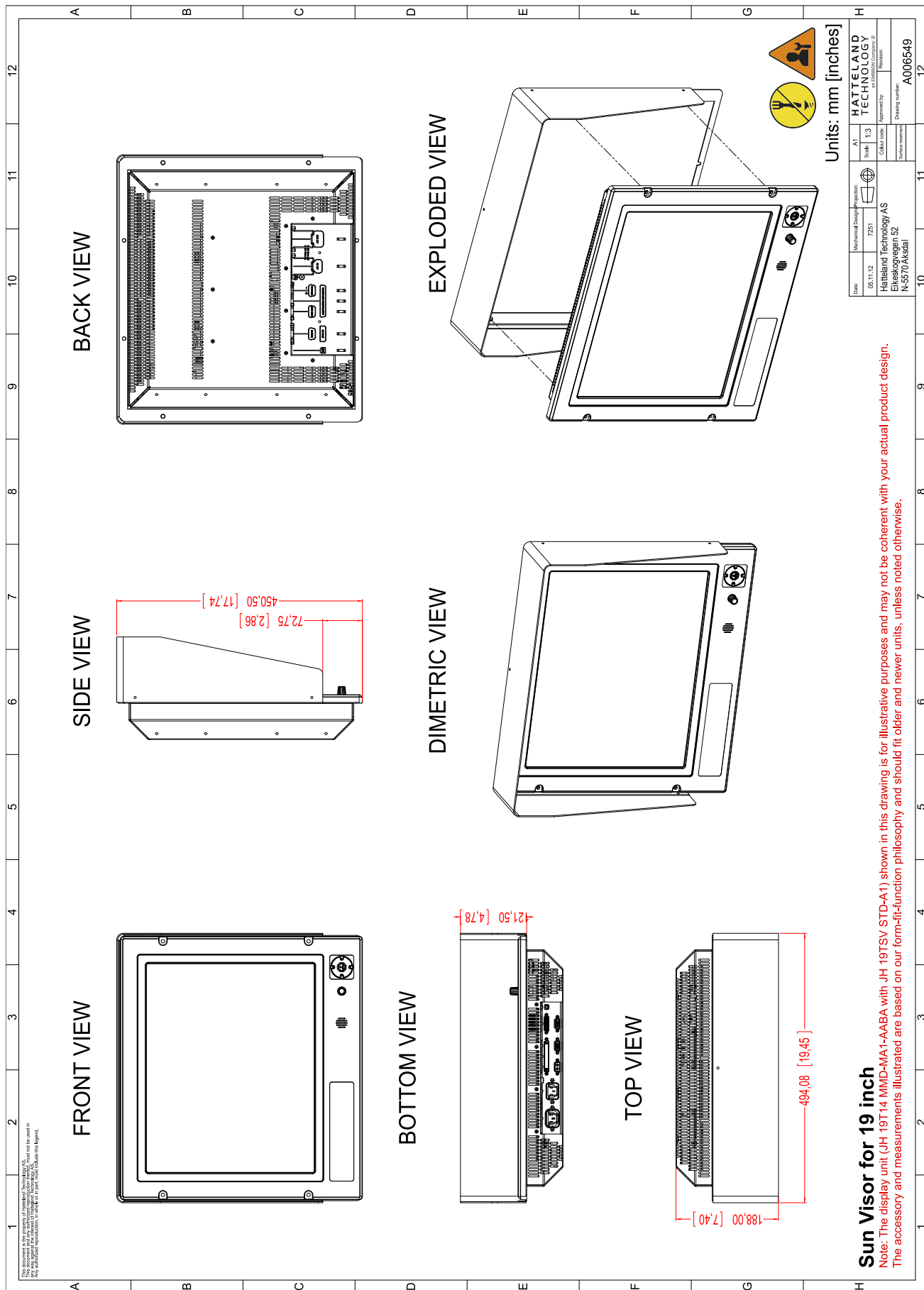

This document is the property of Hatteland Technology AS. This document and any authorized reproduction thereof, must not be used in any way against the interest of Hatteland Technology AS. Any authorized reproduction, in whole or in part, must include this legend. Hatteland Technology AS Proprietary information. Not to be distributed to any third party without written permission.

# Technical Drawings - JH 20TSV STD-B1

Dimensions might be shown with or without decimals and indicated as mm [inches]. Tolerance on drawings is +/- 1mm. For accurate measurements, check relevant DWG file.

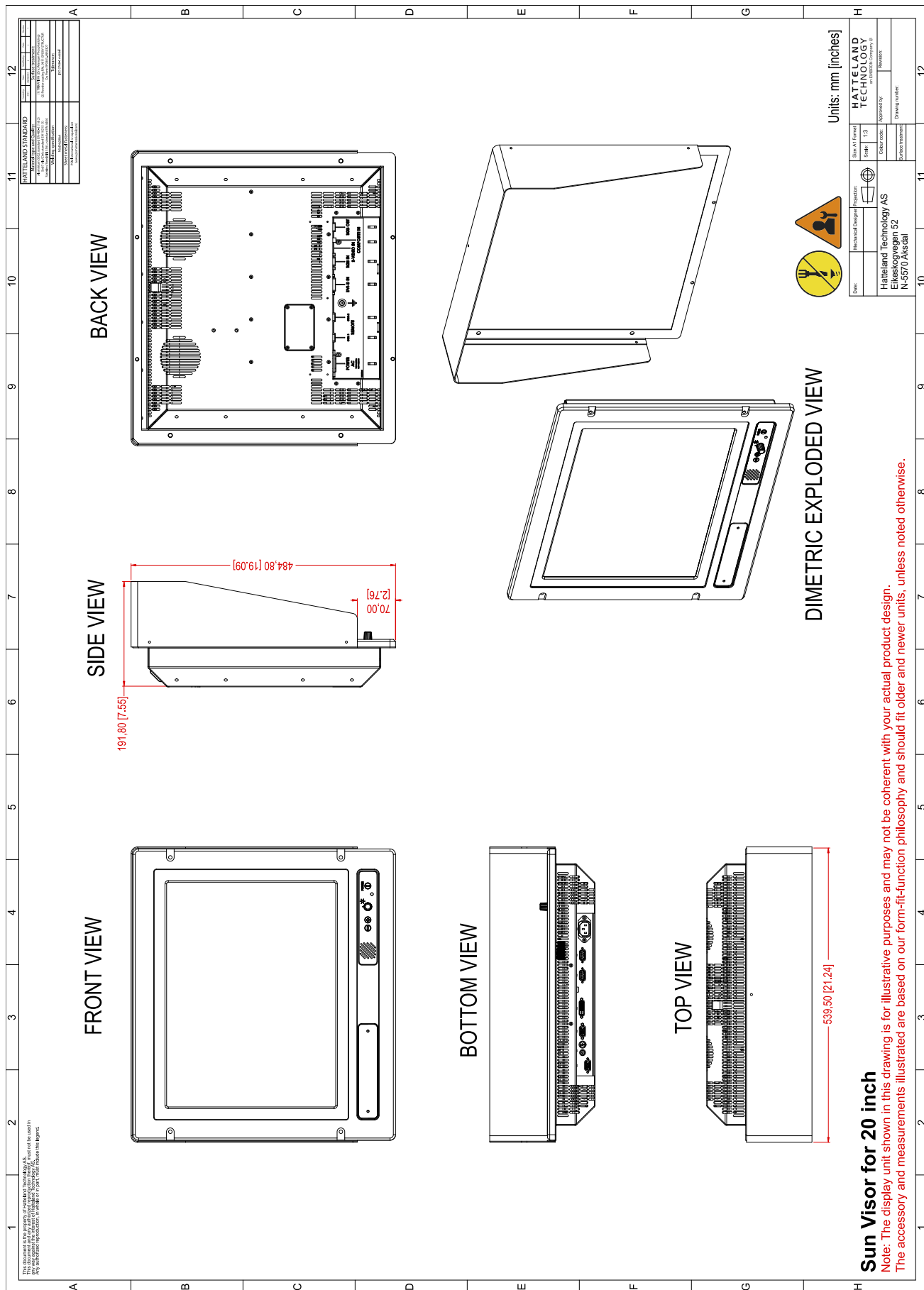

This document is the property of Hatteland Technology AS. This document and any authorized reproduction thereof, must not be used in any way against the interest of Hatteland Technology AS. Any authorized reproduction, in whole or in part, must include this legend. Hatteland Technology AS Proprietary information. Not to be distributed to any third party without written permission.

# Technical Drawings - JH 23TSV STD-A1

Dimensions might be shown with or without decimals and indicated as mm [inches]. Tolerance on drawings is +/- 1mm. For accurate measurements, check relevant DWG file.

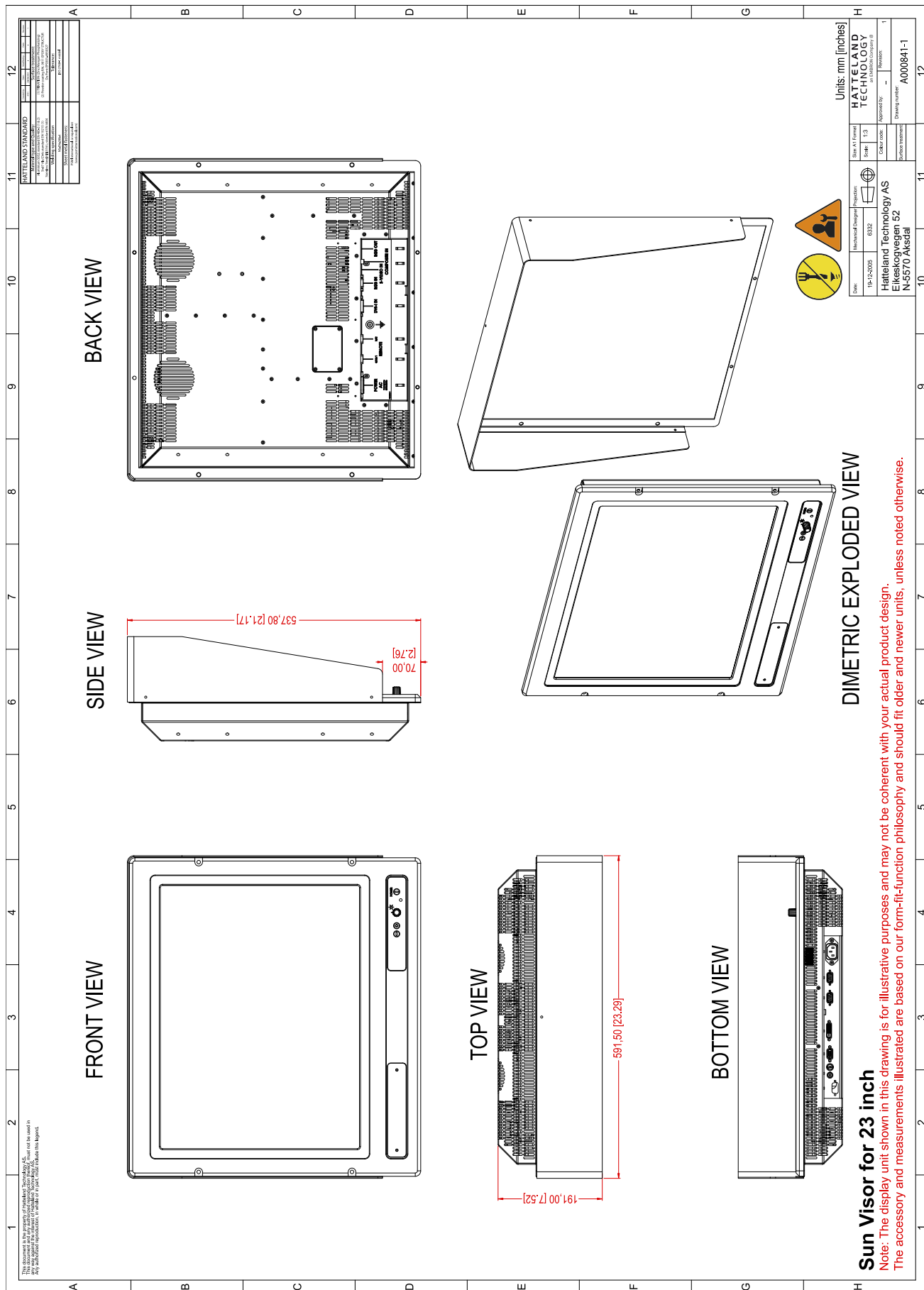

This document is the property of Hatteland Technology AS. This document and any authorized reproduction thereof, must not be used in any way against the interest of Hatteland Technology AS. Any authorized reproduction, in whole or in part, must include this legend. Hatteland Technology AS Proprietary information. Not to be distributed to any third party without written permission.

# Technical Drawings - JH 15TRO STD-A1

Dimensions might be shown with or without decimals and indicated as mm [inches]. Tolerance on drawings is +/- .1mm. For accurate measurements, check relevant DWG file.

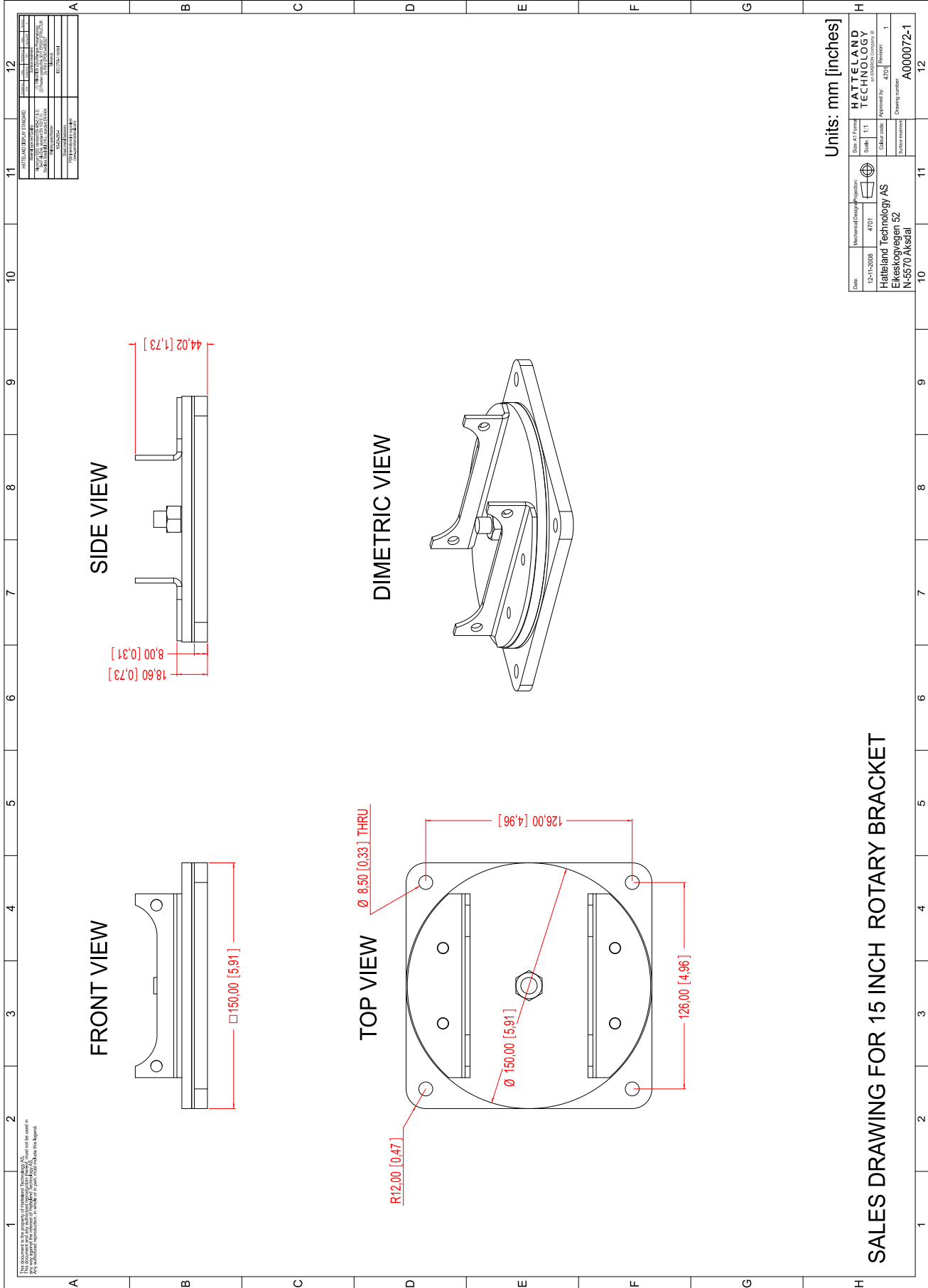

## SALES DRAWING FOR 15 INCH ROTARY BRACKET

This document is the property of Hatteland Technology AS. This document and any authorized reproduction thereof, must not be used in any way against the interest of Hatteland Technology AS. Any authorized reproduction, in whole or in part, must include this legend. Hatteland Technology AS Proprietary information. Not to be distributed to any third party without written permission.

# Technical Drawings - JH MMDRO STD-A1

Dimensions might be shown with or without decimals and indicated as mm [inches]. Tolerance on drawings is +/- 1mm. For accurate measurements, check relevant DWG file.

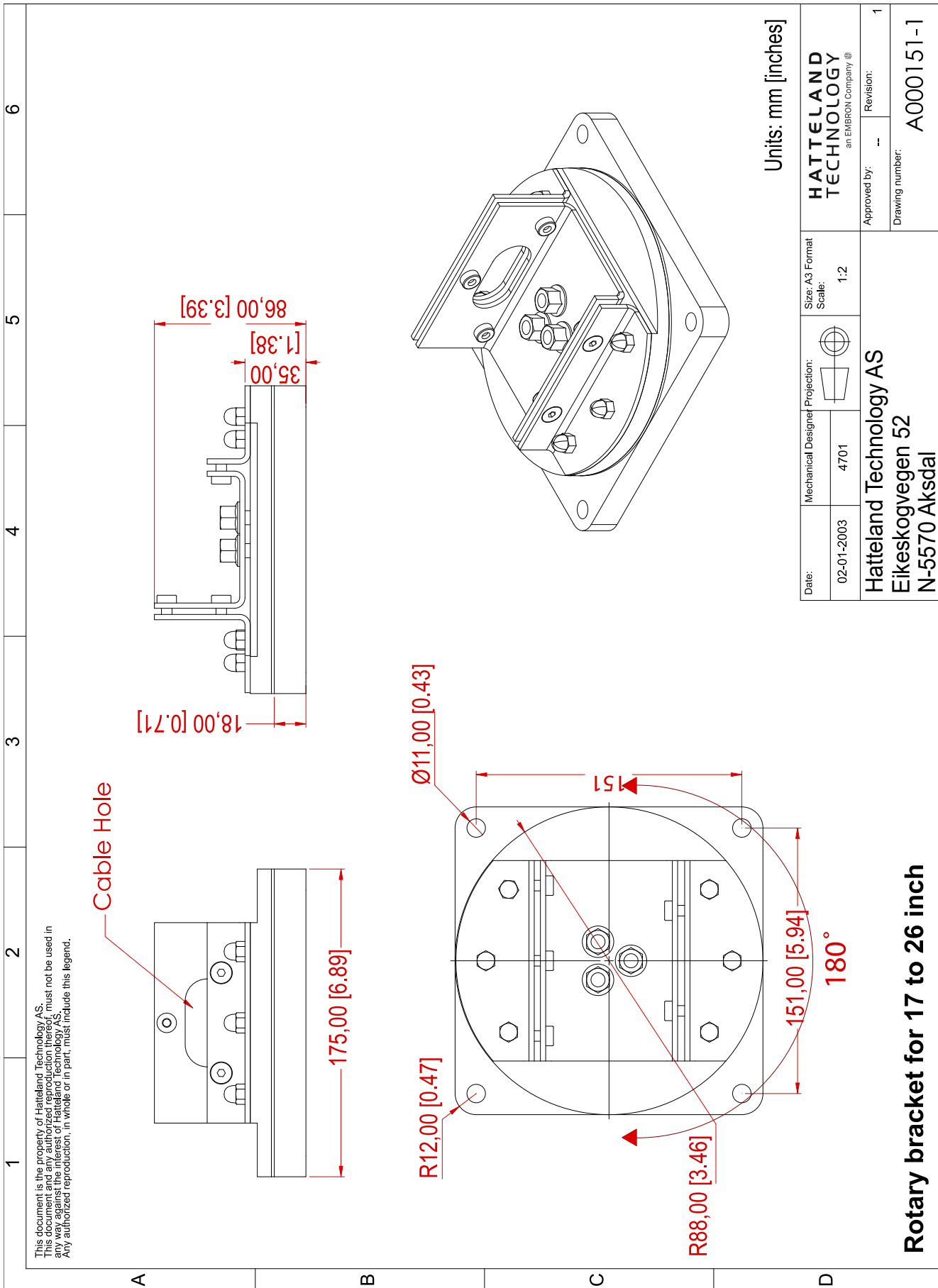

## Rotary bracket for 17 to 26 inch

This document is the property of Hatteland Technology AS. This document and any authorized reproduction thereof, must not be used in any way against the interest of Hatteland Technology AS. Any authorized reproduction, in whole or in part, must include this legend. Hatteland Technology AS Proprietary information. Not to be distributed to any third party without written permission.

# Technical Drawings - JH 15TBR STD-B1

Dimensions might be shown with or without decimals and indicated as mm [inches]. Tolerance on drawings is +/- 1mm. For accurate measurements, check relevant DWG file.

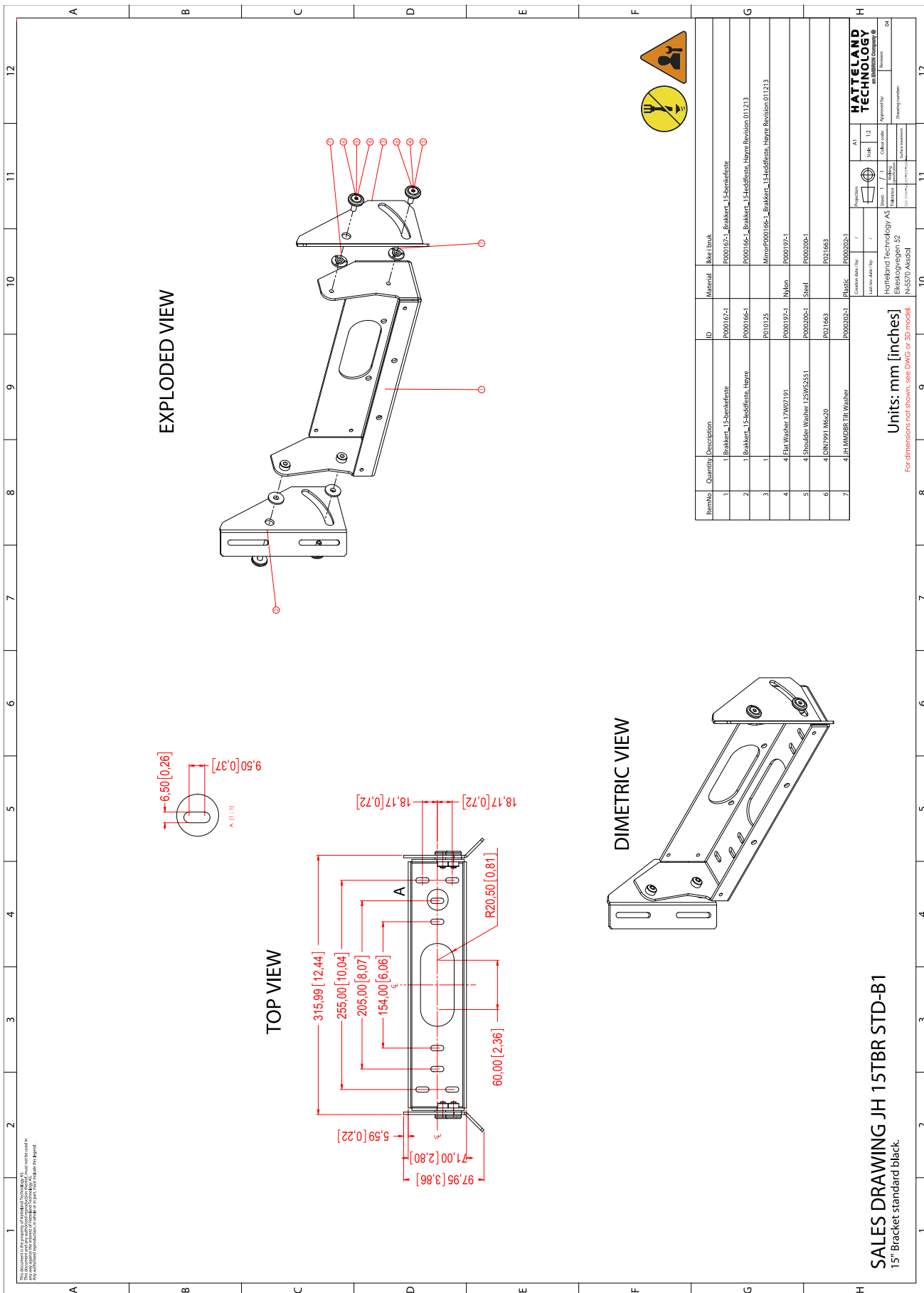

This document is the property of Hatteland Technology AS. This document and any authorized reproduction thereof, must not be used in any way against the interest of Hatteland Technology AS. Any authorized reproduction, in whole or in part, must include this legend. Hatteland Technology AS Proprietary information. Not to be distributed to any third party without written permission.

# Technical Drawings - JH MMDBR STD-A1

Dimensions might be shown with or without decimals and indicated as mm [inches]. Tolerance on drawings is +/- 1mm. For accurate measurements, check relevant DWG file.

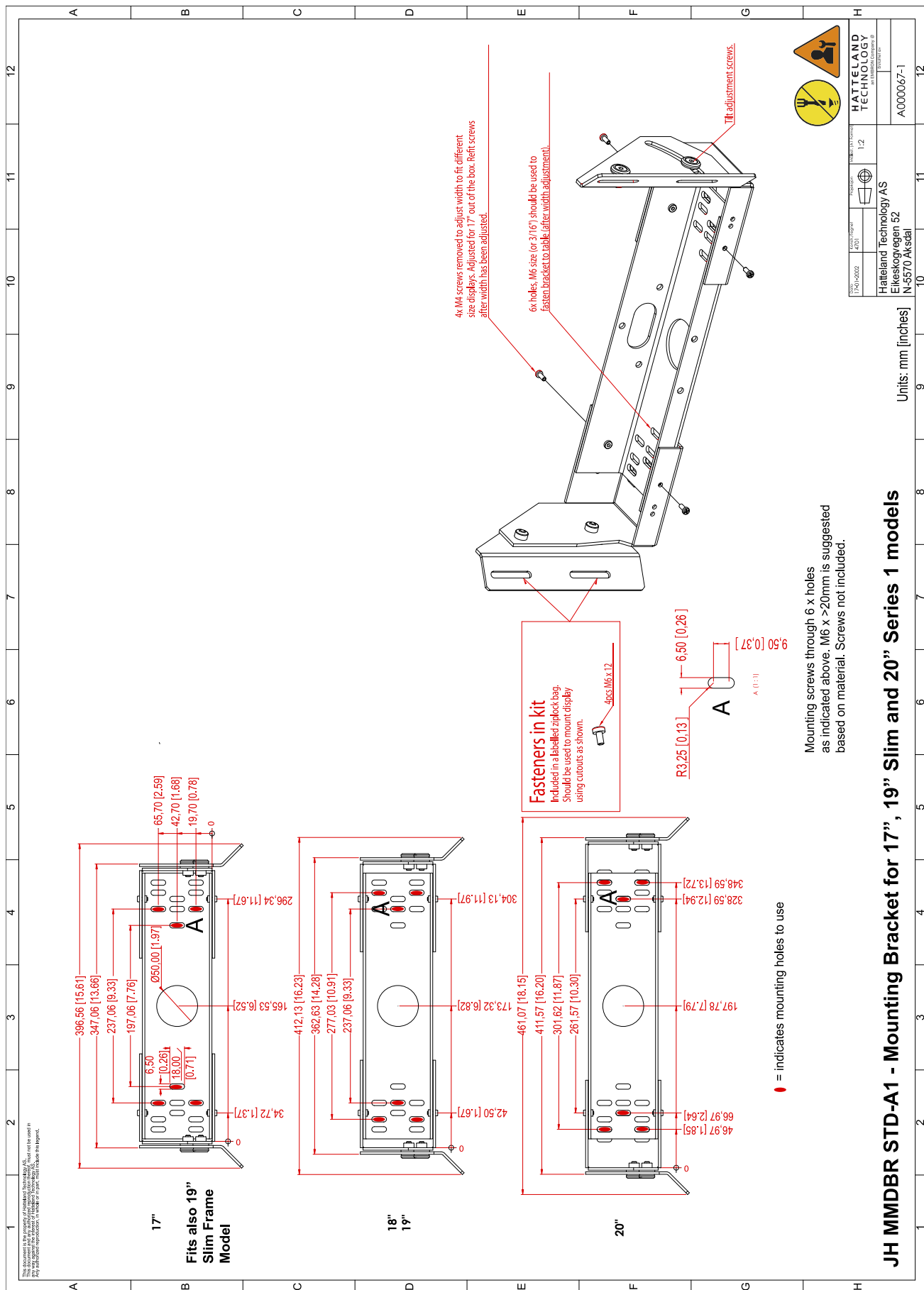

# Technical Drawings - JH 19TBR STD-B1

Dimensions might be shown with or without decimals and indicated as mm [inches]. Tolerance on drawings is +/- 1mm. For accurate measurements, check relevant DWG file.

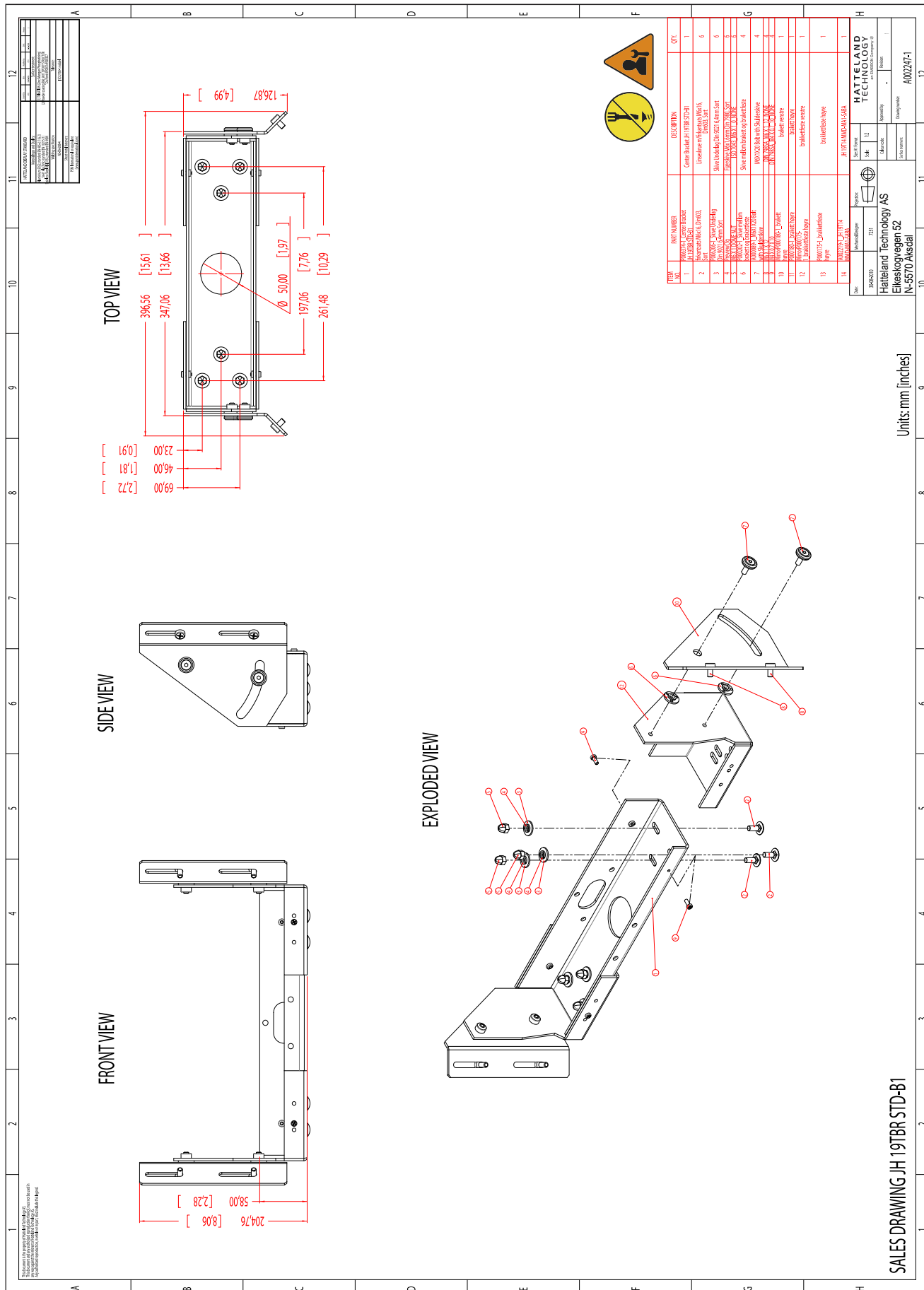

This document is the property of Hatteland Technology AS. This document and any authorized reproduction thereof, must not be used in any way against the interest of Hatteland Technology AS. Any authorized reproduction, in whole or in part, must include this legend. Hatteland Technology AS Proprietary information. Not to be distributed to any third party without written permission.

# Technical Drawings - JH 19BRD STD-A1

Dimensions might be shown with or without decimals and indicated as mm [inches]. Tolerance on drawings is +/- 1mm. For accurate measurements, check relevant DWG file.

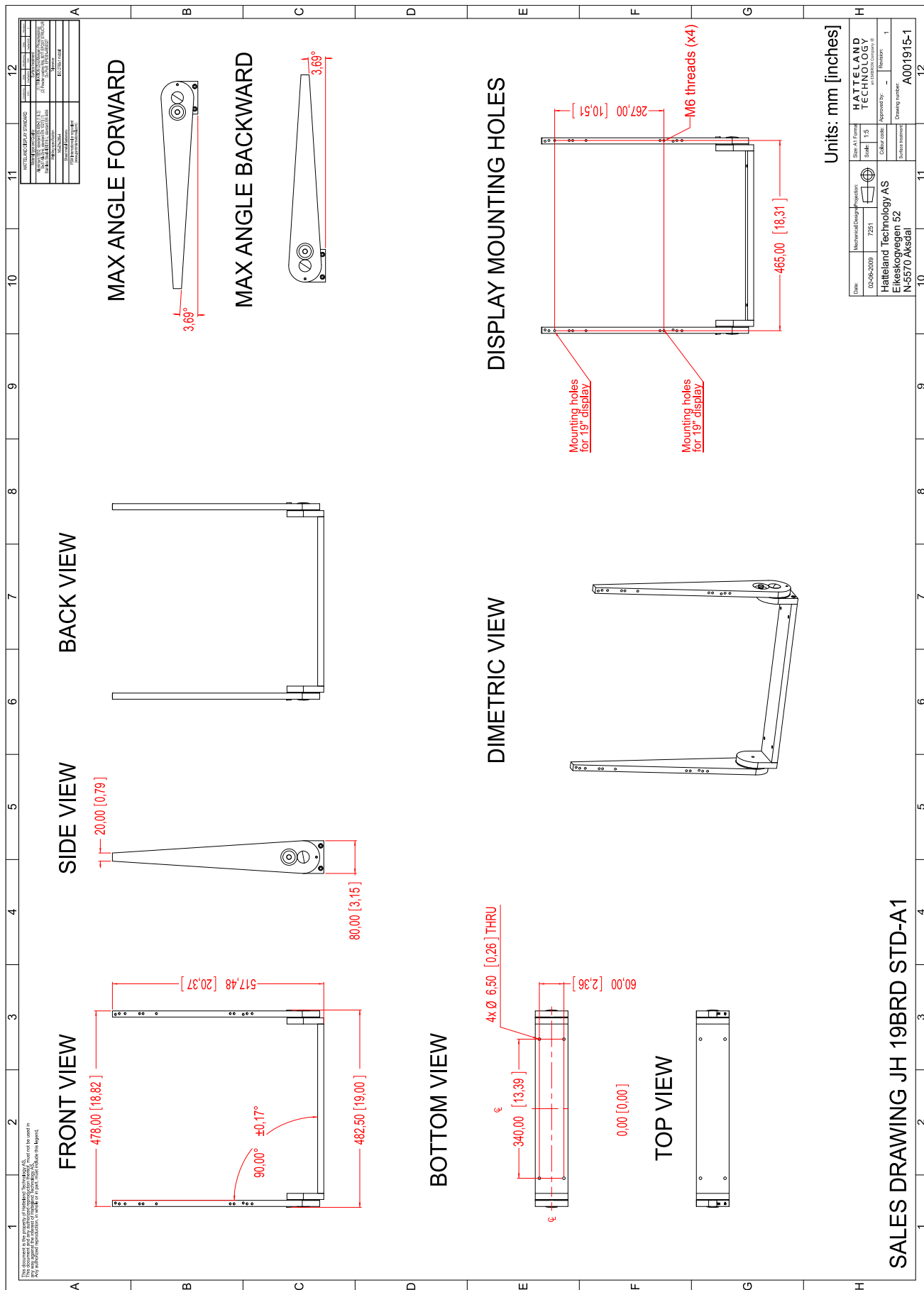

This document is the property of Hatteland Technology AS. This document and any authorized reproduction thereof, must not be used in any way against the interest of Hatteland Technology AS. Any authorized reproduction, in whole or in part, must include this legend. Hatteland Technology AS Proprietary information. Not to be distributed to any third party without written permission.

# Technical Drawings - JH 23TBR T01-A1

Dimensions might be shown with or without decimals and indicated as mm [inches]. Tolerance on drawings is +/- 1mm. For accurate measurements, check relevant DWG file.

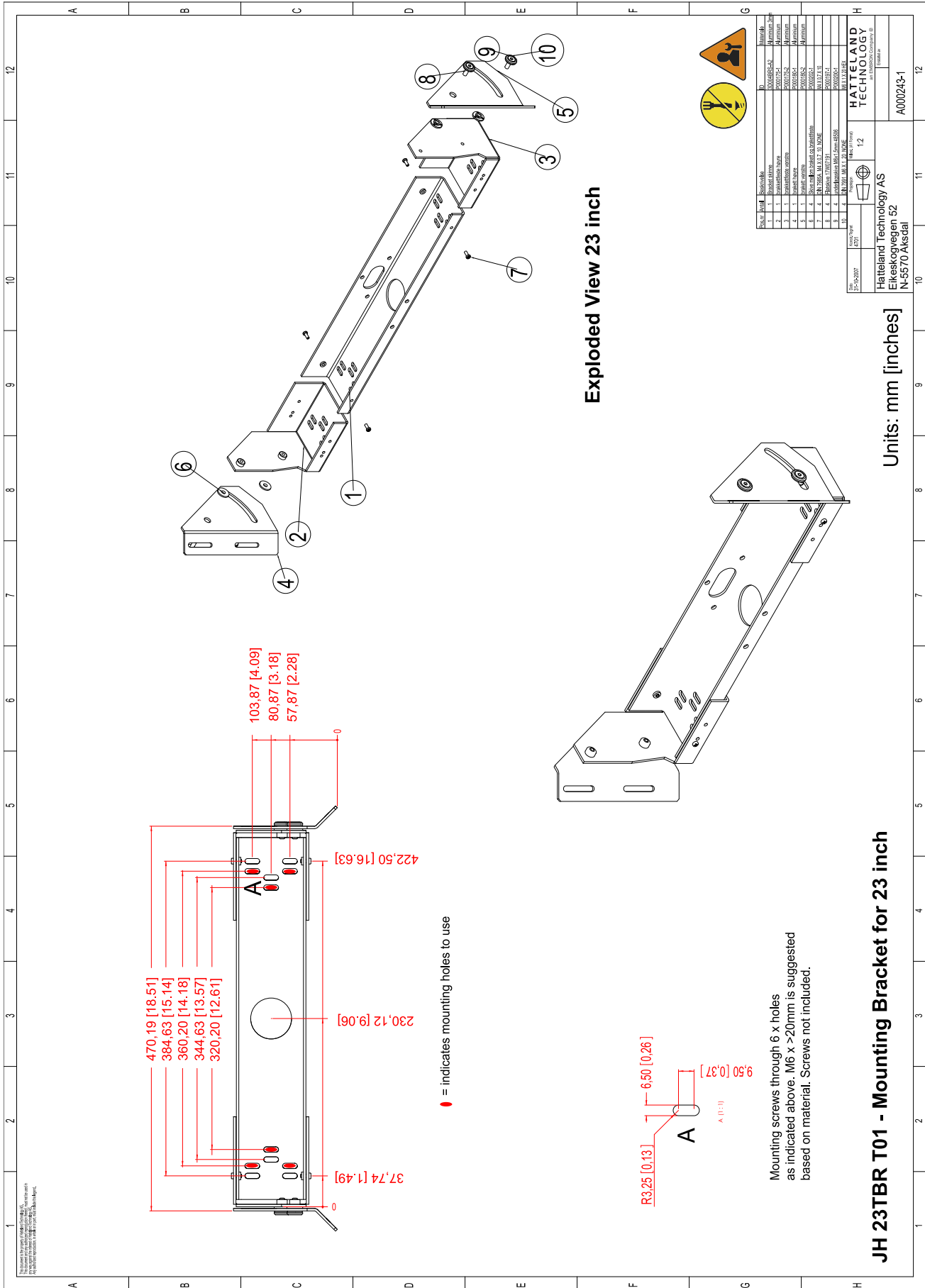

# Technical Drawings - JH 23BRD STD-A1

Dimensions might be shown with or without decimals and indicated as mm [inches]. Tolerance on drawings is +/- .1mm. For accurate measurements, check relevant DWG file.

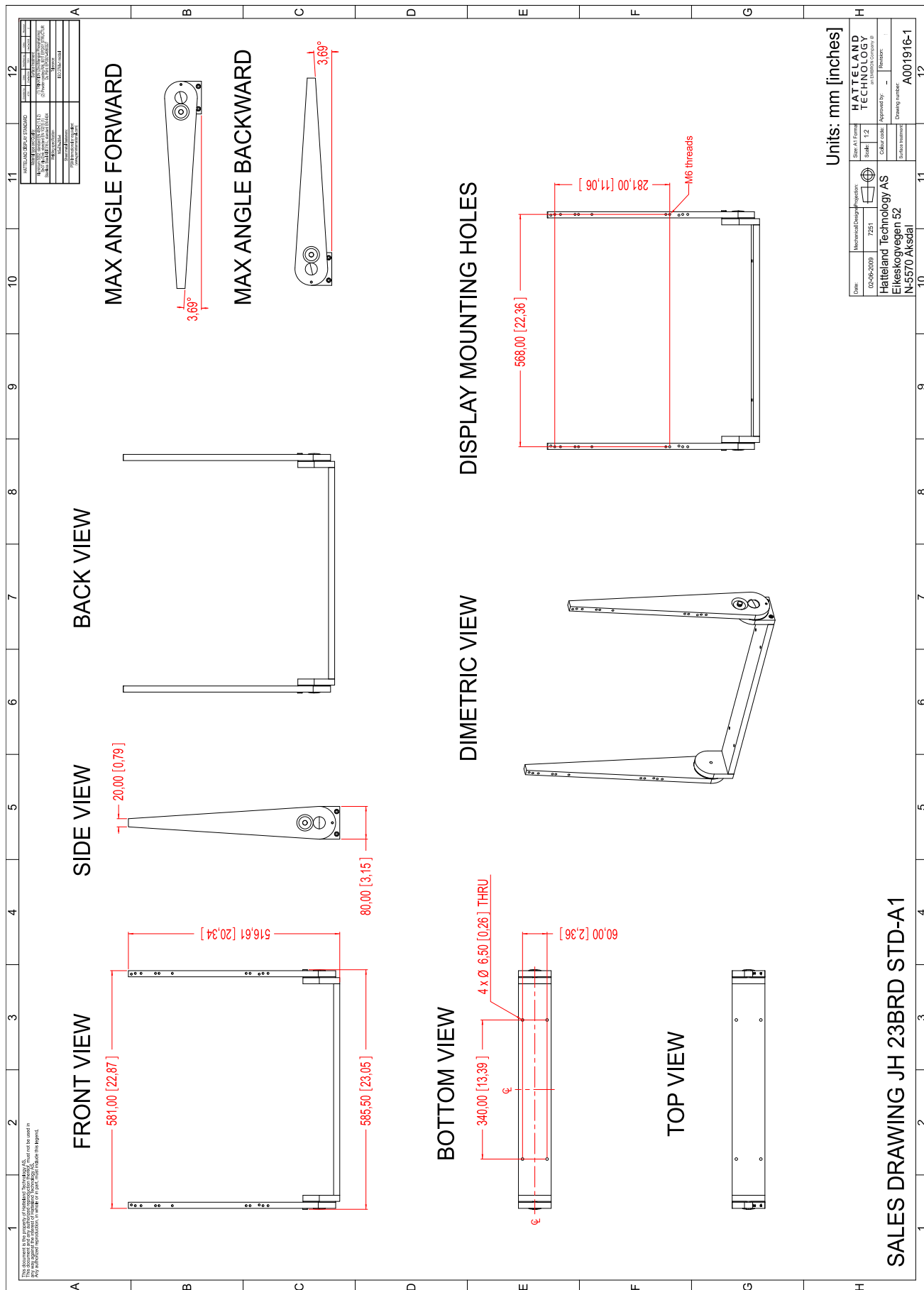

This document is the property of Hatteland Technology AS. This document and any authorized reproduction thereof, must not be used in any way against the interest of Hatteland Technology AS. Any authorized reproduction, in whole or in part, must include this legend. Hatteland Technology AS Proprietary information. Not to be distributed to any third party without written permission.

# Technical Drawings - JH 15TAP STD-A1

Dimensions might be shown with or without decimals and indicated as mm [inches]. Tolerance on drawings is +/- 1mm. For accurate measurements, check relevant DWG file.

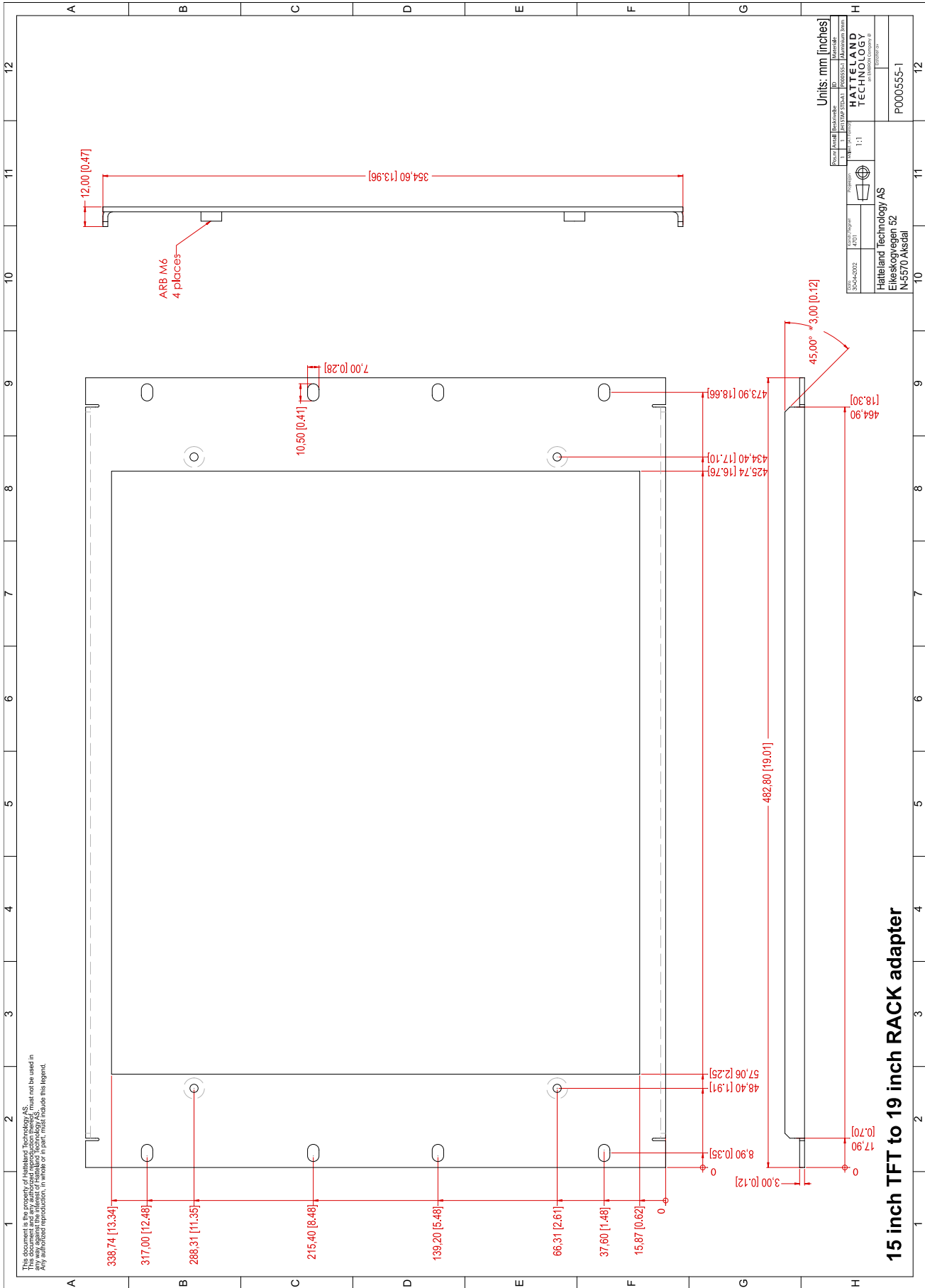

This document is the property of Hatteland Technology AS. This document and any authorized reproduction thereof, must not be used in any way against the interest of Hatteland Technology AS. Any authorized reproduction, in whole or in part, must include this legend. Hatteland Technology AS Proprietary information. Not to be distributed to any third party without written permission.

# Technical Drawings - JH 15TAP STD-B1

Dimensions might be shown with or without decimals and indicated as mm [inches]. Tolerance on drawings is +/- 1mm. For accurate measurements, check relevant DWG file.

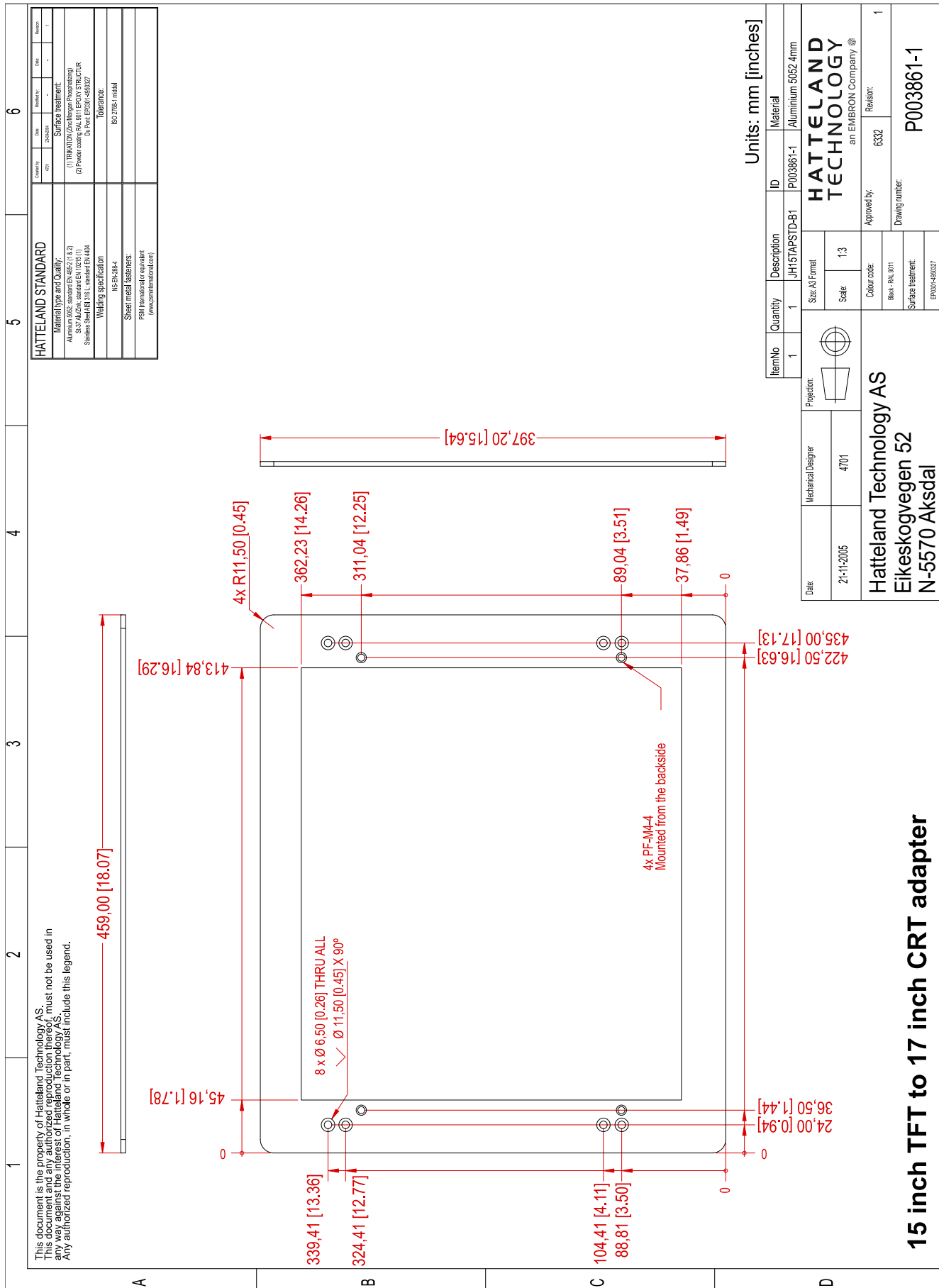

## 15 inch TFT to 17 inch CRT adapter

This document is the property of Hatteland Technology AS. This document and any authorized reproduction thereof, must not be used in any way against the interest of Hatteland Technology AS. Any authorized reproduction, in whole or in part, must include this legend. Hatteland Technology AS Proprietary information. Not to be distributed to any third party without written permission.

# Technical Drawings - JH 17TAP STD-A1

Dimensions might be shown with or without decimals and indicated as +/- 1mm. For accurate measurements, check relevant DWG file.

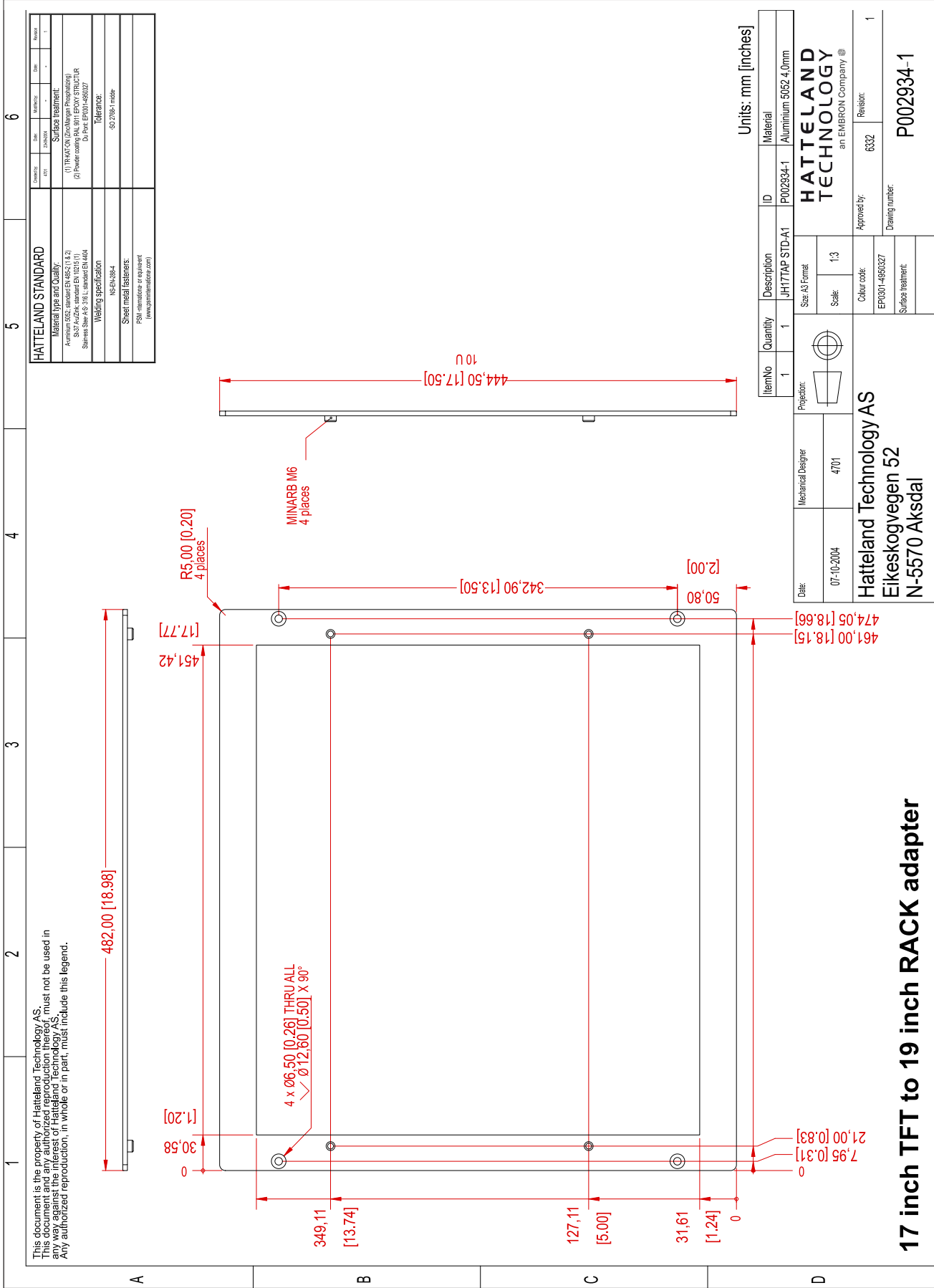

This document is the property of Hatteland Technology AS. This document and any authorized reproduction thereof, must not be used in any way against the interest of Hatteland Technology AS. Any authorized reproduction, in whole or in part, must include this legend. Hatteland Technology AS Proprietary information. Not to be distributed to any third party without written permission.

# Technical Drawings - JH 19TAP STD-A1

Dimensions might be shown with or without decimals and indicated as mm [inches]. Tolerance on drawings is +/- 1mm. For accurate measurements, check relevant DWG file.

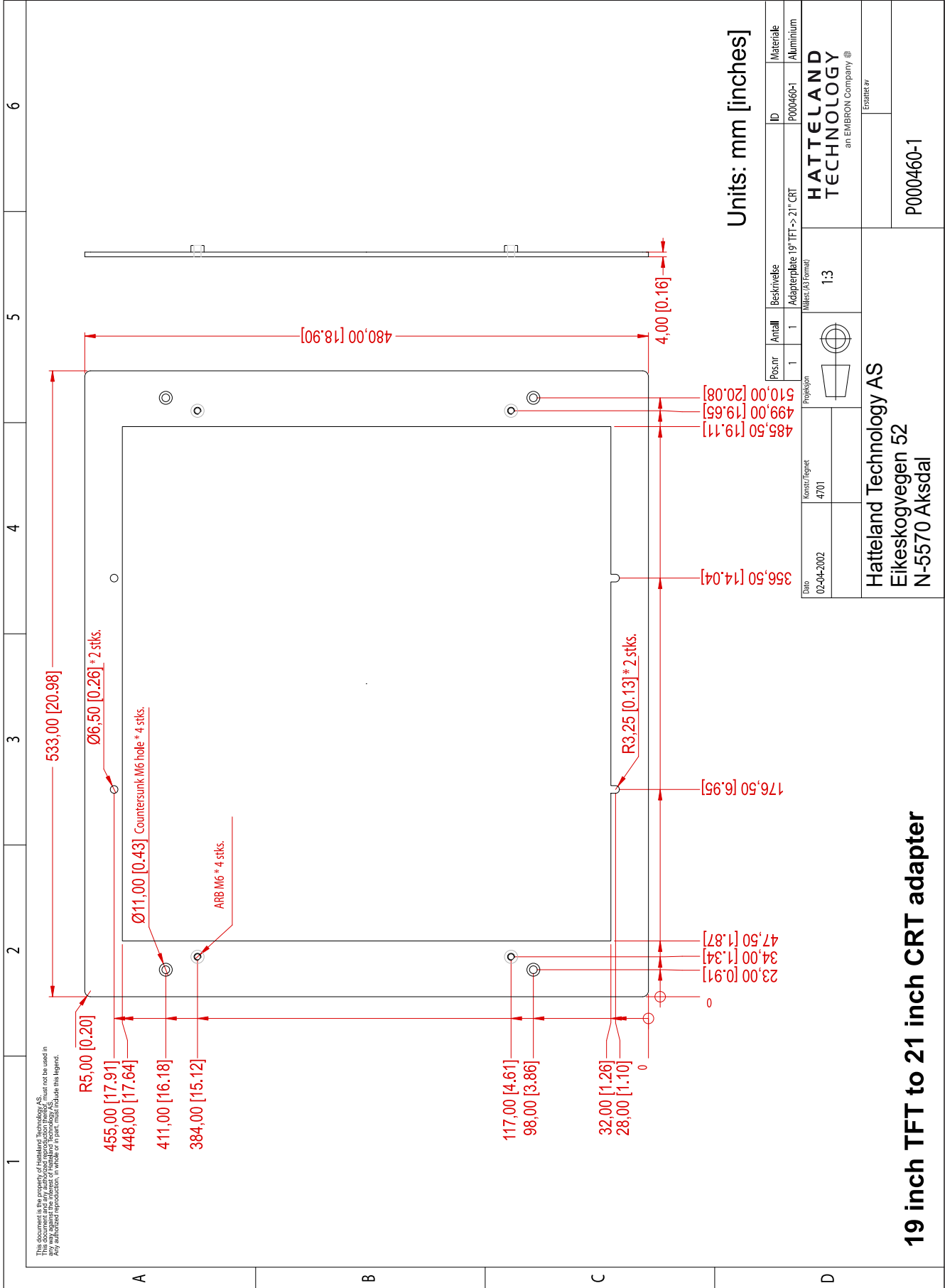

## 19 inch TFT to 21 inch CRT adapter

This document is the property of Hatteland Technology AS. This document and any authorized reproduction thereof, must not be used in any way against the interest of Hatteland Technology AS. Any authorized reproduction, in whole or in part, must include this legend. Hatteland Technology AS Proprietary information. Not to be distributed to any third party without written permission.

# Technical Drawings - JH 19TAP STD-A2

Dimensions might be shown with or without decimals and indicated as mm [inches]. Tolerance on drawings is +/- 1mm. For accurate measurements, check relevant DWG file.

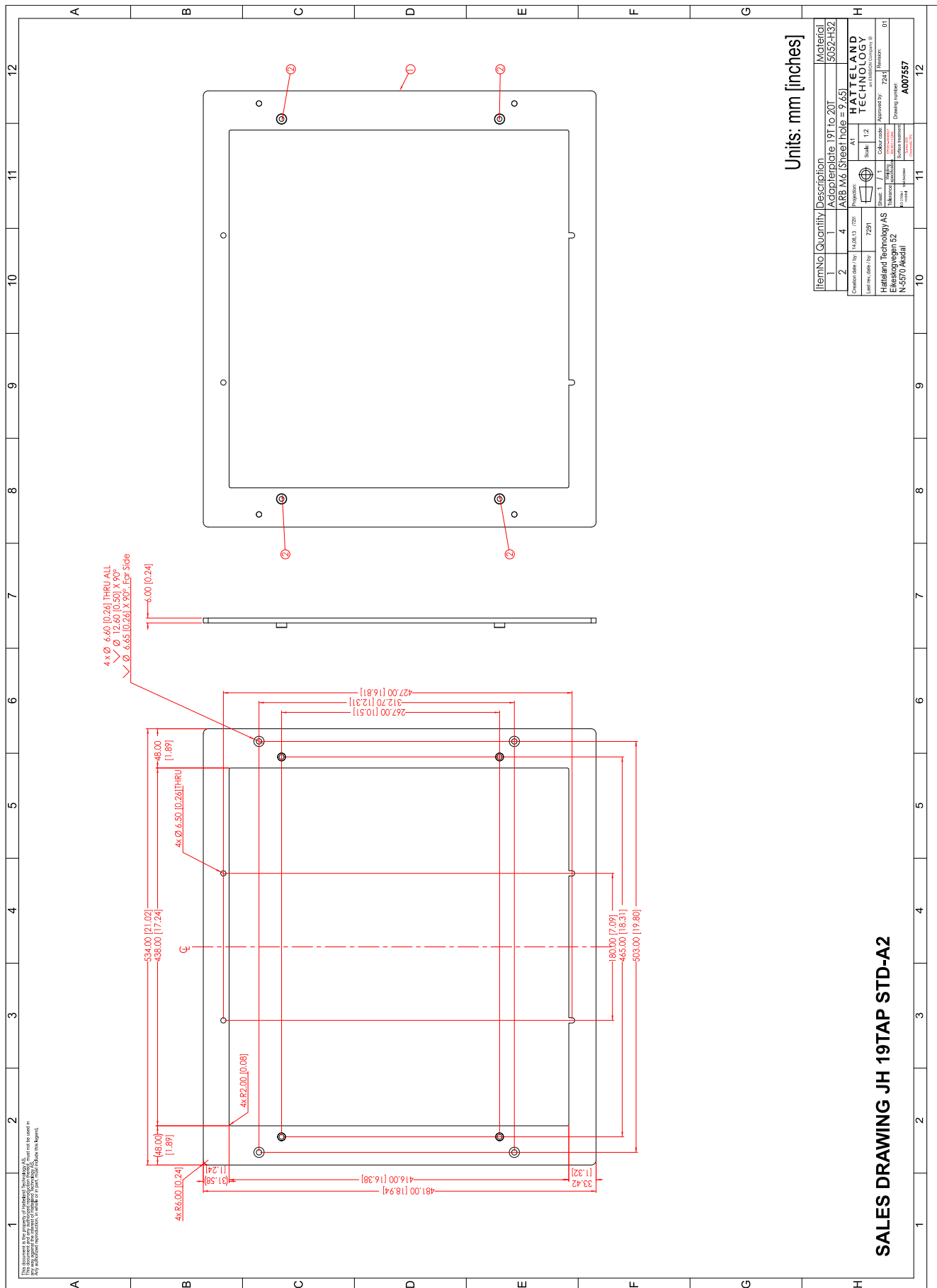

Units: mm [inches]

## SALES DRAWING JH 19TAP STD-A2

This document is the property of Hatteland Technology AS. This document and any authorized reproduction thereof, must not be used in any way against the interest of Hatteland Technology AS. Any authorized reproduction, in whole or in part, must include this legend. Hatteland Technology AS Proprietary information. Not to be distributed to any third party without written permission.

# Technical Drawings - JH 19TAP STD-B1

Dimensions might be shown with or without decimals and indicated as mm [inches]. Tolerance on drawings is +/- 1mm. For accurate measurements, check relevant DWG file.

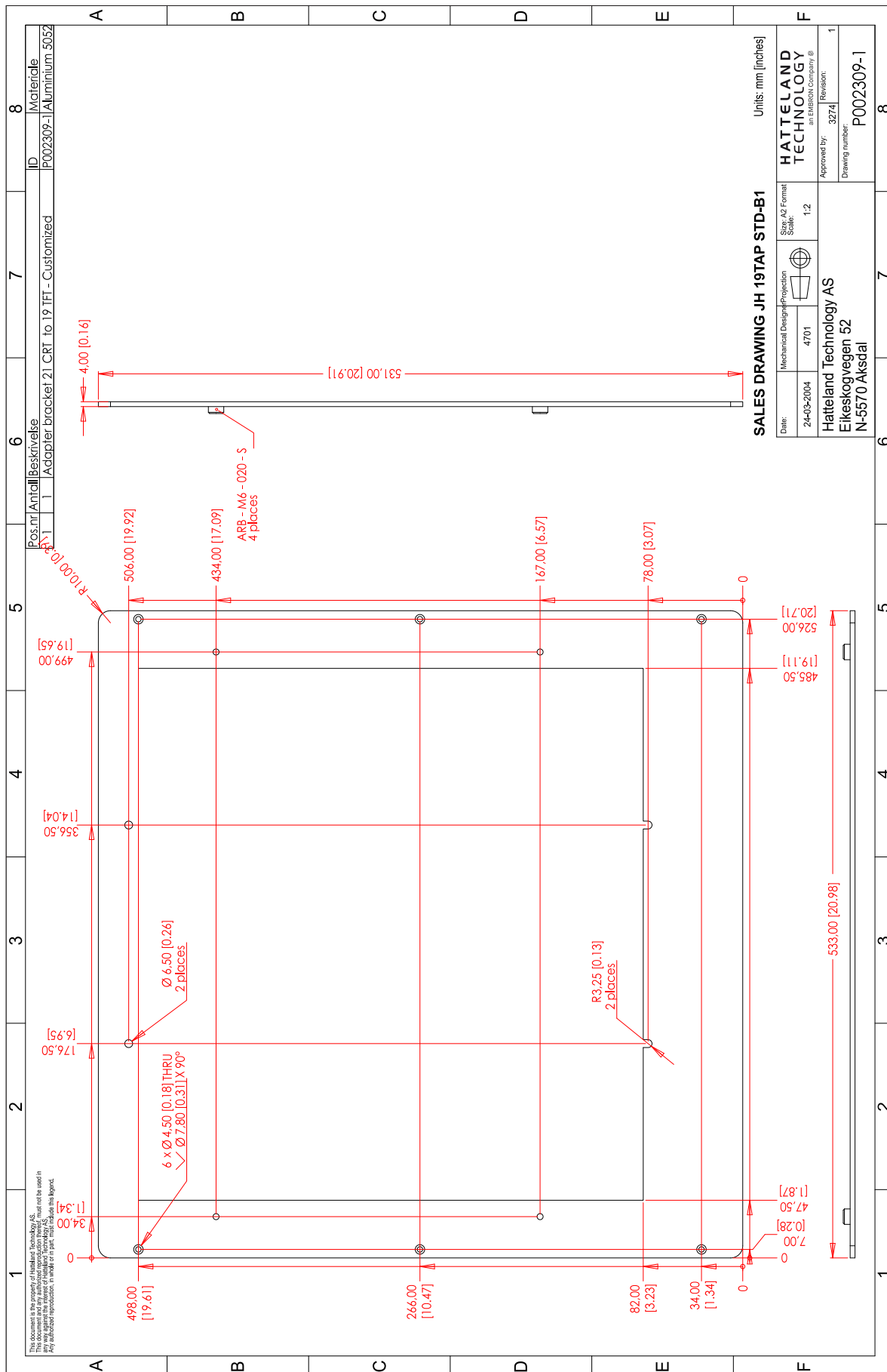

This document is the property of Hatteland Technology AS. This document and any authorized reproduction thereof, must not be used in any way against the interest of Hatteland Technology AS. Any authorized reproduction, in whole or in part, must include this legend. Hatteland Technology AS Proprietary information. Not to be distributed to any third party without written permission.

# Technical Drawings - JH 15VED STD-A1

Dimensions might be shown with or without decimals and indicated as mm [inches]. Tolerance on drawings is +/- 1mm. For accurate measurements, check relevant DWG file.

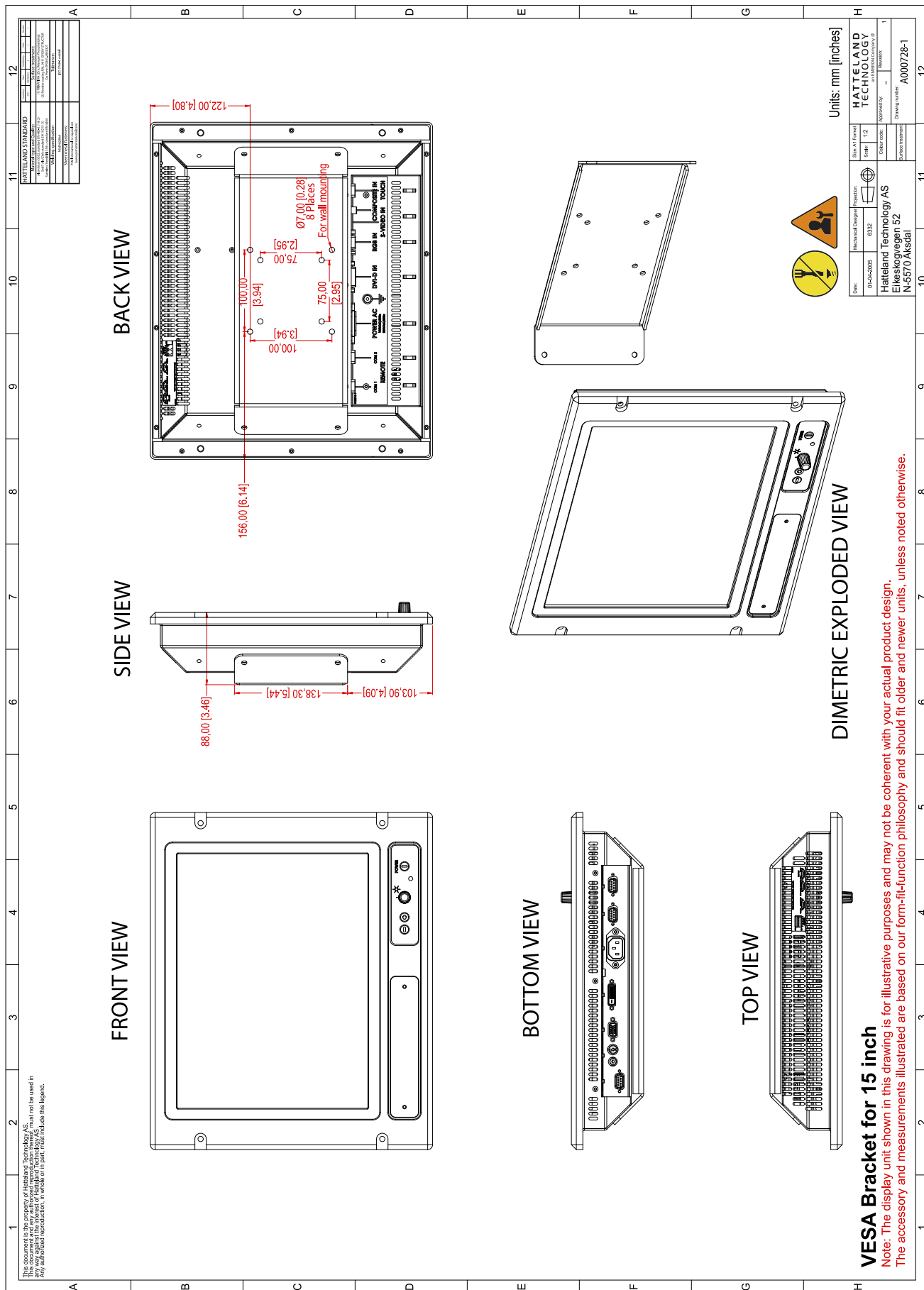

This document is the property of Hatteland Technology AS. This document and any authorized reproduction thereof, must not be used in any way against the interest of Hatteland Technology AS. Any authorized reproduction, in whole or in part, must include this legend. Hatteland Technology AS Proprietary information. Not to be distributed to any third party without written permission.

# Technical Drawings - JH 19VED STD-A1

Dimensions might be shown with or without decimals and indicated as mm [inches]. Tolerance on drawings is +/- 1mm. For accurate measurements, check relevant DWG file.

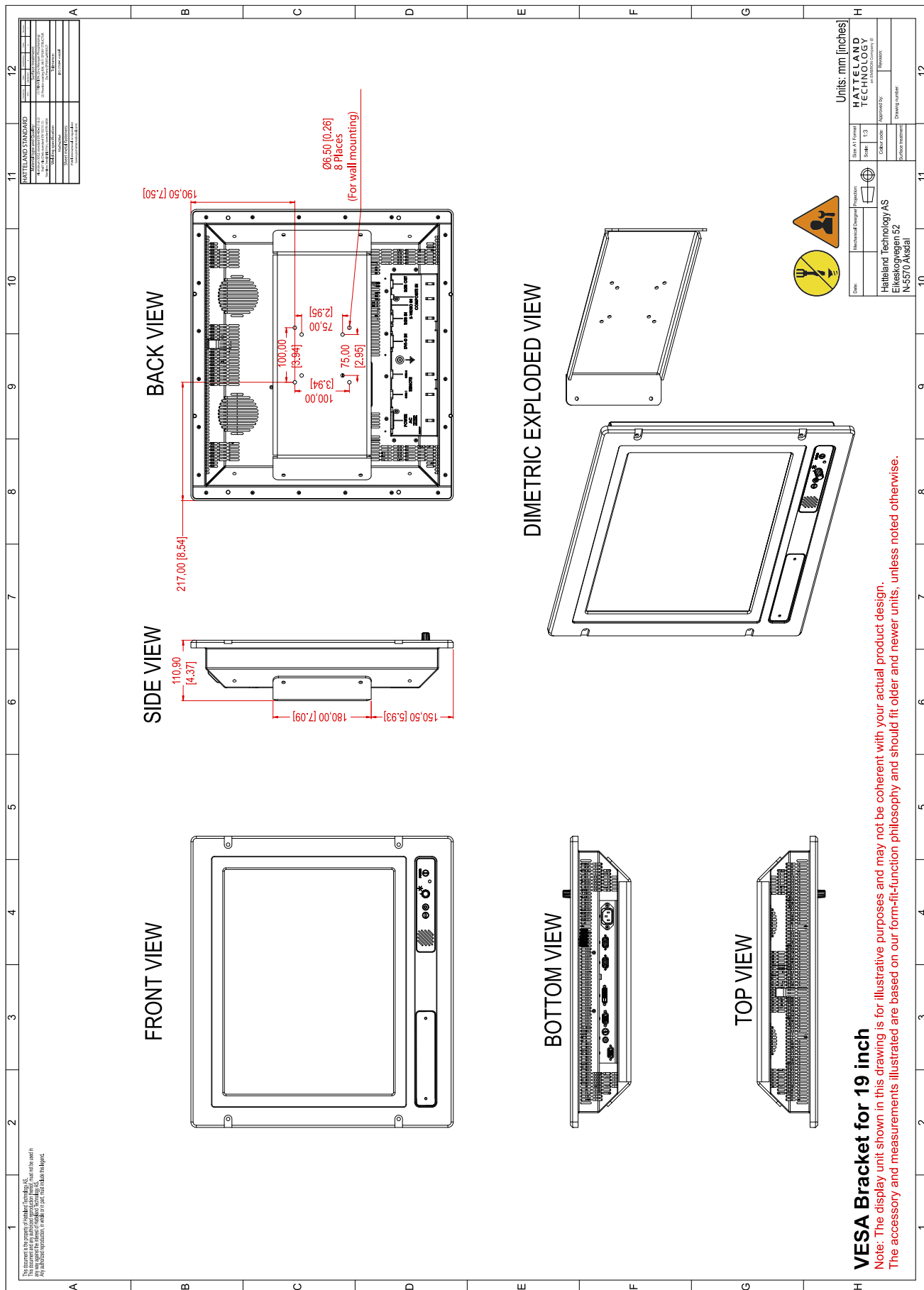

HATTELAND STANDARD	
1	Approved by: [Signature]
2	Checked by: [Signature]
3	Drawn by: [Signature]
4	Released by: [Signature]
5	Released by: [Signature]
6	Released by: [Signature]
7	Released by: [Signature]
8	Released by: [Signature]
9	Released by: [Signature]
10	Released by: [Signature]
11	Released by: [Signature]
12	Released by: [Signature]

Units: mm [inches]	
Date:	11/13
Drawn by:	HATTELAND TECHNOLOGY
Checked by:	HATTELAND TECHNOLOGY
Released by:	HATTELAND TECHNOLOGY
Approved by:	HATTELAND TECHNOLOGY
Color code:	
Revision:	
Drawing number:	
Product name:	
Product number:	



This document is the property of Hatteland Technology AS. This document and any authorized reproduction thereof, must not be used in any way against the interest of Hatteland Technology AS. Any authorized reproduction, in whole or in part, must include this legend. Hatteland Technology AS Proprietary information. Not to be distributed to any third party without written permission.

# Technical Drawings - JH 19VED STD-B1

Dimensions might be shown with or without decimals and indicated as mm [inches]. Tolerance on drawings is +/- 1mm. For accurate measurements, check relevant DWG file.

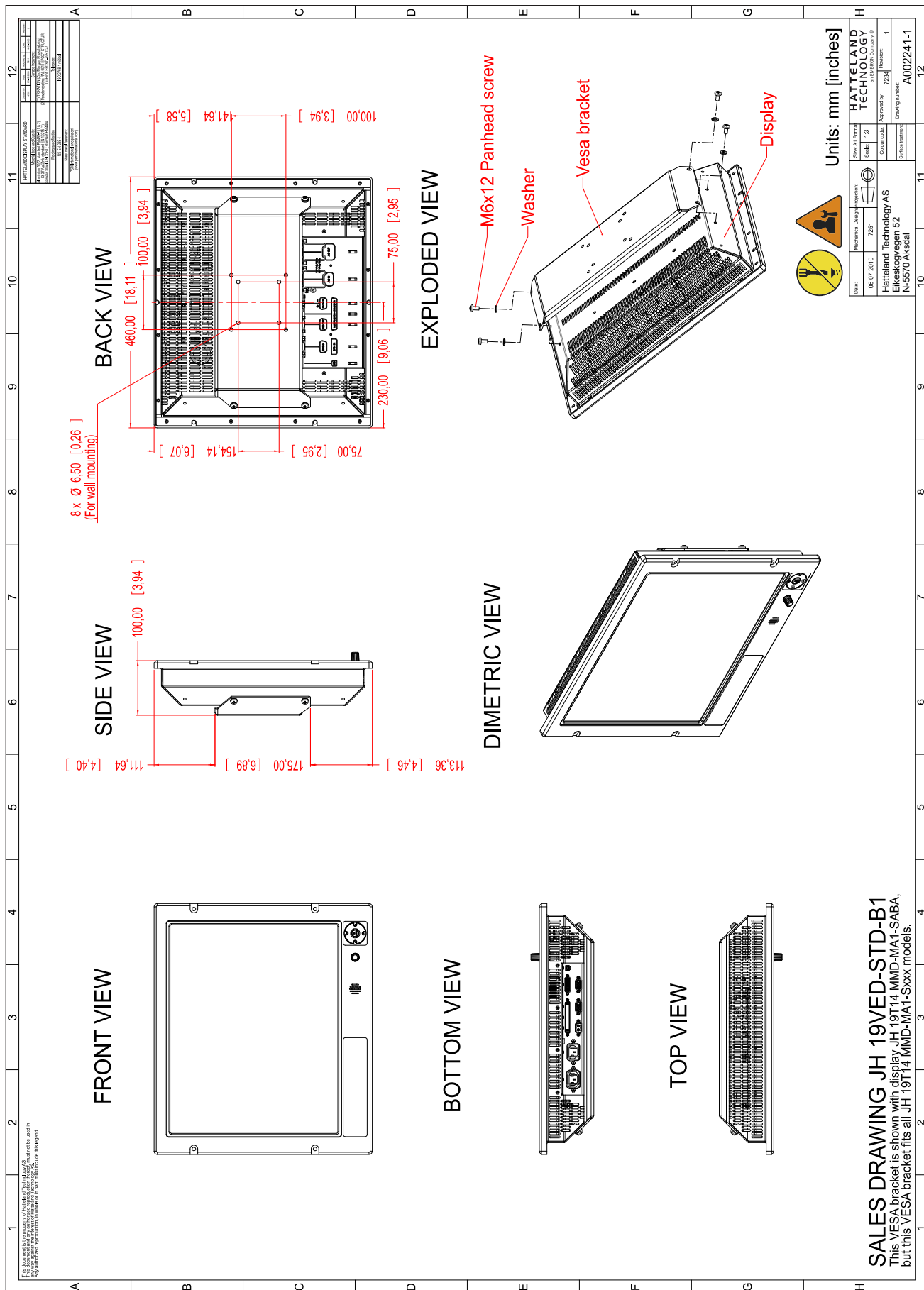

This document is the property of Hatteland Technology AS. This document and any authorized reproduction thereof, must not be used in any way against the interest of Hatteland Technology AS. Any authorized reproduction, in whole or in part, must include this legend. Hatteland Technology AS Proprietary information. Not to be distributed to any third party without written permission.

# Technical Drawings - JH 20VED STD-A1

Dimensions might be shown with or without decimals and indicated as mm [inches]. Tolerance on drawings is +/- 1mm. For accurate measurements, check relevant DWG file.

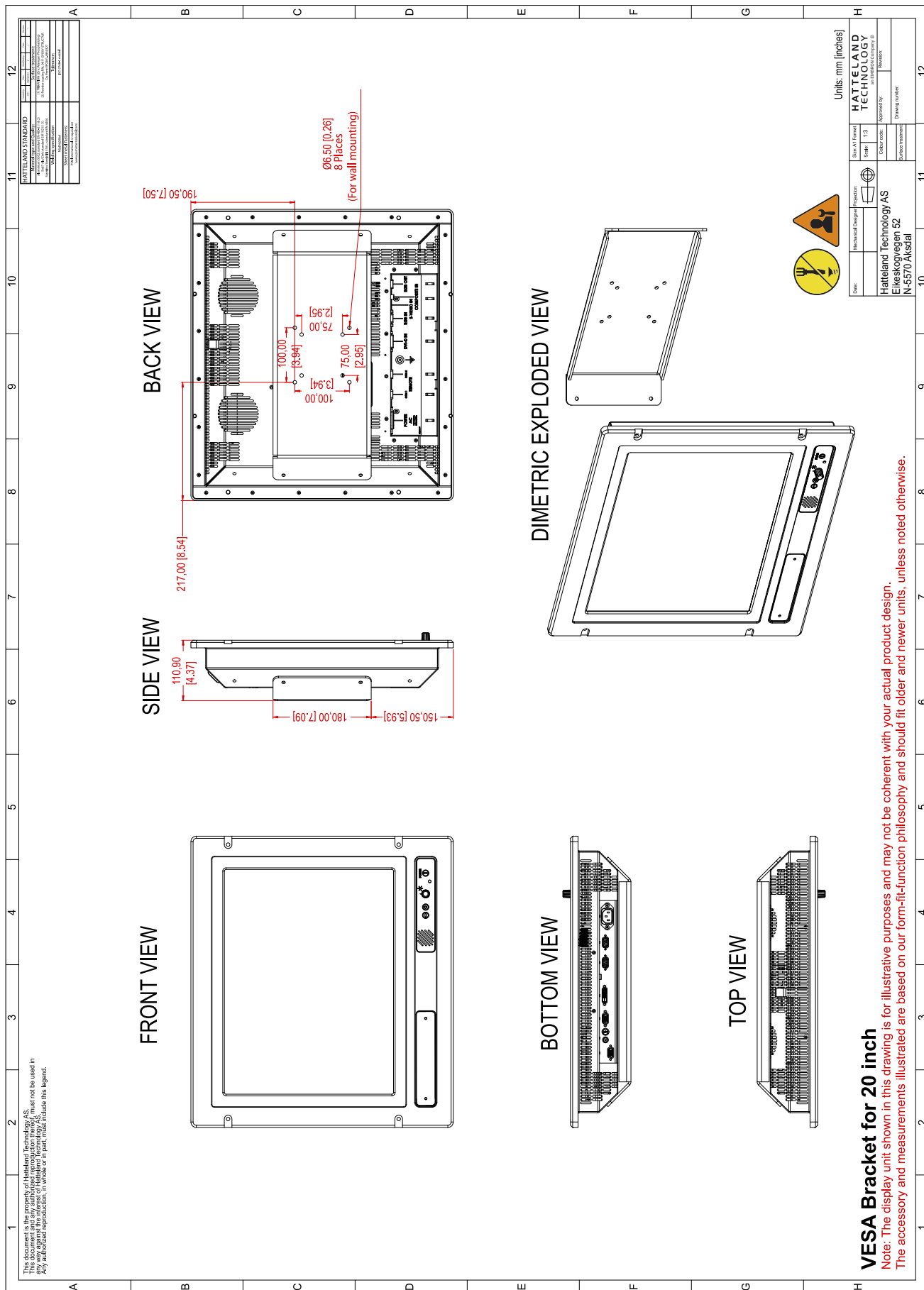

This document is the property of Hatteland Technology AS. This document and any authorized reproduction thereof, must not be used in any way against the interest of Hatteland Technology AS. Any authorized reproduction, in whole or in part, must include this legend. Hatteland Technology AS Proprietary information. Not to be distributed to any third party without written permission.

# Technical Drawings - JH 23VED STD-A1

Dimensions might be shown with or without decimals and indicated as mm [inches]. Tolerance on drawings is +/- 1mm. For accurate measurements, check relevant DWG file.

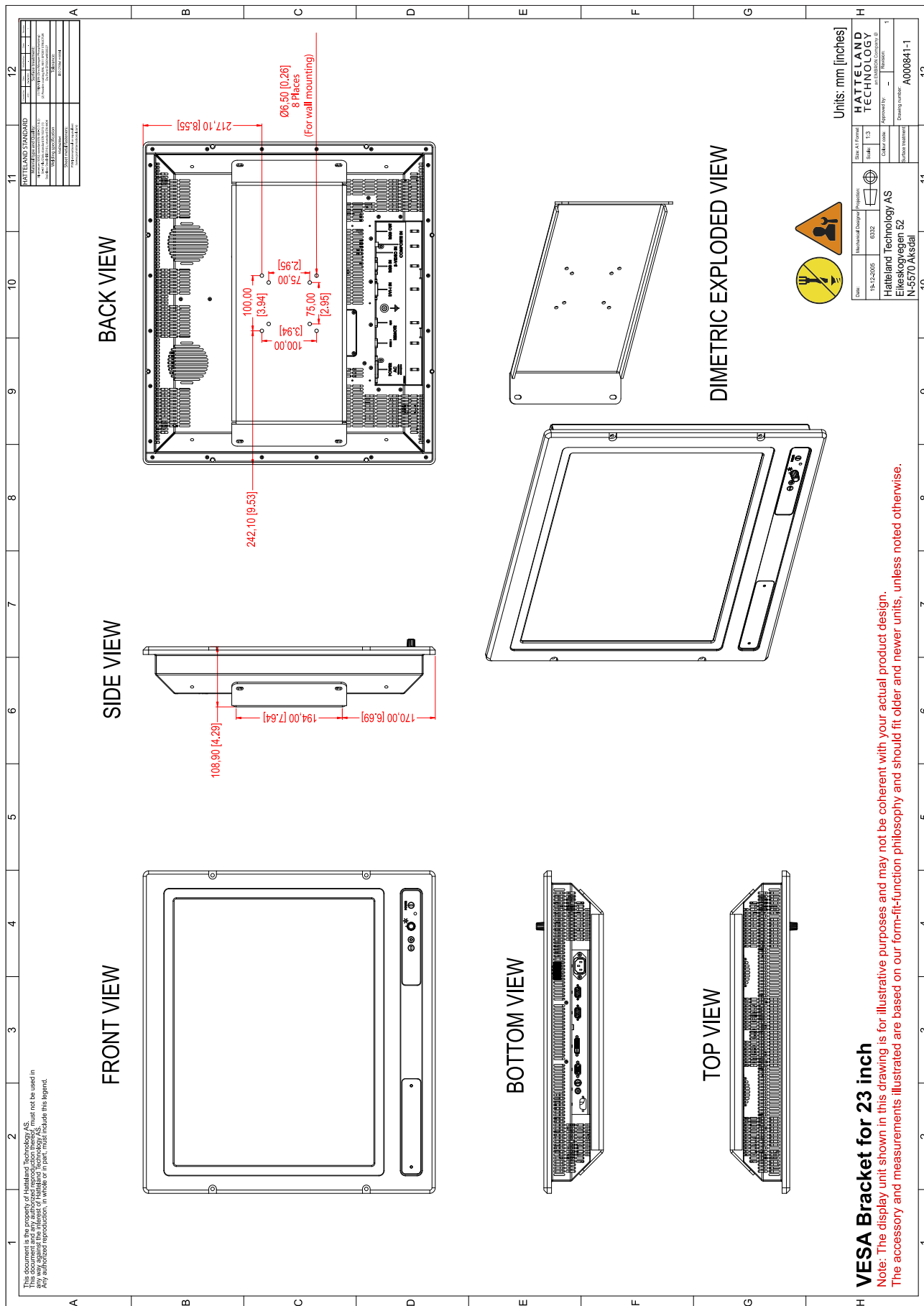

This document is the property of Hatteland Technology AS. This document and any authorized reproduction thereof, must not be used in any way against the interest of Hatteland Technology AS. Any authorized reproduction, in whole or in part, must include this legend. Hatteland Technology AS Proprietary information. Not to be distributed to any third party without written permission.

# Technical Drawings - JH 15TWC STD-A1

Dimensions might be shown with or without decimals and indicated as mm [inches]. Tolerance on drawings is +/- 1mm. For accurate measurements, check relevant DWG file.

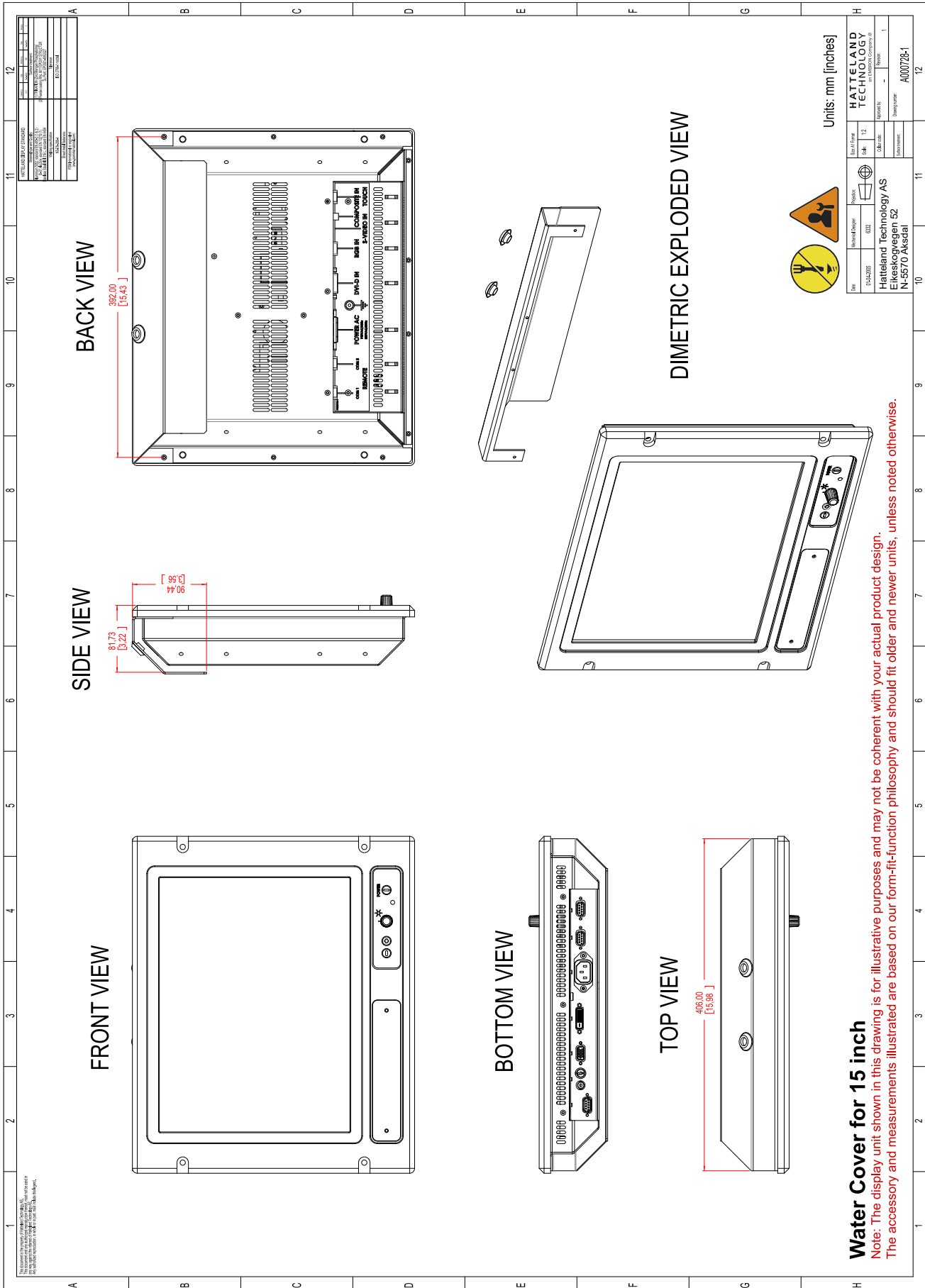

This document is the property of Hatteland Technology AS. This document and any authorized reproduction thereof, must not be used in any way against the interest of Hatteland Technology AS. Any authorized reproduction, in whole or in part, must include this legend. Hatteland Technology AS Proprietary information. Not to be distributed to any third party without written permission.

# Technical Drawings - JH 19TWC STD-B1

Dimensions might be shown with or without decimals and indicated as mm [inches]. Tolerance on drawings is +/- 1mm. For accurate measurements, check relevant DWG file.

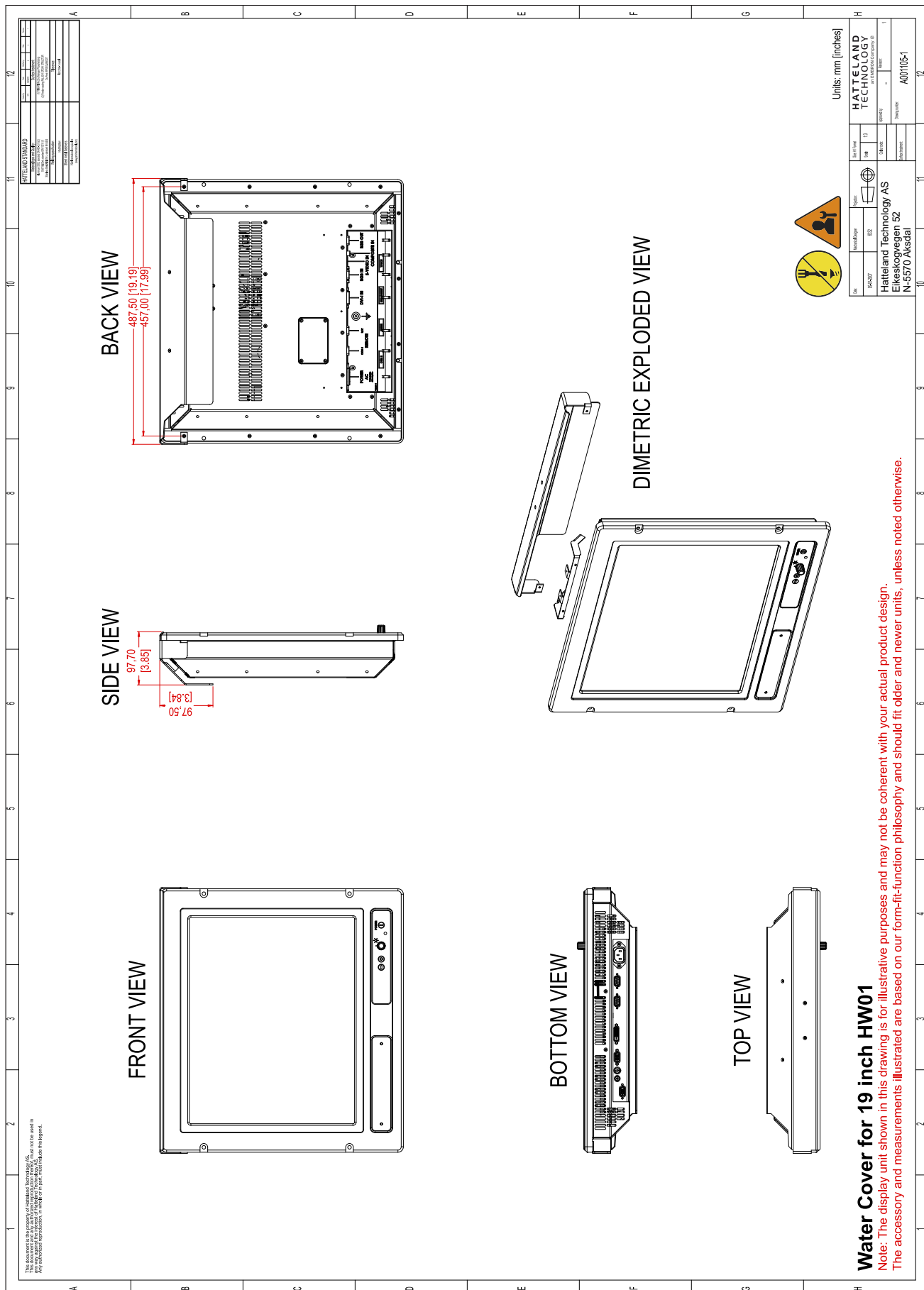

This document is the property of Hatteland Technology AS. This document and any authorized reproduction thereof, must not be used in any way against the interest of Hatteland Technology AS. Any authorized reproduction, in whole or in part, must include this legend. Hatteland Technology AS Proprietary information. Not to be distributed without written permission.

# Technical Drawings - JH 19TWC STD-C1

Dimensions might be shown with or without decimals and indicated as mm [inches]. Tolerance on drawings is +/- 1mm. For accurate measurements, check relevant DWG file.

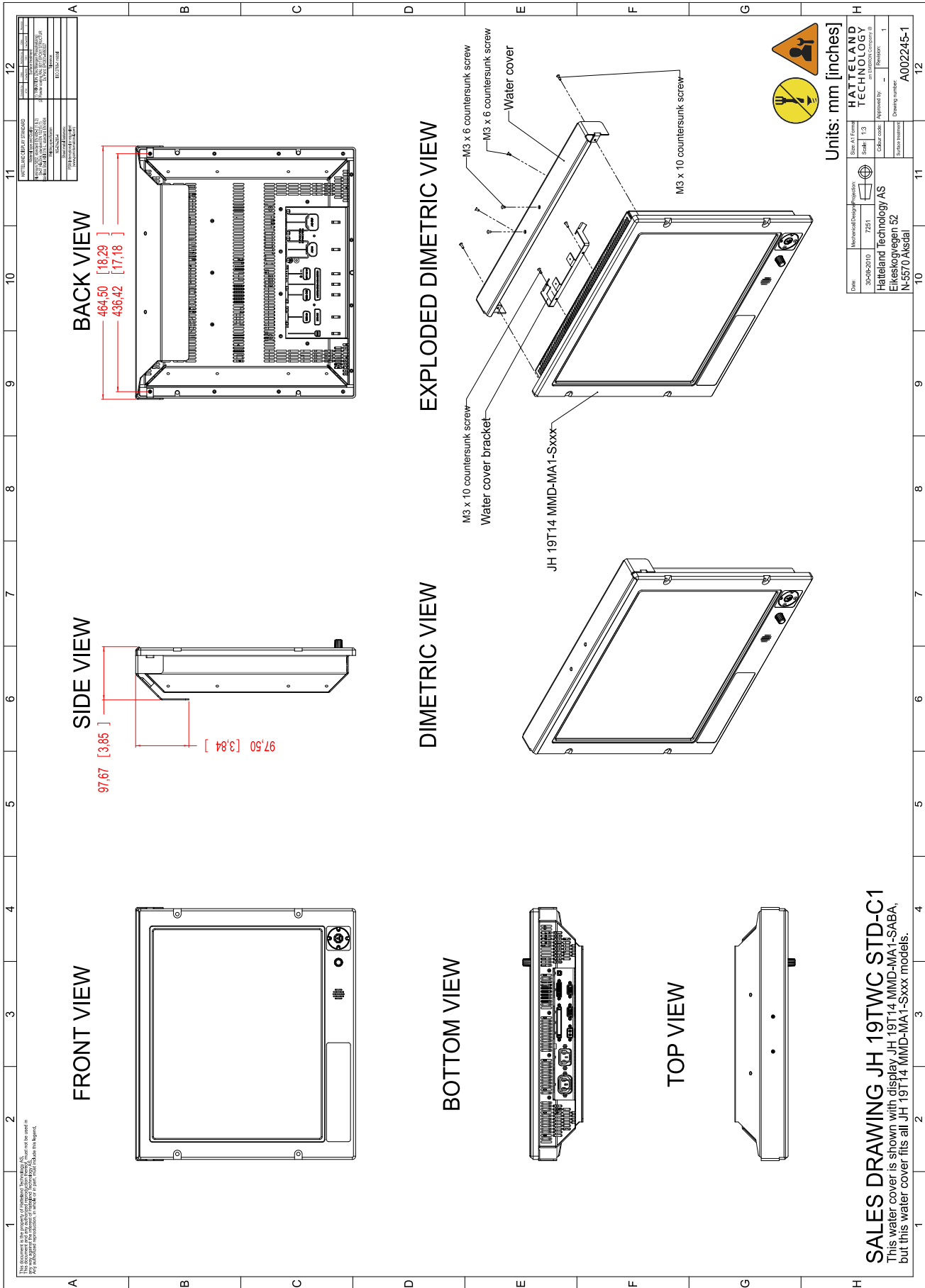

This document is the property of Hatteland Technology AS. This document and any authorized reproduction thereof, must not be used in any way against the interest of Hatteland Technology AS. Any authorized reproduction, in whole or in part, must include this legend. Hatteland Technology AS Proprietary information. Not to be distributed to any third party without written permission.

# Technical Drawings - JH 20TWC STD-B1

Dimensions might be shown with or without decimals and indicated as mm [inches]. Tolerance on drawings is +/- 1mm. For accurate measurements, check relevant DWG file.

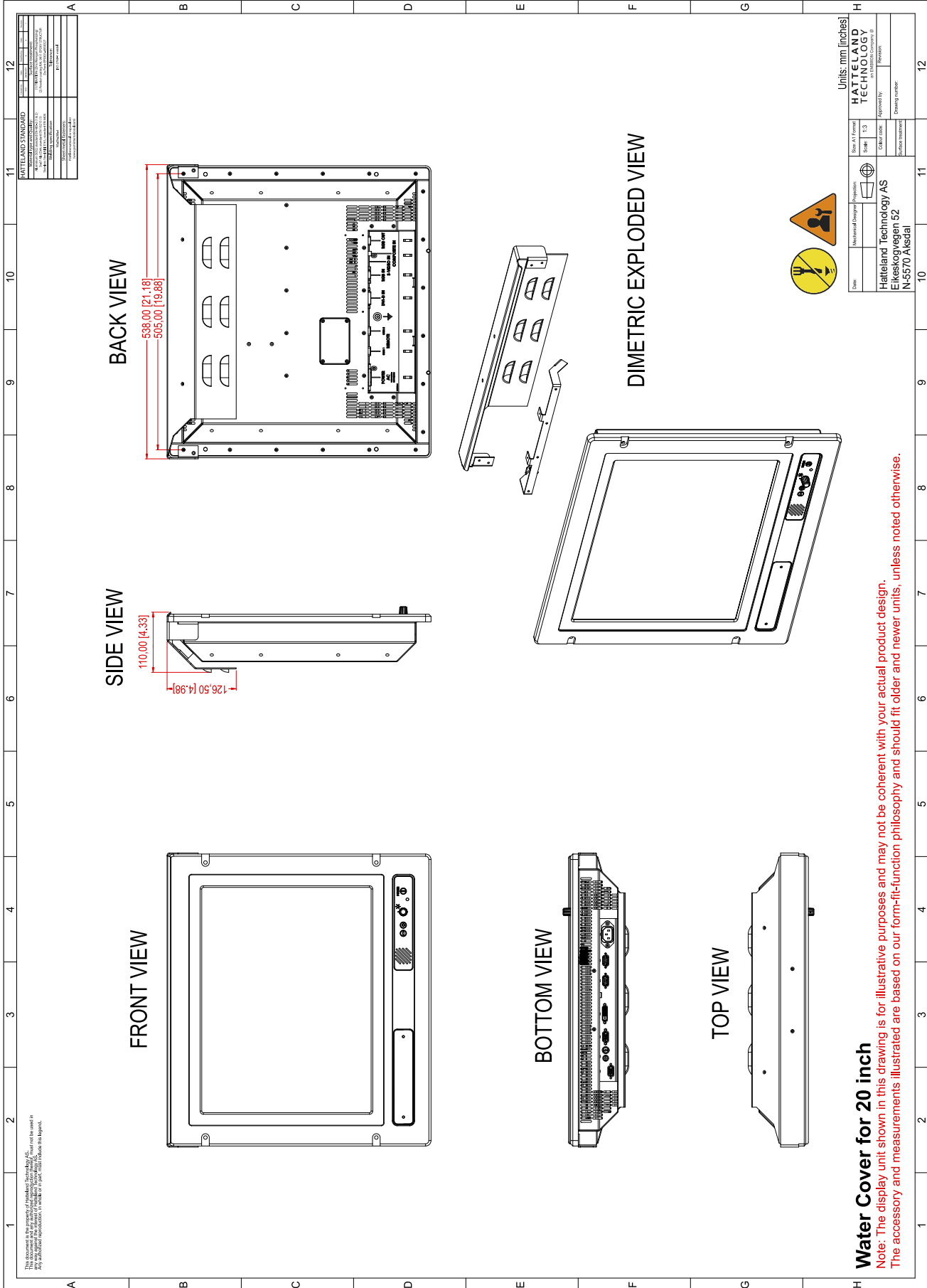

This document is the property of Hatteland Technology AS. This document and any authorized reproduction thereof, must not be used in any way against the interest of Hatteland Technology AS. Any authorized reproduction, in whole or in part, must include this legend. Hatteland Technology AS Proprietary information. Not to be distributed to any third party without written permission.

# Technical Drawings - JH 23TWC STD-A1

Dimensions might be shown with or without decimals and indicated as mm [inches]. Tolerance on drawings is +/- 1mm. For accurate measurements, check relevant DWG file.

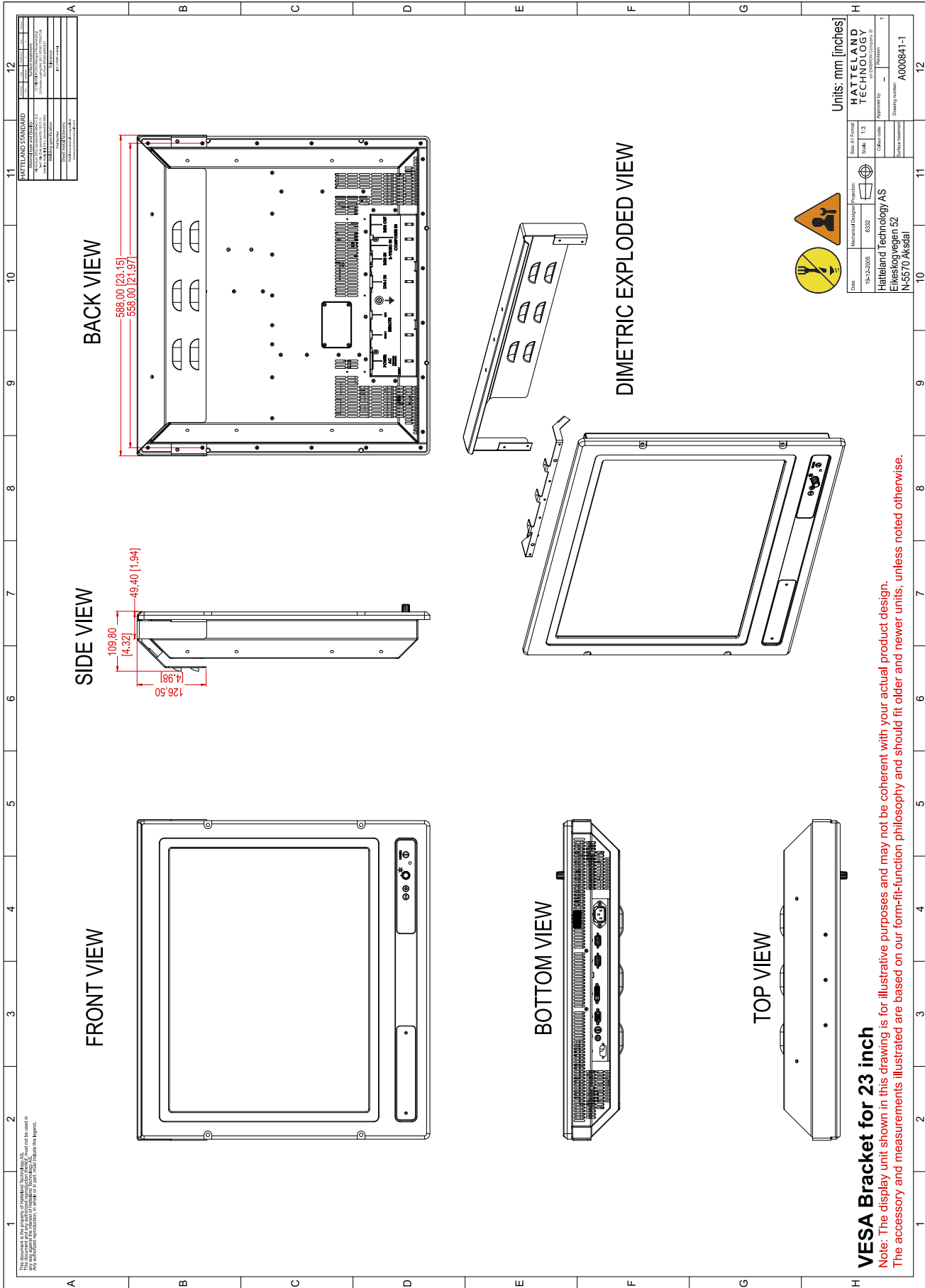

This document is the property of Hatteland Technology AS. This document and any authorized reproduction thereof, must not be used in any way against the interest of Hatteland Technology AS. Any authorized reproduction, in whole or in part, must include this legend. Hatteland Technology AS Proprietary information. Not to be distributed to any third party without written permission.



# Appendixes

# Pinout Assignments

Connectors illustrated here are either standard by factory default or may be available (through factory customization). Note that some combinations may not be possible due to space restrictions. List also valid for customized models. All pin out assignments are seen from users Point of View (POV) while looking straight at the connector. Please review the dedicated datasheet or technical drawings for your actual unit to identify and determine the presence of desired connector. Detailed information about Housing Connectors (terminal blocks) can be found earlier in this manual.

## 18/24/24+5 pin DVI-D, DVI-I, Single Link, Dual Link Combined Female

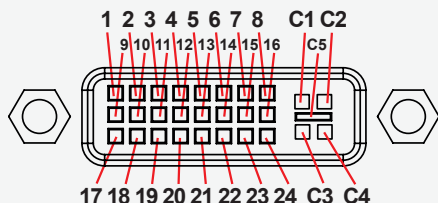

PIN 01	T.M.D.S. Data2 - (Digital - RED link 1)
PIN 02	T.M.D.S. Data2 + (Digital + RED link 1)
PIN 03	T.M.D.S. Data2/4 Shield
PIN 04	T.M.D.S. Data4 - (Digital - GREEN link 2)
PIN 05	T.M.D.S. Data4 + (Digital + GREEN link 2)
PIN 06	DDC Clock
PIN 07	DDC Data
PIN 08	Analog Vertical Sync (DVI-I only)
PIN 09	T.M.D.S. Data1 - (Digital - GREEN link 1)
PIN 10	T.M.D.S. Data1 + (Digital + GREEN link 1)
PIN 11	T.M.D.S. Data1/3 Shield
PIN 12	T.M.D.S. Data3 - (Digital - BLUE link 2)
PIN 13	T.M.D.S. Data3 + (Digital + BLUE link 2)
PIN 14	+5V Power (for standby mode)
PIN 15	Ground (for +5V and analog sync)
PIN 16	Hot Plug Detect
PIN 17	T.M.D.S. Data0 - (Digital - BLUE link 1) and digital sync.
PIN 18	T.M.D.S. Data0 + (Digital + BLUE link 1) and digital sync.
PIN 19	T.M.D.S. Data0/5 Shield
PIN 20	T.M.D.S. Data5 - (Digital - RED link 2)
PIN 21	T.M.D.S. Data5 + (Digital - RED link 2)
PIN 22	T.M.D.S. Clock Shield
PIN 23	T.M.D.S. Clock + (Digital clock + (Links 1 and 2))
PIN 24	T.M.D.S. Clock - (Digital clock - (Links 1 and 2))
PIN C1	Analog RED
PIN C2	Analog GREEN
PIN C3	Analog BLUE
PIN C4	Analog Horizontal Sync.
PIN C5	Analog Ground (return for RGB signals)

DDC = Display Data Channel.

T.M.D.S = Transition Minimized Differential Signal

PIN C1,C2,C3,C4 = Only present on DVI-I connectors.

NOTE: Connector shows a DUAL LINK design, but some units may not support it. Only units with 1920x1200 or more in resolution require / support DUAL LINK.

## 8-pin RJ45 10/100/1000Mbps LAN/Ethernet

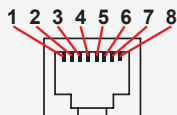

PIN 01	D0P+	Differential Pair 0 (Positive)
PIN 02	D0N-	Differential Pair 0 (Negative)
PIN 03	D1P+	Differential Pair 1 (Positive)
PIN 04	D2P+	Differential Pair 2 (Positive)
PIN 05	D2N-	Differential Pair 2 (Negative)
PIN 06	D1N-	Differential Pair 1 (Negative)
PIN 07	D3P+	Differential Pair 3 (Positive)
PIN 08	D3N-	Differential Pair 3 (Negative)

## Analog RGB/VGA, 15-pin DSUB High Density Female

Onboard or via DVI-4 adapter

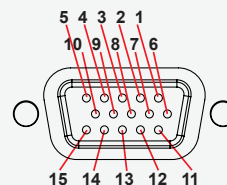

PIN 01	RED	Red, analog
PIN 02	GREEN	Green, analog
PIN 03	BLUE	Blue, analog
PIN 04	ID2/RES	Reserved for monitor ID bit 2 (grounded)
PIN 05	GND	Digital ground
PIN 06	RED RTN	Analog ground red
PIN 07	GREEN RTN	Analog ground green
PIN 08	BLUE RTN	Analog ground blue
PIN 09	KEY/PWR	+5V power supply for DDC (optional)
PIN 10	GND	Digital ground
PIN 11	ID0/RES	Reserved for monitor ID bit 0 (grounded)
PIN 12	ID1/SDA	DDC serial data
PIN 13	HSYNC.	Horizontal sync or composite sync, input
PIN 14	VSYNC.	Vertical sync, input
PIN 15	ID3/SCL	DDC serial clock

## 20-pin DisplayPort (DP) Female

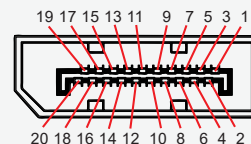

PIN 01	ML Lane 0 (p) - Lane 0 (positive)
PIN 02	GND - Ground
PIN 03	ML Lane 0 (n) - Lane 0 (negative)
PIN 04	ML Lane 1 (p) - Lane 1 (positive)
PIN 05	GND - Ground
PIN 06	ML Lane 1 (n) - Lane 1 (negative)
PIN 07	ML Lane 2 (p) - Lane 2 (positive)
PIN 08	GND - Ground
PIN 09	ML Lane 2 (n) - Lane 2 (negative)
PIN 10	ML Lane 3 (p) - Lane 3 (positive)
PIN 11	GND - Ground
PIN 12	ML Lane 3 (n) - Lane 3 (negative)
PIN 13*	CONFIG1 - connected to Ground*
PIN 14*	CONFIG2 - connected to Ground*
PIN 15	AUX CH (p) - Auxiliary Channel (positive)
PIN 16	GND - Ground
PIN 17	AUX CH (n) - Auxiliary Channel (negative)
PIN 18	Hot Plug - Hot Plug Detect
PIN 19	Return - Return for Power
PIN 20	DP_PWR - Power for connector (3.3 V 500 mA)

\*Pins 13 and 14 may either be directly connected to ground or connected to ground through a pull-down device. This is the pinout for source-side connector, the sink-side connector pinout will have lanes 0-3 reversed in order; i.e., lane 3 will be on pin 1(n) and 3(p) while lane 0 will be on pin 10(n) and 12(p).

# Pinout Assignments

## Potentiometer Control, 9-pin DSUB Male

**Warning:** Do not connect or disconnect cables/connectors to this connector while the Display unit is powered on. Failure to do so may result in damaged electronics inside the Display Unit

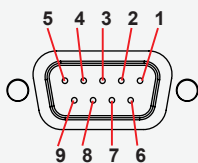

PIN 01	+5V	+5V out
PIN 02	PWR	Power On / Off
PIN 03	Res.	Reserved, do not connect
PIN 04	Aref	For potentiometer
PIN 05	+12V	+12V out
PIN 06	BRT_POT	Potentiometer in
PIN 07	BRT -	Button in
PIN 08	BRT+	Button in
PIN 09	GND	Ground

Potentiometer shall be **10kΩ LINEAR**. Connect like the illustrations shown below:

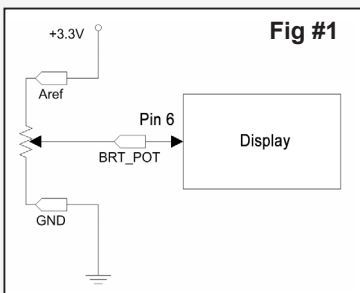

**Fig #1**

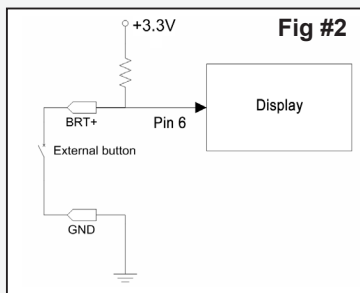

**Fig #2**

The BRT+ and BRT- can be used for controlling the brilliance by using external buttons. Example for the BRT+ input in figure #2:

### Building your own cable:

**Note:** Requires soldering and assembly. It is expected that the technician has experience in electronics, soldering and assembling cables and connectors.

Pin 1 on product

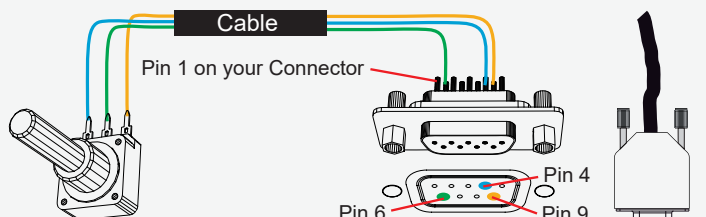

External Potentiometer  
**Note: Example only**

9-pin DSUB Female  
**Note Orientation!**  
Add Back Shell

Use a cable that contains at least 3 wires (not 3 single wires). Heat Shrink Tubes must be applied to soldered wire/pins. Test connection (beep) with Voltage Meter. Test connection between power pin and other pins to ensure no short circuit is present prior to connecting cable and power on Display unit. Finally, the 9-pin DSUB must be covered by a back shell.

In order to activate the external Potentiometer control, the internal "POT" - Backlight Control Interface selection" command has to be set first via our SCOM (Serial Communication Control Interface).

Usage for SCOM: Review the dedicated Technical Manual available from our website: <https://www.hattelandtechnology.com/hubfs/pdfget/inb100018-6.htm>

## External Power ON/OFF Control, 9-pin DSUB Male

**Warning:** Do not connect or disconnect cables/connectors to this connector while the Display unit is powered on. Failure to do so may result in damaged electronics inside the Display Unit

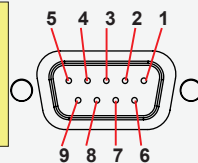

PIN 01	+5V	+5V out
PIN 02	PWR	Power On / Off
PIN 03	Res.	Reserved, do not connect
PIN 04	Aref	For potentiometer
PIN 05	+12V	+12V out
PIN 06	BRT_POT	Potentiometer in
PIN 07	BRT -	Button in
PIN 08	BRT+	Button in
PIN 09	GND	Ground

External Power Button must be of "Push Button" type.

Instant-On. To turn off unit, Press & Hold down for 3 seconds.

### Building your own Push Button for External Power Button:

**Note:** Requires soldering and assembly. It is expected that the technician has experience in electronics, soldering and assembling cables and connectors.

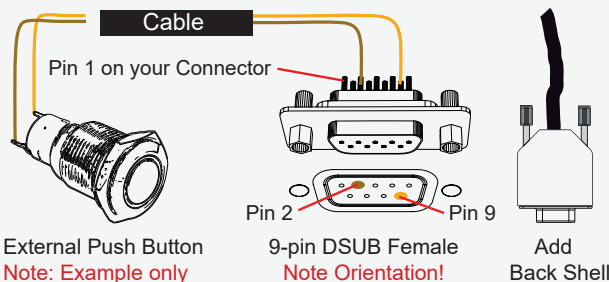

External Push Button  
**Note: Example only**

9-pin DSUB Female  
**Note Orientation!**

Add Back Shell

Use a cable that contains at least 2 wires (not 2 single wires). Heat Shrink Tubes must be applied to soldered wire/pins. Test connection (beep) with Voltage Meter.

**In order to activate the external Power ON/OFF control it must be enabled:**  
Via OSD Menu: "OSD Miscellaneous>External Power Button" and set to Enable.  
or  
Via SCOM (Serial Communication Control Interface):  
"MCC" - OSD Control Functionality -> "External Power Button (0x74)".

Usage for SCOM: Review the dedicated Technical Manual available from our website: <https://www.hattelandtechnology.com/hubfs/pdfget/inb100018-6.htm>

### 1-pin RCA/BNC COMP. VIDEO Female



### 2-pin Terminal Block 5.08 - DC Power Input

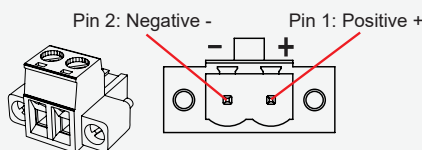

# Pinout Assignments

## 10-pin RS-422 / RS-485 Module

"RS-422/RS-485 SCOM + Buzzer"

(Internal Buzzer can be controlled externally)

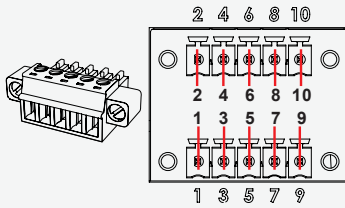

PIN 01*	RxD+	Receive Data Positive
PIN 02	GND	Ground
PIN 03*	RxD-	Receive Data Negative
PIN 04	+5V	+5V Out
PIN 05*	TxD+	Transmit Data Positive
PIN 06**	BUZ-	Buzzer Control Negative
PIN 07*	TxD-	Transmit Data Negative
PIN 08**	BUZ+	Buzzer Control Positive
PIN 09	GNDR	Ground 100Ω
PIN 10	GND	Ground

\*Pin 1,3,5,7 = RS-485 Full Duplex (4-wire)

\*Pin 5,7 = RS-485 Half Duplex (2-wire)

\*\*See notes in blue.

### Suggested "Buzzer" Control Logic inside Computer/System:

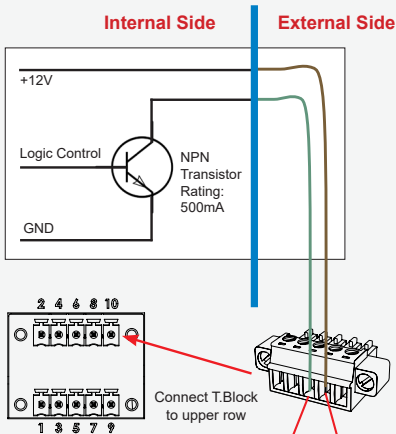

Note:

To ensure that EMC requirements are met, we recommend that the cable is screened and screen is terminated/grounded at both ends with as short as possible pig tail.

For Military/Naval use: +12V line from customer system should be low pass filter or else the power ripple may cause radiated emission to fail.

Use a cable that contains at least 2 wires (not 2 single wires). Test connection (beep) with Voltage Meter. Wires may be combined if using RS-422/485 COM as well.

- Display Unit needs external power connected to turn buzzer on. (Any logic power state).

## Serial COM RS-232 non-isolated. 9-pin DSUB Male

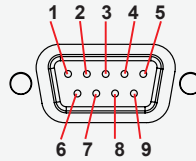

PIN 01	DCD	Data Carrier Detect
PIN 02	RxD	Receive Data
PIN 03	TxD	Transmit Data
PIN 04	DTR	Data Terminal Ready
PIN 05	GND	Signal Ground
PIN 06	DSR	Data Set Ready
PIN 07	RTS	Request To Send
PIN 08	CTS	Clear To Send
PIN 09	RI	Ring Indicator

Connector is primarily defined for Touch Screen communication.

## 4-pin USB TYPE A

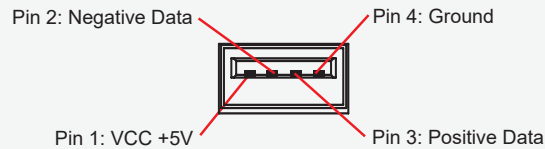



# IEC62368 policy for Hatteland Technology products

## Introduction





According to the requirements of EN 62368-1:2014.

The tables below refers to the policies for opening, servicing and installation of the unit(s) referred to in this manual. This equipment is designed to be used as a fixed installation and to be sold through special sales channels for professional use.

## Based on requirements EN 62368-1:2014 and IEC 62368-1:2018

Defenition	Description
<b>Ordinary person/ Sailor/End-User</b> 	Ordinary person is the term applied to all persons other than instructed persons and skilled persons. Ordinary persons include not only users of the equipment, but also all persons who may have access to the equipment or who may be in the vicinity of the equipment. Under normal operating conditions or abnormal operating conditions, ordinary persons should not be exposed to parts comprising energy sources capable of causing pain or injury. Under a single fault condition, ordinary persons should not be exposed to parts comprising energy sources capable of causing injury.
<b>Instructed person</b> 	Instructed person is a term applied to persons who have been instructed and trained by a skilled person, or who are supervised by a skilled person, to identify energy sources that may cause pain and to take precautions to avoid unintentional contact with or exposure to those energy sources. Under normal operating conditions, abnormal operating conditions or single fault conditions, instructed persons should not be exposed to parts comprising energy sources capable of causing injury.
<b>Skilled person</b> 	Skilled person is a term applied to persons who have training or experience in the equipment technology, particularly in knowing the various energies and energy magnitudes used in the equipment. Skilled persons are expected to use their training and experience to recognize energy sources capable of causing pain or injury and to take action for protection from injury from those energies. Skilled persons should also be protected against unintentional contact or exposure to energy sources capable of causing injury,

# IEC62368 policy for Hatteland Technology products

Authority	Description
<b>Children</b> 	This equipment is not suitable for use in locations where children are likely to be present.
<b>Ordinary person/ Sailor/End-User</b> 	Not allowed to open unit. Not allowed to install the unit. Not allowed to terminate/connect cables to the unit.
<b>Instructed person</b> 	Allowed to open hatches/latches which does not require tools, such as Disktrays. Allowed to open "battery-hatch" to change the battery even if tools are required. Allowed to install the unit. Allowed to terminate/connect cables to the unit indoors.
<b>Skilled person</b> 	Allowed to open and disassemble the unit.  Allowed to install the unit. Allowed to terminate/connect cables to the unit indoors and outdoors. Allowed to terminate/connect earth/ground wire.  Note: Be aware that additional definition for "skilled person" may apply, country dependent.

Conditions	Description
<b>AC power net Class</b>	Class 1. Pollution degree 2. Over voltage category 2.
<b>Transient requirement</b>	External circuits are considered to be installed wholly within the same building structure.
<b>Battery</b>	Obligated to use battery specified for the product.
<b>Altitude</b>	Products are designed for a max operating altitude of 2000m.

Installation	Description
<b>Mounting brackets</b>	Only bracket defined/specified for the unit is allowed.
<b>AC power cord</b>	When installed it shall be possible to disconnect the unit from the AC power net i.e. possible to reach AC connector.
<b>Transient requirement</b>	External circuits are considered to be installed wholly within the same building structure.
<b>Earthing</b>	Obligated to use defined earthing material/method specified for the unit.  Minimum protective bonding conductor size of copper conductors: Wire: Minimum 1,5mm <sup>2</sup> but Hatteland Technology recommends 2,5mm <sup>2</sup> (AWG12) marked yellow/green.
<b>Outdoor</b>	Units with IP66/67-rated fronts can be used in outside environments, provided that the console they are fitted in fulfil certain requirements. <ul style="list-style-type: none"> <li>- There must be a fully water/dustproof seal between the IP66 front and the console.</li> <li>- Dust/water ingress protection of console. (Unit/product is rated for pollution degree 2).</li> <li>- Humidity/condensation control in console.</li> <li>- Thermal management in console (so units can operate within rated temperature range).</li> </ul> Units with IP20/IP22 shall not be used outdoor.
<b>Outdoor Installation</b>	Appropriate RCD with ground current rating of 20mA or less shall be used.

## Basic Trouble-shooting

### GENERAL ISSUES FOR TFT PANEL BASED PRODUCTS

Note: Applies for a range of various products. This is only meant as a general guide.

#### **NO PICTURE / LED BEHAVIOUR:**

If there is no light at all in the LED at the FRONT, check power cables. If the LED in front is green, then check if the brightness is set/adjusted to max brightness. Lack of image is most likely to be caused by incorrect connection, lack of power or wrong BIOS settings.

#### **SCROLLING / UNSTABLE IMAGE:**

Signal cable may not be completely connected to computer or TFT display. Check the pin assignments and signal timings of the display and your video card with respect to recommended timing and pin assignments. Make sure that the video card is compatible and that it is properly seated / installed on the computer.

#### **DISPLAY AREA IS NOT CENTERED / SIZED CORRECTLY**

Make sure that a supported video mode has been selected on the display, or on the video card / system. If it is impossible to position the image correctly, i.e. the image adjustment controls will not move the image far enough, then test it again using another graphics card for the PC system. This situation may occur with a custom graphics card that is not close to standard timings or if something is in the graphics line that may be affecting the signal, such as a signal splitter (please note that normally a signal splitter will not have any adverse effect). If it is impossible to change to the correct resolution/color depth, check if you have the right graphics driver installed in your system.

#### **IMAGE APPEARANCE:**

A faulty TFT panel can have black lines, pixel errors, failed sections, flickering or flashing image. Incorrect graphic card refresh rate, resolution or interlaced mode will probably cause the image to be the wrong size, it may scroll, flicker badly or possibly even no image is present. Sparkling on the display may be a faulty TFT panel signal cable, and it needs service attention.

VGA Signal Only: Horizontal interference can usually be corrected by adjusting the PHASE (OSD menu).  
Vertical interference can usually be corrected by adjusting the FREQUENCY (OSD menu).

#### **DEW CONDENSATION BEHIND GLASS:**

Note that this problem will not occur on bonded products. For non-bonded products, do the following:  
Power on the TFT product and set brightness to 100%. Turn off any automatic screensavers on PC or similar. During minutes the dew will be gone. To speed up the process, use a fan heater for a reasonable time. Do not overheat the unit.

# HATTELAND TECHNOLOGY

an EMBRON Company 

## Declaration of Conformity

We, manufacturer, **Hatteland Technology AS**, Eikeskogvegen 52, N-5570 Aksdal, Norway

declare under our sole responsibility that the JH MMD, JH MMC, JH STD, JH MIL, HM NMD, HM MIL, HM CMD, HT STD, HD MMD, HD MVD, HM MMD, HM XRD, HM RMD, HT MMC, HD MMC and HT/HM (computers) product ranges is in conformity with the following standards in accordance with the EMC Directive.

Low Voltage Directive 2014/35/EU  
EN 60950:2006/ A2:2013  
EMC Directive 2014/30/EU  
EN 55032:2012 Class A / AC:2011 Class A  
EN 55024:2010

Signature:   
Frode Grindheim  
Vice President Product Management  
Aksdal, Norway



CE MARK FIRST AFFIXED DATE (11 March 2010)

Signature:   
Arne Kristiansen  
Site Manager - Test & Commission Division  
Oslo, Norway

## Declaration of Conformity

We, manufacturer, **Hatteland Technology AS**, Eikeskogvegen 52, N-5570 Aksdal, Norway  
declare under our sole responsibility that the JH MMD, JH MMC, JH STD, JH MIL, HM NMD, HM MIL, HM CMD, HT STD, HD MMD, HD MVD, HM MMD, HM XRD, HM RMD, HT MMC, HD MMC and HT/HM (computers) product ranges is in conformity with IEC 60945 4th (EN 60945:2002) and IACS E10 (where applicable)

# HATTELAND TECHNOLOGY

an EMBRON Company 

## Declaration of Conformity

We, manufacturer, **Hatteland Technology AS**, Eikeskogvegen 52, N-5570 Aksdal, Norway

declare under our sole responsibility that the products listed below comply with  
FCC 47 CFR Part 15, Subpart B, Class A:

JH MMD, JH MMC, JH STD, JH MIL, HM NMD, HM MIL, HM CMD, HT STD, HD MMD, HD MVD, HM MMD, HM XRD, HM RMD, HT MMC, HD MMC and HT/HM (computers) product ranges

Note: This equipment has been tested and found to comply with the limits for a Class A digital device, pursuant to part 15 of the FCC Rules. These limits are designed to provide reasonable protection against harmful interference when the equipment is operated in a commercial environment. This equipment generates, uses, and can radiate radio frequency energy and, if not installed and used in accordance with the instruction manual, may cause harmful interference to radio communications. Operation of this equipment in a residential area is likely to cause harmful interference in which case the user will be required to correct the interference at his own expense.

Signature:   
Frode Grindheim  
Vice President Product Management  
Aksdal, Norway



FCC MARK FIRST AFFIXED DATE (16 February 2012)

Signature:   
Arne Kristiansen  
Site Manager - Test & Commission Division  
Oslo, Norway

# Return Of Goods Information

## Return of goods:

*(Applies not to warranty/normal service/repair of products)*

Hatteland Technology referenced as “manufacturer” in this document.

Before returning goods, please contact your system supplier before sending anything directly to manufacturer. When you return products after loan, test, evaluation or products subject for credit, you must ensure that all accessories received from our warehouse are returned. This applies to cables, powermodules and additional equipment except screws or similar, user manual, datasheets or other written paper documents. Furthermore, the product must not have any minor / medium or severe scratches, chemical spills or similar on the backcover, front frame or glass.

This is required in order to credit the invoice 100%. Missing parts will not be subject for credit, and you will not get total credit for returned product. You will either be charged separately, or the amount is withdrawn from the credit. If you decide to ship the missing items later on, you will get 100% credit for that particular invoice or items received at manufacturer incoming goods control. Please contact our Repair Centre if additional questions or review the following links at bottom of page for more information online.



## Handling and packing units for return/credit

To prevent damage during shipping and transportation, respect the guidelines below.

### Make sure you surround the product with the following material (whenever possible):

Use the original packaging from manufacturer, firm foam material, bubble wrap, lots of PadPack paper or foam chips/polyester wrapped in sealed plastic bags. Please make sure that the unit is protected with a surrounding plastic bag to prevent dust accumulation around the unit.

If you do not have the original packaging or are uncertain as to how to secure the unit properly, please consider seeking advice from nearby shipping or transportation offices, if in doubt!

Do not under any circumstances use loose foam chips, expanded polyester, clothes, cardboard with sharp edges/spikes, too little or nothing to secure the unit inside the box. Do not use cardboard boxes that are clearly too weak or not suitable for securing the unit properly during overseas shipment.

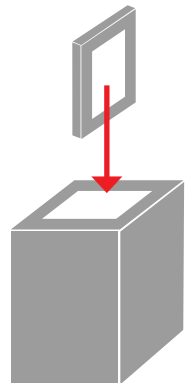

## How to issue a Return merchandise authorization (RMA):

Hatteland Technology requires a pre-registered CDV number prior to sending goods for return. If you do not have an pre-registered CDV number, please visit the links below on how to get one.

<https://www.hattelandtechnology.com/rma-procedure>

Once understood, proceed to registering RMA:

<http://lcm.hatteland-display.com/CustomerRMA/CustomerRMA.aspx>

Additional information:

<https://www.hattelandtechnology.com/legal-documents>

# General Terms and Conditions

As of January 2015, Hatteland Technology AS' "Terms of Sales and Delivery" and "Warranty Terms" have been substituted by the updated "General terms and conditions for sale of goods and performance of additional services" (the "General Terms and Conditions").

Further, from January 2015 onward, the previous "Terms of Sales and Delivery" and "Warranty Terms", as well as other standard terms and conditions, policies and instructions issued by Hatteland Technology AS, will be removed from the User Manuals.

Instead, the updated General Terms and Conditions and the other standard terms and conditions, policies and instructions issued by Hatteland Technology AS will be available via our website only.

Please visit <https://www.hattelandtechnology.com/legal-documents#terms-and-conditions> to review the latest revision

## Long Term Storage Recommendations

For Minimum storage life for Hatteland Technology products, Storage Conditions, Periodic maintenance - test procedure, please visit:

[https://www.hattelandtechnology.com/hubfs/pdf/misc/ind100350-5\\_long\\_term\\_storage\\_recommendations.pdf](https://www.hattelandtechnology.com/hubfs/pdf/misc/ind100350-5_long_term_storage_recommendations.pdf)

## INSTRUCTIONS FOR THE CONSIGNEE

### 1) CONTROL

Control the goods immediately by receipt. Examine the quantity against the invoice/packinglist/shipping documents. Look for outward defects on the packing which may indicate damage on or loss of contents. Control the container and the seals for any defects.

### 2) SECURING EVIDENCE

When defects on the goods have been found, evidence must be secured, and seller must be informed. Call the transporter and point out the defects. Add a description of the defects on the goods receipt, the forwarder's copy of the way-bill or on the driving slip.

### 3) RESCUE

Try to restrict the damage and the loss. Seller will compensate expenses incurred due to reasonable security efforts in addition to damage and loss.

### 4) COMPLAINT

Immediately write a complaint to the transporter or his agent. Immediately forward the complaint to the transporter or his agent, and hold the transporter responsible for the defects. The complaint must be sent at the latest:

- for carriage by sea: within 3 days
- for overland / air transportation within 7 days

### 5) DOCUMENTATION

For any claims the following documentation is required and must be forwarded to the company or their agent: invoice, way-bill and/or bill of landing, and/or statement of arrival, inspection document, besides a copy of the letter of complaint to the transporter.

# Pixel Defect Policy

## PIXEL DEFECT POLICY

### Dot-defects (Bright or dark spots on the panel)

Due to the effect that dot failures are part of the TFT technology such failure occurrence cannot be prevented basically. Even though dot defects usually occur during production process, new defects can appear within the lifespan of a TFT display. Neither the production at LCD-supplier nor the use of an LCD-Monitor after shipment can be influenced by Hatteland Technology. Hence Hatteland Technology cannot be made responsible for such dot failures. However Hatteland Technology understands and accepts the responsibility towards the customers for the delivery of new displays, therefore accepts a limitation on dot defects occurrence on new displays delivered to the customer.

## PRINCIPLES

- a. One pixel consists of 3 dots (Red, Green and Blue)
- b. Dot defects are differentiated between:
  - Bright dot defects: Spot on the panel appear as pixels or sub pixels that are always lit. Non-extinguishing dot.
  - Dark dot defects: Spot on the panel appear as pixels or sub pixels that are always dark (off). Non-lightening dot.
- c. Inspector observes the LCD from normal direction at a distance of 50cm above the worktable. Dark dots are counted under entire white screen. Bright dots are counted under entire black screen.
- d. Dot failures within tolerances below do not qualify for warranty claims.

## PIXEL DEFECT TOLERANCES

Bright dot	≤ 4 dots
Two adjacent bright dots *	≤ 2
Distance between 2 dot defects *	≥ 15mm
Dark dots	≤ 8
Total number of bright or dark dot defects. *	≤ 8

\* 1 or 2 adjacent dot defects considered as 1 defect.

## EXTRAORDINARY CIRCUMSTANCES

Possible cases which cannot be influenced either by customer or Hatteland Technology.

### Examples for extraordinary circumstances:

- Allocation from LCD-Supplier
- Outstanding high number of LCD-panels with bright dots but within LCD-suppliers Specification.
- Sharply increased demand by customer

### In such cases a mutual agreement is inevitable.

### Examples:

- Acceptance of bright dots in "non-critical" display areas.
- Acceptance of bright dots with defined color.

Last Revised April 2019

Link to online resource:

[https://www.hattelandtechnology.com/hubfs/pdf/misc/ind100351-1\\_pixeldefectpolicy.pdf](https://www.hattelandtechnology.com/hubfs/pdf/misc/ind100351-1_pixeldefectpolicy.pdf)

## Parts in Displays and Panel Computers, and how to recycle

Part	Where to dispose of parts	
TFT Panel	Electrical waste	Optically bonded units: the TFT Panel, Glass and frame is to be disposed of as Electrical waste. Do not separate.
Glass	Metal waste	
Frame	Metal waste	
Chassis	Metal waste	
Brackets	Metal waste	
Motherboard / Electronic Boards (PCB's)	Electrical waste	
Power supply	Electrical waste	
Cable Kit	Electrical waste	
Outerbox, sleeve and Kit box	Paper waste	
Paper sheets/User Manual	Paper waste	
Plastic bags	Plastic waste	
EPS Foam	Plastic waste	

Contact Hatteland Technology for specific part numbers: <https://www.hattelandtechnology.com/spareparts>

### Dismantling of Displays and Panel Computers into its recyclable parts

To be able to dispose of the unit in the correct manner, Hatteland Technology bases its requirements on *Commissioning Regulation (EU) 2019/2021*. For more instructions concerned to the dismantling procedure, please contact Hatteland Technology. Reference online: <https://www.hattelandtechnology.com/parts-and-recycling>



Step 1. Separate the electronics from any metal and glass that is easily separatable.  
If unit is optically bonded, do not separate TFT panel from glass and Metal frame (glass, TFT panel and Metal Frame is to be disposed of as if electronic waste if Optically Bonded).

Step 2. Sort the source materials and dispose of the electronics and metal/glass parts in the appropriate recycling/sorting station.

### Spare Parts for Panel Computers (none for Displays)

Parts that require scheduled checks and replacement:

Part	Applicable for
SSD	Panel Computers
BIOS Battery	Panel Computers
Air filter	Panel Computers

Contact Hatteland Technology for specific part numbers: <https://www.hattelandtechnology.com/spareparts>

### Service Parts for Displays and Panel Computers

Parts that needs to be replaced in case of failure:

Part	Applicable for
CPU	Panel Computers
RAM	Panel Computers
Power Supply	Displays and Panel Computers
SSD	Panel Computers
CPU FAN/Cooler	Panel Computers
System fans	Displays and Panel Computers
Video Controller	Displays

Contact Hatteland Technology for specific part numbers: <https://www.hattelandtechnology.com/spareparts>

Contact Hatteland Technology for availability of Firmware and Software updates: <https://www.hattelandtechnology.com/support/contact>

## General Notes:

- The unit is tested according to IEC 60945 4th (EN 60945:2002), 4.4, equipment category b) "protected from the weather (formerly class B)".
- Use of brightness and push buttons may inhibit visibility of information at night.

## Manufacturing Note - 28 Jun 2021:

All Series 1 Generation 2 units manufactured from 1st of January 2021 to and including June 25th, 2021, had an incorrect polarity definition (silk print marking on terminal plate) that was reversed indicating originally "+ 24V DC -" instead of correct representation of "- 24V DC +".

Please note that all units have an internal fail-safe to protect reversed polarity connections and no damage would occur internally if connecting power, the result is that the unit will not be powered and show a black screen instead. As per rev1 of this user manual, released on 25th of June, 2021 all information and polarity definitions was correctly indicated.







# HATTELAND TECHNOLOGY

an EMBRON Company 