

Application

Most models of the T158 series microprocessor based thermostat/controller with digital display provide a combination of three-wire floating and/or on/off control. TA158 models are on/off control only. This series can control a variety of two-pipe and four-pipe fan coil units, air handling units, unitary equipment, for heating and cooling applications.

The microprocessor combines a proportional intergral control algorithm with adaptive logic. This provides control without the need for tuning or calibrating the control algorithm in the field.

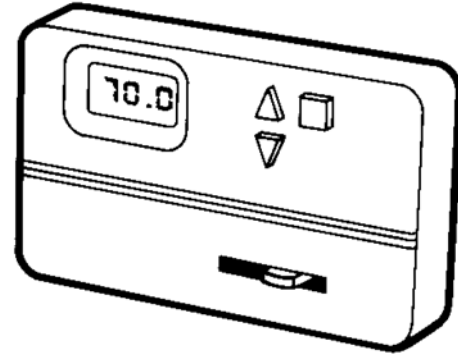

T158 Series

Features

- Heating and cooling outputs are individually configurable for three-wire floating or on/off control in the normally open or normally closed modes
- Line voltage continuous three-speed fan control
- Manual or automatic changeover
- Remote setback capability from a time clock or facility management system
- Fahrenheit or Celsius display capability
- Built-in purge cycle assists the controller to determine if the controlling agent is providing heating or cooling
- Microprocessor eliminates the necessity for tuning or calibration
- Set point may be calibrated to $\pm 5F$ degrees

CAUTION

- Do not use with DC powered motor circuits.
- Do not use on actuators with a stroke time of less than 1 minute or greater than 3 minutes.
- Do not use on actuators with position memory.

SPECIFICATIONS

Inputs

Power Input: 20 to 28 Vac, nominal 24 Vac.

Power Consumption: 25 mA maximum at 24 Vac.

Connections:

Power, Up to 14 AWG wire.

Control, Up to 14 AWG wire.

Outputs

Electrical:

Output Ratings, 10 VA at 24 Vac.

Operating Differential, 1F degree (0.6C degree).

Setpoint Adjustment Range, 50 to 90° F (10 to 32°C).

Changeover Deadband, 3F degrees (1.6C degrees).

Proportional Band, 2F degrees (1.1C degrees).

Mechanical:

Display Range, 32 to 99°F (0 to 37°C)

Material, Rigid vinyl.

Finish, Cool gray.

Environment

Temperature Limits:

Shipping & Storage, -30 to 130°F (-34 to 55°C).

Operating, 32 to 130°F (0 to 55°C).

Humidity: 95% Non-condensing.

Shipping Weight: 0.6 lbs (270 g).

Location: NEMA Type 1.

Agency Listings

CE: Compliant.

Performance

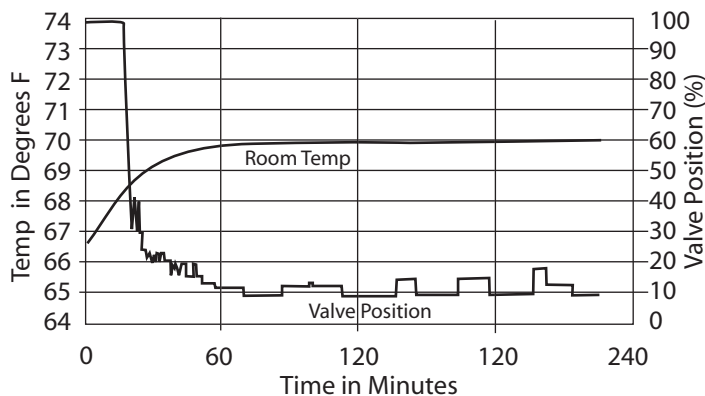

Figure-1 Typical T158 Performance Curve.

Table-1 Fan Switch Current Ratings (Amps).

Voltage	Inductive		Resistive Amps	Pilot Duty
	FLA	LRA		
24	N/A	N/A	N/A	24 VA
120	5.8	34.8	6.0	125 VA
240	2.9	17.4	5.0	125 VA
277	2.4	14.4	4.2	125 VA

Table-2 Model Chart.

Model	Outputs	Control Signal Options	Fan Control	Remote Sensor	Setback	System Switches
TA158-001	Dual	6	None	Yes	Yes	Off-Auto-Heat-Cool
TA158-002	Dual	6	Off-Hi-Med-Lo	Yes	Yes	Off-Auto-Heat-Cool
TB158-001	Dual	1, 2, 3, 4, 5, 6	None	Yes	Yes	Off-Auto-Heat-Cool
TB158-002	Dual	1, 2, 3, 4, 5, 6	Off-Hi-Med-Lo	Yes	Yes	Off-Auto-Heat-Cool
TB158-003	Single	5, 7	Off-Hi-Med-Lo	Yes	Yes	Off-Heat/Off-Cool
TB158-007	Single	5, 7	None	Yes	Yes	None
TB158-015	Single	5, 7	None	Yes	Yes	Off-Heat/Off-Cool
TB158-017	Dual	1, 2, 3, 4, 5, 6	Off/On	Yes	Yes	Off-Auto-Heat-Cool
TB158-018	Single	5, 7	Off/On	Yes	Yes	Off-Heat/Off-Cool

1. Three-wire floating single stage cooling and three-wire floating single stage heating.
2. Three-wire floating cooling and two stage on/off heating.
3. Single stage on/off cooling, on/off fan control and three-wire floating single stage heating.
4. On/off single stage cooling, on/off single stage heating and fan control.
5. Three-wire floating single stage cooling or single stage heating.
6. On/off single stage cooling, and on/off single stage heating.
7. On/off single stage cooling or on/off single stage heating.

Accessories

- 65345 4-3/4" x 4-3/4" adapter plate.
 65406 Remote/changeover sensor, 60" leads 10k Ω @ 77°F (25°C).

TYPICAL APPLICATIONS (wiring diagram)

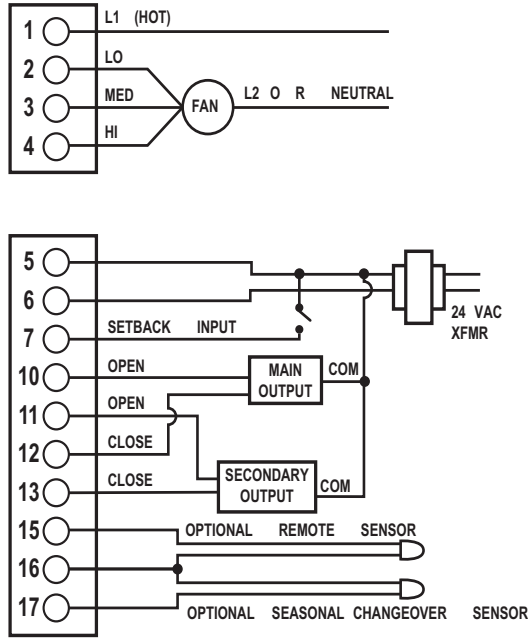

Figure-2 Typical Wiring For 3-Wire Floating Control.

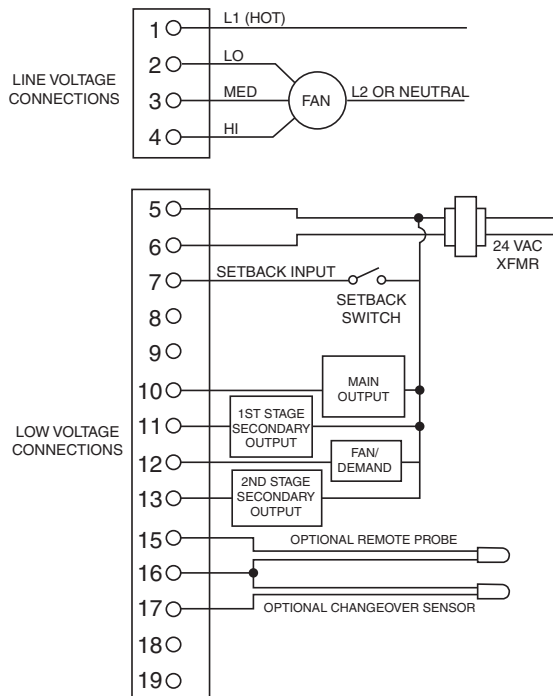

Figure-3 Typical Wiring For On/Off Control.

INSTALLATION

Inspection

Inspect the package for damage. If damaged, notify the appropriate carrier immediately. If undamaged, open the package and inspect the device for obvious damage. Return damaged products.

Requirements

- Tools (not provided)
 - Screwdriver
 - Digital multimeter
- Training: Installer must be a qualified, experienced technician
- Other accessories as appropriate

Precautions

General

WARNING:

- Electrical shock hazard! Disconnect power before installation to prevent electrical shock or equipment damage.
- Make all connections in accordance with the electrical wiring diagram and in accordance with national and local electrical codes.

CAUTION:

- Avoid locations where excessive moisture, corrosive fumes, explosive vapors, or vibration are present.
- Avoid electrical noise interference. Do not install near large conductors, electrical machinery, or welding equipment.

Federal Communications Commission (FCC)

NOTE

This equipment has been tested and found to comply with the limits for a Class B digital device, pursuant to Part 15 of the FCC Rules. These limits are designed to provide reasonable protection against harmful interference in residential installations. This equipment generates, uses, and can radiate radio frequency energy and may cause harmful interference if not installed and used in accordance with the instructions. Even when instructions are followed, there is no guarantee that interference will not occur in a particular installation. If this equipment causes harmful interference to radio and television reception—which can be determined by turning the equipment off and on—the user is encouraged to try to correct the interference by one or more of the following measures:

- Reorient or relocate the receiving antenna.
- Increase the separation between the equipment and receiver.
- Connect the equipment to an outlet on a circuit different from that to which the receiver is connected.
- Consult the dealer or an experienced radio/television technician for help.

Canadian Department of Communications (DOC)

NOTE

This class B digital apparatus meets all requirements of the Canadian Interference-Causing Equipment Regulations.

Cet appareil numérique de la classe B respecte toutes les exigences du Règlement sur le matériel brouilleur du Canada.

European Standard EN 55022

WARNING:

- This is a class B (European Classification) product. In a domestic environment this product may cause radio interference in which case the user may be required to take adequate measures.

Mounting

T158

Mount the T158 series to a suitable surface. Standard holes are provided for mounting purposes. Refer to Figure-4 . Mount the thermostat five feet above the floor on an inside wall. Do not mount near a heat source (lamp or sunlight) or behind a door or furniture.

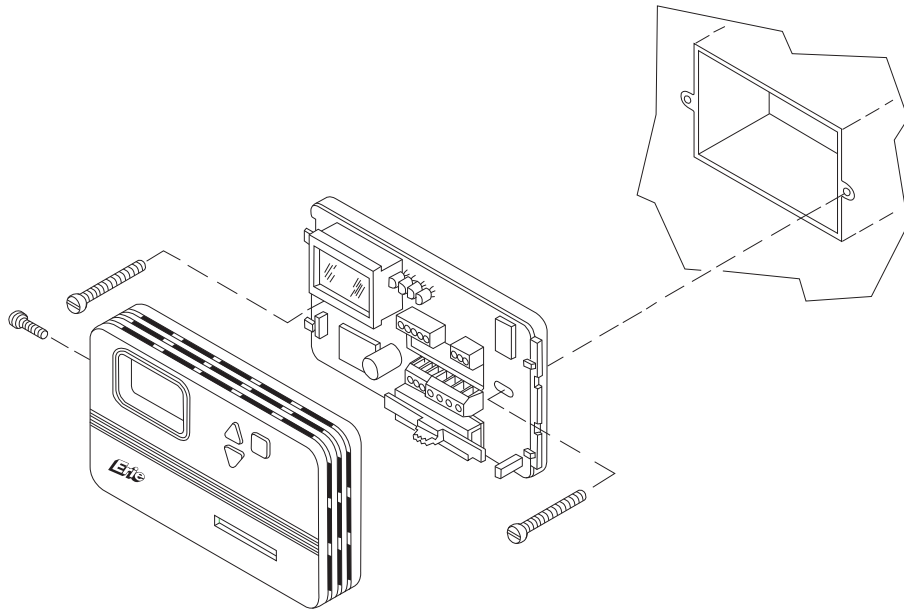

Figure-4 Mounting.

Seasonal Changeover Sensor

Mount the seasonal changeover sensor on to the main coil input or a pipe that will determine the fluid temperature of the coil. If a well is available use thermal grease for a faster temperature response. If strap on mounting, insulate the entire sensor and pipe before and after the sensor for a total of approximately six inches to decrease the affect of ambient temperature upon the sensor.

Remote Sensor

Install the sensor in a location that will only measure the temperature to be sensed without any external heating or cooling sources influencing the sensor. Avoid direct sunlight or dead air spaces. Be aware of the effect air movement and room stratification will have on the remote sensor.

WIRING

CONNECTIONS

- 15 REMOTE SENSOR
- 16 REMOTE SENSOR & CHANGEOVER SENSOR
- 17 CHANGEOVER SENSOR
- 10 MAIN OPEN
- 11 SECONDARY OPEN
- 12 MAIN CLOSE
- 13 SECONDARY CLOSE
- 5 24 VAC COMMON
- 6 24 VAC HOT
- 7 SETBACK INPUT
- 1 L1 (HOT)
- 2 FAN LOW/CONTINUOUS
- 3 FAN MED
- 4 FAN HIGH

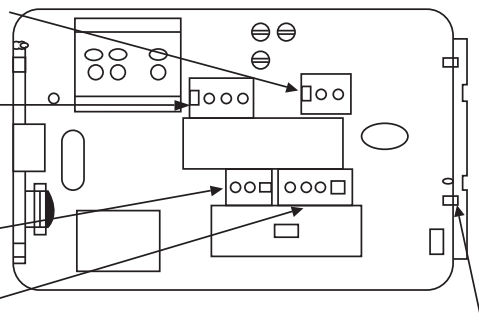

JP1: REMOVE TO ALLOW USE OF REMOTE PROBE

Figure-5 Terminal Definitions.

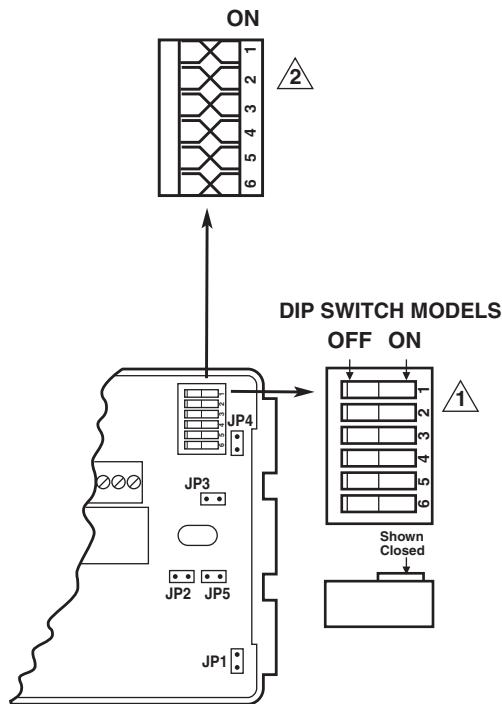

- 1 The dip switch housing is labeled "ON" with an arrow for slide switch "ON" direction.
- 2 Older styles will have cuttable jumpers uncut = On, cut = Off

TA158		
Cuttible Jumper/Dip Switch Designation	On/Uncut	Off/Cut
1	Secondary 1 ³ (term 11) NC	Secondary 1 ³ (term 11) NO
2	Main 1 ³ (term 10) NC	Main 1 ³ (term 10) NO
3	Fahrenheit Display	Celsius Display
4	Not Used	Operating Position
5	Not Used	Operating Position
6	Setback = 90F & 50F	Set back = 85F & 60F
TB158		
Cuttible Jumper/Dip Switch Designation	On/Uncut	Off/Cut
1	Secondary 1 ³ (term 11) NC	Secondary 1 ³ (term 11) NO
2	Main 1 ³ (term 10) NC	Main 1 ³ (term 10) NO
3	Fahrenheit Display	Celsius Display
4	Secondary 3-wire Floating (term 11 & 13)	Secondary 2 Stage On/Off (term 11 & 13)
5	Main 3-wire Floating (term 10 & 12)	Main 1 Stage On/Off 1 Demand On/Off (term 10 & 12)
6	Setback = 90F & 50F	Set back = 85F & 60F

a For On/Off control only, has no affect on 3-wire control. Affects the indicated Figure-6 Field Selectable Jumpers.

Sensor

In all applications run the sensor wire away from any electronic noise generating devices, such as motors, fluorescent lights, microwaves, or run in parallel to line voltage wiring. The maximum length of non-shielded sensor wire should not exceed 25 ft. (7.6 m).

Avoid electronic noise generating devices if possible. In an electronic noisy environment always use shielded wire. Connect the shielding to an earth ground. The maximum length of shielded sensor wire should not exceed 100 ft. (30.5 m).

Wiring Application

The T158 series thermostats are field configurable for a wide range of applications. Models built after January 2000 have configuration dip switches in the upper right corner of the circuit board. Models built before January 2000 were equipped with cuttable jumpers instead of dip switches for field configuration.

In addition to dip switches there are pin jumpers which are pairs of small pins. The pin jumper pairs are located on the right hand side of the T158 circuit board. The jumpered state means that both pins are covered by the black plastic jumper cap. In the un-jumpered state the jumper cap can be stored by placing the cap over either pin of the pin pair.

Field Configuration Options

NOTE

A single set point serves as the set point for both heating and cooling.

Cooling/Heating Output Logic

The factory default sets the main output to operate as the cooling output and the secondary output as the heating output. Follow these steps to change the factory default.

Dual Output Models: Connect a jumper wire from terminal 16 to terminal 17 to make the main output heating only and to disable the secondary output.

Single Output Models: Connect a jumper wire from terminal 16 to terminal 17 to make the main output heating.

Changeover Sensor

When no changeover sensor is installed on terminals 16 and 17 the main output controls are in cooling logic.

When a changeover sensor is installed the main output is cycled from heating to cooling or from cooling to heating depending upon the temperature measured by the changeover sensor strapped to the supply pipe or mounted in the return air duct. Refer to "Two Pipe Seasonal Changeover Sensor Operation" for more information.

CAUTION:

Keep all wiring at least 1-1/2 ft. away from any potential source of electrical interference or noise.

Remote Sensor

When using a remote sensor remove the jumper cap from pin pair JP1, located in the lower right corner of the circuit board. You can store the jumper cap on either pin of the JP1 jumper pair.

CAUTION:

Keep all wiring at least 1-1/2 ft. away from any potential source of electrical interference or noise.

Three-Wire Float and On/Off Logic

All TA158 models and model TB158-018 are capable of On/Off control only. All other TB158 models are capable of 3-wire float or on/off control.

Models that offer either 3-wire float or on/off control are shipped as 3-wire float units. To convert to on/off logic dip switches 4 and 5 must be oriented to the Off position. On older jumper models, cut jumpers 4 and 5 if on/off logic is required. Keep in mind that one output may be left as an on/off output while the other remains a 3-wire float output.

Demand Heat Logic

If equipped with the demand output, terminal 12, the T158 will automatically provide a 24 V output to power a fan relay any time there is a call or demand for heating or cooling. The maximum switched load is 10 VA @ 24 V. The secondary must be configured as an on/off output for the the demand feature to function properly.

Setback Logic

When in setback mode both the cooling and heating outputs operate as on/off outputs.

With dip switch/jumper 6 in the on state the T158 controls setback is set at 90°F cooling, 50°F heating. In the off state the setback is set at 85°F cooling, 60°F heating.

The setback mode is enabled when a contact closure occurs to terminal 7 on the T158. A time clock or building automation system must provide a dry contact, unpowered circuit to terminal 7.

During setback, in cooling mode, at 3 degrees above set point, the cooling device will be fully opened and will stay open until the temperature drops to the set point. In heating mode at 3 degrees below the set point the heating device will be fully opened until the temperature rises to the set point.

Setback Override: When in setback mode pressing any of three buttons, up arrow, down arrow, or system mode, will force the T158 into a 1 hour override. The thermostat will control the temperature for an hour at the non-setback mode set point.

APPLICATION NOTES

Digital Display Logic

System Switch Settings

Off: The heating and cooling functions are disabled, the set point can be adjusted and the fan is still operational.

Heat: Only heating is available. The cooling output will not be energized, no matter how warm the ambient temperature is.

Cool: Only cooling is available. The heating output will not be energized, no matter how cool the ambient temperature is.

Auto: The controller automatically determines what mode the controller should be in. When cooling is needed the controller will display "AUTO-COOL", when heating is needed "AUTO-HEAT", and when the controller is satisfied "AUTO" is displayed.

NOTE

Auto is not available on single output thermostats.

Fan Switch Settings

On: All outputs are active.

Off: Fan and system outputs are Off.

Set Point Adjustment

Operation

A touch of either arrow will display the set point. Continued pressure on either arrow will scroll the set point to new values. After three seconds with no pressure on either arrow, the selected set point becomes effective and the display of the room temperature resumes. The selected value is the control point for both heating and cooling.

Default

Units with a date code after 0599 (5th week of 1999) have a EEPROM installed and will maintain the last entered set point and operating mode when power is removed. When older units are powered down, the set point defaults to 70°F (21°C) and the mode defaults to "AUTO", these older units are dated codes 0499 and earlier.

Setback Mode

When a connection is made between terminals 5 and 7 (contact closure) the thermostat will be in setback mode. The cooling and heating set points are based on the configuration dip switch, position 6. While in the unoccupied mode, touching either the set point up arrow, down arrow or mode button will put the controller set point back to local control for a 1 hour period. When there is no connection between terminals 5 and 7 the set point is based on the value entered by the operator.

NOTE

To indicate setback mode operation the thermostat display is changed by suppressing the display of all mode information (only the room temperature is displayed).

Manual Changeover

The thermostat can change modes of operation only through the manual change of a mode button selection on the thermostat. The manual mode button prevents rapid cycling between modes of operation. These thermostats could also be described as Dual output: two output devices can be controlled. Heating and cooling thermostat, both heating and cooling devices are connected to the same thermostat; 4-pipe application: two valves serve the fan coil unit. SPDT thermostatic switching, no deadband.

Auto Changeover

Automatic changeover via the onboard thermistor or remote sensor, the thermostat changes modes of operation (AUTO-HEAT or AUTO-COOL) based on the differential between the set point and the controlled variable. This requires a deadband between the heating and cooling functions as part of the thermostat design. The deadband prevents rapid cycling between modes of operation. These thermostats could also be described as dual output: two output devices can be controlled. Heating and cooling thermostat, both heating and cooling devices are connected to the same thermostat; 4-pipe application: two valves serve the fan coil unit. Thermostatic switching is SPDT with no deadband.

When the ambient temperature reaches 3F degrees beyond a satisfied set point the mode changes to either "AUTO-HEAT" or "AUTO-COOL" with the same set point, see Figure-7.

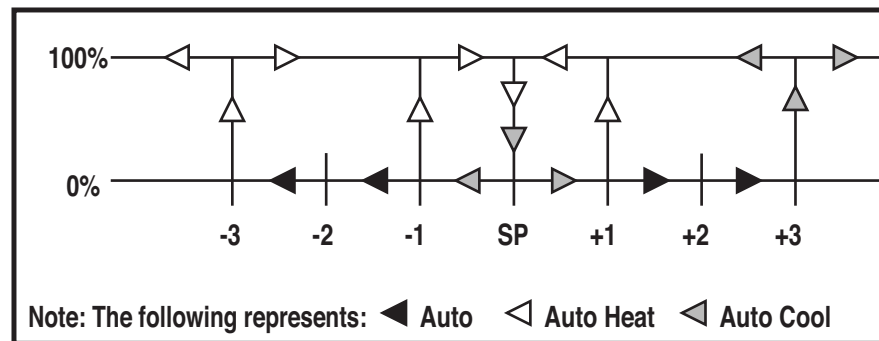

Figure-7 On/Off Control.

Upon initial startup (with no seasonal changeover sensor installed) the controller is in the "AUTO" mode. The controller determines automatically if it should be in the "AUTO-HEAT" or "AUTO-COOL" mode, based on the set point and ambient temperature. If the ambient temperature is below the set point on initial startup the unit will change to the "AUTO-HEAT" mode. During normal operation, after startup, when the ambient temperature reaches the set point, or above by up to 3F degrees, the unit will be in the "AUTO" mode. Once the ambient temperature reaches more than 3F degrees above the satisfied set point the unit changes to the "AUTO-COOL" mode. Since the ambient temperature is 3F degrees past the set point, the output goes to 100%. The unit remains in the "AUTO-COOL" mode until the ambient temperature again reaches the set point. If the ambient temperature drops below the set point the mode changes to the "AUTO" mode. If the ambient temperature reaches 3F degrees below the set point the mode changes to "AUTO-HEAT".

Cover Removal

The T158 cover snaps in to place at the display end and can be retained by a screw. With a T158 in hand, use a small flat blade screw driver in the cover ventilation slots closest to the base at the retaining screw end. Simultaneously push on the plastic retaining clip, which is visible in the slot, and pry up gently on the cover to free the cover from the base clips. It will be necessary to do this at both retaining clips. With a T158 mounted to a wall there may not be any space for the screw driver approach above. In that case, firmly grip the thermostat cover and push it to the left until the left end of the cover is free of the base clips.

Output Measurements

Always have a load connected when measuring the output signals with a voltmeter. If a load is not connected, phantom voltages caused by the output triacs will be read even when the outputs are off. The phantom values will be in the range of 2 to 24 Vac will have no ability to power a load, and will be slowly decreased by the drain of the voltmeter. The voltage read when the outputs are actually off and the decrease rate depends upon the quality of the meter used for the readings.

Output Signals

With a load connected, the 24 V 3-wire floating output signals can be measured from either the open (terminals 10 and 11) to common (terminal 5) or close (terminal 12 and 13) to common (terminal 5) terminals. When reading 24 Vac the algorithm is driving the output being measured. When the algorithm is satisfied, the voltage is removed from the outputs. With the output value at 0 Vac, either the algorithm is satisfied, or the outputs are at 100%

closed or 100% open. If the connected load is a TAC "T" series (3-wire floating control) modulating valve actuator (or similar), a reading of 14 to 17 Vac will also be noted on some terminals when outputs are being driven. With 24 Vac present on either the open or close terminal of the thermostat, the inactive output terminal may read a voltage in the range of 14 to 17 Vac. Voltage on inactive terminals is leakage from the triac circuit. These values will drop quickly.

3-Wire Floating Control

Three-wire floating control is a time-based modulating control method that energizes or de-energizes a 24 Vac signal between either the open (terminals 10 and 11) and common, or the close (terminals 12 and 13) and common terminals. This signal is energized for a calculated period of time and then de-energized. Once the signal is removed the actuator stays at the specified position until another signal is sent to change it. The controller retains the last known position in memory, in % of valve stroke, and determines a new output position based on the difference between the ambient temperature and set point.

The duration of the voltage output to an actuator by an TAC three-wire floating controller changes with the differential between the set point and controlled variable. If the controlled variable is more than 1F degree from the set point, the output is pulsed in 6-second increments, representing 5% of the actuator stroke for a 2-minute actuator. If the controlled variable is within 1F degree of the set point, the output is pulsed in 1.2-second increments, representing 1% of the actuator stroke for a 2-minute actuator.

3-Wire Floating Operation

When the ambient temperature is at the set point, both the heating and cooling outputs will be de-energized. When the controller is in the "HEAT" or "AUTO-HEAT" mode and the ambient temperature is between the set point and 2F degrees below the set point the heating device will be modulated in increments between 0 to 100% open. When the ambient temperature is 2F degrees or greater the set point, the heating device will be at 100% open. When the controller is in the "COOL" or "AUTO-COOL" mode and the ambient temperature is between the set point and 2F degrees above the set point the cooling device will be modulated in increments, between 0 to 100% open. When the ambient temperature is 2F degrees or greater above the set point, the cooling device will be at 100% open. When placed in the "OFF" mode, before shutting down, the 3-wire floating algorithm will first drive closed any valve that is open.

On/Off Operation

At the set point both the heating and cooling outputs will be off. In the "COOL" or "AUTO-COOL" mode when the ambient temperature is 1F degree above the set point the cooling output is energized and remains energized until the set point is reached, see Figure-7. In the "HEAT" or "AUTO-HEAT" mode, the first stage of heat is energized when the ambient temperature is 1F degree below the set point and remains energized until the set point is reached. The second stage of heat is energized when the ambient temperature is 4F degrees below the set point or 3F degrees beyond where the first stage turned on. The second stage of heat turns off at 1F degree below the set point.

Start-up

Upon start-up when either the main or secondary outputs are configured for three-wire floating, the controller energizes the close outputs (terminals 12 and 13) for a 3-minute period. After the 3-minute period the PI algorithm begins normal control of the outputs. This 3-minute initiation period establishes the end of travel position in the controller's memory and will be refreshed (by driving the actuator into the end of travel position for 30 seconds to one minute) whenever the control algorithm causes the valve to stroke to the 0% open or 100% open position. If the controller has a single output (main) the logic automatically puts it into either the "HEAT" or "COOL" mode depending on the seasonal changeover valve. If the controller has dual outputs (main and secondary) the logic automatically puts it into either the "AUTO", "AUTO-HEAT" or "AUTO-COOL" mode depending on the ambient temperature and the set point. If all the outputs are configured for On/Off control the controller starts normal control within 30 seconds after power is applied.

CALIBRATION

The T158 uses a 10K thermistor sensor to measure temperature. As the air temperature changes, the resistance of the thermistor changes. The change in the resistance is feed into the processor and the processor adjusts the output.

Up to 5 degrees of offset can be added or subtracted.

This is a software re-calibration of the room temperature displayed by the thermostat as well temperature value (controlled variable) which is compared to the set point to determine the thermostat output.

1. Supply 24 Vac to the thermostat.
2. Press the mode button, scrolling the thermostat into the Off mode.
3. Push the up and down arrows at the same time, holding them in the depressed position.
4. In one second the display will show an offset value if an offset was previously entered. If there was no offset the display will read "0.0".
5. An offset can be set to either positive or negative.
 - a. To create a positive offset, release the down arrow while keeping the up arrow depressed, until the desired offset is displayed up to 5 degrees.
Example: If the thermistor senses 70°F with a 5 degree positive offset the thermostat will read 75°F.
 - b. To create a negative offset, release the up arrow while keeping the down arrow depressed, until the desired offset is displayed up to 5 degrees.
Example: If the thermistor senses 70°F with a 5 degree negative offset the thermostat will read 65°F.
6. When the correct offset value is displayed release both the up and down arrows.
7. After a two second delay the display will indicate the room temperature plus or minus the offset entered.

Wiring Notes

When no changeover sensor is used, the main output is associated with the cooling device and the secondary output with the heating device.

Connecting a wire between terminals 16 and 17 on a single output unit forces the unit into the heating mode.

By connecting a wire between terminals 16 and 17 on the dual output units, the main output is associated with the heating device and the secondary output is disabled.

If terminals 16 and 17 are either shorted or have no sensor connected to them the controller only polls those connections during startup. If there is a sensor connected the controller polls its value every second along with the ambient temperature value.

When the unit is powered down the controller's set point defaults to 70°F (21°C) and the last entered set point is erased.

THEORY OF OPERATION

Control Algorithm

The PI control algorithm has a 2F degree proportional band. The proportional band is the amount of change required by the ambient temperature for the output to go from fully closed to 100% open. For example, in the heat mode, with a 70°F set point and an ambient temperature of 70° the output is 0%. At 69° the valve is at approximately 50%, and at 68° the output is 100%. The integral gain implies that the longer the error between the ambient and the set point temperatures exists, the more the output will change to eliminate the error. The integral portion of the algorithm eliminates the temperature offset.

Heat mode

When the ambient temperature is below the set point the output has positioned the valve somewhere between 0 and 100% open.

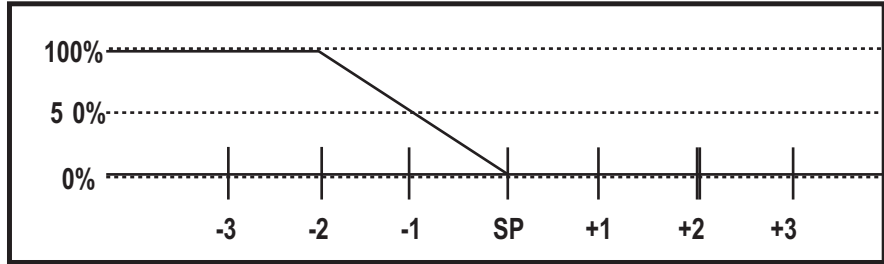

Figure-8 Heat Mode Graph.

Cool mode

When the ambient temperature is above the set point the output has positioned the valve somewhere between 0 and 100% open.

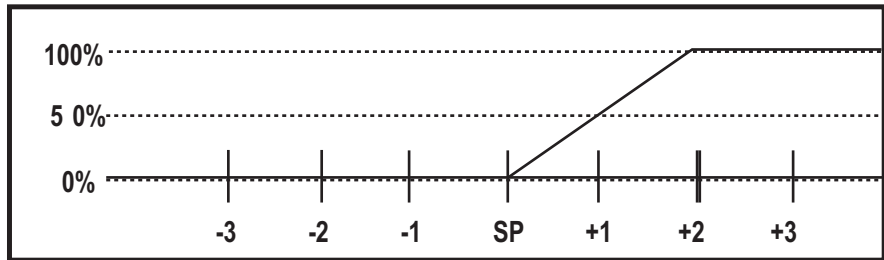

Figure-9 Cool Mode Graph.

Auto mode

Upon initial startup the controller is in the auto mode. The controller determines automatically if it should be in the "Auto-Heat" or "Auto-Cool" mode, based on the set point and the ambient temperature. When the ambient temperature is below the set point, the unit is in the "Auto-Heat" mode. When the ambient temperature reaches the set point or above by up to 3°F, the unit is in the "Auto" mode. Once the ambient temperature reaches 3°F past the satisfied set point the unit changes into the "Auto-Cool" mode. Since the ambient temperature is 3°F past the set point, the output goes to 100% open. The unit remains in the "Auto-Cool" mode until the ambient temperature reaches the set point. If the ambient temperature drops below the set point the modes changes into the "Auto" mode. When the ambient temperature reaches 3°F below the set point the mode changes to the "Auto-Heat" mode.

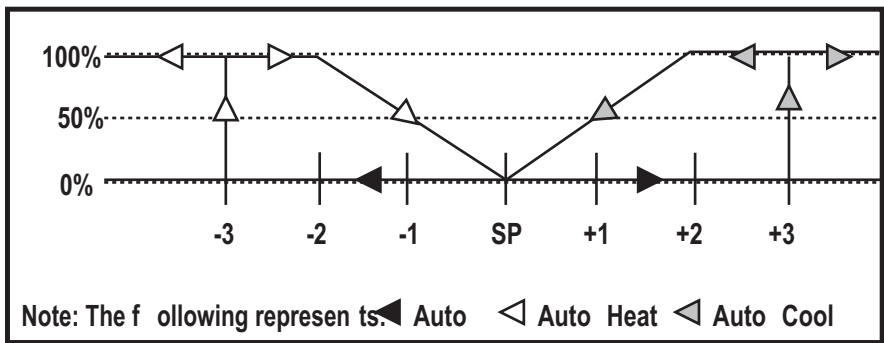

Figure-10 Auto Mode Graph.

Seasonal Changeover With the 65406 Sensor

The seasonal changeover logic will compare the sensed temperature at the pipe sensor with the actual ambient, room temperature as measured by the onboard thermistor in the thermostat.

During initial startup the thermostat determines the resistance value wired across terminals 16 and 17.

Resistance Below 350 Ohms

When a jumper wire is across terminals 16 and 17 the thermostat is locked into a heating only logic. Both the single or dual output thermostats will be configured as single output heating only thermostats. The heating output will be the main and only output. The processor will not be polled and will not check the status of the changeover terminals.

Resistance Over 350,000 Ohms

When neither a jumper wire or a 65406 thermistor is installed across terminals 16 and 17. The heating and/or cooling outputs will work normally. The main output is for cooling and the secondary output is for heating. The processor will not be polled and will not check the status of the changeover terminals.

Resistance Between 350 Ohms and 350,000 Ohms

When a 65406 thermistor is installed across terminals 16 and 17 of the thermostat. The processor will poll the resistance once every second and will then authorize the main output to control in either heating or cooling depending on the continuously changing value of the resistance.

2 Pipe Seasonal Changeover Sensor

The seasonal changeover function is most commonly used on a thermostat factory configured for 2-pipe operation. These are single output thermostats that do not have the "auto changeover" function.

Ambiguous State / Neither Heating or Cooling Logic

If the controller senses that the seasonal changeover temperature is within $\pm 15F$ degrees of the ambient temperature, the mode cannot be determined. The word "AUTO" is displayed to indicate the ambiguous state with no demand for either heating or cooling. The words "AUTO HEAT" or "AUTO COOL" are displayed to indicate the ambiguous state with a demand for heating or cooling based on the differential between the ambient temperature and the set point. With a demand for heating or cooling, the connected valve is driven open and a 3-minute timer for purge cycle sensing is started. On three-wire floating controllers, the controller operation is limited to two position control, 100% open or 100% closed.

To determine if heating or cooling is available the controller will start a three minute purge cycle. After purging for three minutes the controller again checks the seasonal changeover temperature for the ambiguous state. If the mode is no longer ambiguous the controller resumes normal operation (with as much as a three minute delay). If the sensor is still in an ambiguous state the controller does the following:

1. Continues to hold the valve open.
2. Checks if the seasonal changeover temperature is less than 60°F or greater than 80°F. If the temperature is less than 60°F (cooling mode) or greater than 80°F (heating mode) the controller is declared to no longer be in an ambiguous state and starts to control appropriately.
3. If the temperature is between 60 and 80°F the controller is still viewed as being in an ambiguous state and the purge continues with testing every three minutes until a non-ambiguous state occurs, $\pm 15F$ degrees criteria or 60/80°F criteria.
4. Once a non-ambiguous state is detected the controller waits for 1 hour before checking and allowing another purge cycle to occur. During this hour changes from heating to cooling and back are possible by pipe sensor changes of more than $\pm 15F$ degrees from the ambient.

Summer / Cooling Logic

When the pipe temperature is sensed to be 15F degrees below room temperature the thermostat will control in the cooling mode. The main output will be controlled via cooling logic, which means a rise in temperature above the thermostat set point will drive a valve open.

Winter / Heating Logic

When the pipe temperature is sensed to be 15F degrees above room temperature the thermostat will control in the heating mode. The main output will be controlled via heating logic. A fall in temperature below the set point will drive a valve open.

MAINTENANCE

The T158 series requires no maintenance. Replace defective units.

Regular maintenance of the total system is recommended to assure sustained, optimum performance.

FIELD REPAIR

None. Replace any damaged or failed components with functional replacements.

DIMENSIONAL DATA

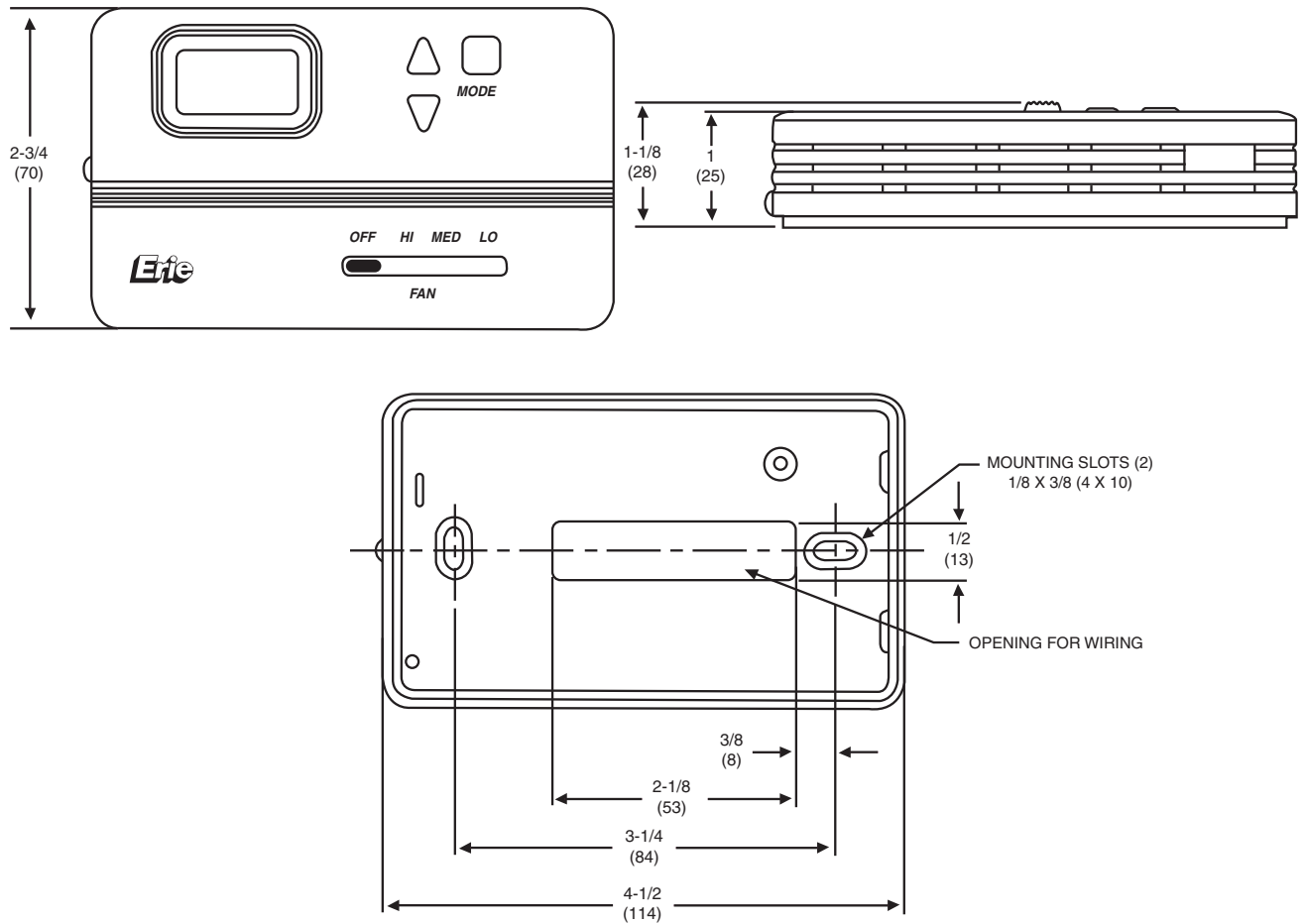
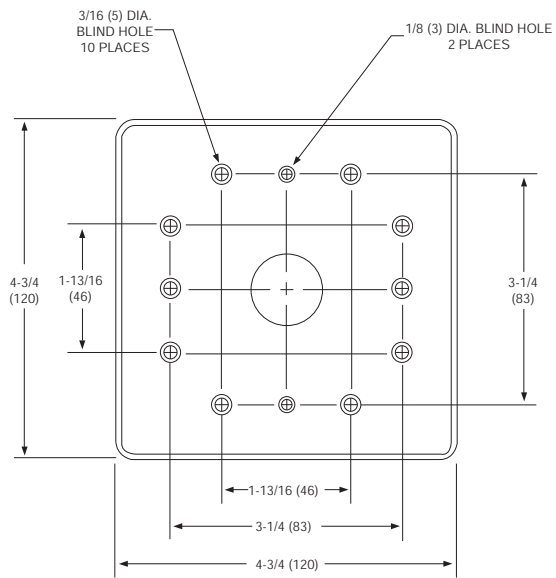

Figure-11 T158 Series.



WALL PLATE (BACK VIEW)

Figure-12 Adapter Plate.

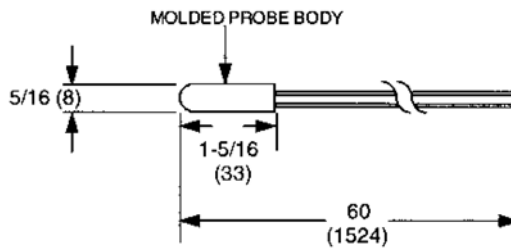

Figure-13 Remote Sensor.

On October 1st, 2009, TAC became the Buildings business of its parent company Schneider Electric. This document reflects the visual identity of Schneider Electric, however there remains references to TAC as a corporate brand in the body copy. As each document is updated, the body copy will be changed to reflect appropriate corporate brand changes.

Copyright 2010, Schneider Electric
 All brand names, trademarks and registered trademarks are the property of their respective owners. Information contained within this document is subject to change without notice.

Schneider Electric
 1354 Clifford Avenue
 P.O. Box 2940
 Loves Park, IL 61132-2940

www.schneider-electric.com/buildings

