

# Rosemount™ 396/396VP/397/398/398VP

pH/ORP Sensors

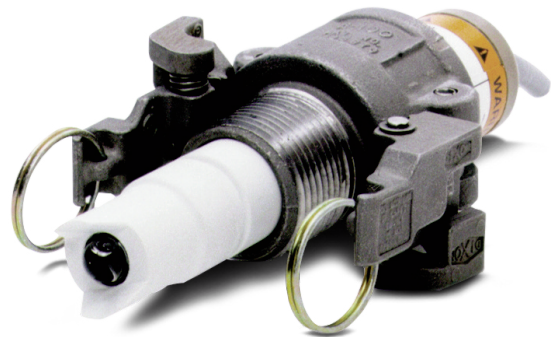



# Essential Instructions

## Read this page before proceeding!

Emerson designs, manufactures and tests its products to meet many national and international standards. Because these sensors are sophisticated technical products, you **MUST** properly install, use, and maintain them to ensure they continue to operate within their normal specifications. The following instructions **MUST** be adhered to and integrated into your safety program when installing, using, and maintaining Rosemount products. Failure to follow the proper instructions may cause any one of the following situations to occur: loss of life; personal injury; property damage; damage to this sensor; and warranty invalidation.

- Read all instructions prior to installing, operating, and servicing the product.
- If you do not understand any of the instructions, contact your Emerson representative for clarification.
- Follow all warnings, cautions, and instructions marked on and supplied with the product.
- Inform and educate your personnel in the proper installation, operation, and maintenance of the product.
- Install your equipment as specified in the Installation Instructions of the appropriate Reference Manual and per applicable local and national codes. Connect all products to the proper electrical and pressure sources.
- To ensure proper performance, use qualified personnel to install, operate, update, program, and maintain the product.
- When replacement parts are required, ensure that qualified people use replacement parts specified by Emerson. Unauthorized parts and procedures can affect the product's performance, place the safe operation of your process at risk, and **VOID YOUR WARRANTY**. Third-party substitutions may result in fire, electrical hazards, or improper operation.
- Ensure that all equipment doors are closed and protective covers are in place, except when maintenance is being performed by qualified persons, to prevent electrical shock and personal injury.

The information contained in this document is subject to change without notice.

### **DANGER**

#### Hazardous Area Installation

This sensor is not Intrinsically Safe, or Explosion Proof. Installations near flammable liquids or in hazardous area locations must be carefully evaluated by qualified on site safety personnel.

To secure and maintain an intrinsically safe installation, an appropriate transmitter/safety barrier/sensor combination must be used. The installation system must be in accordance with the governing approval agency (FM, CSA or BASEEFA/CENELEC) hazardous area classification requirements. Consult your transmitter instruction manual for details.

Proper installation, operation and servicing of this sensor in a Hazardous Area Installation is entirely the responsibility of the user.

---

### **CAUTION**

#### Sensor/Process Application Compatibility

The wetted sensor materials may not be compatible with process composition and operating conditions. Application compatibility is entirely the responsibility of the user.

---





# Contents

<b>Section 1: Description and Specifications</b>	
1.1 TUpH Features and Applications .....	1
1.2 Specifications .....	3
1.3 Product Certifications .....	4
1.4 Ordering Information.....	6
<b>Section 2: Installation</b>	
2.1 First Time Installation .....	9
2.2 Unpacking and Inspection .....	10
2.3 Mounting .....	10
2.4 Electrical Installation.....	17
<b>Section 3: Startup and Calibration</b>	
3.1 Sensor Preparation .....	33
3.2 Calibration Using Buffer Solution or Grab Sample.....	33
<b>Section 4: Maintenance</b>	
4.1 Electrode Cleaning.....	35
4.2 Automatic Temperature Compensator .....	36
<b>Section 5: Troubleshooting</b> .....	37
<b>Section 6: Accessories</b>	
6.1 Accessories .....	39
<b>EC Declaration of Conformity</b> .....	41
<b>Intrinsically Safe Sensor Installation Drawing - FM</b> .....	47



# Section 1: Description and Specifications

## 1.1 TUpH Features and Applications

The low maintenance and disposable Rosemount 396, 396VP, 397, 398, and 398VP TUpH sensors offer long life and high performance in measuring pH or ORP in aqueous solutions in pipelines, open tanks, or ponds.

These TUpH sensors feature a large area reference junction for maximum resistance to process coatings, generally found in dirty, high solid applications. In addition, the secondary helical reference pathway serves as added protection from poisoning ions. The simplified construction, designed with user convenience in mind, does not require electrolyte replenishment or any component replacement. All models feature a large glass bulb for increased resistance to the effects of aging for longer life.

### 1.1.1 Rosemount 396 and 396VP Sensor Features and Applications

Rosemount 396/396VP sensors are constructed of polypropylene and stainless steel and are completely sealed by EP (ethylene propylene) to eliminate process intrusion.

Sensors are specially designed for improved life in harsh, dirty applications such as lime slurry waste treatment and paper machine headbox and pigment/dye applications where large quantities of suspended solids are present. Installation is easily achieved through a wide variety of mounting configurations.



### 1.1.2 Rosemount 397 Sensor Features and Applications

The Rosemount 397 is housed in a highly chemical resistant polypropylene body and completely sealed with EP to eliminate process intrusion. The Rosemount 397 body is specifically designed for use with the Quik-Loc Kit which consists of an adapter and coupler. The PEEK (poly etheretherke tone) adapter enables the Rosemount 397 sensor to fit into a 1 in. MNPT Dixon coupler for quick and easy removal without sensor cable twisting. The 316 stainless steel Dixon coupler is sealed with EP and features locking arms. The Quik-Loc Kit is not recommended for use in processes with hazardous, corrosive, or strong oxidizing chemicals due to a risk of spray and bodily hazards.

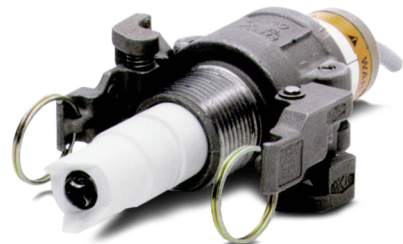

### 1.1.2 Rosemount 398 and 398VP Sensor Features and Applications

The chemical-resistant construction of Tefzel, titanium, and the TUpH reference junction make the Rosemount 398 and 398VP the ideal sensors for measuring pH in harsh process liquids. Use these sensors to measure pH in sour water strippers, in pulp bleaching towers that use chlorine dioxide, and in process streams containing a variety of organic solvents.

Rosemount 398 and 398VP sensors use the highest quality materials to provide superior chemical resistance. The sensors are housed in a titanium tube and features an optional 1 inch MNPT process connector for insertion, submersion, or flow-through applications. The molded Tefzel TUpH construction is offered with a choice of seals (Viton, EPDM, or Kalrez).

Figure 1-1: Cross Section Diagram of the TUpH Reference Technology

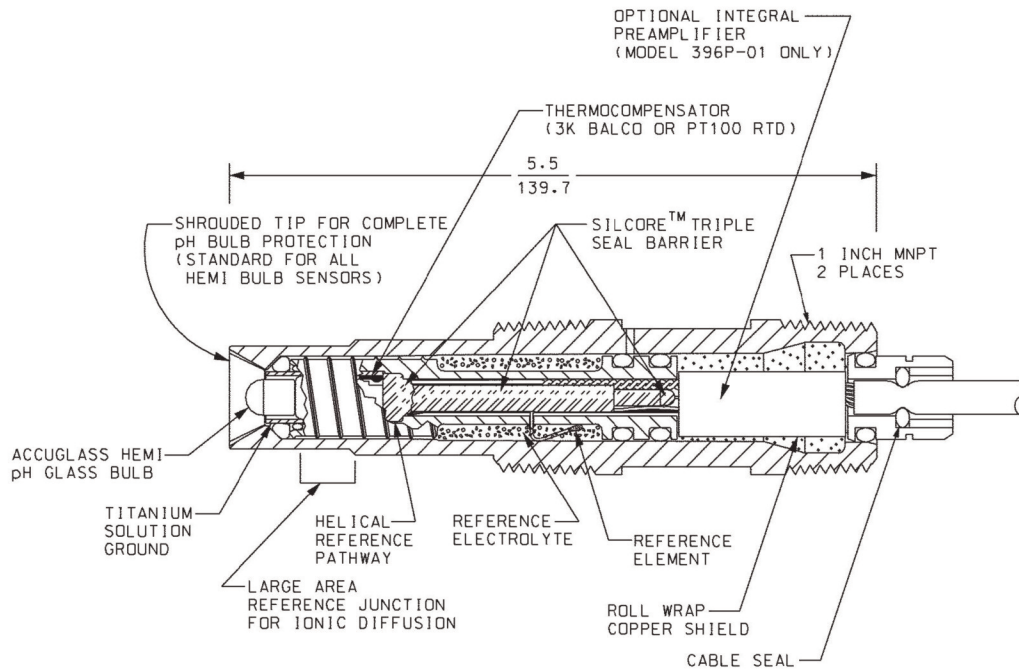

All TUpH sensors are designed with a large area reference junction, helical reference pathway, and an AccuGlass pH glass bulb. This sensor technology ensures superior performance while only requiring minimal maintenance.

## 1.2 Specifications

Table 1-1: Percent linearity over pH

	396, 396VP, 397, 398, 398VP	396, 396VP, 397, 398, 398VP
pH Range	GPHT Hemi	GPLR Hemi
0-2 pH	94%	93%
2-12 pH	99%	98%
12-13 pH	97%	95%
13-14 pH	92%	--

Table 1-2: Rosemount 396, 396VP, 397, 398 and 398VP Specifications

	Rosemount 396 396VP	Rosemount 398 398VP	Rosemount 397	Quik-loc Kit
Measured Ranges	0 to 14 pH	0 to 14 pH ORP: -1500 mV to 1500 mV	0 to 14 pH	—
Available pH ACCUGLASS Types	GPHT hemi bulb or GPLR flat bulb	GPHT hemi bulb or GPLR flat bulb	GPHT hemi bulb	—
Wetted Materials	316 SST, Polypropylene, EPDM, glass	Titanium, Tefzel, glass, choice of Kalrez, Viton, or EPDM (platinum: ORP only)	Polypropylene, EP, glass	316 SST, EP, PEEK
Process Connection	None, use 1 in. NPT process connector, PN 23166-00 or 23166-01 (sold separately)	None, use 1 in. NPT process connector, PN 23166-00 or 23166-01 (sold separately)	None, must use Quik- Lockit which includes 1 in. MNPT process connection	1-in. MNPT
Temperature Range	0-100 °C (32-212 °F)	0-100 °C (32-212 °F)	0-100 °C (32-212 °F)	
Pressure Range- Hemi bulb	100-1136 kPa abs (0-150 psig)	100-1825 kPa abs (0-250 psig)	100-790 kPa abs (0-100 psig)	—
Pressure Range- Flat bulb	100-790 kPa abs (0-100 psig)	100-790 kPa abs (0-100 psig)	—	—
Minimum Conductivity	75 µS/cm, nominal	75 µS/cm, nominal	75 µS/cm, nominal	
Preamplifier Options	Remote	Remote	Remote	
Weight/Shipping Weight	0.45 kg/0.9 kg (1 lb/2 lb)	0.45 kg/0.9 kg (1 lb/2 lb)	0.45 kg/0.9 kg (1 lb/2 lb)	0.45 kg/0.9 kg (1 lb/2 lb)

## 1.3 Product Certifications

Please see online certificates for further details.

Rosemount 396/396VP:

### IECEX

Sensors without preamp (pH and ORP) – Ex ia IIC T4 Ga (-20 °C ≤ Ta ≤ +60 °C)

Sensors with SMART preamp (pH only) – Ex ia IIC T4 Ga (-20 °C ≤ Ta ≤ +60 °C)



Sensors with standard preamp (396P only) – Ex ia IIC T4 Ga (-20 °C ≤ Ta ≤ +80 °C) or Ex ia IIC T5 Ga (-20 °C ≤ Ta ≤ +40 °C)

Per standards IEC60079-0 : 2011, IEC 60079-11 : 2011

### ATEX

Sensors without preamp (pH and ORP) –  II 1 G Ex ia IIC T4 Ga (-20 °C ≤ Ta ≤ +60 °C)

Sensors with SMART preamp (pH only) –  II 1 G Ex ia IIC T4 Ga (-20 °C ≤ Ta ≤ +60 °C)

Sensors with standard preamp (396P only) –  II 1 G Ex ia IIC T4 Ga (-20 °C ≤ Ta ≤ +80 °C) or  II 1 G Ex ia IIC T5 Ga (-20 °C ≤ Ta ≤ +40 °C)

Per standards EN 60079-0: 2012+A11:2013, EN 60079-11:2012

### FM

See online FM Certificate of Compliance for applicable sensor options:

Intrinsically Safe for use in Class I, II, and III, Division 1, Groups A, B, C, D, E, F, and G; Temperature Class T6 Ta = -20 °C to +60 °C

Intrinsically Safe for use in Class I, Zone 0, AEx ia IIC T6 Ta = -20 °C to +60 °C

Nonincendive for use in Class I, Division 2, Groups A, B, C, and D; Temperature Class T6 Ta = -20 °C to +60 °C

Suitable for use in Class II and III, Division 2, Groups E, F, and G; Temperature Class T6 Ta = -20 °C to +60 °C Hazardous (Classified) Locations

IS/I,II,III/1/ABCDEFG/T6 Ta = 60 °C - 1400332; Entity: I/0/AEx ia IIC/T6 Ta = 60 °C - 1400332; Entity: NI/I/2/ABCD/T6 Ta = 60 °C; S/II,III/2/EFG/T6 Ta = 60 °C

Per standards 3600:1998, 3610:2010, 3611:2004, 3810:2005

### CSA

See online CSA Certificate of Compliance for applicable sensor options:

Sensors with preamp – Intrinsically Safe:

Class I, Division 1, Groups ABCD; Class II, Division 1, Groups EFG; Class III; Class I, Division 2, Groups ABCD; Ambient temperature rating -20 °C to +60 °C; Ex ia IIC; T6

Sensors without preamp – Intrinsically Safe and Non-Incendive:

Class I, Division 1, Groups ABCD; Class II, Division 1, Groups EFG; Class III; Class I, Division 2, Groups ABCD; Ex ia IIC; T6; Ambient temperature rating -20 °C to +60 °C: (Simple Apparatus)

Per standards C22.2 No. 0-10, C22.2 No. 0.4-M2004, C22.2 No. 94-M1991, C22.2 No. 142 – M1987, C22.2 No 157 – M1992, CAN/CSA E60079-0:07, CAN/CSA E60079- 11:02, UL50 11th Ed, UL508 17th Ed, UL913 7th Ed,, UL 60079-0: 2005, UL 60079-11: 2002

Rosemount 397/398/398VP:

IECEX

Ex ia IIC T4 Ga (-20 °C ≤ Ta ≤ +60 °C)

Per standards IEC60079-0 : 2011, IEC 60079-11 : 2011

ATEX

⊕ II 1 G Ex ia IIC T4 Ga (-20 °C ≤ Ta ≤ +60 °C)

Per standards EN 60079-0: 2012+A11:2013, EN 60079-11:2012

FM

Intrinsically Safe for use in Class I, II, and III, Division 1, Groups A, B, C, D, E, F, and G; Temperature Class T6 Ta = -20 °C to +60 °C

Intrinsically Safe for use in Class I, Zone 0, AEx ia IIC T6 Ta = -20 °C to +60 °C

Nonincendive for use in Class I, Division 2, Groups A, B, C, and D; Temperature Class T6 Ta = -20 °C to +60 °C

Suitable for use in Class II and III, Division 2, Groups E, F, and G; Temperature Class T6 Ta = -20 °C to +60 °C Hazardous (Classified) Locations

IS/I,II,III/1/ABCDEFG/T6 Ta = 60 °C - 1400332; Entity; I/O/AEx ia IIC/T6 Ta = 60 °C - 1400332; Entity; NI/I/2/ABCD/T6 Ta = 60 °C; S/II,III/2/EFG/T6 Ta = 60 °C; Entity Parameters

Per standards 3600:1998, 3610:2010, 3611:2004, 3810:2005

CSA

Intrinsically Safe and Non-Incendive:

Class I, Division 1, Groups ABCD; Class II, Division 1, Groups EFG; Class III; Class I, Division 2, Groups ABCD; Ex ia IIC; T6; Ambient temperature rating -20°C to +60°C: (Simple Apparatus)

Per standards C22.2 No. 0-10, C22.2 No. 0.4-M2004, C22.2 No. 94-M1991, C22.2 No. 142 – M1987, C22.2 No 157 – M1992, CAN/CSA E60079-0:07, CAN/CSA E60079- 11:02, UL50 11th Ed, UL508 17th Ed, UL913 7th Ed, UL 60079-0: 2005, UL 60079-11: 2002

## 1.4 Ordering Information

The Rosemount 396 pH sensor features either a standard hemi bulb or flat glass electrode. The sensor is housed in a stainless steel body and must be used with a 1 inch MNPT threaded process connector (sold separately). The Rosemount 396 is not available with an integral preamplifier and comes standard with a 15 ft integral cable.

Table 1-3: Rosemount 396 ordering information

Model	Sensor type
396	pH/ORP Sensor
Transmitter/TC Compatibility	
50	3K TC (1)
54	Pt-100
Cable Option	
_	No Selection
62	Cable without BNC (2)
Electrode Option	
_	No Selection (3)
71	pH - GPHT Flat Glass
Typical Model Number: 396-54-62-71	

1. For use with legacy transmitter models 1181, 1050, and 1003.
2. For wiring to Rosemount 1056, 1066, 1057, 56, and 5081 transmitters.
3. No selection will configure the sensor with a standard hemi bulb glass electrode.

The Rosemount 396VP sensor features a Variopol cable connection for use with a mating Variopol interconnecting cable (sold separately).

Table 1-4: Rosemount 396VP ordering information

Model	Sensor type
396VP	pH/ORP Sensor
Temperature Compensation	
50	3K TC (1)
54	Pt-100
55	Pt-100 (for SMART Preamp) (2)
Electrode Option	
_	No Selection (3)
71	pH - GPHT Flat Glass
Preamplifier Option	
_	No Selection
70	SMART Preamplifier (4)
Typical Model Number: 396VP-55-71-70	

1. For use with legacy transmitter models 1181, 1050, 1003.
2. Must be selected with Option 70 for SMART Preamplifier.
3. No selection will configure the sensor with a standard hemi bulb glass electrode.
4. Must be selected with Option 55.



The Rosemount 398 sensor is housed in a titanium tube and made with a Tefzel reference junction. Sensors must be used with a 1 inch MNPT process connector (sold separately). These sensors come with a standard 15 ft. integral cable. A preamplifier must be used if the sensor is installed more than 15 ft. from the connected transmitter.

Table 1-5: Rosemount 398 ordering information

Model	Sensor type
398	pH/ORP Sensor
<b>Measuring Electrode Type</b>	
10	pH - GPHT Glass
12	ORP
13	pH - GPLR Flat Glass
<b>O-ring Material</b>	
30	EPDM
31	Viton
32	Kalrez
<b>Transmitter/TC Compatibility</b>	
50	3K TC (1)
54	Pt-100
<b>Cable Option</b>	
-	No Selection
62	Cable without BNC (2)
Typical Model Number: 398-10-30-54-62	

1. For use with legacy transmitter model 1181. Not available with option 62. If selected with ORP, sensor will not come with TC.
2. For use with Rosemount transmitter models 1056, 1066, 1057, 56, and 5081. Only available with option 54.

The Rosemount 398VP sensor features a Variopol cable connection for use with a mating Variopol interconnecting cable (sold separately).

Table 1-6: Rosemount 398VP ordering information

Model	Sensor type
398VP	pH/ORP Sensor
<b>Measuring Electrode Type</b>	
10	pH - GPHT Glass
12	ORP
13	pH - GPLR Flat Glass
<b>O-ring Material</b>	
30	EPDM
31	Viton
32	Kalrez
<b>Transmitter/TC Compatibility</b>	
50	3K TC (1)
54	Pt-100
Typical Model Number: 398VP-10-30-54	

1. For use with legacy transmitter model 1181. If selected with ORP, sensor will not come with TC.

The Rosemount 397 pH sensor is housed in a polypropylene body and is designed to be used with the Quik-Loc Kit (sold separately).

Table 1-7: Rosemount 397 ordering information

Model	Sensor type
397	pH/ORP Sensor
Preamplifier/Cable	
02	Without Integral Preamplifier, 15 ft (4.6 m) Cable
Measuring Electrode Type	
10	pH - GPHT Glass
12	ORP
Transmitter/TC Compatibility	
50	3K TC <sup>(1)</sup>
54	Pt-100
Other Options	
–	No Selection
62	Cable without BNC <sup>(2)</sup>
64	Tefzel Body Material
Typical Model Number: 397-02-10-54-62	

1. For use with legacy transmitter model 1181.
2. For use with Rosemount transmitter models 1056, 1066, 1057, 56, and 5081.

## Section 2: Installation

### 2.1 First Time Installation

For first time Rosemount 397 installations, using the following guide is recommended:

1. Quik-Loc Mounting (required for all first time installations)  
Choose one: PN 23757-00, Quik-Loc Kit: for use in 1 in. tees; insertion depth 1.4 in. (35 mm)
2. Remote Junction Boxes (optional, recommended for sensor to analyzer distances of more than 15 ft)  
Choose one: PN 23555-00 includes preamplifier
3. Extension cables (used with remote junction boxes)  
Choose one: PN 23646-01, 11 conductor, shielded, prepped  
PN 9200273, 11 conductor, shielded, unprepped

For first time Rosemount 396/396VP/398/398VP installations, using the following guide is recommended:

1. Process Connector Accessories (required for all first time installations with 1-inch process connection threads)  
Choose one: PN 23166-00, 316 SST, 1 in. x 1 in. NPT process connector, with EPDM O-ring  
PN 23166-01, Titanium, 1 in. x 1 in. NPT process connector, with EPDM O-ring  
PN 9510066, Nylon, 1 in. x 1 in. NPT process connector (submersion only)  
Choose one (optional process connector o-rings)  
PN 9550220, Kalrez o-ring, 2-214  
PN 9550099, Viton o-ring, 2-214
2. Variopol Cable (required for all first time installations) of Models 396VP and 398VP  
Choose one: PN 24281-00, 15 ft cable with mating VP connector  
PN 24281-06, 10 ft cable with mating VP connector
3. Mounting Accessories (optional)  
Choose one: PN 915240-03 PVC flow through tee, 3/4 in. NPT process connection  
PN 915240-04 PVC flow through tee, 1 in. NPT process connection  
PN 915240-05 PVC flow through tee, 1 1/2 in. NPT process connection  
PN 11275-01 Sensor handrail mounting assembly  
PN 2002011 1-1/2 in. CPVC Tee with 1 in. FNPT connection  
PN 24091-00 Low Flow Cell
4. Remote Junction Boxes (optional, recommended for sensor to analyzer distances of more than 15 ft)  
Choose one: PN 23555-00 includes preamplifier
5. Extension cables (used with remote junction boxes)  
Choose one: PN 23646-01, 11 conductor, shielded, prepped  
PN 9200273, 11 conductor, shielded, unprepped

## 2.2 Unpacking and Inspection

Inspect the outside of the carton for any damage. If damage is detected, contact the carrier immediately. Inspect the instrument and hardware. Make sure all the items in the packing list are present and in good condition. Notify the factory if any part is missing. If the sensor appears to be in satisfactory condition, proceed to Section 2.2, Mounting.

**Note:** Save the original packing cartons and materials as most carriers require proof of damage due to mishandling, etc. Also, if it is necessary to return the instrument to the factory, you must pack the instrument in the same manner as it was received. Refer to Section 6 for return instructions. If the sensor is to be stored, the vinyl boot should be filled with pH buffer solution and replaced on sensor tip until ready to use.

### WARNING

Glass electrode must be wetted at all times (in storage and in line) to maximize sensor life.

## 2.3 Mounting

Each sensor has been designed to be located in industrial process environments. Temperature and pressure limitations must not be exceeded at any time. A caution or warning label regarding this matter is attached to each sensor. For insertion, transfer the label as shown on label instructions. See Figure 2-2. For submersion applications, first note limits then remove and discard label.

**Note:** Before mounting the sensor, shake down the sensor to remove any air bubbles that may be present at the tip of the pH glass bulb. In most cases, the pH sensor can simply be installed as shipped and readings with an accuracy of  $\pm 0.6$  pH may be obtained. To obtain greater accuracy or to verify proper operation, the sensor must be calibrated as a loop with its compatible analyzer or transmitter.

### 2.3.1 Flow Through and Insertion Mounting for Rosemount 396, 396VP, 398, and 398VP Sensors.

These sensors can be used with a 1 inch MNPT process connector at the front of the sensor for mounting into a 1-1/2 inch tee or the process. See Figure 2-1 for installation configurations.

### 2.3.2 Submersion Mounting for Rosemount 396, 396VP, 398, and 398VP Sensors.

These sensors also have a 1 inch MNPT process connector available for use on the back of the sensor. Tapered pipe threads in plastic fittings tend to loosen after installation. It is therefore recommended that Teflon tape be used on the threads and that the tightness of the connection be checked frequently to assure that no loosening has occurred. To prevent rain water or condensation from running into the sensor, a weatherproof junction box is recommended (see Figure 2-4). The sensor cable must be run through a protective conduit for isolation from electrical interference or physical abuse from the process. The sensor should be installed within 80° of vertical, with the electrode facing down. The sensor's cable should not be run with power or control wiring.

## 2.3.2 Quik-Loc Mounting for Rosemount 397

The Quik-Loc mounting is used with the Rosemount 397 sensor only.

### WARNING

Once the Quik-Loc unit is installed the operator should wait for the process to cool to a safe temperature, use the pressure drain valve to relieve all process pressure and observe the pressure on the pressure gauge for proper removal of the sensor without spray or bodily injury. The Quik-Loc kit used with the Rosemount 397 sensor is not recommended for use with hazardous, corrosive, or strong oxidizing chemicals due to a risk of spray or bodily injury.

### WARNING

It is recommended that a thermometer, drain valve to relieve pressure and pressure gauge be inserted near the Quik-Loc assembly (see Figure 2-5).

Wrap the pipe threads of the Twin-Kam Kamloc coupler with Teflon tape before placing it into the process pipe. The coupler can be connected to any 1 in. process connection and must be mounted within 80° of vertical, with the electrode facing down. Once the coupler is in place, the adapter should be positioned onto the back end of the sensor. (See Figure 2-5) Remove the parafilm wrap from the two O-rings on the sensor, grease the O-rings with the lube provided, and feed the sensor cable through the adapter. Once the adapter is slipped over the sensor's back end, the retaining ring (which is included with every Rosemount 397 sensor) should be installed on the black, grooved, back end of the sensor body. The retaining ring secures the sensor into the adapter. The adapter/sensor assembly is now ready to be inserted into the coupler. With both arms of the coupler in the released position, insert the adapter/sensor assembly into the coupler.

**Note:** The adapter can not be inserted completely or properly unless both arms are in the fully released position (see Figure 2-5).

Once the adapter has been properly placed in the coupler, both arms should be positioned in the locked position. A Sur-Loc™ spring arm has been provided on one arm so that the arm cannot be opened until the spring is released.

**Note:** The sensor may obstruct flow through smaller pipes.

Once the arms of the coupler have been locked in position, use tamper-evident safety wire on the metal rings of the Twin-Kam arms to prevent unauthorized and/or untrained personnel from using the Quik-Loc unit.

### WARNING

It is the responsibility of each company using the Quik-Loc Kit/ 397 TUpH Sensor to train personnel of the injury risks associated with using a quick-release coupler that is placed in a hot or pressurized process.

The Quik-Loc unit should be used only within the pressure and temperature limits stated for the Rosemount 397 sensor in Section 1.2.

Figure 2-1: Recommended Flow Through and Insertion Installation for Rosemount 396, 396VP, 398, and 398VP Sensors

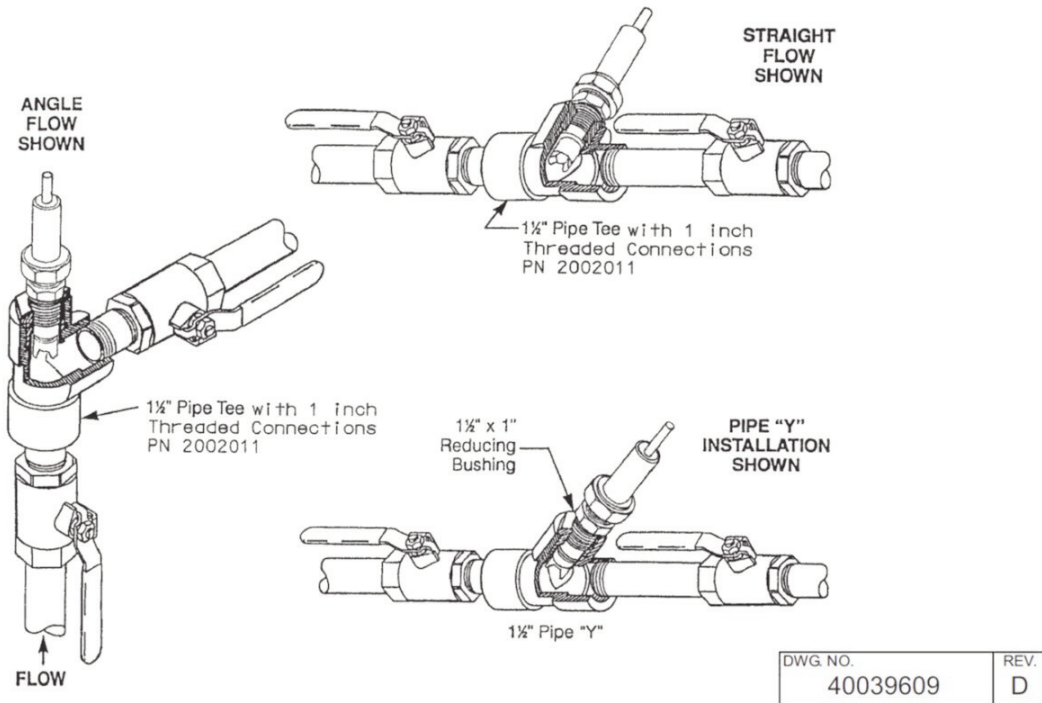

1-1/2 inch Pipe Tee (PN 2002011) with 1 inch threaded connections.

Figure 2-2: Recommended Flow-Through and Insertion Installation For Rosemount 397

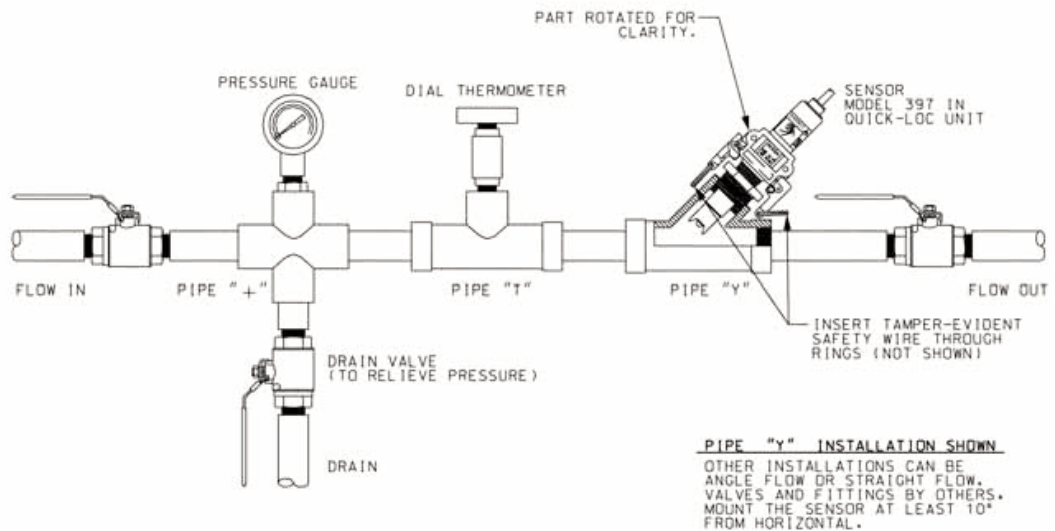
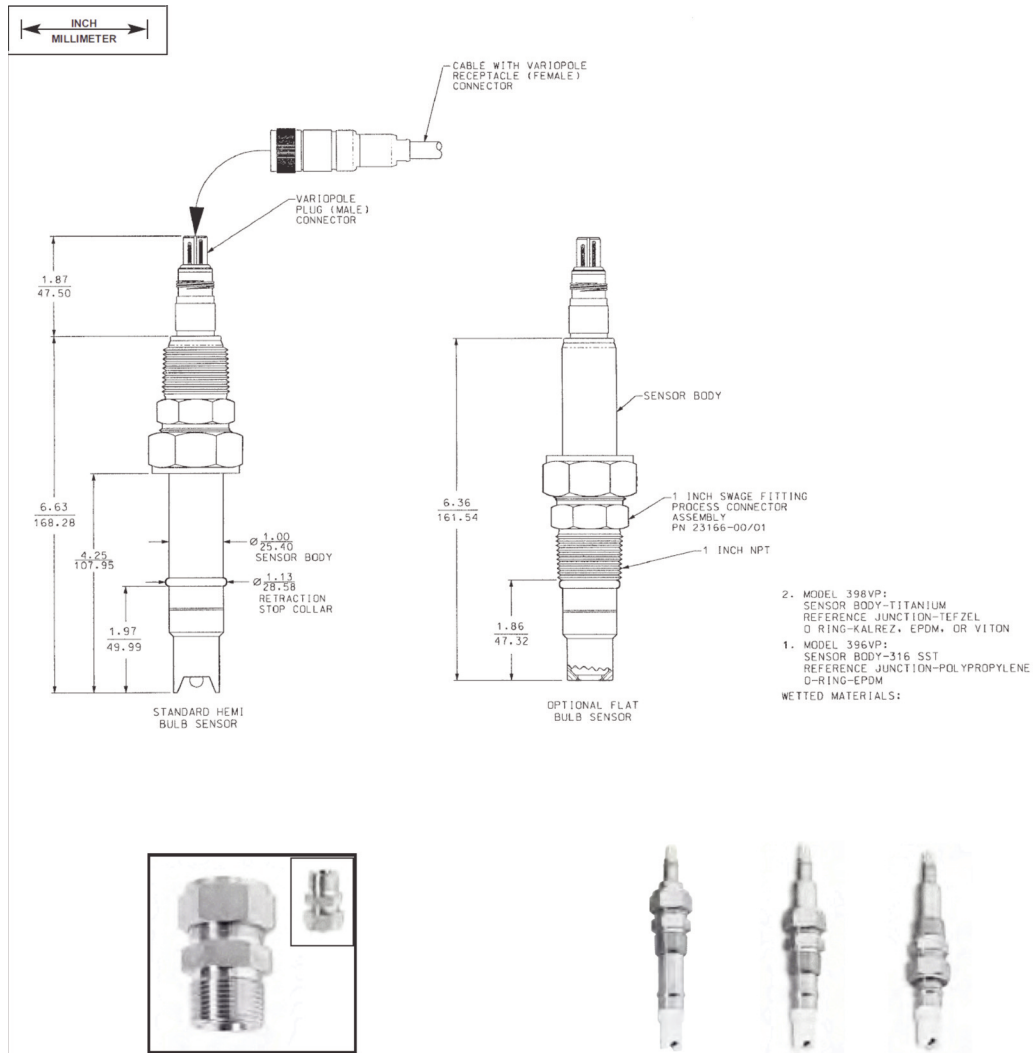



Figure 2-4: Rosemount 396VP and 398VP Sensor Dimensional Drawings (Shown with Process Connector)



Metal Process Connector PN 23166-xx (xx = 00 for 316 SST and xx = 01 for titanium) can be used for insertion or submersion mounting of Rosemount 396VP/398VP sensors in 1-inch fittings.

The metal process connector gives the sensor various insertions depths, depending on where the user locates the compression fitting. Also the threads can be switched to face the cable end of the sensor for connection to submersion pipes.





Figure 2-6: Dimensional Drawings For Rosemount 397 in the Quik-Loc Unit

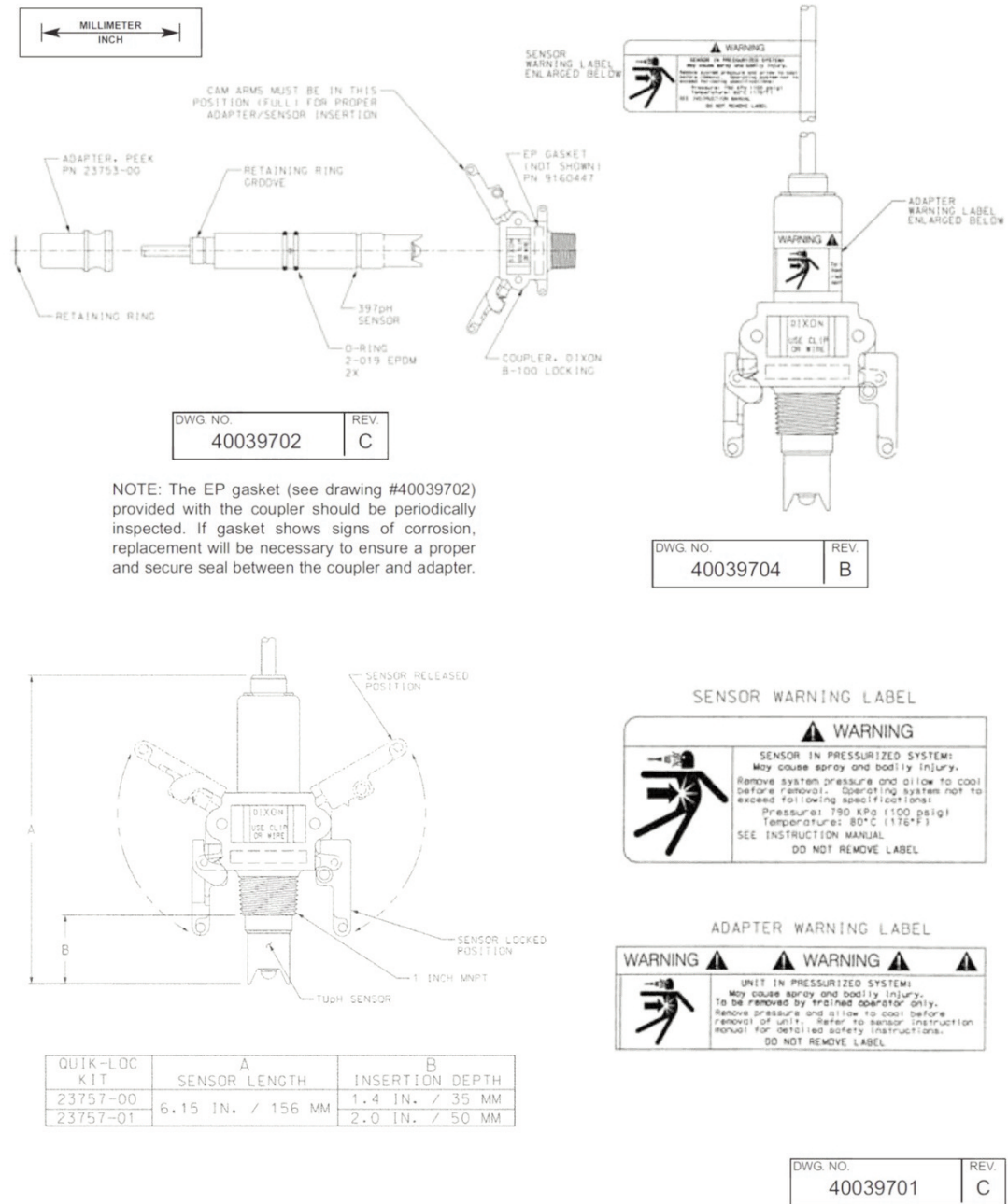

## 2.4 Electrical Installation

Rosemount 396, 396VP, 397, 398, and 398VP sensors are for use with a remote preamplifier. Each sensor comes with either a special 15 ft low noise coax cable or a Variopool (VP) connector, which is used with a mating Variopool cable. The cable should be handled carefully, and kept dry and free of corrosive chemicals at all times. Extreme care should be used to prevent the cable from being twisted, damaged or scraped by rough, sharp edges or surfaces.

For additional wiring information on this product, please refer to [Wiring Diagrams](#).

**⚠ DANGER**

DO NOT CONNECT SENSOR CABLE TO POWER LINES. SERIOUS INJURY MAY RESULT.

Note: Remove electrical tape or shrink sleeve from gray reference wire before connecting wire to terminal.

Figure 2-7: Wiring for Rosemount 396/397/398 to Rosemount 5081-P

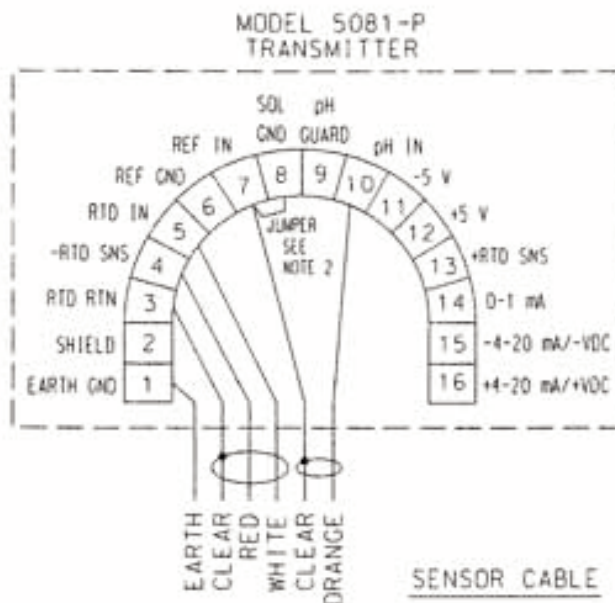

- NOTES:
1. JUMPER SUPPLIED BY CUSTOMER.
  2. ADDITIONAL CABLE PREPARATION REQUIRED FOR MODELS 389-02-54, 396-54, AND 397-02-10-54. SEE DRAWING NO. 40308131 FOR CABLE PREPARATION INSTRUCTIONS.

Model 389 -02-54\*, 389 -02-54-62, 396 -54\*, 396 -54-62, 397 -02-10-54\*, and 397 -02-10-54-62 Sensor Wiring to Model 5081-P

\* NEEDS ADDITIONAL CABLE PREPARATION.

Figure 2-8: Wiring for Rosemount 396-54, 397-54, and 398-54 (Pt-100 RTD). For Use With Junction Box (PN 23555-00) and Remote Preamplifier.

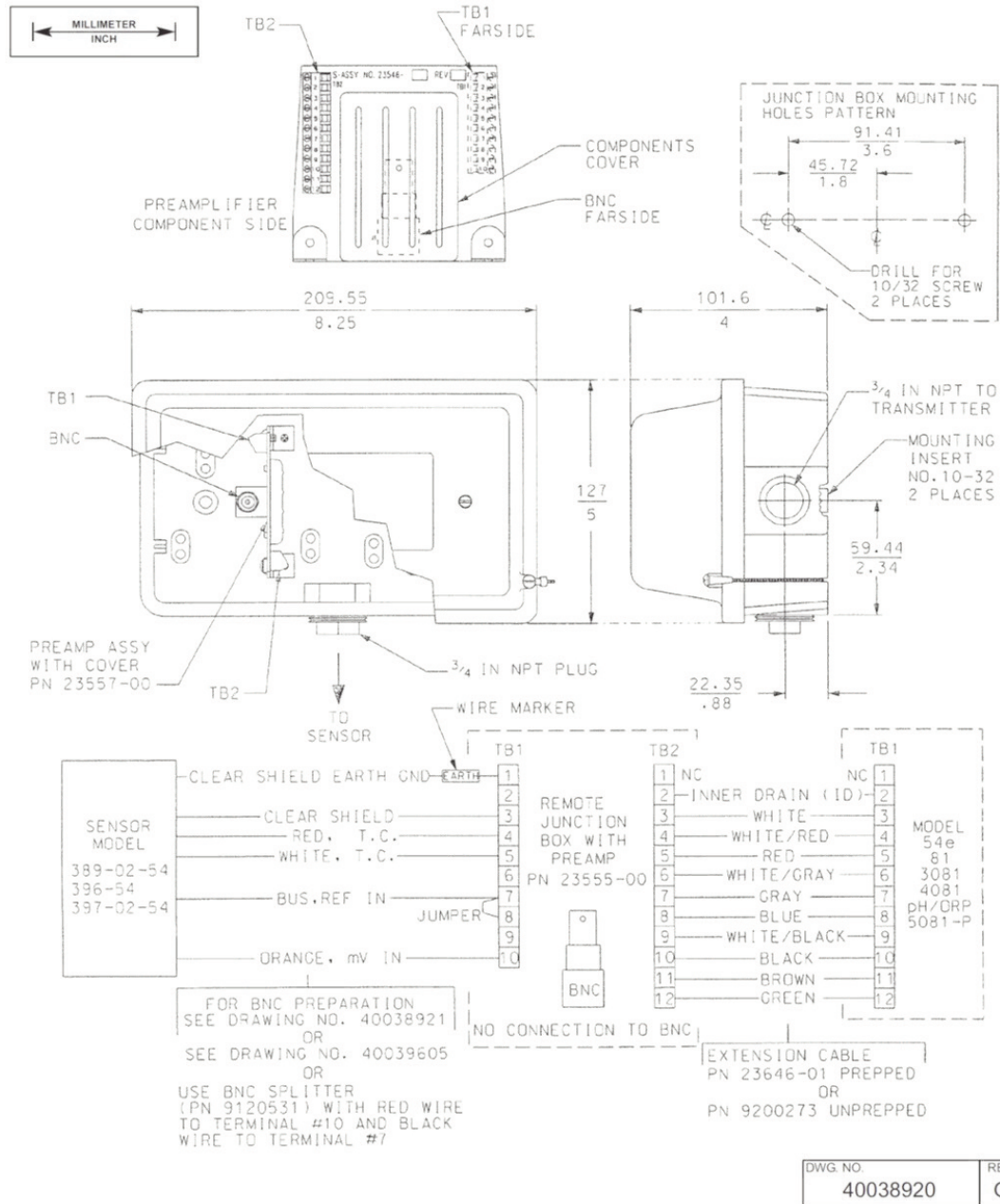
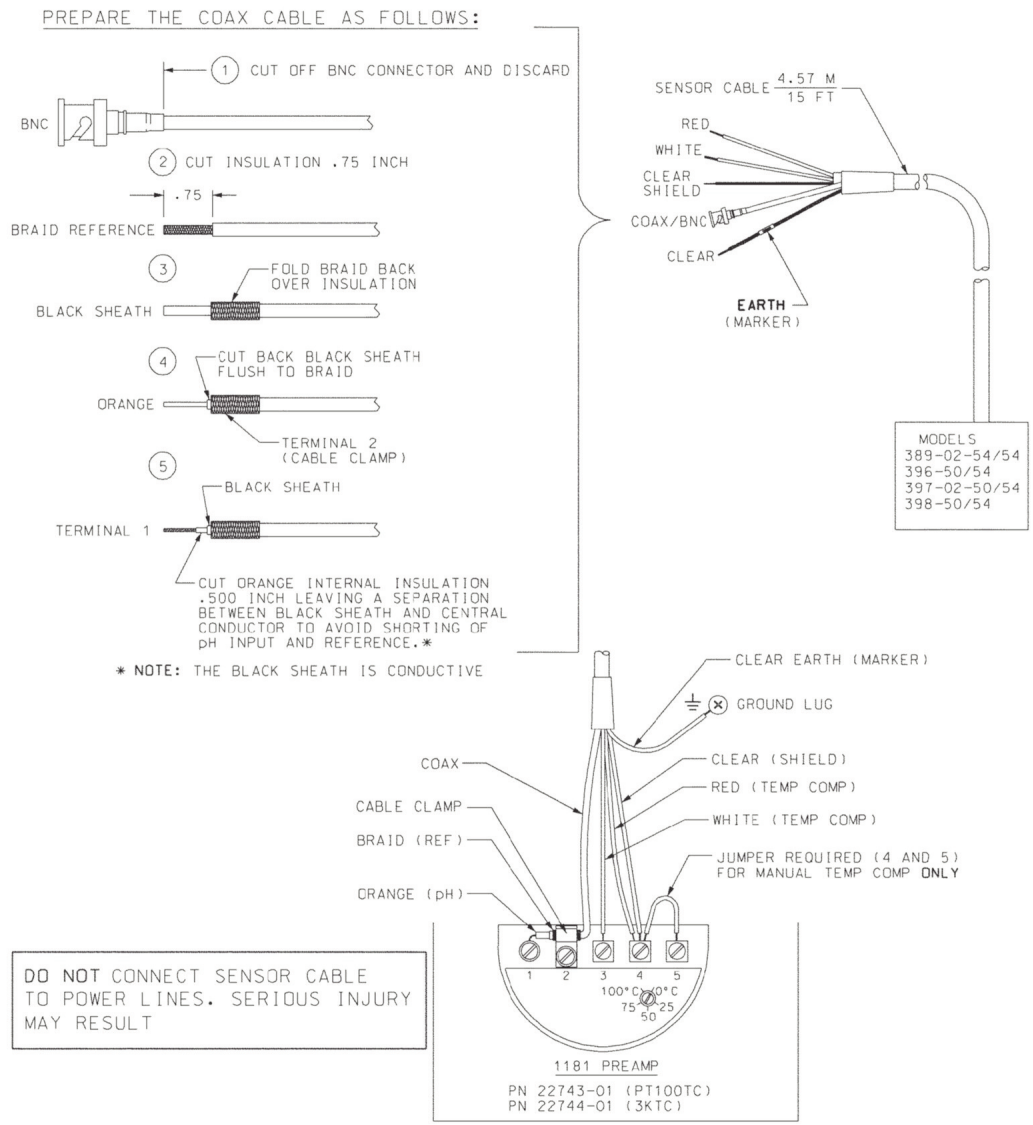

Figure 2-9: Wiring for Rosemount 396, 397, and 398. For Use With Model 1181 pH.



DWG NO.	REV.
40039607	D



Figure 2-10: Wiring for Rosemount 396-54 , 397-54, and 398-54. For Use With Rosemount 54, 54e, 81, 3081, 4081, and 5081.

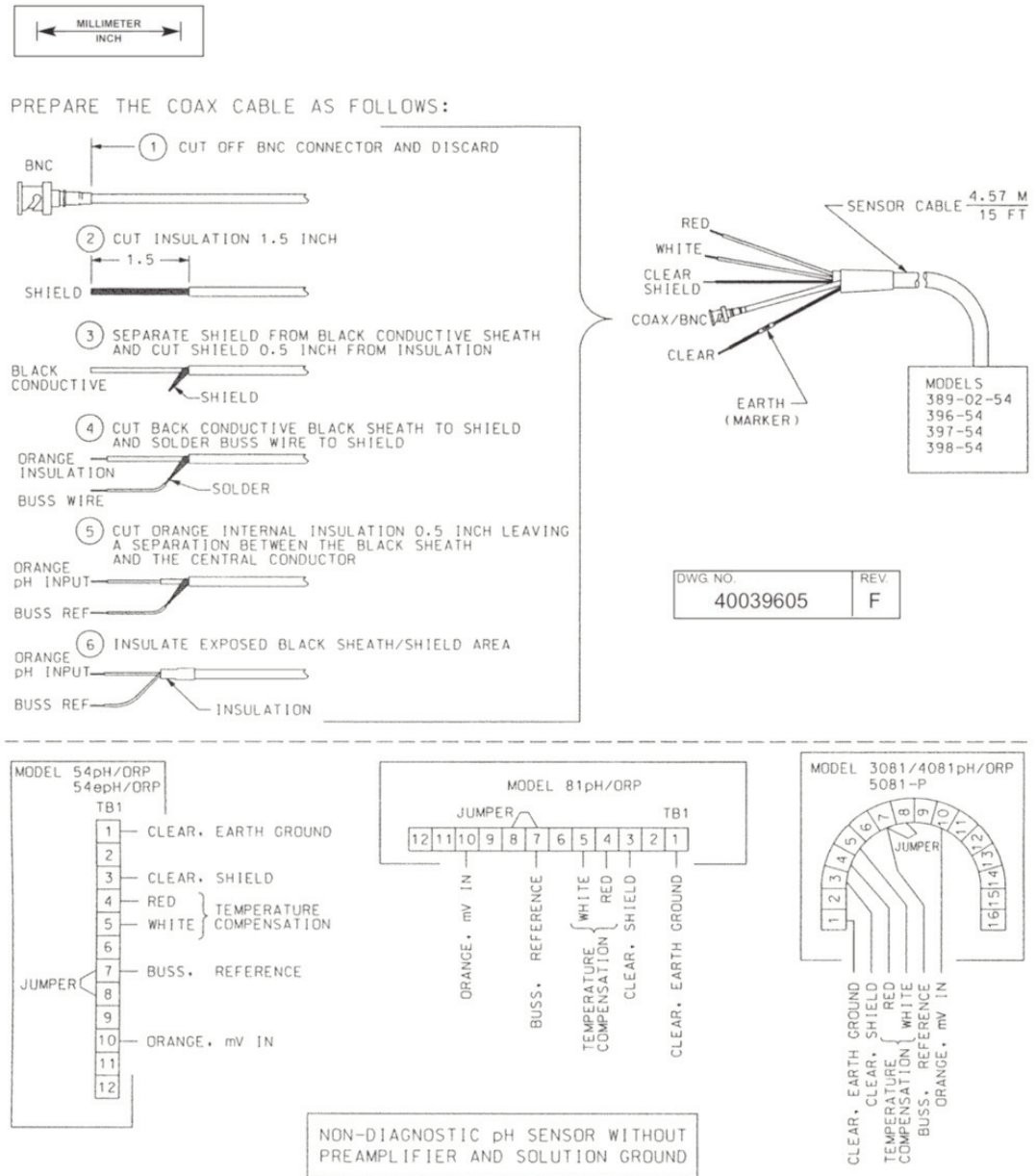

Figure 2-11: Wiring for Rosemount 396VP and 398VP to Rosemount 3081, 4081, and 5081 through a Remote Junction Box.

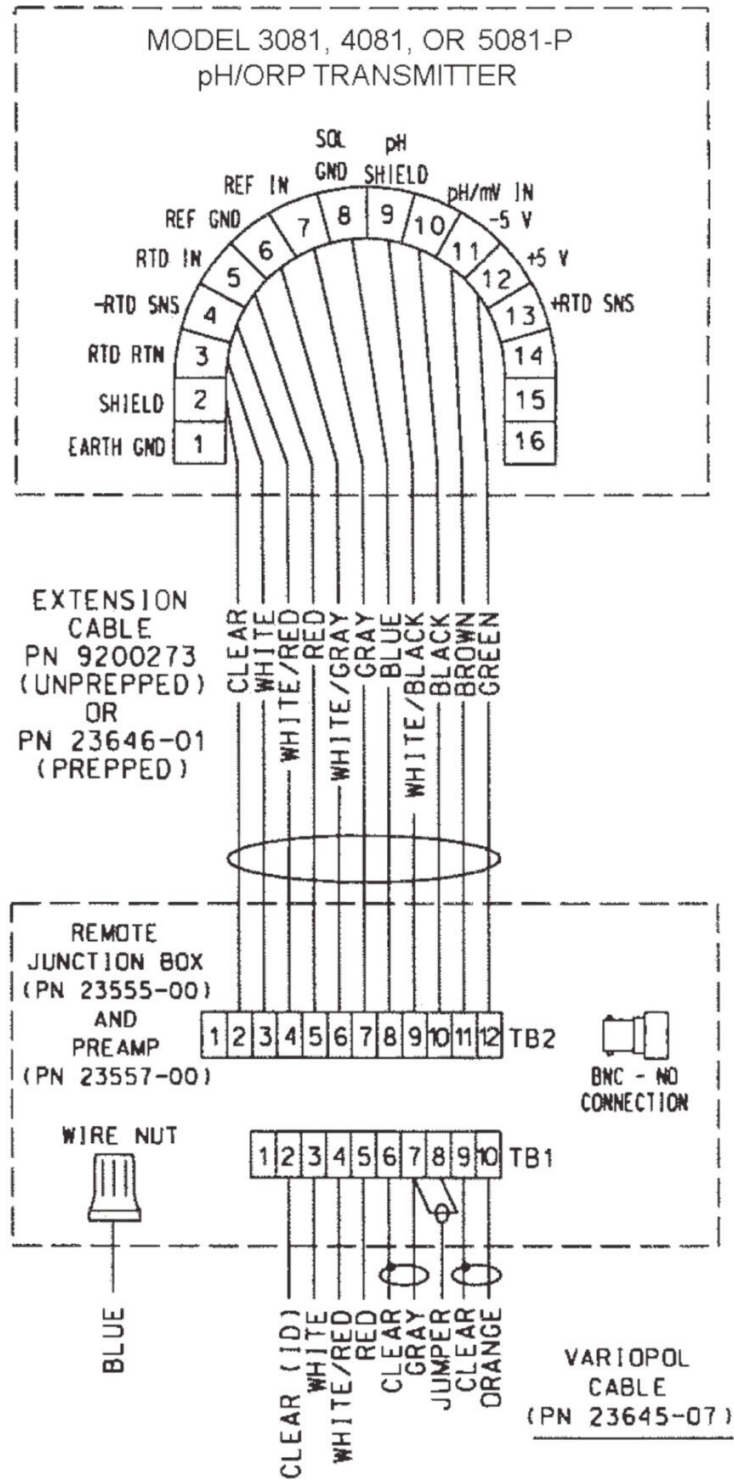

Figure 2-12: Rosemount 396-54-62-xx Wiring to Rosemount 1056/1057/56 Transmitters

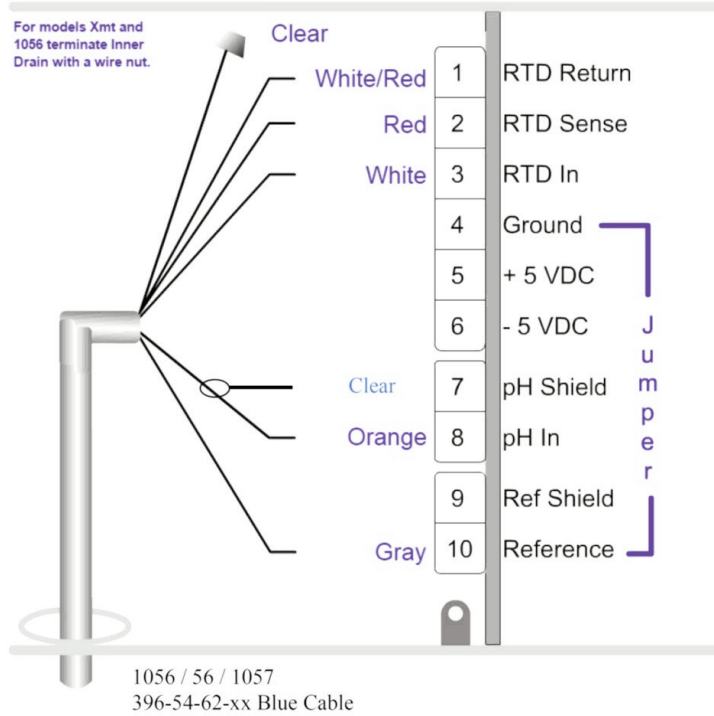

Figure 2-13: Rosemount 396-54-62-xx Wiring to Rosemount 1066 Transmitter

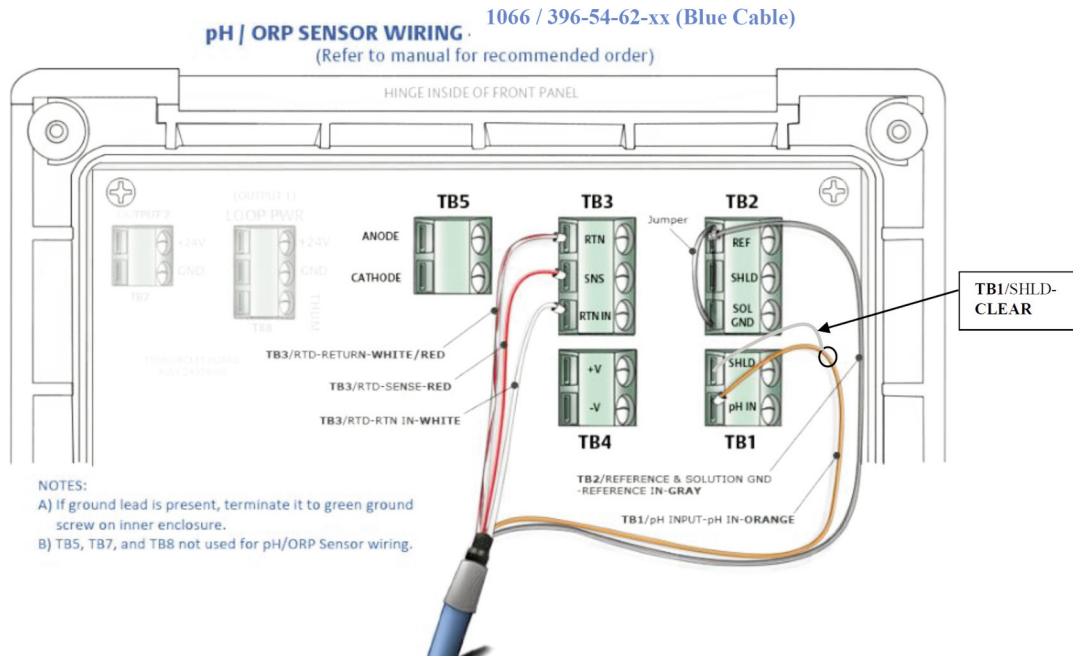



Figure 2-14: Rosemount 396-54-62-xx Wiring to Rosemount 5081 Transmitter

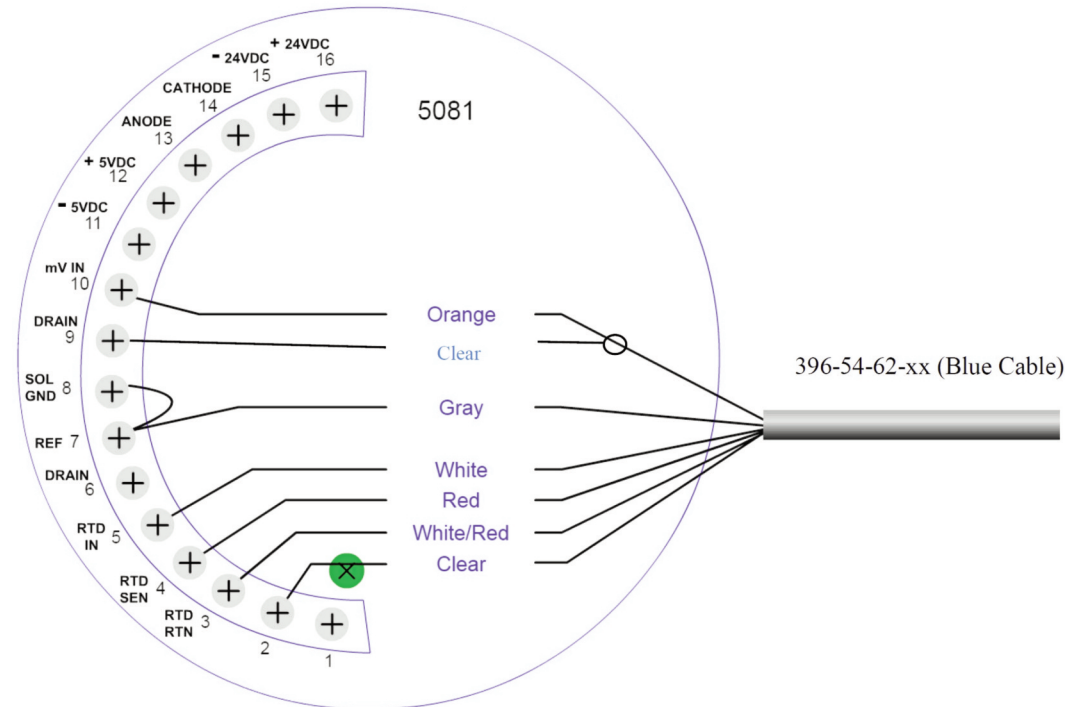

Figure 2-15: Rosemount 396VP Wiring for Rosemount 1056/56 Transmitters

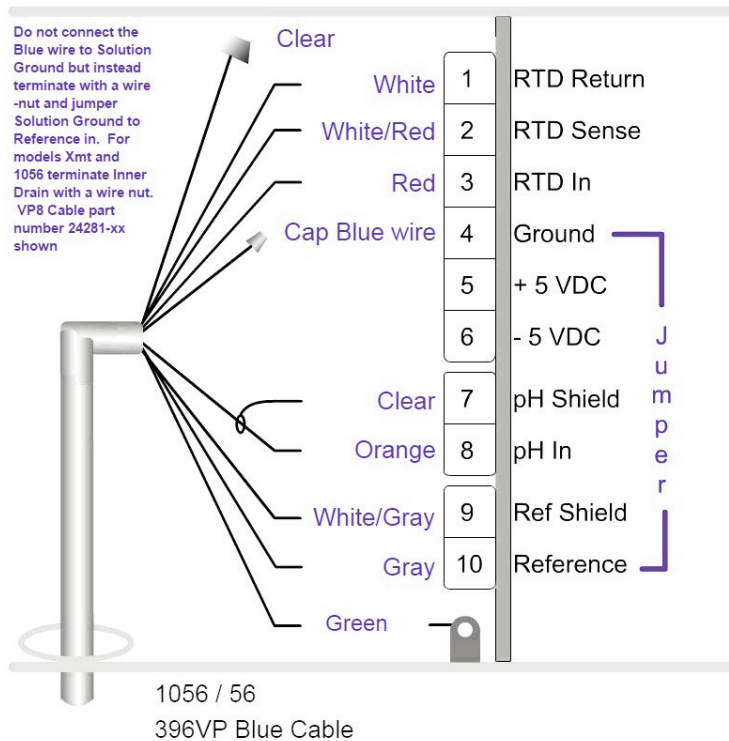

Figure 2-16: Rosemount 396VP Wiring for Rosemount 1066 Transmitter

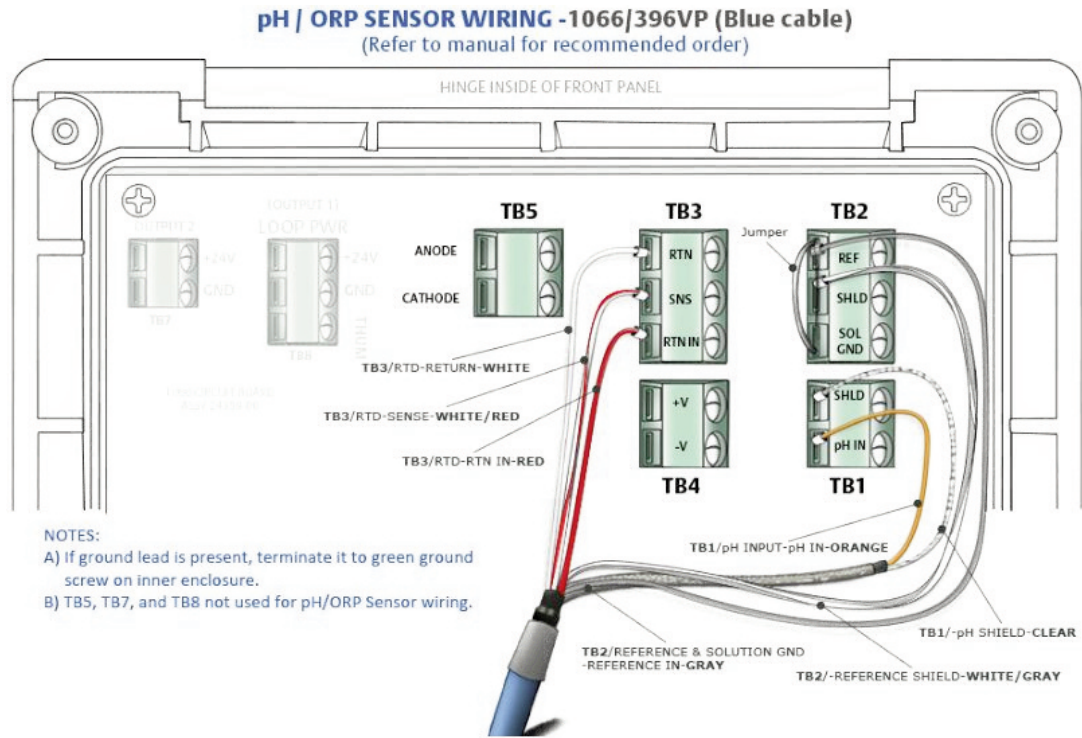

Figure 2-17: Rosemount 396VP Wiring for Rosemount 1057 Transmitter

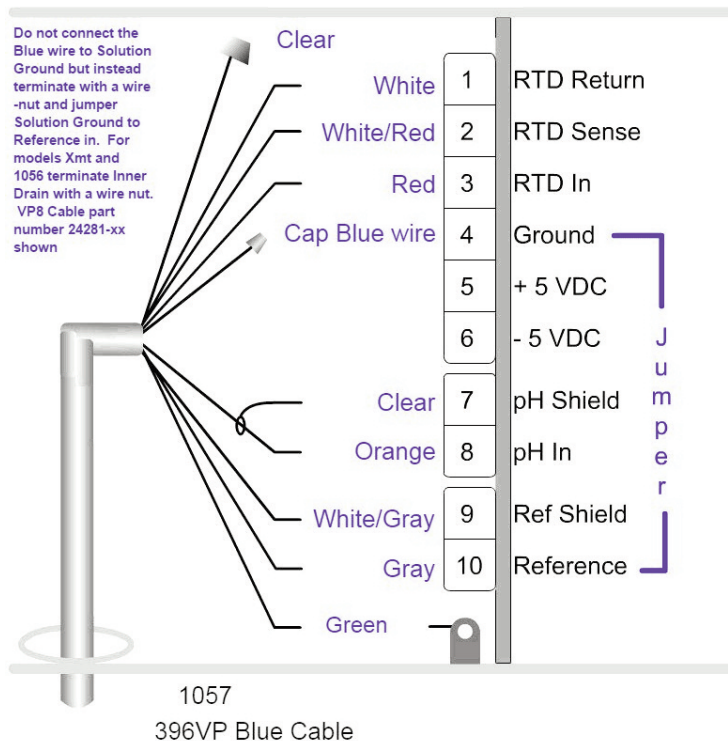

Figure 2-18: Rosemount 396VP Wiring for Rosemount 5081 Transmitter

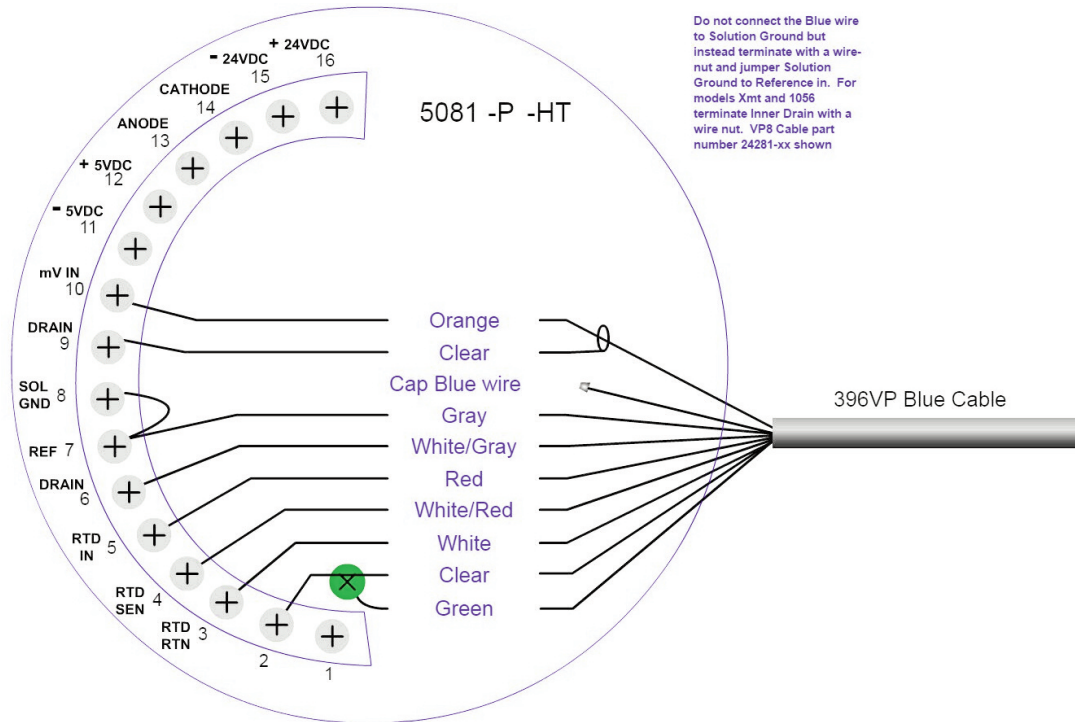

Figure 2-19: Rosemount 396VP-70 Wiring for Rosemount 1066 Transmitter

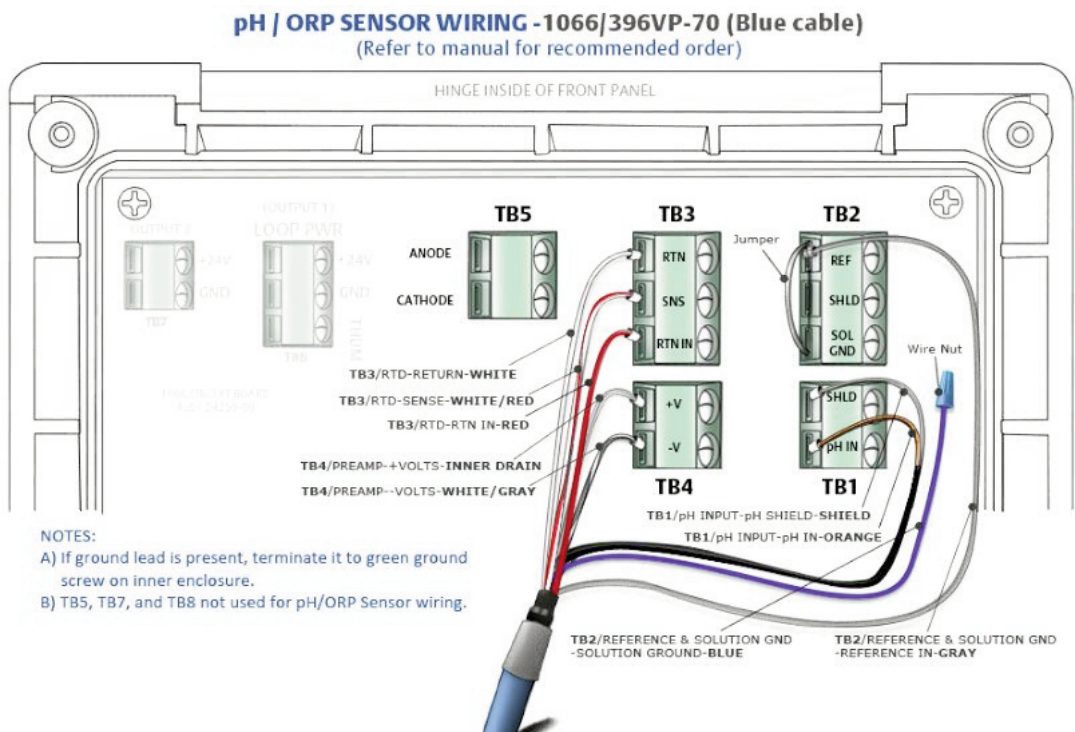

Figure 2-20: Rosemount 396VP-70 Wiring for Rosemount 1056/1057/56 Transmitters

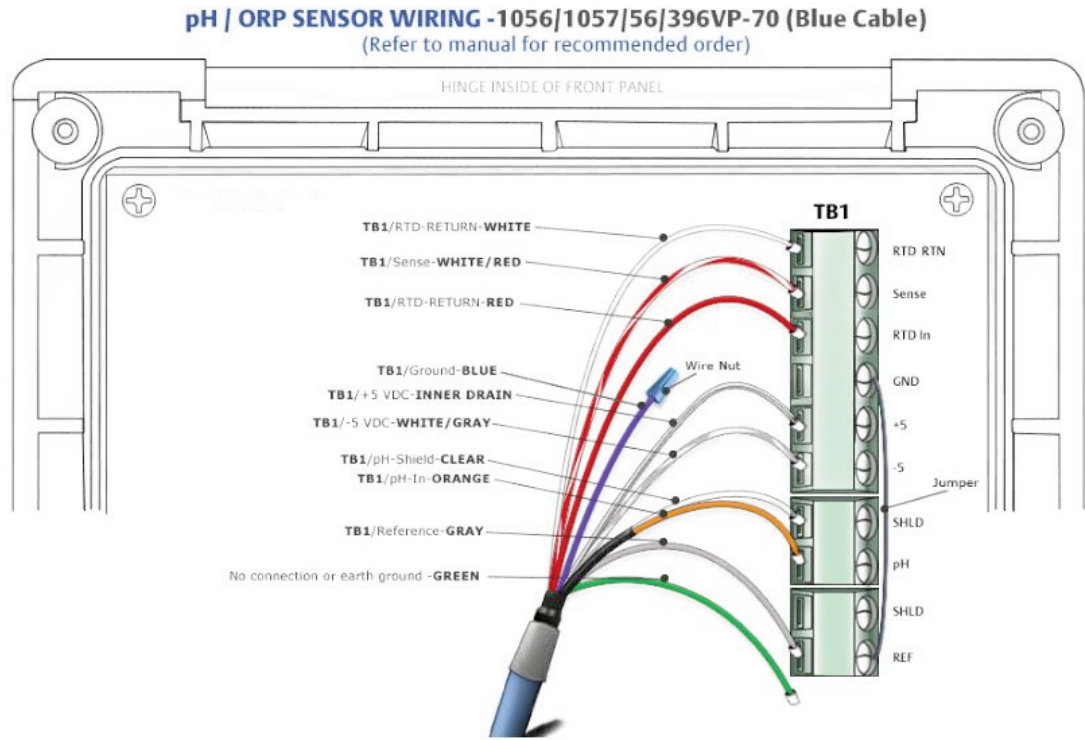

Figure 2-21: Rosemount 397-02-10-54-xx Wiring to Rosemount 1056/1057/56 Transmitter

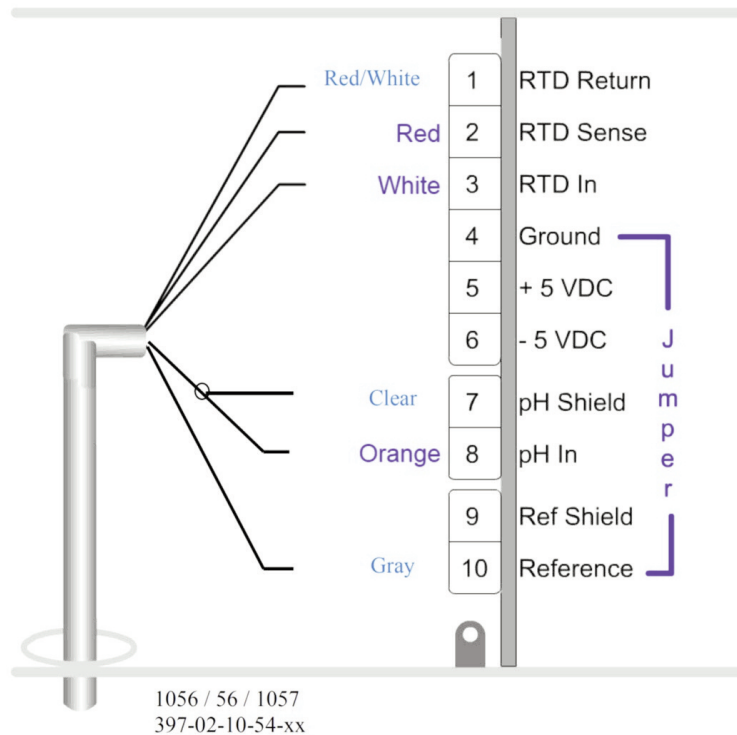



Figure 2-22: Rosemount 397-02-10-54-xx Wiring to Rosemount 1066 Transmitter

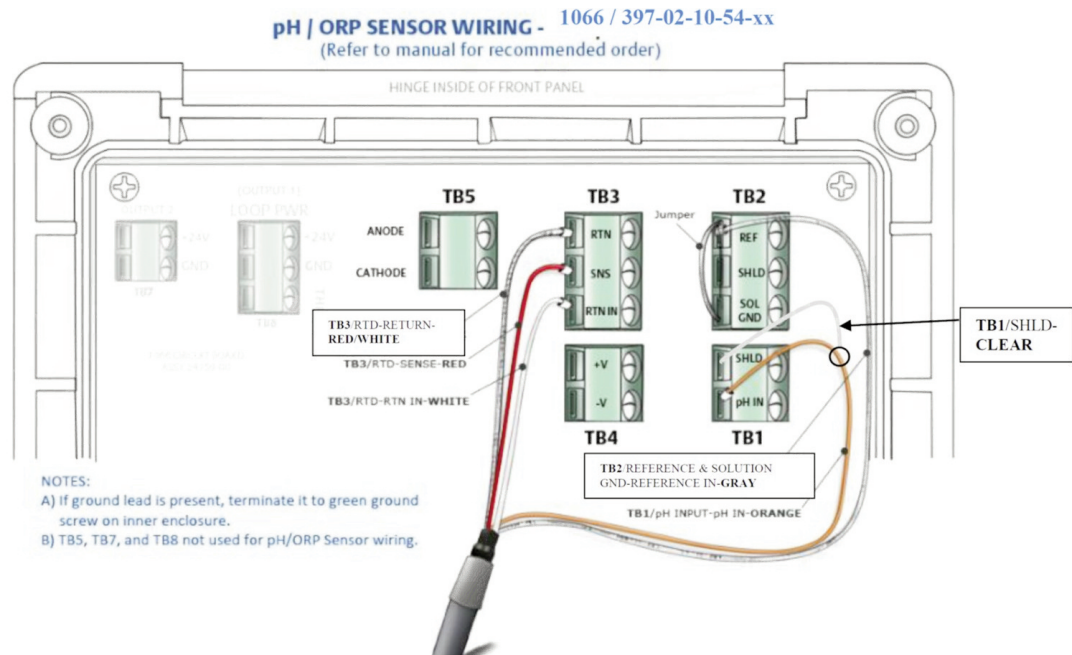

Figure 2-23: Rosemount 397-02-10-54-xx Wiring to Rosemount 5081 Transmitter

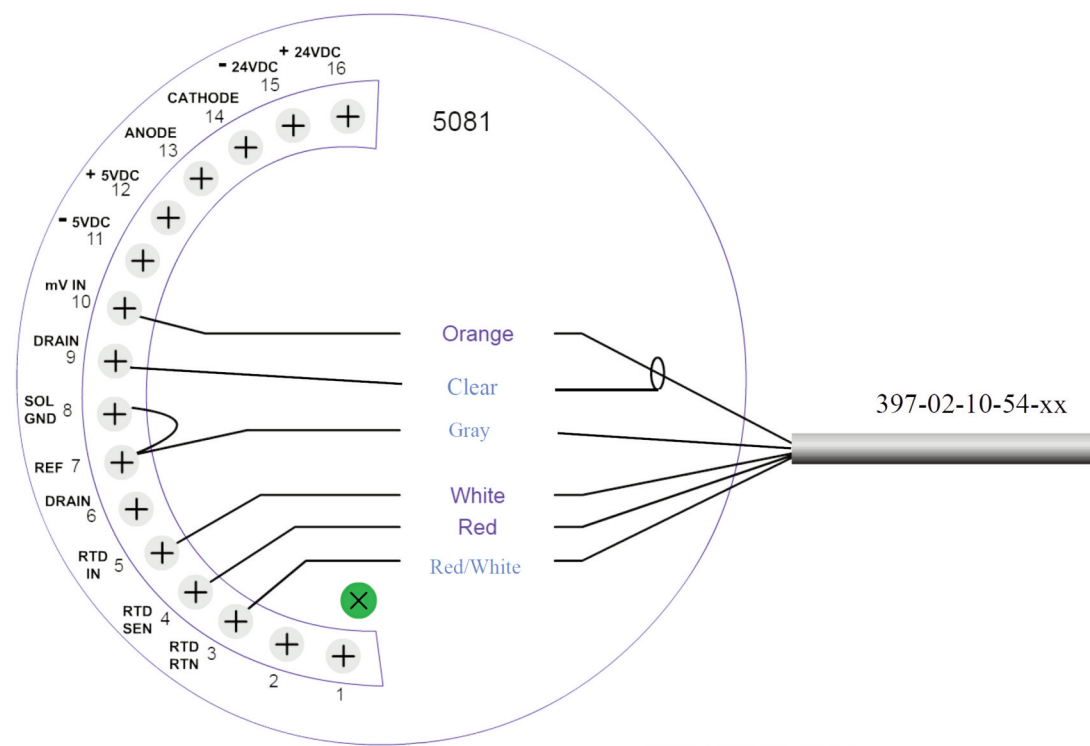



Figure 2-26: Rosemount 398-xx-xx-xx-62 Wiring to Rosemount 5081 Transmitter

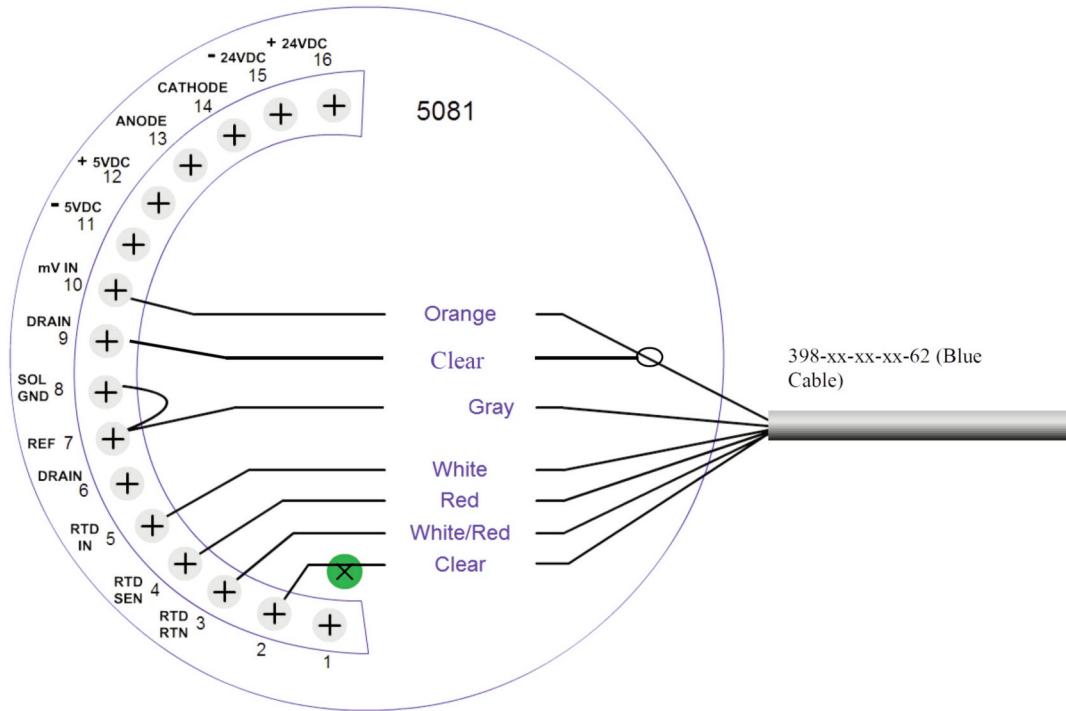

Figure 2-27: Rosemount 398VP Wiring to Rosemount 1056/56 Transmitters

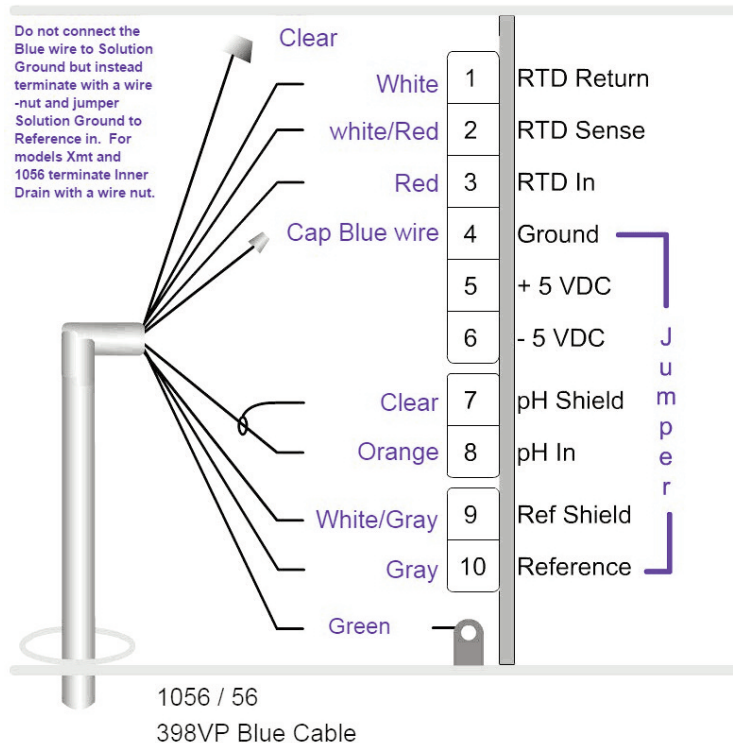

Figure 2-28: Rosemount 398VP Wiring to Rosemount 1057 Transmitter

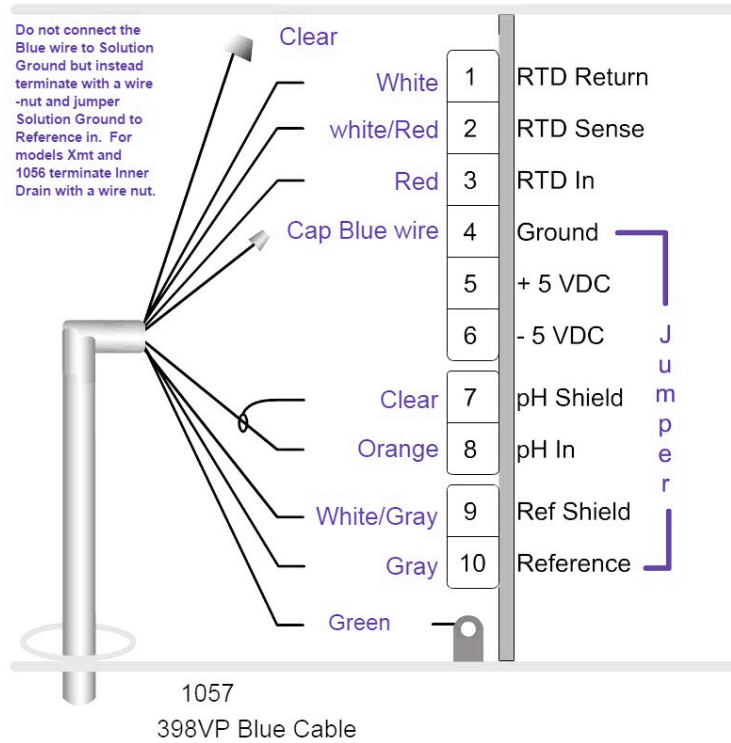

Figure 2-29: Rosemount 398VP Wiring to Rosemount 5081 Transmitter

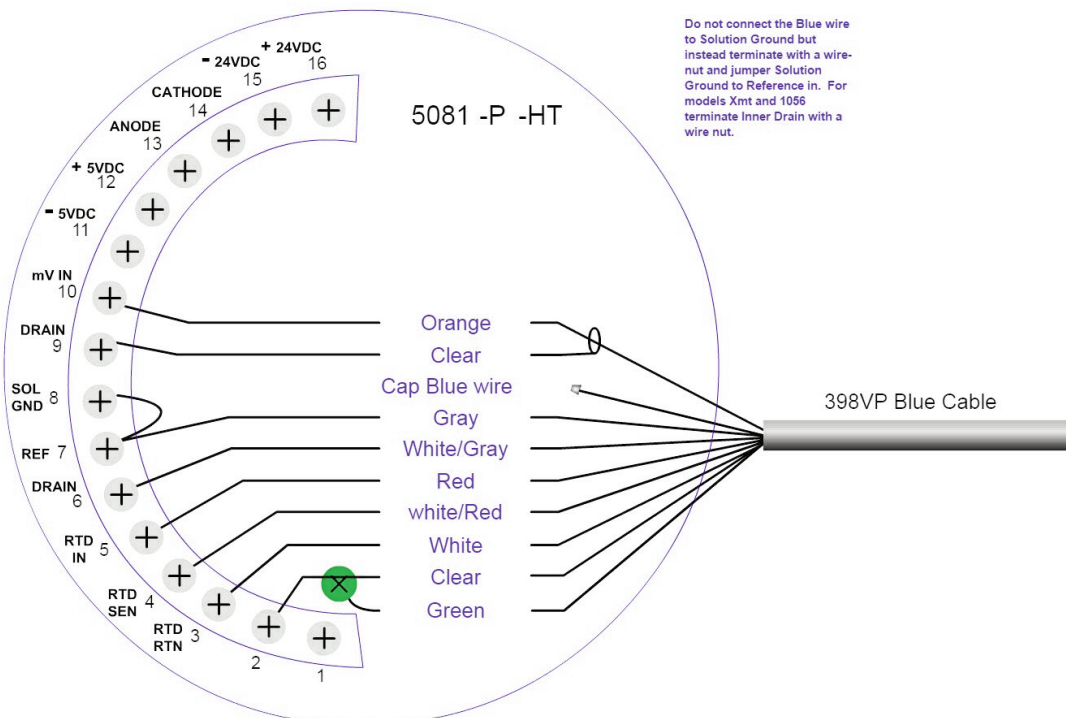
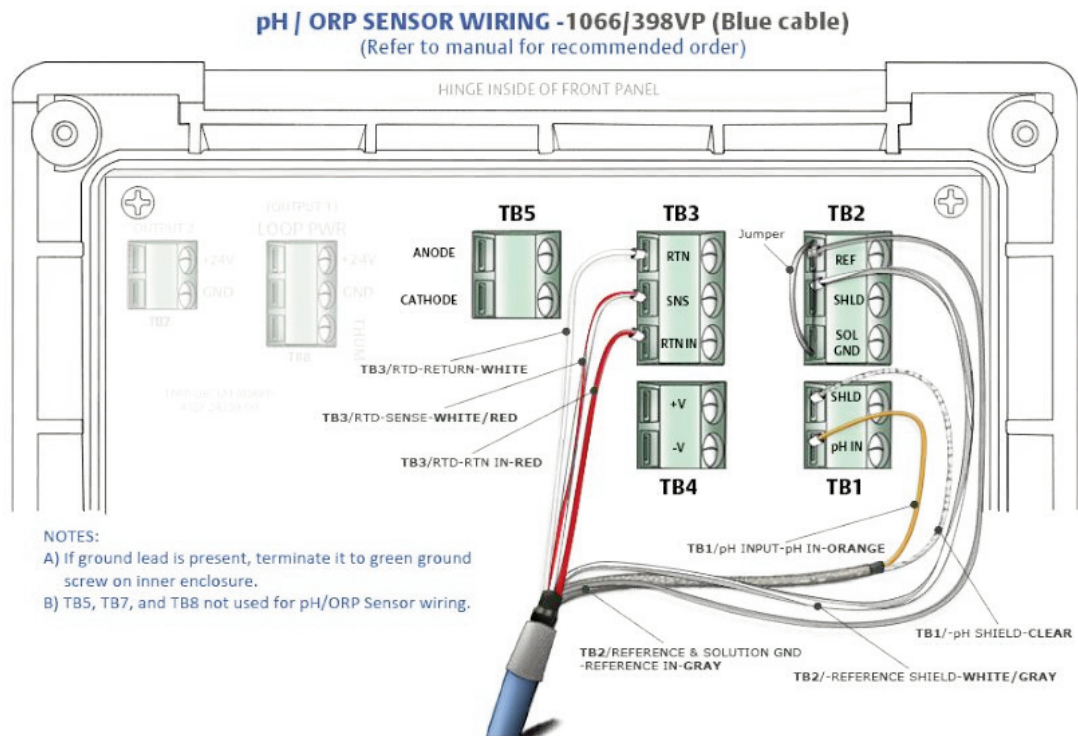



Figure 2-30: Rosemount 398VP Wiring to Rosemount 1066 Transmitter





## Section 3: Startup and Calibration

### 3.1 Sensor Preparation

Shake down the sensor to remove any air bubbles that may be present at the tip of the pH glass bulb. In most cases, the pH sensor can simply be installed as shipped and readings with an accuracy of  $\pm 0.6$  pH may be obtained. To obtain greater accuracy or to verify proper operation, the sensor must be calibrated as a loop with its compatible analyzer or transmitter.

### 3.2 Calibration Using Buffer Solution or Grab Sample

The pH sensor-transmitter loop may be calibrated by submersing the sensor in a buffer solution (standard solutions of known pH values) or in a process grab sample whose pH value maybe checked by a calibrated laboratory or portable pH meter.

Please refer to the transmitter Reference Manual for proper calibration procedures.



## Section 4: Maintenance

the Rosemount 396, 396VP, 397, 398, and 398VP sensors are disposable type sensors and therefore require minimum maintenance. Every sensor should be kept clean and free of debris and sediment at all times. The frequency of cleaning by wiping or brushing with a soft cloth or brush is determined by the nature of the solution being measured. The sensor should be removed from process periodically and checked in buffer solutions.

### DANGER

SENSOR IS IN PRESSURIZED SYSTEM! May cause spray and bodily injury. Before removing sensor, be absolutely certain that the process pressure is reduced to 0 psig and the process temperature is lowered to a safe level.

If the sensor will not calibrate, refer to your transmitter Reference Manual for proper test procedures. If it is determined that the sensor has failed, it should be discarded and replaced.

### 4.1 Electrode Cleaning

If the electrode is coated or dirty, clean as follows:

1. Remove the sensor from process.
2. Wipe the glass bulb with a soft, clean, lint free cloth or tissue. If this does not remove the dirt or coating, go to Step 3. (Detergents clean oil and grease; acids remove scale.)
3. Wash the glass bulb in a strong detergent solution and rinse it in clean water. If this does not clean the glass bulb, go to Step 4.

### CAUTION

The solution used during the following check is an acid and should be handled with care. Follow the directions of the acid manufacturer. Wear the proper protective equipment. Do not let the solution come in contact with skin or clothing. If contact with skin is made, immediately rinse with clean water.

4. Wash the glass bulb in a dilute 5% hydro chloric acid solution and rinse with clean water. Soaking the sensor overnight in the acid solution can improve cleaning action.

### NOTICE

Erroneous pH results may occur immediately after acid soak, due to reference junction potential build-up. Replace the sensor if cleaning does not restore sensor operation.

## 4.2 Automatic Temperature Compensator

The temperature compensator element is temperature sensitive and can be checked with an ohmmeter. Resistance increases with temperature.

The 3K element will read 3000 ohms  $\pm 1\%$  at 25°C (77°F) and a Pt-100 will read 110 ohms. Resistance varies with temperature for a 3K and Pt-100 element and can be determined according to Table 4-2 or the following formula:

$$R_T = R_0 [1 + R_1 (T - 20)]$$

Where  $R_T$  = Resistance

T = Temperature in °C

Refer to Table 4-1 for  $R_0$  and  $R_1$  values

Table 4-1:  $R_0$  and  $R_1$  Values for Temperature Compensation Elements

Temperature Element	$R_0$	$R_1$
3K	2934	0.0045
PT-100	107.7	0.00385

Table 4-2: Temperature vs Resistance of Automatic Temperature Compensator Elements

Temperature °C	Resistance (Ohms) $\pm 1$	
	3K	PT-100
0	2670	100.0
10	2802	103.8
20	2934	107.7
25	3000	109.6
30	3066	111.5
40	3198	115.4
50	3330	119.2
60	3462	123.1
70	3594	126.9
80	3726	130.8
90	3858	134.6
100	3990	138.5

## Section 5: Troubleshooting

Table 5-1: Troubleshooting

Trouble	Probable Cause	Remedy
Meter reads off scale. (Display reads overrange.)	T.C. element shorted.	Check T.C. element as instructed in Section 4.2 and replace sensor if defective.
	Sensor not in process or sample stream is low.	Make sure sensor is in process with sufficient sample stream (refer to Section 2.0 for installation details).
	Open glass electrode.	Replace sensor.
	Reference element open - no contact.	Replace sensor.
Display reads between 3 and 6 pH regardless of actual pH of solution or sample.	Electrode cracked.	Replace sensor.
Meter or display indication swings or jumps widely in AUTO T.C. Mode.	T.C. element shorted.	Check T.C. element as instructed in Section 4.2 and replace sensor if defective.
Span between buffers extremely short in AUTO T.C. Mode.	T.C. element open.	Check T.C. element as instructed in Section 4.2 and replace sensor if defective.
Sluggish or slow meter indication for real changes in pH level.	Electrode coated.	Clean sensor as instructed in Sections 4.1 Replace sensor if cracked.
	Electrode at end of life.	Replace sensor.
Transmitter cannot be standardized.	Electrode coated or cracked.	Clean sensor as instructed in Sections 4.1 Replace sensor if cracked.
Transmitter short spans between two different buffer values.	Electrode at end of life, due to old glass or high temperature exposure.	Replace sensor.
	Coated glass.	Clean sensor as instructed in Sections 4.1 Replace sensor if cracked.

Note: For any repair or warranty inquiries please contact our Customer Care group.





## Section 6: Accessories

### 6.1 Accessories

Table 6-1: Additional Accessories for Rosemount 396/396VP/398/398VP Sensors

Part Number	Description
33046-00	Ferrule 1 in., split 316 SS
33211-00	Adapter retrofit for PN 915240-04
9310100	Ferrule, 1 in. Teflon
9310096	Nut, Swage, 1 in. stainless steel

Table 6-2: Additional Accessories for Rosemount 397 Sensor

Part Number	Description
23753-00	PEEK replacement adapter for Quik-Loc kit (PN 23757-01)
23753-01	PEEK replacement adapter for Quik-Loc kit (PN 23757-00)
9160441	1 in. MNPT 316 stainless steel coupler
9160447	1 in. EP Gasket for coupler
2002011	1-1/2 in. CPVC Tee with 1 in. FNPT Connection



Table 6-3: Other Accessories

Part Number	Description
9210012	Buffer solution, 4.01 pH, 16 oz.
9210013	Buffer solution, 6.86 pH, 16 oz.
9210014	Buffer solution, 9.18 pH, 16 oz.
2001492	Stainless Steel Tag, Specify Marking



# EC Declaration of Conformity

Note: Please see [website](#) for most recent Declaration.

	
<b>EU Declaration of Conformity</b> No: RAD 1119 Rev. B	
<small>pH/ORP Sensors</small>	
We,	
<b>Rosemount Inc.</b> 8200 Market Boulevard Chanhassen, MN 55317-9685 USA	
declare under our sole responsibility that the product,	
<b>Rosemount™ Sensor Models:</b> 328A, 385, 385+ -04, 385+ -02/03, 385+ -03-12, 389-01, 389-01-10/11-50, 389-01-10/11-54, 389-01-12-50, 389-01-12-54, 389-01-12-55, 389-02, 389VP, 389VP-70, 396, 396P-01-10/13-50, 396P-01-10/13-54, 396P-01-12-50, 396P-01-12-54, 396P-01-12-55, 396P-01-55, 396VP, 396VP-70, 396R, 396RVP, 396RVP-70, 396P-02, 396PVP, 396PVP-70, 397, 398, 398VP, 398R, 398RVP, 398RVP-70, 3200HP, 3300HT, 3300HT VP, 3300HTVP-70, 3400HT, 3400HT VP, 3400HTVP-70, 3500P-01, 3500P-01-12, 3500P-02, 3500VP-01, 3500VP-01-12, 3500VP-02, 3800, 3800VP, 3900-01, 3900-02, 3900VP-01, 3900VP-02	
manufactured by,	
<b>Rosemount Inc.</b> 8200 Market Boulevard Chanhassen, MN 55317-9685 USA	
to which this declaration relates, is in conformity with the provisions of the European Union Directives, including the latest amendments, as shown in the attached schedule.	
Assumption of conformity is based on the application of the harmonized standards and, when applicable or required, a European Union notified body certification, as shown in the attached schedule.	
	Vice President of Global Quality
(signature)	(function)
Chris LaPoint	1-Feb-19; Shakopee, MN USA
(name)	(date of issue & place)
Page 1 of 3	



## EU Declaration of Conformity

No: RAD 1119 Rev. B

### ATEX Directive (2014/34/EU)

#### Baseefa10ATEX0156X– Intrinsically Safe

Equipment Group II, Category 1 G Ex ia IIC T4 Ga (-20°C ≤ Ta ≤ +60°C)  
(exceptions noted below)

Model 328 A Steam sterilizable pH sensor with integral cable  
Model 385 Retractable pH/ORP sensor with integral cable  
Model 385+ -04 pH/ORP sensor with integral cable  
Model 385+ -02/03 pH/ORP sensor with integral cable & Smart preamplifier  
Model 385+ -03-12 ORP sensor with integral cable & preamplifier: T4 (-20°C ≤ Ta ≤ +80°C), T5 (-20°C ≤ Ta ≤ +40°C)  
Model 389-01 pH sensor with integral cable & Smart preamplifier  
Model 389-01-10/11-50 pH sensor with integral cable & preamplifier: T4 (-20°C ≤ Ta ≤ +80°C) or T5 (-20°C ≤ Ta ≤ +40°C)  
Model 389-01-10/11-54 pH sensor with integral cable & preamplifier: T4 (-20°C ≤ Ta ≤ +80°C) or T5 (-20°C ≤ Ta ≤ +40°C)  
Model 389-01-12-50 ORP sensor with integral cable & preamplifier: T4 (-20°C ≤ Ta ≤ +80°C)  
Model 389-01-12-54 ORP sensor with integral cable & preamplifier: T4 (-20°C ≤ Ta ≤ +80°C)  
Model 389-01-12-55 ORP sensor with integral cable & preamplifier: T4 (-20°C ≤ Ta ≤ +80°C)  
Model 389-02 pH/ORP sensor with integral cable  
Model 389VP-70 pH sensor with Variopole connector & Smart preamplifier  
Model 389VP pH/ORP sensor with Variopole connector  
Model 396 TU pH sensor with integral cable  
Model 396P-01-10/13-50 polypropylene pH sensor with integral cable & preamp: T4 (-20°C ≤ Ta ≤ +80°C) or T5 (-20°C ≤ Ta ≤ +40°C)  
Model 396P-01-10/13-54 polypropylene pH sensor with integral cable & preamp: T4 (-20°C ≤ Ta ≤ +80°C) or T5 (-20°C ≤ Ta ≤ +40°C)  
Model 396P-01-12-50 ORP sensor with integral cable & preamp: T4 (-20°C ≤ Ta ≤ +80°C)  
Model 396P-01-12-54 ORP sensor with integral cable & preamp: T4 (-20°C ≤ Ta ≤ +80°C)  
Model 396P-01-12-55 ORP sensor with integral cable & preamp: T4 (-20°C ≤ Ta ≤ +80°C)  
Model 396P-01-55 pH sensor with integral cable & Smart preamp  
Model 396VP TU pH sensor with Variopole connector  
Model 396VP-70 TU pH sensor with Variopole connector & Smart preamplifier  
Model 396R TU pH Retractable pH/ORP sensor with integral cable  
Model 396RVP TU pH Retractable pH/ORP sensor with Variopole connector  
Model 396RVP-70 TU pH Retractable pH sensor with Variopole connector & Smart preamplifier  
Model 396P-02 TU pH Polypropylene pH/ORP sensor with integral cable  
Model 396PVP TU pH Polypropylene pH/ORP sensor with Variopole connector  
Model 396PVP-70 TU pH Polypropylene pH sensor with Variopole connector & Smart preamplifier  
Model 397 TU pH sensor with integral cable  
Model 398 TU pH pH/ORP sensor with integral cable  
Model 398VP TU pH pH/ORP sensor with Variopole connector  
Model 398R TU pH Retractable pH/ORP sensor with integral cable  
Model 398RVP TU pH Retractable pH/ORP sensor with Variopole connector  
Model 398RVP-70 TU pH Retractable pH sensor with Variopole connector & Smart preamplifier  
Model 3200HP Flowing junction pH sensor with Variopole connector  
Model 3300HT Insertion/submersion pH sensor with integral cable  
Model 3300HTVP Insertion/submersion pH sensor with Variopole connector



## EU Declaration of Conformity

No: RAD 1119 Rev. B

Model 3300HTVP-70 Insertion/submersion pH sensor with V ariopole connector & Smart preamplifier  
Model 3400HT Retractable pH sensor with integral cable  
Model 3400HTVP Retractable pH sensor with V ariopole connector  
Model 3400HTVP-70 Retractable pH sensor with V ariopole connector & Smart preamplifier  
Model 3500P-01 High performance pH sensor with integral cable & Smart preamplifier  
Model 3500P-01-12 PerpH-X ORP sensor with integral cable & preamplifier: T4 (-20°C ≤ Ta ≤ +80°C)  
Model 3500P-02 High performance pH sensor with integral cable  
Model 3500VP-01 High performance pH sensor with V ariopole connector & Smart preamplifier  
Model 3500VP-01-12 PerpH-X ORP sensor with V ariopole connector & preamplifier: T4 (-20°C ≤ Ta ≤ +80°C)  
Model 3500VP-02 High performance pH sensor with V ariopole connector  
Model 3800 Steam sterilizable pH sensor with single pole Eurocap connector  
CE marking was first affixed to this product in 2011  
Model 3800VP Steam sterilizable pH sensor with V ariopole connector  
Model 3900-01 pH/ORP sensor with integral cable & Smart preamplifier  
Model 3900-02 pH/ORP sensor with integral cable  
Model 3900VP-01 pH sensor with V ariopole connector & Smart preamplifier  
Model 3900VP-02 pH/ORP sensor with V ariopole connector

Special conditions for safe use:

- 1) All pH/ORP sensor models with a plastic enclosure or exposed plastic parts may provide an electrostatic ignition hazard and must only be cleaned with a damp cloth to avoid the danger of ignition due to a buildup of electrostatic charge.
  - 2) All pH/ORP sensor models with a metallic enclosure may provide a risk of ignition by impact or friction. Care should be taken during installation to protect the sensor from this risk.
  - 3) External connections to the sensor must be suitably terminated and provide a degree of protection of at least IP20.
- All pH/ORP sensor models are intended to be in contact with the process fluid and may not meet the 500V r.m.s test to earth. This must be taken into consideration at installation.

Harmonized Standards:  
EN 60079-0:2012+A11:2013  
EN 60079-11:2012

### ATEX Notified Body for EC Type Examination Certificate & Quality Assurance

SGS FIMKO OY [Notified Body Number: 0598]  
P.O. Box 30 (Särkiniementie 3)  
00211 HELSINKI  
Finland

含有China RoHS管控物质超过最大浓度限值的部件型号列表 396  
List of 396 Parts with China RoHS Concentration above MCVs

部件名称 Part Name	有害物质 / Hazardous Substances					
	铅 Lead (Pb)	汞 Mercury (Hg)	镉 Cadmium (Cd)	六价铬 Hexavalent Chromium (Cr +6)	多溴联苯 Polybrominated biphenyls (PBB)	多溴联苯醚 Polybrominated diphenyl ethers (PBDE)
传感器组件 Sensor Assembly	X	O	O	O	O	O

本表格系依据SJ/T11364的规定而制作。

This table is proposed in accordance with the provision of SJ/T11364.

O: 意为该部件的所有均质材料中该有害物质的含量均低于GB/T 26572所规定的限量要求。

O: Indicate that said hazardous substance in all of the homogeneous materials for this part is below the limit requirement of GB/T 26572.

X: 意为在该部件所使用的的所有均质材料里，至少有一类均质材料中该有害物质的含量高于GB/T 26572所规定的限量要求。

X: Indicate that said hazardous substance contained in at least one of the homogeneous materials used for this part is above the limit requirement of GB/T 26572.

部件名称 Part Name	组装备件说明 Spare Parts Descriptions for Assemblies
传感器组件 Sensor Assembly	传感器模块 Sensor Module

含有China RoHS管控物质超过最大浓度限值的部件型号列表 397  
List of 397 Parts with China RoHS Concentration above MCVs

部件名称 Part Name	有害物质 / Hazardous Substances					
	铅 Lead (Pb)	汞 Mercury (Hg)	镉 Cadmium (Cd)	六价铬 Hexavalent Chromium (Cr +6)	多溴联苯 Polybrominated biphenyls (PBB)	多溴联苯醚 Polybrominated diphenyl ethers (PBDE)
电子组件 Electronics Assembly	X	O	O	O	O	O
传感器组件 Sensor Assembly	X	O	O	O	O	O

本表格系依据SJ/T11364的规定而制作。

This table is proposed in accordance with the provision of SJ/T11364.

O: 意为该部件的所有均质材料中该有害物质的含量均低于GB/T 26572所规定的限量要求。

O: Indicate that said hazardous substance in all of the homogeneous materials for this part is below the limit requirement of GB/T 26572.

X: 意为在该部件所使用的所有均质材料里，至少有一类均质材料中该有害物质的含量高于GB/T 26572所规定的限量要求。

X: Indicate that said hazardous substance contained in at least one of the homogeneous materials used for this part is above the limit requirement of GB/T 26572.

部件名称 Part Name	组装备件说明 Spare Parts Descriptions for Assemblies
电子组件 Electronics Assembly	电子线路板组件 Electronic Board Assemblies
传感器组件 Sensor Assembly	传感器模块 Sensor Module

含有China RoHS 管控物质超过最大浓度限值的部件型号列表 398  
List of 398 Parts with China RoHS Concentration above MCVs

部件名称 Part Name	有害物质 / Hazardous Substances					
	铅 Lead (Pb)	汞 Mercury (Hg)	镉 Cadmium (Cd)	六价铬 Hexavalent Chromium (Cr +6)	多溴联苯 Polybrominated biphenyls (PBB)	多溴联苯醚 Polybrominated diphenyl ethers (PBDE)
电子组件 Electronics Assembly	X	O	O	O	O	O
传感器组件 Sensor Assembly	X	O	O	O	O	O

本表格系依据SJ/T11364的规定而制作。

This table is proposed in accordance with the provision of SJ/T11364.

O: 意为该部件的所有均质材料中该有害物质的含量均低于GB/T 26572所规定的限量要求。

O: Indicate that said hazardous substance in all of the homogeneous materials for this part is below the limit requirement of GB/T 26572.

X: 意为在该部件所使用的所有均质材料里，至少有一类均质材料中该有害物质的含量高于GB/T 26572所规定的限量要求。

X: Indicate that said hazardous substance contained in at least one of the homogeneous materials used for this part is above the limit requirement of GB/T 26572.

部件名称 Part Name	组装备件说明 Spare Parts Descriptions for Assemblies
电子组件 Electronics Assembly	电子线路板组件 Electronic Board Assemblies
传感器组件 Sensor Assembly	传感器模块 Sensor Module



# Intrinsically Safe Sensor Installation Drawing - FM

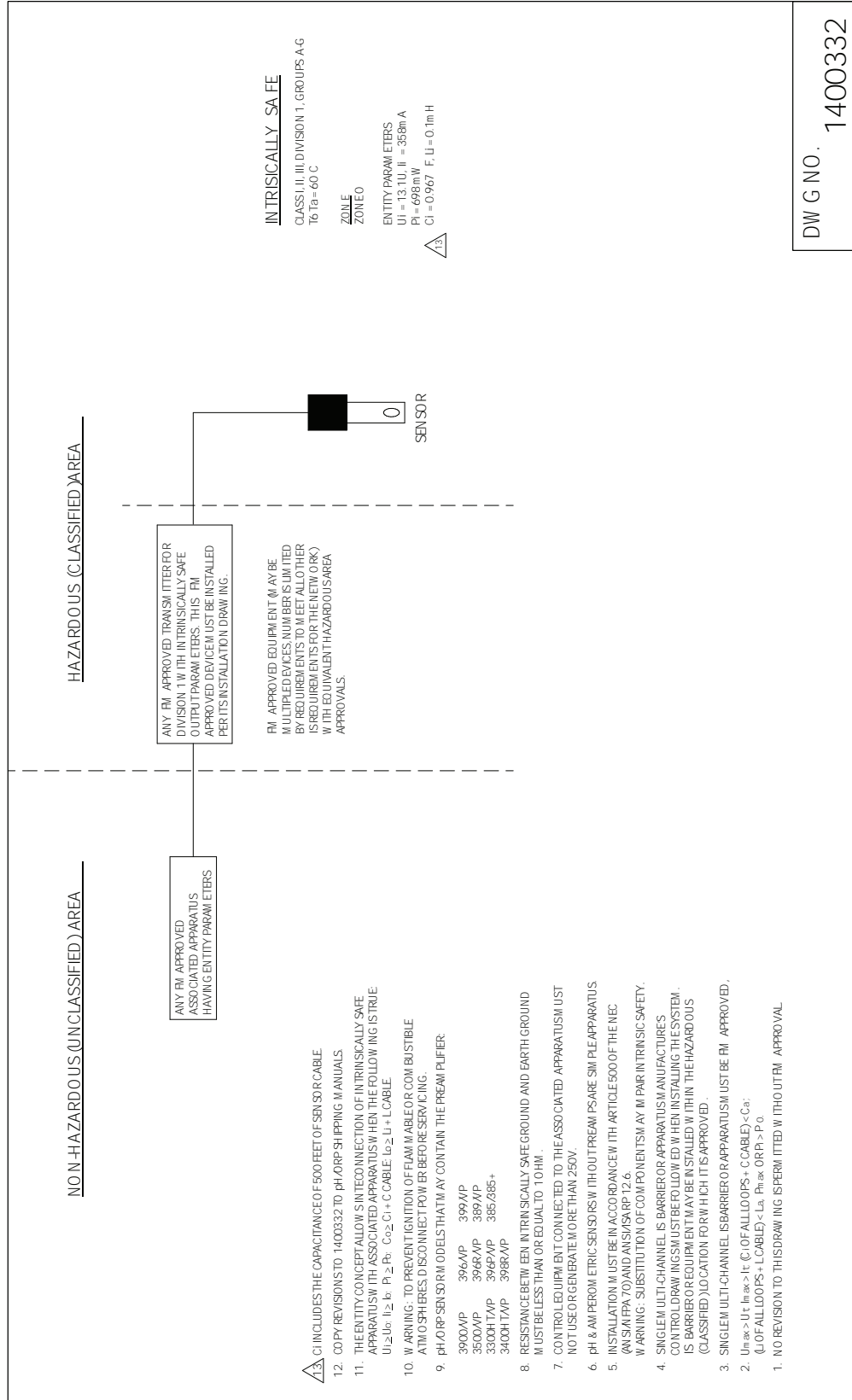

DWG NO. 1400332

[www.Emerson.com/RosemountLiquidAnalysis](http://www.Emerson.com/RosemountLiquidAnalysis)



[Youtube.com/user/Rosemount](https://www.youtube.com/user/Rosemount)



[Twitter.com/Rosemount\\_News](https://twitter.com/Rosemount_News)



[facebook.com/Rosemount](https://facebook.com/Rosemount)

**Emerson**

8200 Market Blvd.  
Chanhassen, MN 55317,  
USA  
Tel +1 800 999 9307  
Fax +1 952 949 7001  
[Liquid.CSC@Emerson.com](mailto:Liquid.CSC@Emerson.com)

©2019 Emerson. All rights reserved.

The Emerson logo is a trademark and service mark of Emerson Electric Co. Rosemount is a mark of one of the Emerson family of companies. All other marks are the property of their respective owners.

The contents of this publication are presented for information purposes only, and while effort has been made to ensure their accuracy, they are not to be construed as warranties or guarantees, express or implied, regarding the products or services described herein or their use or applicability. All sales are governed by our terms and conditions, which are available on request. We reserve the right to modify or improve the designs or specifications of our products at any time without notice.

**ROSEMOUNT™**

