



# Lenovo 65W DC Travel Adapter

<http://www.lenovo.com/support>



PN: 0A33593  
Printed in China

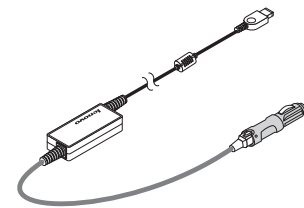
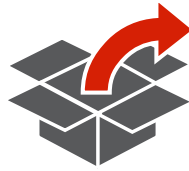

1

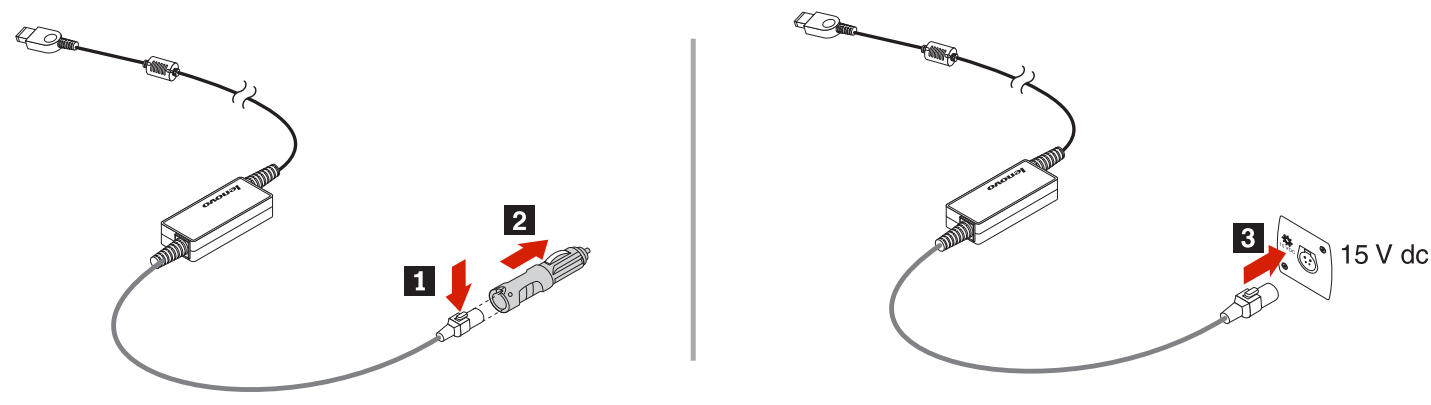
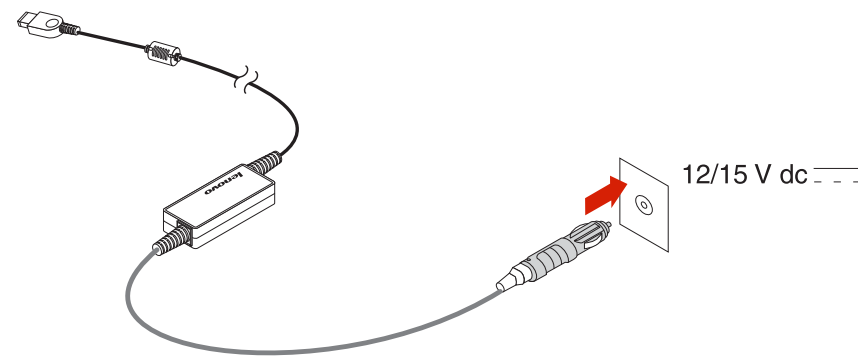

2

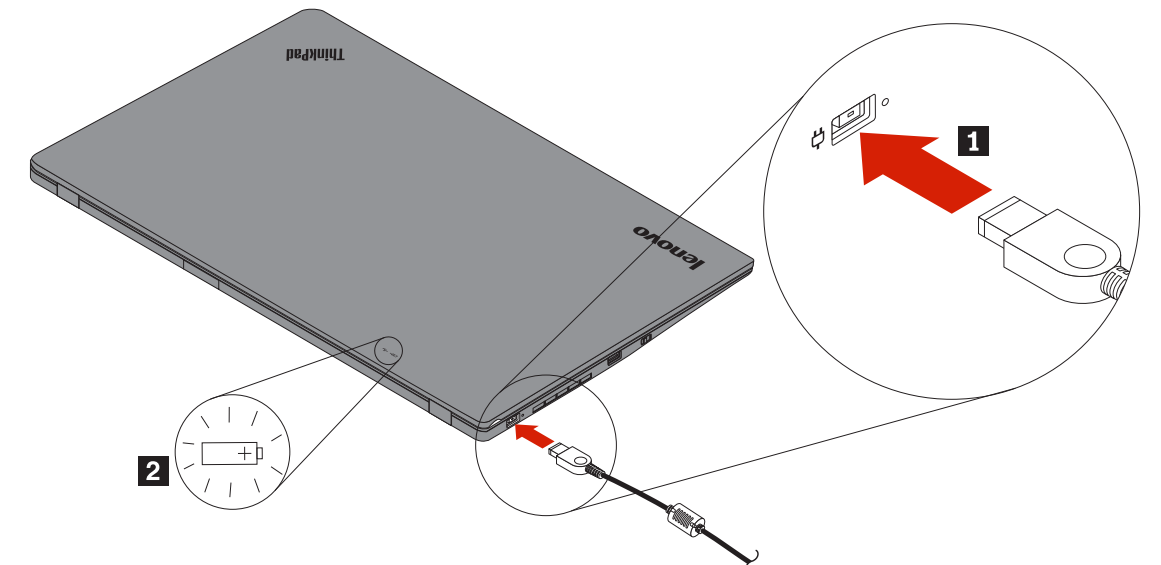

## 65W DC Travel Adapter Fuse Replacement

1

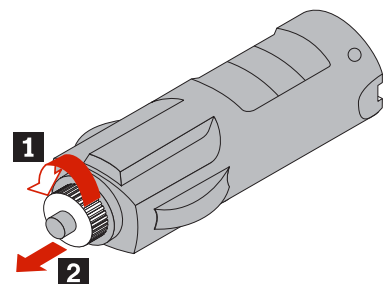
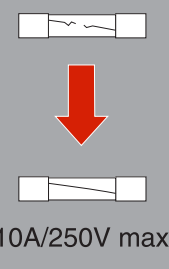

2

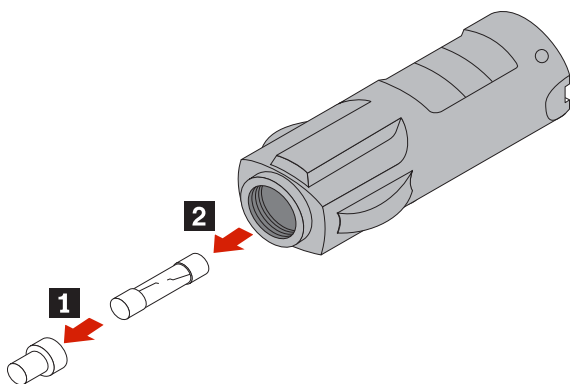

3

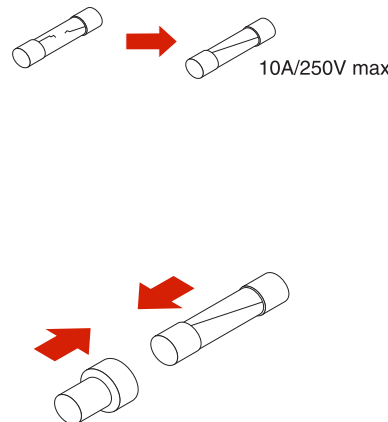

4

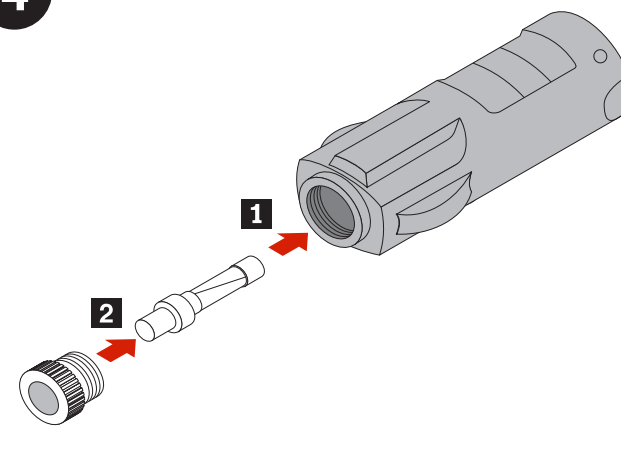

5

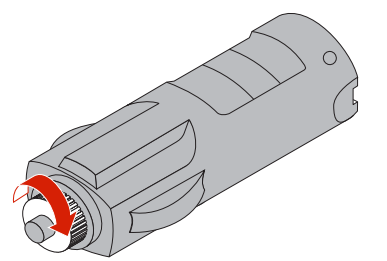

<http://www.lenovo.com/safety>

### Service and Support

The following information describes the technical support that is available for your product, during the warranty period or throughout the life of your product. Refer to the Lenovo Limited Warranty for a full explanation of Lenovo warranty terms.

#### Online technical support

Product replacement assistance or exchange of defective components also is available during the warranty period. In addition, if your option is installed in a Lenovo computer, you might be entitled to service at your location. A Lenovo technical support representative can help you determine the best alternative.

#### Telephone technical support

Installation and configuration support through the Customer Support Center will be available until 90 days after the option has been withdrawn from marketing. After that time, the support is canceled, or made available for a fee, at Lenovo's discretion. Additional support is also available for a nominal fee.

Before contacting a Lenovo technical support representative, please have the following information available: option name and number, proof of purchase, computer manufacturer, model, serial number and manual, the exact wording of any error message, description of the problem, and the hardware and software configuration information for your system.

Your technical support representative might want to walk you through the problem while you are at your computer during the call.

Telephone numbers are subject to change without notice. The most up-to-date telephone list for Lenovo Support is always available at <http://www.lenovo.com/support/phone>. If the telephone number for your country or region is not listed, contact your Lenovo reseller or Lenovo marketing representative.

### Lenovo Limited Warranty

L505-0010-02 08/2011

This Lenovo Limited Warranty consists of the following parts:

#### Part 1 - General Terms

#### Part 2 - Country-specific Terms

#### Part 3 - Warranty Service Information

The terms of Part 2 replace or modify terms of Part 1 as specified for a particular country.

#### Part 1 - General Terms

This Lenovo Limited Warranty applies only to Lenovo hardware products you purchased for your own use and not for resale.

This Lenovo Limited Warranty is available in other languages at [www.lenovo.com/warranty](http://www.lenovo.com/warranty).

Reduce | Reuse | Recycle

#### What this Warranty Covers

Lenovo warrants that each Lenovo hardware product that you purchase is free from defects in materials and workmanship under normal use during the warranty period. The warranty period for the product starts on the original date of purchase as shown on your sales receipt or invoice or as may be otherwise specified by Lenovo. The warranty period and type of warranty service that apply to your product are as specified in "Part 3 - Warranty Service Information" below. This warranty only applies to products in the country or region of purchase.

**THIS WARRANTY IS YOUR EXCLUSIVE WARRANTY AND REPLACES ALL OTHER WARRANTIES OR CONDITIONS, EXPRESS OR IMPLIED, INCLUDING, BUT NOT LIMITED TO, ANY IMPLIED WARRANTIES OR CONDITIONS OF MERCHANTABILITY OR FITNESS FOR A PARTICULAR PURPOSE. AS SOME STATES OR JURISDICTIONS DO NOT ALLOW THE EXCLUSION OF EXPRESS OR IMPLIED WARRANTIES, THE ABOVE EXCLUSION MAY NOT APPLY TO YOU. IN THAT EVENT, SUCH WARRANTIES APPLY ONLY TO THE EXTENT AND FOR SUCH DURATION AS REQUIRED BY LAW AND ARE LIMITED IN DURATION TO THE WARRANTY PERIOD. AS SOME STATES OR JURISDICTIONS DO NOT ALLOW LIMITATIONS ON THE DURATION OF AN IMPLIED WARRANTY, THE ABOVE LIMITATION ON DURATION MAY NOT APPLY TO YOU.**

#### How to Obtain Warranty Service

If the product does not function as warranted during the warranty period, you may obtain warranty service by contacting Lenovo or a Lenovo approved Service Provider. A list of approved Service Providers and their telephone numbers is available at: [www.lenovo.com/support/phone](http://www.lenovo.com/support/phone).

Warranty service may not be available in all locations and may differ from location to location. Charges may apply outside a Service Provider's normal service area. Contact a local Service Provider for information specific to your location.

#### Customer Responsibilities for Warranty Service

Before warranty service is provided, you must take the following steps:

- Follow the service request procedures specified by the Service Provider.
- Backup or secure all programs and data contained in the product.
- Provide the Service Provider with all system keys or passwords.
- Provide the Service Provider with sufficient, free, and safe access to your facilities to perform service.
- Remove all data, including confidential information, proprietary information and personal information, from the product or, if you are unable to remove any such information, modify the information to prevent its access by another party or so that it is not personal data under applicable law. The Service Provider shall not be responsible for the loss or disclosure of any data, including confidential information, proprietary information, or personal information, on a product returned or accessed for warranty service.
- Remove all features, parts, options, alterations, and attachments not covered by the warranty.
- Ensure that the product or part is free of any legal restrictions that prevent its replacement.
- If you are not the owner of a product or part, obtain authorization from the owner for the Service Provider to provide warranty service.

#### What Your Service Provider Will Do to Correct Problems

When you contact a Service Provider, you must follow the specified problem

determination and resolution procedures.

The Service Provider will attempt to diagnose and resolve your problem by telephone, e-mail or remote assistance. The Service Provider may direct you to download and install designated software updates.

Some problems may be resolved with a replacement part that you install yourself called a "Customer Replaceable Unit" or "CRU." If so, the Service Provider will ship the CRU to you for you to install.

If your problem cannot be resolved over the telephone, through the application of software updates or the installation of a CRU, the Service Provider will arrange for service under the type of warranty service designated for the product under "Part 3 - Warranty Service Information" below.

If the Service Provider determines that it is unable to repair your product, the Service Provider will replace it with one that is at least functionally equivalent.

If the Service Provider determines that it is unable to either repair or replace your product, your sole remedy under this Limited Warranty is to return the product to your place of purchase or to Lenovo for a refund of your purchase price.

#### Replacement Products and Parts

When warranty service involves the replacement of a product or part, the replaced product or part becomes Lenovo's property and the replacement product or part becomes your property. Only unaltered Lenovo products and parts are eligible for replacement. The replacement product or part provided by Lenovo may not be new, but it will be in good working order and at least functionally equivalent to the original product or part. The replacement product or part shall be warranted for the balance of the period remaining on the original product.

#### Use of Personal Contact Information

If you obtain service under this warranty, you authorize Lenovo to store, use and process information about your warranty service and your contact information, including name, phone numbers, address, and e-mail address. Lenovo may use this information to perform service under this warranty. We may contact you to inquire about your satisfaction with our warranty service or to notify you about any product recalls or safety issues. In accomplishing these purposes, you authorize Lenovo to transfer your information to any country where we do business and to provide it to entities acting on our behalf. We may also disclose it where required by law. Lenovo's privacy policy is available at [www.lenovo.com/](http://www.lenovo.com/).

#### What this Warranty Does not Cover

This warranty does not cover the following:

- Uninterrupted or error-free operation of a product.
- Loss of, or damage to, your data by a product.
- Any software programs, whether provided with the product or installed subsequently.
- Failure or damage resulting from misuse, abuse, accident, modification, unsuitable physical or operating environment, natural disasters, power surges, improper maintenance, or use not in accordance with product information materials.
- Damage caused by a non-authorized service provider.
- Failure of, or damage caused by, any third party products, including those that Lenovo may provide or integrate into the Lenovo product at your request.
- Any technical or other support, such as assistance with "how-to" questions and those regarding product set-up and installation.

- Products or parts with an altered identification label or from which the identification label has been removed.

#### Limitation of Liability

Lenovo is responsible for loss or damage to your product only while it is in the Service Provider's possession or in transit, if the Service Provider is responsible for the transportation.

Neither Lenovo nor the Service Provider is responsible for loss or disclosure of any data, including confidential information, proprietary information, or personal information, contained in a product.

**UNDER NO CIRCUMSTANCES, AND NOTWITHSTANDING THE FAILURE OF ESSENTIAL PURPOSE OF ANY REMEDY SET FORTH HEREIN, SHALL LENOVO, ITS AFFILIATES, SUPPLIERS, RESELLERS, OR SERVICE PROVIDERS BE LIABLE FOR ANY OF THE FOLLOWING EVEN IF INFORMED OF THEIR POSSIBILITY AND REGARDLESS OF WHETHER THE CLAIM IS BASED IN CONTRACT, WARRANTY, NEGLIGENCE, STRICT LIABILITY OR OTHER THEORY OF LIABILITY: 1) THIRD PARTY CLAIMS AGAINST YOU FOR DAMAGES; 2) LOSS, DAMAGE OR DISCLOSURE OF YOUR DATA; 3) SPECIAL, INCIDENTAL, PUNITIVE, INDIRECT OR CONSEQUENTIAL DAMAGES, INCLUDING BUT NOT LIMITED TO LOST PROFITS, BUSINESS REVENUE, GOODWILL OR ANTICIPATED SAVINGS. IN NO CASE SHALL THE TOTAL LIABILITY OF LENOVO, ITS AFFILIATES, SUPPLIERS, RESELLERS OR SERVICE PROVIDERS FOR DAMAGES FROM ANY CAUSE EXCEED THE AMOUNT OF ACTUAL DIRECT DAMAGES, NOT TO EXCEED THE AMOUNT PAID FOR THE PRODUCT.**

**THE FOREGOING LIMITATIONS DO NOT APPLY TO DAMAGES FOR BODILY INJURY (INCLUDING DEATH), DAMAGE TO REAL PROPERTY OR DAMAGE TO TANGIBLE PERSONAL PROPERTY FOR WHICH LENOVO IS LIABLE UNDER LAW.**

**AS SOME STATES OR JURISDICTIONS DO NOT ALLOW THE EXCLUSION OR LIMITATION OF INCIDENTAL OR CONSEQUENTIAL DAMAGES, THE ABOVE LIMITATION OR EXCLUSION MAY NOT APPLY TO YOU.**

#### Your Other Rights

**THIS WARRANTY GIVES YOU SPECIFIC LEGAL RIGHTS. YOU MAY HAVE OTHER RIGHTS ACCORDING TO THE APPLICABLE LAWS OF YOUR STATE OR JURISDICTION. YOU MAY ALSO HAVE OTHER RIGHTS UNDER A WRITTEN AGREEMENT WITH LENOVO. NOTHING IN THIS WARRANTY AFFECTS STATUTORY RIGHTS, INCLUDING RIGHTS OF CONSUMERS UNDER LAWS OR REGULATIONS GOVERNING THE SALE OF CONSUMER GOODS THAT CANNOT BE WAIVED OR LIMITED BY CONTRACT.**

#### Part 2 - Country-specific Terms

##### Australia

"Lenovo" means Lenovo (Australia & New Zealand) Pty Limited ABN 70 112 394 411. Address: Level 10, North Tower, 1-5 Railway Street, Chatswood, NSW, 2067. Telephone: +61 2 8003 8200. Email: [lenusyd\\_au@lenovo.com](mailto:lenusyd_au@lenovo.com)

The following replaces the same section in Part 1:

#### What this Warranty Covers:

Lenovo warrants that each hardware product that you purchase is free from defects in materials and workmanship under normal use and conditions during the warranty period. If the product fails due to a covered defect during the warranty period, Lenovo will provide you a remedy under this Limited Warranty. The warranty period for the

product starts on the original date of purchase specified on your sales receipt or invoice unless Lenovo informs you otherwise in writing. The warranty period and type of warranty service that apply to your product are set forth below in Part 3 - Warranty Service Information.

**THE BENEFITS GIVEN BY THIS WARRANTY ARE IN ADDITION TO YOUR RIGHTS AND REMEDIES AT LAW, INCLUDING THOSE UNDER THE AUSTRALIAN CONSUMER LAW.**

The following replaces the same section in Part 1:

#### Replacement Products and Parts:

When warranty service involves the replacement of a product or part, the replaced product or part becomes Lenovo's property and the replacement product or part becomes your property. Only unaltered Lenovo products and parts are eligible for replacement. The replacement product or part provided by Lenovo may not be new, but it will be in good working order and at least functionally equivalent to the original product or part. The replacement product or part shall be warranted for the balance of the period remaining on the original product. Products and parts presented for repair may be replaced by refurbished products or parts of the same type rather than being repaired. Refurbished parts may be used to repair the product; and repair of the product may result in loss of data, if the product is capable of retaining user-generated data.

The following is added to the same section in Part 1:

#### Use of Personal Contact Information:

Lenovo will not be able to perform our service under this warranty if you refuse to provide your information or do not wish us to transfer your information to our agent or contractor. You have the right to access your personal contact information and request correction of any errors in it pursuant to the Privacy Act 1988 by contacting Lenovo.

The following replaces the same section in Part 1:

#### Limitation of Liability:

Lenovo is responsible for loss or damage to your product only while it is in the Service Provider's possession or in transit, if the Service Provider is responsible for the transportation.

Neither Lenovo nor the Service Provider is responsible for loss or disclosure of any data, including confidential information, proprietary information, or personal information, contained in a product.

**TO THE EXTENT PERMITTED BY LAW, UNDER NO CIRCUMSTANCES AND NOTWITHSTANDING THE FAILURE OF ESSENTIAL PURPOSE OF ANY REMEDY SET FORTH HEREIN, SHALL LENOVO, ITS AFFILIATES, SUPPLIERS, RESELLERS, OR SERVICE PROVIDERS BE LIABLE FOR ANY OF THE FOLLOWING EVEN IF INFORMED OF THEIR POSSIBILITY AND REGARDLESS OF WHETHER THE CLAIM IS BASED IN CONTRACT, WARRANTY, NEGLIGENCE, STRICT LIABILITY OR OTHER THEORY OF LIABILITY: 1) THIRD PARTY CLAIMS AGAINST YOU FOR DAMAGES; 2) LOSS, DAMAGE OR DISCLOSURE OF YOUR DATA; 3) SPECIAL, INCIDENTAL, PUNITIVE, INDIRECT OR CONSEQUENTIAL DAMAGES, INCLUDING BUT NOT LIMITED TO LOST PROFITS, BUSINESS REVENUE, GOODWILL OR ANTICIPATED SAVINGS. IN NO CASE SHALL THE TOTAL LIABILITY OF LENOVO, ITS AFFILIATES, SUPPLIERS, RESELLERS OR SERVICE PROVIDERS FOR DAMAGES FROM ANY CAUSE EXCEED THE AMOUNT OF ACTUAL DIRECT DAMAGES, NOT TO EXCEED THE AMOUNT PAID FOR THE PRODUCT.**

**THE FOREGOING LIMITATIONS DO NOT APPLY TO DAMAGES FOR BODILY INJURY (INCLUDING DEATH), DAMAGE TO REAL PROPERTY OR DAMAGE TO TANGIBLE PERSONAL PROPERTY FOR WHICH LENOVO IS LIABLE UNDER**



**LLW.**

*The following replaces the same section in Part 1:*

**Your Other Rights:**
**THIS WARRANTY GIVES YOU SPECIFIC LEGAL RIGHTS. YOU ALSO HAVE OTHER RIGHTS AT LAW, INCLUDING UNDER THE AUSTRALIAN CONSUMER LAW.**

**NOTHING IN THIS WARRANTY AFFECTS STATUTORY RIGHTS OR RIGHTS AT LAW, INCLUDING RIGHTS THAT CANNOT BE WAIVED OR LIMITED BY CONTRACT.**

For example, our products come with guarantees that cannot be excluded under the Australian Consumer Law. You are entitled to a replacement or refund for a major failure and compensation for any other reasonably foreseeable loss or damage. You are also entitled to have the products repaired or replaced if the products fail to be of acceptable quality and the failure does not amount to a major failure.

**New Zealand**

*The following is added to the same section in Part 1:*

**Use of Personal Information:**

Lenovo will not be able to perform our service under this warranty if you refuse to provide your information or do not wish us to transfer your information to our agent or contractor. You have the right to access your personal information and request correction of any errors in pursuant to the Privacy Act 1993 by contacting Lenovo (Australia & New Zealand) Pty Limited ABN 70 112 394 411. Address: Level 10, North Tower, 1-5 Railway Street, Chatswood, NSW, 2067. Telephone: 61 2 8003 8200. Email: lenস্যd\_au@lenovo.com

**Bangladesh, Cambodia, India, Indonesia, Nepal, Philippines, Vietnam and Sri Lanka**

**Col. Cruz Manca**

*The following is added to Part 1:*

**Dispute Resolution**

Disputes arising out of or in connection with this warranty shall be finally settled by arbitration held in Singapore. This warranty shall be governed, construed and enforced in accordance with the laws of Singapore, without regard to conflict of laws. If you acquired the product in **India**, dispute arising out of or in connection with this warranty shall be finally settled by arbitration held in Bangalore, India. Arbitration in Singapore shall be held in accordance with the Arbitration Rules of Singapore International Arbitration Center (“SIAC Rules”) then in effect. Arbitration in India shall be held in accordance with the Arbitration and Conciliation Act, 1996. An award shall be final and binding on the parties without appeal. Any award shall be in writing and set forth the findings of fact and the conclusions of law. All arbitration proceedings, including all documents presented in such proceedings shall be conducted in the English language. The English language version of this warranty prevails over any other language version in such proceedings.

**European Economic Area (EEA)**

*The following is added to Part 1:*

Customers in the EEA may contact Lenovo at the following address: EMEA Service Organisation, Lenovo (International) S.V., Floor 2, Einsteinlaan 21, 8511 D3, Bratislava, Slovakia. Service under this warranty for Lenovo hardware products purchased in EEA countries may be obtained in any EEA country in which the product has been announced and made available by Lenovo.

**Russia**

*The following is added to Part 1:*

**Product Service Life**

The product service life is four (4) years from the original date of purchase.

### Part 3 - Warranty Service Information

Product Type	Country or Region of Purchase	Warranty Period	Type of Warranty Service
Lenovo® 65W DC Travel Adapter	Worldwide	1 year	1, 4

If required, the Service Provider will provide repair or exchange service depending on the type of warranty service specified for your product and the available service.

Scheduling of service will depend upon the time of your call, parts availability, and other factors.

**Types of Warranty Service**

**1. Customer Replaceable Unit (“CRU”) Service**

Under CRU Service, the Service Provider will ship CRUs to you at its cost for installation by you. CRU information and replacement instructions are shipped with your product and are available from Lenovo at any time upon request. CRUs that are easily installed by you are called “Self-service CRUs”. Optional-service CRUs are CRUs that may require some technical skill and tools. Installation of Self-service CRUs is your responsibility. You may request that a Service Provider install Optional-service CRUs under one of the other types of warranty service designated for your product. An optional service offering may be available for purchase from a Service Provider or Lenovo under which Self-service CRUs would be installed for you. You may find a list of CRUs and their designation in the publication that was shipped with your product at <http://www.lenovo.com/CRUs>. The requirement to return a defective CRU, if any, will be specified in the instructions shipped with a replacement CRU. When return is required: 1) return instructions, a prepaid return shipping label, and a container will be included with the replacement CRU; and 2) you may be charged for the replacement CRU if the Service Provider does not receive the defective CRU from you within thirty (30) days of your receipt of the replacement CRU.

**2. On-site Service**

Under On-Site Service, a Service Provider will either repair or exchange the product at your location. You must provide a suitable working area to allow disassembly and reassembly of the product. Some repairs may need to be completed at a service center. If so, the Service Provider will send the product to the service center at its expense.

**3. Courier or Depot Service**

Under Courier or Depot Service, your product will be repaired or exchanged at a designated service center, with shipping at the expense of the Service Provider. You are responsible for disconnecting the product and packing it in a shipping container provided to you to return your product to a designated service center. A courier will pick up your product and deliver it to the designated service center. The service center will return the product to you at its expense.

**4. Customer Carry-in Service**

Under Customer Carry-in Service, your product will be repaired or exchanged after you deliver it to a designated service center at your risk and expense. After the product has been repaired or exchanged, it will be made available to you for return shipping at your risk and expense. If you fail to arrange return shipment, the Service Provider may dispose of the product as it sees fit, with no liability to you.

**5. Mail-In Service**

Under Mail-In Service, your product will be repaired or exchanged at a designated service center after you deliver it at your risk and expense. After the product has been repaired or exchanged, it will be returned to you at Lenovo’s risk and expense, unless the Service Provider specifies otherwise.

**6. Customer Two-Way Mail-In Service**

Under Customer Two-Way Mail-In Service, your product will be repaired or exchanged after you deliver it to a designated service center at your risk and expense. After the product has been repaired or exchanged, it will be made available to you for return shipping at your risk and expense. If you fail to arrange return shipment, the Service Provider may dispose of the product as it sees fit, with no liability to you.

**7. Product Exchange Service**

Under Product Exchange Service, Lenovo will ship a replacement product to your location. You are responsible for its installation and verification of its operation. The replacement product becomes your property in exchange for the failed product, which becomes the property of Lenovo. You must pack the failed product in the shipping carton in which you received the replacement product and return it to Lenovo. Transportation charges, both ways, shall be at Lenovo’s expense. If you fail to use the carton in which the replacement product was received, you may be responsible for any damage to the failed product or to the shipping shipment. You may be charged for the replacement product if Lenovo does not receive the failed product within thirty (30) days of your receipt of the replacement product.

### Les garanties statutaires de conformité et des vices cachés

Cette information complète les informations contenues dans le « Chapitre 2 – Dispositions nationales particulières » de la Garantie Limitée Lenovo (L505-0010-02).

**France**

AUTRES DROITS. LA PRESENTE GARANTIE VOUS CONFÈRE DES DROITS SPÉCIFIQUES. IL EST POSSIBLE QUE VOUS TENIEZ D'AUTRES DROITS, DONT LA NATURE VARIE SELON LA LÉGISLATION QUI VOUS EST APPLICABLE. VOUS POUVEZ ÉGALEMENT DISPOSER D'AUTRES DROITS CONFORMÉMENT À UN ACCORD ÉCRIT AVEC LENOVO. AUCUN ÉLÉMENT DE LA PRÉSENTE GARANTIE N'EFFACE NI SUPPRIME NI LIMITE PAR CONTRAIT. Les garanties statutaires de conformité et des vices cachés se appliquent aux consommateurs. Le consommateur peut, indépendamment de la garantie commerciale éventuellement consentie, mettre en oeuvre la garantie légale de conformité et la garantie contre les défauts cachés.

**Suplemento de Garantía para México**

Este Suplemento de Garantía se considera parte integrante de la Garantía Limitada de Lenovo y será efectivo única y exclusivamente para los productos distribuidos y comercializados dentro del Territorio de los Estados Unidos Mexicanos. En caso de conflicto, se aplicarán los términos de este Suplemento.

El comercializador responsable del producto es Lenovo México S de RL de CV y para efectos de esta garantía en la República Mexicana su domicilio es Paseo de Tamarindos No.400-A Piso 27 Arcos Torre Poniente, Bosques de Las Lomas, Delegación Miguel Hidalgo, C.P. 05120 México, D.F. En el caso de que se precise una reparación cubierta por la garantía o precise de partes, componentes, consumibles o accesorios dirigirse a este domicilio.

Si no existiese ningún Centro de servicio autorizado en su ciudad, población o en un radio de 70 kilómetros de su ciudad o población, la garantía incluirá cualquier gasto de entrega razonable relacionado con el transporte del producto a su Centro de servicio autorizado más cercano. Por favor, llame al Centro de servicio autorizado más cercano para obtener las aprobaciones necesarias o la información relacionada con el envío del producto y la dirección de envío.

Esta garantía ampara todas las piezas de hardware del producto e incluye mano de obra.

El procedimiento para hacer efectiva la garantía consiste en la presentación del producto, acompañado de la póliza correspondiente, debidamente sellada por el establecimiento que lo vendió, o la factura, o recibo o comprobante, en el que constan los datos específicos del producto objeto de la compraventa.

Lenovo sólo puede eximirse de hacer efectiva la garantía en los siguientes casos: a) Cuando el producto se hubiese utilizado en condiciones distintas a las normales. b) Cuando el producto no hubiese sido objeto de acuerdo con el instructivo de uso que se le acompañó. c) Cuando el producto hubiese sido alterado o reparado por personas no autorizadas por el fabricante nacional, importador o comercializador responsable respectivo.

Todos los programas de software precargados en el equipo sólo tendrán una garantía de noventa (90) días por defectos de instalación desde la fecha de compra. Lenovo no es responsable de la información incluida en dichos programas de software y/o de cualquier programa de software adicional instalado por Usted o instalado después de la compra del producto.

La garantía cubre la atención, revisión y corrección de errores, defectos o inconsistencias que impidan el desempeño normal de un equipo de cómputo en cuanto a su hardware y software. Los servicios no cubiertos por la garantía se cargarán al usuario final, previa obtención de una autorización. Esta garantía tiene una duración de un año a partir del momento de la compra e incluye la mano de obra, por lo que en caso de aplicarse la garantía, esta no causará ningún gasto o costo para el cliente.

Centros de Servicios autorizados para hacer efectiva la garantía:

- Lenovo México con domicilio en Paseo de Tamarindos No.400-A Piso 27 Arcos, Torre Poniente, Bosques de Las Lomas, Delegación Miguel Hidalgo, C.P. 05120 México, D.F. Teléfono 01800-083-4916, [http://support.lenovo.com/es\\_mx/product-service/service-provider/default.page](http://support.lenovo.com/es_mx/product-service/service-provider/default.page)

- Lenovo Monterrey con domicilio en Boulevard Escobedo No.316, Apodaca Technology Park, Apodaca, C.P. 66601, Nuevo León, México. Teléfono 01800-083-4916, [http://support.lenovo.com/es\\_mx/product-service/service-provider/default.page](http://support.lenovo.com/es_mx/product-service/service-provider/default.page)

**Importado por:**

**Lenovo México S. de R.L. de C.V.**

**Av. Santa Fe 505, Piso 15**

**Col. Cruz Manca**

**Cuajimalpa, D.F., México**

**C.P. 05349**

**Tel. (55) 5000 8500**

### Lenovo Limited Warranty - Customer Notice

Read the Lenovo Limited Warranty (LLW) at [http://www.lenovo.com/warranty/llw\\_02](http://www.lenovo.com/warranty/llw_02). If you cannot view the LLW, contact your local Lenovo office or reseller to obtain a printed version of the LLW.

Warranty information applicable to your machine:

- Warranty Period: 1 year
- Type of Warranty Service: Customer Replaceable Unit (CRU) and Customer Carry-in
- Lenovo Limited Warranty Version: L505-0010-02 08/2011

For warranty service, consult the telephone list at <http://www.lenovo.com/support/phone>. Phone numbers are subject to change without notice.

**Garantia Limitada da Lenovo - Aviso ao Cliente**

Leia a Garantia Limitada Lenovo (LLW) em: [http://www.lenovo.com/warranty/llw\\_02](http://www.lenovo.com/warranty/llw_02). Se não seja possível exibir a LLW, entre em contato com o escritório ou revendedor Lenovo local para obter uma versão impressa da LLW.

Informações de garantia aplicáveis à sua máquina:

- Período de Garantia: 1 ano
- Tipo de Serviço de Garantia: Unidade Substituível pelo Cliente (CRU) e Serviço de Transporte pelo Cliente
- Versão da Garantia Limitada Lenovo: L505-0010-02 08/2011

Para obter informações sobre o serviço de garantia, consulte a lista de telefones em <http://www.lenovo.com/support/phone>. Os números de telefone estão sujeitos a alterações sem aviso prévio.

**Lenovo Ograničena garancija – Zabeležka za klijenta**

Pročitajte Ograničenu garanciju na Lenovo (LLW) na adres [http://www.lenovo.com/warranty/llw\\_02](http://www.lenovo.com/warranty/llw_02). Ako ne možete doći do LLW, svrgnete se s mestim adres ili rizeršer na Lenovo, za da polučite pečat Lenovo na LLW, kontaktirajte vašeg prodavca.

Informacje gwarancyjne mające zastosowanie do Maszyny Klienta:

- Okres gwarancyjny: 1 rok
- Typ serwisu gwarancyjnego: Serwis polegający na dostarczeniu Części Wymienialnych przez Klienta (Customer Replaceable Unit - CRU) oraz serwis z transportem przez Klienta.
- Wersja ograniczonej gwarancji Lenovo: L505-0010-02 08/2011.

Lista telefonów do osób odpowiedzialnych za serwis gwarancyjny znajduje się w serwisie: <http://www.lenovo.com/support/phone>. Numery telefonów mogą ulec zmianie bez powiadomienia.

**Garantia Limitada da Lenovo - Aviso ao Cliente**

Leia a Garantia Limitada da Lenovo (LLW, Lenovo Limited Warranty) disponível em [http://www.lenovo.com/warranty/llw\\_02](http://www.lenovo.com/warranty/llw_02). Se não conseguir visualizar a LLW, contate o seu representante ou revendedor local da Lenovo para obter uma versão impressa da LLW.

Informações de garantia aplicáveis à sua máquina:

- Período de Garantia: 1 ano
- Tipo de Serviço de Garantia: Serviço de Unidades Substituíveis pelo Cliente (CRU) e Serviço de Entrega
- Garantia Limitada Lenovo Versão: L505-0010-02 08/2011

Para contactar o serviço de garantia, consulte a lista telefónica em <http://www.lenovo.com/support/phone>. Os números de telefone indicados estão sujeitos a alteração sem aviso prévio.

**Observacje pentru client - Garantía limitată Lenovo**

Vă rugăm să citiți Garanția limitată Lenovo (GLL) la Web-strаницe [http://www.lenovo.com/warranty/llw\\_02](http://www.lenovo.com/warranty/llw_02). Dacă nu puteți vizualiza GLL, contactați reprezentanța locală Lenovo sau reseller-ul pentru a obține grațuit o versiune imprimată a LLW.

Informații referitoare la garanție aplicabile unității dumneavoastră:

- Perioada de garanție: 1 an
- Tip de serviciu garanție: Customer Replaceable Unit (CRU) și Customer Carry-in
- Versiunea Garanție limitată Lenovo: L505-0010-02 08/2011

Pentru service-ul în garanție, consultați lista de telefoane la <http://www.lenovo.com/support/phone>. Numerele de telefon pot fi modificate fără preaviz.

**Ограниченная гарантия Lenovo – Замечания для заказчиков**

Ознакомьтесь с Ограниченной гарантией Lenovo (Lenovo Limited Warranty – LLW) на Web-странице [http://www.lenovo.com/warranty/llw\\_02](http://www.lenovo.com/warranty/llw_02). Если вы не можете просмотреть LLW, то распечатанную версию LLW можно получить в местном представительстве Lenovo или у вашего дилера.

Informația o garanții la vašego kompjutera:

- Гарантійний строк: 1 рік
- Тип гарантійного обслуговування: обслуговування при отказе узлов, підлежачих заміні силами заказчика (CRU), і обслуговування при доставці силами заказчика
- Версія Ограниченої гарантії Lenovo L505-0010-02 08/2011

За гарантійним обслуговуванням обращайтесь по телефону, приведенем на Web-странице <http://www.lenovo.com/support/phone>. Номера телефонів можуть бути змінені без уведомления.

**Lenovo ograničena garancija – obavještenje za kupce**

Pročitajte Lenovo ograničenu garanciju (LLW) na adresi [http://www.lenovo.com/warranty/llw\\_02](http://www.lenovo.com/warranty/llw_02). Ukoliko niste u mogućnosti da pogledate Lenovo ograničenu garanciju, obratite se lokalnom predstavništvu kompanije Lenovo ili distributeru da biste dobili štampanu verziju Lenovo ograničene garancije.

Informacije o garanciji koje se odnose na vašu mašinu:

- Garantni period: 1 godina
- Vrsta usluge garancije: korisnički zamjenjiva jedinica (CRU) i usluga servisiranja ličnom dostavom
- Versija Lenovo ograničene garancije: L505-0010-02 08/2011

Za uslugu garancije, pogledajte spisak telefonskih brojeva na web lokaciji: <http://www.lenovo.com/support/phone>. Telefonski brojevi se mogu menjati bez prethodnog obavještenja.

**Obmedzená záruka spoločnosti Lenovo – Vyhlasenie pre zákazníkov**

Prečítajte si obmedzenú záruku spoločnosti Lenovo (LLW) na adrese [http://www.lenovo.com/warranty/llw\\_02](http://www.lenovo.com/warranty/llw_02). Ak záruku LLW neviete zobraziť, kontaktujte miestne zastúpenie spoločnosti Lenovo alebo jej predajcu a požiadajte o tlačiu verziu záruky LLW.

Záručné informácie týkajúce sa vášho počítača:

- Záručná lehota: 1 rok
- Typ záručného servisu: Servis dielcov vymeniteľných zákazníkom (dielcov CRU) a služba doručenia zákazníkom
- Versia obmedzenej záruky Lenovo: L505-0010-02 08/2011

V prípade záujmu o záručný servis volajte na číslo uvedené v telefónnom zozname na adrese <http://www.lenovo.com/support/phone>. Telefónne čísla môžu byť zmenené bez predchádzajúcnho upozomenia.

**Lenovova omejena garancija – obavestilo za stranke**

Omejeno garancijo Lenovo (LLW) si lahko preberete na naslovu [http://www.lenovo.com/warranty/llw\\_02](http://www.lenovo.com/warranty/llw_02). Če si ne morete ogledati omejene garancije Lenovo (LLW), se obrnite na lokalno pisarno Lenovo ali prodajalca, kjer boste dobili natisnjeno različico.

Garancijske informacije, ki veljajo za vaš računalnik:

- Garancijsko obdobje: 1 leto
- Vrsta garancijskega servisa: nadomestni del, ki ga lahko zamenja stranka (CRU), in osebna dostava na servis
- Različica omejene garancije Lenovo: L505-0010-02 08/2011

Vzviš z garancijo za storitve je na naslovu <http://www.lenovo.com/support/phone> na voljo seznam telefonskih števil. Če si ne morete ogledati omejene garancije, se obrnite na lokalno predstavništvo ali prodajalca sprememb telefonskih števil brez predhodnega obvestila.

**Garantía Limitada de Lenovo - Aviso para el cliente**

Lea la Garantía limitada de Lenovo (LLW) en [http://www.lenovo.com/warranty/llw\\_02](http://www.lenovo.com/warranty/llw_02). Si no puede ver la LLW, comuníquese con la oficina local de Lenovo o el revendedor para obtener una versión impresa de LLW.

Información de la garantía aplicable a su equipo:

- Período de garantía: 1 año
- Tipo de servicio de garantía: Unidad reemplazable por el cliente (CRU) y servicios centralizados
- Versión de la garantía limitada de Lenovo: L505-0010-02 08/2011

Para conocer el servicio de garantía, consulte la lista de teléfonos en <http://www.lenovo.com/support/phone>. Estos números de teléfono están sujetos a cambio sin previo aviso.

**Kundrevör om Lenovo Begränsad Garanti**

Läs Lenovos begränsade garanti (LLW) på [http://www.lenovo.com/warranty/llw\\_02](http://www.lenovo.com/warranty/llw_02). Om du inte kan visa LLW-garantitexten kan du kontakta ditt lokala Lenovo-kontor eller

3. Lenovo Begränsetz Herstellergarantie: L505-0010-02 08/2011

Um Garanteservice in Anspruch zu nehmen, rufen Sie die entsprechende Telefonnummer aus der Liste unter der folgenden Adresse an: <http://www.lenovo.com/support/phone>. Telefonnummern können jederzeit ohne Vorankündigung geändert werden.

**Lenovo Korlátoltzott Jótállás – Vásárlói közlemény**

Olvassa el a Lenovo Korlátoltzott Jótállás (LLW) részleteit a [http://www.lenovo.com/warranty/llw\\_02](http://www.lenovo.com/warranty/llw_02) címen. Ha nem tudja megtekinteni a Lenovo Korlátoltzott Jótállást, akkor lépjen kapcsolatba a Lenovo helyi képviselőivel vagy vizionálójával, és kérje a Lenovo Korlátoltzott Jótállás nyomtatott példányát.

A számítógépére vonatkozó jótállási információk:

- Jótállási időszak: 1 év
- Jótállási szolgáltatás típusa: Vásárlói által cserélhető egység (CRU) és Beszállítós szolgálat
- Lenovo Korlátoltzott Jótállás verziója: L505-0010-02 08/2011

A jótállási szolgáltatás elérhetőségével kapcsolatban tekintse meg a telefonos zárt listáját <http://www.lenovo.com/support/phone> címen. A telefonszámok bejelentés nélkül megváltozhatnak.

**Garanzia limitata Lenovo (LLW) - Avviso per il cliente**

Leggere la dichiarazione di Garanzia limitata Lenovo (LLW, Lenovo Limited Warranty) all'indirizzo [http://www.lenovo.com/warranty/llw\\_02](http://www.lenovo.com/warranty/llw_02). Se non è possibile visualizzare la dichiarazione LLW, contattare l'ufficio locale Lenovo o il rivenditore per ottenerne una versione stampata.

Informazioni sulla garanzia applicabili alla propria macchina:

- Periodo di garanzia: 1 anno
- Tipo di servizio di garanzia: Customer Replaceable Unit (CRU) e Customer Carry-in
- Versione di garanzia limitata Lenovo: L505-0010-02 08/2011

Per il servizio di garanzia, consultare l'elenco dei numeri telefonici all'indirizzo <http://www.lenovo.com/support/phone>. I numeri di telefono sono soggetti a modifiche senza preavviso.

**Lenovo Beperkte Garantie - Kennisgeving aan klant**

Lees de Lenovo Beperkte Garantie (LLW) op [http://www.lenovo.com/warranty/llw\\_02](http://www.lenovo.com/warranty/llw_02). Als u de LLW niet kunt weergeven, neem dan contact op met uw plaatselijke Lenovo-kantoor / -dealer om een gedrukte versie van de LLW te verkrijgen.

Garantie-informatie die van toepassing is op uw machine:

- Garantieperiode: 1 jaar
- Type garantieservice: Customer Replaceable Unit (CRU) en Customer Carry-in
- Versie Lenovo Beperkte Garantie: L505-0010-02 08/2011

Raadpleeg voor garantieservice de telefoonlijst op <http://www.lenovo.com/support/phone>. Telefoonnummers kunnen zonder voorafgaande kennisgeving worden gewijzigd.

**Lenovos garantieltiingelser - Merknad til kunden**

Læs Lenovos garantieltiingelser (LLW) på [http://www.lenovo.com/warranty/llw\\_02](http://www.lenovo.com/warranty/llw_02). Hvis du ikke kan vise garantieltiingelsen, må du kontakte ditt lokale Lenovo-kontor eller forhandleren for å få en trykt versjon.

Garantiinformasjon som gjelder din maskin:

- Garantieperiode: 1 år
- Type garantiservice: CRU (Customer Replaceable Unit) og innlevering av kunden
- Lenovos garantieltiingelser versjon: L505-0010-02 08/2011

Hvis du har spørsmål om garantiservice, se telefonlisten på <http://www.lenovo.com/support/phone>. Telefonnumrene kan bli endret uten forvarsel.

**Organizacija gwarancja Lenovo - informacja dla Klienta**

Prosimy o przeczytanie ograniczonej gwarancji Lenovo (Lenovo Limited Warranty – LLW) pod adresem: [http://www.lenovo.com/warranty/llw\\_02](http://www.lenovo.com/warranty/llw_02). Jeśli nie można wyświetlić LLW, należy skontaktować się z miejscowym biurem Lenovo lub z rezersem w celu uzyskania wersji drukowanej.

Informacje gwarancyjne mające zastosowanie do Maszyny Klienta:

- Okres gwarancyjny: 1 rok
- Typ serwisu gwarancyjnego: Serwis polegający na dostarczeniu Części Wymienialnych przez Klienta (Customer Replaceable Unit - CRU) oraz serwis z transportem przez Klienta.
- Wersja ograniczonej gwarancji Lenovo: L505-0010-02 08/2011.

Lista telefonów do osób odpowiedzialnych za serwis gwarancyjny znajduje się w serwisie: <http://www.lenovo.com/support/phone>. Numery telefonów mogą ulec zmianie bez powiadomienia.

**Garantia Limitada da Lenovo - Aviso ao Cliente**

Leia a Garantia Limitada da Lenovo (LLW, Lenovo Limited Warranty) disponível em [http://www.lenovo.com/warranty/llw\\_02](http://www.lenovo.com/warranty/llw_02). Se não conseguir visualizar a LLW, contate o seu representante ou revendedor local da Lenovo para obter uma versão impressa da LLW.

Informações de garantia aplicáveis à sua máquina: