

FANATEC®

ClubSport Universal Hub V2



EN Quick Guide
FR Guide De Démarrage Rapide
DE Kurzanleitung
ES Guía Rápida
IT Guida Rapida
PT Guia Rápido

Rev. 08

[Video Manual](#)

VIDEO MANUAL

[Fanatec.com/QR/CS-UH-V2](https://fanatec.com/QR/CS-UH-V2)

[Driver Download](#)

[Fanatec.com/driver](https://fanatec.com/driver)

[Driver & Firmware Instruction Manual](#)

[Fanatec.com/df-manual-V1](https://fanatec.com/df-manual-V1)

[Windows PC](#)

[PC Mode](#)

[Update Firmware](#)

H EN Modes - Page 8; DE Modi - Seite 8; FR Modes - Page 8
 ES Modos - Página 8; IT Modalità - Pagina 8; PT Modos - Página 8

EN Translations - Page 12; DE Übersetzungen - Seite 12; FR Traductions - Page 12;
 ES Traducciones - Página 12; IT Traduzioni - Pagina 12; PT Traduções - Página 12

A PACKAGE CONTENT

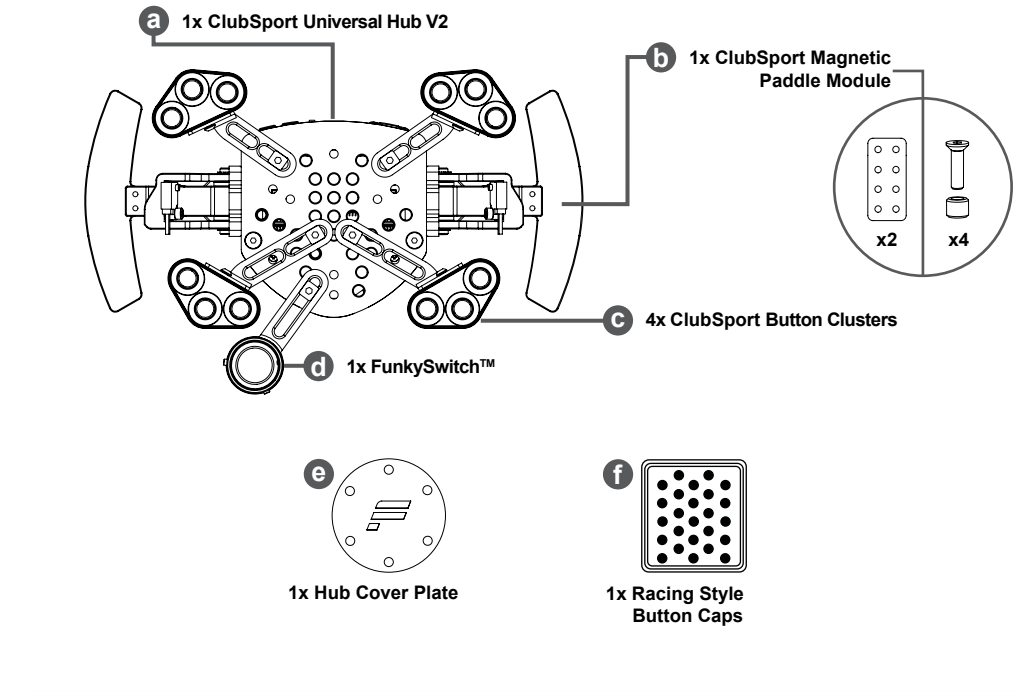

⚙️		⚙️	
	1x ∅ 4 mm	B1	5x - M5 x 11 mm
	1x ∅ 3 mm	B2	6x - M5 x 16 mm
	1x ∅ 2.5 mm	B3	6x - M5 x 16 mm
	1x ∅ 2 mm	B4	4x - M5 x 12 mm
	1x ∅ 8 mm	N1	5x - M5 x 7.8 mm x 4.7 mm
		W1	4x - 13.5 mm x 2.5 mm
		W2	4x - M5 x 8.0 mm x 0.8 mm

* EN Not included; DE Nicht enthalten; FR Non inclus; ES No incluido; IT Non incluso; PT Não incluso

B QUICK RELEASE ATTACHMENT

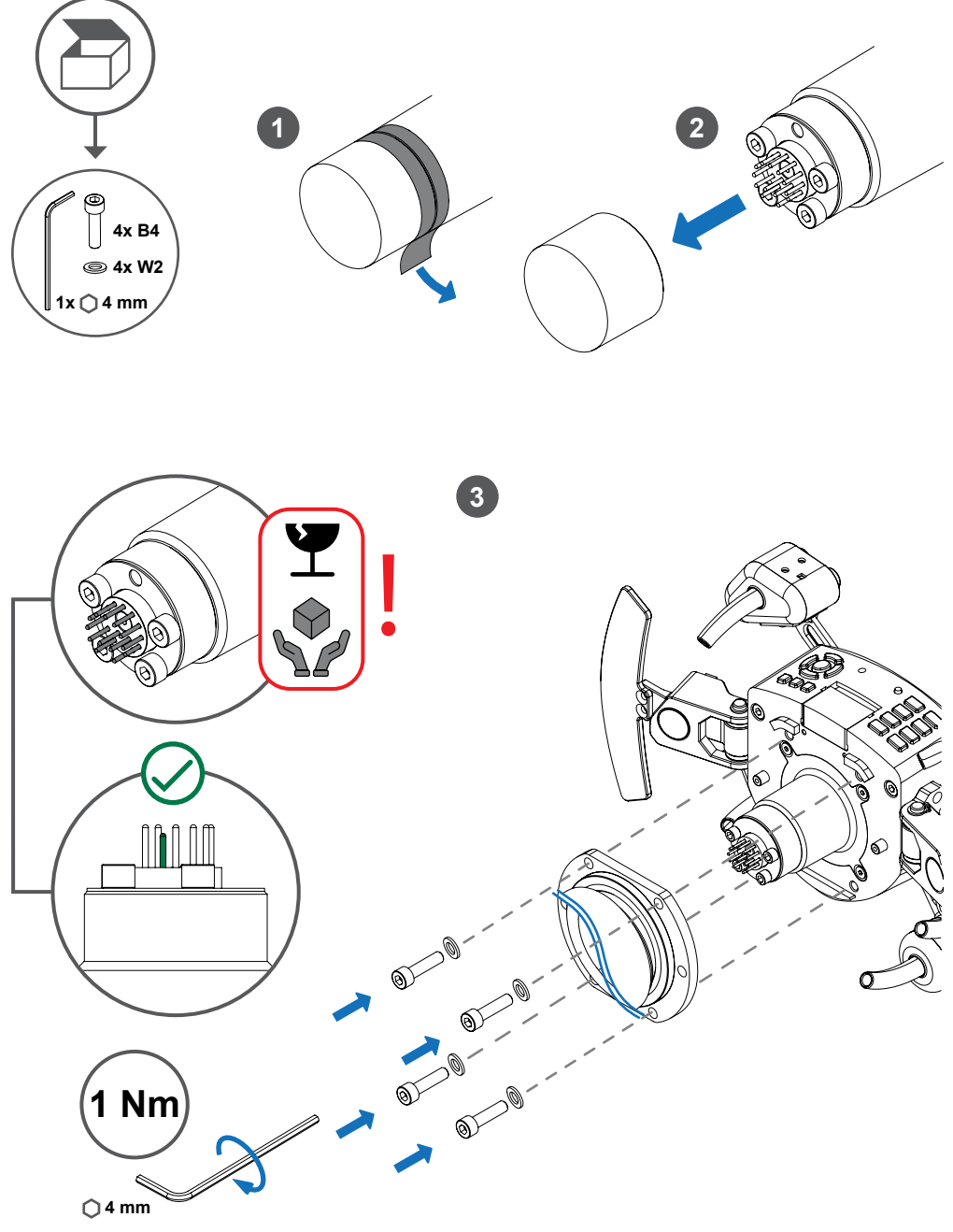

C CLUBSPORT BUTTON CLUSTER ADJUSTMENT

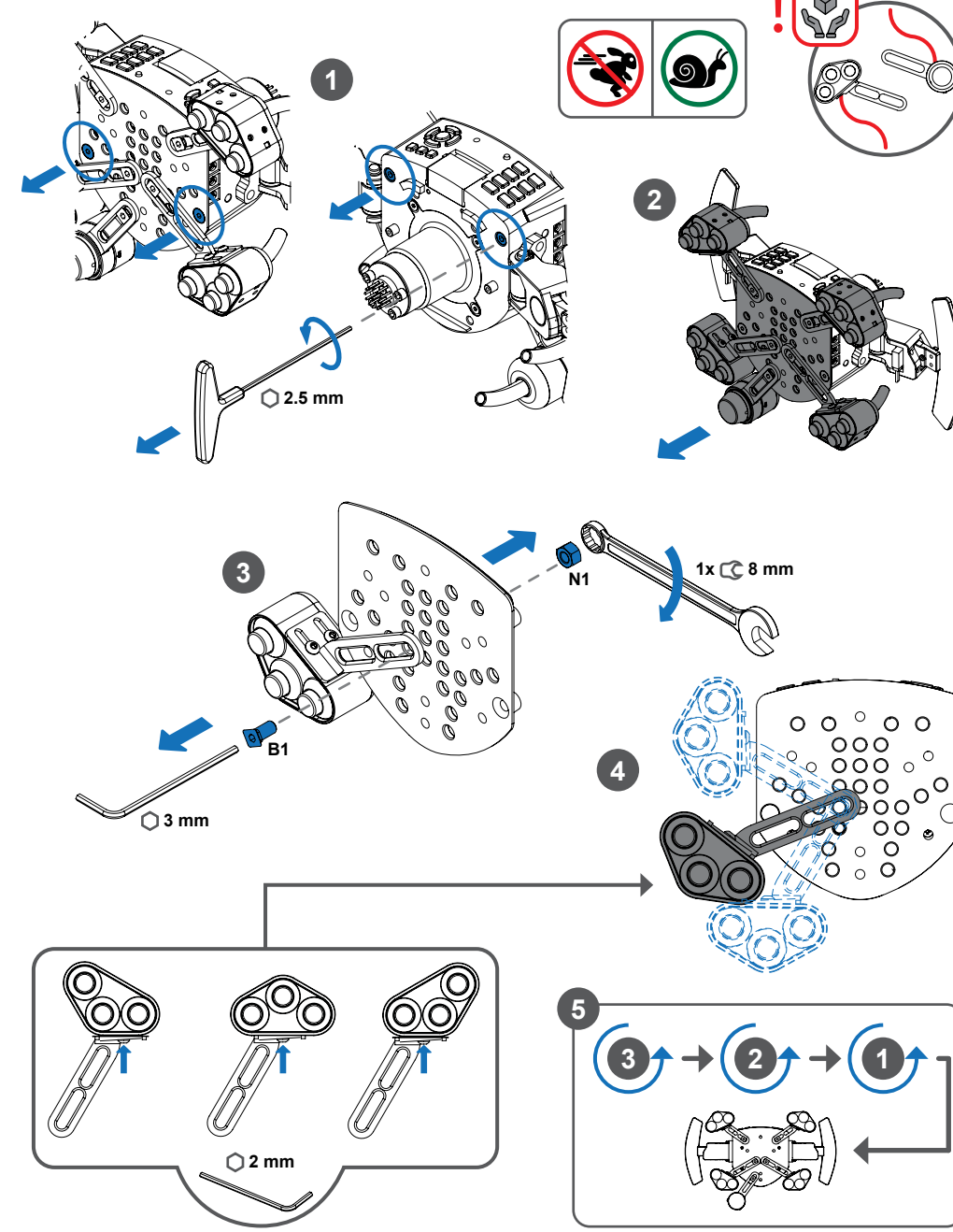

D CONNECTIONS

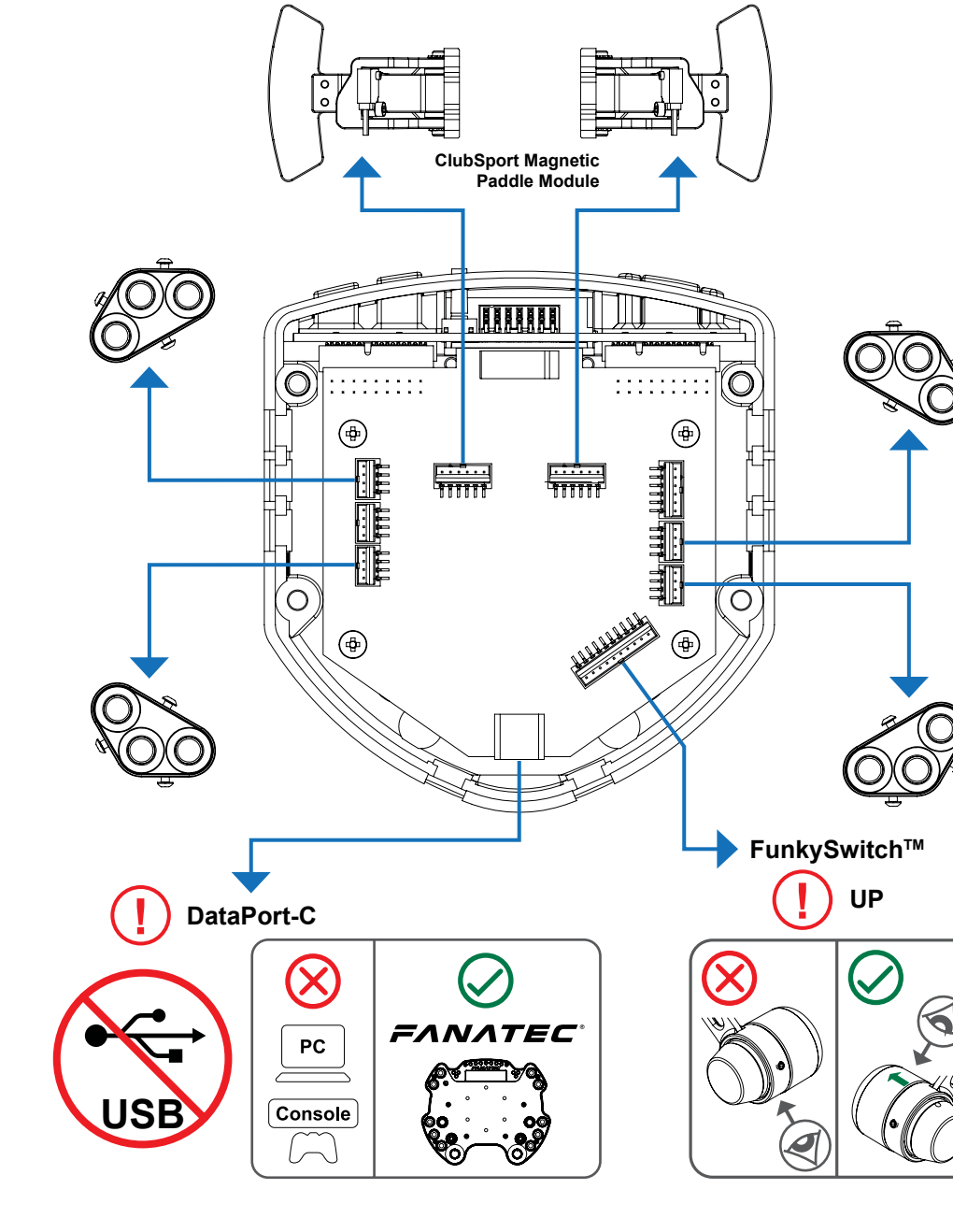

E RIM ATTACHMENT

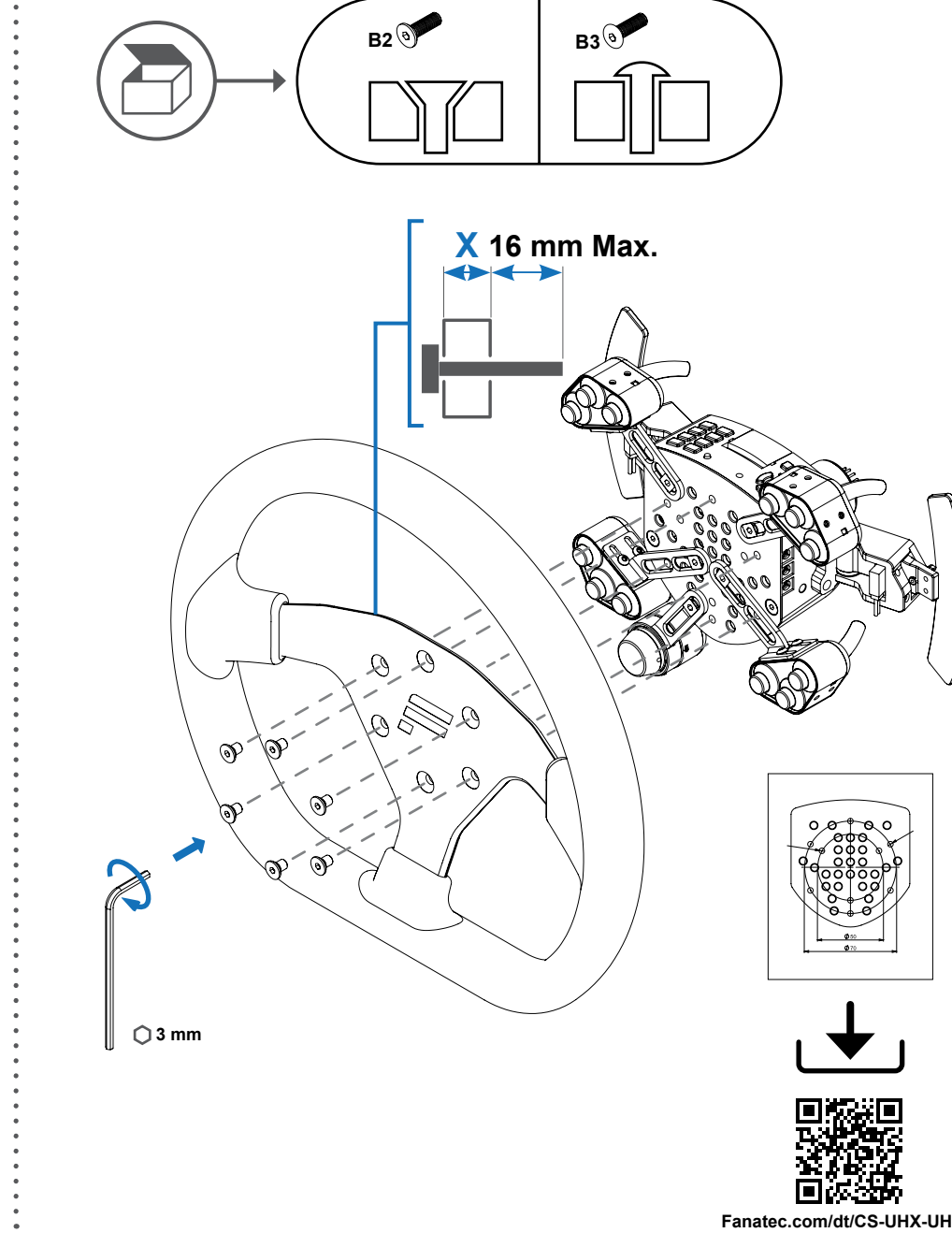

Fanatec.com/dt/CS-UHX-UH-V2

F CENTRE CALIBRATION

1. Press the center calibration button on the steering wheel.
2. Enter Tuning Menu.
3. Turn the steering wheel to the right.
4. Turn the steering wheel to the left.
5. Exit Tuning Menu.

G SHIFTER CALIBRATION

1. Press the shifter calibration button on the gear shifter.
2. Press the center calibration button on the steering wheel.
3. Press the shifter calibration button on the gear shifter.
4. Press the center calibration button on the steering wheel.
5. Press the shifter calibration button on the gear shifter.
6. Perform for all gears.

* EN Sold separately; DE Separat erhältlich; FR Vendu séparément; ES Se vende por separado; IT Venduto separatamente; PT Vendido separadamente

H MODES

EN Repeat
DE Wiederholen
FR Répéter
ES Repetir
IT Ripetere
PT Repetir

* EN Wheel Base Dependent
DE Je Nach Wheel Base
FR Dépendant de la base du volant
ES Dependiente de la Base del Volante
IT Dipendente dalla base del volante
PT Dependente da base do volante

Fanatec.com/manuals

I TUNING OPTIONS

1. Enter Tuning Menu.
2. Navigate.
3. Exit Tuning Menu.

Fanatec.com/manuals

J CLUBSPORT MAGNETIC PADDLE MODULE ADJUSTMENT

1. Remove the paddle module from the steering wheel.
2. Adjust the paddle module.
3. Reinstall the paddle module.

4 mm

K DISPLAY ADJUSTMENT

1. Press the display adjustment button.
2. Adjust the display.

L BUTTON MAPPING

#	PC	PlayStation®
1	2	X
2	3	O
3	4	△
4	1	□
5	10	≡
6	9	↖/↗
7	11	R3
8	12	L3
9	7	R2
10	8	L2
11	5	R1
12	6	L1
13	↔, ↕, ↔, ↕	↔, ↕, ↔, ↕

FANATEC

Tuning Button

M SUPPORT

Fanatec.com/app

Fanatec.com/support/faq

VIDEO MANUAL
Fanatec.com/QR/CS-UH-V2

Button Group 1			Button Group 2		
#	PC	PlayStation®	#	PC	PlayStation®
10	8	L2	7	11	R3
12	6	L1	11	5	R1
8	12	L3	9	7	R2

Paddle Shift Left			Paddle Shift Right		
#	PC	PlayStation®	#	PC	PlayStation®
12	6	L1	11	5	R1

Button Group 3			Button Group 4		
#	PC	PlayStation®	#	PC	PlayStation®
6	9	↖/↗	2	3	O
4	1	□	1	2	X
3	4	△	5	10	≡

FunkySwitch™		
#	PC	PlayStation®
14	↔, ↕, ↔, ↕	↔, ↕, ↔, ↕
FunkySwitch™	↻ 25 / ↻ 24	↻ GSB 1 / ↻ GSB 2

* GSB = Game-Specific Button

N WARRANTY

EN The product warranty is provided by Endor AG. Refer to the included warranty sheet as well as the terms & conditions of Endor AG on fanatec.com.

DE Dieses Produkt unterliegt der Garantie der Endor AG. Beachten Sie die beiliegenden Garantieblätter sowie die Allgemeinen Geschäftsbedingungen der Endor AG auf fanatec.com.

FR Ce produit est sous la garantie d'Endor AG. Reportez-vous aux fiches de garantie incluses ainsi qu'aux conditions générales d'Endor AG sur fanatec.com.

ES Este producto está bajo garantía de Endor AG. Consulte las hojas de garantía incluidas, así como los términos y condiciones de Endor AG en fanatec.com.

IT Questo prodotto è coperto dalla garanzia di Endor AG. Fare riferimento ai fogli di garanzia inclusi nonché ai termini e condizioni di Endor AG su fanatec.com.

PT Este produto está sob garantia da Endor AG. Consulte as folhas de garantia incluídas, bem como os termos e condições da Endor AG em fanatec.com.

CE UK CA FC EAC REACH

This device complies with part 15 of the FCC rules. The operation of this device is subject to the following two conditions:

- This device may not cause harmful interference, and must accept any interference received, including interference that may cause undesired operation.
- This device was not modified differently than described explicitly in this user manual.

NOTE: This device was tested and approved to the limitations for class B of digital devices according to part 15 of the FCC rules. This limitation should ensure an adequate protection against harmful interferences in residential areas. However, a warranty for the non-recurring of interferences is not assumed.

Do not modify the device differently than explicitly described in the product-related user manual. Nevertheless, if you do modify the device differently than explicitly described in the product-related manual, you can be determined to stop the operation of the device.

Imported by Endor America LLC
8200 Wilshire Blvd. Suite 200 - Beverly Hills CA 90211 - USA
Telephone: tel: +1 321-655-3524
Email: info.webshop@fanatec.com
Website: www.fanatec.com - www.endor.ag

ENDOR products comply with the European Union Directive 2011/65/EU and its amendments, including exemptions for the use of lead such as high-temperature solder. ENDOR is working to phase out the use of these exempted substances where technically possible.

Manufactured and distributed by
ENDOR
Fanatec is a registered trademark of Endor AG
Designed and developed by Endor AG in Germany

E.ON-Allee 3 - 84036 Landshut - Germany
Telephone: +49 (871) 9221-122 Fax: +49 (871) 9221-122
Email: info.webshop@fanatec.com
Website: www.fanatec.com - www.endor.ag
Made in China

Contact | 33333333
Endor AG
E.ON-Allee 3 - 84036 Landshut - Germany
Telephone | Телефон: +49 (871) 9221-122
Email | Електронна пошта: info.webshop@fanatec.com

This product meets the requirements of the Technical Regulations which limit the use of certain hazardous substances in electrical and electronic equipment.

Цей продукт відповідає вимогам RoHS (Директива ЄС 2011/65 / ЄС)