



**SIEMENS**  
*Ingenuity for life*



**Siemens Digital Industries Webinari**  
**FA5: SIMATIC Safety**

## Današnji predavač

**SIEMENS**  
*Ingenuity for life*



### Darko Živković

#### Responsibility

Sales Engineer  
Factory Automation – PLC, HMI, etc.  
Focus: OEM, Motion Control  
Sitrain training centre manager

#### Contact

✉ [darko.zivkovic@siemens.com](mailto:darko.zivkovic@siemens.com)  
🏭 RC-RS DI FA  
🏠 Belgrade, Serbia

## Siemens Digital Industries Webinari, Novembar 2020.



**Datum**

**Tema**

**Predavač**

03.11.2020.

DI1: Industry Mall & Online software delivery

*Mirko Milovanović*

10.11.2020.

FA5: SIMATIC Safety

*Darko Živković*

17.11.2020.

FA6: SIMATIC IPC

*Tamara Lazić*

24.11.2020.

FA7: SIMATIC IOT

*Zoran Jovanović*

## Siemens Digital Industries: Webinari iz prvog ciklusa



Materijal dostupan na web stranici:

<https://new.siemens.com/rs/sr/kompanija/fairs-events/di-webinari.html>

FA1: Motion Control	PI1: PI Academy world
FA2: Energy Management System	PI2: PI workshop for specialist
FA3: Redundantni kontroleri serije S7-1500R/H	PI3: #New@PI
FA4: WinCC Unified	AE1: Digitalna rešenja u procesnoj industriji
MC1: DT konfigurator	CP1: Control Panel Online Symposium
MC2: Sizer, large drives	CP2: Clever engineering in the control panel
MC3: Sizer, motion drives	CP3: New series of signaling devices 3SU
CI1: Industrial Networks	CP4: SIRIUS 3RW Soft starters
	DE1: Siemens Digital Enterprise



# SIMATIC Safety

Beograd 10.11.2020.

# Agenda



- 1 **System overview**
- 2 S7-1500 Controller
- 3 ET 200
- 4 Module evaluation and addressing
- 5 Application samples and tools

# How can a user satisfy functional safety requirements? Through the use of an additional system?

**SIEMENS**  
*Ingenuity for life*

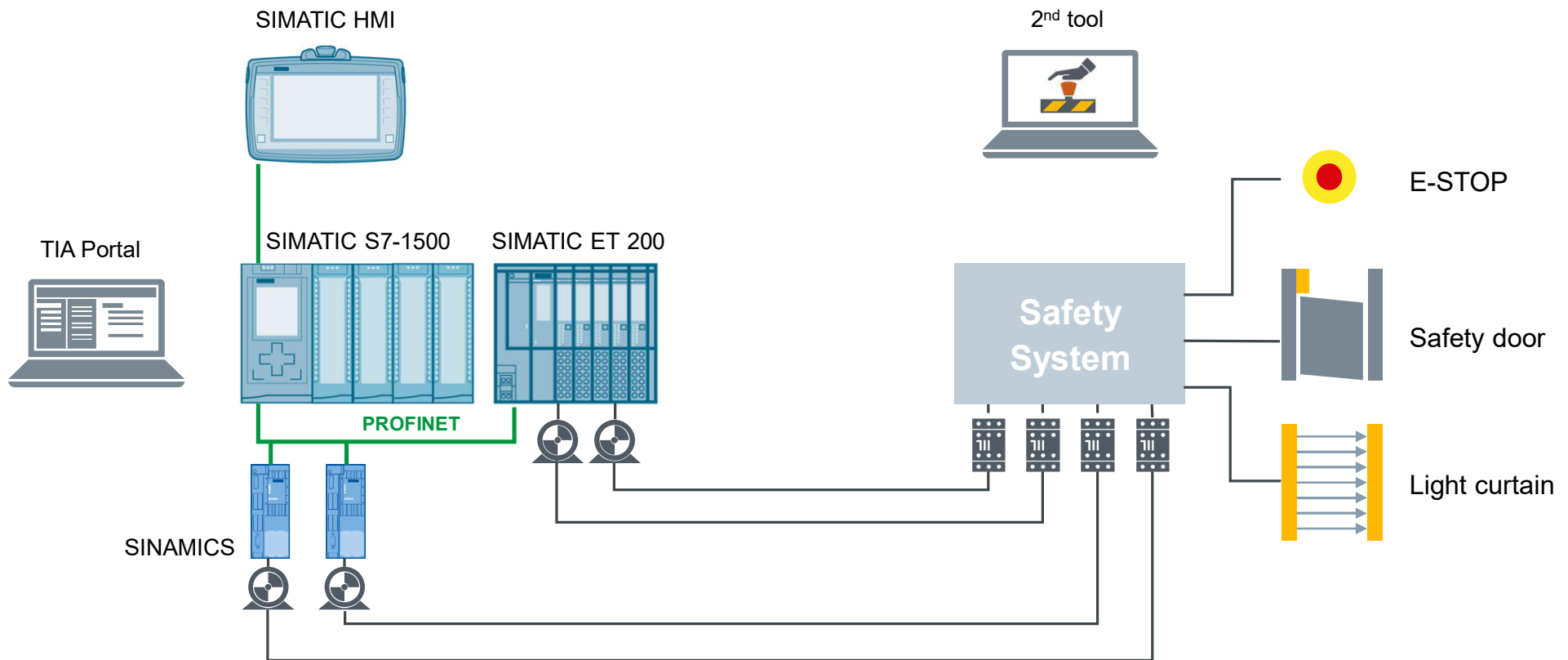

# How can a user satisfy functional safety requirements? What are the advantages of SIMATIC Safety Integrated?

**SIEMENS**  
*Ingenuity for life*

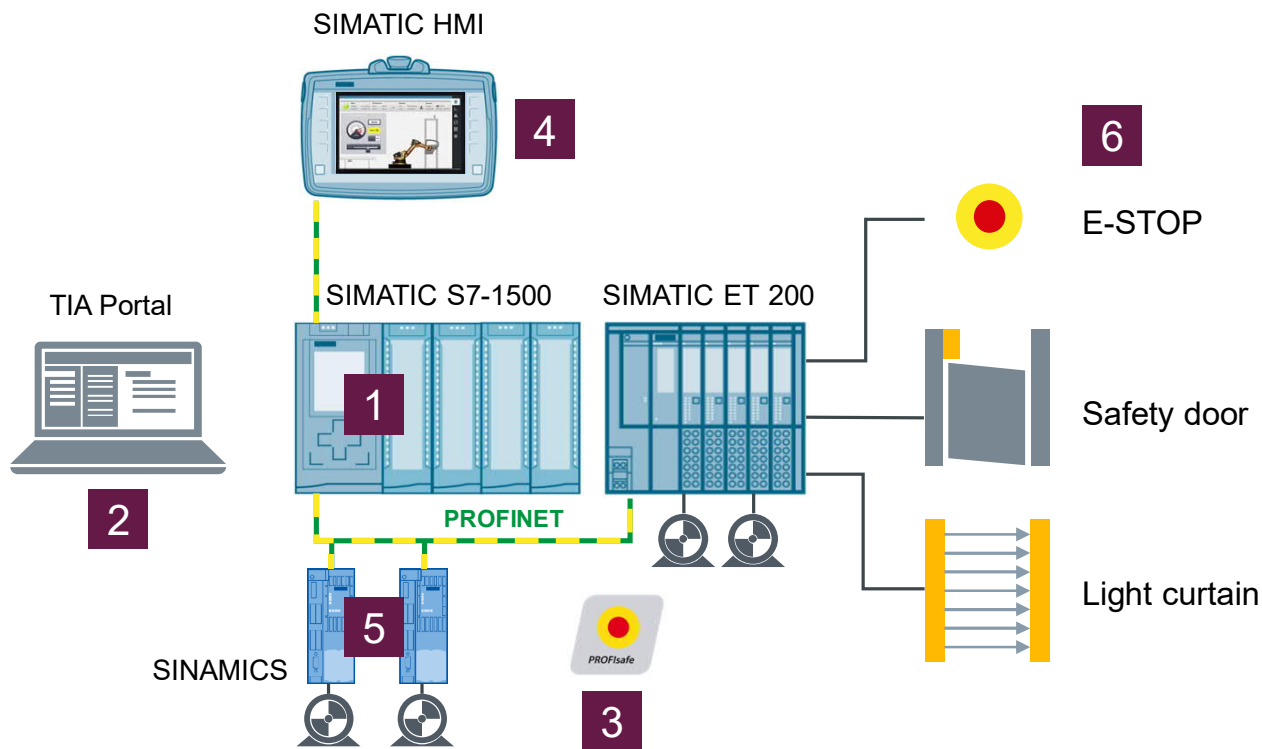

- 1 One controller
- 2 One engineering
- 3 One network
- 4 Powerful diagnostics
- 5 SINAMICS Integrated safety functions
- 6 Flexibility

# Second generation of SIMATIC Safety – SIMATIC Safety in the TIA Portal

**SIEMENS**  
*Ingenuity for life*

## Fail-safe engineering

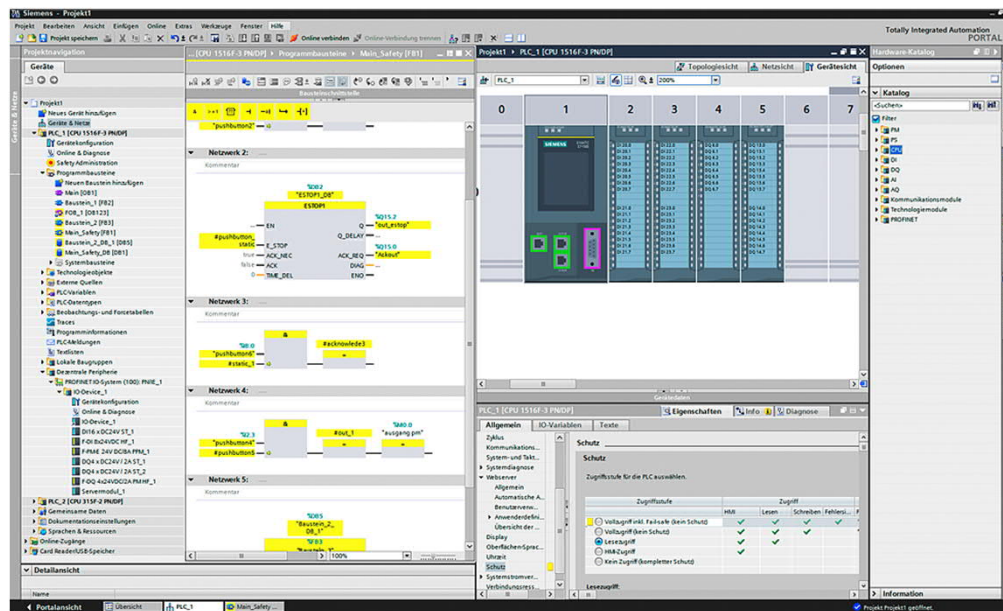

## STEP 7 Safety Basic and Advanced

## Fail-safe controller



SIMATIC S7-1500



## Fail-safe I/O

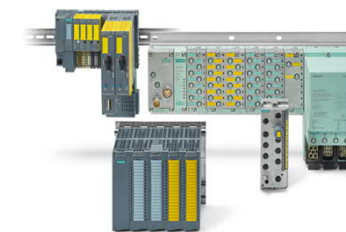

SIMATIC ET 200

# Agenda

- 1 System overview
- 2 **S7-1500 Controller**
  - 2.1 Overview
  - 2.2 Access protection
  - 2.3 Webserver
  - 2.4 Onboard display
- 3 ET 200
- 4 Module evaluation and addressing
- 5 Application samples and tools

# Agenda

- 1 System overview
- 2 S7-1500 Controller
  - 2.1 **Overview**
  - 2.2 Access protection
  - 2.3 Webserver
  - 2.4 Onboard display
- 3 ET 200
- 4 Module evaluation and addressing
- 5 Application samples and tools

# SIMATIC S7-1500 with Safety Integrated – Setup of a safety system

## Safety system

Detection



Evaluation



Response



Recording an event  
(process or human command)

F-DI

- Reads in the switching signal
- Safety-related sensor diagnostics
- Provides the input signal via process image

F-CPU

- Logical linking of safety functions
- Provides the output signal via process image

F-DQ

- Switching the control circuit
- Safety-related diagnostics of the output channel and of the actuator

Switching off the power unit  
of the drive

### Note

Evaluation of the safety system with Siemens

**Safety Evaluation Tool (SET)** →



## SIMATIC S7-1500 with Safety – Integrated coded processing

**SIEMENS**  
*Ingenuity for life*

### Classical principle of an F-controller: Structural redundancy (HFT)

- Two (or more) identical controllers
- All are executing the same program
- Results are compared



e.g. S5-95F

### Principle of Safety Advanced F-controllers: Coded processing

- Generates a coded user F-program via the F-Compiler (diversity)
- Sequential program processing uncoded and coded (time redundancy)
- Results are compared



e.g. S7-1500

Implementation of fail-safety on a CPU (an individual processor with self-tests)

# The SIMATIC Controller portfolio always provides the right controller - Plus integrated added value!

**SIEMENS**  
*Ingenuity for life*

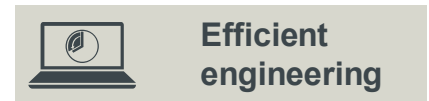
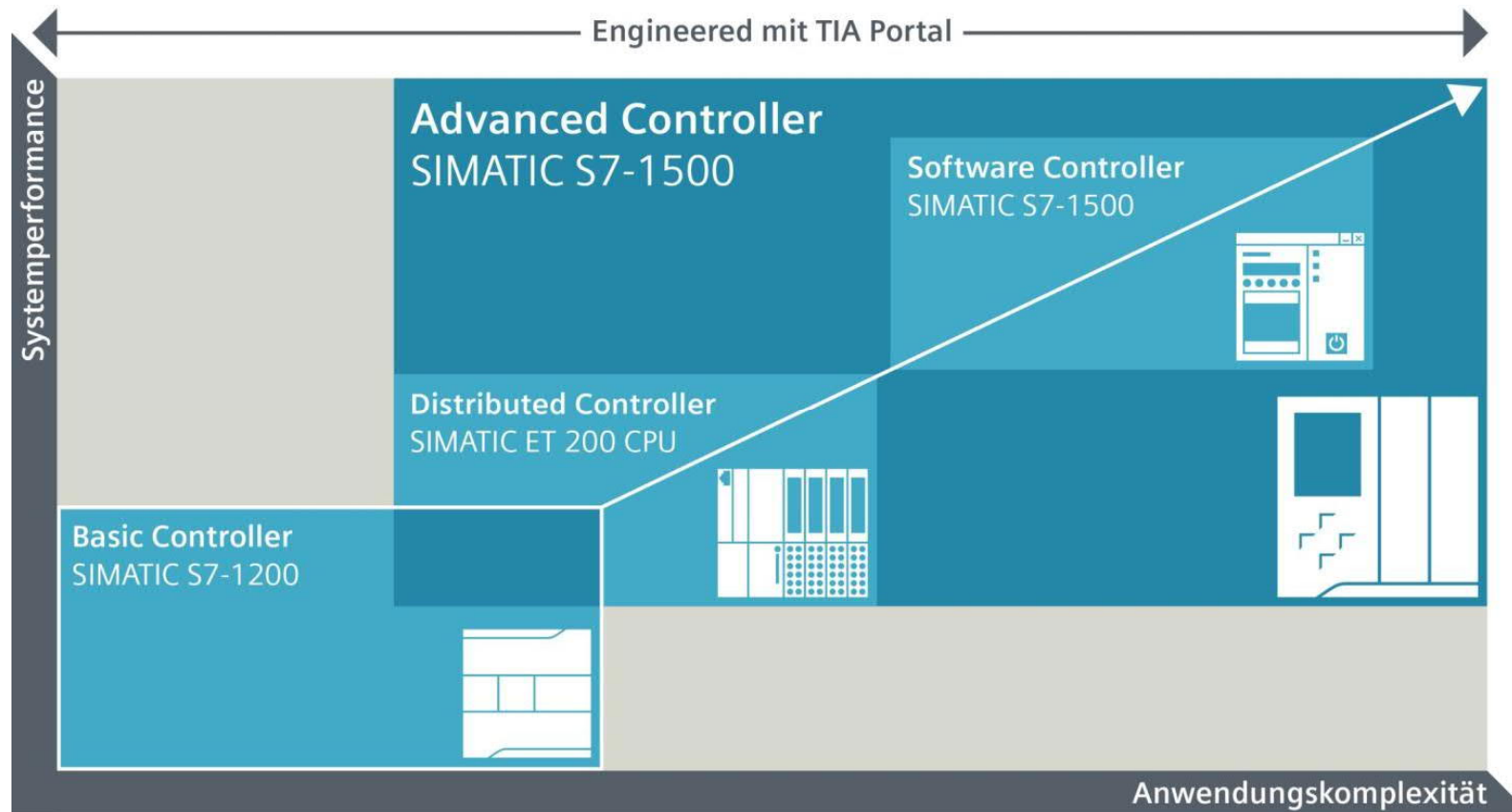

# Advanced Controller – For expanded control applications

**SIEMENS**  
*Ingenuity for life*

## Feature/ function



- One controller for standard- and fail-safe automation
- F-runtime group for autonomous prioritization and timing settings
- All of the controllers with separate status display
- Additional password for the F-configuration and the F-program

## Customer benefits



- Simplified CPU selection thanks to optimized portfolio
- Minimization of types and components
- Efficient engineering in the TIA Portal
- Diagnostic message without programming device
- Maximum protection against manipulation



S7-1500 fail-safe CPUs



Software Controller e.g. CPU1507S F

# Distributed Controller – For distributed control applications

**SIEMENS**  
*Ingenuity for life*

## Feature/ function



- One controller for standard- and fail-safe automation
- Same software concept and features as a fail-safe SIMATIC S7-1500F CPU
- Compact design
- Centrally expandable with all of the standard and fail-safe modules of the ET 200SP or ET 200pro
- F-runtime group for autonomous prioritization and timing settings

## Customer benefits



- Optimized solution for machines with distributed architecture
- Minimization of types and components
- Implement large projects in a small space
- Up to 1/3 gained space
- High functional density and small size
- Efficient engineering in the TIA Portal



Fail-safe ET 200 F-CPU's

# Overview of SIMATIC S7-1500 – The right CPU for every application



	Compact CPUs		Standard-CPU						Technology CPUs				MFP
CPU types	1511C-1 PN	1512C-1 PN	1511F-1 PN	1513F-1 PN	1515F-2 PN	1516F-3 PN/DP	1517F-3 PN/DP	1518F-4 PN/DP	1511TF-1 PN	1515TF-2 PN	1516TF-3 PN/DP	1517TF-3 PN/DP	1518F-4 PN/DP MFP
Interfaces													
Program/ data storage	175 KB 1 MB	250 KB 1 MB	150/ <b>225</b> KB 1 MB	300/ <b>450</b> KB 1.5 MB	500/ <b>750</b> KB 3 MB	1/ <b>1.5</b> MB 5 MB	2/3 MB 8 MB	4/6 MB 20 MB	225/ <b>225</b> KB 1 MB	750/ <b>750</b> KB 3 MB	1.5/ <b>1.5</b> MB 5 MB	3/3 MB 8 MB	4/6 MB 20 MB 50 MB <sup>1</sup>
Bit- performance	60 ns	48 ns	60 ns	40 ns	30 ns	10 ns	2 ns	1 ns	60 ns	30 ns	10 ns	2 ns	1 ns
Max. number of connections	96	128	96	128	192	256	320	384	96	192	256	320	384
Positioning axes • Typical <sup>2</sup> • Maximum <sup>2</sup>	5 10	5 10	5 10	5 10	7 30	7 30	70 128	128 128	5 10	7 30	65 80	70 128	128 128
Width	85 mm	110 mm	35 mm	35 mm	70 mm	70 mm	175 mm	175 mm	35 mm	70 mm	175 mm	175 mm	175 mm

<sup>1</sup> Additional 50 MB memory for ODK applications; <sup>2</sup> For 4ms Servo/IPO cycle

# Overview of SIMATIC S7-1500 – The right CPU for every application

	Distributed Controller			Software Controller		
<b>CPU types</b>	<b>1510SP</b> F-1 PN	<b>1512PN</b> F-1 PN	<b>1516pro</b> F-2 PN	<b>1505SP</b> PC 2(F)	<b>1507S</b> (F)	<b>1508S</b> (F)
<b>Interfaces</b>						
<b>Program/ data storage</b>	100/ <b>150</b> KB 750 KB	200/ <b>300</b> KB 1 MB	1 MB/ <b>1,5</b> MB 5 MB	1/ <b>1,5</b> MB 5 MB	5/ <b>7,5</b> MB 20 MB	10/ <b>12,5</b> MB 100 MB
<b>Bit- performance</b>	72 ns	48 ns	10 ns	10 ns	1 ns <sup>2</sup>	1 ns <sup>2</sup>
<b>Max. number of connections</b>	96	128	96	88	128	192
<b>Positioning axes</b> • Typical <sup>1</sup> • Maximum <sup>1</sup>	5 10	5 10	5 10	30	30 <sup>2</sup>	30 <sup>2</sup>
<b>Width</b>	100 mm	100 mm	135 mm	160 mm		

<sup>1</sup> For 4ms Servo/IPO cycle; <sup>2</sup>auf IPC427E

# Agenda

- 1 System overview
- 2 S7-1500 Controller
  - 2.1 Overview
  - 2.2 Access protection**
  - 2.3 Webserver
  - 2.4 Onboard display
- 3 ET 200
- 4 Module evaluation and addressing
- 5 Application samples and tools

# SIMATIC S7-1500 with Safety Integrated CPU/program protection

The standard protection level is "No protection"

Password only for fail-safe part

Read-only

HMI communication is possible

Complete protection

Any user can read and change the hardware configuration and the blocks

Protection

Select the access level for the PLC.

Access level	Access				Access permission
	HMI	Read	Write	Fail-safe	Password
<input type="radio"/> Full access incl. fail-safe (no protection)	✓	✓	✓	✓	*****
<input type="radio"/> Full access (no protection)	✓	✓	✓		*****
<input type="radio"/> Read access	✓	✓			*****
<input type="radio"/> HMI access	✓				*****
<input checked="" type="radio"/> No access (complete protection)					

# SIMATIC S7-1500 with Safety Integrated CPU/program protection

Separate password protection  
for every access level  
(e.g. for different user groups)

**Protection**

Select the access level for the PLC.

Access level	Access				Access permission
	HMI	Read	Write	Fail-safe	Password
<input type="radio"/> Full access incl. fail-safe (no protection)	✓	✓	✓	✓	*****
<input type="radio"/> Full access (no protection)	✓	✓	✓		*****
<input type="radio"/> Read access	✓	✓			*****
<input type="radio"/> HMI access	✓				*****
<input checked="" type="radio"/> No access (complete protection)					

# Agenda



- 1 System overview
- 2 S7-1500 Controller
  - 2.1 Overview
  - 2.2 Access protection
  - 2.3 **Webserver**
  - 2.4 Onboard display
- 3 ET 200
- 4 Module evaluation and addressing
- 5 Application samples and tools

# SIMATIC S7-1500 with Safety Integrated Web server – representation of the safety data



With the activation of the web server,  
the following information  
is available on the start page

- TIA Portal and STEP 7 Safety versions
- Safety mode enabled/disabled
- Collective signature of the safety program
- CPU time stamp of the last change to the safety program

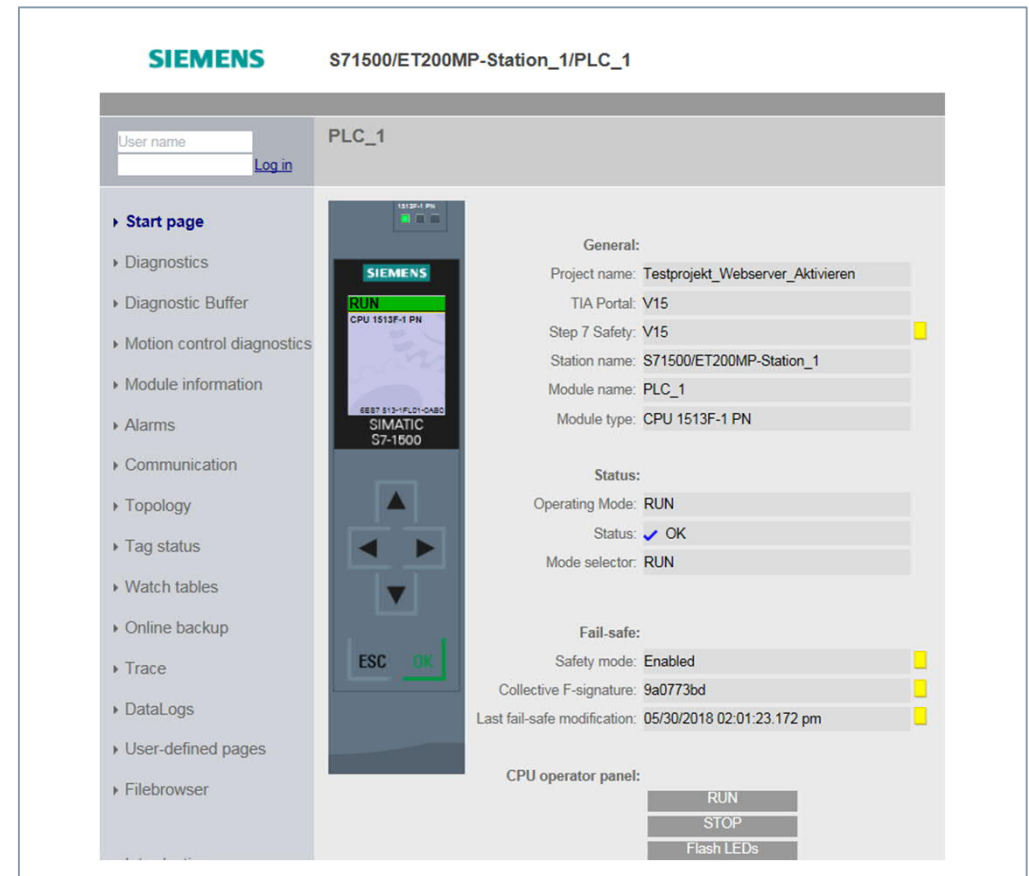

# SIMATIC S7-1500 with Safety Integrated Web server – representation of the safety data



## Information on the F-runtime group

- Name of the F-runtime group
- Collective F-signature
- Current cycle time
- Max. cycle time
- Current runtime
- Max. runtime

The screenshot shows the web server interface for a SIMATIC S7-1500 station. The page title is "SIEMENS S71500/ET200MP station\_1/CPU1516F". The main content area is titled "Diagnostics" and contains a table with the following data:

Identification	Program protection	Memory	Runtime information	Fail-safe
<b>F-runtime group 1</b>				
Collective F-signature:	85186d2e			■
Current cycle time:	50 ms			■
Max. cycle time:	51 ms			■
Current runtime:	3 ms			■
Max. runtime:	4 ms			■

# SIMATIC S7-1500 with Safety Integrated Web server – representation of the safety data



## "Safety" tab of the module information of the F-I/O

- F-parameter signature (with PROFIsafe address)
- F-monitoring time
- F-source address
- F-destination address

The screenshot shows the SIMATIC Manager web server interface for an S71500/ET200MP station. The 'Module information' page is displayed, showing a table of modules in the PROFINET IO-System. The table has columns for Slot, State, Name, Order number, I address, Q address, and Comment. The 'Safety' tab is active, showing parameters for the F-I/O module.

Slot	State	Name	Order number	I address	Q address	Comment
0	✓	ET200SP	6ES7 155-6AU00-0BND			
1	✓	DI 16x24VDC ST_1	6ES7 131-6BH00-0BA0	2		
2	✓	DQ 8x24VDC/0.5A ST_1	6ES7 132-6BF00-0BA0		2	
3	✓	F-DI 8x24VDC HF_1	6ES7 136-6BA00-0CA0	4	4	
4	✓	F-PM-E 24VDC/8A PPM HF_1	6ES7 136-6PA00-0BC0	10	10	
5	✓	DQ 4x24VDC/2A ST_1	6ES7 132-6BD20-0BA0		3	
6	✓	F-DQ 4x24VDC/2A PM HF_1	6ES7 136-6DB00-0CA0	17	17	
7	✓	F-DI 8x24VDC HF_2	6ES7 136-6BA00-0CA0	22	22	
8	✓	CM AS-I Master ST_1	3RK7 137-6SA00-0BC1	28	28	
9	✓	F-CM AS-I Safety ST	3RK7 136-6SC00-0BC1	60	60	
10	✓	Server module_1	6ES7 193-6PA00-0AA0			

State	Identification	Safety	Firmware
	F_Par_CRC (with addresses)	48b7	
	F-monitoring time	150 ms	
	F-source address	1	
	F-destination address	1999	

# SIMATIC S7-1500 with Safety Integrated Web server – user administration



## With the user administration of the Web server, there is the authorization "F-Admin"

- The F-Admin attribute does not provide any authorizations on its own
- The programmer can define which authorizations an F-Admin has
- All of the F-Admins are listed in the Safety Administration

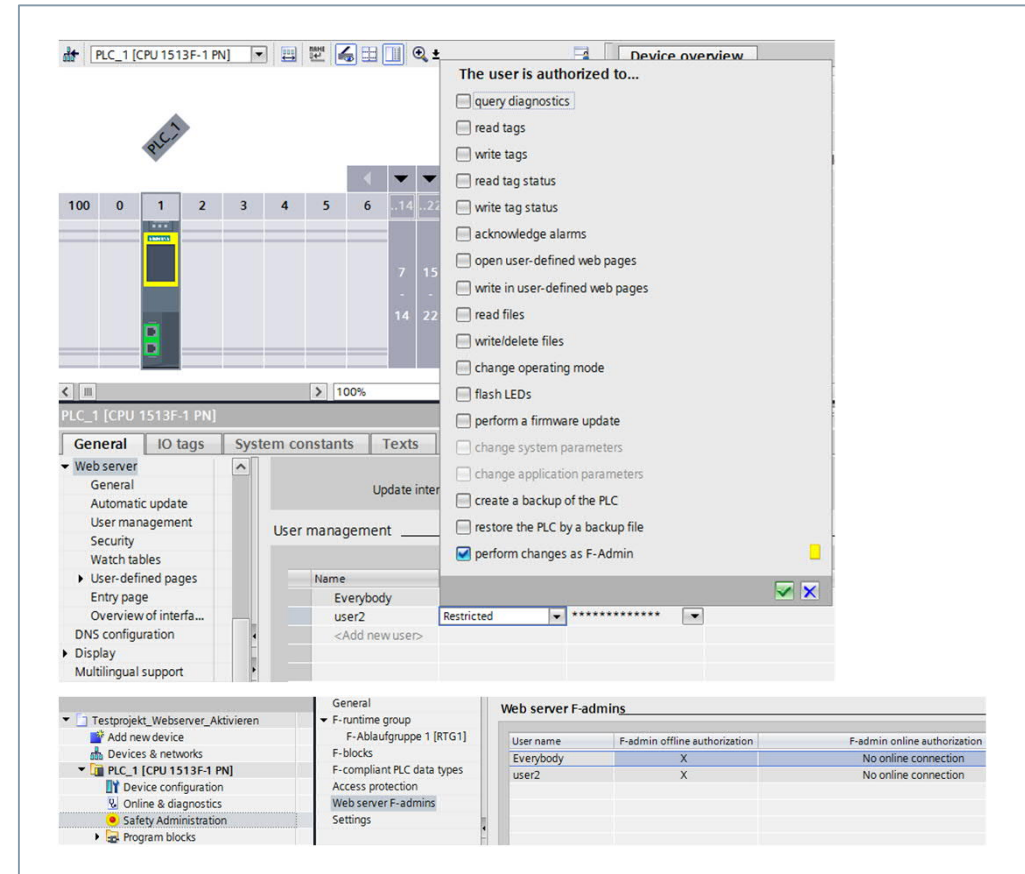

# Agenda

- 1 System overview
- 2 S7-1500 Controller
  - 2.1 Overview
  - 2.2 Access protection
  - 2.3 Webserver
  - 2.4 **Onboard display**
- 3 ET 200
- 4 Module evaluation and addressing
- 5 Application samples and tools

# SIMATIC S7-1500 with Safety Integrated Display – representation of the safety data

**S7-1500 F-CPU**s with a display show the following in the **"Overview"** menu under **"Fail-safe"**

- Safety mode enabled/disabled
- Collective F-signature
- Last fail-safe change
- The version of STEP 7 Safety that was used to compile the safety program
- Information on the F-runtime groups
  - Name of the F-runtime group
  - Collective F-signature
  - Current cycle time
  - Max. cycle time
  - Current runtime
  - Max. runtime



## SIMATIC S7-1500 with Safety Integrated Display – representation of the safety data

**For each F-I/O, the following is displayed under "Fail-safe parameters"**

- F-parameter signature (with address)
- Safety mode
- F-monitoring time
- F-source address
- F-destination address

**The following, additional menu item is displayed in the "Settings" menu under "Protection"**

- Enable/disable F-password  
→ This makes it possible to prevent access to the CPU in RUN, even if the F-password is known

# Agenda

- 1 System overview
- 2 S7-1500 Controller
- 3 **ET 200**
  - 3.1 IP 20 - ET 200SP
  - 3.2 IP 20 - S7-1500/ ET 200MP
  - 3.3 IP 65 - ET 200eco PN
- 4 Module evaluation and addressing
- 5 Application samples and tools

# Agenda

- 1 System overview
- 2 S7-1500 Controller
- 3 ET 200
  - 3.1 IP 20 - ET 200SP
  - 3.2 IP 20 - S7-1500/ ET 200MP
  - 3.3 IP 65 - ET 200eco PN
- 4 Module evaluation and addressing
- 5 Application samples and tools

# ET 200SP – Optimal use of the space in the control cabinet

**SIEMENS**  
*Ingenuity for life*

## Investment protection

Easily add fail-safe modules to the standard I/O

## Easy commissioning

PROFIsafe address is configured via the software and saved in the coding element

## Easy device replacement

PROFIsafe address is automatically imported from the intelligent coding element

## High availability

- Onboard signal test: short circuit, wire break
- Easy and quick fault localization by means of fine-granular error messages in plain text

## Optimal utilization of the control cabinet volume

- Reduction of the module width by 50% or more
- Load group formation without power module

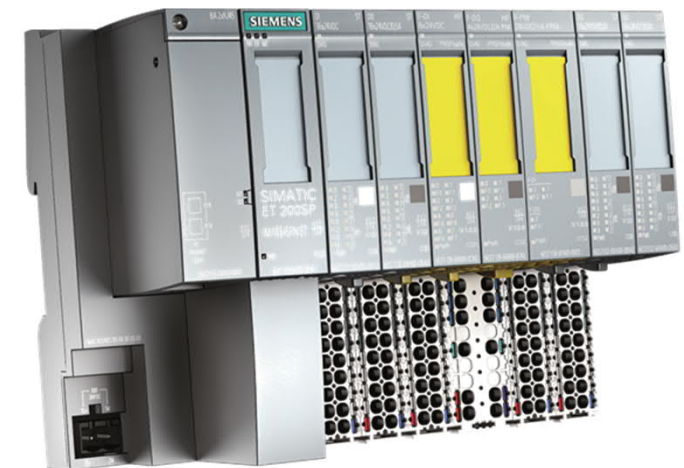

Control cabinet

## ET 200SP – interface modules

ET 200SP	IM DP HF	IM PN ST	IM PN HF
Number of modules	32	32	64
Fail-safe I/O modules	✓	✓	✓
Isochronous mode (synchronization with program cycle)	✓	✓	✓
Hot swapping	Multiple	Simple	Multiple
Media redundancy (MRP)	✗	✓	✓
Prioritized startup	✗	✓	✓
RUN with gaps	✓	✓	✓

# ET 200SP – Select right base unit for F-DI and F-DQ

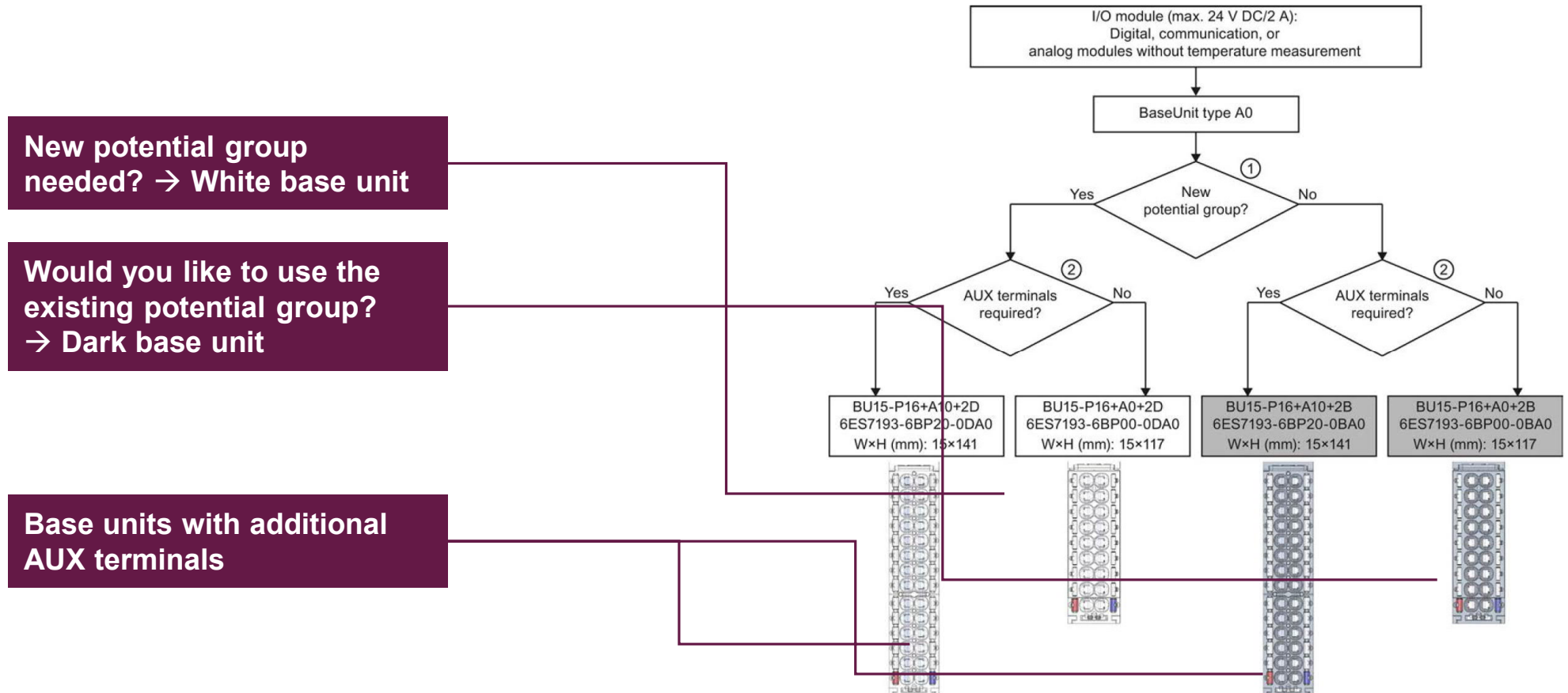

## ET 200SP – Select right base unit for F-PM and F-RQ

**SIEMENS**  
*Ingenuity for life*

### Establishes new potential group for collective shutdown

- Base unit: BU20-P6+A2+4D
- MLFB: 6ES7193-6BP20-0DC0



Power module F-PM-E PPM 24VDC/8A

### Special base unit for F-RQ

- Base unit: BU20-P8+A4+0B
- MLFB: 6ES7193-6BP20-0BF0

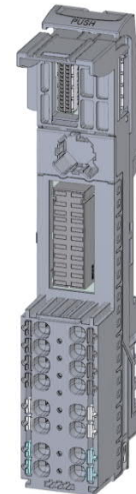

Relay modules F-RQ 1x24VDC/24..230VAC/5A

# ET 200SP – Select right base unit

Principle of operation

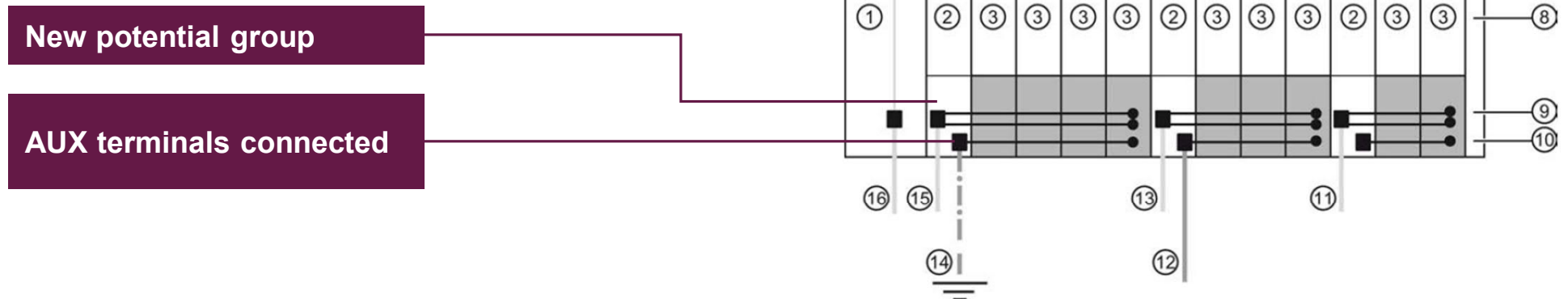

**New potential group**

**AUX terminals connected**

- ① Interface module
- ② BaseUnit BU...D
- ③ BaseUnit BU...B
- ④ Potential group 1
- ⑤ Potential group 2
- ⑥ Potential group 3
- ⑦ Backplane bus
- ⑧ Server module
- ⑨ P1/P2 power buses
- ⑩ AUX bus
- ⑪ Supply voltage L+ (3)
- ⑫ Additionally required voltage
- ⑬ Supply voltage L+ (2)
- ⑭ Protective conductor
- ⑮ Supply voltage L+ (1)
- ⑯ Supply voltage 1L+

## ET 200SP – Select right base unit

Select the right base unit in the hardware configuration

Select the right potential group

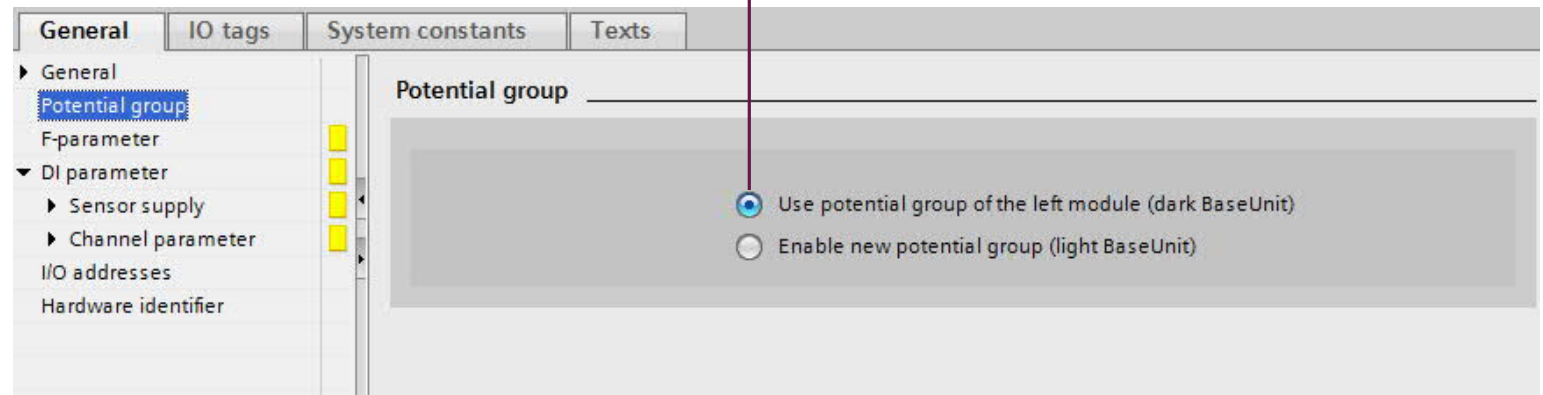

## ET 200SP – Fail-safe digital input module F-DI 8x24VDC HF

**SIEMENS**  
*Ingenuity for life*

### Properties

- Central/distributed application
- 8 inputs up to SIL 2 or 4 inputs up to SIL 3
- 8 outputs for encoder power supply
- Integrated diagnostics of the input circuit by means of short circuit and discrepancy evaluation
- External sensor supply possible
- Channel and module-wide passivation in the event of an error
- Chatter monitoring of the input signals
- Width: 15 mm



# ET 200SP – F-DI 8x24VDC HF – interconnection possibilities



## Emergency stop command device

### Module diagnostics

- Two-channel evaluation (2v2), channels 0+4 form a channel group  
→ 1 signal in the process image
  - Internal encoder supply
  - Short circuit monitoring
  - Discrepancy monitoring
- High diagnostics (up to SIL 3/PL e)

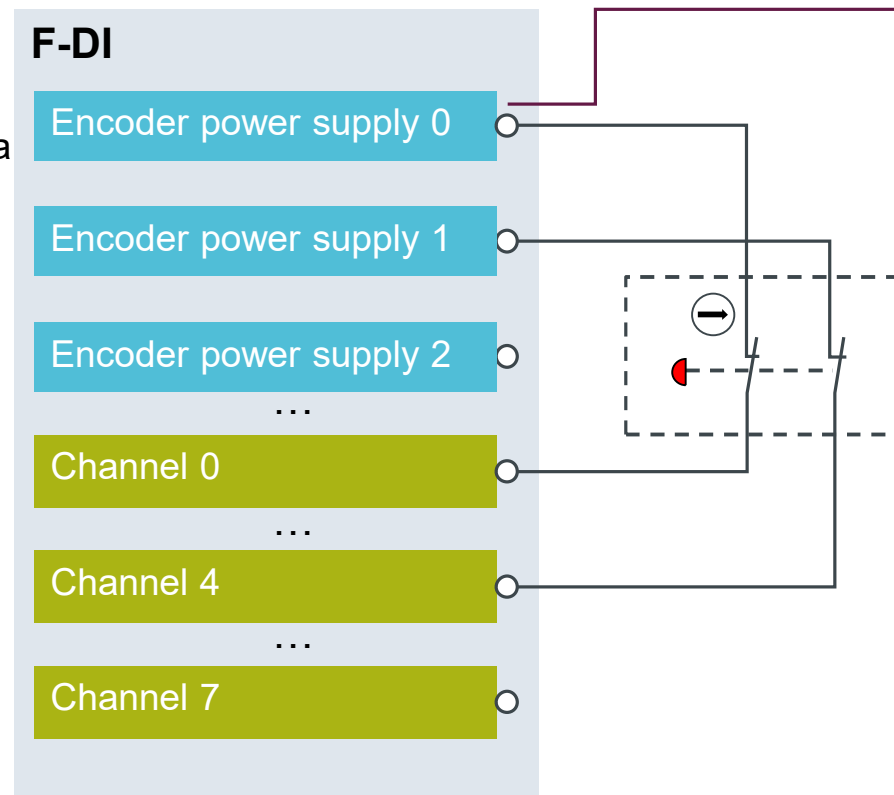

The encoder power supply can be assigned in any way per input



# ET 200SP – F-DI 8x24VDC HF – interconnection possibilities

## Two-hand operator control device

### Module diagnostics

- Single-channel evaluation (1v1)
- Internal encoder supply
- Short circuit monitoring
- No discrepancy monitoring

→ High diagnostics  
(up to SIL 3/PL e)<sup>1</sup>

<sup>1</sup> When using the library's safety function "TWO\_H\_EN", observe EN574  
Synchronization time: 500 ms

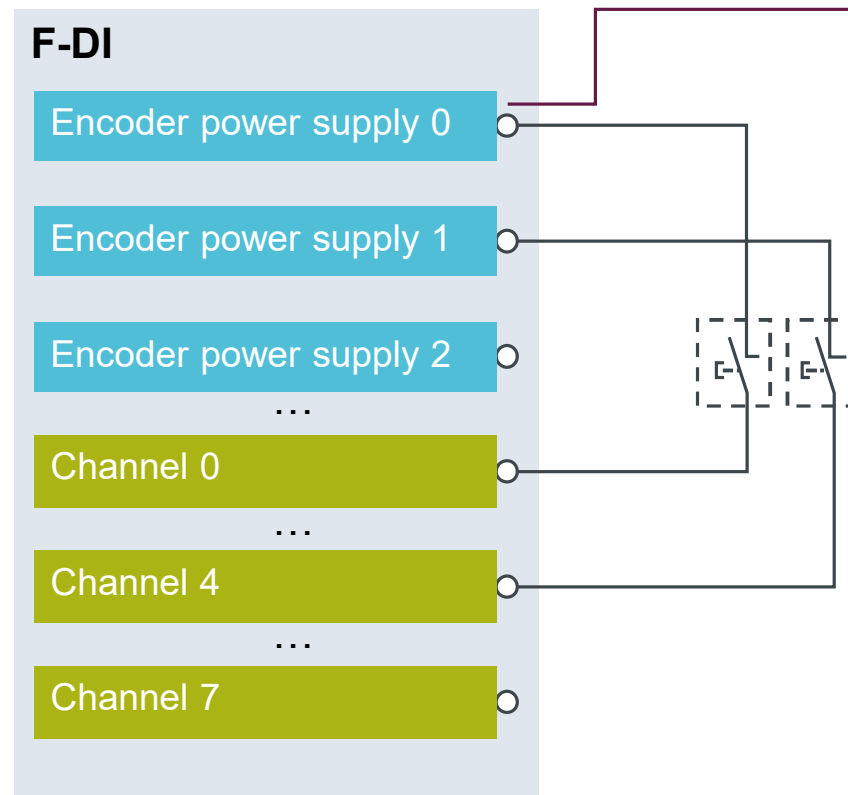

The encoder power supply can be assigned in any way per input



# ET 200SP – F-DI 8x24VDC HF – interconnection possibilities

## OSSD output (safety door switch or light curtain)



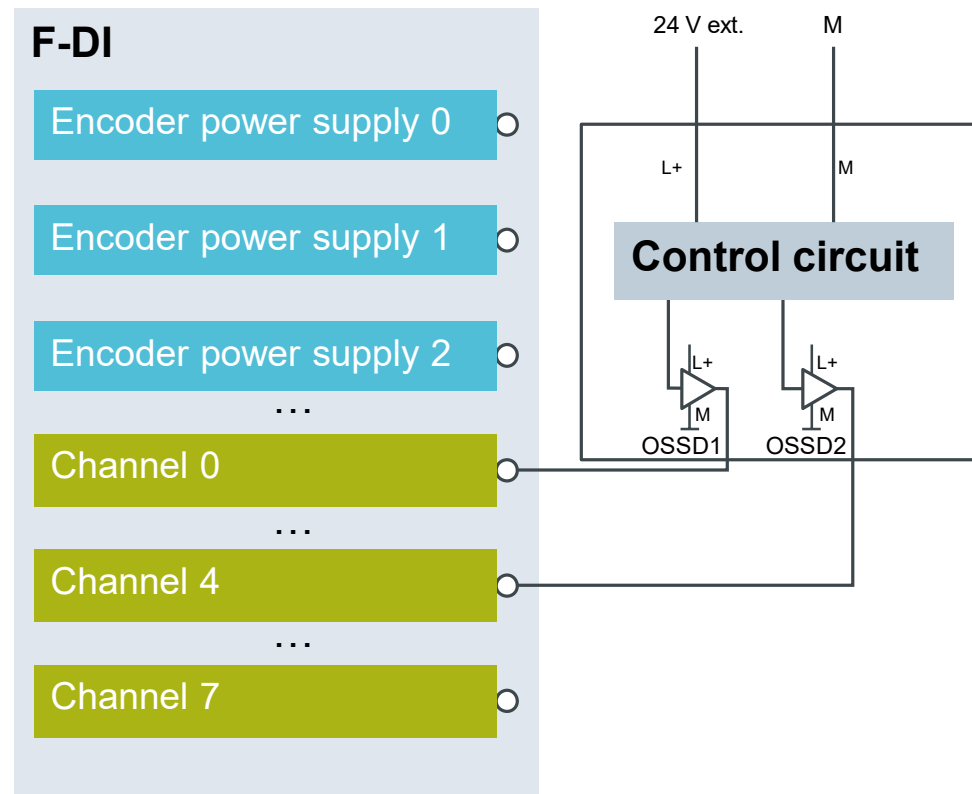

### Module diagnostics

- Two-channel evaluation (2v2), channels 0+4 form a channel group  
→ 1 signal in the process image
  - External encoder power supply
  - No short circuit monitoring of the module (integrated in sensor)
  - Discrepancy monitoring
- High diagnostics (up to SIL 3/PL e)



# ET 200SP – Overview

## Fail-safe digital output modules

	F-DQ 4x24VDC/ 2A PM HF	F-DQ 8x24VDC/ 0.5A PP HF	F-RQ 1x24VDC/ 24..230VAC/5A	F-PM-E 24 V DC/ 8 A PPM
				
Number of F-outputs	4	8	1	1
Switching capacity	24 V DC/2 A	24 V DC/0.5 A	24 V DC/24.. 230 V AC/5 A	24 V DC/8 A
Output type	Electronic plus-minus	Electronic plus-minus	Relay	Electronic plus-minus or plus-plus
Usable up to	SIL 3/PL e	SIL 3/PL e	SIL e/PL e (if controlled via F-DQ 4)	SIL 3/PL e SIL 2/PL d <sup>1</sup>

<sup>1</sup> For collective shutdown via standard modules

## ET 200SP – F-DQ 4x24VDC/2A PM HF

**SIEMENS**  
*Ingenuity for life*

### Properties

- Central/distributed application
- 4 fail-safe digital outputs 2A (P/M-switching) up to SIL 3
- Open circuit/overload monitoring
- Cross circuit monitoring
- Module passivation in fault scenario
- Width: 15 mm



F-DQ 4x24VDC/2A PM HF

# ET 200SP – F-DQ 4x24VDC/2A PM HF – interconnection possibilities



## Two-channel contactor control

### Module diagnostics

- Short circuit P to L+
- Short circuit M to ground
- Cross circuit monitoring  
P-... to P-...  
or M-... to M-...
- Open circuit/overload  
monitoring  
P-switch

→ High diagnostics  
(up to SIL 3/PL e)<sup>1</sup>

<sup>1</sup> When implementing feedback circuit  
monitoring  
(FDBACK block) in the F-user program

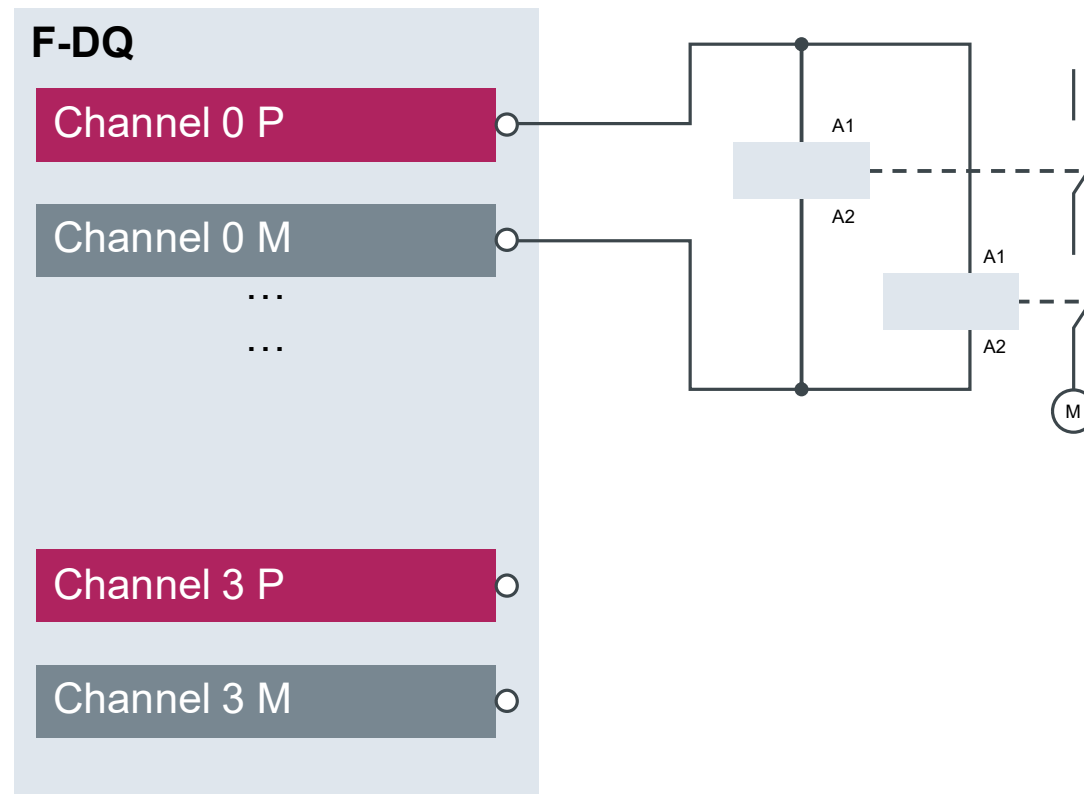

## ET 200SP – F-DQ 4x24VDC/2A PM HF – dark test

### Dark test



- Test required, permanently activated
- Test signal while channel is active ("1")
- Alternating brief deactivation of P or M and read back of the output channel
- Sufficiently slow actuators do not respond to test signal

#### The dark test detects the following errors

- Internal errors of the P and M switches
- Short circuit, e.g. P0 to L+ or M0 to ground
- Cross circuit, e.g. P0 to P1 or M0 to M1

**SIEMENS**  
*Ingenuity for life*

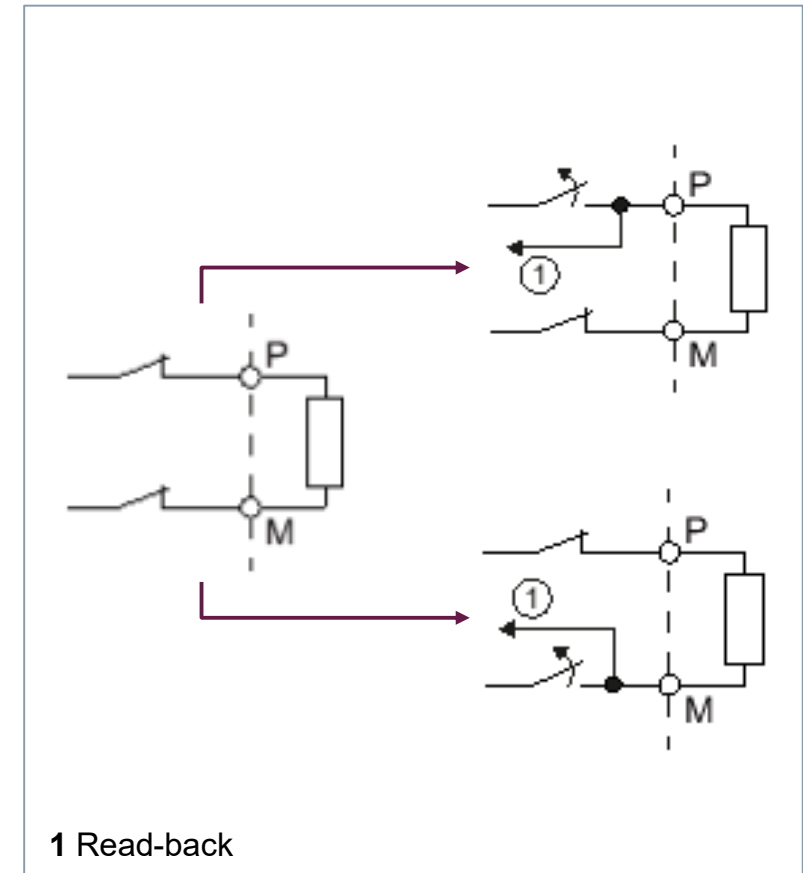

## ET 200SP – F-DQ 4x24VDC/2A PM HF – switch-on test

### Switch-on test



- Test required, permanently activated
- Test signal while channel is inactive ("0")
- Alternating brief activation of P or M and read back of the output channel
- Actuator is not activated by the test signal

#### The switch-on test detects the following errors

- Internal errors of the P and M switches
- Short circuit, e.g. P0 to L+ or M0 to ground
- Cross circuit, e.g. P0 to P1 or M0 to M1

**SIEMENS**  
*Ingenuity for life*

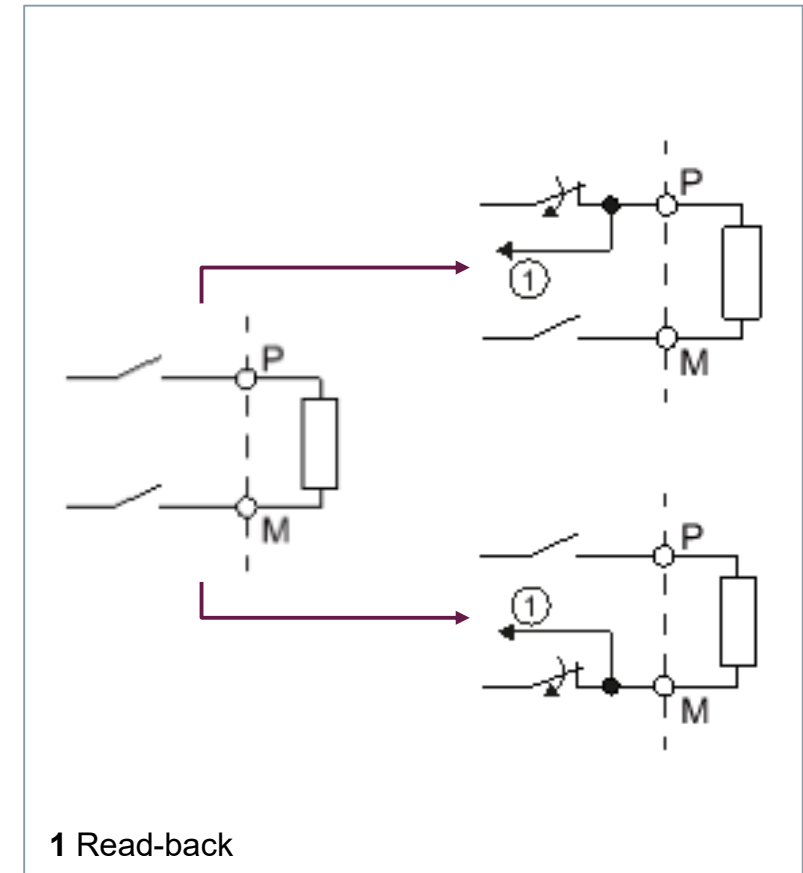

## ET 200SP – F-DQ 4x24VDC/2A PM HF – light test

### Light test



- Test optional, to be parameterized by user
- Test signal while channel is inactive ("0")
- Simultaneous brief activation of P or M and read back of the output channel
- Sufficiently slow actuator does not respond to test signal

#### The light test detects the following errors

- Overload with signal "0" at output
- Open circuit with signal "0" at output

**SIEMENS**  
*Ingenuity for life*

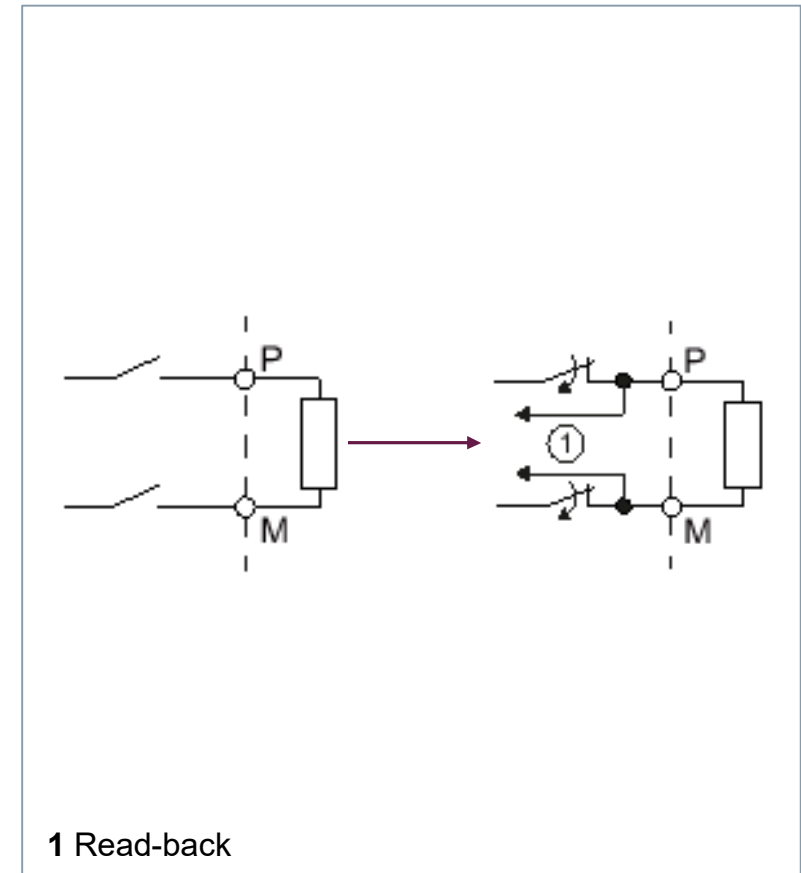

## ET 200SP – F-DQ 8x24VDC/0.5A PP HF

**SIEMENS**  
*Ingenuity for life*

### Properties

- Central/distributed application
- 8 fail-safe digital outputs 0.5 A (P/P-switching) up to SIL 3
- Overload monitoring
- Cross circuit monitoring
- Module passivation in fault scenario
- Dark test can be deactivated for 48 hours
- "RIOforFA-Safety" profile is supported
- Width: 15 mm



F-DQ 4x24VDC/2A PM HF

In the event of a cross circuit between a positive potential (e.g. L+) and DQ-PPn, the activated actuator can no longer be shut down.

# ET 200SP – F-DQ 8x24VDC/0.5A PP HF – interconnection possibilities

## Contactor with fail-safe control input

### Module diagnostics

- Short circuit P to L+
- Cross circuit monitoring P-... to P-
- Diagnostics up to SIL 2

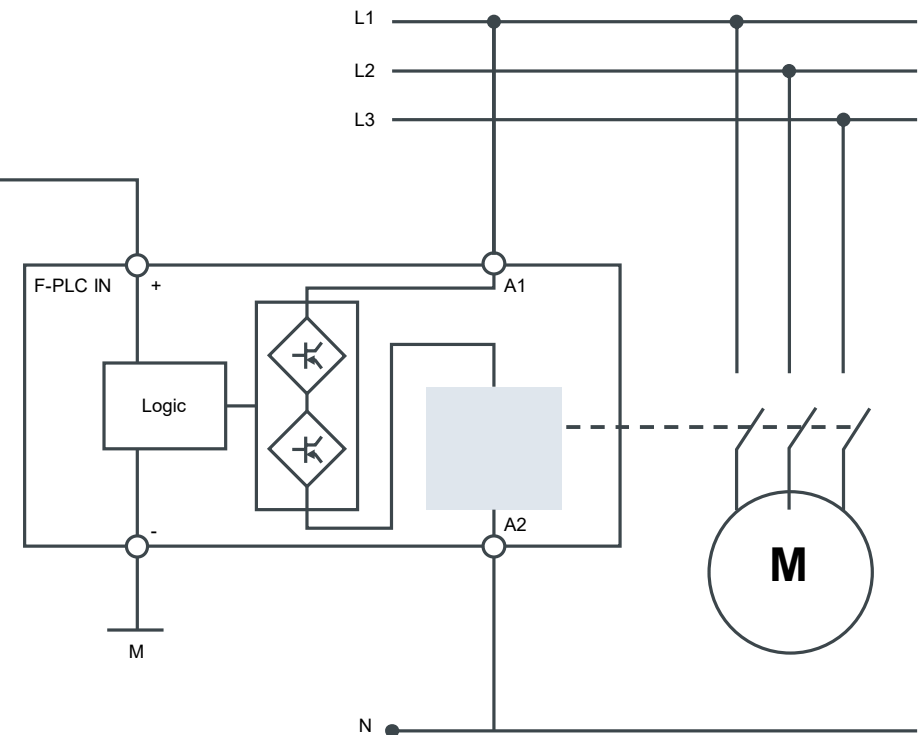

# ET 200SP – F-DQ 8x24VDC/0.5A PP HF – interconnection possibilities



## Two-channel contactor control

### Module diagnostics

- Short circuit P to L+
- Cross circuit monitoring P-... to P-
- Missing supply

→ High diagnostics  
(up to SIL 3/PL e)<sup>1</sup>

<sup>1</sup> When implementing feedback circuit monitoring (FDBACK block) in the F-user program

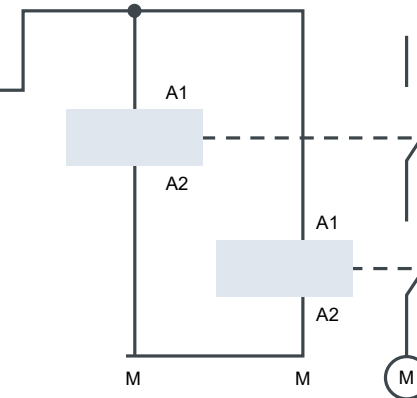
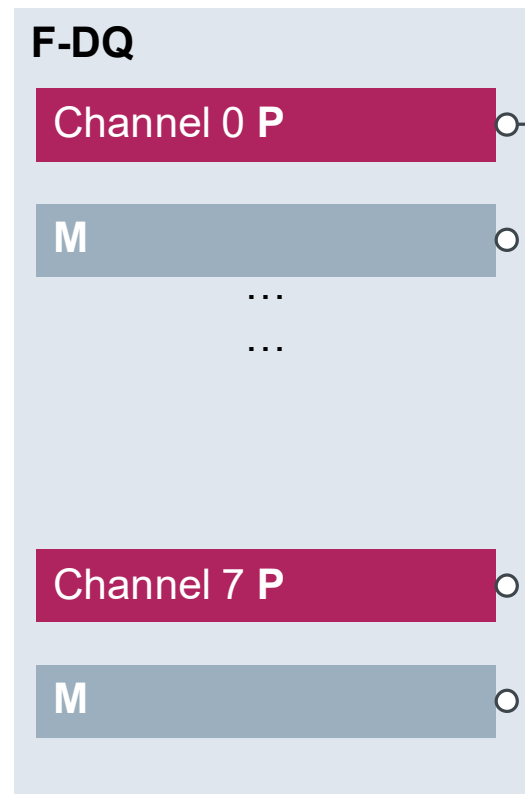

# ET 200SP – F-DQ 8x24VDC/0.5A PP HF – interconnection possibilities

## Direct wiring to F-DI

### Module diagnostics

- Short circuit P to L+
- Cross circuit monitoring P-... to P-

→ High diagnostics  
(up to SIL 3/PL e)

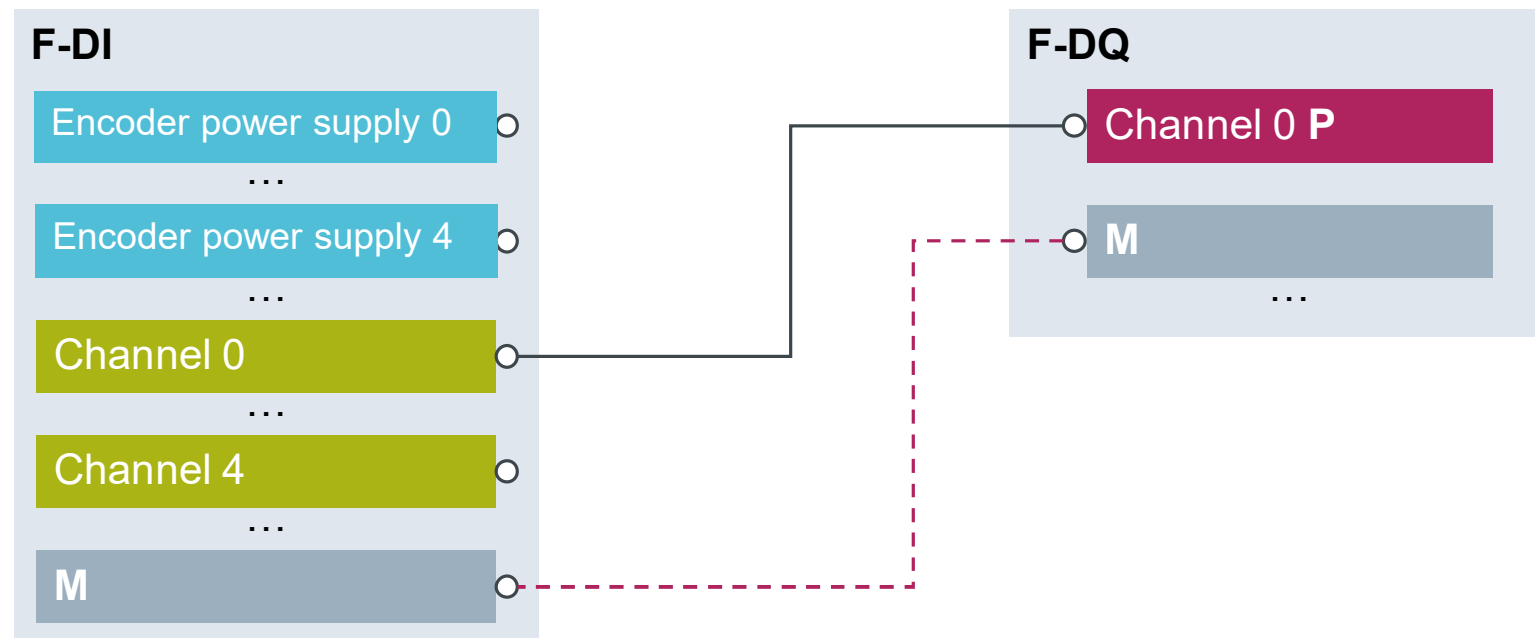

When supplying both modules from different power supply units, a ground equalization must take place.

## ET 200SP – F-RQ 1x24VDC/24..230VAC/5A

**SIEMENS**  
*Ingenuity for life*

### Properties

- Central/distributed application
- Module with a relay output (two isolated NO contacts)
- Control voltage 24 V DC
- Total current for both NO contacts, max. 5 A
- Isolated from the control voltage
- Readback channel in PII
- up to SIL 3/PL e for activation with F-DQ (P/M)
- Width: 20 mm



# ET 200SP – F-RQ 1x24VDC/24..230VAC/5A – interconnection possibilities



## Two-channel contactor control

### Module diagnostics

- Relay contacts with module-internal feedback circuit signal in the PII
- Galvanically isolated switching contacts

→ High diagnostics (up to SIL 3/PL e)<sup>1</sup>

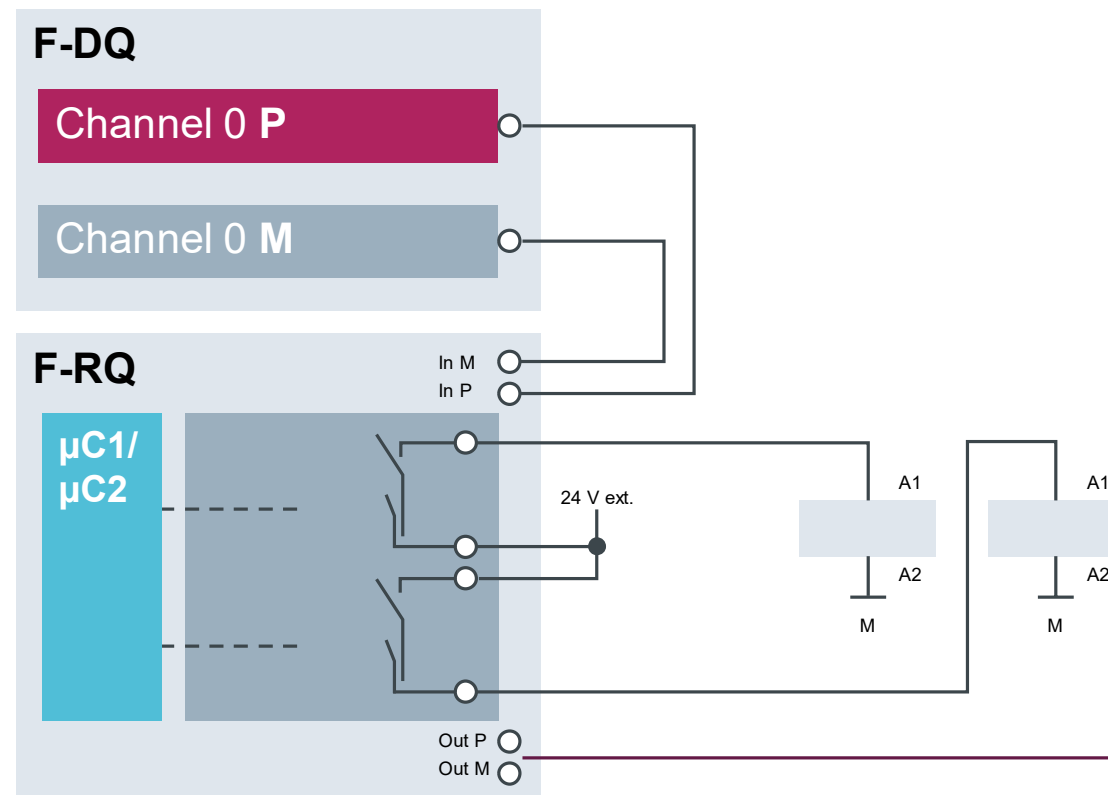

**Cascading signal  
for controlling  
additional  
F-RQ modules**

<sup>1</sup> Activated by F-DQ (P/M-switching)

## ET 200SP – F-PM-E 24VDC/8A PPM

**SIEMENS**  
*Ingenuity for life*

### Properties

- Central/distributed application
- Two fail-safe digital inputs up to SIL 2/PL d or a fail-safe digital input up to SIL 3/PL e
- Two outputs for encoder power supply
- A fail-safe digital output, PM or PP-switching, up to SIL 3/PL e (direct) or SIL 2/PL d for collective shutdown via std. DQ
- Output current up to 8 A
- Short circuit/cross circuit/open circuit monitoring
- Dark test can be deactivated (from FW V2.0)  
→ No change for the collective shutdown of standard modules
- Module passivation in fault scenario  
→ F-DQ only reaches SIL 2
- Module width: 20 mm



F-PM-E 24 V DC/8 A PPM

# ET 200SP – F-PM-E 24VDC/8A PPM – interconnection possibilities

## Safety-oriented shutdown of standard DQ modules

- High diagnostics as with F-DI/F-DQ modules (cross circuit/short circuit monitoring, discrepancy evaluation)
- Evaluation of the safety function directly via F-PM-E module (one/two-channel evaluation) or in F-CPU
- Quick collective shutdown of standard DQ modules up to SIL 2

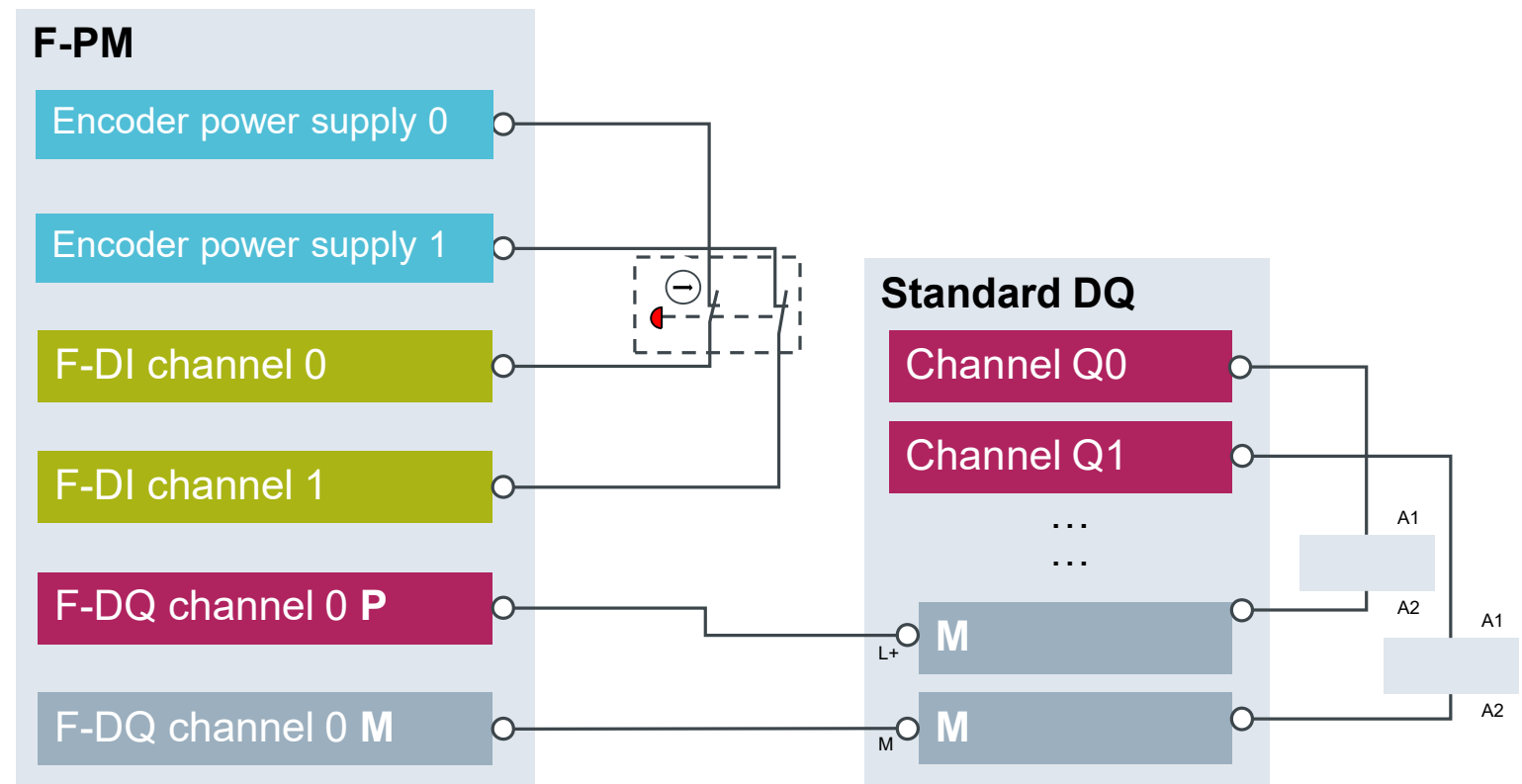

## ET 200SP – Fail-safe analogue input module F-AI 4xI 0(4)...20 mA 2-/4-wire HF

**SIEMENS**  
*Ingenuity for life*

### Properties

- Central/distributed application
- 4 inputs up to SIL 2 or 2 inputs up to SIL 3
- 4 outputs for encoder power supply
- Measuring ranges: 0..20 mA and 4..20 mA
- Resolution 16-bit incl. sign
- External encoder supply possible
- Open circuit detection
- Channel and module-wide passivation in the event of an error
- "RIOforFA-Safety" profile is supported
- Width: 15 mm



F-AI 4xI 0(4) ... 20 mA 2/4-wire HF



# ET 200SP – F-AI 4xI 0(4)...20 mA 2-/4-wire HF – interconnection possibilities

## Two-channel evaluation with 4-wire transducer

### Module diagnostics

- SIL 3/Cat. 4/PL e
- Internal encoder supply (external also possible)
- Open circuit monitoring
- Short circuit monitoring

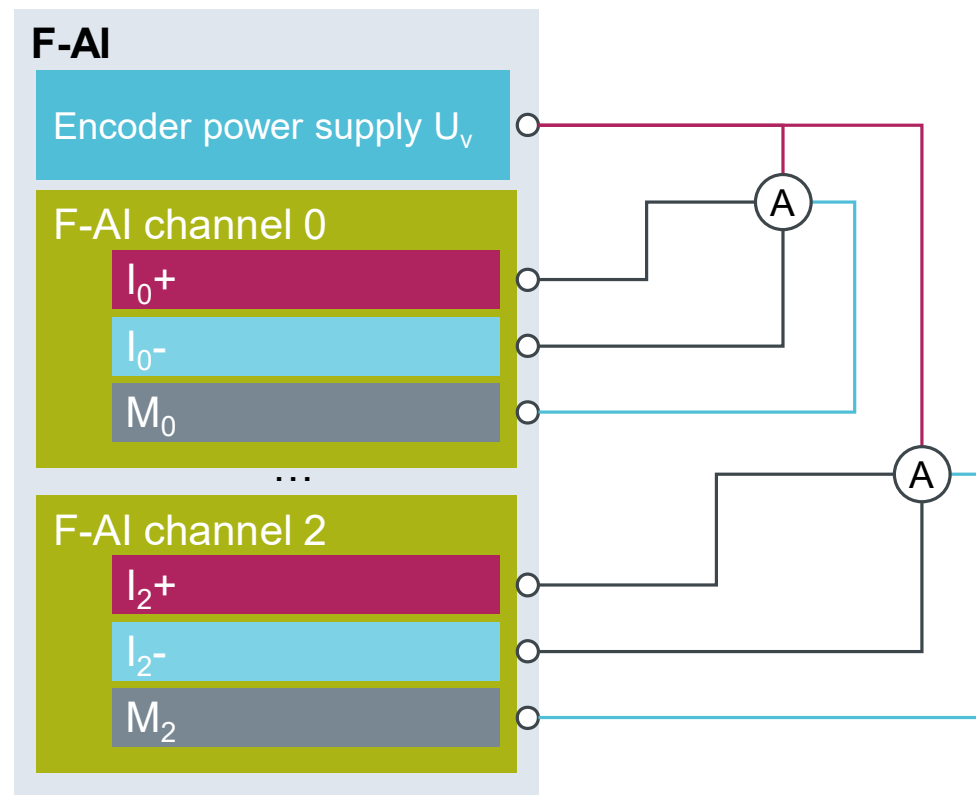

## ET 200SP – F-motor starter

**SIEMENS**  
*Ingenuity for life*

### Properties

- Switching and protective module for three-phase induction motors, single-phase AC motors and three-phase induction motors
- Integrated short circuit and overload protection
- Direct or reversing start function
- Diagnostic functions
- Energy management functions
- Shutdown up to SIL 3 (according to IEC 61508), PL e and Cat.4 (according to EN ISO 13849-1) possible



## ET 200SP – F-motor starter – Base unit explanation

- **MS1:** BU with infeed of **24 V** and **400 V**
- **MS2:** BU with infeed of **400 V**  
(24 V bridged from the previous BU)
- **MS3:** BU with infeed of **24 V**  
(400 V bridged from the previous BU)
- **MS4:** BU without an infeed  
(24 V and 400 V bridged from the previous BU)
- **MS5:** BU with **F-DI** input and **400 V** infeed
- **MS6:** BU with **F-DI** input (400 V  
bridged from the previous BU)

The fail-safe motor starter can be used with any BU (MS1 – MS6) up to **SIL 3**:

The 24 V supply is an infeed by means of an **F-DQ** or **F-PM-E** module (also via BUs).

Advantages when using BU30-**MS5** and BU30-**MS6**

- Communication with the motor starter is retained in the event of a shutdown
- Quick restart after a fail-safe shutdown

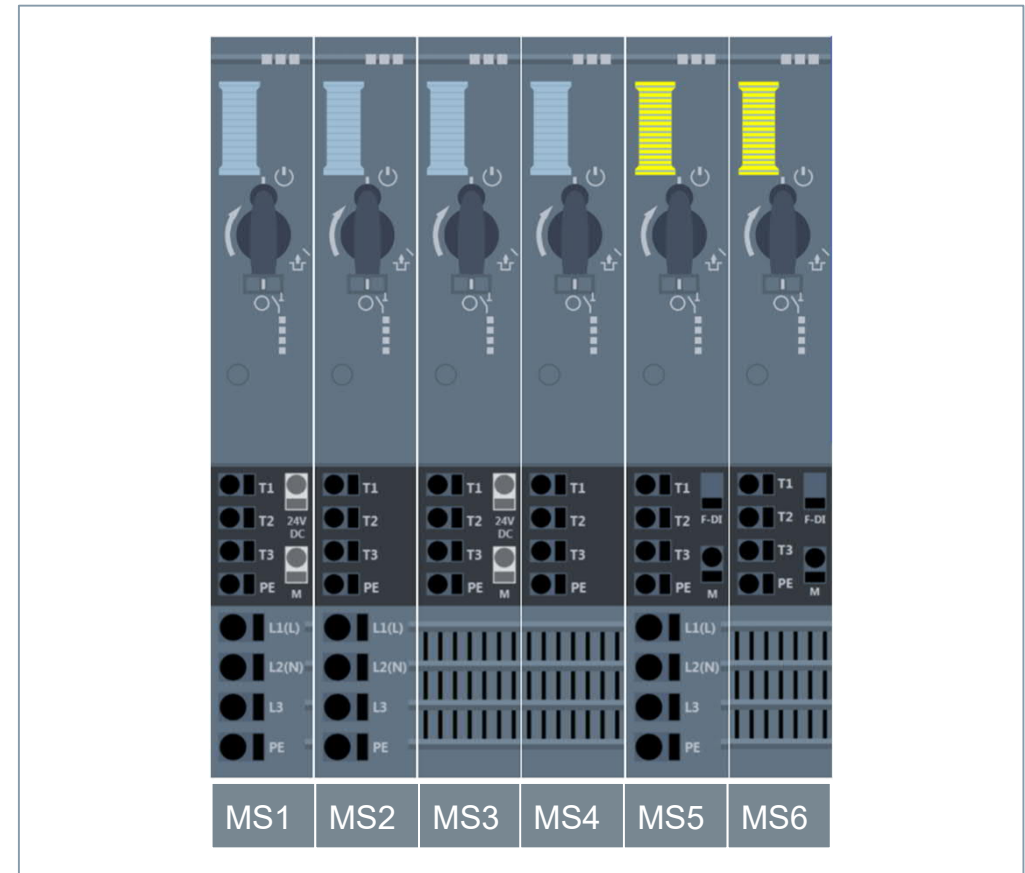

# ET 200SP – F-motor starter – interconnection options

## Shutdown of the MS via F-DQ

### Properties

- SIL 3 /Cat. 4/PL e
- Each motor starter is controlled with one channel of an F-DQ
- The diagnostics of each MS is retained during a fail-safe shutdown
- Quick re-activation possible
- Collective shutdown conditionally possible

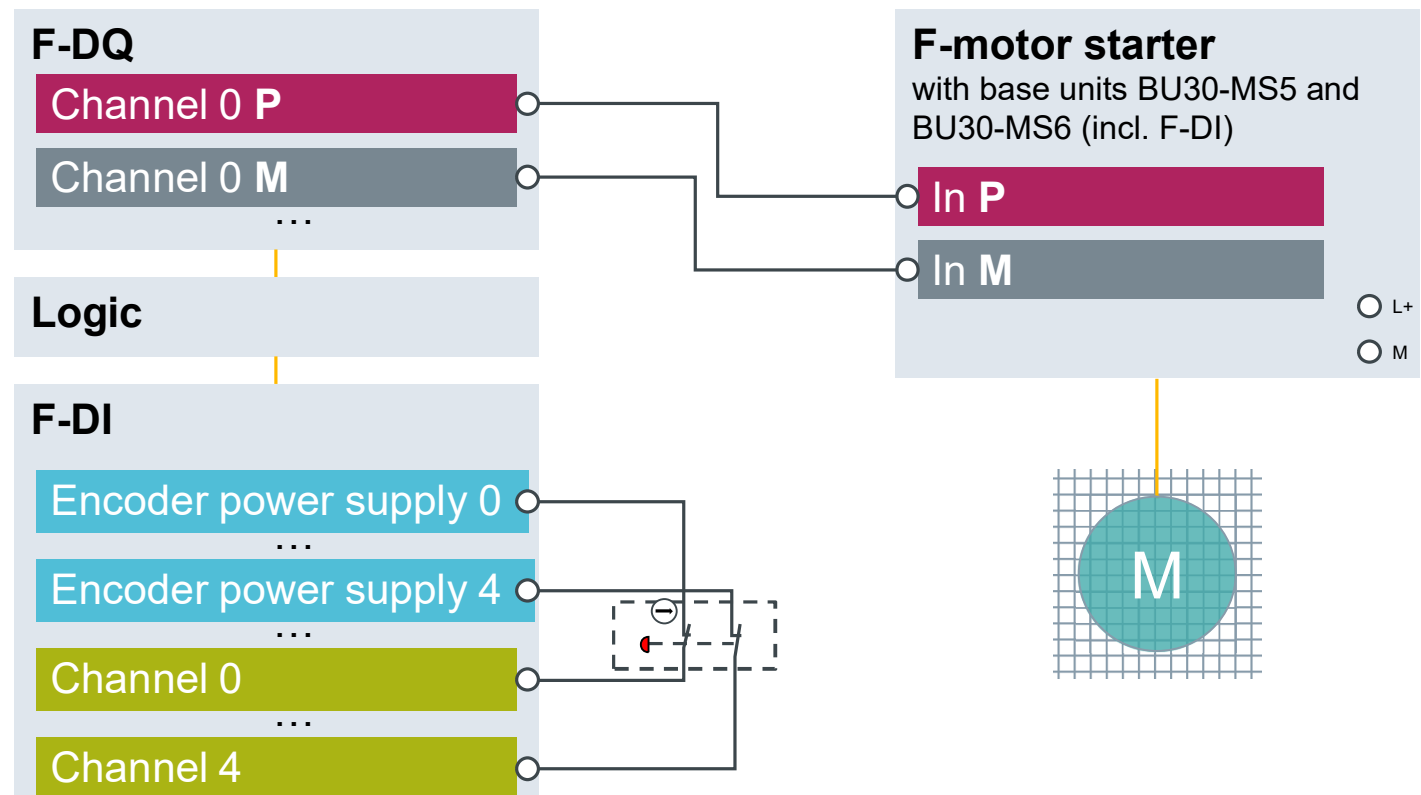

# ET 200SP – F-motor starter – interconnection options

## Shutdown of the MS via F-PM

### Properties

- SIL 3/Cat. 4/PL e
- 24 V of the motor starter is safely switched with the shutdown signal (backplane bus) of the F-PM-E
- No corresponding diagnostics of the MS are available during a safe shutdown
- After the 24 V has been re-activated, the MS must be restarted
- Collective shutdown possible

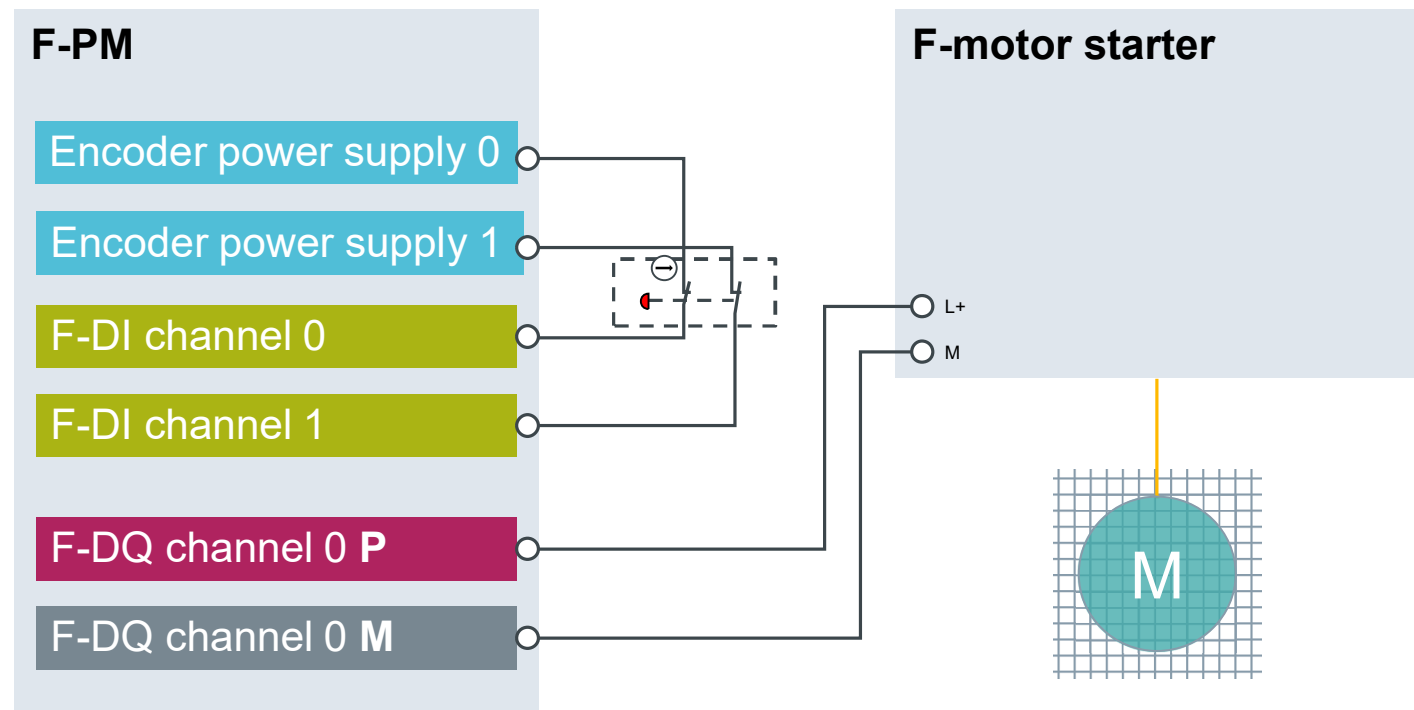

# ET 200SP – F-CM AS-i Safety ST

**SIEMENS**  
*Ingenuity for life*

## Properties

- Central/distributed application
- Converts the ASIsafe protocol to PROFIsafe
- Secure communication in both directions possible (SIL 3)
- Up to 31 secure AS-i slaves can be evaluated per network
- Up to 16 secure AS-i actuators can be controlled per network
- Integration as 31 F-DI/16 F-DO modules
- One F-address per AS-i network
- Module width: 20 mm



F-CM AS-i Safety ST

# ET 200SP – CM AS-i master and F-CM AS-i safety

**SIEMENS**  
*Ingenuity for life*

The AS-i master for the ET 200SP provides easy access to the AS-i slave from the SIMATIC program.

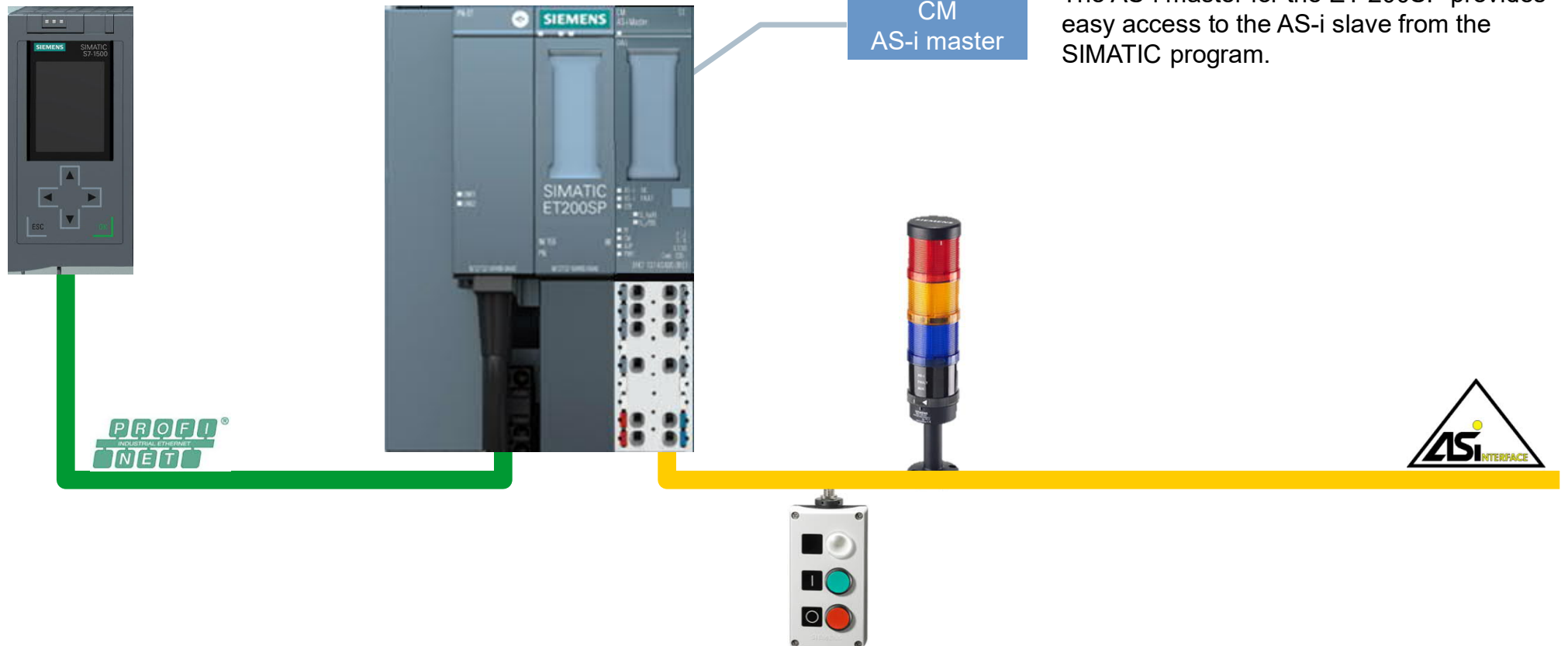

# ET 200SP – CM AS-i master and F-CM AS-i safety

**SIEMENS**  
*Ingenuity for life*

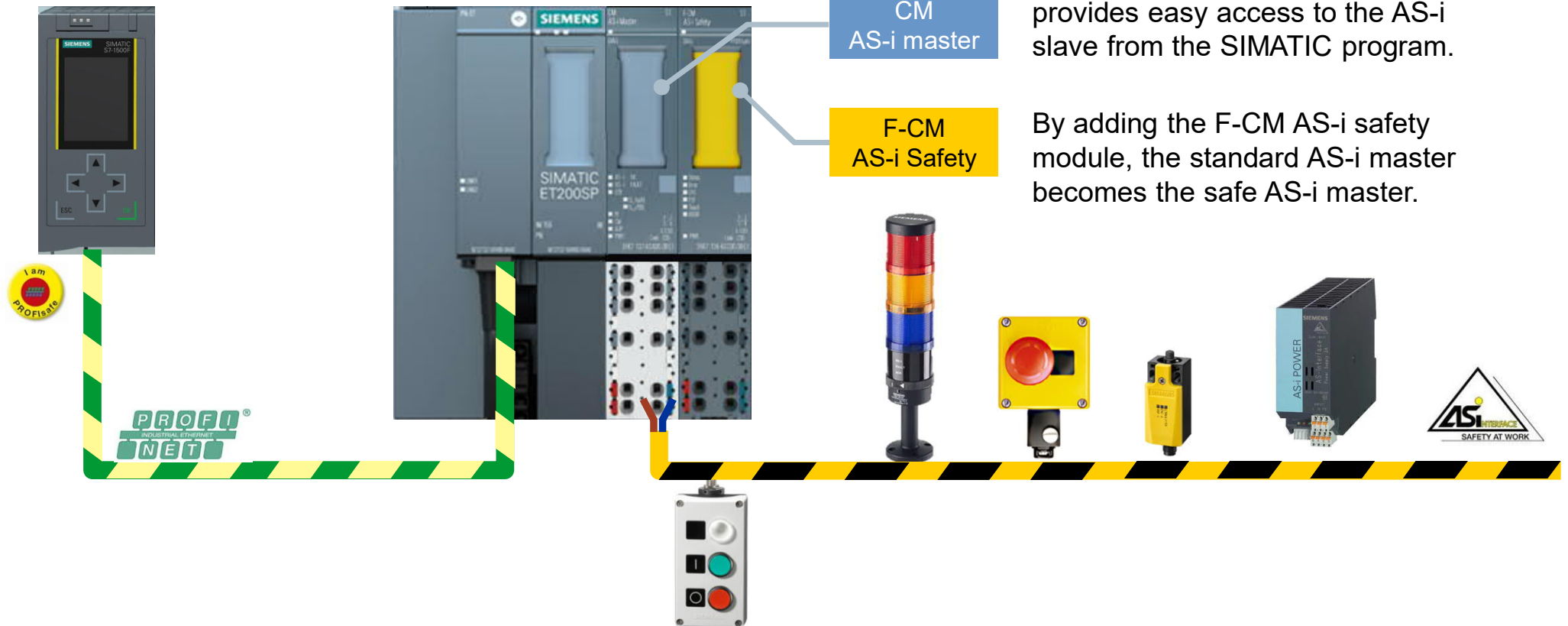

The AS-i master for the ET 200SP provides easy access to the AS-i slave from the SIMATIC program.

By adding the F-CM AS-i safety module, the standard AS-i master becomes the safe AS-i master.

# Agenda

- 1 System overview
- 2 S7-1500 Controller
- 3 ET 200
  - 3.1 IP 20 - ET 200SP
  - 3.2 **IP 20 - S7-1500/ ET 200MP**
  - 3.3 IP 65 - ET 200eco PN
- 4 Module evaluation and addressing
- 5 Application samples and tools

# SIMATIC ET 200MP – The modular I/O system for the central control cabinet

**SIEMENS**  
*Ingenuity for life*

## Investment protection

Easily add fail-safe modules to the standard I/O

## Easy commissioning

PROFIsafe address is configured via the software and saved in the coding element

## Easy device replacement

PROFIsafe address is automatically imported from the intelligent coding element

## High availability

- Onboard signal test: short circuit, wire break
- Easy and quick fault localization by means of fine-granular error messages in plain text

## Optimal utilization of the control cabinet volume

- Implementation of a multi-tier system without changing the system
- High-channel modules



## ET 200MP – interface modules

ET 200MP	IM 155-5 DP ST	IM 155-5 PN ST	IM 155-5 PN HF
Number of modules	12	30	30
Fail-safe I/O modules	✓	✓	✓
Isochronous mode (synchronization with program cycle)	✓	✓	✓
Media redundancy (MRP)	✗	✓	✓
Prioritized startup	✗	✓	✓
Shared device	✗	✓	✓

## ET 200MP – Fail-safe digital input module F-DI 16x24VDC

### Properties

- Central/distributed application
- 16 inputs up to SIL 2 or 8 inputs up to SIL 3
- 4 outputs for encoder power supply
- Integrated diagnostics of the input circuit by means of short circuit and discrepancy evaluation
- External sensor supply possible
- Module passivation in fault scenario
- Pulse stretching and chatter monitoring of the input signals
- "RIOforFA-Safety" profile is supported
- Width: 35 mm

**SIEMENS**  
*Ingenuity for life*



F-DI 16x24VDC

# ET 200MP – F-DI 16x24VDC – interconnection possibilities

## Emergency stop command device

### Module diagnostics

- Two-channel evaluation (2v2), channels 0+8 form a channel group  
→ 1 signal in the process image
  - Internal encoder supply
  - Short circuit monitoring
  - Discrepancy monitoring
- High diagnostics (up to SIL 3/PL e)

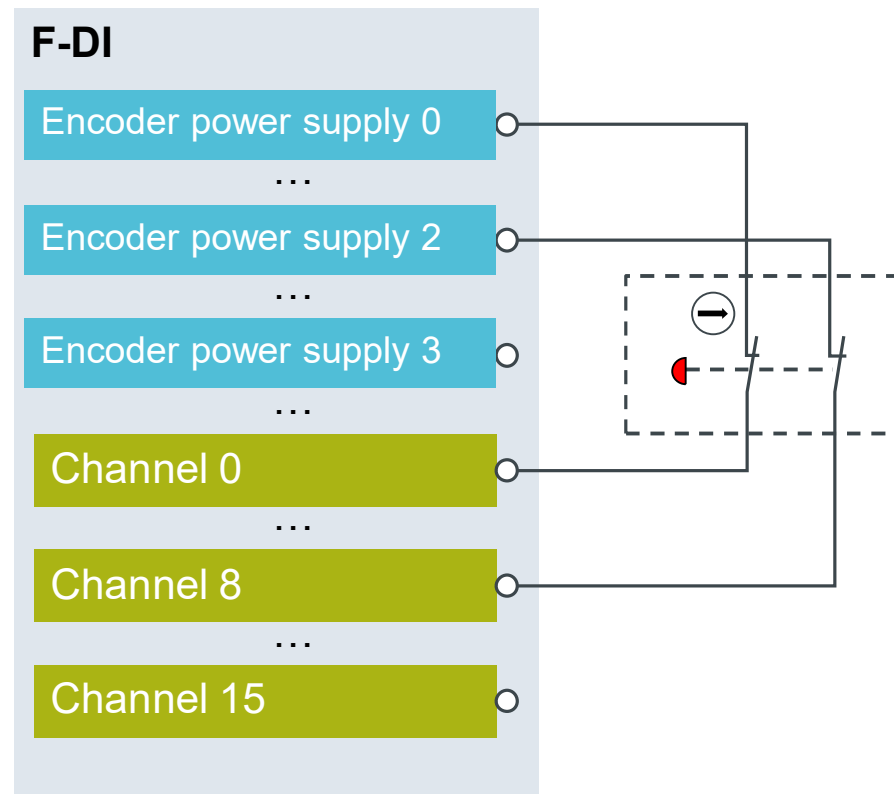

# ET 200MP – F-DI 16x24VDC – interconnection possibilities

## Two-hand operator control device

### Module diagnostics

- Single-channel evaluation (1v1)
- Internal encoder supply
- Short circuit monitoring
- **No** discrepancy monitoring

→ High diagnostics  
(up to SIL 3/PL e)<sup>1</sup>

<sup>1</sup> When using the library's safety function "TWO\_H\_EN", observe EN574 Synchronization time: 500 ms

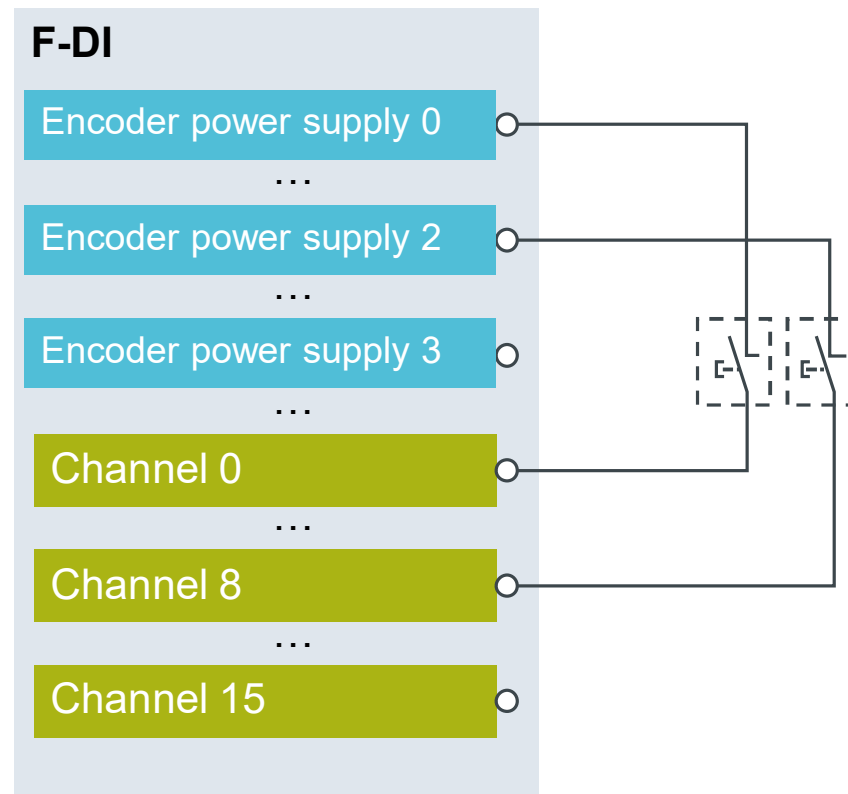

# ET 200MP – F-DI 16x24VDC – interconnection possibilities

## OSSD output (safety door switch or light curtain)

### Module diagnostics

- Two-channel evaluation (2v2), channels 0+8 form a channel group → 1 signal in the process image
- External encoder power supply
- Short circuit monitoring
- Discrepancy monitoring

→ High diagnostics (up to SIL 3/PL e)

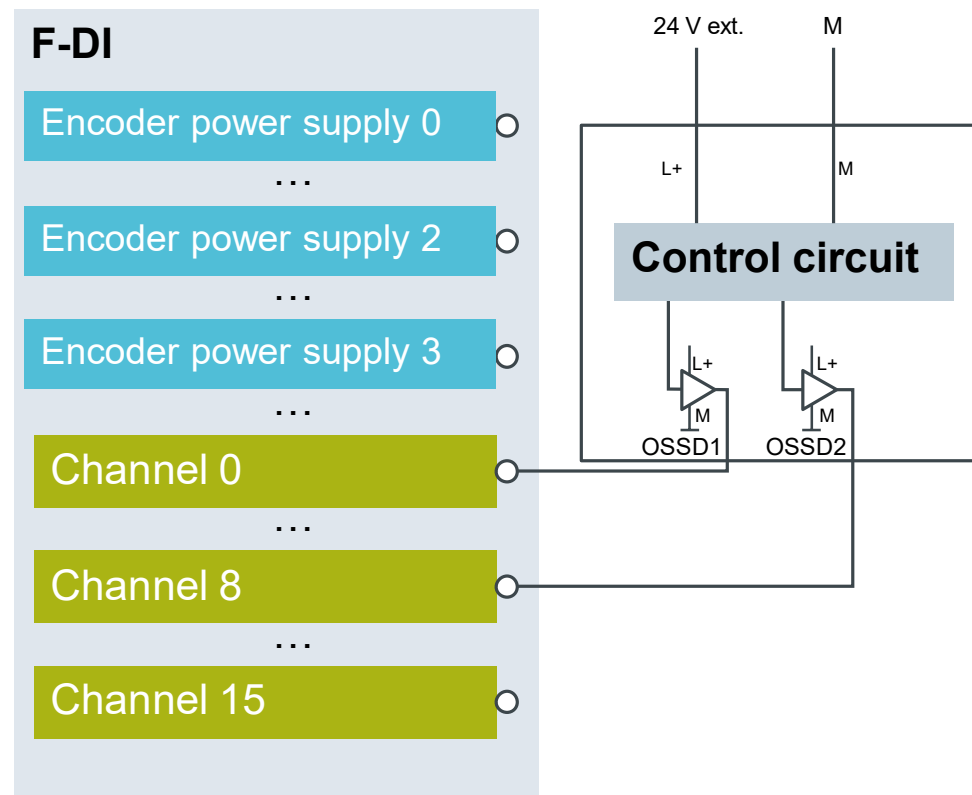

## ET 200MP – Fail-safe digital output module F-DQ 8x24VDC/2A PPM

### Properties

- Central/distributed application
- 8 fail-safe digital outputs 2A (PM-or PP-switching) up to SIL 3/PL e
- Open circuit/overload monitoring
- Cross circuit monitoring
- Module passivation in fault scenario
- "RIOforFA-Safety" profile is supported
- Width: 35 mm

**SIEMENS**  
*Ingenuity for life*



# ET 200MP – F-DQ 8x24VDC/2A PPM – interconnection possibilities



## Two-channel contactor control PM-switching

### Module diagnostics

- Short circuit P to L+
- Cross circuit monitoring P-... to P
- Missing supply

→ High diagnostics (up to SIL 3/PL e)<sup>1</sup>

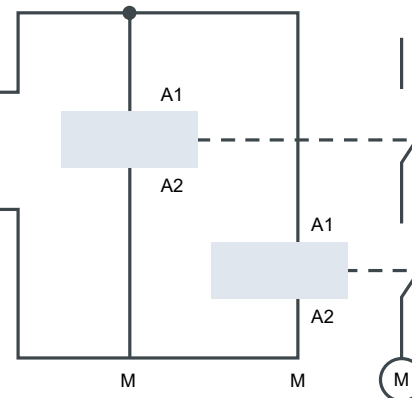

<sup>1</sup> When implementing feedback circuit monitoring (FDBACK block) in the F-user program

# ET 200MP – F-DQ 8x24VDC/2A PPM – interconnection possibilities

**SIEMENS**  
*Ingenuity for life*

## Two-channel contactor control PP-switching

### Module diagnostics

- Short circuit P to L+
- Cross circuit monitoring P-... to P-...
- Open circuit/overload monitoring P-switch

→ High diagnostics (up to SIL 3/PL e)<sup>1</sup>

<sup>1</sup> When implementing feedback circuit monitoring (FDBACK block) in the F-user program

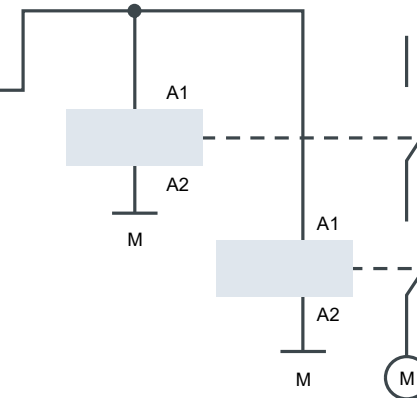

**In the event of a cross circuit between a positive potential (e.g. L+) and DQ-PPn, the activated actuator can no longer be shut down**

## ET 200MP – F-DQ 8x24VDC/2A PPM – dark test

### Dark test



- Test required, permanently activated
- Test signal while channel is active ("1")
- Alternating brief deactivation of P or M and read back of the output channel
- Sufficiently slow actuators do not respond to test signal

#### The dark test detects the following errors

- Internal errors of the P and M switches
- Short circuit, e.g. P0 to L+ or M0 to ground
- Cross circuit, e.g. P0 to P1 or M0 to M1

**SIEMENS**  
*Ingenuity for life*

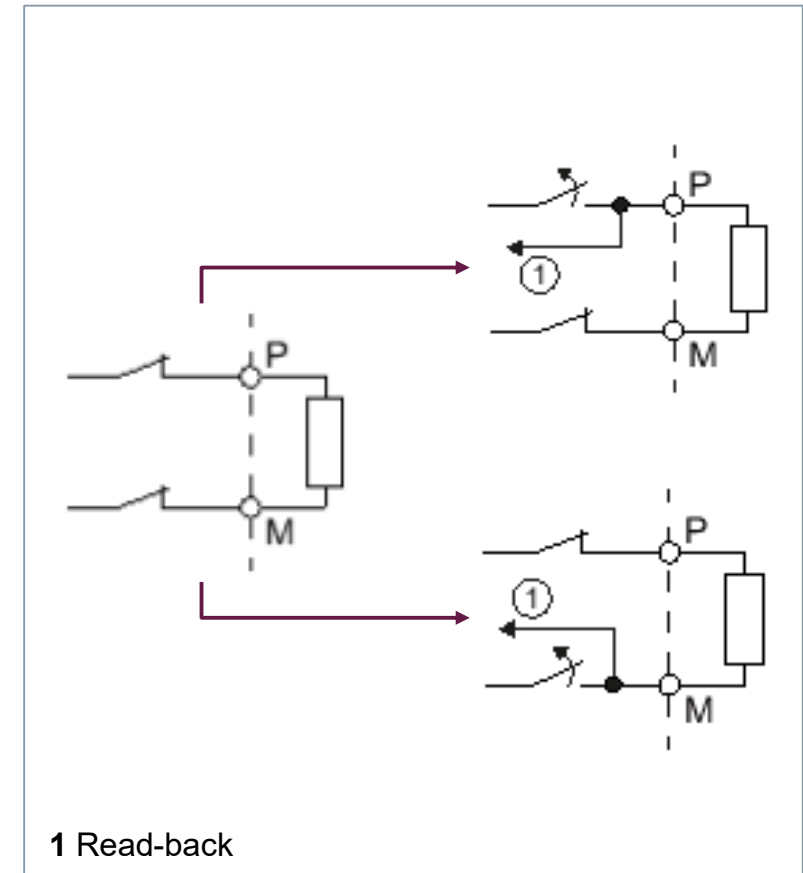

## ET 200MP – F-DQ 8x24VDC/2A PPM – switch-on test

### Switch-on test



- Test required, permanently activated
- Test signal while channel is inactive ("0")
- Alternating brief activation of P or M and read back of the output channel
- Actuator is not activated by the test signal

#### The switch-on test detects the following errors

- Internal errors of the P and M switches
- Short circuit, e.g. P0 to L+ or M0 to ground
- Cross circuit, e.g. P0 to P1 or M0 to M1

**SIEMENS**  
*Ingenuity for life*

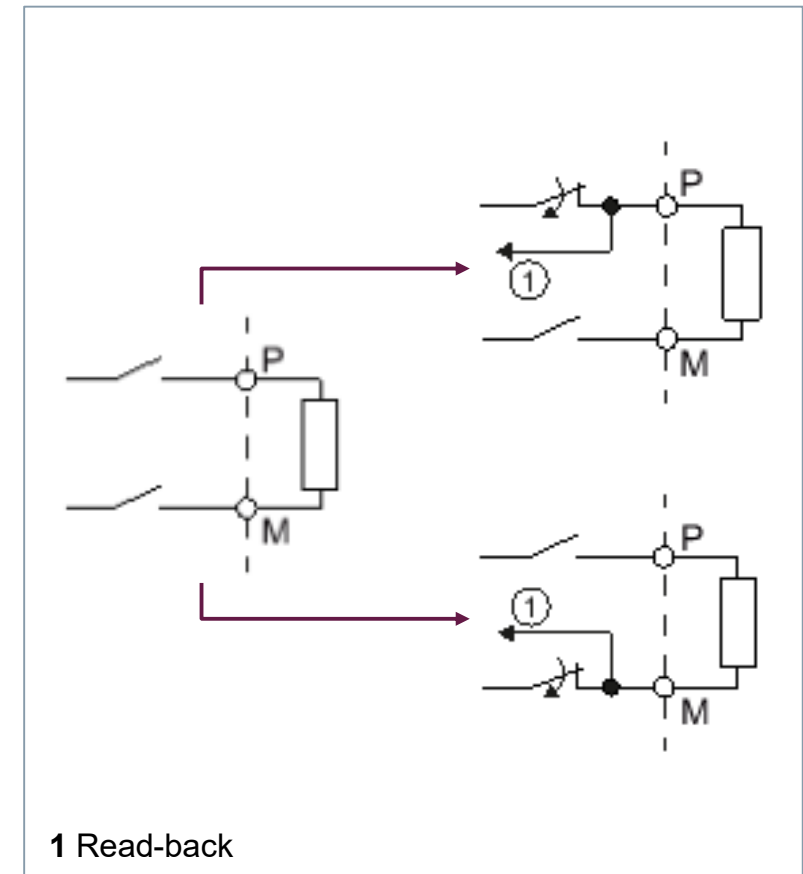

## ET 200MP – F-DQ 8x24VDC/2A PPM – light test

### Light test



- Test optional, to be parameterized by user
- Test signal while channel is inactive ("0")
- Simultaneous brief activation of P or M and read back of the output channel
- Sufficiently slow actuator does not respond to test signal

#### The light test detects the following errors

- Overload with signal "0" at output
- Open circuit with signal "0" at output

**SIEMENS**  
*Ingenuity for life*

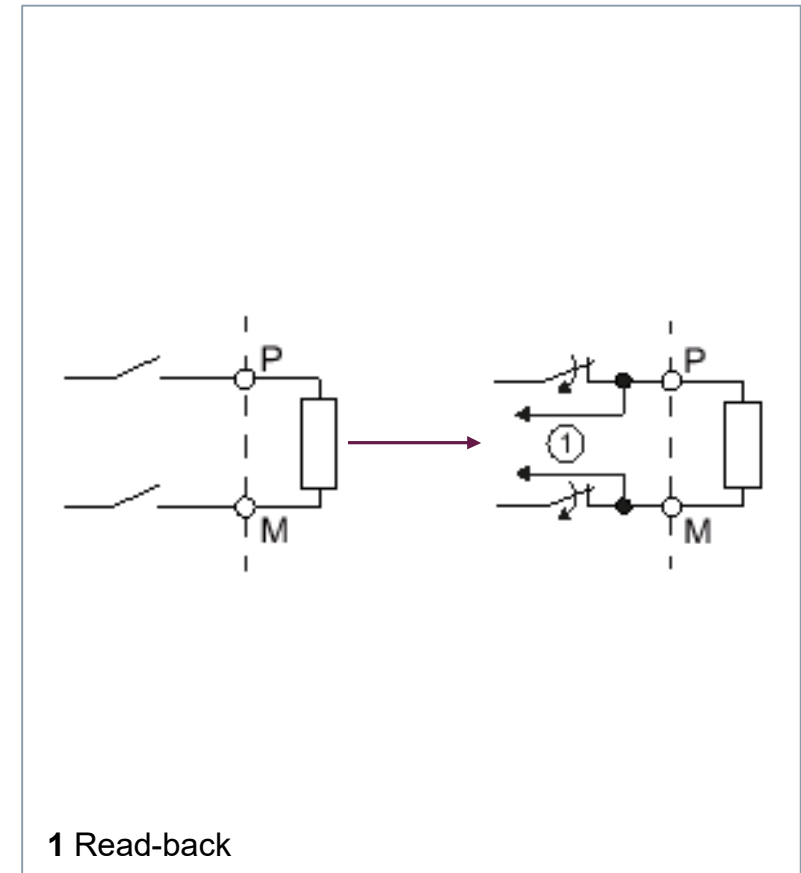

# Agenda

- 1 System overview
- 2 S7-1500 Controller
- 3 ET 200
  - 3.1 IP 20 - ET 200SP
  - 3.2 IP 20 - S7-1500/ ET 200MP
  - 3.3 **IP 65 - ET 200eco PN**
- 4 Module evaluation and addressing
- 5 Application samples and tools

# ET 200eco PN – Block I/O in IP67 with PROFINET connection

**SIEMENS**  
*Ingenuity for life*

## Robust design

- Due to excellent, rugged design and degree of protection up to IP67 for harsh industrial environments, regardless of installation location
- Resistant to vibrations, dust, oil or humidity
- Possible use in space-sensitive areas directly at the machine

## Easy commissioning and expansion

- Easy handling ensures fast commissioning and maintenance
- Flexible expansion of the system via PROFINET possible

## New: Fail-safe digital input/output module

For processing fail-safe digital signals



# ET200eco PN – Fail-safe digital input/output module F-DI 8 x 24VDC, 4xM12/F-DQ 3 x 24 VDC/2 A PM, 3xM12

**SIEMENS**  
*Ingenuity for life*

## Properties

- Direct connection to higher-level controller via PROFINET/Profisafe
- 8 fail-safe digital inputs up to SIL 2/PL d or 4 fail-safe digital inputs up to SIL 3/PL e
- 2 outputs for encoder power supply
- External encoder supply possible
- Integrated diagnostics of the input circuit by means of short circuit and discrepancy evaluation
- 3 fail-safe digital outputs  
P/M-switching up to SIL 3/PL e
- Open circuit/overload/cross circuit monitoring
- Channel or module passivation in event of an error
- "RIOforFA-Safety" profile is supported
- Dimensions: 60 mm x 175 mm x 49 mm (W/H/D)



# Connection of sensors and actuators to ET 200eco PN

## Module diagnostics

- Open circuit monitoring
- Short circuit monitoring
- F-DI 8x 1v1 up to SIL 2/Cat. 3/PL d
- F-DI 4x 2v2 up to SIL 3/Cat. 4/PL e
- F-DQ up to SIL 3/Cat. 4/PL e

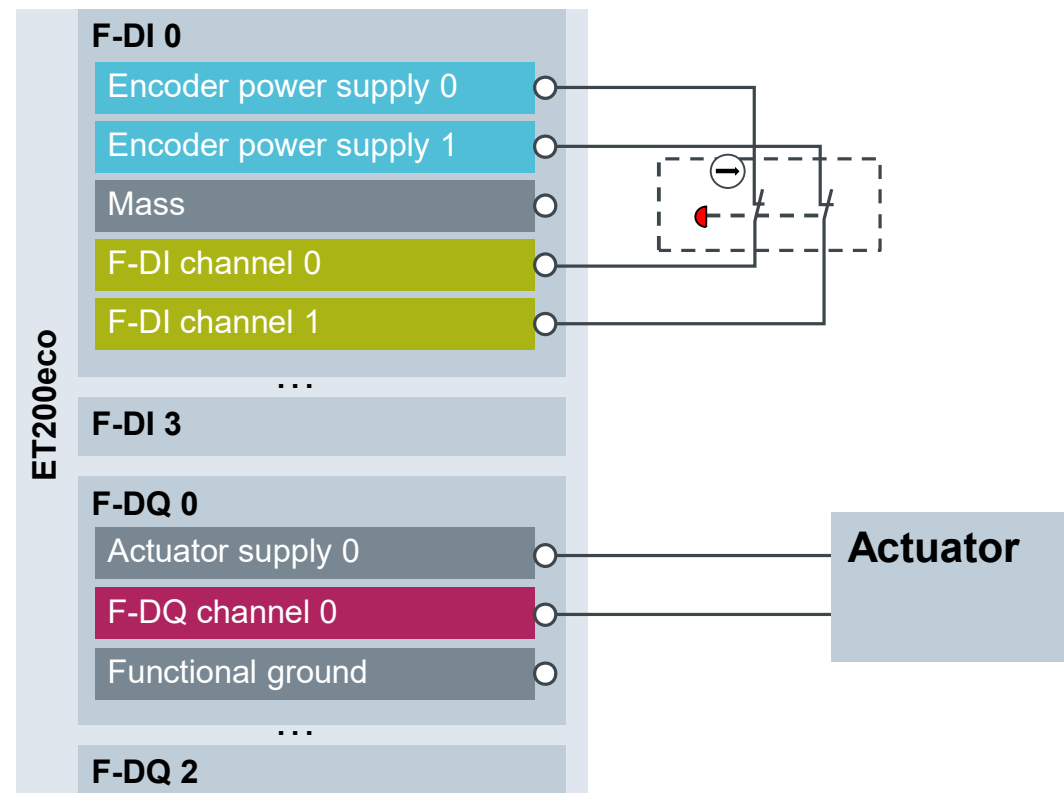



# Agenda



- 1 System overview
- 2 S7-1500 Controller
- 3 ET 200
- 4 **Module evaluation and addressing**
- 5 Application samples and tools

# Module evaluation Passivation/reintegration

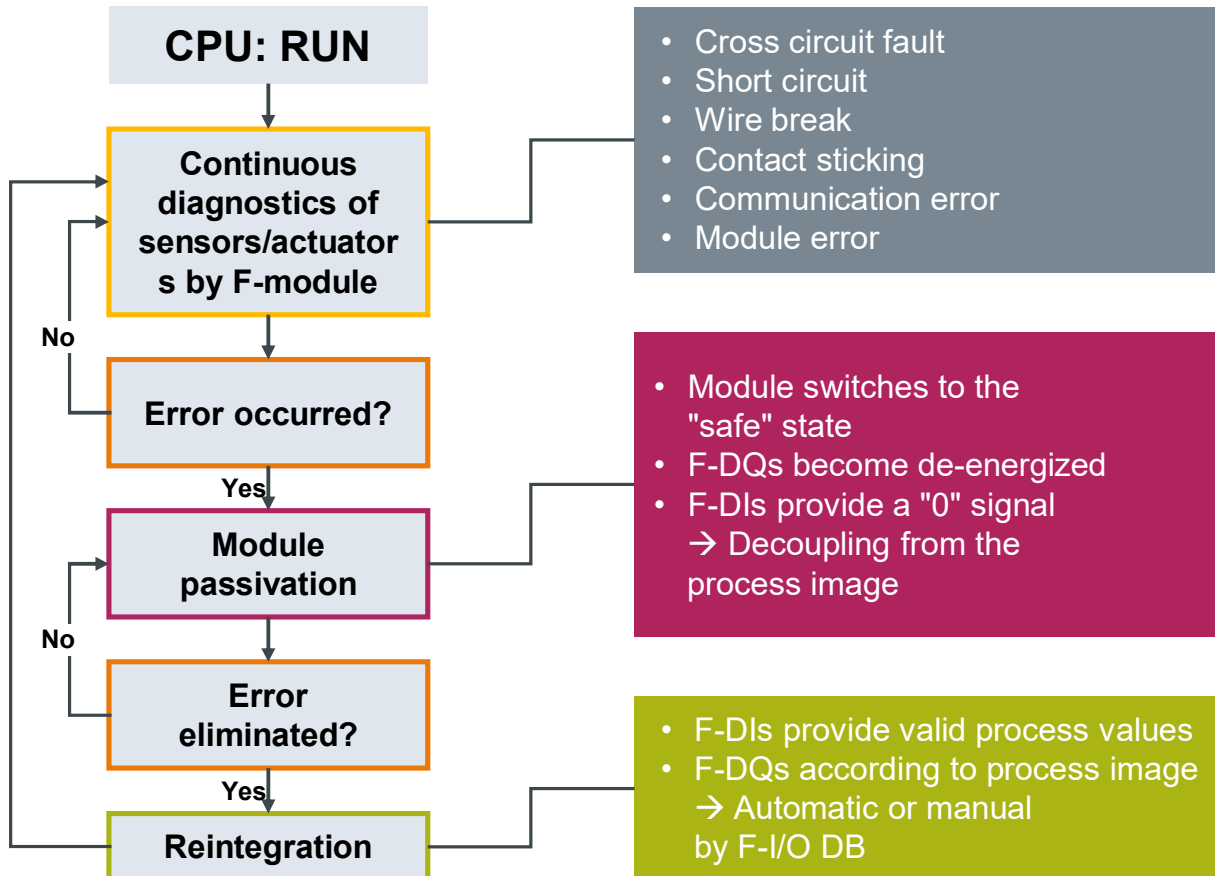



# Unambiguousness of PROFI-safe addresses – PROFI-safe addressing

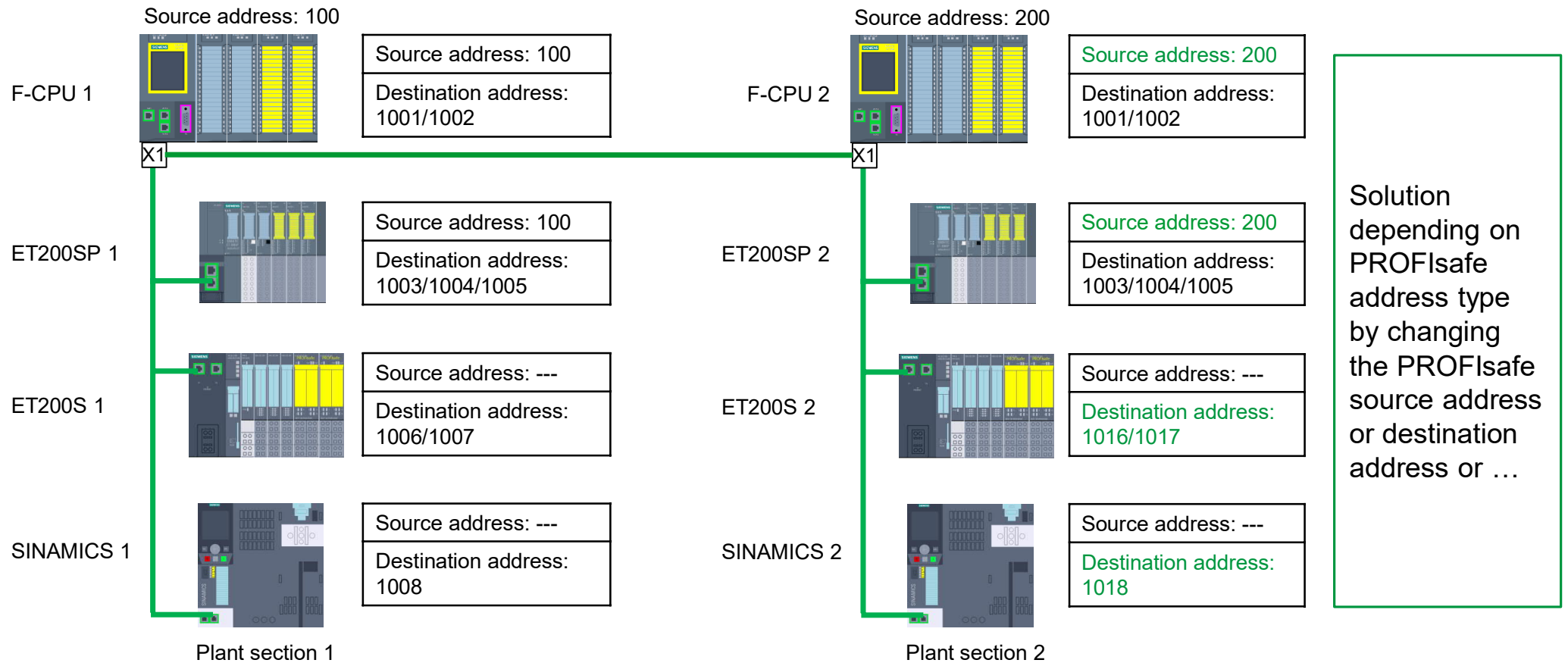

# Unambiguously of PROFI-safe addresses – PROFI-safe addressing

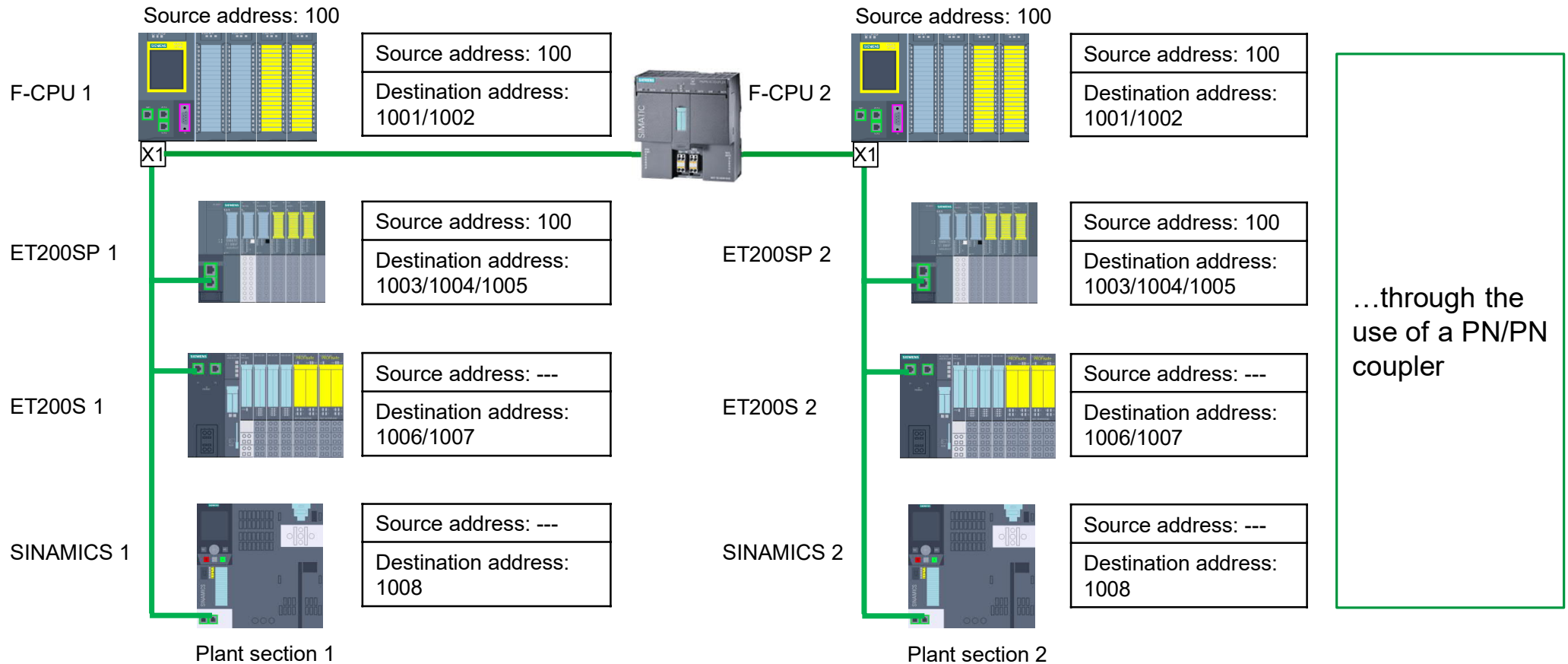

## Unambiguousness of PROFI-safe addresses – Network separation

Network-separating components can be

- PN/PN coupler
- CM for S7-1500
- 2nd interface of the S7-1500
- CP for S7-300 and S7-400

Generally, routers are also network-separating. The user must check, however, whether the forwarding of PROFINET telegrams from the routers can be ruled out

For further information  
see FAQ



# Agenda



- 1 System overview
- 2 S7-1500 Controller
- 3 ET 200
- 4 Module evaluation and addressing
- 5 **Application samples and tools**

## Siemens Evaluation Tool (SET) – the straight path to a safer machine

**SIEMENS**  
*Ingenuity for life*

### Tool for evaluating safety functions of a machine

- Certification of a safe machine with automatic calculation and documentation according to the current standards (IEC 62061 and ISO 13849-1)
- TÜV-tested tool
- Complete the necessary entries in just a few steps
- Quick access to current product data via comprehensive, pre-defined example libraries
- User-friendly archiving: Projects can be saved and called up again as required



Free use of online tool

# SIMATIC Automation Tool (SAT) – Commissioning, maintenance and servicing of SIMATIC devices



**Tool for adapting/servicing the devices in a network without TIA Portal (for S7-1200/1500(F), ET200(F), SCALANCE switches, identification systems RFID)**

- Illustration of the accessible devices and address assignments (IP, subnet, gateway) and station name change (PROFINET device)
- Program download to CPU (F-programs V3.1 or higher) and HMI
- Backup and restore of projects for CPU (F-projects from V3.1) and HMI
- Firmware update of the CPU and connected modules
- Read-out of the CPU diagnostics buffer
- Reset to factory settings (also F-CPU)



Further information on SIMATIC Automation Tool →

# DF FA S SUP application examples in the SIOS – Safety



## Mode selection

Entry ID: [89260861](#)

- These FAQ describe the requirements for a mode selection with standard modules
- They describe the standard-related backgrounds as well as those specified by the machinery directive

## Safety with the S7-1200 FC CPU

Entry ID: [109478932](#)

- For a total of 30 scenarios of protective door and emergency stop applications, you have an F-block at your disposal for the direct use of an S7-1200 FC CPU
- In addition to the use of the S7-1200 FC CPU there is also an explanation of what must be considered for reaching a specific PL/SIL

## SLS specification via HMI

Entry ID: [67634251](#)

- This application example supports you when creating a safety-oriented input function for setpoint values for a drive via an HMI system
- It provides you with a safety concept, which you can use to solve the task described above up to SIL 2 according to IEC 62061 or PL d according to ISO 13849-1

## Safety Integrated programming guideline

Entry ID: [109750255](#)

- Supplement to the program guidelines for S7-1200/1500 controllers, with safety-specific information
- You will gain many advantages if you adhere to the recommendations cited here
  - Reusability of program components
  - Easier acceptance (code review, error detection and correction)
  - Reduction of programming errors

## PROFIsafe address assignment

Entry ID: [109740240](#)

In various system configurations, there are different requirements for the network-wide and CPU-wide unambiguity of PROFIsafe addresses. This document explains the requirements based on example configurations

## Configuration control with safety

Entry ID: [109481852](#)

- This application example describes how F-modules behave when configuration control is used
- It explains which procedure is needed for using this functionality

Thank you!

**SIEMENS**  
*Ingenuity for life*



Subject to modifications and errors. The information provided in this document contains merely general descriptions or characteristics of performance which in case of actual use do not always apply as described or which may change as a result of further development of the products. An obligation to provide the respective characteristics shall only exist if expressly agreed in the terms of contract.

All product names can include registered trademarks or other rights of the Siemens group or third parties, the unauthorized use of which may infringe the rights of the owner.

[siemens.com/simatic-safety](https://www.siemens.com/simatic-safety)

# Questions and Answers

**SIEMENS**  
*Ingenuity for life*



[www.siemens.rs](http://www.siemens.rs) > DI Webinar



**Hvala na pažnji!**

**SIEMENS**  
*Ingenuity for life*

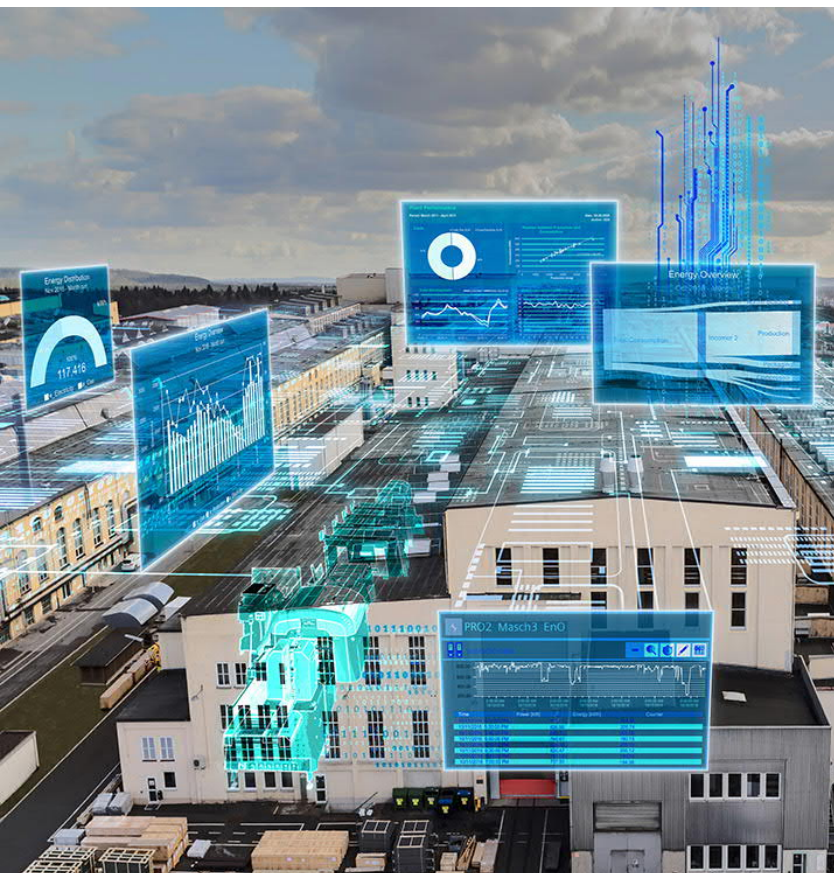

**Darko Živković**

Sales Engineer

Siemens doo Beograd, Digital industries

Omladinskih brigada 90v

11070 Beograd

Tel: +381 60 8170 367

Email: [darko.zivkovic@siemens.com](mailto:darko.zivkovic@siemens.com)

[siemens.com/simatic-safety](https://www.siemens.com/simatic-safety)