

Introduction to HVDC Architecture and Solutions for Control and Protection

Valentin Gabor Csutar, Sreenivasa Kallikuppa and Lin Charles

ABSTRACT

This application report provides an introduction to the High Voltage Direct Current (HVDC) power transmission architecture and solutions for control and protection.

Contents

1	HVDC Power Transmission Overview and Architecture	2
2	HVDC Transmission System (HVDC station)	4
3	HVDC transmission station - Control and Protection (C and P)	8
4	HVDC Transmission Control and Protection – System Level Block Diagram	12
5	TI Solutions for HVDC Transmission Station Control and Protection	13
6	Summary	15
7	TI Reference Designs	16
8	Additional References	16

List of Figures

1	HVDC Power Transmission Station	3
2	Cost Comparison of HVAC and HVDC Power Transmission	4
3	HVDC Transmission Station Overview	4
4	HVDC Station Key Components	5
5	HVDC Transmission Station – Control and Protection	8
6	HVDC Control and Protection System Block Diagram	12
7	HVDC Transmission Control and Protection – TI Solutions	13

List of Tables

1	Comparison of HVDC and HVAC.....	2
2	HVDC Converter Switching Element Summary	6
3	HVDC Station Modules Description.....	12

Trademarks

All trademarks are the property of their respective owners.

1 HVDC Power Transmission Overview and Architecture

This document provides an overview of the high voltage direct current (HVDC) power transmission and the advantages of using HVDC compared to high voltage alternating current (HVAC). This application report focuses on the control and protection requirements of HVDC station, products and solutions that can be leveraged during control and protection system design.

1.1 Electrical Power - Generation, Transmission and Distribution

Electricity is produced by large power plants and is then carried over long distances (> 100 km) at high voltages (110 kV or more) by the transmission lines, which is stepped down to the level of the distribution network (11 kV or 415 V), bringing electric power to the consumer. Most power plants generate electricity as AC and the entire system uses AC afterwards since the voltage can be stepped up or down easily by the use of transformers. Bulk power from the generation plant is transported to consumers using transmission lines operating at high voltages. For shorter distance transmission of power (< 100 km), AC transmissions are widely preferred. When the transmission distances are longer (> 500 km), limitations are seen in using AC transmission.

1.2 HVAC to HVDC Power Transmission

The electrical supply demand is increasing globally. Power plants are often located near to energy sources, to minimize costs and environmental effects. These power plants often are located away from heavily populated areas or cities, therefore, transporting the electricity generated economically and efficiently is important. This is accomplished by transmitting the generated power at a high voltage. High-voltage (HVAC) is preferred for transmission purposes mainly because higher voltages are easily achievable by means of a transformer (stepping up at the power plant and stepping down at the substation).

To meet the growing demand, utilities are looking at improving the system performance by interconnecting the grid to balance the load and looking at using newer technologies (HVDC or Flexible AC Transmission Systems FACTS) for improving efficiency. The advantages of HVAC is simpler voltage transformation and easier current interruption. In some cases, it is not possible to use HVAC transmission technology, when long transmission lines (> 500 km) are involved due to voltage instability and higher transmission losses. The disadvantage of HVAC is limitations on long distance transmission, current carrying capacity, reactive power (need reactive power compensation at different locations along the transmission lines) loss, skin effect (non-uniform current distribution in conductors carrying, where most of the current is found in the conductor's outer layers increasing effective resistance) and the Ferranti (received voltage higher than the transmitted voltage) effect. Using HVDC for transmitting power over long distances is the solution.

1.2.1 Comparison of HVDC and HVAC

Table 1 provides a comparison between DC and AC for critical parameters that influence the decision for setting up new HVDC station.

Table 1. Comparison of HVDC and HVAC

Parameters	HVDC	HVAC
Type of transmission	DC	AC
Application	HV Power transmission	HV/MV power transmission
Transmitted power and distance	Independent of distance, no limit	Depends on the distance, needs intermediate substations
Losses	Lower	Higher
Cost of Transmission (Conductors and poles)	Low cost: only two conductors are used for transmission and DC cables are cheaper than AC cables.	High cost of transmission
Cost of equipment	Higher	Lower
Station design complexity	Higher	Lower

Some of the key advantages and disadvantages of HVDC transmission include:

- Advantages
 - Cheaper for bulk power transmission and more power can be transmitted per conductor per circuit
 - No skin effect and voltage stability problem
 - Asynchronous interconnection possible
 - Lower short circuit fault levels and fast fault clearing time
- Disadvantages of HVDC
 - Expensive convertors
 - Generation of harmonics and reactive power requirement
 - Difficulty of circuit breaking

1.2.2 Primary Objectives of HVDC Transmission

HVDC transmission is used for improving the power transmission efficiency and enhancing the interconnection of asynchronous grids. The primary objective of using HVDC transmission is summarized below:

- Bulk power transmission: Transmit bulk power from one point to another point over long distances (> 500 km for overhead lines).
- Connect asynchronous systems: allows transfer of power between grid systems running at different frequencies is improving stability and economy of each grid.
- Off-shore wind farm integration: simplifies bulk power transfer from off-shore wind farms to large load consumption centers.
- Back-to-back HVDC system: rectification and inversion takes place at the same station with very small DC line

1.3 Working Principle of HVDC Transmission Station

In the HVDC station, the converter transformer steps-up the generated AC voltages to the required level. The converter station takes the electric power from the three-phase AC network and rectifies it to DC, which is then transmitted through overhead lines (or cables). At the receiving end of the converter station, an inverter converts the DC voltage back to AC, which is stepped down to the distribution voltage levels at various consumer ends. [Figure 1](#) illustrates the power transmission process. This technology is suitable for transmitting rated power range between 100-10,000MW.

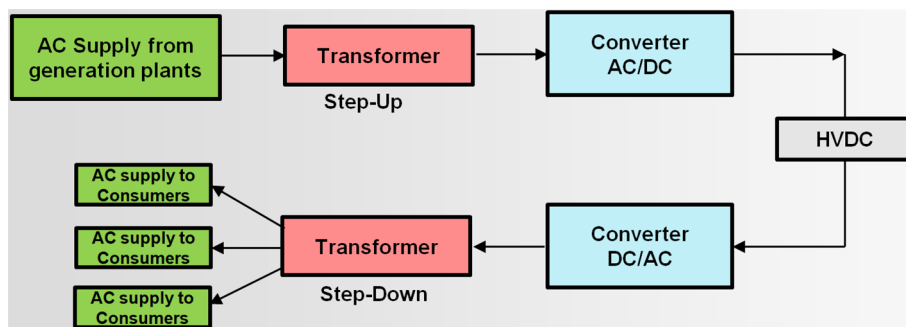

Figure 1. HVDC Power Transmission Station

1.4 Advantages of HVDC Transmission

Use of HVDC reduces cost and also results in lower losses (5-6% against 8-10% for HVAC). Other advantages over HVAC includes stability, controllability, and so forth. For distances longer than the break-even distance, HVDC system becomes more cost effective as shown in Figure 2.

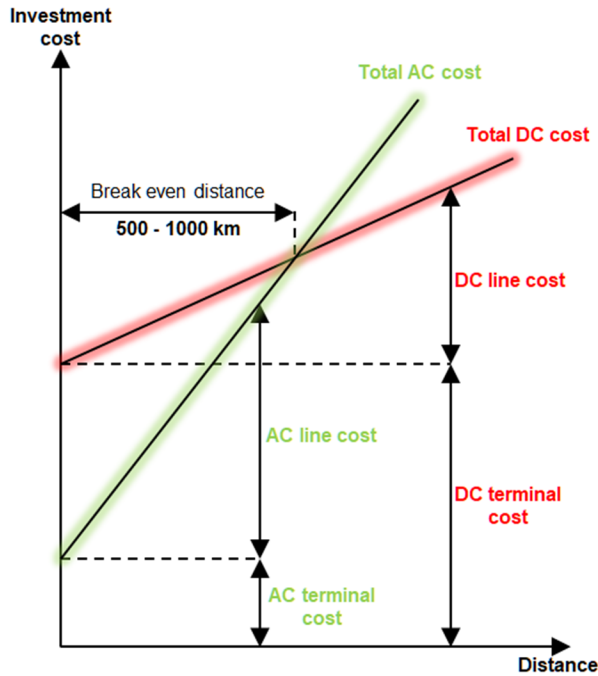

Figure 2. Cost Comparison of HVAC and HVDC Power Transmission

2 HVDC Transmission System (HVDC station)

The HVDC system uses DC for power transmission over a long distance. HVDC transmission system is classified into the following functional blocks as shown in Figure 3.

- Converter transformer to step up the AC voltage
- Converter station for AC to DC conversion (rectifier)
- DC Transmission lines
- Converter station to convert (overhead or underground) back DC to AC (inverter)
- Converter Transformer to stepdown the AC voltage

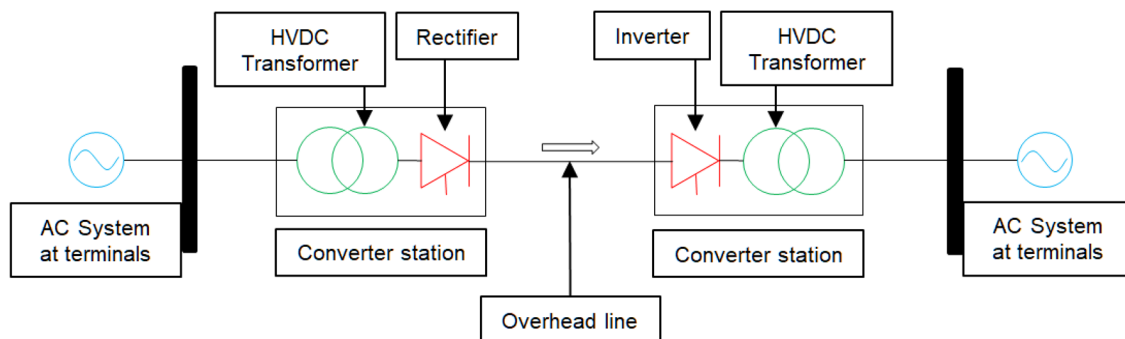

Figure 3. HVDC Transmission Station Overview

2.1 HVDC Transmission Technologies

To utilize DC, a conversion step is necessary. In order to convert high voltage AC power to DC power, two technologies are available, classical Line Commutated Converter (LCC) and the Voltage Source Converter (VSC). LCC is commonly called as HVDC Classic, while VSC has a several names, like HVDC Light (ABB), HVDC Plus (Siemens), HVDC MaxSine (Alstom) and Flexible HVDC (China).

LCC converter technology is based on a semiconductor-based switch named thyristor. Thyristors need to be turned on, or fired, to start conducting current. These switches can withstand the AC voltage in either polarity but current can only flow in one direction and can be limited by adjusting the time the thyristors are turned on. This time, or angle in a sinusoid, at which the thyristors are turned on is called the firing angle, or valve ignition delay angle, and is used to control power flow between the HVDC stations.

Voltage Source Converter technology is based on Insular Gate Bipolar Transistors (IGBT). The IGBT can be controlled both with regards to being turned on or off. In VSC technology, the DC current can flow in both directions. That is a benefit over the LCC technology in which the current can flow in one direction. Considering the bi-directional capability of the DC current flow in VSC, there is no need to change the DC voltage polarity of the converters to change the power flow direction between converters. Compared to LCC technology, it is possible for VSC to be connected to weak grids that has low short-circuited level.

In VSC based HVDC, Power can be controlled by changing the phase angle of the converter AC voltage with respect to the filter bus voltage, whereas the reactive power can be controlled by changing the magnitude of the fundamental component of the converter AC voltage with respect to the filter bus voltage. By controlling these two aspects of the converter voltage, operation in all four quadrants is possible.

2.2 HVDC Transmission System (HVDC station) Key Components

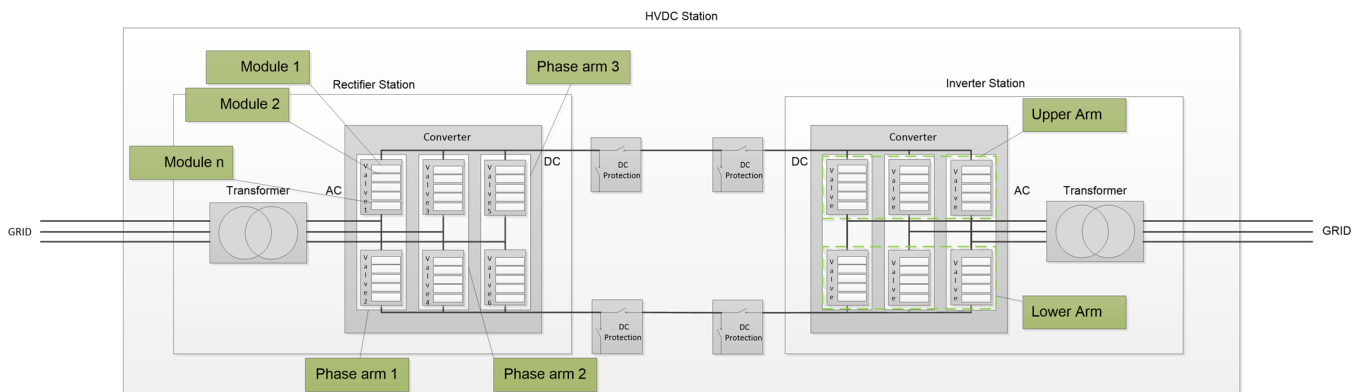

Figure 4. HVDC Station Key Components

The main components of HVDC transmission system taking into account the used conversion technique, the rated DC voltage and the power ratings are:

- Converter
- Converter transformer including TAP controller
- Power transmission lines, overhead lines or underground cables
- Harmonics reduction and waveform shaping
- Protection equipment

2.2.1 Converter

Converter is the heart of the HVDC system and performs AC/DC and DC/AC conversion. Each HVDC system has two converters one at each end. The converter at transmitting end act as a rectifier and the converter at the receiving end act as an inverter. Based on the HVDC technology the converter can be based on IGBT or Thyristor switching elements.

The converters typically constitute of one or more IGBT/thyristor bridges where each bridge consists of six IGBT/thyristor valve arms, which is based on the system's voltage and power rating contain numerous individual IGBT/thyristors. For achieving higher voltages and currents, switching devices (IGBT or thyristors) are connected in parallel and series. For higher voltages, switching devices are connected in Series and for higher currents switching devices are connected in Parallel. Commonly used HVDC configurations include monopolar and bipolar links and the number of converters in a HVDC station depends on the configuration.

2.2.2 Converter Valve Arms

Valves have modular design and consists of modern light triggered thyristors as today's 500 kV thyristor valves. Individual thyristor modules will be arranged in valve towers. Double valve tower or quadruple valve tower are possible solutions depending on the valve hall and transformer arrangement. For UHVDC application double valve towers seem to be more adequate due to large clearance requirements inside the valve halls.

The valve arm contains a number of switching elements connected in series (or parallel). Based on LCC or VSC is the converter topology, the switching element could be thyristor or IGBT. The number of the switching elements depends on the voltage level of the HVDC station.

- Thyristor LCC valves: The thyristor valves can be build-up in different ways depending on the application and manufacturer. However, the most common way of arranging the thyristor valves is in a twelve-pulse group with three quadruple valves. Each single thyristor valve consists of a certain amount of series connected thyristors with their auxiliary circuits. All communication between the control equipment and each thyristor at high potential, is done with fibre optics.
- IGBT VSC valves: The VSC converter consists of a two level or a multilevel converter, phase-reactors and AC filters. Each single valve in the converter bridge is built up with a certain number of series connected IGBTs together with their auxiliary electronics. VSC valves, control equipment and cooling equipment would be in enclosures (such as standard shipping containers) that make transport and installation very easy. All modern HVDC valves are water-cooled and air insulated.

2.2.2.1 Converter Phase Arms

The phase arm of the converter is consists of two valve arms (upper and lower arms), which are connected to the input or output of the AC supply converter transformer. Each phase has two arms. AC is transmitted along the grid in three phase configuration. A three phase converter has three phase arms consisting of 6 valves. [Table 2](#) illustrates number of switching elements required for a 200 kV HVDC converter.

Table 2. HVDC Converter Switching Element Summary

Converter Type	Switching Element	Voltage Rating kV	HVDC Voltage Rating kV	Number of Valve Arms	Approximate Number of Switching Elements per Valve	Approximate Number of Switching Elements per Converter
LCC	Thyristor	6.5	200	12	35	420
VSC	VSC	1.5	200	6	135	810

Table 2 shows indicative calculations for understanding HVDC system complexity, number of devices that are interconnected to build a valve/converter and are for a 200-250 MW power transmission system using 200 kV voltage level. Depending on the voltage rating, IGBT/Thyristors are connected in series and depending on the current rating; IGBT/Thyristors are connected in parallel.

2.2.3 Converter Transformers

The converter transformers transform the voltage of the AC busbar to the required entry voltage of the converter. The transformer is an interface between AC side and DC side. The main insulation, therefore, is stressed by both the AC voltage and the DC voltage potential between valve-side winding and ground. These are special types of transformers that are designed to withstand high harmonics currents and voltage stress. Also, they will have tap changers to enable the optimization of HVDC operations. Converter transformers act as galvanic barrier between AC and DC systems to prevent DC potential entering into the AC system. Availability of the HVDC transmission is dependent on the converter transformer performance.

In HVDC transmission there is requirement for large voltage control at the converter & inverter ends. Converter transformer typically includes an on-load tap-changer to assist with voltage regulation. Tapping range is large (25 ~ 30%) with small steps to give necessary adjustments in supply voltage. On-load tap-changers (OLTCs) are used for changing the transformer winding ratio to control the firing angle and to compensate voltage variations. OLTCs are used to control the DC output voltage when the converter is used as rectifier and AC voltage to the grid when the converter is used as an inverter. The transformer tap ratio can be manipulated to help prevent the converter from becoming over or under-modulated. Operating the converter in the over or under-modulated region could have a negative impact on harmonic performance.

2.2.4 Power Transmission Lines

Transmission lines can be overhead lines and underground (or undersea) cables. Overhead lines are more common and generally less expensive.

Conductors are suspended overhead from towers and poles and are generally not insulated. Some of the challenges with overhead cables include line tension, sag, heating due to over loading and change in loading capacity due to varying environment. Cables are always insulated and are generally used in underground applications. Underground cables are used in applications where overhead lines are hard to locate, such as water crossings, and are increasingly considered advantageous for their resilience to wind and ice storms.

2.2.5 Components for Ripple Control, Harmonic Control and Waveform Shaping

In addition to rectification and inversion, voltage regulation, control of harmonics, reactive power compensation and wave shaping is required for ensuring the HVDC station operates reliably meeting operational requirements and providing the required power output. Some of the equipments connected include:

- Smoothing reactors
It is a coil connected to DC line that reduces ripple and harmonics in DC link, Limits over current during faults, Prevent current from being discontinuous for light loads and also helps to prevent from commutation failure.
- Harmonic filters
Converters generate harmonics in voltages and currents. These harmonics may cause overheating of capacitors and nearby generators and interference with telecommunication systems. Harmonic filters are used to mitigate these harmonics.
- Reactive power supply
Under steady state condition, the reactive power drawn by the converter is about 10-50% of the active power transferred and is provided by the shunt capacitor bank.
- Earthing Electrodes
Electrodes are conductors that provide connection to the earth. They have large surface to minimize current densities and surface voltage gradients.

2.2.6 Protection Equipment

For the safety of the operator during preventive maintenance activities and equipment service, a number of protective equipment including disconnecting switch or disconnector connected in series with the HVDC lines, grounding switch and AC/DC circuit breakers are provided.

3 HVDC transmission station - Control and Protection (C and P)

Each HVDC converter station is equipped with a control and protection system designed to operate satisfactorily under normal as well as abnormal conditions. The control system is designed to be self-protecting, efficient, has stable operation and provides maximum power control flexibility without compromising the system safety. HVDC C and P additionally ensures there are no harmful interactions between the HVDC transmission system and the AC network that may adversely affect the HVDC converter or AC network protection system or users of the transmission system. The control and protection system for both the converters (rectifier and inverter) is designed to be identical as much as possible.

The C and P system is designed to have full redundancy for all the vital systems and includes measuring, processing, switching, indicating and communicating systems. Converter control achieves the desired power transmission and AC bus voltage magnitude coupled with automatic switching of filters, capacitor and reactor banks. The open/close commands to the high voltage devices are interlocked in the controls to prevent out of-step operation of breakers, disconnectors and ground switches. Also interlocks to prevent forbidden system or switchyard configurations are installed. Interlocking to prevent personnel access to the valve hall and filter, areas that are not walk through, is provided by means of interlocks controlled by the Station Controls. [Figure 5](#) provides an overview of the control and protections used in an HVDC station.

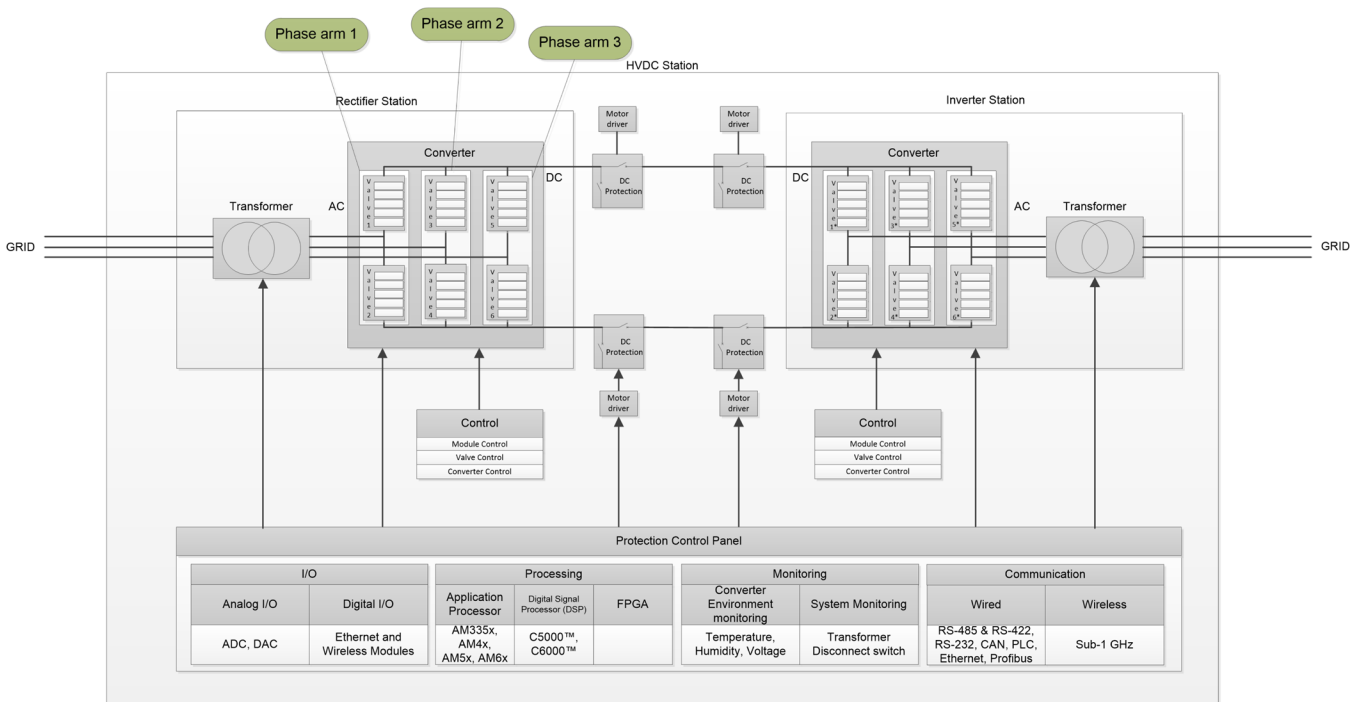

Figure 5. HVDC Transmission Station – Control and Protection

3.1 Control OF HVDC Transmission Station

The major advantage of a HVDC link is rapid controllability of transmitted power through the control of the converters. Modern converter controls are not only fast, but also very reliable and they are used for protection against line and converter faults. The control system is structured in an hierarchical manner as discussed in [Section 3.1.1](#).

3.1.1 System Control

The system function mainly includes the supervisory control and data acquisition (SCADA) functions listed below:

- Controls, indication and alarms
- Time synchronization and interlocking
- Sequential isolation using disconnect switch
- Voltage selection, resonance and phase detection
- Instrument transformer supervision
- Interface to special protection and operational tripping schemes
- Communications using standard grid protocols including IEC61850, IEC60870-5-101, IEC60870-5-104
- Metering including AC/DC voltage/current, active/reactive power, harmonics and other parameters
- Transient fault recording and cable monitoring
- Converter cooling and valve hall fire detection
- Auxiliary power supply and power supply supervision

3.1.2 Master Control

Only one converter station shall have the active control of the HVDC transmission system at a time and is called the master station. The master station performs the dispatch controls as listed below:

- Converter control modes including constant active power, reactive power and voltage control
- Start-up and shutdown of HVDC transmission
- Frequency control
- Power ramping and power reversal
- Emergency power control/power demand override
- Reactive compensation and harmonic filter control
- Change over mechanism
- Automatic pole switch

3.1.3 Station Control

The Station Control manages the equipment that is necessary to integrate the HVDC System into the customer's power system and also those functions common to both poles. The main Station Control functions are:

- AC and DC Switchyard Control
- Active and Reactive power control
- AC voltage control
- On-Load transformer tap changer control
- DC current and voltage control
- Stability, Operational states and switching sequence control
- Valve firing control

3.1.4 Pole or Converter Control

The Pole Controls are the heart of the HVDC control system. The DC power flow is controlled to the operator's set point. Steady-state and dynamic performance of the AC systems is also enhanced by the Pole Controls. Features such as power swing stabilization, frequency limit control and sub synchronous resonance damping are some of the available features. The primary function of the Pole Control System is to maintain the transmitted power at the operator selected value. This is achieved with an optimal response during system disturbances and is robust and stable for all system configurations. During normal undisturbed operation, DC current control is active at the Rectifier and DC voltage control at the Inverter.

A backup extinction angle control provides a safety margin to minimize commutation failures at the Inverter following disturbances in its AC system. An Inverter current control function becomes active should the Rectifier station be unable to provide the ordered DC current during AC System disturbances. Converter control coordinates the conversion of current order to a firing angle order or PWM duty cycle, tap changer control and other protection sequences.

3.1.5 Valve Base Control VBC (valve unit control)

The VBC has the functions to control the circulating current and capacitor voltage, to protect converter valves and to monitor converter valves. The valve control receives commands and signals from the pole (converter) control to control/monitors the conduction of power electronic devices within the valves. The key function is Interfacing the converter control system to many (hundreds or more) of the individual power electronics modules within the HVDC power converter. The Valve Base Electronics (VBE) communicates with a large number of power electronics modules using an industry standard passive optical communication technology that allows each module to be controlled and monitored in a tightly-synchronized, time-critical and reliable manner while minimizing the number of fibers needed without compromising redundancy. Some of the functions handled by VBC includes modulating reference voltage of bridge arm based on command received from converter control, Current balance control including the circulating current between upper and lower bridge arms and between different phases, Voltage balance control by calculating the right number of working submodules (SMs) ensuring the capacitors' voltages within a reasonable range, Valve and bridge arm protection and monitoring.

3.2 HVDC Transmission Station Protection

The Converter Protection detects faults on the converter transformer secondary side, in the valve hall and failures that lead to overstress of the valves. The converter station and protection systems are designed such a way that the ac protection of the converter and adjacent ac substation are not affected by the normal, transient and dynamic behavior of the DC system.

The protection and control system of the HVDC converter station is designed to ensure that no single failure of the equipment shall cause total failure of the HVDC system. The HVDC facility is divided into a number of separately protected and overlapping zones. The protection equipment shall only act upon a specific type of fault within a designated zone and shall be stable to other types of disturbances or faults external to the relevant zone. Every protection zone is protected by two main and a backup protection function using different protection principle where ever possible. When different protection principles cannot be used, duplicated protection systems are used. The protection is independent of control as much as possible. The protection systems shall always remain active and shall be powered by separate and independent supplies.

The protection system consists of a completely redundant protection scheme incorporating the following functions:

3.2.1 Protection of AC Section of HVDC Station

The AC protection zones in HVDC station includes:

- AC busbar and line zone protection
- AC filter zone protection
- Converter transformer zone protection

3.2.2 Protection of DC Section of HVDC Station

The DC protection zones in HVDC station includes:

- Valve and ancillary system protection
- DC converter/pole zone protection
- HVDC transmission link/busbar zone protection
- DC smoothing filter, Harmonic filter and Grounding switch zone protection
- Circuit breaker fail protection

3.2.3 Equipment Protection and Monitoring

Additional equipments used in HVDC station include:

- Converter transformer dissolved gas in oil (DGA) and temperature monitoring
- Converter transformer TAP controller
- Converter cooling system
- Capacitor bank
- Valve partial discharge
- Auxiliary supply battery backup

A change over logic is implemented for the redundant systems to ensure seamless transition without loss of protection functions during the HVDC station operation.

The protection for HVDC converter station comprises of protection solutions for AC busbar(s), harmonic filters, converter transformers, poles/converters as well as DC neutral and DC filter(s). The protections detect and clear faulty equipment on the HVAC as well as HVDC system. The protections use the analog inputs including currents and voltages from the field level. Trip commands are sent to the respective breakers and alarms are generated in the HMIs Sequence-of-Events Recorder.

3.2.4 Sampling and DC Fault Detection

Sampling required for HVDC applications as per IEC61869-9 standard is 96,000 Hz. Typically the fault detection is designed to be 2 μ s that translates to 500,000 Hz sampling. Alternatively high speed comparators can be used for fast fault detection.

3.3 Fault Recording and Monitoring

Fault recorder is provided for both AC and DC systems within a converter station. The transient fault recorder (TFR) is integrated as a part of the control and protection of HVDC station. The TFR monitors the power systems continuously and provides an alarm during out of range condition and also records the events for off line analysis.

3.4 Control and Protection Panel

All the control and protection equipment are housed in a centralized control panel and fiber optic interface is used for communicating between the panel and the HVDC system. The required redundancy and the changeover logic are implemented within the C and P panel.

3.5 Diagnostics and Monitoring

Partial discharge of the converters and other equipments connected within the HVDC station is monitored to perform predictive diagnostics. Conductor temperature monitoring to enable dynamic line rating and diagnostics is measured using fiber optic based distributed temperature sensing DTS. HVDC station environment monitoring is provided for deicing and dynamic load management.

4 HVDC Transmission Control and Protection – System Level Block Diagram

Figure 6 shows the control and protection block diagram for an HVDC station. Many of the equipment is placed within the control panel and some of the are placed close to the equipment being protected.

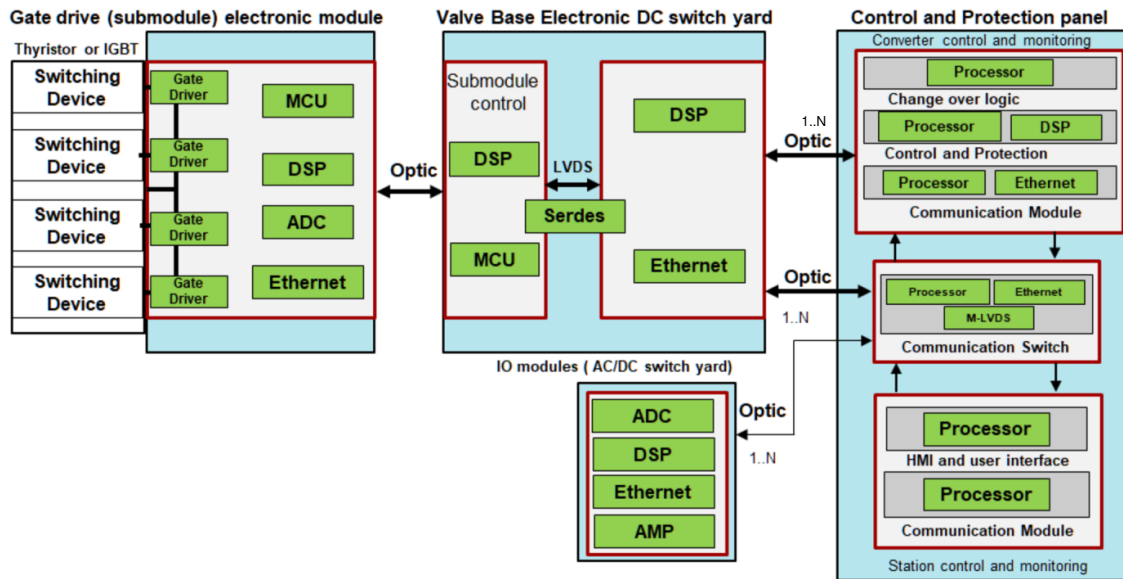

Figure 6. HVDC Control and Protection System Block Diagram

Within the HVDC stations and the control panel, the following modules are interconnected to perform the required protection and control functions

Table 3. HVDC Station Modules Description

Modules	Application	Location
Gate drive	Drives the Thyristor or IGBT module. Implements logic for gate drive, temperature and voltage measurement. Also called as submodules	Each IGBT or thyristor sub module has an associated gate drive unit. The number of gate drive boards depends on the converter voltage and power rating.
Valve control	A number of submodules are connected in series as a valve. Valve control electronics is used to provide command to the gate drive board control.	Each valve may contain one or more valve control electronics depending on the HVDC rating.
Converter and pole control	A converter bridge consists of 6 or more valves. The converter control computes the required electrical parameters and provides the required control command to the valve control. Pole control manages the grid AC voltage to maintain the configured DC output voltage.	The converter and pole control electronics is part of the control and protection panel. Multiple digital signal processing modules are integrated as converter and pole control module. Redundancy is provided to improve performance and enhance reliability.
Station level control and protection	Controls harmonics and reactive power by controlling the capacitor banks and filters. Protects the HVDC station during normal and abnormal operation	Part of the control and protection panel. Multiple digital signal processing modules are integrated as converter and pole control module. Redundancy is provided to improve performance and enhance reliability.
Communication switch	Connects different systems within the HVDC station using high speed fiber optic based Ethernet interface	Part of the control and protection panel. Multiple communication switches with redundancy are used.
Analog input/output (I/O) module	Use to measure the electrical parameters on the HVDC line, converter transformer, reactors, breakers, capacitor banks and filters for protection and monitoring	Connected along the HVDC station near to the equipment to be monitored and the numbers depends upon the power rating

5 TI Solutions for HVDC Transmission Station Control and Protection

TI provides analog, power, interface, isolation, processor, MCU and DSP solutions that can be leveraged by customers during the design of HVDC boards or modules. Some of the focus solutions for different HVDC modules are shown in Figure 7.

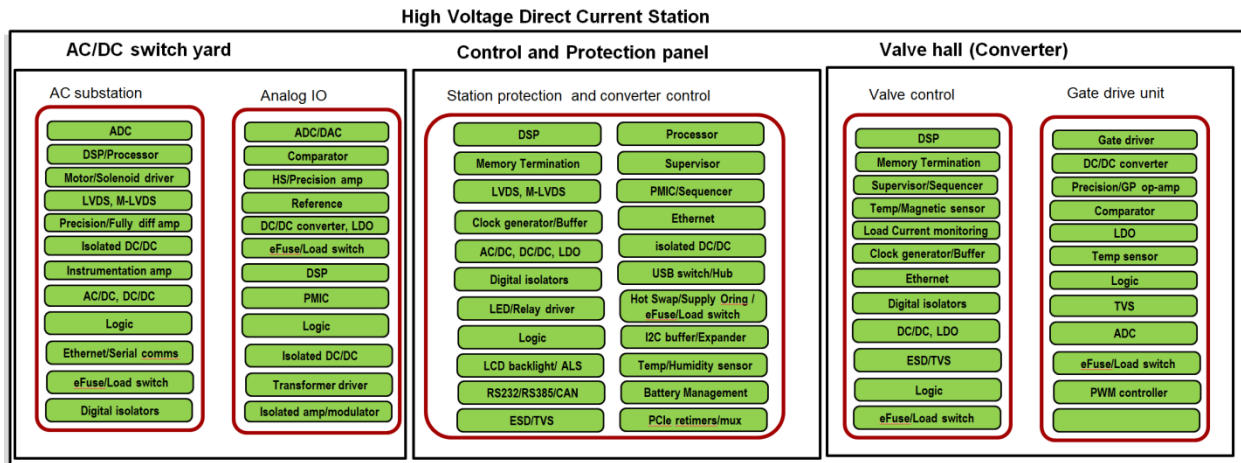

Figure 7. HVDC Transmission Control and Protection – TI Solutions

5.1 TI Products

For details on TI products, see the links in the following sections.

5.1.1 Analog

TI provides a range of analog solutions including precision or high speed ADC, Precision or high speed Amplifiers, high speed comparators and sensors for environment monitoring. The following links provides information on the products.

- <http://www.ti.com/data-converters/adc-circuit/precision-adcs/overview.html>
- <http://www.ti.com/amplifier-circuit/op-amps/precision/overview.html>
- <http://www.ti.com/amplifier-circuit/special-function/fully-differential/overview.html>
- <http://www.ti.com/amplifier-circuit/current-sense/overview.html>
- <http://www.ti.com/amplifier-circuit/comparators/overview.html>
- <http://www.ti.com/sensors/overview.html>

ADS8588H

The ADS8588H device is an 8-channel, integrated data acquisition (DAQ) system based on a 16-bit successive approximation (SAR) analog-to-digital converter (ADC). All input channels are simultaneously sampled to achieve a maximum throughput of 500 kSPS per channel.

5.1.2 Embedded Processing

TI provides a range of embedded processor solution including DSP for control/protection algorithms processing and ARM based processor for implementing standard communication protocols and user interface. The following links provides information on the products.

- <http://www.ti.com/microcontrollers/c2000-real-time-control-mcus/overview.html#portfolio>
- <http://www.ti.com/processors/digital-signal-processors/c6000-floating-point-dsp/overview.html>
- <http://www.ti.com/processors/sitara-arm/overview.html>

66AK2HXX

The 66AK2Hxx platform combines the quad ARM Cortex-A15 processor with up to eight TMS320C66x high-performance DSPs using the KeyStone II architecture. The 66AK2H14/12/06 device provides up to 5.6 GHz of ARM and 9.6 GHz of DSP processing coupled with security, packet processing, and Ethernet switching at lower power than multichip solutions.

5.1.3 Power Supply and Gate Drivers

TI provides a range of power solutions including AC/DC, DC/DC, gate drivers, isolated power modules and LDOs. The following links provides information on the products.

- <http://www.ti.com/power-management/power-switches/overview.html>
- <http://www.ti.com/power-management/gate-drivers/overview.html>
- <http://www.ti.com/power-management/gate-drivers/isolated-gate-drivers/products.html>
- <http://www.ti.com/power-management/offline-isolated-dcdc-controllers-converters/isolated-power-converters/products.html>
- <http://www.ti.com/power-management/offline-isolated-dcdc-controllers-converters/pwm-resonant-controllers/products.html>
- <http://www.ti.com/power-management/non-isolated-dc-dc-switching-regulators/step-down-buck/buck-modules-integrated-inductor/power-modules-portfolio.html>

LMZ30604

The LMZ30604 power module is an easy-to-use integrated power solution that combines a 4-A DC/DC converter with power MOSFETs, a shielded inductor, and passives into a low profile, QFN package. This total power solution requires as few as three external components and eliminates the loop compensation and magnetics part selection process.

5.1.4 High-Speed On-Board Interface and External Communication

TI provides a range of interface solutions for on-board and external interface for both low speed and high speed communication. The following links provides information on the products.

- <http://www.ti.com/interface/ethernet/overview.html>
- <http://www.ti.com/interface/usb/overview.html>
- <http://www.ti.com/interface/lvds-m-lvds-pecl/overview.html>
- <http://www.ti.com/interface/overview.html>
- <http://www.ti.com/wireless-connectivity/simplelink-solutions/sub-1-ghz/products.html#p1694=Smart%20RF%20Transceiver;UHF%20Transceiver>

SN65LVDS047 and SN65LVDS048A

The SN65LVDS047 is a quad differential line driver that implements the electrical characteristics of low-voltage differential signaling (LVDS). The SN65LVDS048A is a quad differential line receiver that implements the electrical characteristics of low-voltage differential signaling (LVDS).

DP83869

The DP83869HM device is a robust, fully-featured Gigabit Physical Layer (PHY) transceiver with integrated PMD sublayers that supports 10BASE-Te, 100BASE-TX and 1000BASE-T Ethernet protocols. The DP83869 also supports 1000BASE-X and 100BASE-FX Fiber protocols.

5.1.5 Board Level Isolation and Protection

TI provides a range of isolation solutions analog or digital with basic or reinforced isolation. The following links provide information on the products.

- <http://www.ti.com/power-management/offline-isolated-dcdc-controllers-converters/isolated-power-converters/products.html>
- <http://www.ti.com/isolation/digital-isolators/overview.html>
- <http://www.ti.com/isolation/isolated-interfaces/rs-485-transceivers/overview.html>
- <http://www.ti.com/isolation/isolated-interfaces/can-transceivers/overview.html>
- <http://www.ti.com/isolation/transformer-drivers/products.html>
- <http://www.ti.com/isolation/isolated-amplifiers/overview.html>
- <http://www.ti.com/interface/circuit-protection/esd-by-interface.html>
- <http://www.ti.com/interface/circuit-protection/overview.html>

ISO224

The ISO224 is a precision isolated amplifier with an output separated from the input circuitry by an isolation barrier of up to 5 kVRMS with an exceptionally long lifetime and low power dissipation. The input of the ISO224 is optimized for accurate sensing of ± 10 -V signals that are widely used in industrial applications. The device operates of a single supply on the high-side. This unique feature simplifies the design of the isolated power supply and reduces the system cost. The integrated high-side supply voltage detection feature simplifies system level diagnostics.

UCC12050

UCC12050 is a DC/DC converter with 5-kVRMS reinforced isolation rating designed to provide efficient, isolated power to isolated circuits that require a bias supply with a well-regulated output voltages. The device integrates a transformer and DC/DC controller with a proprietary architecture to provide 500 mW (typical) of isolated power with high efficiency and low EMI. The device also has an enable pin, synchronization capability, and regulated 5-V or 3.3-V output options with headroom. The UCC12050 is a low-profile, miniaturized solution offered in a wide-body SOIC package with 2.65-mm height (typical).

AMC3301

The AMC3301 is a precision, isolated amplifier with a fully integrated, isolated DC/DC converter that allows single-supply operation from the low-side of the device. The input of the AMC3301 is optimized for direct connection to shunt resistors or low voltage-level signals. The integrated isolated DC/DC converter makes the device a unique solution for space-constrained applications.

ISO774x

The ISO774x devices are high-performance, quad-channel digital isolators with 5000 V_{RMS} (DW package) and 3000 V_{RMS} (DBQ package) isolation ratings per UL 1577. The ISO774x devices provide high electromagnetic immunity and low emissions at low power consumption, while isolating CMOS or LVCMOS digital I/Os. Each isolation channel has a logic input and output buffer separated by a double capacitive silicon dioxide (SiO₂) insulation barrier. If the input power or signal is lost, default output is *high* for devices without suffix F and low for devices with suffix F.

6 Summary

HVDC offers advantages of reduced losses and increased transmission distance. Transmission companies are transitioning from HVAC to HVDC in bulk power, long distance transmission. TI provides analog, digital, interface and protection products and reference design solution for end equipments used in HVDC transmission system. Along with HVDC station control and protection equipments, other equipments for environment monitoring, valve cooling, de-icing, smoke detection and security are integrated in a HVDC station.

7 TI Reference Designs

- [High-Efficiency, Low-Emissions, Isolated DC/DC Converter Based Analog Input Module Reference Design](#)

This reference design is a simplified architecture for generating an isolated power supply for isolated amplifiers for measuring isolated voltages and currents. A fully integrated DC/DC converter with reinforced isolation operating from a 5-V input with configurable 5-V or 5.4-V output (headroom for low dropout regulator (LDO)) generates the isolated power. Shunts that are interfaced to ± 50 -mV input range isolation amplifiers configured as channel isolated inputs measure the current. Potential divider output interfaced to ± 250 -mV or ± 12 -V input range isolation amplifiers configured as group isolated inputs measure the voltage. The outputs of the isolation amplifiers interface directly to 24-bit delta sigma analog-to-digital converter (ADC) or are scaled to ± 10 V using gain amplifiers and interfaced to 16-bit SAR ADC for performance evaluation. On-board digital diagnostics improves reliability and enhances system performance.

- [Non-isolated Power Architecture With Diagnostics Reference Design for Protection Relay Modules](#)
- [High Efficiency Power Supply Architecture Reference Design for Protection Relay Processor Module](#)

This reference design is a simplified architecture for generating an isolated power supply for isolated amplifiers for measuring isolated voltages and currents. A fully integrated DC/DC converter with reinforced isolation operating from a 5-V input with configurable 5-V or 5.4-V output (headroom for low dropout regulator (LDO)) generates the isolated power. Shunts that are interfaced to ± 50 -mV input range isolation amplifiers configured as channel isolated inputs measure the current. Potential divider output interfaced to ± 250 -mV or ± 12 -V input range isolation amplifiers configured as group isolated inputs measure the voltage. The outputs of the isolation amplifiers interface directly to 24-bit delta sigma analog-to-digital converter (ADC) or are scaled to ± 10 V using gain amplifiers and interfaced to 16-bit SAR ADC for performance evaluation. On-board digital diagnostics improves reliability and enhances system performance.

- [Flat-Clamp TVS Based Reference Design for Protection Against Transients for Grid Applications](#)
- [EMI/EMC Compliant 10/100 Mbps Ethernet Brick with Fiber or Twisted Pair Interface Reference Design](#)
- [Copper-to-Fiber 100BASE-FX or 1000BASE-X Media Converter Reference Design for Grid Applications](#)

This reference design details a methodology to use the DP83849 evaluation board to implement a 10/100BASE-TX to 10/100BASE-FX media converter, which enables copper based legacy equipment to be easily connected to a fiber network. Copper based Ethernet (10/100BASE-TX) has been widely used in grid local area networks, but with limited communication distance. Fiber optic networking has been well established and has continuous cost reductions. It is feasible and cost efficient for utility to use fiber optic networks to manage wide area equipment, which brings higher speed, longer coverage distance, and more reliable communication.

- [Three-Level, Three-Phase SiC AC-to-DC Converter Reference Design](#)
- [IGBT Gate Driver Reference Design for Parallel IGBTs With Short-Circuit Protection and External BJT Buffer](#)
- [Reinforced, Isolated, Phase-Current Sense Reference Design With Small Delta-Sigma Modulators](#)
- [Reference Design for Reinforced Isolation Three-Phase Inverter With Current, Voltage, and Design Guide](#)

8 Additional References

- <http://www.ti.com/applications/industrial/grid-infrastructure/overview.html>
- Texas Instruments: [System-Level ESD Protection Guide](#)
- https://e2e.ti.com/blogs_/b/industrial_strength/archive/2017/03/07/exploring-high-voltage-transmission-part-1-line-commutated-converters
- https://e2e.ti.com/blogs_/b/industrial_strength/archive/2017/03/14/exploring-high-voltage-transmission-part-2-voltage-source-converters
- Texas Instruments: [Comparative Analysis of Two Different Methods for Gate-Drive Current Boosting](#)

Revision History

NOTE: Page numbers for previous revisions may differ from page numbers in the current version.

Changes from Original (May 2020) to A Revision	Page
• Updates were made in Section 1.1	2
• Update was made in Section 1.2.1	2
• Updates were made in Section 2.2.2.1	6
• Update was made in Section 6	15

IMPORTANT NOTICE AND DISCLAIMER

TI PROVIDES TECHNICAL AND RELIABILITY DATA (INCLUDING DATASHEETS), DESIGN RESOURCES (INCLUDING REFERENCE DESIGNS), APPLICATION OR OTHER DESIGN ADVICE, WEB TOOLS, SAFETY INFORMATION, AND OTHER RESOURCES "AS IS" AND WITH ALL FAULTS, AND DISCLAIMS ALL WARRANTIES, EXPRESS AND IMPLIED, INCLUDING WITHOUT LIMITATION ANY IMPLIED WARRANTIES OF MERCHANTABILITY, FITNESS FOR A PARTICULAR PURPOSE OR NON-INFRINGEMENT OF THIRD PARTY INTELLECTUAL PROPERTY RIGHTS.

These resources are intended for skilled developers designing with TI products. You are solely responsible for (1) selecting the appropriate TI products for your application, (2) designing, validating and testing your application, and (3) ensuring your application meets applicable standards, and any other safety, security, or other requirements. These resources are subject to change without notice. TI grants you permission to use these resources only for development of an application that uses the TI products described in the resource. Other reproduction and display of these resources is prohibited. No license is granted to any other TI intellectual property right or to any third party intellectual property right. TI disclaims responsibility for, and you will fully indemnify TI and its representatives against, any claims, damages, costs, losses, and liabilities arising out of your use of these resources.

TI's products are provided subject to TI's Terms of Sale (www.ti.com/legal/termsofsale.html) or other applicable terms available either on ti.com or provided in conjunction with such TI products. TI's provision of these resources does not expand or otherwise alter TI's applicable warranties or warranty disclaimers for TI products.

Mailing Address: Texas Instruments, Post Office Box 655303, Dallas, Texas 75265
Copyright © 2020, Texas Instruments Incorporated