



2020

TAHOE PPV 2WD



Shown with equipment from independent suppliers not covered by the GM New Vehicle Limited Warranty. GM is not responsible for the safety or quality of independent supplier alterations.

GENERAL MOTORS FLEET





About This Publication

This catalog is not updated during the model year and should not be used for ordering purposes. It is intended as a source of basic information. All illustrations and specifications in this literature are based on the latest product information available at the time of publication. General Motors reserves the right to make changes at any time without notice. For further details, consult your local dealer.

Care must be taken during customer installation of equipment and wiring to ensure that all holes drilled in the body are corrosion protected, properly sealed and that vehicle wiring harnesses, piping or other components have not been displaced or damaged. Wiring connection or splice changes are to be removed before the vehicle is returned to civilian use. Aftermarket equipment installers must be mindful of applicable Federal Motor Vehicle Safety Standards. This information can be obtained directly from the National Highway Traffic Safety Administration.

Adding non-dealer accessories or making modifications to the vehicle can affect vehicle performance, aerodynamics, and overall top speed.

These vehicles are equipped with an airbag system. The airbag system in your police vehicle includes frontal driver and front outboard passenger airbags, front seat back side impact airbags, roof rail mounted head-curtain airbags. Customer installed equipment such as security barriers behind the front seats should not be mounted so that the barrier ends are within the side airbag deployment zones. The sensors and other components for the airbag system must not be relocated to accommodate the installation of customer furnished equipment; please refer to the service manual for sensor and other component locations. For information concerning instrument panel top pad mounted equipment and airbag system deployment zones, see the airbag information section in this catalog and the vehicle owners manual.

A note about vehicle alterations by independent suppliers: This catalog shows pictures of vehicles that have been altered or upfitted with equipment or components supplied to Chevrolet or its dealers by independent suppliers. Chevrolet is not responsible for the safety or quality of design features, materials or workmanship of any alterations by a supplier.

INDEX

- **UPDATES FOR 2020 TAHOE
2WD POLICE PACKAGE**
- **STANDARD FEATURES**
- **POWERTRAIN & EMISSIONS**
- **COLORS & INTERIOR TRIM**
- **SPEEDOMETER/CLUSTER DISPLAY**
- **RADIO SCREEN DISPLAY**
- **OPTIONAL EQUIPMENT**
- **GENERAL MOTORS FLEET OnStar®
PLANS AND GM COMMERCIAL
LINK PLANS**
- **SPECIFICATIONS**
- **ILLUSTRATION HIGHLIGHTS**
- **LOADING ZONES**
- **WIRING DIAGRAMS**
- **AIRBAG DIMENSIONS**
- **AIRBAGS FAQ**
- **STABILITRAK**
- **MAINTENANCE AND WARRANTY**



Shown with aftermarket equipment



Fully accessible underbody spare tire standard



Shown with after-market equipment and optional aluminum wheels

UPDATES FOR 2020

NEW FEATURES

- Cosmetic Grille Enhancement
- (GLR) Black Cherry Metallic exterior paint color

DISCONTINUED

- (GMU) Pepperdust Metallic exterior paint color

2020 TAHOE 2WD POLICE PACKAGE 9C1

The two-wheel drive Tahoe Police Package (9C1) has been designed for police work up to, and including, high-speed emergency vehicle operations. GM restricts the sale of police vehicles and they are not to be sold to retail customers. Model CC15706 (two-wheel drive) with equipment group 1FL is required when ordering 9C1 Police Package. Content, Options and Specifications shown are for Police and Special Service Vehicles only which differ from retail civilian model.

9C1 PPV Package includes: Heavy-duty police-rated suspension with unique StabiliTrak performance calibration, front independent torsion bar, stabilizer bar and rear multi-link with coil springs. Police brakes, black steel wheels with bolt-on center caps, P265/60R17 all-season v-rated tires with matching full-size spare and underbody shields. Front bumper cover with unique brake cooling knock-outs and modified lower air dam. High-capacity air cleaner, dual battery isolator with 730 cold-cranking amp auxiliary battery, 170 amp high output alternator, auxiliary battery circuit for customer connection located in rear cargo area, electrical power & vehicle signals for customer located on center front floor and under dash surveillance mode circuit. Certified speedometer, work truck steering wheel, third row seat delete, unique tailgate struts and roof rail mounted head-curtain delete.

STANDARD 9C1 INTERIOR FEATURES

AIR CONDITIONING	Tri-zone, Automatic with digital display. Includes Driver, Front Passenger and Rear Passenger zones (controlled by driver)
ASSIST HANDLES	Front passenger and second row outboard; front passenger assist handle is deleted when passenger side spotlight is ordered
AUDIO SYSTEM FEATURES¹	Chevrolet Infotainment System with 8" diagonal color touch-screen, AM/FM stereo with seek-and-scan and digital clock, includes Bluetooth® streaming audio for music and select phones; voice-activated technology for radio and phone; and Shop with the ability to browse, select and install apps to your vehicle. Includes 4 USB ports and 1 auxiliary jack. The 8-inch diagonal color touch-screen slides up to reveal a password-protected area behind the display with space for cell phones, wallets or other valuables. Additionally, a USB port gives you one more place to charge your devices. Includes 6 Speakers and Single-slot CD/MP3 player
BLUETOOTH® FOR PHONE²	Bluetooth® cell phone connectivity Displayed on radio screen (see standard equipment illustrations section) Bluetooth® microphone is same location as OnStar®. It is located on the headliner in front of driver's sun visor. Bluetooth® phone conversations are broadcast over the 4 front speakers. The speakers are located in the left front door/right front door/left side of dash/right side of dash
4G LTE WI-FI HOTSPOT³	Available 4G LTE Wi-Fi® hotspot can connect up to 7 devices; includes 4G LTE data trial for 1 month or 3GB (whichever comes first). Available Wi-Fi requires compatible mobile device, active OnStar service and data plan. Data plans provided by AT&T. Visit www.gmfleet.com/technology/connected-vehicle.html for details and system limitations
FLEET CONNECTED ACCESS	Chevrolet Connected Access with 10 years of standard connectivity which enables services such as, Vehicle Diagnostics, Dealer Maintenance Notification, Chevrolet Smart Driver, Marketplace and more. Limitations apply. Not transferable. Standard connectivity available to original purchaser for ten years from the date of initial vehicle purchase for model year 2018 or newer Chevrolet vehicles. See www.gmfleet.com/technology/connected-vehicle.html for details and further plan limitations. Connected Access does not include emergency or security services. Availability and additional services enabled by Connected Access are subject to change
COMPASS	Displayed on Speedometer Cluster (see Picture on Speedometer/Cluster page)
CONSOLE, OVERHEAD	Includes Rear Seat Panoramic Mirror, Map lights, Passenger airbag indicator and Sunglasses holder
CRUISE CONTROL	Electronic with set and resume speed
DRIVER INFORMATION CENTER	4.2" diagonal multi-color
FLOOR COVERING	Black rubberized vinyl floor and load floor behind second row seats, see illustration section for description (carpeting and carpeted floor mats are available, see option B30 and B58 see available options page)
GLASS	Deep-tinted, all windows (except for windshield, and driver/front-passenger side glass which are light-tinted). Front doors have a 24.6% UV transmission Rear door and cargo glass is 12% +/- 3% transparency and front glass has 70% minimum. Non-tinted, solar absorbing glass available (see option AKP see available options page)
GLOVE BOX	Locking door without courtesy light (uses ignition key)
INSTRUMENTATION	Digital Speedometer and 150 mph certified analog speedometer, 1 mph increments and digital trip odometer with gauges for engine oil pressure, fuel, battery volts, coolant temperature and tachometer. Driver Information Center displays engine hours, warnings, and backup sensor proximity status while in reverse. (see message listing for additional features)
LIGHTING	Interior with dome light, cargo lights, door handle or Remote Keyless Entry-activated illuminated entry and map lights in front and second seat positions with control switch in the roof console
MIRROR, INSIDE	Rearview, manual day/night
NAVIGATION	Available only with active OnStar® ¹ account that includes Turn-by-Turn directions plan; directions are displayed as text on radio. Does not include map view navigation screen
OCCUPANT SENSING SYSTEM	Automatic Occupant Sensing System, sensor indicator inflatable restraint, front passenger
OnStar®⁴	Fleet orders receive a 3-month trial of Fleet connected services and 3 months of Fleet Safety & Security plan coverage. Connected services include navigation services, Remote Access Plan and 1 month or 3GB of 4G LTE data (whichever comes first) from vehicle delivery date. Data plans offered by AT&T. Certain services require working electrical system, cell service and GPS signal. OnStar links to emergency services. See www.gmfleet.com/technology/connected-vehicle.html for details and limitations
REAR VISION CAMERA⁵	While in Reverse, allows driver to view objects directly behind the vehicle via the screen in the center stack, includes dynamic guidelines (see illustration section for description)
REAR PARK ASSIST⁵	Sensors for audible warning on rear bumper to assist with parking and avoiding objects while in reverse. (see illustration section for description)

1. Functionality varies by model. Full functionality requires compatible Bluetooth and smartphone. Some devices require USB connectivity.

2. Go to my.chevrolet.com/learn to find out which Bluetooth phones are compatible with the vehicle

3. Service varies with conditions and location. Requires active service plan and paid AT&T data plan. See onstar.com for details and limitations

4. Services subject to user terms and limitations. Certain services require working electrical system, cell reception and GPS signal. OnStar links to emergency services. Data plans offered by AT&T. See gmfleet.com/connected services for details. Availability subject to change

5. Read the vehicle Owner's Manual for more important feature limitations and information.

2020 TAHOE 2WD POLICE PACKAGE 9C1

RESTRAINT SYSTEM	Seat belts at all designated seating positions with driver and front outboard passenger pretensioners. Airbags ⁶ : Dual-stage frontal airbags for driver and front outboard passenger; includes front outboard Passenger Sensing System. Seat-mounted side-impact airbags for driver and front outboard passenger; driver seat-mounted inboard side-impact airbag (requires bucket seats); Head Curtain airbags for all rows at outboard seating positions. Note: Nine inch seatbelt extenders are available (part number 19259268) through our dealers at no charge
SEATS, FRONT	CLOTH 40/20/40 individual seats, 3 passengers with 10-way power driver seat adjuster (fore/aft, up/down, tilt, recline, and lumbar), and 6-way power passenger seat adjuster. Adjustable outboard head restraints and storage pockets. Center seat section can be deleted (9U3) for 15" of open floor space (see front seats and interior trim illustration page for description)
SEAT, REAR	CLOTH split-folding 60/40 bench seats includes folding center armrest with cup holders, outboard seating position headrests and reclining rear seat back. (Vinyl 2nd row seat option 5T5) 3rd row seats not available (see front seats and interior trim illustration page for description)
STEERING WHEEL	Tilt-wheel with cruise control and column mounted gear shift lever
STEERING WHEEL CONTROLS	Mounted audio and cruise controls, includes Driver Information Center controls
SURVEILLANCE FEATURE	Body Control Module calibration is available to disable all automatic interior and exterior lighting. Feature requires connection to BCM by customer. Feature operates with or without SEO 9G8, delete Daytime Running Lamps and Automatic Headlamps. (see Interior/Exterior Lamps Control, see illustration section for description)
TEEN DRIVER MODE	A configurable feature that can be programmed through your radio that lets you activate customizable vehicle settings associated with a key fob, to encourage safe driving behavior. It can limit certain vehicle features, and it prevents certain safety systems from being turned off. An in-vehicle report gives you information on your driving habits
THEFT DETERRENT SYSTEM	Vehicle Immobilizer (prevents vehicle start without correct key or remote) and Content Theft System (unauthorized entry, or entry without use of remote fob, sounds horn and lamps flash). Content Theft Alarm Disable, Option UTQ, must be ordered to disable alarm. (See your Owner's Manual for System operation information)
VISORS	Padded with cloth trim, extends on rod; driver and front passenger illuminated vanity mirrors
WARNING TONES	Headlamp on, key-in-ignition, driver and right-front passenger seat belt unfasten, backup sensor with warning tone and turn signal on
WINDOW OPERATION	Power with driver express up/down and lockout features
STANDARD 9C1 EXTERIOR FEATURES	
ASSIST STEPS	Black, mounted between front and rear wheels
BODY SIDE MOLDINGS	Optional (see available options page)
CAPLESS FUEL FILL	The vehicle has a capless refueling system and does not have a fuel cap. The filling nozzle must be fully inserted and latched prior to starting fuel flow. NOTE: Overfilling the fuel tank by more than three clicks of a standard fill nozzle may cause vehicle performance issues, including engine stalling and damage to the fuel system, fuel spills, potential fuel fires
DEFOGGER	Electric, rear window
DOOR HANDLES	Body color
DOOR LOCKS	Power programmable; Lockout is disabled; see LOCK-OUT PROTECTION description shown under STANDARD 9C1 ELECTRICAL FEATURES below. Door locks can be programmed via radio settings menu (see standard equipment illustrations section). Lock cylinder not available on passenger front door or rear liftgate. Child safety door and window locks individually controlled electronically by driver door mounted switches. Includes 2 remote transmitters
FASCIA, FRONT	Body color with police specific extension for increased brake cooling and ground clearance. Fascia comes with tow hook openings but does not include tow hooks. For tow hooks see Option V76 Recovery Hooks on exterior options page
FASCIA, REAR	Body color with step pad
FOG LAMPS	Not available
HEADLAMPS	Dual halogen with flash-to-pass feature, automatic exterior lamp control and daytime running lamps. Daytime running lamps are LED. To disable daytime running lamps and automatic lamps control, see option 9G8 on the available options page. Altering headlamp assembly is not recommended, General Motors is not responsible for the effects of any modifications
HORNS	Dual note
KEYS	Two-sided, random code, for ignition, driver door and glove box. Six additional keys are available (maximum 8 keys can be programmed per vehicle). See available options page. Fleet keyed-alike is available. See available options page
KEYLESS ENTRY REMOTES	Includes two extended-range transmitters with non-functional panic button; stealth mode feature includes exterior lamps and horn disable as default setting. Remote feedback is programmable via radio settings if light and or horn lock/unlock notification is desired. Daytime running lamps will remain illuminated when optional (BTV) remote start is activated. Additional transmitters are available; see available options page
LUGGAGE RACK	Not available
MIRRORS, OUTSIDE	Heated power-adjustable, manual-folding, color keyed, driver-side includes spotter mirror
RADIO ANTENNA	Located in rear quarter glass
REAR LIFTGATE	Manual with exterior liftgate and glass hatch release buttons. Includes remote fob with unlock buttons

⁶ Always use seat belts and child restraints. Children are safer when properly secured in a rear seat in the appropriate child restraint. See the Owner's Manual for more information.





2020 TAHOE 2WD POLICE PACKAGE 9C1

TIRES	Goodyear P265/60R17 all-season, V-rated, blackwall, (see standard equipment illustrations section) includes matching spare tire
TIRE PRESSURE MONITOR WITH TIRE FILL ALERT	Tire Pressure Monitoring System. Standard spare wheel not equipped with TPM sensor. Includes Tire Fill Alert in addition to the DIC warning when a tire has low pressure, this feature provides audible and visual indication when air is being added to the low tire to aid in achieving optimal tire pressure sensor; must be programmed when mounted (see standard equipment illustrations section)
TIRE, SPARE	Full-size spare, lockable with outside winch-type carrier mounted under frame at rear. (includes TPM sensor - not programmed)
UNDER HOOD LAMP	Not available
WHEELS	17" x 8" black steel (includes matching full-size spare)
WHEEL CENTER CAP	Bolt-on metal, black finish
WINDSHIELD	Solar absorbing shaded upper with acoustic laminated glass
WINDSHIELD WIPERS	Intermittent, with rain sensing
STANDARD 9C1 ELECTRICAL FEATURES	
AUXILIARY POWER, FRONT	170-Amp ignition and main power supply wiring at lower center of instrument panel: 120- amp primary battery ignition controlled relay power and 50-amp auxiliary battery power (see specifications page for description)
AUXILIARY POWER, REAR	100-amp cargo area (auxiliary battery powered) (see illustration section for description)
LOCK-OUT PROTECTION	Lockout Protection is not available with the Tahoe Police and Special Service Vehicle. When locking is requested with the driver door open and the key in the ignition, all doors will lock and remain locked. The key-in-ignition audible warning will sound while the driver door is open. The locked driver door can be closed with the key in the ignition. If running, the engine will remain running
POWER OUTLETS	110-volt (3 prong outlet) located in the lower center stack. 110 volt, 60 Hertz power outlet is rated 150 watts (1.36 amps at 110v). Overload power before automatic shut off is 275 watts for 10 seconds or 418 watts for 1 second. Also includes four auxiliary 12-volt outlets including one on the instrument panel, one in the center fold-down seat storage, and two in the cargo area. Outlet power is configurable to be Battery Powered at all times or Ignition Controlled Power. See the Standard Equipment Section for description of selecting Outlet power configuration
WIRING DIAGRAMS	See Wiring Section for description; also see Tahoe Police Package owner's manual supplement (located in glove box folder with standard owner's manual)
STANDARD 9C1 MECHANICAL FEATURES	
AIR CLEANER	High-capacity
ALTERNATOR	170-amp high output with idle boost based on battery energy level (see specifications page for description)
AXLE	3.08 Ratio with heavy-duty locking differential
BATTERIES	Primary 720 CCA, 80 amp-hour rating with battery rundown protection (may be configured to protect customer installed equipment). Isolated, Auxiliary 730 CCA, 70 amp-hour battery without battery run-down protection for customer installed equipment. (see specifications page)
BATTERY RELAY	Auxiliary Battery Relay
BRAKES	Heavy-duty 4-wheel anti-lock front and rear disc with vacuum boost power assist
COOLING	Heavy-duty high-capacity radiator, electric fans and extended life coolant; coolant hoses are EPDM (ethylene-propylene-diene monomer) rubber; silicone hoses are not required (coolant is DEX-COOL good for 5 years/150,000 miles, protects from -34° F to +265° F and against rust and corrosion)
ENGINE	5.3L EcoTec3 V8 with direct injection, variable valve timing (VVT), Active Fuel Management (AFM), aluminum block, Flex Fuel includes air conditioning wide open throttle cut off (see powertrain page for description and emissions, see also specifications page)
EXHAUST	Aluminized stainless-steel muffler and tailpipe
FRAME	Full perimeter, modular with hydroformed rails (includes ground straps. See Radio Suppression below)
FUEL TANK CAPACITY	26 gallon (98 liters)
HILL START ASSIST	This feature is designed to prevent the vehicle from rolling, either forward or rearward, during vehicle drive off
OIL COOLERS	Engine oil, oil-to-coolant heat exchanger in passenger side of coolant radiator. Transmission oil, oil-to-coolant heat exchanger in upper portion of the AC condenser (see illustration section for description)
PROP SHAFT	4 inch diameter aluminum
RADIO SUPPRESSION	The Tahoe vehicle systems are designed to prevent unwanted emissions and to minimize susceptibility and maximize immunity to external emissions (Electromagnetic (EMI) or Radio Frequency (RFI) Interference). Most emergency vehicle communications equipment operating at frequencies in the VHF Band (30-300 MHz) and up to frequencies in the UHF Band (300 MHz-3GHz) will function as intended without enhanced noise suppression. If additional noise suppression grounding is desired, see the Optional Equipment listing for UN9, Radio Suppression Ground Straps
REAR DIFFERENTIAL	Heavy-duty locking
	1. E85 is 85% ethanol and 15% gasoline.

2020 TAHOE 2WD POLICE PACKAGE 9C1

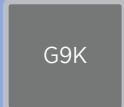
SPARK PLUGS	Extended life - iridium tip
STABILITRAK	The stability system is capable of recognizing high performance driving with a Track Detect Mode. When continuous high performance driving occurs in 2WD, the stability system will automatically enter Competition Mode. When engaged, the message "Competition Mode" will appear in the DIC and the Traction Control OFF and StabiliTrak OFF lights will illuminate. (see Standard Equipment Illustration section for StabiliTrak button location) Competition mode can be disengaged by any of these four methods: <ul style="list-style-type: none"> -Discontinue high performance driving for approximately 2 minutes -Place transmission shift lever into Park for a brief period of time -Press and hold button to completely disable Traction Control and press again to re-enable all stability systems -Turn engine off
STEERING	Electric power-assisted rack and pinion (see illustration section for description)
SUSPENSION, FRONT	Heavy-duty, police-rated. Includes specific spring rates, ride height, shock tuning and stabilizer bar
SUSPENSION, REAR	Multi-link, coil springs and stabilizer bar
TRAILERING EQUIPMENT	SAE Class II hitch with 2 inch (51 mm) square receiver. Trailer may weigh up to 4,000 pounds (1,844 kg) with proper hitch selection. See the Owners Manual for additional information
TRANSMISSION	Enhanced calibration 6-speed automatic with overdrive and tow/haul mode. Electronically-controlled transmission provides protection against over-revving the engine in low gear and a mechanical low gear blockout is not required; if a driver manually selects low gear and fails to manually upshift to high gear, the powertrain control module automatically protects the drivetrain. The transmission is calibrated to maintain lower gears when driving aggressively. This enhances vehicle control while driving through corners and when throttling up to exit a corner, keeping the transmission in one gear instead of upshifting and downshifting avoids "hunting" for a gear state
UNDER BODY SHIELD, FRONT	Two-piece heavy-duty aluminum front underbody shield starting behind front bumper and running to 2nd cross-member protecting front underbody and oil pan (see illustration section for description)
WARRANTY	Maintenance and Warranty information (see Maintenance and Warranty section for description)

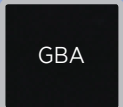
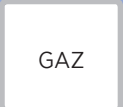
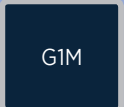
AVAILABLE EXTERIOR COLORS Actual colors may vary

 GAN	 G9K	 GJI	 GBA	 GAZ	 G1M	 GLR	 G1E
Silver Ice Metallic	Satin Steel Metallic	Shadow Gray Metallic	Black	Summit White	Blue Velvet Metallic	*Black Cherry Metallic	*Siren Red Tintcoat

* Additional Charge.

SEO PAINT AVAILABLE

COLOR DESCRIPTION	SEO CODE	WA#
MSP Blue	9V2	WA-5665
Woodland Green	9V5	WA-9015
Victory Red ¹	5T4	WA-9260
Wheatland Yellow (86U)	9W3	WA-253A
Dark Toreador Red	—	WA-334D

Note: Will require 5 orders before sending to plant
1 - Requires SEO (5T4) Exterior body colored parts

AVAILABLE INTERIOR COLOR Actual colors may vary

 HOU	 5T5
Black Cloth	Black Vinyl

FRONT SEATS AND INTERIOR TRIM

STANDARD Cloth front 40/20/40 Individual Seats (AZ3) 3-Occupant, Center seat can be unbolted for removal. Center fold-down armrest with USB, Auxiliary Jack and Auxiliary Power connection and lockable seat cushion storage. STANDARD 10-way power driver seat, includes power lumbar and power recline. STANDARD 6-way power front passenger seat. Outboard seat back thoracic-pelvic airbags.

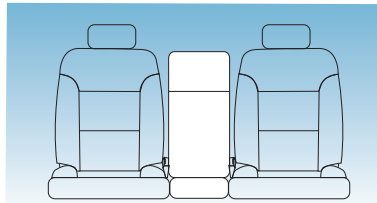
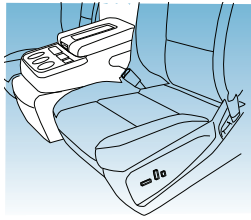
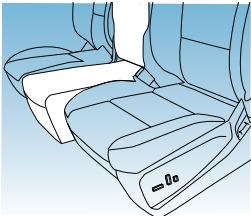

Seat Code	Seat Trim	Color	Color Code
AZ3	Cloth	Jet Black	HOU

- Front cloth and vinyl rear seat combination is available by ordering option 5T5 and requires Jet Black (HOU)
- Center seat can be unbolted for removal

OPTIONAL - SEO 9U3 20% SEAT DELETE Cloth Front 40/40 Individual Seats (AZ3 & Option 9U3)

Deletes center seat to provide 15" of open space between Driver and Passenger Seat. STANDARD 10-way power driver seat, includes power lumbar and power recline. Outboard seat back thoracic-pelvic airbags. STANDARD 6-way power front passenger seat. A separate cable and connection kit for the USB, Auxiliary Jack and Auxiliary Power is provided in the vehicle when the center seat is deleted.

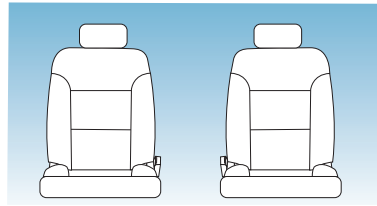
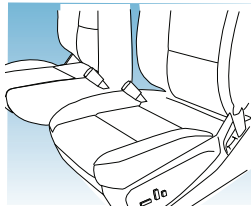

Seat Code	Seat Trim	Color	Color Code
AZ3 & 9U3	Cloth	Jet Black	HOU

- Front cloth and vinyl rear seat combination is available by ordering option 5T5 and requires Jet Black (HOU)

OPTIONAL - A95 BUCKET SEATS Cloth Bucket Seats with Console Driver and Passenger Front Bucket Cloth Seats, with integrated retail console. 10-way Power Driver and Passenger Seats. Includes (AYQ) Airbags¹, Frontal airbags for driver and front outboard passenger; Seat-mounted side-impact airbags for driver and front outboard passenger; Driver inboard seat-mounted side-impact airbag (requires bucket seats); Head-curtain airbags for all rows in outboard seating positions.

Not recommend for vehicles intended to be up-fitted with aftermarket equipment.

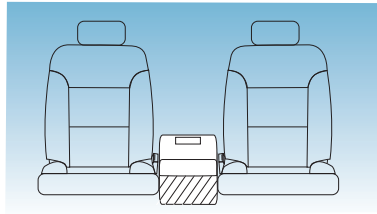
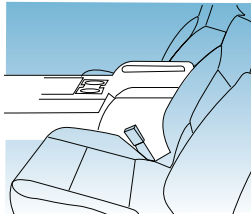

Seat Code	Seat Trim	Color	Color Code
A95	Cloth	Jet Black	HOU

- Front cloth and vinyl rear seat combination is available by ordering option 5T5 and requires Jet Black (HOU)
- Console cannot be deleted
- SD card reader not available

REAR SEATS AND INTERIOR TRIM

STANDARD

Cloth Second Row 60/40 Split-folding Bench Seat (AT6) Includes folding center armrest with cup holder

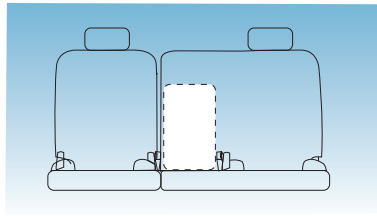
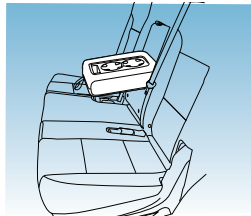
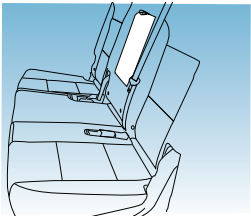

Seat Code	Seat Trim	Color	Color Code
AT6	Cloth	Jet Black	HOU

- Color is based on front seat choice

OPTIONAL - SEO 5T5 VINYL REAR SEAT

Vinyl Second Row 60/40 Split-folding Bench Seat (Option 5T5)

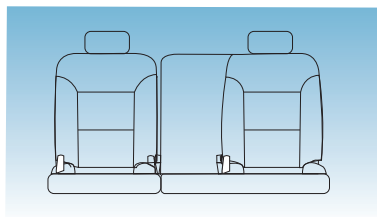
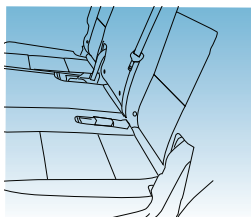

Seat Code	Seat Trim	Color	Color Code
5T5	Vinyl	Jet Black	HOU

- Front cloth and vinyl rear seat combination is available by ordering option 5T5 and requires Jet Black (HOU)

NOTE: Third row seating is not available and head-curtain airbags extend into cargo area.

¹ Always use seat belts and child restraints. Children are safer when properly secured in a rear seat in the appropriate child restraint. See the Owner's Manual for more information.

UNITED STATES CERTIFIED SPEEDOMETER/CLUSTER
(CANADIAN SIMILAR)



DRIVER INFORMATION CENTER

DIC MAIN MENU

- INFO
- AUDIO
- PHONE
- NAVIGATION
- OPTIONS

ACTIVE INFO PAGES as listed in
DIC main menu item **OPTIONS** above

- Speed
- Trip A
- Trip B
- Fuel Range
- Oil Life
- Tire Pressure
- Fuel Economy
- Timer
- Engine Hours
- Transmission Fluid
- Off-Road
- Blank Page



STEERING WHEEL MENU CONTROLS

SPEEDOMETER CERTIFICATION
CALIBRATION

Specifications at ambient temperature of -10 to 120 degrees F (-23 to 49 Celsius). Inaccuracies due to vehicle speed sensing are included.

ACTUAL VEHICLE SPEED	INDICATED SPEED
0 TO 120 MPH	+/- 2 MPH
0 TO 193 KPH	+/- 3 KPH

The speedometer calibration is for the 5.3L engine, automatic transmission with a 3.08 axle and P265/60R17 V-rated tires

RADIO DISPLAY SCREEN AND RADIO CONTROLS



SETTINGS MENU

- Time and Date
- Rear Seat Reminder
- Language
- Valet Mode
- Teen Driver
- Radio
- Vehicle
 - Climate and Air Quality
 - Collision/Detection System
 - Comfort and Convenience
 - Chime Volume
 - Auto Wipe in Reverse Gear
 - Lighting
 - Vehicle Locator Lights
 - Exit Lighting
 - Power Door Locks
 - Auto Door Lock
 - Auto Door Unlock
 - Delayed Door Lock
- Bluetooth®
 - Device Management
 - Ringtones
 - Voice Mail Numbers
 - Text Message Alerts
- Apple Carplay
- Android Auto
- Voice
- Display
 - Calibrate Touchscreen
 - Turn Display Off
- Rear Camera
 - Guidance Lines
 - Rear Park Assist Symbols
- Return to Factory Settings
- Software Information
- WiFi

Remote keyless entry/lock feedback and courtesy lighting are programmable through radio menu. Factory default condition for Remote Keyless Entry feedback and exit lighting is enabled in Surveillance Mode (exterior lamps do not flash, horn does not sound).

OPTIONAL EQUIPMENT & FEATURES

INTERIOR

RWU	CARGO AREA ORGANIZER - Collapsible
B30	CARPET FLOOR COVERING - Includes rear cargo area with front and 2nd row color keyed floor mats
UTQ	CONTENT THEFT ALARM DISABLE - Flashing lamps and horn warning disable (To avoid inadvertent alarm activation this option is recommended for customers that do not intend on using keyless entry remote fobs)
PCW	ENHANCED DRIVER ALERT PACKAGE - Includes (JF4) Power-adjustable pedals, (UEU) Forward Collision Alert, (TQ5) IntelliBeam headlamps, (UHY) Automatic Emergency Braking, (UHX) Lane Keep Assist with Lane Departure Warning and Safety Alert Seat
AAK	FLOOR LINER ALL WEATHER - 1st and 2nd rows, bright finish badge. Requires (B30) color-keyed floor covering. Not available with (VAV) All-weather floor mats
RIB	FLOOR LINER PACKAGE - All-Weather, includes 1st, 2nd and 3rd row coverage. Requires (B30) color-keyed carpeting floor covering. Not available with (AAK) all-weather floor liner, (VAV) all-weather floor mats
VAV	FLOOR MATS - All weather Requires (B30) floor covering
6E2	KEY COMMON - All vehicles in fleet, provides a single key cut with a specific code that is common to the door lock and ignition of all the vehicles in the vehicle fleet; this key code is an alternate to SEO 6E8 key common, complete vehicle fleet; An unlimited number of ignition keys may be programmed to a vehicle. Not compatible with Caprice or Impala. Not compatible with 2014 or older Tahoe
6E8	KEY COMMON - All vehicles in fleet, provides a single key cut with a specific code that is common to the door lock and ignition of all the vehicles in the vehicle fleet; this key code is an alternate to SEO 6E2 key common, complete vehicle fleet; An unlimited number of ignition keys may be programmed to a vehicle. Not compatible with Caprice or Impala. Not compatible with 2014 or older Tahoe
AMF	KEYLESS ENTRY TRANSMITTERS - Fleet Package includes 6 additional transmitters. Transmitters are not programmed. Each transmitter, including the two standard with the vehicle, must be programmed together by the customer or a dealer at customer expense. Transmitter programming is not a warranty item. See programming remote key transmitter instructions. Vehicle specific, common fleet transmitter frequency is not available
5HP	KEYS - 6 additional, keys are not programmed to vehicle. Each key, including the 2 delivered with the vehicle, must be programmed at the same time by the customer or a dealer at customer expense. Key programming is not a warranty item. A maximum of 8 random code keys can be programmed. If a key is lost, all remaining keys must be reprogrammed with the replacement key. (see optional equipment illustrations section)
6C7	LAMP, AUXILIARY DOME - Red and white LED dome lamp is located on the headliner between front row seats. Wired independently from standard dome lamp
UEO	OnStar DELETE - Standard Bluetooth functionality remains. OnStar 4G LTE is deleted when UEO OnStar Delete is ordered
JF4	PEDALS - Power-adjustable for accelerator and brake
6N6	REAR DOOR LOCKS AND HANDLES INOPERATIVE - Rear power locks are inoperable at rear door but operate from drivers position, rear doors can be opened only from outside the vehicle
6N5	REAR DOOR WINDOW SWITCHES INOPERATIVE - Rear windows only operate from drivers position
UJ5	REAR SEAT DVD ENTERTAINMENT SYSTEM - Includes dual DVD headrests and two analog headphones (dealer-installed). It is "A/D" on PPV 1FL and Special Service 1FL
SFJ	REFLECTIVE WINDOW SHADE
BTV	REMOTE VEHICLE STARTER SYSTEM - Includes remote keyless entry
A95	SEAT & CENTER CONSOLE - Driver and Passenger Front Bucket Cloth Seats, with integrated retail console. 10-way Power Driver and Passenger Seats. Includes (AYQ) Airbags ¹ , Frontal airbags for driver and front outboard passenger; Seat-mounted side-impact airbags for driver and front outboard passenger; Driver inboard seat-mounted side-impact airbag (requires bucket seats); Head-curtain airbags for all rows in outboard seating positions Not recommend for vehicles intended to be up-fitted with aftermarket equipment
5T5	SEAT - Front cloth with vinyl rear seat (see front seats and interior trim illustration page for description)
9U3	SEAT DELETE FRONT CENTER - 20% center section removed, Power driver and passenger bucket seats in base cloth trim. Derived from RPO (AZ3) 40-20-40 split bench seat with the 20% section removed. Does not include a floor console. All exposed floor area will remain untrimmed. Not available with (A95) Bucket Seats. A separate cable connection kit for the USB, Auxiliary Jack and Auxiliary Power is provided in the vehicle when the center seat section is deleted for installation by customer/upfitter in aftermarket console
VRS	SHADE - Cargo security

1. Always use seat belts and child restraints. Children are safer when properly secured in a rear seat in the appropriate child restraint. See the Owner's Manual for more information.

EXTERIOR

B86	BODY SIDE LOWER DOOR MOLDINGS - Body-color. Not available with (TGK) Special paint or (B85) bright bodyside moldings
B85	BODY SIDE LOWER DOOR MOLDINGS - Bright bodyside. Not available with (B86) body-color bodyside moldings
SFZ	CHEVY BOWTIE BLACK - Front grill and rear tailgate emblems
9G8	DELETE DAYTIME RUNNING LAMPS AND AUTOMATIC HEADLAMPS - Exterior lamps are operated manually and automatic headlamps deleted. (See Surveillance Feature Manual Lamp Control in standard illustration section)
R88	EMBLEM - Black illuminated front bowtie emblem (includes Black illuminated front bowtie and Black non-illuminated rear bowtie)
5T4	EXTERIOR BODY COLOR PARTS - SEO 5T4 Exterior body colored parts. Victory Red special painted exterior body parts in lieu of glossy Black color normally installed with special painted bodies, Victory Red painted parts will consist of front fascia, rear bumper fascia, rear liftgate handle, and door handles. Mirrors, rear D-pillar appliqué and liftgate spoiler will remain Black. Requires SEO (TGK) special paint solid, special paint color Victory Red WA-9260 and (V76) recovery hooks
9V2	EXTERIOR BODY COLORED PARTS - Blue WA-5665 applied to front and rear fascia all other non-metal body parts will remain black, same as (TGK) special paint solid. Includes opening in front fascia without recovery hooks (requires TGK special paint solid) Recovery hooks (V76) optional
6J7	FLASHER SYSTEM HEADLAMPS AND TAIL LAMPS - DRL compatible, headlamp flasher module with control wire to permit separate front and rear lamp flashing
AKP	NON-TINTED GLASS - Solar absorbing (replaces deep-tinted glass on rear doors and cargo area)
VK3	LICENSE PLATE - Front mounting package (included on orders with ship-to states that require front license plate) (see optional equipment illustrations section)
VLG	REAR-FASICA CLOSEOUT - Available with (GAN) Silver Ice Metallic, (GJI) Shadow Gray Metallic, (GAZ) Summit White or (GBA) Black exterior colors. Not available with (S6N) Trailer hitch insert
V76	RECOVERY HOOKS, BLACK - Two front frame-mounted. Required on all models sold to Alaska, Guam, Hawaii, Puerto Rico and Virgin Islands. All Tahoe 9C1 Police and 5W4 Special Service Vehicles will include front fascia recovery hook openings but does not include the hooks. See optional equipment illustrations section. NOTE: Front recovery hooks are for vehicle recovery only. To avoid the risk of injury, never use recovery hooks to tow a vehicle
TGK	SPECIAL PAINT SOLID - One color all normally body-colored non-sheet metal parts will be gloss Black. This includes front and rear facias, liftgate handle and applique, D-pillars and upper liftgate applique. Mirrors and door handles will be grained Black parts. B85 body-side moldings are not available except with SEO option 5T4 exterior body-colored parts. Required with any SEO paint selection may require extended lead time
VQK	SPLASH GUARDS - Molded black
7X6	SPOTLAMP - Left hand, separately fused, Not available with (7X7) left and right-hand spotlamps (see optional equipment illustrations section)
7X7	SPOTLAMPS - Left and right hand, separately fused (see optional equipment illustrations section) NOTE: Factory installation of spotlamps are recommended. Special tooling is used to locate and drill the spotlamp shaft hole in the pillars. (Interior trim covers provided with factory installed lamps are not available as service parts). Field installation of spotlamps must not interfere with proper deployment of the roof rail mounted head-curtian airbags in the event of a crash
S6N	TRAILER HITCH INSERT - Black rubber square with a logo that closes out the receiver (see optional equipment illustrations section)
Q5U	WHEELS - Bright machined aluminum, 17" x 8" (43.2 cm x 20.3 cm), includes (RM7) 17" x 8" (43.2 cm x 20.3 cm) full-size, steel spare.

ELECTRICAL

WX7	WIRING - For customer connection to front door and windshield pillar speakers. Front speakers are not connected to the vehicle radio; radio audio signals are routed to the rear speakers
6J3	WIRING - For grille lamps and siren speaker
6J4	WIRING - Horn Transfer Loop wire permits customer connection of a switch to operate the vehicle horn or a customer-provided siren system via the steering wheel horn button
UT7	GROUND STUDS - Two interior mounted left and right side M10 studs in cargo area. Driver side includes 5 feet of 8 gauge ground wire.

MECHANICAL

1LR	BRAKE SYSTEM, CITY - Modified Police City Brake Package. Uses base friction material that wears better at lower temperatures and city service. The city brakes are not optimal for track performance. The front rotors are Duralife but do not have the radial drilled holes. The parts are physically interchangeable for service, however the parts should be substituted as complete four wheel sets
R9Y	FLEET FREE MAINTENANCE CREDIT - This option code provides a credit in lieu of the free oil changes, tire rotations and inspections for one maintenance service during 1st year of ownership. The invoice will detail the applicable credit. The customer will be responsible for all oil change, tire rotations and inspections costs for this vehicle. Requires one of the following Fleet or Government order types: FBC, FBN, FCA, FCN, FLS, FNR, FRC or FGO. Not available with FDR order types
K05	HEATER - Engine block
UN9	RADIO SUPPRESSION - Ground Straps

FLEET CONNECTED SERVICES AND OnStar PLANS¹

POJ	ADDITIONAL 21 MONTHS OF FLEET SAFETY & SECURITY PLAN. Provides 21 months of Safety and Security Plan coverage in addition to the 3 months of standard coverage that is included in the price of the vehicle. Total Safety & Security Plan service duration is 24 months. Requires (UE1) OnStar. Requires one of the following: Fleet or Government order types: FLS, FNR, FRC, FBC, FGO or FEF. Not available with POK or POL. Not available with a ship-to of Puerto Rico or the Virgin Islands.
POK	ADDITIONAL 33 MONTHS OF FLEET REMOTE ACCESS PLAN. Provides 33 months of Remote Access Plan in addition to the 3 months of standard coverage that is included in the price of the vehicle. Total OnStar Remote Access Plan service duration is 36 months. Requires (UE1) OnStar. Requires one of the following: Fleet or Government order types: FLS, FNR, FRC, FBC, FGO or FEF. Not available with POM or POO. Not available with a ship-to of Puerto Rico or the Virgin Islands.
POL	ADDITIONAL 45 MONTHS OF FLEET SAFETY & SECURITY PLAN. Coverage provides 45 months of Safety and Security in addition to the 3 months of standard coverage that is included in the price of the vehicle. Total Fleet Safety & Security Plan service duration is 48 months. Requires (UE1) OnStar. Requires one of the following: Fleet or Government order types: FLS, FNR, FRC, FBC, FGO or FEF. Not available with POJ or POK. Not available with a ship-to of Puerto Rico or the Virgin Islands.
POM	ADDITIONAL 21 MONTHS OF FLEET REMOTE ACCESS PLAN. Provides 21 months of Remote Access Plan in addition to the 3 months of standard coverage that is included in the price of the vehicle. Total OnStar Remote Access Plan service duration is 24 months. Requires (UE1) OnStar. Requires one of the following: Fleet or Government order types: FLS, FNR, FRC, FBC, FGO or FEF. Not available with PON or POO. Not available with a ship-to of Puerto Rico or the Virgin Islands.
PON	ADDITIONAL 33 MONTHS OF FLEET REMOTE ACCESS PLAN. Provides 33 months of Remote Access Plan in addition to the 3 months of standard coverage that is included in the price of the vehicle. Total OnStar Remote Access Plan service duration is 36 months. Requires (UE1) OnStar. Requires one of the following: Fleet or Government order types: FLS, FNR, FRC, FBC, FGO or FEF. Not available with POM or POO. Not available with a ship-to of Puerto Rico or the Virgin Islands.
POO	ADDITIONAL 45 MONTHS OF FLEET REMOTE ACCESS PLAN. Provides 45 months of Remote Access Plan in addition to the 3 months of standard coverage that is included in the price of the vehicle. Total OnStar Remote Access Plan service duration is 48 months. Requires (UE1) OnStar. Requires one of the following: Fleet or Government order types: FLS, FNR, FRC, FBC, FGO or FEF. Not available with POM or PON. Not available with a ship-to of Puerto Rico or the Virgin Islands.

GM COMMERCIAL LINK

POG	GM COMMERCIAL LINK - 1 YEAR OF SERVICE. Includes 12 months of GM Commercial Link service. Provides access and reporting for key vehicle information such as speed, location and maintenance through website and mobile application. Eligible customers must sign up for an account at www.gmcommerciallink.com in order take advantage of this 12 month offer. The Commercial Link service is included in the price of the vehicle. Total service duration is 12 months. Non-Transferrable. Non-Refundable. Requires (UE1) OnStar. Requires one of the following: Fleet or Government order types: FLS, FNR, FRC, FBC, FGO or FEF. Not available with (POH) GM Commercial Link - 2 years of Service or (POI) GM Commercial Link - 3 years of Service.
POH	GM COMMERCIAL LINK - 2 YEARS OF SERVICE. Includes 24 months of GM Commercial Link service. Provides access and reporting for key vehicle information such as speed, location and maintenance through website and mobile application. Eligible customers must sign up for an account at www.gmcommerciallink.com in order take advantage of this 24 month offer. The Commercial Link service is included in the price of the vehicle. Total service duration is 24 months. Non-Transferrable. Non-Refundable. Requires (UE1) OnStar. Requires one of the following: Fleet or Government order types: FLS, FNR, FRC, FBC, FGO or FEF. Not available with (POG) GM Commercial Link - 1 year of Service or (POI) GM Commercial Link - 3 years of Service.
POI	GM COMMERCIAL LINK - 3 YEARS OF SERVICE, includes 36 months of GM Commercial Link service. Provides access and reporting for key vehicle information such as speed, location and maintenance through website and mobile application. Eligible customers must sign up for an account at www.gmcommerciallink.com in order take advantage of this 36 month offer. The Commercial Link service is included in the price of the vehicle. Total service duration is 36 months. Non-Transferrable. Non-Refundable. Requires (UE1) OnStar. Requires one of the following: Fleet or Government order types: FLS, FNR, FRC, FBC, FGO or FEF. Not available with (POG) GM Commercial Link - 1 year of Service or (POH) GM Commercial Link - 2 years of Service.

1. Services subject to user terms and limitations. Certain services require working electrical system, cell reception and GPS signal. OnStar links to emergency services. Data plans offered by AT&T. See gmfleet.com/connected services for details. Availability subject to change

POWERTRAIN

ENGINE				TRANSMISSION		AXLE	
OPTION CODE	TYPE	DISPLACEMENT LITERS/CU. IN.	FUEL SYSTEM	OPTION CODE	TYPE	OPTION CODE	RATIO
L83	V8	5.3/325	Active fuel management Flex Fuel ¹	MXO/MYC	6L80 6-speed auto. with OD	GU4	3.08

EMISSIONS - MUST BE SPECIFIED

FE9	FEDERAL EMISSIONS , Use for ordering vehicles that will be registered in all states except California, Connecticut, Delaware, Maine, Maryland, Massachusetts, New Jersey, New York, Oregon, Pennsylvania, Rhode Island, Vermont and Washington State.
YF5	CALIFORNIA EMISSIONS , Use for ordering vehicles that will be registered in California.
NE1	EMISSIONS , Use for ordering vehicles that will be registered in Connecticut, Delaware, Maine, Maryland, Massachusetts, New Jersey, New York, Oregon, Pennsylvania, Rhode Island, Vermont or Washington State.
NB8	EMISSIONS , Required when option code FE9 "FEDERAL EMISSIONS" is ordered for delivery to a dealer located in California, Connecticut, Delaware, Massachusetts, Maryland, New Jersey, New York, Oregon, Pennsylvania, Rhode Island and Washington State for a purchaser who will be registering the vehicle outside California, Connecticut, Delaware, Maine, Maryland, Massachusetts, New Jersey, New York, Oregon, Pennsylvania, Rhode Island, Vermont and Washington State. Do not use for vehicles that will be registered in California, Connecticut, Delaware, Maine, Maryland, Massachusetts, New Jersey, New York, Oregon, Pennsylvania, Rhode Island, Vermont and Washington State.
NC7	EMISSIONS , Required when option code YF5 "CALIFORNIA EMISSIONS" or option code NE1 "CT/DE/ME/MD/MA/NJ/NY/OR/PA/RI/VT/WA EMISSIONS" is ordered for delivery to a dealer located in any state except California, Connecticut, Delaware, Maine, Maryland, Massachusetts, New Jersey, New York, Oregon, Pennsylvania, Rhode Island, Vermont and Washington State for a purchaser who will be registering the vehicle in one of these states or sold as permitted below under "EPA Policy on the Sale of California Emission Vehicles".
NB9	EMISSIONS , Required when option code YF5 is ordered for delivery to a dealer located in Connecticut, Delaware, Maine, Maryland, Massachusetts, New Jersey, New York, Oregon, Pennsylvania, Rhode Island, Vermont and Washington State. Required when option code NE1 is ordered for delivery to a dealer located in California.

NOTE: The 2020 Chevrolet Tahoe Police Patrol Vehicle and Special Service Vehicle with the 5.3L Engine (L83) with Emission Option Codes: FE9 NAME CERTIFICATION EMISSION, FEDERAL NE1 NAME CERTIFICATION EMISSION, GEOGRAPHICALLY RESTRICTED YF5 NAME CERTIFICATION EMISSION, CALIFORNIA is certified to EPA Tier 3 BIN 125 standards and qualifies as ULEV 125 (Ultra Low Emission Vehicle) under California Air Resources Board (CARB) requirements, meaning it is 50-state certified. EPA engine family or test group: KGMXT05.3382

TIRES V-SPEED RATED

MANUFACTURER	QUANTITY	SIZE	SPEED RATING	TYPE
GOODYEAR	5	P265/60R17	V	All season BW

NOTE: Due to specific requirements for performance durability and safety, GM recommends only the original equipment tires for replacement
Tire Plies = Tread 6 ply; 2 Polyester, 2 Steel, 2 Nylon, Sidewall, 2 Polyester

Tire Chains - Follow that manufacturer's instructions. To avoid vehicle damage, drive slow and readjust or remove the traction device if it is contacting the vehicle. Do not spin the wheels. If traction devices are used, install them on the rear tires. If the vehicle has P255/70R17 or P265/70R17 size tires, use tire chains only where legal and only when necessary. Use chains that are the proper size for the tires. Install them on the rear tires only. Do not use chains on the front tires. Tighten them as tightly as possible with the ends securely fastened. Drive slowly and follow the chain manufacturer's instructions. If the chains contact the vehicle, stop and retighten them. If the contact continues, slow down until it stops. Driving too fast or spinning the wheels with chains on will damage the vehicle.

If the vehicle has 265/65R18, P265/65R18, P275/55R20, or P285/45R22 size tires, do not use tire chains. There is not enough clearance. Tire chains used on a vehicle without the proper amount of clearance can cause damage to the brakes, suspension, or other vehicle parts. The area damaged by the tire chains could cause loss of control and a crash. Use another type of traction device only if its manufacturer recommends it for the vehicle's tire size combination and road conditions.

1. E85 is 85% ethanol and 15% gasoline.

SPECIFICATIONS

Specifications shown are for Police and Special Service Vehicles only which differ from retail civilian models

GENERAL

Model	CC15706
Drive	2-wheel
Projected top speed (without equipment)	134 mph
Projected top speed in reverse (without equipment)	49 mph

NOTE: Adding non dealer accessories or making modifications to the vehicle can affect vehicle performance, aerodynamics, and overall top speed.

EXTERIOR (in./mm)

Wheelbase	116.0/2946
Overall length	204.0/5182
Body width (without mirrors)	80.5/2045
Overall height*	72.4/1839
Lift in height* (Top of load floor to ground)	35.9/912
Step-in height	22.0/559
Front track width	68.7/1745
Rear track width	68.7/1744
Turning diameter curb to curb (ft./m)	39.0/11.9
Ground clearance* (rear axle)	8.5/216
Air intake height*	37.4/950

*Published dimensions indicated are at Base Curb Weight

FRONT COMPARTMENT (in./mm)

Head room (Maximum)	42.8/1087
Shoulder room	64.8/1646
Hip room	60.8/1544
Leg room (Maximum)	45.3/1151

REAR COMPARTMENT (in./mm)

Head room	38.7/983
Shoulder room	65.1/1654
Hip room	60.2/1529
Leg room	39.0/991

CARGO

Load floor length to center of front seat at floor (in./mm)	79.9/2029
Load floor length to center of 2nd seat at floor at seat (in./mm)	43.2/1097
Inside width between wheel house (in./mm)	49.3/1252
Cargo area height (in./mm)	40.9/1039
Cargo volume ¹ maximum behind front seat (cu. ft./liters)	112.1/3174
Cargo volume ¹ maximum behind second seat (cu. ft./liters)	54.0/1530

NOTE: For additional dimensional data go to: www.gmupfitter.com

PASSENGER COMPARTMENT

VOLUME INDEX (cu.ft./liters)

Passenger compartment volume index	120.7/3418
------------------------------------	------------

EPA-ESTIMATED MPG FUEL ECONOMY RATINGS

5.3L engine 2WD (City/Highway/Combined)	15/22/18
---	----------

VEHICLE WEIGHT (lbs./kg.)

Seat Type	40/20/40 Standard	40/40 Optional
GVWR ² (Gross Vehicle Weight Rating)	6800/3084	6800/3084
FGAWR (Front Gross Axle Weight Rating)	3250/1474	3250/1474
RGAWR (Rear Gross Axle Weight Rating)	3700/1678	3700/1678
Payload ³	1550/703	1588/720
Base curb weight	5223/2369	5185/2352
Maximum Trailering Capacity ⁴	4000/1814	4000/1814

NOTE: See Vehicle Load Limits in your Owner's Manual and Owner's Manual Supplement for loading information.

1. Cargo and load capacity limited by weight and distribution.
2. Gross Vehicle Weight Rating (GVWR). When properly equipped, includes vehicle, passengers, cargo and equipment.
3. These maximum payload ratings are intended for comparison purposes only. Before you buy a vehicle or use it to haul people or cargo, carefully review the vehicle loading section of the Owner's Manual and check the carrying capacity of your specific vehicle on the label on the inside of the driver's door jamb.
4. Before you buy a vehicle or use it for trailering, carefully review the Trailering section of the Owner's Manual. The weight of passengers, cargo and options or accessories may reduce the amount you can tow

SPECIFICATIONS

Specifications shown are for Police and Special Service Vehicles only which differ from retail civilian models

ENGINE	STANDARD
Type	EcoTec3 V8
Displacement: liters/cu. in.	5.3/325
Horsepower/rpm	355 @ 5600
Torque lb.-ft./rpm	383 @ 4100
Induction system	Direct Injection
Compression ratio	11.0:1
Exhaust	Single
Minimum recommended fuel octane	87
Approximate fuel tank capacity (gallons/liters)	26/98
Oil with filter (quarts/liters)	8.0/7.6
Cooling capacity (quarts/liters)	18.1/17.1

TRANSMISSION	
Automatic electronic with overdrive	6-speed
Fluid pan removed and filter replaced (quarts/liters)	6.0/5.7

AXLE	
Ratio	3.08

BRAKES	
ABS with vacuum-boost	Disc/Disc
Front-swept area (sq. in./sq. cm)	256.6/1655
Rear-swept area (sq. in./sq. cm)	248/1600
Total front and rear swept area (sq. in./sq. cm)	504.6/3255
Front rotor diameter (in./mm)	13.0/330
Rear rotor diameter (in./mm)	13.5/345
Front rotor thickness (in./mm)	1.2/30
Rear rotor thickness (in./mm)	.79/20

TIRES	
Type	Goodyear V-rated all-season
Size	P265/60R17

WHEELS	
Type	Steel
Size	17" x 8"

CHASSIS	
Frame	Full perimeter steel
Front suspension	SLA (Short Long Arm) with coil over shock and stabilizer bar
Rear suspension	Multi-link, coil springs and stabilizer bar
Steering type	Electric power-assisted rack and pinion
Steering ratio	17.75:1

BATTERIES	PRIMARY	AUXILIARY
Type	Maintenance free	Maintenance free
BCI group size	LN4	LN3
Volts	12	12
Amp hour rating	80	70
Cold cranking-amps @ 0°F (-18°C)	720	730

ALTERNATOR	
Type	Denso SC3
Amps	77°F (25°C) 170

TAHOE POLICE ALTERNATOR OUTPUT

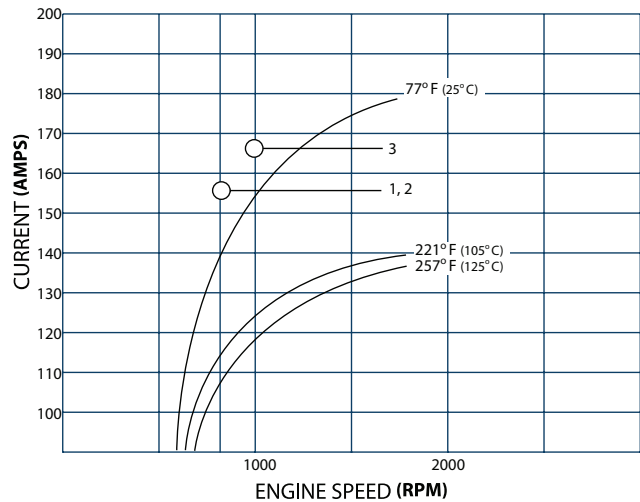

BOOST LEVEL	PARK/NEUTRAL	DRIVE
Normal Idle	550	500
1	800	650
2	800	725
3	1000	800

DIMENSIONS

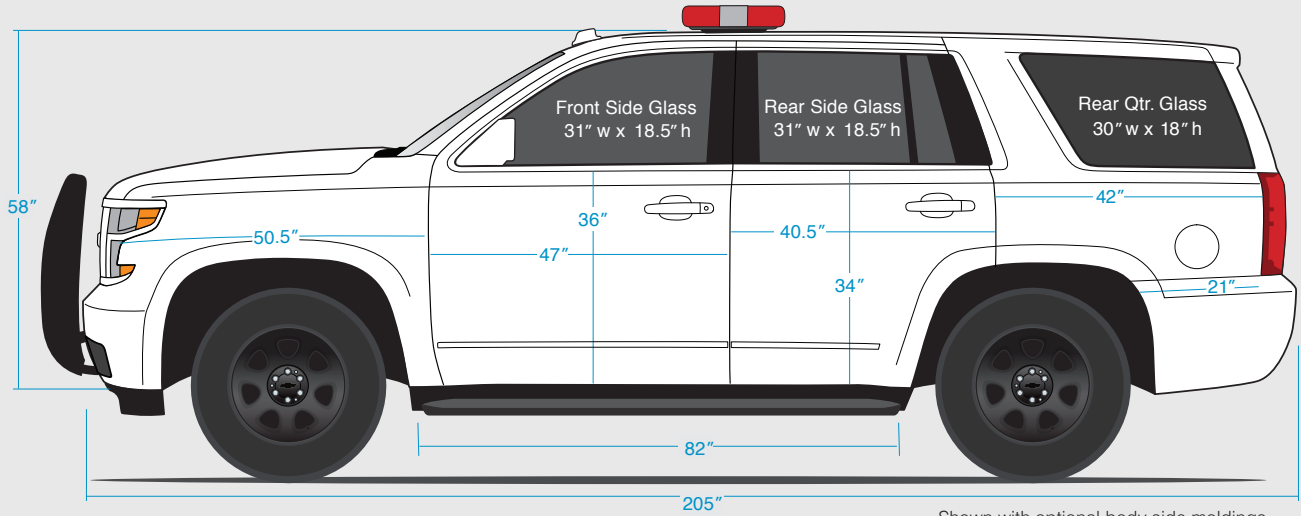

Shown with optional body side moldings

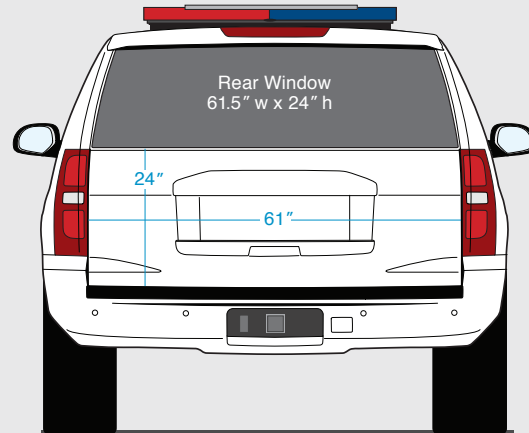
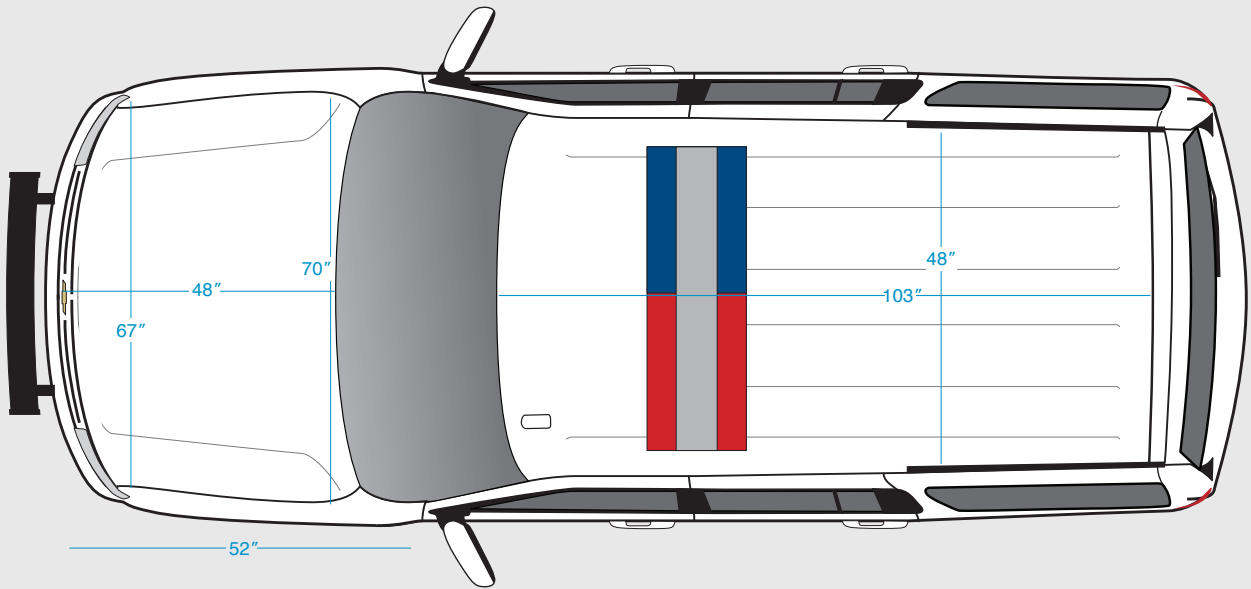

Estimated material sizes to wrap:

- Hood – 72" x 52"
- Front Doors – 50" x 38"
- Rear Doors – 42" x 36"
- Roof – 110" x 55"
- Rear hatch – 63" x 26"

VEHICLE LOAD LIMITS

This information is intended for those who intend to install additional equipment on the police vehicle after it has left the factory, and for those who will be driving and loading the vehicle with passengers and/or cargo. Two labels on your vehicle show how much weight it was designed to carry, the Tire and Loading Information label and the Certification/Tire label. These labels are attached to your vehicle and give you the maximum load capacity, the Gross Vehicle Weight Rating (GVWR) and the Gross Axle Weight Rating (GAWR) for your vehicle. See "Vehicle Load Limits" in the owner manual Index for additional loading information.

The following guidelines can help you with proper loading and load distribution when installing additional equipment on the Tahoe Police Package.

WARNING

DO NOT LOAD THE VEHICLE ANY HEAVIER THAN THE GROSS VEHICLE WEIGHT RATING (GVWR), NOR EITHER THE MAXIMUM FRONT OR REAR GROSS AXLE WEIGHT RATING (GAWR). THIS CAN CAUSE SYSTEMS TO BREAK AND CHANGE THE WAY THE VEHICLE HANDLES. THIS COULD CAUSE LOSS OF CONTROL AND A CRASH. OVERLOADING CAN ALSO SHORTEN THE LIFE OF THE VEHICLE.

ADDING EQUIPMENT TO YOUR VEHICLE

Before adding accessories or equipment to your police vehicle, there are some things you need to know

- The police vehicle's maximum capacity weight (payload). The weight of your police vehicle, including a full tank of fuel but without a driver and passengers.
- The weight of items you plan on adding to your police vehicle, like roof mounted light bar(s), push bumpers, security barrier(s), rear storage organizer, highway flares, fire extinguishers, weapons, ammunition, radios, and video equipment.
- The weight and number of passengers you intend to carry in your vehicle.
- The total weight of any additional cargo you intend to carry in your vehicle.

When planning your vehicle equipment installation remember not to exceed the Gross Vehicle Weight Rating (GVWR) or the Gross Axle Weight Rating (GAWR) of the front or rear axles. To keep the available load weight less than the vehicle capacity weight, you may need to limit the number of passengers you carry in your vehicle or change your choice of additional equipment. Towing a trailer may change the vehicle payload capacity.

CENTER OF GRAVITY (CG)

A vehicle's center of gravity is an imaginary location inside the vehicle and is a balance point for the vehicle mass as it moves down the road. The police vehicle's center of gravity, before you add a load and passengers, is approximately midway between the center of the axles, up from the ground to just below the front window, and between the driver and passenger. Equipment location and weight on the vehicle's center of gravity is important to keep in mind when planning an installation. Heavy equipment should be positioned as low and as far forward in the rear load compartment as possible. Try to mount the equipment below the bottom of the side windows. Refer to the Loading Zone chart and diagram to help with your installation plan.

A procedure to make the necessary measurements and formulas to calculate the vehicle longitudinal, lateral and vertical position of the center of gravity can be found in the GM Coachbuilders Manual.

Equipment required to conduct the measurements for calculating the center of gravity are:

- Weight scales of sufficient capacity to measure the vehicle weight at each wheel.
- A post type hoist or other means to safely elevate the front of the vehicle to at least an angle of 20 degrees above horizontal.

See your GM dealer to get more information about this coachbuilder procedure.

Keeping the center of gravity midway between the axles is also important to provide proper braking performance. About half the total vehicle weight on each axle is recommended.

Weigh your vehicle after the additional equipment has been installed to determine the actual weight of your vehicle. Weigh the vehicle with a full tank of fuel and without passengers. You may need to put a limit on how many people or other equipment you can carry inside your vehicle after the additional equipment has been installed.

Note: See loading zone weight chart and diagram

LOADING ZONES

Loading zones for customer installed equipment and cargo with six occupants
Refer to your vehicle tire placard for Vehicle Seating Capacity and Payload Capacity (Occupants + Cargo) Weight

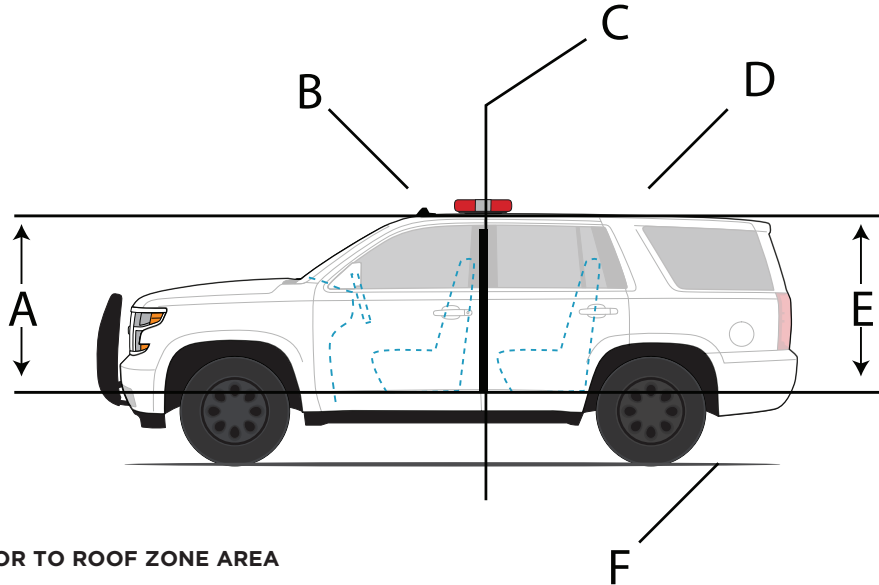

- A. FRONT FLOOR TO ROOF ZONE AREA
- B. FRONT ROOF ZONE AREA
- C. BACK OF FRONT DOOR
- D. REAR ROOF ZONE AREA
- E. REAR FLOOR TO ROOF ZONE AREA
- F. GROUND

LOADING ZONE WEIGHT CHART TAHOE POLICE PACKAGE 2WD 9C1

LOADING ZONES	FRONT AXLE WEIGHT	REAR AXLE WEIGHT	TOTAL
ROOF	25 LBS (11 KG)	34 LBS (15 KG)	59 LBS (26 KG)
FLOOR TO ROOF	91 LBS (41 KG)	360 LBS (163 KG)	451 LBS (204 KG)
TOTAL	116 LBS (52 KG)	394 LBS (178 KG)	510 LBS (230 KG)

NOTE:

CARGO WEIGHT CAN BE GREATER WITH FEWER OCCUPANTS. TOWING A TRAILER MAY CHANGE VEHICLE PAYLOAD

REFER TO YOUR OWNER'S MANUAL SUPPLEMENT FOR DETERMINING MAXIMUM CARGO LOADING AND POSITIONING.

USING HEAVIER SUSPENSION COMPONENTS TO GET ADDED DURABILITY MIGHT NOT CHANGE YOUR WEIGHT RATINGS AND MAY AFFECT THE VEHICLE PERFORMANCE AND HANDLING CHARACTERISTICS.

HIGH SPEED OPERATIONS SHOULD NOT BE ATTEMPTED WITH AN IMPROPERLY OR OVERLOADED VEHICLE OR WHILE TOWING A TRAILER.

YOUR GM DEALER CAN PROVIDE HELP WITH PROPERLY LOADING YOUR VEHICLE.

STANDARD WHEEL



Goodyear P265/60R17 V-rated all season tire mounted on 8.5" black steel wheel with bolted on center cap and matching spare wheel.

OPTIONAL WHEEL



Goodyear P265/60R17 V-rated all season tire mounted on aluminum wheel. Full size spare tire mounted on black steel wheel (does not include center cap).

STANDARD EQUIPMENT

WIRING PROVISIONS FOR 12-VOLT BATTERY POWER SUPPLY

The vehicle is equipped with wiring provisions for connecting 12-volt battery power to customer installed equipment. Refer to the following information when adding electrical accessories that will use the 12-volt power supply circuits connected to the vehicle's electrical system. A wiring harness is located below the instrument panel (IP) near the center of the vehicle and another connection point is located in the left rear of the cargo area.

The 12-volt battery power for customer connection is supplied from the Primary vehicle battery via control relays to four blunt cut 30-amp circuit wires and from an Auxiliary battery via one blunt cut 50 -amp circuit wire in the harness under the center IP. A blunt cut ground wire is also included in the front harness. A 100-amp Rear Electrical Center (REC) stud is located in the left rear cargo area.

The Primary battery is located at the right rear of the engine compartment and the Auxiliary Battery is located at the left front of the engine compartment. The Auxiliary Battery is connected to the vehicle charging system via a relay which is closed when the ignition is ON.

Four 30-amp control relays and 30-amp fuses are located in the Underhood Electrical Center (UEC).

Also in the UEC are two 5-amp fuses which connect control relay coils 1 & 2 and control relay coils 3 & 4 to the UEC primary battery bus. Refer to the UEC label showing the 5-amp fuse locations 69 and 77, labeled "R/C" for Run/Crank power and locations 70 and 78, labeled "V/Batt" for primary battery power.

The 5-amp fuses for the control relays can be positioned to operate all relays from the ignition buss or primary battery buss or one pair on ignition and one pair on battery. See also Bulletin #118 at www.gmupfitter.com.

The four control relays are operated via separate blunt-cut wires located in the harness under the instrument panel and are intended to be connected via customer switching to vehicle ground.

Blunt cut ignition control and signal wires are also in the harnesses under the center IP and between the front seats.

The auxiliary power control relay control wires and the relay contact 30-amp load side wires for customer connection are identified as follows:

Control Relay Ground control wires:

- Red/White...Control relay 1
- Yellow/White...Control relay 2
- Green/Grey...Control relay 3
- White/Blue...Control relay 4

12-volt, 30-amp load wires:

- Blue...Control relay 1
- Grey/Black...Control relay 2
- Yellow/Brown...Control relay 3
- Red/Green...Control relay 4
- A Violet/Yellow circuit wire, hot in ACCESSORY/RUN. This circuit is also provided in a coil in the cargo area near the REC.
- A Violet/White circuit wire, Hot in RUN/CRANK. This circuit is also provided in a coil in the cargo area near the REC.
- A Yellow/Black circuit wire, transmission in Park signal. The circuit provides switched 12-volt power when the transmission control is in Park and the engine is running. The circuit is at 0 volts when the transmission control is in any other position, i.e., R, N, D, L. Note that the circuit is at 12-volts when the transmission is in Park and the ignition is in LOCK/OFF. To avoid the possibility of undesired parasitic electrical load when the ignition is OFF, it is recommended that the Park Signal circuit be isolated by a customer furnished ignition control relay.
- A Green/Gray circuit wire for Vehicle Speed signal providing 4000 pulses per mile. The vehicle Electronic Brake Control Module (ECBM) Vehicle Speed Signal (VSS) output circuitry does not include a logic pull-up resistance. If a pull-up resistance is not part of the customer equipment VSS input connection circuitry, a 5000 ohm resistor can be connected between the vehicle VSS circuit wire and vehicle battery power.
- A White/Blue circuit wire for 12-volts when the Service Brakes are applied.
- Blue/White wire provides a pulsating 12 volt signal when a left turn is selected
- A Yellow/Gray wire provides a pulsating 12 volt signal when a right turn is selected
- All automatic lighting can be disabled when a ground is applied via a customer-furnished wire terminated in BCM connector X2, terminal 18

A 100-amp battery voltage stud for customer connection is located in the REC at the left rear of the cargo area. The ACCESSORY/RUN (Violet/Yellow) and RUN/CRANK (Violet/White) circuits are coiled near the REC.

NOTE : Vehicles equipped with (A95) Bucket Seats will have to remove trim to access wiring

NOTE: Wiring connection or splice changes are to be removed before the vehicle is returned to civilian use.

AUXILIARY BATTERY POWER REAR ELECTRICAL CENTER

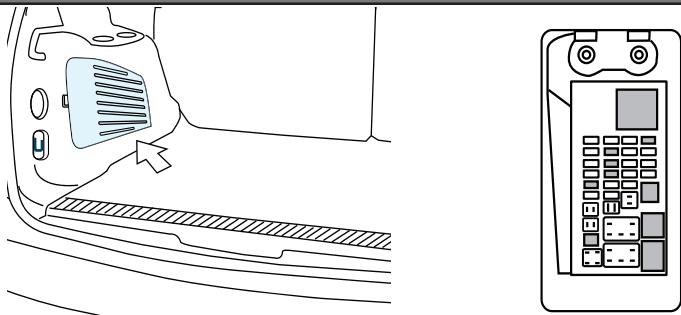

A 100-amp battery voltage stud is located in the Rear Electrical Center (REC) at the left rear of the cargo area. Removal of the vented trim cover in the lower left quarter trim panel provides access to the REC, located to the rear of the jack stowage compartment. A blunt cut ACCESSORY/RUN (Violet/Yellow) circuit wire and a blunt cut RUN/CRANK (Violet/White) circuit wire are coiled near the REC. The nut on the power stud must be torqued to 9Nm+0.5 when attaching other wires to the stud. The stud adjacent to the rear of the 100 amp power stud is inactive.

NOTE: Wiring connection or splice changes are to be removed before the vehicle is returned to civilian use.

TIRE PRESSURE MONITOR WITH TIRE FILL ALERT

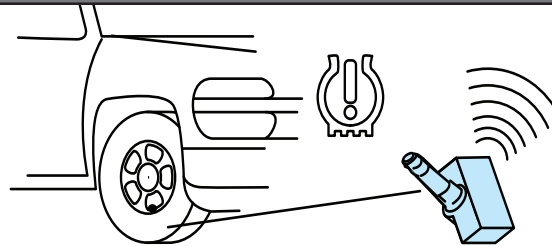

The Tahoe Police Package is equipped with Tire Pressure Monitor System (TPMS) which warns of low tire pressure. The Tahoe Police Package has a full size spare tire with a TPMS sensor which does not read spare tire pressure. When the spare tire from your vehicle or an unused spare tire from another Police Package is placed in use as a road wheel, the system will not read the presence of the new TPM sensor and must be calibrated. Refer to your owner's manual for additional information the Tire Pressure Monitor System Programming.

Tire Fill Alert in addition to the DIC warning when a tire has low pressure, this feature provides audible and visual indication when air is being added to the low tire to aid in achieving optimal tire pressure.

STANDARD EQUIPMENT

SERVICE PARTS IDENTIFICATION LABEL

SPID Label Content Now Included with Certification Label. The Service Parts Identification (SPID) label, often located in the trunk or glovebox of a vehicle, lists a vehicle's VIN, RPO codes and other information that identify the content of the vehicle. Beginning with the 2018 model year, much of this information will be available through a QR code on the Certification label.



Software to read the QR code is commonly available for any Android, iPhone or Windows smartphone. Many basic applications can be downloaded for free. Tested QR code readers that are easy to use include NeoReader by NM LLC, inigma by 3Gvision, QR Scanner by Honestly App, QR Droid by DroidLa and Bar-Code by PW2. GM does not recommend any particular software. Once the QR code is scanned, the vehicle information will appear in the following order: VIN, Model Year, Model, Build Month, Year, Engineering Book, Vehicle Order Number, 3 Digit RPO Codes sorted alphanumerically, and the Paint Code (same code appears in the lower left of the QR code).

LH INSTRUMENT PANEL FUSE BLOCK

50 amp Fuse for APO's.
Left Fuse Position (5) for
Battery Powered APO's.
Right Fuse Position (6) for
Ignition controlled APO Power.

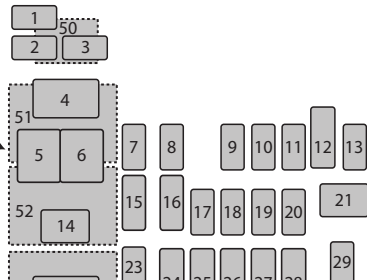

USB AND AUXILIARY JACK LOCATION

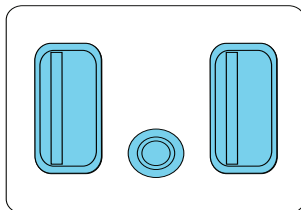

Vehicles ordered with Option 9U3, Delete Center Seat, will have a separate cable connection kit provided in the vehicle for the USB, Auxiliary Jack and Auxiliary Power connection.

SURVEILLANCE FEATURE MANUAL LAMP CONTROL AND 9G8

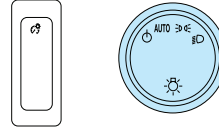

The headlamp control on the driver's side of the instrument panel operates the exterior lamps. If your Tahoe does not have option 9G8, DELETE DAYTIME RUNNING LAMPS and AUTOMATIC HEADLAMPS, the Daytime Running Lamps and Automatic Headlamps can be turned OFF for one ignition cycle by rotating the headlamp control knob momentarily counter-clockwise. See also Section 3 of your Tahoe Owner's Manual.

Surveillance Feature - The Body Control Module (BCM) has been calibrated to provide disabling of the exterior and interior automatic lighting. The BCM is located under the instrument panel to the left side of the steering column. The Surveillance Feature can be connected by installing a terminated wire in cavity 18 of the Light Blue colored BCM connector, X2. The wire and terminal part number to be installed is GM #13582297. When a customer-provided terminated wire is properly installed in X2-18 and the wire is connected via a customer-provided switch to vehicle ground, automatically controlled lighting is disabled or dimmed to minimum Federally regulated level.

Option SEO 9G8 - Delete Daytime Running Lamps and Automatic Headlamps. This option disables the Daytime Running Lamps and Automatic Headlamps control feature. Exterior lamps are only manually controlled (Option 9G8 is not available in Canada).

When the headlamp switch is in Auto with 9G8 installed, the instrument cluster, radio display and air conditioning illumination remains at daytime intensity and are dimmable only when the headlamp switch is rotated to the Parking Lamps or Headlamps positions. If SEO 9G8 is not installed, the displays are dimmable with the Headlamp switch in the AUTO position. The instrument cluster, radio and AC displays will dim if the Surveillance Feature is activated as described above.

Interior courtesy lamps, including dome lamps, can be turned OFF with a three-position switch located in the front overhead console. The interior lamp control positions are: OFF - DOOR - ON. When the switch is in the OFF position, all interior lighting remains off whenever the doors or liftgate are opened.

NOTE: Wiring connection or splice changes are to be removed before the vehicle is returned to civilian use.

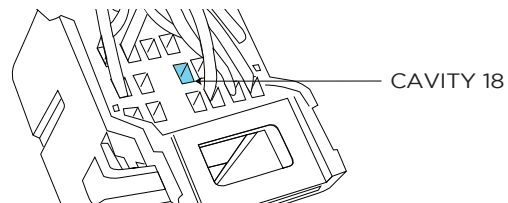

STANDARD EQUIPMENT

TRANSMISSION OIL COOLER

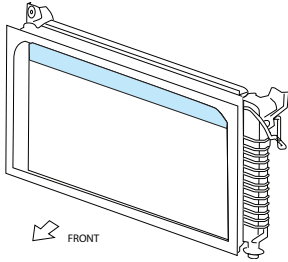

Transmission oil is pumped from the transmission through piping to an internal oil-to-coolant heat exchanger in the left side radiator end tank, then through piping to an oil-to-air heat exchanger in the upper portion of the air conditioning condenser tubing, and returns to the transmission. The air conditioning condenser is located in front of the engine coolant radiator as part of the Cooling Fan and Radiator Module (CRFM) assembly.

ENGINE OIL COOLER



Engine Oil and Transmission Oil are cooled by passing the fluids through separate coolers located in the engine radiator assembly end tank and the air conditioning condenser. Engine oil is pumped by the engine oil pump from the right side of the engine block through piping to an oil-to-coolant heat exchanger located within the right side end-tank of the coolant radiator and returned to the engine. See also TRANSMISSION OIL COOLER.

ROUTING GROMMET

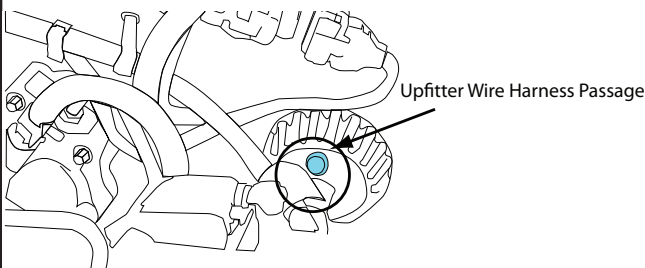

Provides pass through for small number of wires and is located at the lower left side of the front of dash. Carefully remove or puncture only the nipple portion for passage of wire and silicone seal around the wire after installation. Note that a vehicle harness connector is located at the interior side of the grommet and may interfere with passage of wire.

UNDERBODY SHIELD, FRONT

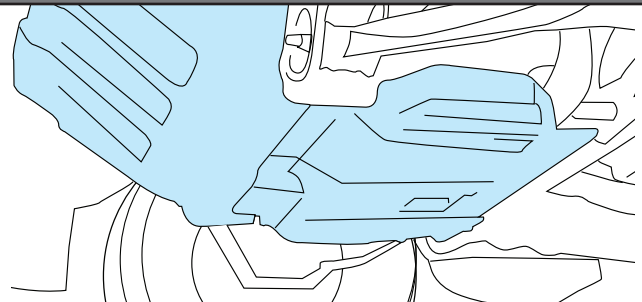

Two piece aluminum front underbody shield starting behind the front bumper and running to the 2nd cross-member protecting front underbody and oil pan.

ELECTRIC POWER STEERING SYSTEM

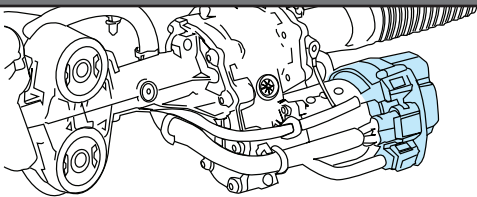

The Electric Power Steering System consists of a Rack-and-Pinion steering gear assisted by an electronically controlled power steering motor and drive assembly. The steering gear is mechanically connected to the steering wheel system.

STANDARD EQUIPMENT

STABILITRAK CONTROL

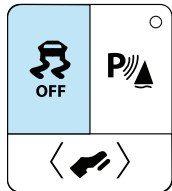

The StabiliTrak Stability Control System control button is located to the left of the steering column on the instrument panel. Button shown is with the optional power adjustable pedals. See also Ride Control Systems in your Owner's Manual for an operation description of the stability control system and related Driver Information Center messages.
(See StabiliTrak section for description)

REAR PARK ASSIST



Rear Park Assist (RPA) uses sensors on the rear bumper to assist with parking and avoiding objects while in R (Reverse). It operates at speeds less than 5 mph (8 km/h). Rear Park Assist may display a warning triangle on the Rear Vision Camera screen and a graphic on the instrument cluster to provide the object distance. In addition, multiple beeps may occur if very close to an object. The Rear Vision Camera displays a view of the area behind the vehicle on the radio screen display, when the vehicle is shifted into R (Reverse).

OnStar®



- Voice Command Button
- Blue OnStar® Button
- Emergency Button

This vehicle is equipped with a comprehensive, in-vehicle system that can connect to a live OnStar® Advisor for Emergency, Security, Navigation, Connection, and Diagnostic Services. OnStar® services may require a paid subscription. OnStar® requires the vehicle battery and electrical system, cellular service, and GPS satellite signals to be available and operating. OnStar® acts as a link to existing public emergency service providers. OnStar® may collect information about you and your vehicle, including location information. See OnStar®'s Terms and Conditions and Privacy Statement for more details including system limitations at www.OnStar.com (U.S.) or www.OnStar.ca (Canada). The OnStar® system status light is next to the OnStar® buttons. If the status light is:

- Solid Green: System is on.
- Flashing Green: On a call.
- Red: Indicates a problem.
- Off: System is off. Press the blue OnStar® button twice to speak with an OnStar® Advisor.

Press or call 1-888-4-ONSTAR (1-888-466-7827) to speak to an Advisor.

Press :

- Make a call, end a call, or answer an incoming call.
- Give OnStar® Hands-Free Calling voice commands.

NOTE: Do not activate OnStar® if you have no plans on using this feature

REAR VISION CAMERA

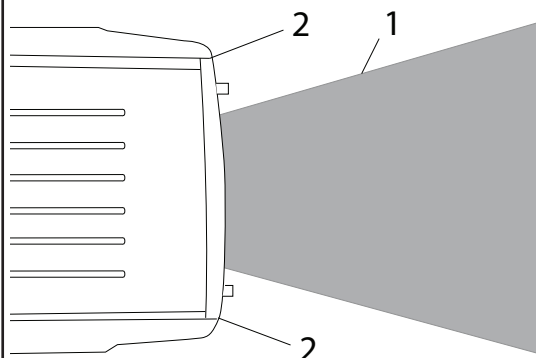

1. View Displayed by the Camera in Radio Screen
2. Corners of the Rear Bumper

Displayed images may be farther or closer than they appear. The area displayed is limited and objects that are close to either corner of the bumper or under the bumper do not display.

A warning triangle may display on the RVC screen to show where the RPA has detected an object. This triangle changes from amber to red and increases in size the closer the object.

The camera(s) do not display children, pedestrians, bicyclists, crossing traffic, animals, or any other object outside of the camera's field of view, below the bumper, or under the vehicle. Shown distances may be different from actual distances. Do not drive or park the vehicle using only these camera(s). Always check behind and around the vehicle before driving. Failure to use proper care may result in injury, death, or vehicle damage.

Note: Safety or driver assistance features are no substitute for the driver's responsibility to operate the vehicle in a safe manner. The driver should remain attentive to traffic surroundings and road conditions at all times. Visibility, weather and road conditions may affect feature performance. Read the Owner's Manual for more important limitations and information.

OPTIONAL EQUIPMENT

PCW ENHANCED DRIVER ALERT PACKAGE

INCLUDES THE FOLLOWING ORDER CODES PLUS JD4 POWER ADJUSTABLE PEDALS

UEU FORWARD COLLISION ALERT



The Forward Collision Alert (FCA) system may help to avoid or reduce the harm caused by front-end crashes. When approaching a vehicle ahead too quickly, FCA provides a red flashing alert on the windshield and rapidly beeps or pulses the driver seat. FCA also lights an amber visual alert if following another vehicle much too closely. FCA detects vehicles within a distance of approximately 60m (197 ft) and operates at speeds above 8 km/h (5 mph).

Warning FCA is a warning system and does not apply the brakes. When approaching a slower-moving or stopped vehicle ahead too rapidly, or when following a vehicle too closely, FCA may not provide a warning with enough time to help avoid a crash. It also may not provide any warning at all. FCA does not warn of pedestrians, animals, signs, guardrails, bridges, construction barrels, or other objects. Be ready to take action and apply the brakes. FCA can be disabled with either the FCA steering wheel control or, if equipped, through vehicle personalization. .

Detecting the Vehicle Ahead FCA warnings will not occur unless the FCA system detects a vehicle ahead. When a vehicle is detected, the vehicle ahead indicator will display green. Vehicles may not be detected on curves, highway exit ramps, or hills, due to poor visibility; or if a vehicle ahead is partially blocked by pedestrians or other objects. FCA will not detect another vehicle ahead until it is completely in the driving lane.

FCA does not provide a warning to help avoid a crash, unless it detects a vehicle. FCA may not detect a vehicle ahead if the FCA sensor is blocked by dirt, snow, or ice, or if the windshield is damaged. It may also not detect a vehicle on winding or hilly roads, or in conditions that can limit visibility such as fog, rain, or snow, or if the headlamps or windshield are not cleaned or in proper condition. Keep the windshield, headlamps, and FCA sensors clean and in good repair.

UHY AUTOMATIC EMERGENCY BRAKING

The brakes may be applied automatically in potential collision situations to help reduce damage or help avoid collisions with vehicles directly ahead.

When the system detects a vehicle ahead in your path that is traveling in the same direction that you may be about to crash into, it can provide a boost to braking or automatically brake the vehicle. This can help avoid or lessen the severity of crashes when driving in a forward gear. Depending on the situation, the vehicle may automatically brake moderately or hard. This forward automatic braking can only occur if a vehicle is detected. This is shown by the Forward Collision Alert.

To set the Automatic Emergency Braking and Forward Collision Alert systems to Alert and Brake, Alert, or Off, go to **Settings>Vehicle> Collision/Detection Systems>Forward Collision System.**

OPTIONAL EQUIPMENT

PCW ENHANCED DRIVER ALERT PACKAGE

INCLUDES THE FOLLOWING ORDER CODES PLUS JD4 POWER ADJUSTABLE PEDALS

TQ5

INTELLIBEAM HEADLIGHTS

Exterior Lamp Controls here



IntelliBeam System This system turns the vehicle's high-beam headlamps on and off according to surrounding traffic conditions. The system turns the high beam headlamps on when it is dark enough and there is no other traffic present. This light comes on in the instrument cluster when the IntelliBeam system is enabled.

Turning On and Enabling IntelliBeam To enable the IntelliBeam system, with the turn signal lever in the neutral position, turn the exterior lamp control to AUTO. The blue high-beam on light appears on the instrument cluster when the high beams are on.

Driving with IntelliBeam The system only activates the high beams when driving over 40 km/h (25 mph). There is a sensor near the top center of the windshield that automatically controls the system. Keep this area of the windshield clear of debris to allow for best system performance. The high-beam headlamps remain on, under the automatic control, until one of the following situations occurs:

- The system detects an approaching vehicle's headlamps.
- The system detects a preceding vehicle's taillamps.
- The outside light is bright enough that high-beam headlamps are not required.
- The vehicle's speed drops below 20 km/h (12 mph).
- The IntelliBeam system can be disabled by the High/Low-Beam Changer or the Flash-to-Pass feature. If this happens, the High/Low-Beam Changer must be activated on then off within two seconds to reactivate the IntelliBeam system. The instrument cluster light will come on to indicate the IntelliBeam is reactivated. The high beams may not turn off automatically if the system cannot detect another vehicle's lamps because of any of the following:
 - The other vehicle's lamps are missing, damaged, obstructed from view, or otherwise undetected.
 - The other vehicle's lamps are covered with dirt, snow, and/or road spray.
 - The other vehicle's lamps cannot be detected due to dense exhaust, smoke, fog, snow, road spray, mist, or other airborne obstructions.
- The vehicle's windshield is dirty, cracked, or obstructed by something that blocks the view of the light sensor.
- The vehicle is loaded such that the front end points upward, causing the light sensor to aim high and not detect headlamps and taillamps.
- The vehicle is being driven on winding or hilly roads. The automatic high-beam headlamps may need to be disabled if any of the above conditions exist.

UHX

LANE KEEP ASSIST WITH LANE DEPARTURE WARNING AND SAFETY ALERT SEAT

Lane Keep Assist (LKA) may help avoid crashes due to unintentional lane departures. It may also provide a Lane Departure Warning (LDW) system alert as the lane marking is crossed. The LKA system will not assist or provide an LDW alert if it detects that you are actively steering. Override LKA by turning the steering wheel. LKA uses a camera to detect lane markings between 60 km/h (37 mph) and 180 km/h (112 mph).

How the System Works The LKA camera sensor is on the Windshield. To turn LKA on and off, press to the left of the steering wheel. When on, is green if LKA is available to assist and provide LDW alerts. It may assist by gently turning the steering wheel and display as amber if the vehicle approaches a detected lane marking without using a turn signal in that direction. It may also provide an LDW alert by flashing amber as the lane marking is crossed. Additionally, there may be three beeps, or the driver seat may pulse three times, on the right or left, depending on the lane departure direction.

Take Steering The LKA system does not continuously steer the vehicle. If LKA does not detect active driver steering, an alert, chime, or DIC message may be provided. Steer the vehicle to dismiss.

SAFETY ALERT SEAT

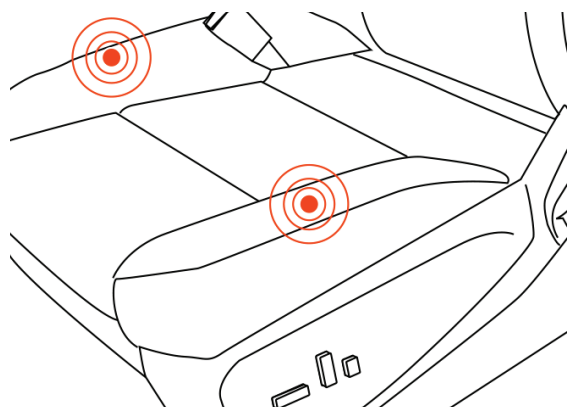

The Safety Alert Seat uses pulsing driver seat vibrations to intuitively communicate the direction of a possible crash threat.

How To Use It When the windshield mounted camera detects a possible collision, the Safety Alert Seat pulses on the left, right or both sides of the seat to alert drivers to the direction of the possible danger. When this happens, visual alerts will also notify the driver.

Just like a smartphone, drivers can select either Auditory or Vibration Alerts using the vehicle settings menu. The selected Safety Alert Seat or Auditory Alert setting applies to all crash avoidance alerts:

- The available Lane Keep Assist with Lane Departure Warning systems use left-and-right-side pulses to alert drivers if they unintentionally drift out of their lane.
- Several active safety features pulse both sides of the seat simultaneously.
- The available Forward Collision Alert system pulses on both sides to warn drivers of a possible collision with the vehicle that they're following

Note: Safety or driver assistance features are no substitute for the driver's responsibility to operate the vehicle in a safe manner. The driver should remain attentive to traffic, surroundings and road conditions at all times. Visibility, weather, and road conditions may affect feature performance. Read the vehicle's owner's manual for more important feature limitations and information.

OPTIONAL EQUIPMENT

V76

RECOVERY HOOKS

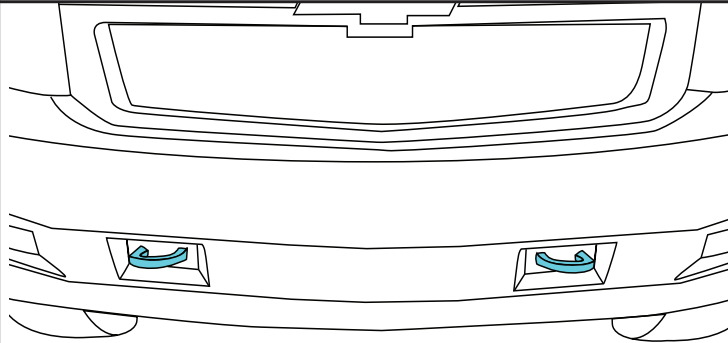

Two black front frame mounted.

NOTE: Front recovery hooks are for vehicle recovery only. To avoid the risk of injury, never use recovery hooks to tow a vehicle.

S6N

TRAILER HITCH INSERT

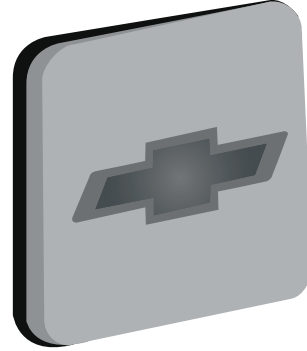

Black rubber square with a logo that closes out the receiver

VQK

SPLASH GUARDS, MOLDED

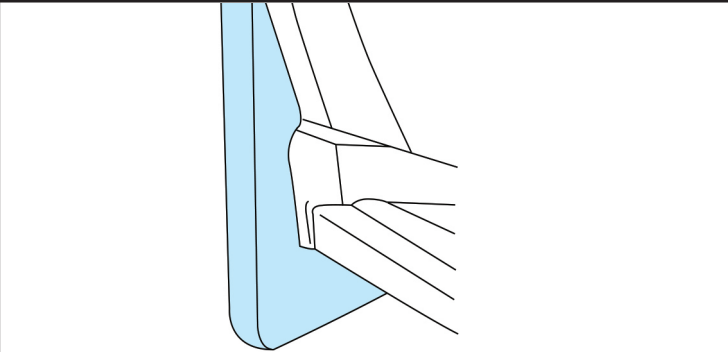

Black finish

VK3

FRONT LICENSE PLATE MOUNTING PACKAGE

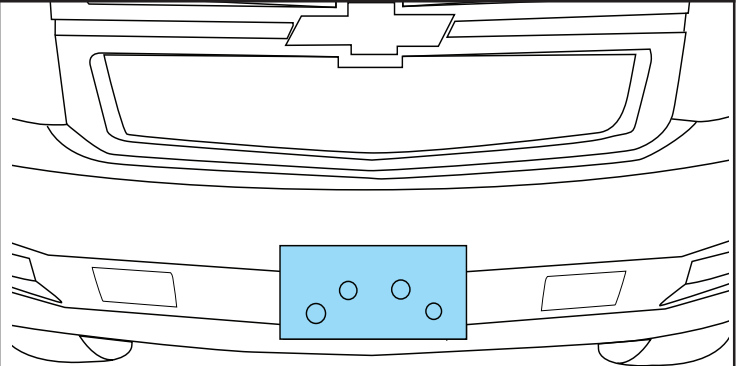

Includes, Bracket and mounting screws

UT7

GROUND STUDS

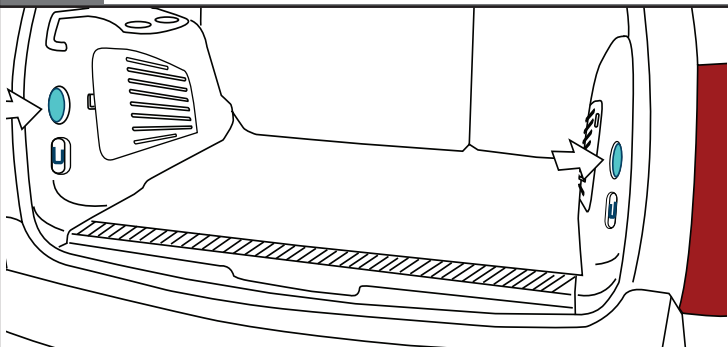

Studs are located on the left and right of the liftgate opening above the tie-down rings

UN9

RADIO SUPPRESSION GROUND STRAPS

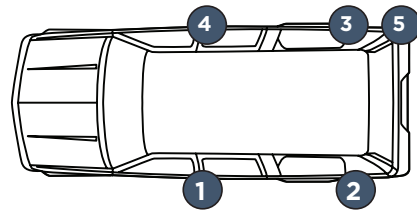

Provides additional grounding in the following locations:

1. Left hand front frame body mount bracket to underbody
2. Left hand rear frame body mount bracket to rear underbody
3. Right hand rear frame body mount bracket to rear underbody
4. Right hand front frame body mount bracket to underbody
5. Exhaust pipe hanger rod to rear frame hanger

OPTIONAL EQUIPMENT

6N5 SWITCHES - REAR WINDOW INOPERATIVE

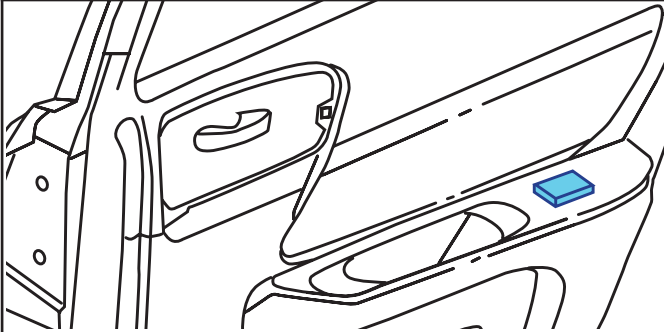

Rear door window switches are inoperable. Rear door power regulators are operable only from driver position switches.

6N6 REAR DOOR LOCKS AND HANDLES INOPERATIVE

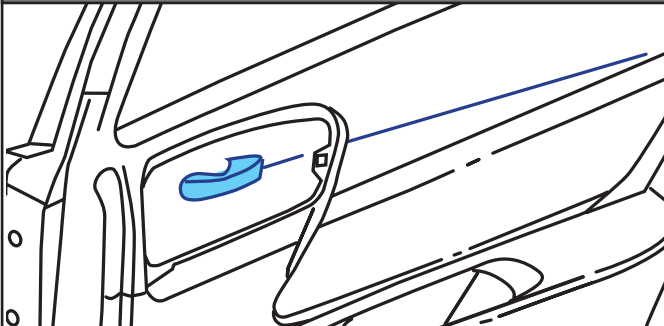

Rear door locking rods are disabled. Rear door locks are inoperable at rear doors, but operate from driver position. Inside rear door handles are disconnected. Rear doors can only be opened from the outside.

6C7 AUXILIARY DOME LAMP

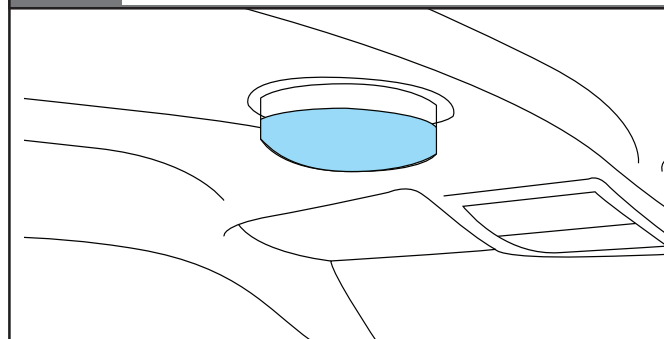

Auxiliary dome lamp is located on the headliner to the rear of the overhead console and is switched at the rear lamp base. Lamp is wired separately standard dome lamps with red and white LED bulbs.

6J7 EXTERIOR LAMPS EMERGENCY FLASHING SYSTEM

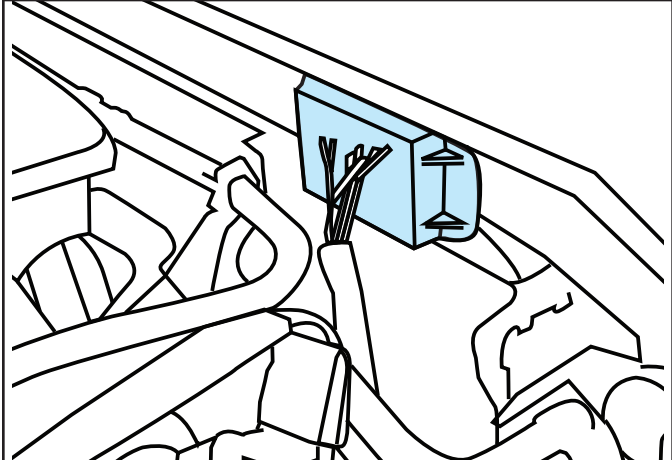

Option 6J7 provides a headlamps high beam flashing module, rear lamps flashing via the Body Control Module (BCM) and a control wire for customer-furnished switching to turn the module on and off. The flasher control wire is part of the blunt-cut upfitter harness coiled under the instrument panel in the front passenger side foot well. The flashing module is located on the rear edge of the right hand upper radiator support.

The headlamp flashing module is activated by the application of 12 volts to a dark green wire in the upfitter harness connector labeled 6J3. When activated, the headlamp high beams and the high beam instrument cluster indicator will flash alternately at 3.0 flashes per second. When the flashing module is turned on, the module sends a signal to the BCM which alternately flashes the stop lamps and backup lamps at the same flash rate as the headlamps. Depressing the brake pedal will override the stop lamp flashing and placing the transmission in Reverse will override the backup lamps flashing.

During daylight conditions, the Daytime Running Lamps (DRL) are automatically turned off whenever the headlamps flashing module is activated. During night time conditions, the low beam headlamps automatically turn on while the high beam lamps flash. Turning on the high beam headlamps manually will override the flashing module and the high beam headlamps will operate continuously. During night time conditions the tail lamps will turn on automatically. If Option 9G8 is present the low beam headlamps and tail lamps will not come on automatically. The Center Mounted Stop Lamp will operate only when the service brakes are applied.

A 10-amp fuse labeled POLICE UPFITTER protects the flasher module circuit. The fuse is located in the Underhood Electrical Center in the engine compartment on the driver side of the vehicle. See also the Owner Manual for more information.

Activation of the headlamps flashing and rear lamps flashing can be separated by opening the blue/green BCM circuit at the flasher module connector, X122-F, and applying a customer-switched ground to the blue/green wire in the upfitter harness which is located under the center instrument panel. Power to the green flasher module activation wire must be off for the rear lamps flashing only.

Warning:
BCM will be damaged if 12V power is connected to the dark-blue/yellow wire.

NOTES:

- Wiring connection or splice changes are to be removed before the vehicle is returned to civilian use.
- For wiring diagram see Wiring Section

OPTIONAL EQUIPMENT

6J3 WIRING PROVISIONS FOR VEHICLE GRILLE LAMPS AND SPEAKER/SIREN

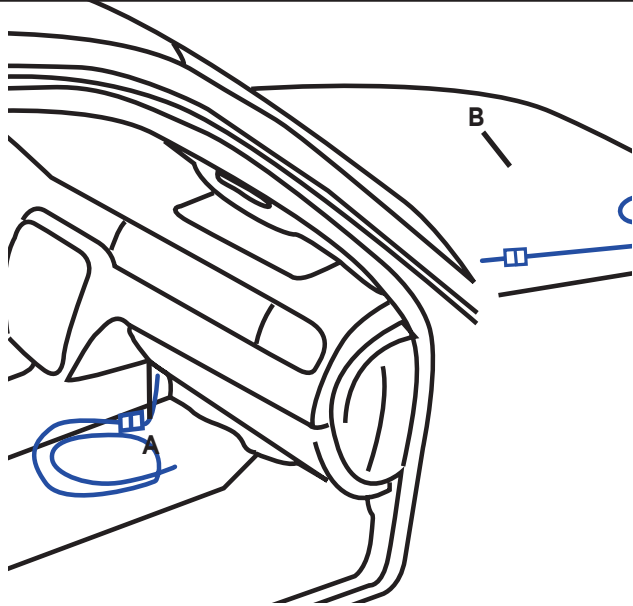

- A. Blunt cut ends for the customer-furnished grille lamps and customer-furnished siren/speaker
- B. Control wires from in-line connector in forward lamp harness for customer-furnished grille lamps and speaker

The SEO 6J3 wiring provision has a 5-foot (1.5 m) harness coiled underneath the instrument panel on the passenger side. The wiring circuits are routed from under the instrument panel to a 1-foot (30 cm) coil secured in the area behind the grille. There are four 16-gauge (1.0 mm²) wires for connecting to the grille lamps (GRY, TAN) and siren speaker (LT BU, LT GN)

The SEO 6J3 wiring provision also includes one 18-gauge (0.8 mm²) control wire for the SEO 6J7 Exterior Lamps Emergency Flashing System.

When Option 6J7 is installed without Option 6J3, only the blunt-cut green control wire is provided under the center instrument panel for activating the Emergency Flashing System. The blunt-cut blue/green Separation-of-Function wire for customer switching to activate only rear lamps flashing is located in the upfitter branch harness exiting below the center instrument panel. For only rear lamps flashing, power to the green module activation wire must be off.

NOTES:

- Wiring connection or splice changes are to be removed before the vehicle is returned to civilian use.
- For wiring diagram see Wiring Section

WX7 WIRING PROVISION FOR FRONT SPEAKERS

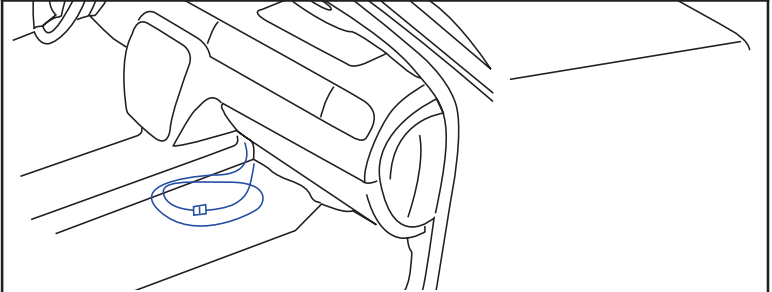

Approximately 60 inches (1.5 m) of auxiliary speaker wiring is routed from the front door and windshield pillar speakers and coiled under the instrument panel. The wiring permits connection of the front speaker pairs to customer-installed communication equipment. Vehicle radio front speaker outputs are re-routed to the rear speakers to maintain the required open door/key-in-ignition and other audible warnings.

NOTES:

- Wiring connection or splice changes are to be removed before the vehicle is returned to civilian use.
- For wiring diagram see Wiring Section

6J4 WIRING PROVISION FOR HORN SIREN CIRCUIT

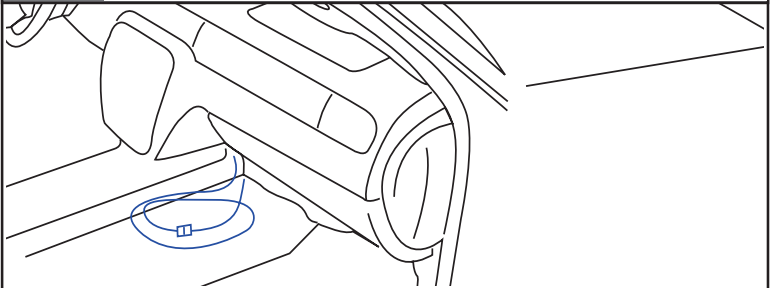

This provision permits customer connection of a switch to select either horn of siren operation when the horn pad is pressed.

A 22-gauge (0.35 mm²) wire is connected to an in-line connector in the horn circuit of the instrument panel harness under the instrument panel. The end of this harness extension is a 5-foot (1.5 m) loop of wire coiled under the center of the instrument panel.

NOTES:

- Wiring connection or splice changes are to be removed before the vehicle is returned to civilian use.
- For wiring diagram see Wiring Section

OPTIONAL EQUIPMENT

7X6

SPOTLAMPS

7X7

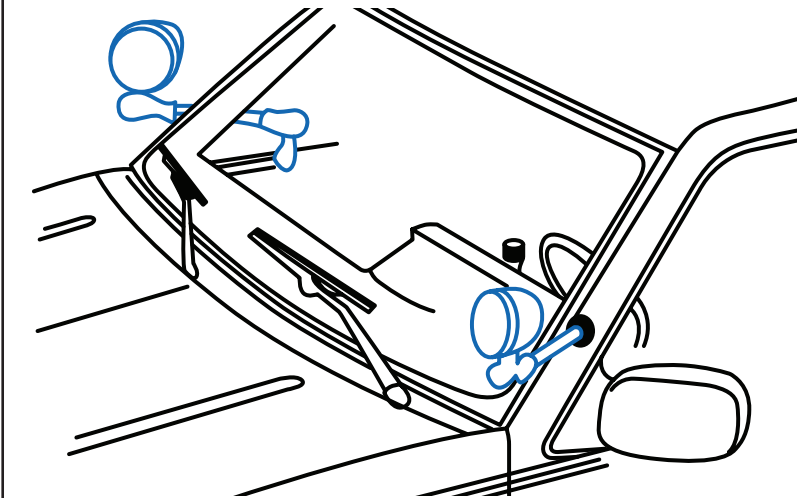

- 7X6 Spotlamp left hand, pillar-mounted unity, 6-inch with replaceable H3 halogen bulb; independently fused
- 7X7 Spotlamps left and right hand, pillar-mounted unity, 6-inch with replaceable H3 halogen bulb; independently fused

NOTE

- Lamp bulbs are halogen 12 volt 100 watt H-3 rated at 245,000 candle power
- For fuse location see Wiring Section
- Factory installation of spotlamps is recommended. Special tooling is used to locate and drill the spotlamp shaft hole in the windshield pillars. Field installation of spotlamps must not interfere with proper deployment of the roof rail mounted head-curtain airbags in the event of a crash.
- A customer furnished spotlamp assembly must be installed to avoid interference with proper deployment of roof rail mounted head-curtain and instrument panel passenger side airbags

5HP

PACKAGE OF SIX ADDITIONAL KEYS

PROGRAMMING KEYS WITHOUT TRANSMITTERS

A maximum of eight random code ignition keys can be programmed for a Tahoe Police (PPV) or Special Service Vehicle (SSV). An unlimited number of ignition keys can be learned if the vehicle is equipped with either fleet Common Code Option 6E2 or Option 6E8. (This procedure can also be used to program new ignition keys for Model Year 2017 Tahoe PPV and SSV vehicles.) Two original ignition keys are required for this procedure.

Note: If only one previously ignition key is available, the programming of new keys must be performed by a dealer using the Service Programming System (SPS). Ignition key programming is not a warranty item and programming is conducted by the customer or at a dealer at customer expense.

ADDING KEYS PROGRAMMING PROCEDURE

1. Insert the first of two (2) original ignition keys in the ignition switch and turn the key to ON/RUN without starting engine.
2. Turn the key to LOCK/OFF and remove the key.
3. Within five (5) seconds, insert the second original ignition key and turn it to ON/RUN without starting engine.
4. Turn the key to LOCK/OFF and remove the key.
5. Within five (5) seconds, insert the new key to be programmed and turn it to ON/RUN without starting engine. The Theft Security Light will turn OFF once the new has been learned.
6. Remove the newly programmed key and repeat steps 1-5 for all additional new keys.
7. Verify the newly programmed keys will start the vehicle engine.

AMF

PACKAGE OF SIX UNPROGRAMMED TRANSMITTERS

PROGRAMMING KEYED ENTRY TRANSMITTERS (RKE)

A maximum of eight transmitters can be programmed for a Tahoe Police (PPV) or Special Service Vehicle (SSV). The programming procedure for SEO AMF transmitters requires that both previously learned transmitters must be present in the vehicle. (This procedure can also be used to program new transmitters for Model Year 2017 Tahoe PPV and SSV vehicles.) Two original ignition keys are required for this procedure.

NOTE: If only one previously learned transmitter is available, the programming of the new transmitters must be performed by a dealer using the Service Programming System (SPS). Transmitter programming is not a warranty item and programming is conducted by the customer or at a dealer at customer expense.

Vehicles ordered with (BTV) remote start will include transmitters with remote start button.

PROGRAMMING PROCEDURE:

1. Using the ignition key, turn the ignition ON but do not crank the engine. The transmission selector must be in PARK.
2. Using the SELECT and other buttons on the right side of the steering wheel, open the Driver Information Center (DIC) Main Menu. Scroll down to Main Menu item OPTIONS with the lower steering wheel button and then SELECT. Scroll to REMOTE KEY RELEARN and Select START. The DIC will display LEARNING ACTIVE.
3. At the same time, press and hold LOCK and UNLOCK on the RKE transmitter for approximately 5 seconds. A beep will sound, indicating the transmitter is matched to the vehicle.
4. Repeat Step 3 to match up the next RKE transmitter.
5. To exit the RKE programming mode, turn the ignition key to LOCK/OFF.
6. Verify that all transmitters are learned by operating the door locks remotely.

WIRING

WIRING DIAGRAM FOR 12-VOLT BATTERY POWER SUPPLY

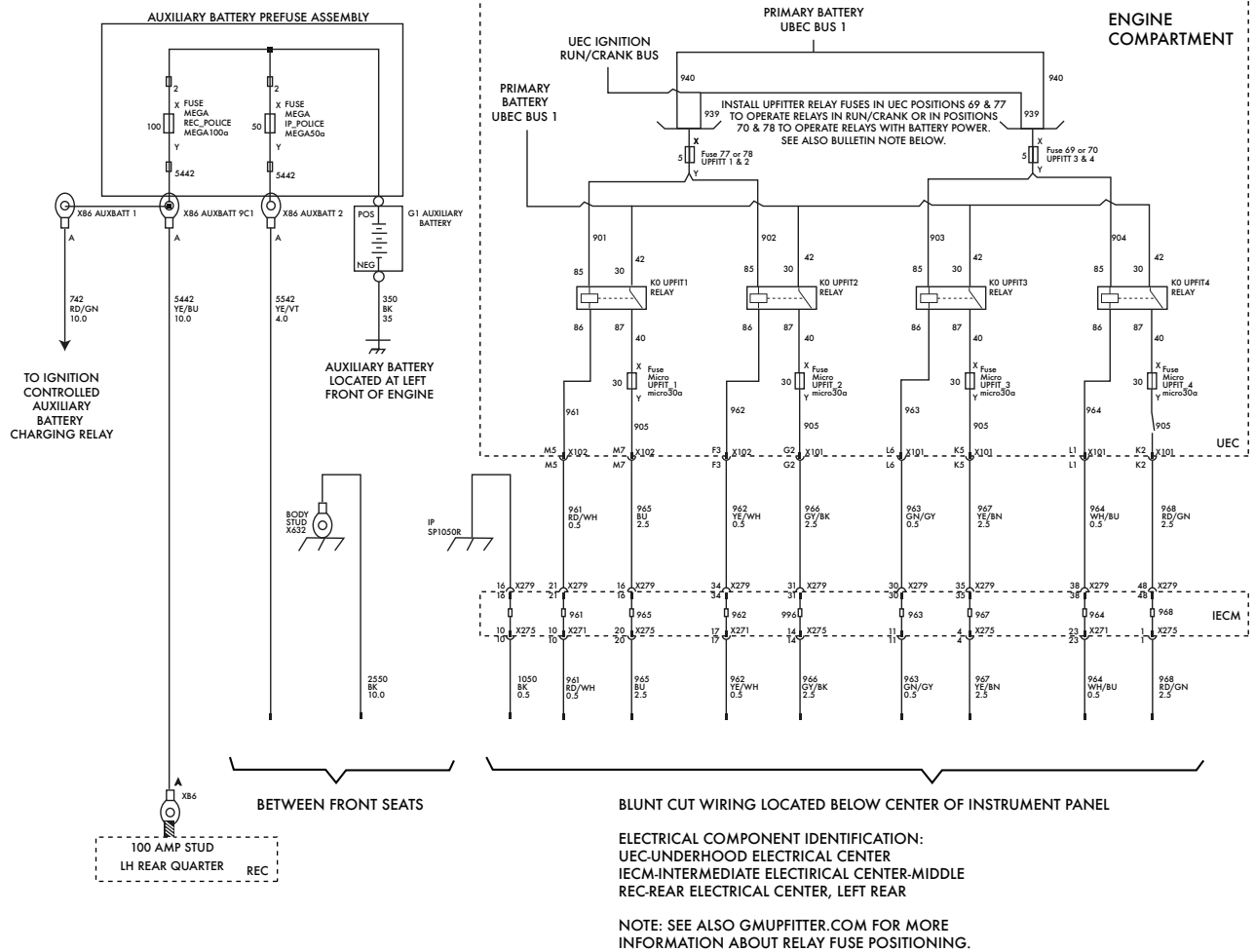

NOTE: Wiring connection or splice changes are to be removed before the vehicle is returned to civilian use.

NOTE: Wiring diagrams for these options are shown in the Police Package owner's manual supplement (shipped in glove box).

WIRING

WIRING PROVISIONS IGNITION POWER AND SIGNAL CIRCUITS

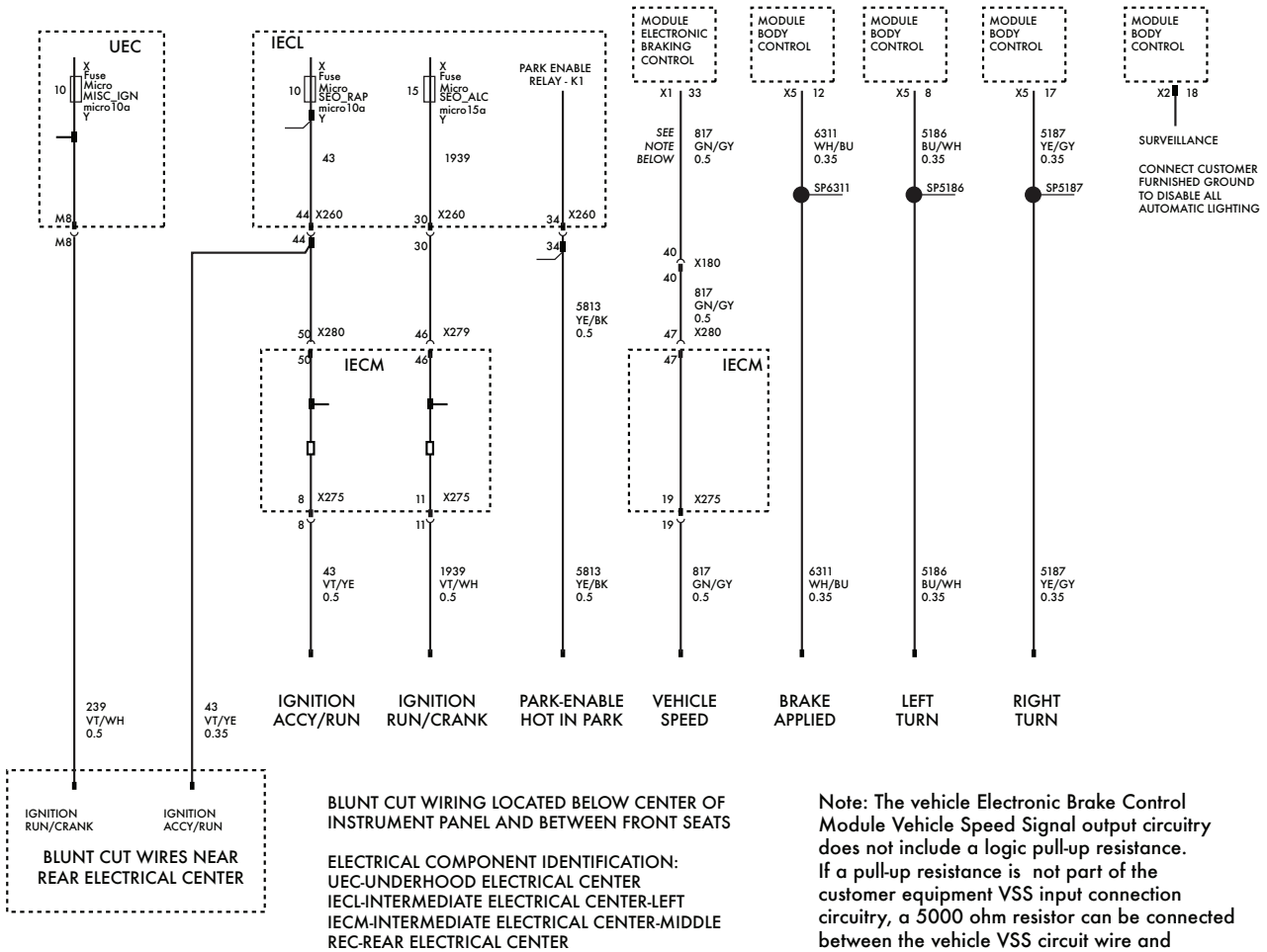

NOTE: Wiring connection or splice changes are to be removed before the vehicle is returned to civilian use.

NOTE: Wiring diagrams for these options are shown in the Police Package owner's manual supplement (shipped in glove box).

WIRING

WIRING PROVISION FOR OPTION 6J3 VEHICLE GRILLE LAMPS AND SPEAKER/SIREN

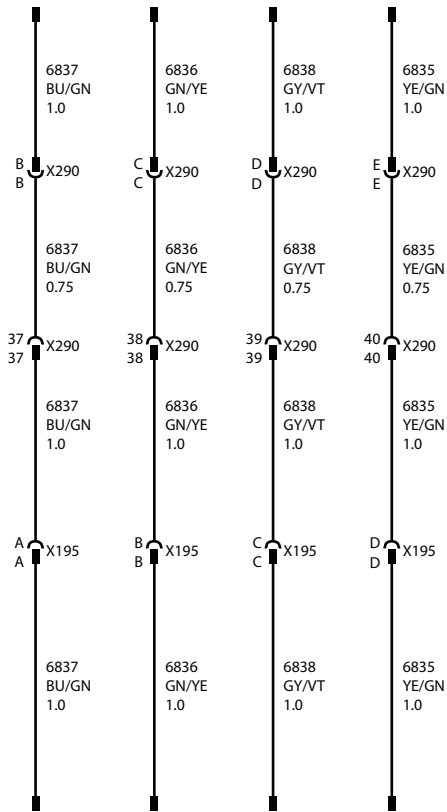

PACKAGED UNDERHOOD BY RIGHT REAR BATTERY

WIRES FOR SIREN

WIRES FOR GRILL LAMPS

NOTE: Wiring connection or splice changes are to be removed before the vehicle is returned to civilian use.

WINDSHIELD PILLAR-MOUNTED SPOTLAMPS OPTION 7X6 LH ONLY / OPTION 7X7 LH AND RH

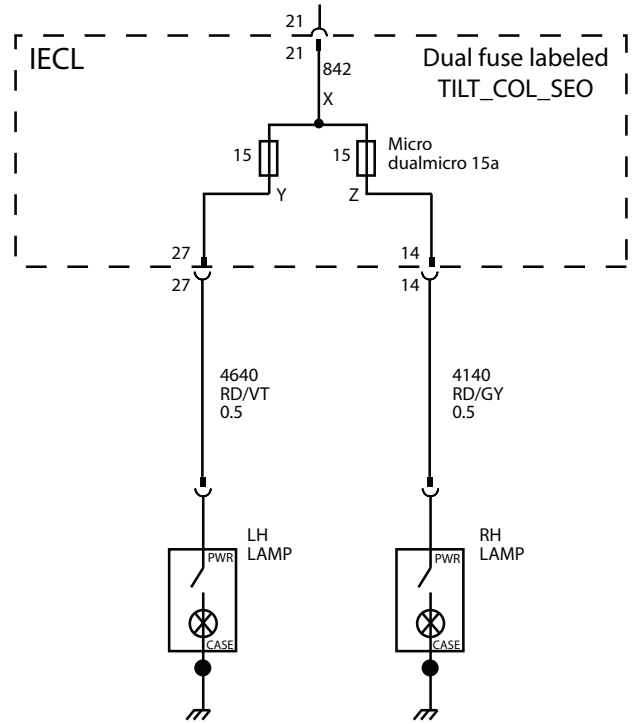

IECL - INTERMEDIATE ELECTRICAL CENTER-LEFT

LAMP BULBS - HALOGEN H7635

NOTE: Wiring diagrams for these options are shown in the Police Package owner's manual supplement (shipped in glove box).

WIRING

WIRING PROVISION FOR OPTION 6J7 EXTERIOR LAMPS EMERGENCY FLASHING SYSTEM

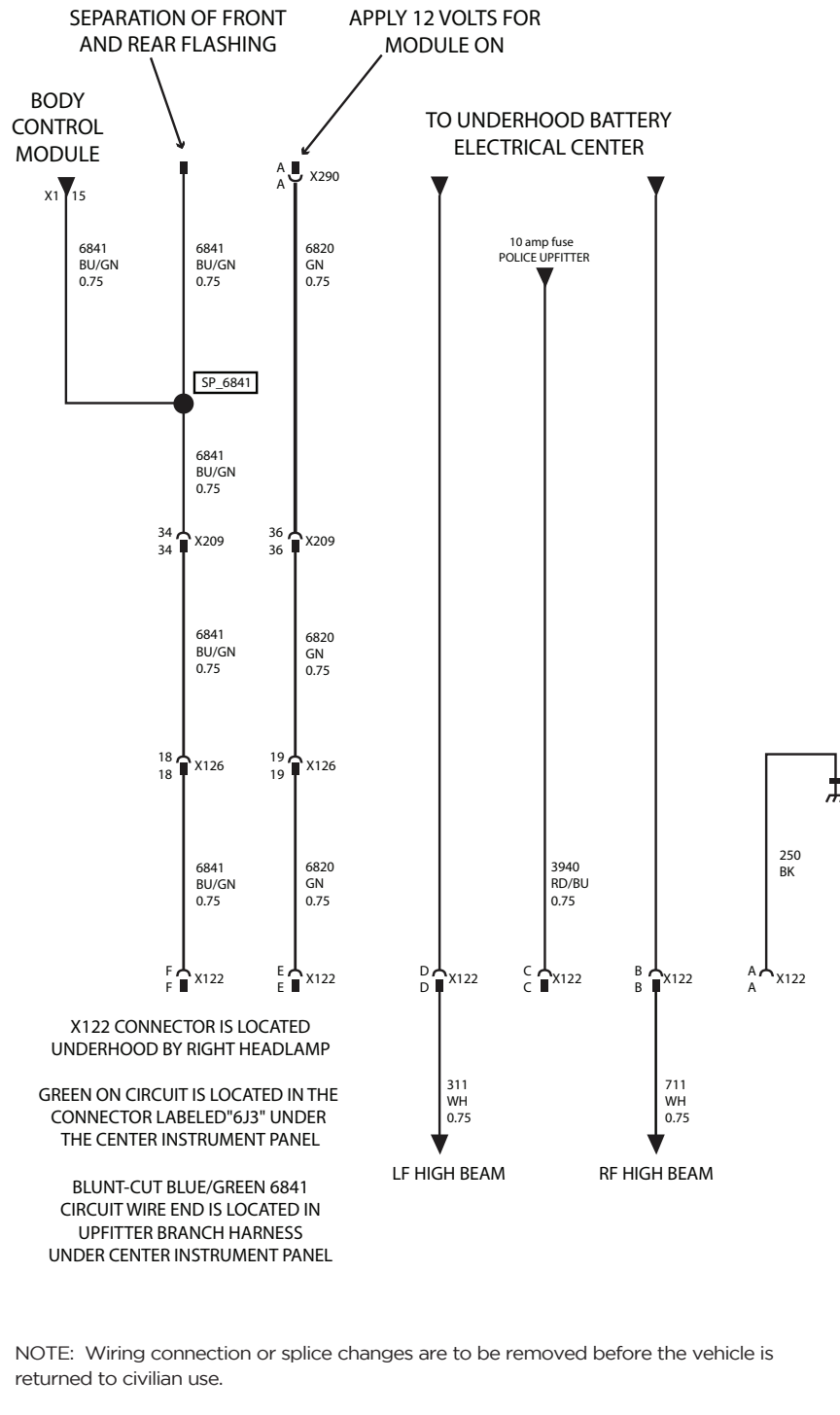

NOTE: Wiring diagrams for these options are shown in the Police Package owner's manual supplement (shipped in glove box).

WIRING

WIRING PROVISION FOR OPTION 6J4, HORN - SIREN CIRCUIT

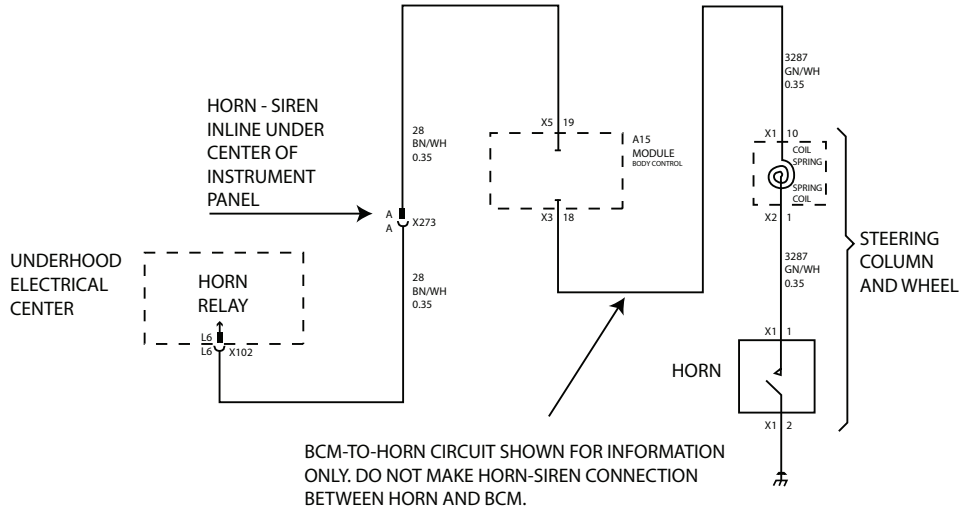

NOTE: Wiring connection or splice changes are to be removed before the vehicle is returned to civilian use.

WIRING DIAGRAM FOR OPTION WX7 IN-LINE CONNECTOR

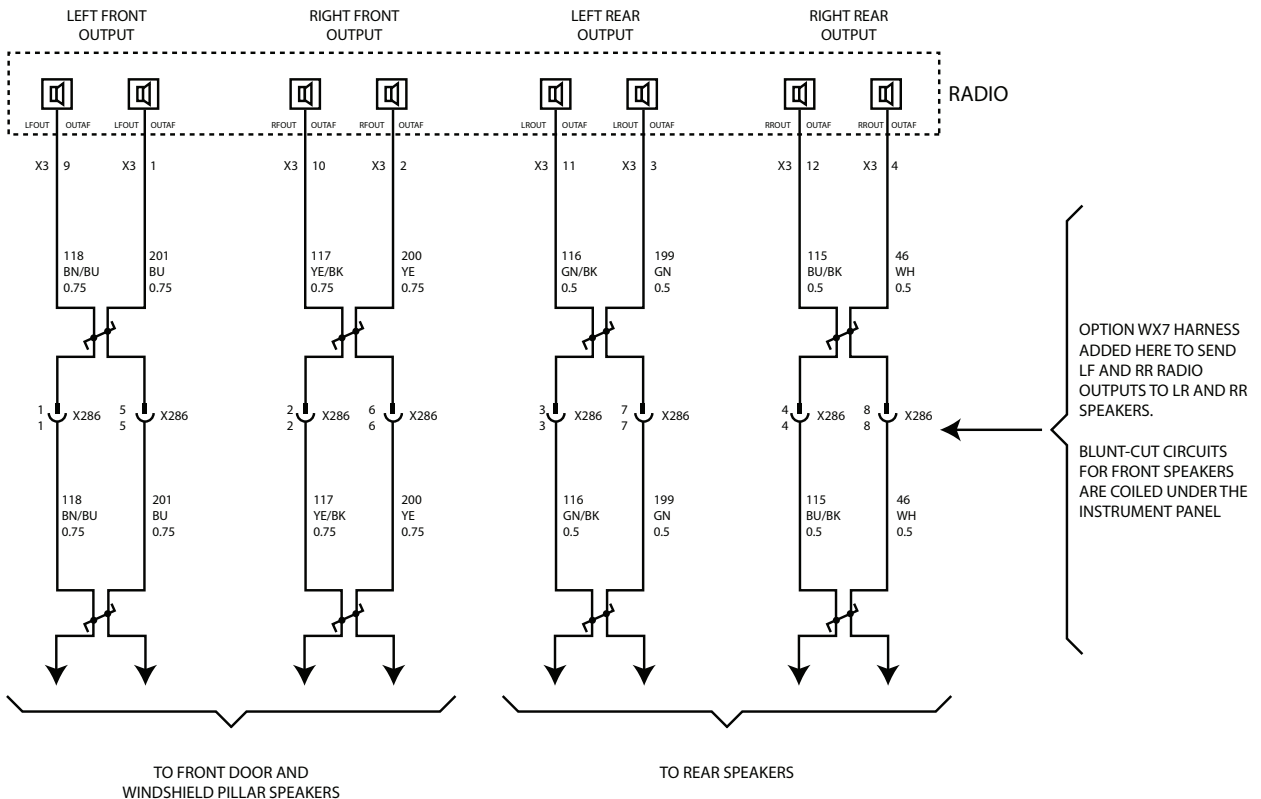

NOTE: Wiring connection or splice changes are to be removed before the vehicle is returned to civilian use.

NOTE: Wiring diagrams for these options are shown in the Police Package owner's manual supplement (shipped in glove box).

AIRBAGS

TOP VIEW OF INSTRUMENT PANEL AND APPROXIMATE DEPLOYMENT AREA OF THE AIRBAG ZONE

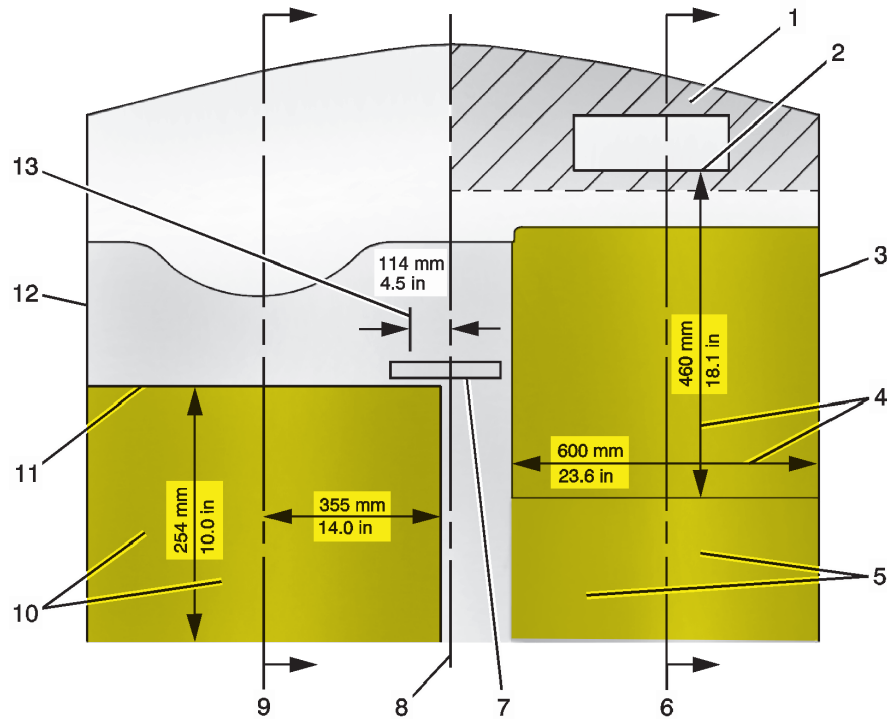

1. Passenger Side Instrument Panel Top Surface Zone
2. Frontal Outboard Passenger Airbag Module Trim Panel - Rear Edge
3. Passenger Side Door
4. Approximate Dimensions of Inflated Airbag
5. Frontal Outboard Passenger Airbag Deployment Zone
6. Passenger Centerline
7. Inside Rearview Mirror
8. Vehicle Centerline
9. Driver Centerline
10. Driver Frontal Airbag Deployment Zone
11. Front of Steering Wheel
12. Driver Side Door
13. Shift Selector Arc

Sitting too close to an airbag when it deploys can increase the risk of serious injury or death. Always properly wear your seat belt. See Owner's Manual for more information.

AIRBAGS

SIDE VIEW OF DRIVER FRONTAL AIRBAG DEPLOYMENT ZONE

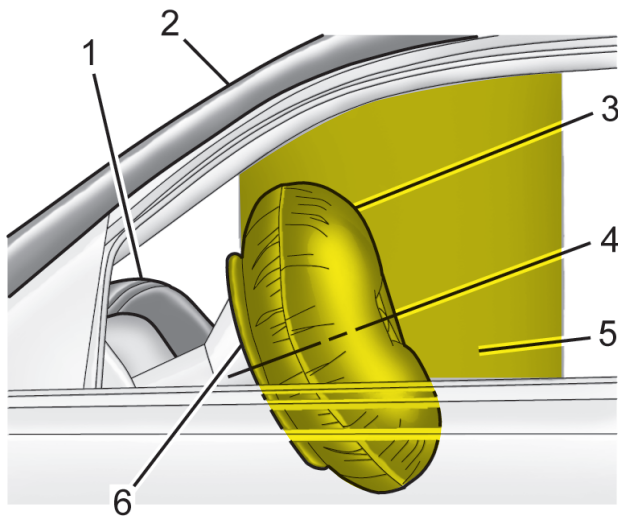

1. Top of Instrument Panel
2. Top Edge of Windshield
3. Inflated Airbag - Steering Wheel
4. Centerline of Steering Column at Mid-Tilt
5. Driver Frontal Airbag Deployment Zone
6. Front of Steering Wheel

SIDE VIEW OF FRONTAL OUTBOARD PASSENGER AIRBAG DEPLOYMENT ZONE

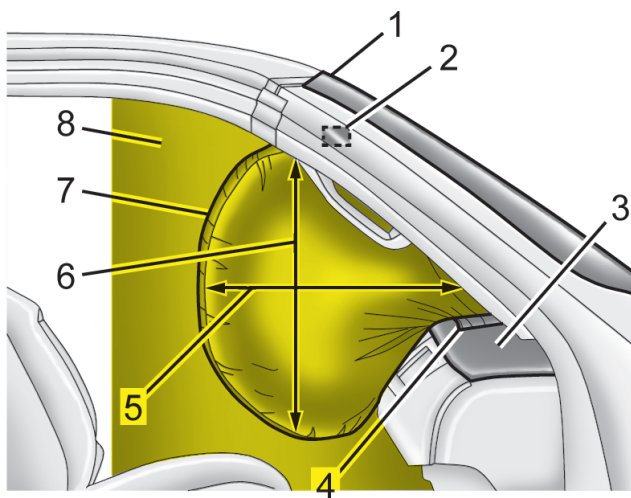

1. Top Edge of Windshield
2. Inside Rearview Mirror
3. Instrument Panel Top Surface Zone
4. Frontal Outboard Passenger Airbag Module Trim Panel - Rear Edge
5. Inflated Airbag - Horizontal Dimension, approximately 18.1 in (460 mm)
6. Inflated Airbag - Vertical Dimension (from Top of Occupant's Lap to Headliner)
7. Inflated Airbag - Instrument Panel
8. Frontal Outboard Passenger Airbag Deployment Zone

Sitting too close to an airbag when it deploys can increase the risk of serious injury or death. Always properly wear your seat belt. See Owner's Manual for more information.

AIRBAGS

ROOF-RAIL MOUNTED HEAD-CURTAIN AIRBAG DEPLOYMENT ZONES - PASSENGER SIDE SHOWN, DRIVER SIDE SIMILAR

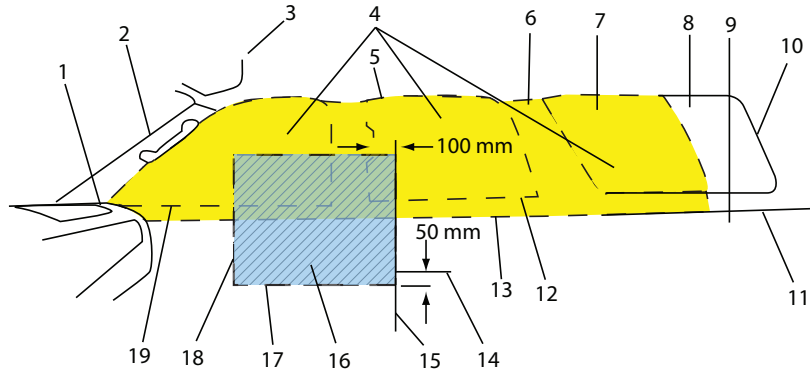

- | | |
|---|---|
| <ol style="list-style-type: none"> 1. Front of Deployment Zone at Bottom of Windshield Pillar Trim 2. A-Pillar Trim with Grab Handle (Passenger Side) 3. Sun Visor 4. Deployment Zone - Seat Rows 1 and 2 and Cargo Area 5. Top of Deployment Zone - Along Roof-rail at Edge of Headliner 6. C-Pillar Upper Trim 7. Rear Quarter Window 8. D-Pillar Upper Trim 9. Rear of Cargo Area Zone at Back Corner of Headliner 10. Rear of Vehicle at liftgate Opening 11. Bottom of Cargo Area Zone at Rear Side Trim Cupholders 12. Top Edge of Rear Door Trim | <ol style="list-style-type: none"> 13. Bottom of Deployment Zone at Top of Side Door Armrests 14. Top Surface of Front Seat Cushion (with Seal Fully lowered) 15. Seat-Mounted Side Impact Airbag Deployment Zone (3.9 in (100 mm)) to Rearward of Back Edge of B-Pillar Trim Grab Handle) 16. Front Seat Deployment Zone (With Seat Fully Lowered) 17. Bottom of Seat-Mounted Side Impact Airbag Zone (2.0 in (50 mm)) Below Top of Seat Cushion with Seat Fully lowered 18. Rear of Front Door Trim Armrest Handle 19. Top Edge of Front Door Trim |
|---|---|

The roof-rail mounted head-curtain airbag deploys in the cargo area. Third-row seating is not available on the police package (RPO 9C) or the special service package (RPO 5W4).

ROOF RAIL MOUNTED HEAD CURTAIN AIRBAG DRIVER AND OUTBOARD FRONT PASSENGER DEPLOYMENT ZONES - VIEW FROM REAR CARGO AREA

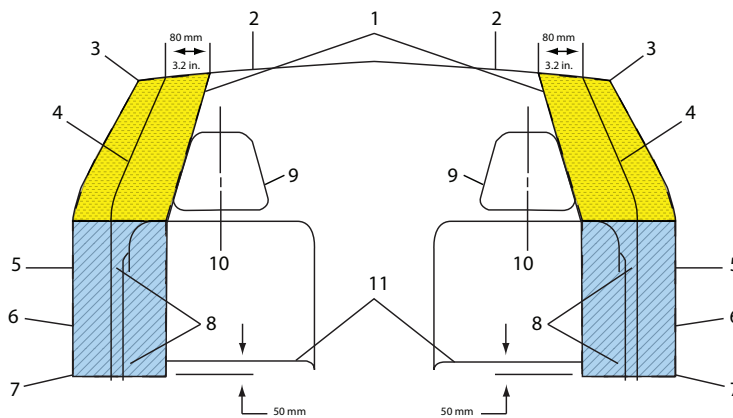

- | | |
|---|---|
| <ol style="list-style-type: none"> 1. Roof-Rail Mounted Head-Curtain Airbag Deployment Zone 2. Underside of Headliner 3. Edge of Headliner 4. Inner Center and Rear Pillar Trim 5. Inner Front and Rear Door 6. Side Door Upper Armrests and Rear Quarter Trim Armrests | <ol style="list-style-type: none"> 7. Seat-Mounted Side Impact Airbag Deployment Zone (2.0 in (50 mm)) Below Top Surface of Outboard Front Seat Cushion with Seat Fully Lowered. 8. Front Seatback Side Deployment Zone 9. Front Seat Head Restraint 10. Seat Centerline 11. Top of Seat Cushion |
|---|---|

Sitting too close to an airbag when it deploys can increase the risk of serious injury or death. Always properly wear your seat belt. See Owner's Manual for more information.

AIRBAGS

OPTIONAL INBOARD DRIVER SEATBACK FRONT CENTER AIRBAG (RPO AYQ AND D07) INCLUDED WITH A95 BUCKET SEATS - VIEW FROM PASSENGER SIDE

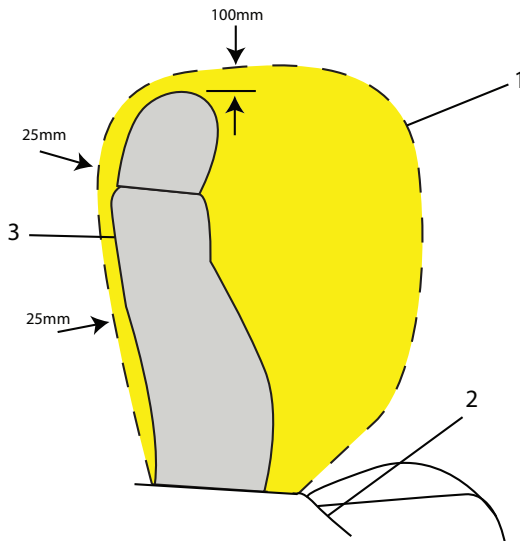

1. Inboard Driver Seatback Front Center Airbag
2. Front Center Console
3. Driver Seat and Head Restraint

Deployment zones for the Driver Inboard Seatback-mounted Front Center Airbag, Driver Outboard and Front Outboard Seatback-mounted Side Impact Airbags move up, down, fore, and aft as the seat is adjusted by the occupant.

The Inboard Driver Seatback Front center airbag (RPO AYQ) requires front bucket seats (RPO A95) and the front center console (RPO D07).

Do not remove the front center console to install customer equipment or install customer equipment between the front bucket seats. The equipment may interfere with the deployment of the Inboard Driver Seatback Front center airbag.

OPTIONAL INBOARD DRIVER SEATBACK FRONT CENTER AIRBAG DEPLOYMENT ZONE (RPO AYQ AND D07) - VIEW FROM REAR CARGO AREA

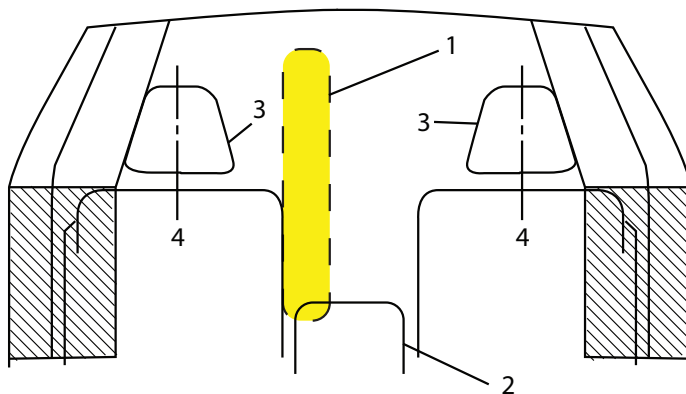

1. Driver Inboard Seatback Front Center Airbag (RPO AYQ)
2. Front Center Console (RPO D07)
3. Front Seat Head Restraint
4. Seat Centerline

Sitting too close to an airbag when it deploys can increase the risk of serious injury or death. Always properly wear your seat belt. See Owner's Manual for more information.

AIRBAGS FAQ

Q: Can equipment such as radar devices, video cameras, and radio trees be mounted in a specialty vehicle equipped with a right front passenger frontal airbag?

A: Yes, but care must be taken to properly mount the equipment outside of the airbag "deployment zone."

Q: What is the airbag "deployment zone"?

A: The term "deployment zone" describes the space an airbag takes up when fully inflated. Airbags need room to work properly, and anything in the "deployment zone" - such as improperly mounted equipment - can greatly affect the performance of the airbag.

Q: How can I identify the airbag "deployment zone" in my vehicle?

A: See Airbag Deployment Diagrams for more information. The diagrams provide the approximate dimensions of the "deployment zones" for your specialty vehicle. Before doing any service work, including the installation of any equipment, consult the appropriate service manual.

Q: Is it possible to shield equipment so it does not interfere with airbag deployment?

A: While shielding may protect certain equipment from being damaged or dislodged, it may also negatively affect how an airbag inflates. Therefore, we cannot recommend the placement of any equipment in the deployment zone, even when shielding.

Q: Can the installation of push bumpers on the front end of the vehicle affect the deployment of the airbag?

A: It is not likely that installing push bumpers will affect sensing for the airbag as long as the vehicle structure itself is not modified. GM is not aware of any adverse defects from the many push bumpers that have been installed on current model GM police vehicles with airbags.

See "Adding Equipment to the Airbag-Equipped Vehicle" in the owner manual for more information.

Customer-Installed Equipment

Before installing equipment, read the following.

Airbags inflate with great force, faster than the blink of an eye. No objects, such as shotguns, should be placed over or near the airbag covers. Equipment mounted too close to an inflating airbag could prevent the airbag from operating properly to protect the occupants or could be forced into an occupant or break and become a dangerous projectile, causing severe injury or even death. To help prevent injury and to allow the airbag to perform as it was designed, do not mount equipment inside the airbag deployment zones.

Do not install equipment in the inflation path of any airbag. The equipment may interfere with the deployment of the airbag, may damage the airbag, or otherwise be damaged or forced into an occupant, all of which may cause severe injury or even death.

Do not attach anything to the steering wheel hub or mount any equipment within the deployment zone for the driver airbag.

Do not mount equipment on the passenger side of the instrument panel top pad deployment zone. Equipment should not be mounted on or around the passenger airbag opening because of a deploying airbag. To allow the airbag to perform as it was designed, do not mount equipment inside the airbag deployment zone.

Do not use seat accessories that block the inflation path of the driver or passenger seat-mounted side impact airbag or install equipment in the seat-mounted side impact airbag deployment zones.

Do not mount a security barrier such that the ends of the barrier or brackets are within the roof-rail airbag deployment zones.

Avoid installing wiring for roof-rail emergency lighting or radio antennas that may restrict the proper deployment of the roof-rail airbags.

Do not use seat accessories, console accessories, or other accessories that block the inflation path of the driver seat front center airbag (if equipped). Do not remove the front center console to install a police package center console, or otherwise install equipment or mount equipment between or just behind the front bucket seats on vehicles equipped with the driver seat front center airbag.

GM approved service procedures must be followed to remove and reinstall the instrument panel to the pad to ensure proper airbag deployment.

The police vehicle has a rollover sensor mounted on the centerline of the vehicle between the driver and front outboard passenger positions. If the vehicle has individual front seats, the rollover sensor will be exposed. Do not mount equipment within 25 mm (1 in) of the rollover sensor. This may affect the performance of multiple restraint systems.

Sitting too close to an airbag when it deploys can increase the risk of serious injury or death. Always properly wear your seat belt. See Owner's Manual for more information.

ELECTRONIC STABILITY CONTROL SYSTEMS (STABILITRAK)

StabiliTrak systems help drivers maintain control of their vehicles, especially during emergency lane changes or avoidance maneuvers. StabiliTrak uses various sensors, such as steering wheel angle, wheel speed, yaw velocity, etc., to detect any difference between the path requested by the steering wheel position and vehicle's actual path. When appropriate, the system selectively controls brakes, engine power, and even suspension settings to enhance control of the vehicle's direction and help keep it on course.

Independent studies conducted by the National Highway Traffic Safety Administration, the Insurance Institute for Highway Safety, and others have found StabiliTrak to be highly reactive in reducing vehicle crashes. General Motors offers StabiliTrak systems on many of its passenger car and light truck models.

See your owner's manual for additional information about the operation of StabiliTrak.

Q. How do I use StabiliTrak?

A. StabiliTrak operates independently of the driver.

You should continue to drive your StabiliTrak equipped vehicle with caution and care. GM's StabiliTrak system, StabiliTrak is designed to be as seamless as possible in operation, and part of the overall vehicle response to make a good vehicle better in operation and part of the overall vehicle response.

Q. How does StabiliTrak work?

A. StabiliTrak has the ability to apply control forces to the vehicle independent of the driver. StabiliTrak uses sensors to continuously compare the path indicated by the steering wheel position to the vehicle's actual path. If a discrepancy is detected, StabiliTrak selectively controls vehicle brakes and engine torque to create a yaw moment that helps restore the vehicle's actual path to the path indicated by the steering wheel position. StabiliTrak has the ability to help correct both understeer (where the vehicle is not turning as much as the steering wheel position indicates) and oversteer (where the vehicle is turning more than the steering wheel position indicates).

Q. Will a tire change affect StabiliTrak?

A. Use of tires other than original equipment may affect StabiliTrak performance. StabiliTrak is designed to make the best use of available traction. The performance characteristics of the original equipment tires are part of the overall system effectiveness. When you replace tires check the recommendations in your owner's manual. On GM vehicles, the original equipment tires have a "TPC" (Tire Performance Criteria) code on the sidewall. Replacing the tires with the same "TPC" code will help assure proper StabiliTrak performance.

DRIVER OPERATED TRACTION CONTROL BUTTON

An advanced computer controlled stability enhancement system assists the driver with directional control of the vehicle in difficult driving conditions. Each time the vehicle is started, the StabiliTrak system is fully on. StabiliTrak can be controlled by a Traction Control Button. The condition system is displayed by a StabiliTrak indicator light and Driver Information

Center (DIC) Message. Push once to disable Traction Control. Push and hold to disable both Traction Control and StabiliTrak. In this condition, StabiliTrak will automatically turn ON when the vehicle speed exceeds 35 mph (56km/hr) while the Traction Control remains OFF. Push again to enable Traction Control and StabiliTrak.

MAINTENANCE / LIMITED WARRANTY

INCLUDED MAINTENANCE	One visit within first year of vehicle delivery ¹
BUMPER-TO-BUMPER LIMITED WARRANTY	3 years,/36,000 miles ² . Bumper-to-Bumper Limited Warranty with no deductible
TRANSFERABLE POWERTRAIN LIMITED WARRANTY	Qualified Fleet Customers: 5 years/100,000 miles ³
TIRES ⁴	3 years/36,000 miles ² ; coverage prorated after first 12,000 miles
ROADSIDE ASSISTANCE AND COURTESY TRANSPORTATION ⁵	Qualified Fleet Customers: 5 years/100,000 miles ³
RUST-THROUGH	6 years/100,000 miles ²
CORROSION	3 years/36,000 miles ²
WHEEL ALIGNMENT AND BALANCE	Up to 7,500 miles ⁶

1. Includes first required maintenance visit as stated in vehicle maintenance schedule. Maintenance visit consists of oil change, tire rotation and Multi-Point Vehicle Inspection. Does not include air filters. See participating dealer for other restrictions and complete details. Excludes vehicles ordered with fleet delete option RY9.
2. Whichever comes first. See dealer for limited warranty details.
3. Whichever comes first. A Qualified Fleet User is defined as a company that has purchased and registered or leased five (5) or more new cars/or trucks solely for use in its operation during the current or preceding calendar year, model year, preceding twelve (12) month period, or that owns or leases fifteen (15) or more cars and trucks. Excludes rental customers. See dealer for details.
4. Tires also covered under the Bumper-to-Bumper Warranty but are prorated based upon mileage. See dealer for warranty details.
5. If the vehicle has a warrantable failure, see your Owner's Manual for full details on the Courtesy Transportation program.
6. Customer maintenance item after 7,500 miles.



GM reserves the right to make changes at any time, without notice, in prices, colors, materials, equipment, specifications, models, and availability. Specifications, dimensions, measurements, ratings, and other numbers in this catalog and other printed materials provided at the dealership or affixed to vehicles are approximates based upon design and engineering drawings and prototypes and laboratory tests. Your vehicle may differ due to variations in manufacture and equipment. Since some information may have been updated since the time of printing, please check with your GM dealer for complete details. Some of the equipment shown or described throughout this publication may be available at extra cost, and/or is supplied by an independent supplier.

Copyright 2019 General Motors. All rights reserved. All text, images, graphics, and other materials in this publication are subject to the copyright and other intellectual property rights of General Motors. These materials may not be reproduced, distributed, or modified without the express written permission of General Motors. The marks appearing in this publication including, but not limited to: GM and the GM logo; Chevrolet and their respective logos, emblems, slogans, and vehicle model names and body designs; and other marks such as GM Fleet and Commercial are trademarks and/or service marks of General Motors, its subsidiaries, affiliates, or licensors.

For more detailed information, contact your District Sales Manager or see the online order guide at gmfleet.com/police.

GENERAL MOTORS FLEET

