

# Software Manual

# TMflow

Original Instruction

Software Version: 1.68



This Manual contains information of the Techman Robot product series (hereinafter referred to as the TM Robot). The information contained herein is the property of Omron Corporation (hereinafter referred to as the Corporation) and Techman Robot Inc. No part of this publication may be reproduced or copied in any way, shape or form without prior authorization from the Corporation. No information contained herein shall be considered an offer or commitment. It may be subject to change without notice. This Manual will be reviewed periodically. The Corporation will not be liable for any error or omission.

**TM** logo is registered trademark of TECHMAN ROBOT INC. and the company reserves the ownership of this manual and its copy and its copyrights.

Revision History Table .....	9
1. General.....	10
1.1 Overview .....	10
1.2 Warning and Caution Symbols.....	10
1.3 Safety Precautions .....	11
1.4 Validation and Responsibility .....	12
1.5 Limitation of Liability .....	12
1.6 Functional Note Symbol.....	12
2. Start up and Activation.....	13
2.1 Overview .....	13
2.2 Start Up .....	13
2.2.1 Plug in the Power .....	13
2.2.2 Start Up from Packing Pose .....	14
2.2.3 Standard Start Up .....	18
2.2.4 TM Robot HMI TMflow Operation .....	18
2.2.4.1 Local Operation Method .....	19
2.2.4.2 Wireless Access Point Connection Method .....	19
2.2.4.3 Wired Network Connection Method .....	20
3. Safety Settings .....	22
3.1 Overview .....	22
3.2 Safety Permission Settings.....	22
3.3 Safety Setting .....	22
3.3.1 Safety Stop Criteria .....	22
3.3.2 Safeguard Port Settings .....	24
3.3.2.1 Safeguard Port Setting .....	24
3.3.3 Collaborative Mode Setting .....	24
4. Start Your First Project.....	28
4.1 Overview .....	28
4.2 Initial Setting.....	28
4.3 M/A Mode and FreeBot.....	29
4.4 Build and Run Your First Project .....	30
4.5 Operation Mode.....	33
4.5.1 Auto Mode.....	33
4.5.2 Manual Mode .....	33
4.5.2.1 Manual Control Mode .....	33

4.5.2.2 Manual Trial Run Mod.....	34
4.5.3 Changing the Operation Mode .....	34
4.6 Hold to Run .....	34
4.7 Shutdown .....	35
5. Operation Interface.....	36
5.1 Overview .....	36
5.2 Login/Logout.....	36
5.3 Connection .....	37
5.3.1 Local Connection .....	37
5.3.2 Remote Connection .....	37
5.4 View .....	38
5.4.1 “Display Board” Page.....	38
5.4.2 “Flow” Page.....	39
5.4.3 “IO”Page .....	39
5.4.4 “Simulator” Page .....	39
5.4.5 “Status” Page .....	40
5.5 Run Setting.....	40
5.6 Project .....	41
5.6.1 Project Editing Toolbar .....	41
5.6.1.1 Create New Project.....	41
5.6.1.2 Save File (Project) .....	42
5.6.1.3 Open Project.....	42
5.6.1.4 Step Run .....	42
5.6.1.5 Point Manager .....	43
5.6.1.6 Base Manager .....	45
5.6.1.7 Controller.....	46
5.6.1.8 Variables List .....	49
5.6.1.9 EditBlock .....	49
5.6.1.10 Current Base and Base List .....	50
5.6.1.11 Current TCP and TCP List .....	50
5.6.1.12 Display Manager.....	51
5.6.2 Node Menu and Flow Editing Area .....	52
5.6.3 Project Function Menu .....	53
5.6.3.1 Search Function .....	53
5.6.3.2 Operation Space.....	54
5.6.3.3 ModbusDev .....	54

5.6.3.4 Set IO while Project Error .....	54
5.6.3.5 Set IO while Project Stop .....	54
5.6.3.6 Stop Watch .....	54
5.6.3.7 View.....	55
5.7 Robot Setting.....	55
5.7.1 Wizard.....	55
5.7.2 Vision Setting .....	56
5.7.3 TCP.....	56
5.7.4 IO Setting.....	56
5.7.5 Safety Setting.....	57
5.7.6 Controller .....	57
5.7.7 Speech.....	57
5.7.8 Gripper Button.....	58
5.7.9 Component .....	58
5.7.10 Operation Space .....	58
5.7.11 Command.....	58
5.7.12 Modbus .....	58
5.7.13 Posture Setting.....	59
5.7.14 Global Variables .....	59
5.8 System Setting .....	60
5.8.1 Language.....	60
5.8.2 System Update .....	61
5.8.3 Group.....	62
5.8.4 User Account.....	62
5.8.5 Network Setting.....	63
5.8.6 Import/Export .....	64
5.8.7 Date and Time.....	64
5.8.8 Administrator Setting .....	65
5.8.9 Network Services .....	65
5.8.10 Backup and Restore.....	66
6. Point and Base .....	67
6.1 Overview .....	67
6.2 Base and Right-hand Rule.....	68
6.2.1 Right-hand Rule .....	68
6.2.2 Types of Base .....	68
6.2.2.1 Robot Base.....	68

6.2.2.2 Vision Base.....	69
6.2.2.3 Custom Base.....	70
6.2.2.4 Tool Base.....	70
6.3 Point Parameter.....	71
6.3.1 Base Shift.....	72
6.3.2 Tool Shift.....	73
7. Create Base.....	75
7.1 Create Vision Base.....	75
7.2 Create a Custom Base.....	75
7.3 Create New Base Node.....	77
7.3.1 Create a New Base by Two Vision Bases.....	77
7.3.2 Create a New Base by Three Dynamic Points.....	78
8. Create End Tool.....	79
8.1 Overview.....	79
8.2 TCP Setting.....	80
8.2.1 Create Parameters of TCP with Hand Guidance Teaching.....	80
8.2.2 Create Tool Center Point by Input Parameters.....	83
8.3 End Tool Base.....	84
9. Motion Programming.....	85
9.1 Overview.....	85
9.2 Point to Point (PTP).....	86
9.2.1 PTP is the Fastest Way to Move.....	86
9.2.2 Speed of PTP Motion.....	86
9.2.3 Plan for PTP Movement.....	87
9.3 Line.....	87
9.3.1 Line Moves the Shortest Distance.....	87
9.3.2 Speed of Line Motion.....	87
9.3.3 Plan for Line Movement.....	88
9.4 Two Steps Motion(WayPoint).....	88
9.4.1 WayPoint.....	88
9.4.2 Plan for WayPoint Movement.....	89
9.5 Blending.....	90
9.5.1 Blending in Movement.....	90
9.5.2 Blending Speed Change Chart.....	90
9.5.3 Set the Blending Percentage.....	90
9.5.4 Set the Blending by Radius.....	91

9.6 Motion Nodes .....	92
9.6.1 Point Node .....	92
9.6.1.1 Generation Method of Point node .....	92
9.6.1.2 Point Node Setting .....	92
9.6.2 F-Point Node .....	93
9.6.3 Move Node .....	94
9.6.4 Circle Node .....	95
9.6.4.1 Circle Node Setting .....	95
9.6.4.2 Set Angle= 0° .....	96
9.6.4.3 Set Angle > 0° .....	96
9.6.5 Path Node .....	97
9.6.5.1 Path & PLine .....	97
9.6.5.2 Path Node Setting .....	98
9.6.5.3 Path File Import and Export .....	98
9.6.6 Pallet Node .....	99
9.6.7 Listen Node .....	101
10. Logic Programming .....	103
10.1 Overview .....	103
10.2 Variable System .....	103
10.2.1 Local Variables .....	103
10.2.1.1 Global Variables .....	105
10.3 Logic Nodes .....	107
10.3.1 SET Node .....	107
10.3.2 IF Node .....	109
10.3.3 WaitFor Node .....	110
10.3.4 Gateway Node .....	111
10.4 Process .....	112
10.4.1 Process Nodes .....	112
10.4.2 Subflow Node .....	114
10.4.3 Thread .....	116
11. Vision Node .....	117
12. Communication and Display .....	119
12.1 Modbus .....	119
12.1.1 Modbus System Hardware Structure .....	119
12.1.2 Modbus System Software Structure .....	120
12.1.2.1 Set Modbus TCP .....	120

12.1.2.2 Set Modbus RTU .....	120
12.1.3 Application of Modbus in Project .....	120
12.2 Network .....	124
12.3 IO .....	124
12.3.1 User Defined IO .....	125
12.3.2 External IO .....	125
12.3.3 Status IO .....	126
12.4 Command Node .....	127
12.4.1 TmComm Instruction Set.....	128
12.4.2 File Command.....	134
12.5 Log Node.....	139
12.6 Display Node .....	141
12.7 Voice Node .....	142
13. Component.....	143
14. Force Related Node.....	146
14.1 Compliance node.....	146
14.2 TouchStop Node .....	149
14.2.1 TouchStop- Compliance .....	149
14.2.2 TouchStop- Line .....	150
14.3 SmartInsert Node .....	151
14.3.1 Approaching .....	151
14.3.1.1 Approaching principle description .....	151
14.3.1.2 Approaching parameters setting .....	152
14.3.2 Searching.....	152
14.3.2.1 Searching Parameter Setting.....	154
14.3.3 Pushing.....	156
14.3.3.1 Pushing Principle Description .....	156
14.3.3.2 Pushing Parameter Setting.....	156
15. Operation Space.....	157
15.1 Overview .....	157
15.2 Operation Space Setting Page .....	158
15.3 Add / Modify Plane Page .....	159
15.4 Operation Space Setting Page in the Project Editing Page.....	162
16. Appendix Modbus List.....	164



## Revision History Table

Revision Code	Date	Revised Content
01	October 2018	Original release

# 1. General



## 1.1 Overview

TMflow is a graphical HMI. Its purpose is to provide users with complete, convenient and simple interface for robot motion and logic programming environments. Through the graphical HMI, users can simply manage and set the parameters of the robot, and use the graphical flow chart to plan the robot movement and process logic. At the same time, the interface design of TMflow also considers the operating habits of touch screens, allowing you to manage multiple robots from a single Windows tablet. Users and system integrators of TM Robot must read and fully understand this chapter before using this robot. In addition, before the user performs any operation on the robot in accordance with this manual, it is necessary to read and comply with the "Safety Manual" for the corresponding product's hardware and software version, and the "Hardware Installation Manual" for the corresponding hardware version, before the operation can be performed. If part of the operations and actions are due to the changes of new software design that resulted in differences of description between the "Hardware Installation Manual" for the corresponding hardware version and this manual, the contents of this manual shall prevail.

This manual applies to TMflow Version 1.68. Please confirm your software version before using and reading this manual. To check the software version, click  on the interface on TMflow.

## 1.2 Warning and Caution Symbols

The Table below shows the definitions of the warning and caution levels described in each paragraph of this Manual. Pay close attention to them when reading each paragraph, and observe them to avoid personal injuries or equipment damage.

	<b>DANGER:</b> Identifies an imminently hazardous situation which, if not avoided, is likely to result in serious injury, and might result in death or severe property damage.
	<b>WARNING:</b> Identifies a potentially hazardous situation which, if not avoided, will result in minor or moderate injury, and might result in serious injury, death, or significant property damage.
	<b>CAUTION:</b> Identifies a potentially hazardous situation which, if not avoided, might result in minor injury, moderate injury, or property damage.

### 1.3 Safety Precautions



#### **DANGER:**

This product can cause serious injury or death, or damage to itself and other equipment, if the following safety precautions are not observed:

- All personnel who install, operate, teach, program, or maintain the system must read the “Hardware installation Manual”, “Software Manual”, and “Safety Manual” according to the software and hardware version of this product, and complete a training course for their responsibilities in regard to the robot.



Read Manual Label; Impact Warning Label

- All personnel who design the robot system must read the “Hardware installation Manual”, “Software Manual”, and “Safety Manual” according to the software and hardware version of this product, and must comply with all local and national safety regulations for the location in which the robot is installed.
- Observing the “Intend of Use” section in “Safety Manual”.
- If the installation and application does not observe human-robot collaboration regulations of the safety regulations, the user is responsible for providing safety barriers around the robot to prevent anyone from accidentally coming into contact with the robot when it is in motion.
- Power to the robot and its power supply must be locked out and tagged out before any maintenance is performed.

## 1.4 Validation and Responsibility

The information provided in this Manual does not include how to design, install and operate a complete arm application, nor does it involve the peripheral devices that will affect the overall system safety. The design and installation of the complete system must comply with the standards and regulations for safety requirements in the country located. Users or integrators should understand safety laws and safety regulations in the local country, and avoid major risks existed in the entire system.

This includes but not limited to:

- Risk assessment of the entire system;
- Add other machines and additional safety mechanisms based on the definition of risk assessment;
- Set up appropriate safety mechanisms in the software;
- Ensure that users will not modify any safety-related measures;
- Ensure that all systems are correctly designed and installed;
- Label the instructions for use;
- Label the related marks related to arm installation and the contact information of the integrator;
- Collect all documents in the technical folder, including risk assessment and this Manual.

## 1.5 Limitation of Liability

Even if the safety instructions are followed, any safety-related information in the Manual shall not be considered as a guarantee that the TM Robot will not cause any personal injury or damage to the TM Robot.

## 1.6 Functional Note Symbol

The following table defines the functional note symbol marked in each paragraph in this manual. Read the paragraphs carefully to assist the improvement of programming efficiency.

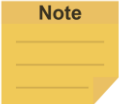
	<p><b>IMPORTANT:</b></p> <p>This mark symbol represents the relevant functional details reminder, to assist the programming and application</p>
	<p><b>NOTE:</b></p> <p>This mark symbol represents the relevant functional use tips, to assist the improvement of programming efficiency</p>

## 2. Start up and Activation

### 2.1 Overview

This manual instructs users of TM Robot to perform start up procedures for the first time. The user must first read and follow the "Safety Manual" for the corresponding product's software and hardware version, and the "Hardware Installation Manual" for the corresponding hardware version to install the TM Robot correctly and properly before executing the operation of this chapter, otherwise, it may result in serious risks.



#### **WARNING:**

The following chapters of this manual will describe how to install the TM Robot after unpacking the box. If it is your first time to install TM Robot without learning all the installation process starting from unpacking the new product, especially when the robot has been installed in a working environment, pay attention to the following items in order to perform first time installation and start up operation according to this manual:

1. In order to avoid the risks of resuming work caused by the changes of the original working environment and configuration, confirm with the responsible person for the working environment and keep all necessary configuration records, such as software settings and all hardware wirings.
2. Remove all IOs for the external connection of the Control BoxControl Box, including analog IO, digital IO, EtherCAT connection port and network ports. Remove all air lines or external power lines connecting to the optional equipment before Commissioning.
3. Remove all Control Box external USB interface, serial port, and external connection / external storage device connections of the network interface.
4. Uninstall any added objects / end-effectors installed to the end flange and any electrical connections between the end effector and the End Module / Control BoxControl Box.
5. Uninstall any hardware that is installed outside the robot body.

### 2.2 Start Up

#### 2.2.1 Plug in the Power

Plug the Power Cable of Control Box into the power socket.



#### **WARNING:**

For the operations from the product unpacking to plug the Power Cable of the Control Box into the power socket, read and follow the corresponding contents of the "Hardware Installation Manual".

## 2.2.2 Start Up from Packing Pose

**Step 1.** Press the Emergency Switch of the Robot Stick.

**Step 2.** Press the power button of the Robot Stick to start the power supply of the Control BoxControl Box.

**Step 3.** Release the Emergency Switch of the Robot Stick clockwise when the light on Robot Stick starts blinking.

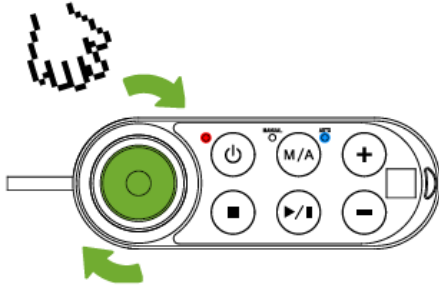

For the buttons, lights and switch on the Robot Stick, please refer to the Hardware Installation Manual.



**CAUTION:**

While booting up, if the Emergency Switch on the Robot Stick is kept pressed or the Emergency Stop Port is kept open, the boot process cannot be finished. Follow the instruction shown on the screen to restart the robot.



**CAUTION:**

If the Safeguard Port A: Safeguard Pause Port is kept open while booting up, the boot process cannot be accomplished. Follow the instruction shown on the screen to restart the robot.

**Step 4.** The three lights on the Robot Stick keep flashing.



**Step 5.** The Indication Light Ring of the End Module flashes red during startup.

**Step 6.** After the start up is completed, the Indication Light Ring of the End Module flashes in light blue, representing that it enters the Safe Start Up Mode.

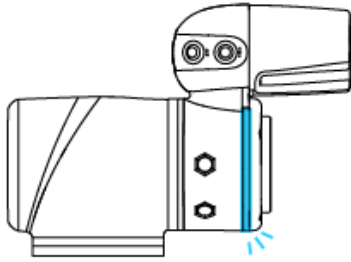

**Step 7.** Then, the user can hold the FREE Button at the end module to release the brakes and draft the robot to a relatively safe position. When starting the robot from the initial posture after unpacking, follow the illustration below to push each joint in sequence.

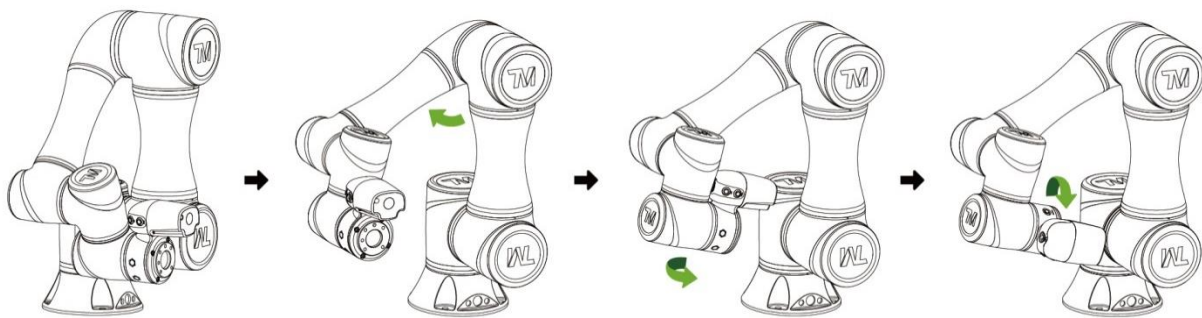

The recommended operating sequence of pushing the joints of TM Robot from Packing Pose to safe posture

**DANGER:**

Pay attention when the FREE button is pressed and the brake is released. The robot's body will sag again due to gravity. When the FREE button is pressed to unlock the brake, be sure to grasp the end of robot and expect the gravity sagging, and hold the end of robot, to prevent additional harm that already happened such as pinch injury of human body. If it is found at this moment that the robot itself cannot sustain the sagging of the robot body due to unstable grip or physical factors, release the FREE button immediately, and the brake of each robot joint will be locked again.

**DANGER:**

There should be no force compensation in Safe Start Up Mode. This means that it requires more force to move each joints directly against the motor drive.

**CAUTION:**

If you do not follow the above instructions to drag the robot to the safe posture shown in the above graph, continue to operate downwards to release the Emergency Switch, this may cause certain joints of the robot (especially the fifth joint) to be outside the joint angle limit when the robot returns to a normal state. At this time, the robot will not be able to return correctly and the red light will be on. In this condition, press the Emergency Switch again and repeat this step to the correct safe posture as shown in the graph.



**Step 8.** Press and hold the Stop Button on the Robot Stick for about three seconds, the robot will enter the calibration process. At this time, each joint of the robot will move slightly to calibrate. After the calibration is completed, the Indication Light Ring of the End Module will return to blue light, representing that the robot has entered the Auto Mode successfully and it can be used normally.

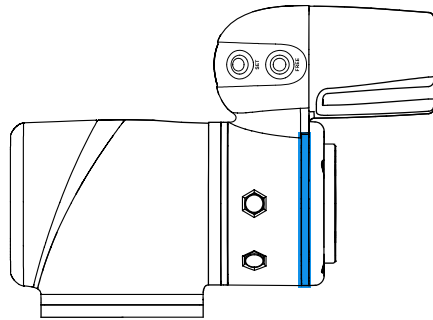

**CAUTION:**

When the start up completed from the Packing Pose, use the TMflow controller page to move the robot posture to the origin first (each joint angle: 0, 0, 0, 0, 0, 0), then you can use the FreeBot teaching to drag the robot to the Normal Pose (each joint angle: 0, 0, 90, 0, 90, 0), as shown in the image below. PPay attention to the Normal Pose and the safe posture after unpacking the box; the pointing direction of the second joint module of both postures are opposite.

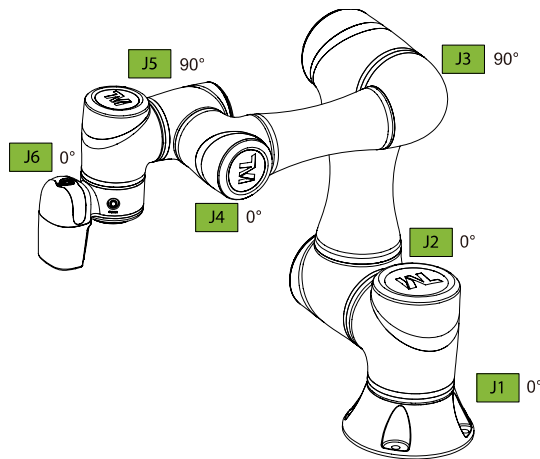

### 2.2.3 Standard Start Up

**Step 1.** Confirm whether the robot's posture is safe.

**Step 2.** Check that the Emergency Switch of Robot Stick is released.

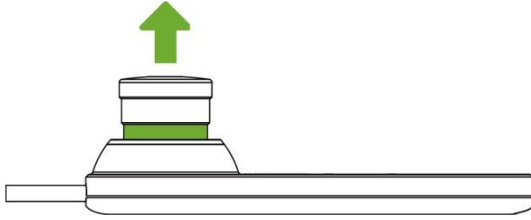

**Step 3.** Press the power button of the Robot Stick to start the robot.



**CAUTION:**

While booting up, if the Emergency Switch on the Robot Stick is kept pressed or the Emergency Stop Port is kept open, the boot process cannot be finished. Follow the instruction shown on the screen to restart the robot.



**CAUTION:**

If the Safeguard Port A: Safeguard Pause Port is kept open while booting up, the boot process cannot be accomplished. Follow the instruction shown on the screen to restart the robot.

**Step 4.** Confirm the screen on the Control Box. The display shows the system enters the start up mode and the power light on the Robot Stick keeps flashing.

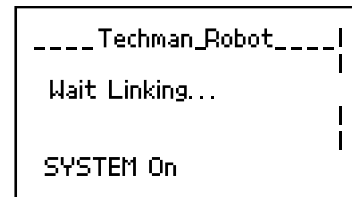
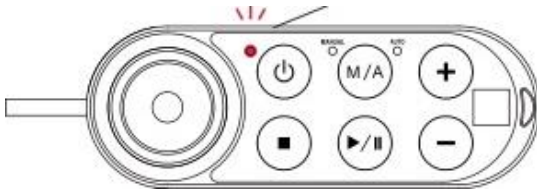

**Step 5.** When the controller is starting up, the Indication Light Ring of the End Module displays flashing red light. During the process, the robot will run automatic calibration, and each joint of the robot will move slightly to calibrate.

**Step 6.** After the controller start up completed, the Indication Light Ring of the End Module will constantly display blue light; the robot can be used normally at this time.

### 2.2.4 TM Robot HMI TMflow Operation

TMflow, the HMI, and the TM Robot can be connected in three ways: Connect with the monitor, keyboard and mouse to the Control Box, which enables to start TMflow; or download the TMflow Client from customer area of the official website, and then install on a Windows Based computer (e.g. Windows Laptop/ Windows Tablet), after which it can be connected to robot either by wire or wireless.

### 2.2.4.1 Local Operation Method

**Step 1.** Connect the screen, mouse and keyboard to the Control Box.

**Step 2.** Click the icon in the upper left of the Human-Machine Operation Interface, call out the function menu, and click to Login. ("Administrator" default is not set with password, click OK to login directly.)

**Step 3.** Click "Get Control" to get control of the robot

### 2.2.4.2 Wireless Access Point Connection Method

**Step 1.** Install TMflow on client device.

**Step 2.** Connect the robot to the same physical AP or entity AP of the same network segment.

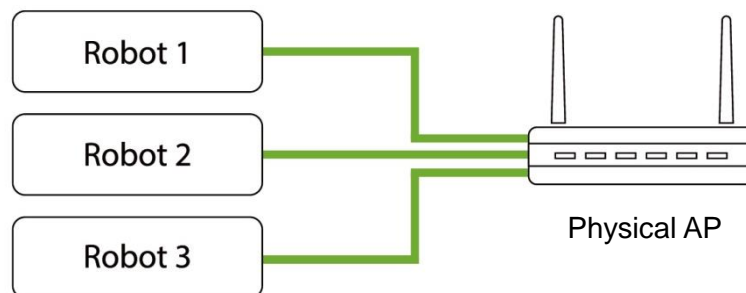

**Step 3.** Connect the client network to the above local area network.

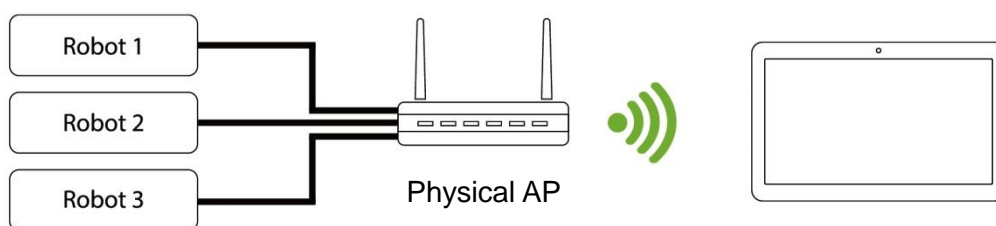

**Step 4.** Open TMflow on the client device, click the upper left corner  to refresh the robot list, and wait for the corresponding Robot name to appear on the connection screen.

**Step 5.** Click the robot icon twice to connect with the robot. Pay attention that all the robots in this network segment will appear in the screen. The user can distinguish which robot to be connected by the robot's Robot ID (the number displayed below the QR code on the Robot Stick).

**Step 6.** When the robot connection is successful, the  icon will appear in the screen on the robot and the robot icon will appear in the upper right corner.

**Step 7.** Click the icon in the upper left corner of the TMflow, call out the function menu and click to Login.

**Step 8.** "Administrator" default is not set with password, click OK to login directly.

**Step 9.** Click "Get Control" to get control of the robot.



**CAUTION:**

Do not mistakenly insert the network cable into the EtherCAT dedicated port of the Control Box. This action will trigger a robot error.

#### 2.2.4.3 Wired Network Connection Method

**Step 1.** Install TMflow on the client device.

**Step 2.** Connect the robot and client device to the same physical AP or the physical AP on the same network segment, or connect the two ends of the network wires to the robot Control Box and Client.

**Step 3.** Connect the client network to the above local area network.

**Step 4.** Open TMflow on the client device, click the upper left corner  to refresh the robot list, and wait for the corresponding Robot ID to appear on the connection screen.

**Step 5.** Click the robot icon twice to connect with the robot. Pay attention that all robots in this network segment would appear in the screen. The user can distinguish which robot to be connected by the robot's Robot ID.

**Step 6.** When the robot connection is successful, the icon  will appear on the robot in the screen and the icon of robot appears on the upper right corner.

**Step 7.** Click the icon in the upper left corner of the Human-Machine Operation Interface, call out the function menu and click to Login.

**Step 8.** "Administrator" default is not set with password, click OK to login directly.

**Step 9.** Click “Get Control” to get control of the robot.

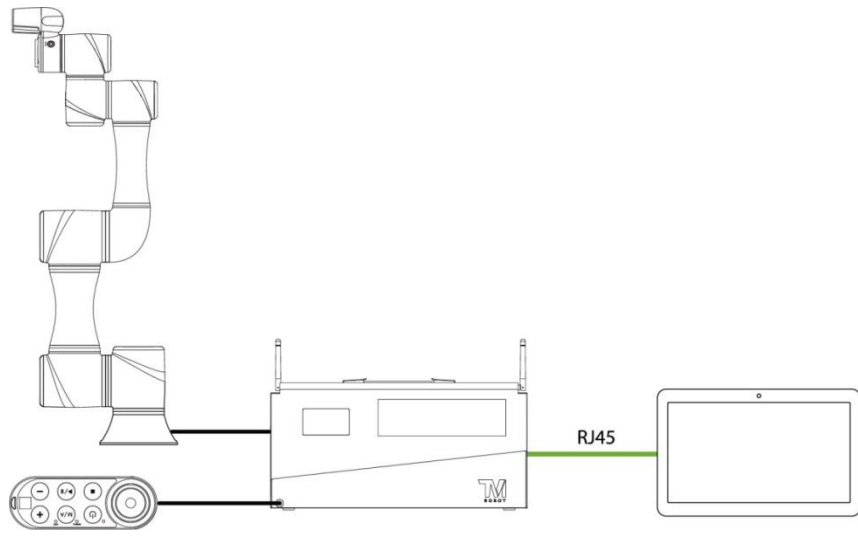
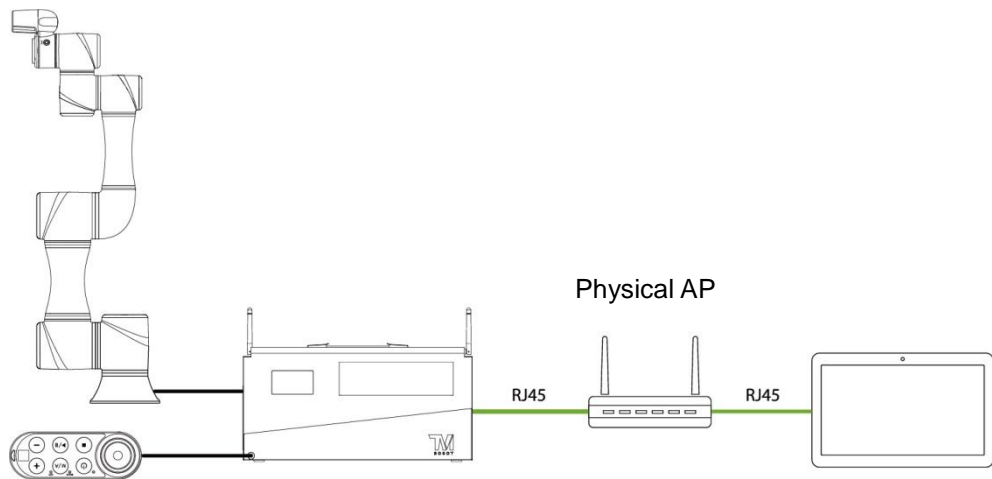

## 3. Safety Settings

### 3.1 Overview

This chapter will introduce safety settings interface of the TM Robot, including the Safety Permission Settings and Safety Setting.

### 3.2 Safety Permission Settings

The user of TM Robot must set appropriate account password permissions before starting to use the TM Robot, with appropriate arrangements for access to operator permission for safety configuration.

When the user has completed the startup and activation according to the previous chapter, and enters the TMflow interface with the default account password to get the control of robot, click  in the upper left corner of the interface to open the left sidebar (the "Function Menu") and click the "Setting" of the Function Menu to enter the setting page, an option labeled as "Safety Settings" can be seen on this page. This is the safety setting operation area of the product. In addition, the same pages are all important settings for the robot; if altered arbitrarily, it will cause danger during operation. For proper permission settings, refer to sections 5.8.3 "Group" and 5.8.4 "User Account" in Chapter 5 "Operation Interface" to create accounts for personnel authorized to access the safety related setting permissions and give them permission to access the "Settings" page, and set all other accounts / groups prohibited to access the "Settings" page to change the safety permission settings.

### 3.3 Safety Setting

After accessed the "Safety Settings" page, it can be seen that the menus are divided into three functional blocks: "Safety Stop Criteria", "Safeguard Port Setting", and "Collaborative Mode".

#### 3.3.1 Safety Stop Criteria

In this page, the user can set the TCP speed of the robot, the force of the TCP, the position of each joint, the joint speed, the joint torque, etc., the related physical meanings and the definition of the safety function and the precautions that they represent, read and follow the instructions in the "Safety Manual" and for the corresponding software and hardware versions, before the operation or setting can be performed.

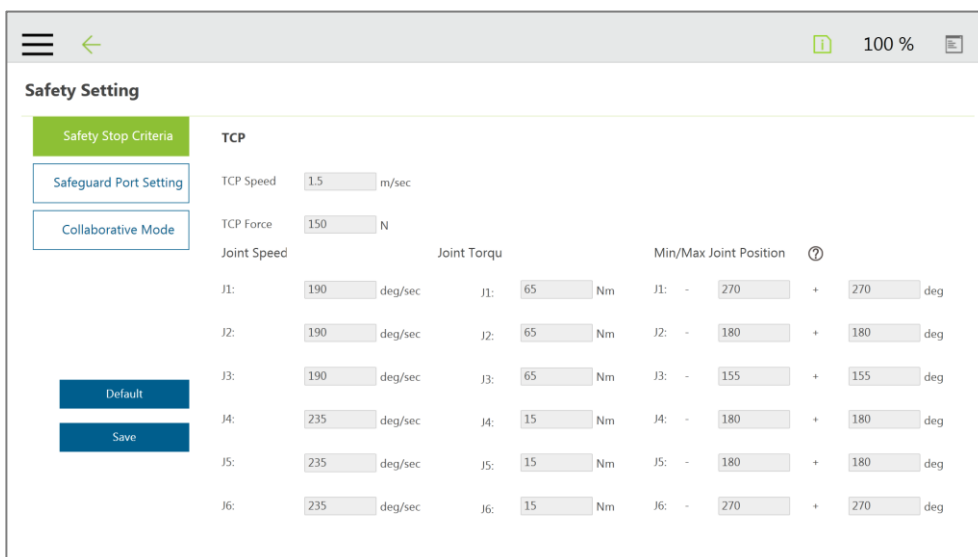

**CAUTION:**

**Angle Setting:**

For example, when the first joint position is set to 270° and -270°, then the angle range in 270°~ 271° and -270°~ -271° will become reducing range shown as the blue area in the figure. When the first joint move into this range, the basic moving speed of the robot will be switched to 250mm/sec for path motion and 5% for PTP motion, to form an angle buffer region to prevent possible overshoot to the joint limit. At the same time, the angle range in 271°~ 274° and -271°~ -274° is the 2nd buffer range for joint limit as the red area in the figure. When the joint angle arrives this area robot will stop moving. Users can only operate the robot by pressing FREE Button to make the robot leave this area.

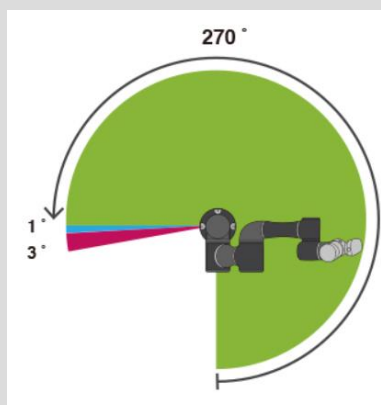

**CAUTION:**

For different TM Robot models the maximum angle limits of each joint may be different. Refer to the product specifications according to the product model and hardware version.

### 3.3.2 Safeguard Port Settings

This block is to set up the function of Safeguard Port for the TM Robot. Due to the design differences of hardware versions, there are differences in the operation interface displayed in this block between different hardware. Concerning the electrical connection of the Safeguard Port, refer to the relevant section of the "Hardware Installation Manual" for the corresponding hardware version.

#### 3.3.2.1 Safeguard Port Setting

Safeguard Port has a total of two types with Safeguard Port A: Safeguard Pause Port, and Safeguard Port B: Collaborative Mode Port. For the definition of each safeguard, refer to the "Safety Manual" for the corresponding software and hardware version. This setting will set up the resume mechanism of Safeguard Port A: Safeguard Pause Port. Pay attention that the user should set up this item appropriately according to the risk assessment.

**Manual Reset (recommended):** When you choose Manual Reset, after the robot has been paused through Safeguard Port A: Safeguard Pause Port, even if the trigger condition is removed, the user can only operate the Play/Pause Button or the same action from the Robot Stick to release the pause and return to the original project process and project speed.

**Auto Reset:** When you choose Auto Reset, after the robot has been paused through the Safeguard, once the trigger condition is removed, the robot will automatically release the pause and return to the original project process and project speed.

#### 3.3.3 Collaborative Mode Setting

When TM Robot is running in Collaborative Mode, it will run at a slower speed and a lower joint torque stop criteria according to the user's settings. At this time, a purple light will be added to the robot's light signal for the user to distinguish whether the robot has entered Collaborative Mode.



**DANGER:**

Pay attention so that the functions described in this section are only to assist the user in setting the collaborative safety parameters and settings more conveniently. The user should still perform complete risk assessment according to the robot use environment and conditions before the robot can be used. TM Robot clearly specifies the following potential residual risks: There is a risk that causes the robot to hit human body at full speed due to improper use of safe space settings or by running incorrect projects.





**DANGER:**

If using the Compliance function in TMflow it is not controlled by Collaborative Mode. The robot will still run Compliance function according to the force you set. If you want to use Compliance function in Collaborative Mode, complete a complete risk assessment and set appropriate force values.

The parameter setting of Collaborative Mode can be divided into two parts: one is “Body Region Risk Setting” and the other is “Limit Value Setting”. The “Body Region Risk Setting” page is shown in the figure below.

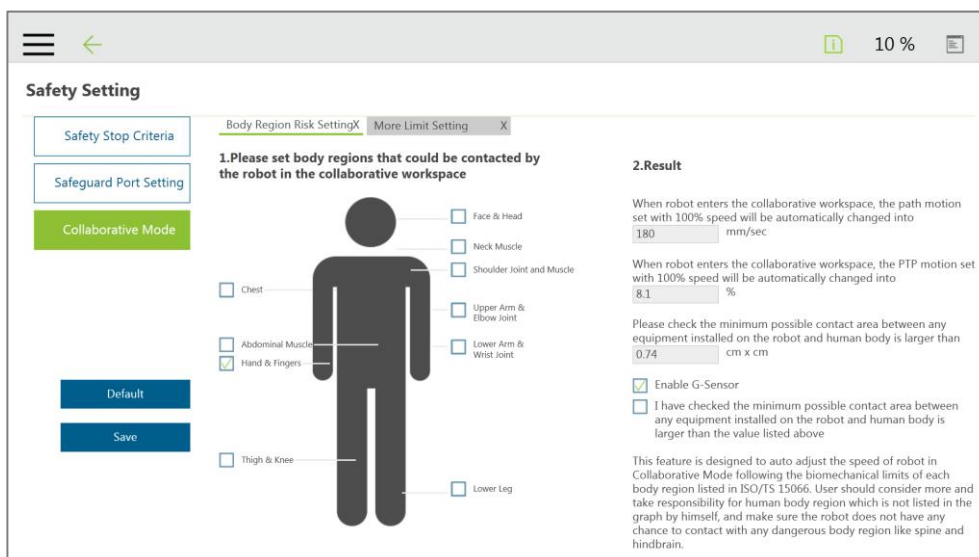

For the part of “Body Region Risk Setting”, the user can set the human body region that may be in contact with the robot in collaborative workspace according to the requirements. The calculation result on the right side of this interface displays the robot's running speed in the Collaborative Mode. The setting value can be saved after being confirmed by the user. The calculation result includes the value of the automatic reduced moving speed, the value of the automatic reduced point-to-point movement speed, the minimum possible contact area between the robot's external device and human body when entering the Collaborative Mode. The user shall check the confirmation field in the lower right corner before saving the setting value, to confirm the area where the robot's external device may in contact with the human body is larger than or equal to the area confirmation value.



**DANGER:**

This function is designed to auto adjust the speed of robot in Collaborative Mode following the biomechanical limits of each body region listed in ISO/TS 15066. The user should consider more and take responsibility for human body regions not listed in the graph by themselves. Also, make sure the robot does not have any chance to contact with any dangerous body region like spine and hindbrain.

It should be noted that although the user can correct the calculation result of this region, but it can only be set smaller. If the user needs to set more detailed parameters, the user can go to "More Limit Setting Page" to make corrections. The upper limit setting page is shown in the figure below.

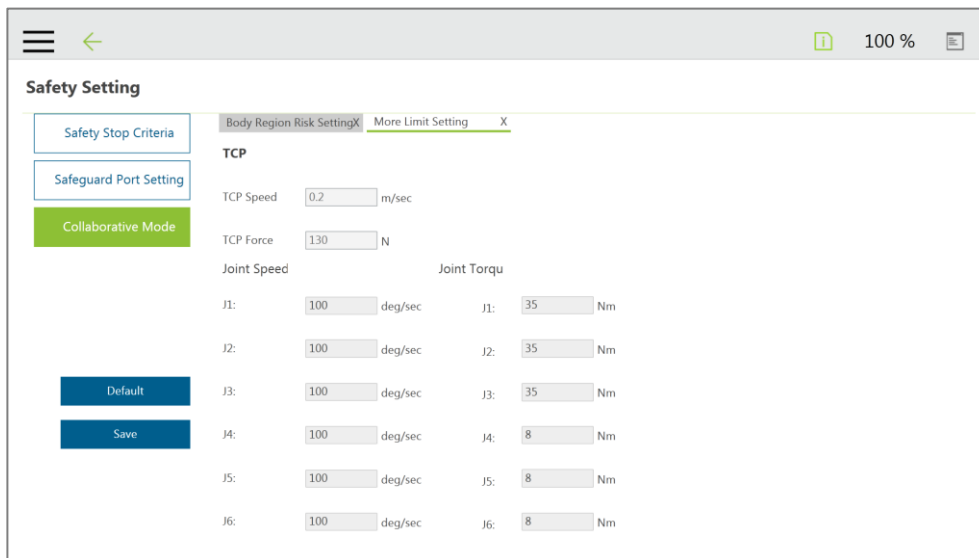

In the setting page of this Collaborative Mode, the user can set the joint speed, joint torque of robot, but it should be noted that the setting value of this region must be smaller than the setting value of the standard mode; the setting value can be saved after confirmed by the user.

## 4. Start Your First Project

### 4.1 Overview

This chapter will describe how to create and run your first project. Only when you have read all instruction first and have a full understand about the content of this manual and correctly set the TM Robots according to the contents of Chapters 2 and 3, the operation of this chapter can be performed.

### 4.2 Initial Setting

When your device is connected to the TM robot for the first time, follow the wizard steps to complete the following settings:

**Step 1.** Follow the steps to set up the robot.

**Step 2.** Select the interface language.

**Step 3.** Set the system time.

**Step 4.** Network settings.

**Step 5.** Perform voice settings.

Please click the Function Menu>Settings>Wizard to reset if required.

### 4.3 M/A Mode and FreeBot

Please confirm the Operation Mode of the robot at this time. Please see the Mode Indicator on the Robot Stick, and identify whether the lamp position is marked as Manual (Manual Mode) or Auto (Auto Mode). At the same time, it can also be identified by the Indication Light Ring of the End Module, where green light is Manual Mode, and the blue light is Auto Mode, if it is still in Auto Mode, press the M/A Mode Switch Button on the Robot Stick to switch to the Manual Mode to perform the follow-up operations of this chapter. When the indicator of the M/A Mode Switch Button is Green, the Indication Light Ring of the End Module is green, it is Manual Mode.

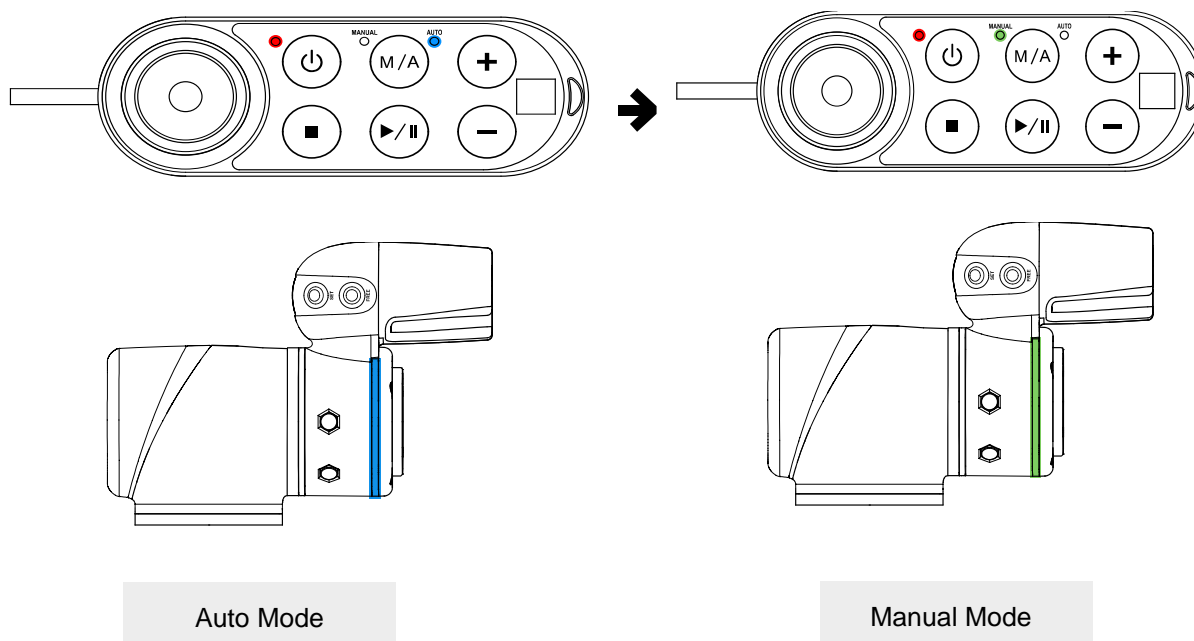

In the Manual Mode, press the FREE button to hand guiding the robot. The hand guiding function is only limited to the Manual Mode.

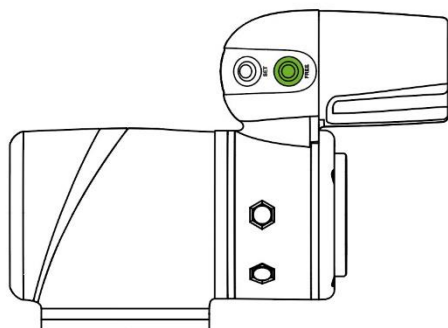

## 4.4 Build and Run Your First Project

If this is the first time you are unpacking the TM Robot, there will be no project in the robot. You can build your first project according to the instructions of this section. The following project target is to run back and forth between two points (P1 and P2). The setting method is as follows:



### **DANGER:**

Only when you have read all instruction first and have a full understand about the content of this manual and correctly set the TM Robot according to the contents of Chapters 2 and 3, the operation of this chapter can be performed.

**Step 1.** Please confirm the Operation Mode of the robot. If it is not in Manual Mode, refer to "M/A Mode and FreeBot" section to switch to Manual Mode.

**Step 2.** Select "Project" below the "Function Menu" and start entering the Project Editing Page.

**Step 3.** Choose to create a new project and enter the project name.



### **CAUTION:**

The project name rule only supports case-sensitive letters (A-Z, a-z), numbers (0-9), and the characters "&" and "\_".

**Step 4.** Enter the project name.

**Step 5.** Press the FREE button to move the robot to any point by hand guiding, press the POINT button, to let the project flow recording the point. You can see that the robot automatically names this point as P1 and has been automatically added after the Start Node and auto highlighted.

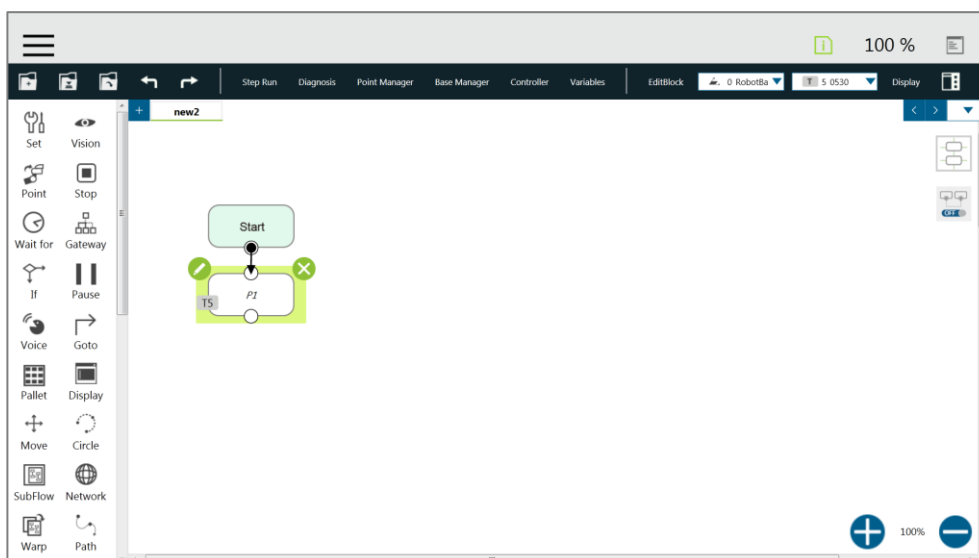

**Step 6.** Press the FREE button and move the robot to any other point by hand guiding. Press the POINT button to record this point and generate P2.

**Step 7.** Drag the Goto Node on the left side to the flowchart.

**Step 8.** Choose the Node that you want to Goto .

**Step 9.** Press the “Save” button to complete the project editing.

**Step 10.** Press the Play/Pause Button on the Robot Stick in the Project Eediting Page to start running the project, at this time, the Indication Light Ring will flash green. Each time when you start running project from Manual Mode, the Robot Stick looks as follows

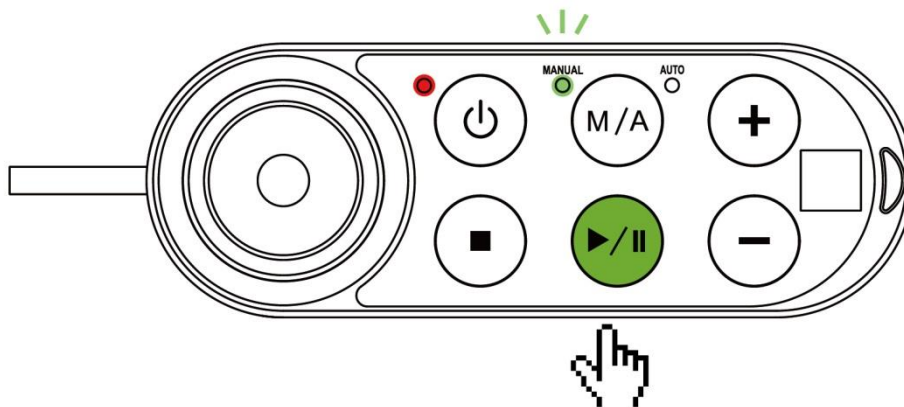

**Step 11.** Trial Run, the project speed of the project will be forced to change to 10% to ensure safety.

**Step 12.** Press the + button (increase running speed) / – button (decrease running speed) on the Robot Stick, to increase or decrease the Project Speed of the robot, adjust the speed of the robot here to the speed that you think is appropriate.(You can find out the set Project Speed from the % number displayed on the upper right corner of the HMI)

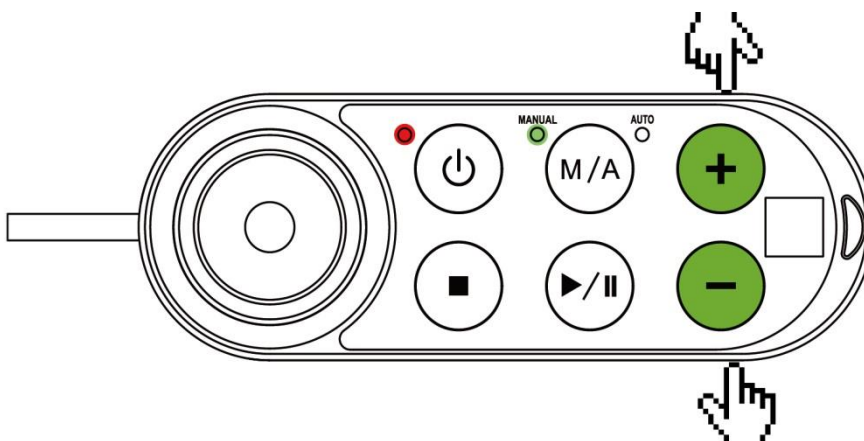

**Step 13.** After set your preferred project speed, press and hold the M/A Mode Switch Button (do not stop the project). When the two indicator positions on the Robot Stick begin to flash, press the +/- buttons on the Robot Stick in this order: "+ - + + -" to unlock. After unlocking, the robot will switch to Auto Mode to complete the trial run, the robot will save the Project Speed at this time as the Project Speed when running Auto Mode. Remember that if you perform trial run in Manual Mode again, the Project Speed will be forced to change back to 10%. You must operate this step again to set the Project Speed.



**CAUTION:**

You can not change Project Speed when running Auto Mode.

**Step 14.** When the Stop Button on the Robot Stick is pressed, its Project Speed is maintained at one you set. And the project will be labeled as "Tested".

**Step 15.** If the Play/Pause Button is pressed again in Auto Mode, the speed remains running at the Project Speed you set and the speed cannot be changed.

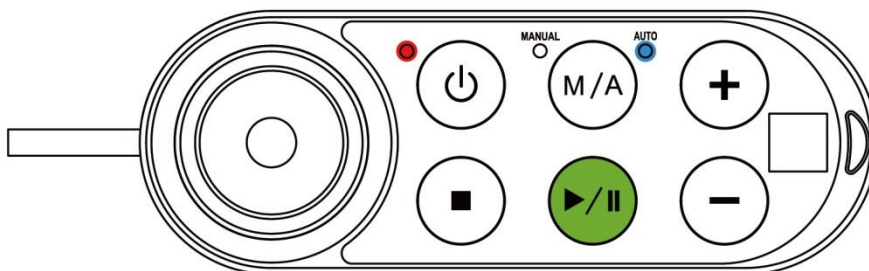

**Step 16.** Congratulations on your successful completion of project editing and running. Press the Stop Button on the Robot Stick to stop running of the project.

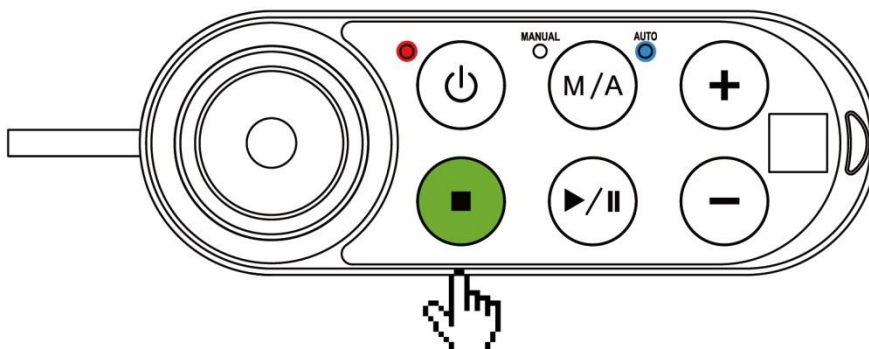



**WARNING:**

Before completing the adequate training, exploratory self-constructing project and then conduct the project running may lead to body collision or human injuries due to the unintended actions.

## 4.5 Operation Mode

TM Robot comes with two operation modes: Manual Mode and Auto Mode. Current mode can be determined visually via the Mode Indicator (see Hardware installation Manual) on the Robot Stick, and the color of the Indication Light Ring on the robot's End Module. (see Hardware installation Manual) The robot starts in Auto Mode.

### 4.5.1 Auto Mode

When the robot is in Auto Mode the Indication Light Ring on the End Module is blue and the Mode Indicator on the Robot Stick is in the Auto position. Under Auto mode, pressing the Play/Pause Button on the Robot Stick runs or pauses the project. Robot speed is determined by the Project Speed. The FREE button of the End Module does not work under Auto Mode so there is no guiding by hand.

### 4.5.2 Manual Mode

When the robot is in Manual Mode the Indication Light Ring on the End Module is green and the Mode Indicator on the Robot Stick is in the Manual position. Manual Mode can be further broken down into Manual Control Mode and Manual Trial Run Mode. The user can tell the difference using the status of the green Indication Light Ring on the End Module as well. Constant green light indicates Manual Control Mode while flashing green light indicates Manual Trial Run Mode.

#### 4.5.2.1 Manual Control Mode

In Manual Mode, if the robot is not moving then it is in Manual Control mode. Press the FREE button on the End Module to guide the robot by hand guiding or use the "Controller" page to jog the robot. When the robot is in Manual Control Mode, all robot motion will be limited to less than 250mm/sec. If the robot speed exceeds 250mm/sec then it will stop on an error. In addition, Hand Guiding Mode can only be activated from Manual Control Mode. The FREE button on the End Module can be pressed to move the robot by Hand Guiding.

#### 4.5.2.2 Manual Trial Run Mod

When the user is in the HMI's project editing page, pressing the Play/Pause button on the Robot Stick enters Manual Trial Run Mode. The 250mm/sec speed limit does not apply while editing projects in Manual Trial Run Mode but the project run speed will be reduced to 10% during each trial run. The add/subtract buttons on the Robot Stick can be used to adjust the project run speed in Manual Trial Run Mode. Each button press increases or decreases project run speed by 5%. This is used to adjust the project run speed.

#### 4.5.3 Changing the Operation Mode

To change the Operation Mode of the robot, use the Mode Switch Button on the robot control to cycle between Auto/Manual modes. The system cannot be changed from Auto to Manual Mode while the robot is running a project in Auto mode. The robot must be stopped by pressing the Stop Button on the Robot Stick before it can be switched to Manual mode. To switch from any Manual Mode (Manual Control or Trial Run) to Auto mode, hold down the Mode Switch Button. Once both Mode Indicator lights on the Robot Stick start blinking, follow the "+ - + -" sequence and press the Add/Subtract buttons on the Robot Stick to unlock and switch to Auto mode. When the robot is switched from Manual Trial Run Mode to Auto mode, the Project Speed will be set to the default Project Speed. In other words, the running speed in Auto Mode for this project will now be fixed unless it is changed by another trial run.

#### 4.6 Hold to Run

When the TM Robot is in Manual Control Mode it can several jogging function, including:

- joint angle movement
- Robot Base end movement
- Tool Base end movement
- self-defined base end movement
- move to visual initial position
- visual servo action
- step run
- move to point
- hand guiding
- other functions

In these functions, the safety of TM Robot is enhanced by Hold to Run design. Hold to Run in TM Robot's system is divided into two categories. When performing higher risk control operation, various functions shall be operated by the Hold to Run design using the physical buttons on the Robot Stick.

The first category is to jog the robot by continuously pressing the Plus / Minus Button of the Robot Stick. The second category is to jog the robot to move by continuously pressing the software button on the TMflow. Once the physical button or software button is released half way, the robot will stop operation immediately, and will continue operation when pressed again. Some of the functions have two categories of Hold to Run functions. The user can choose one of above functions to implement. If user chooses to use the buttons on TMflow connected with the robot through TCP/IP or Wi-Fi, the TM Robot will automatically stop your control of the robot and stop the robot operation when the connection is broken. Note that, depending on the quality of connection, there may be a maximum detection delay of disconnection of 0.7 seconds. It may cause the robot to continue to move along the original Hold to Run command after you release the software button. If user chooses physical button to perform Hold to Run function, the detection time of releasing the button is 30ms by the system. Therefore, in the case of control operations of higher risk, the Robot Stick should be used to operate each Hold to Run function.

#### 4.7 Shutdown

There are two shutdown methods:

##### Method 1:

Press "Shutdown" at the bottom left of the "Function Menu". A warning window "Do you want to shut down remote robot?" pops up. Press "OK" to shut down properly.

##### Method 2:

Press and hold the Power Button of the Robot Stick, when you hear a "beep beep" sound, the Power Button can be released. The Power Indicator of the Robot Stick is flashing red and the robot performs shutdown.

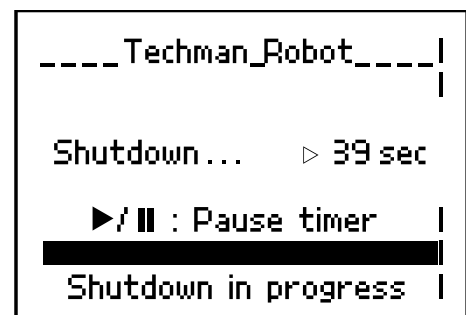
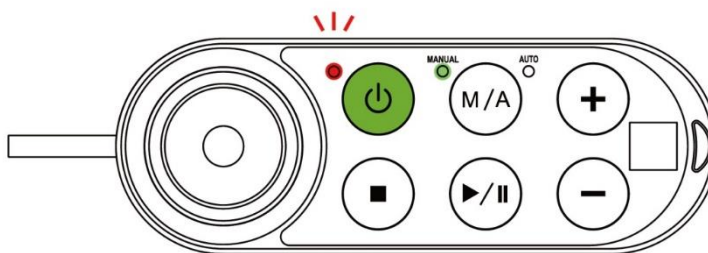

##### DANGER:

The below Shutdown methods are prohibited:

1. Unplug the power plug directly
2. Loosen the power cord of Control Box directly
3. Loosen the power of robot body directly

## 5. Operation Interface

### 5.1 Overview

The first chapter will introduce the operation interface of TMflow, including the icons in the “Function Menu”: “Login/Logout”, “Connect”, “View”, “Run Setting”, “Project”, “Setting”, and “System”.

### 5.2 Login/Logout

After waiting for the start up completed, click on the top left corner  to expand the Function Menu.

The listed icons from top to bottom are:

- “Login/Logout” – Login/Logout to start using the robotic arm,
- “Connect” - available robot list, “View” - display page when project is running,
- “Run Setting” - project list and default project to run,
- “Project” - create or edit project,
- Setting - robot setting,
- System - system setting,
- Shutdown - shut down robotic arm, as shown in the graph below.

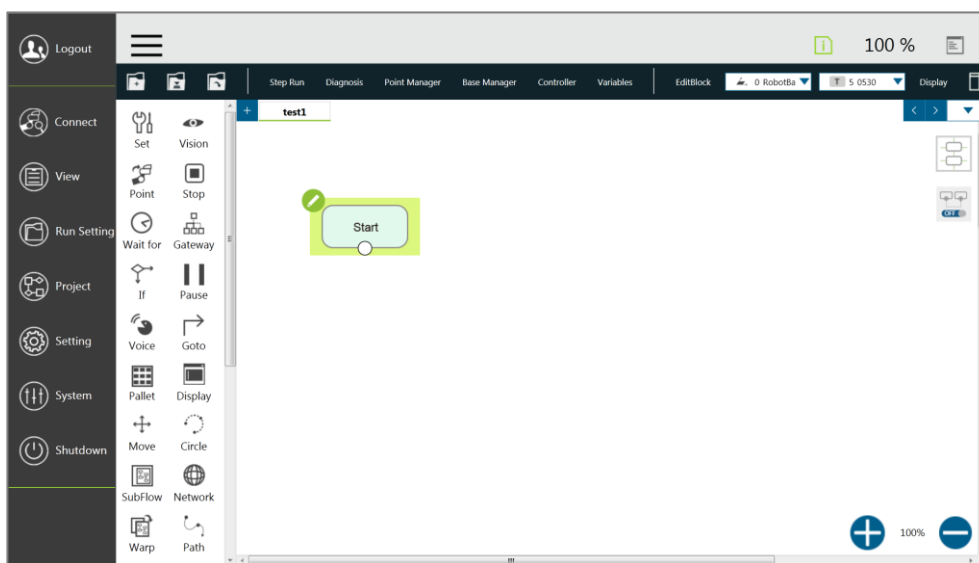

Function Menu

The login window will pop up when clicking Login. Please enter your account number and password to start using the robotic arm.



#### **CAUTION:**

Default account is “administrator”, default password is blank.

Please refer to Chapter 2 for the detail operation method from start up to complete login: Start up and Activation

## 5.3 Connection

### 5.3.1 Local Connection

If you control the robot with the screen, keyboard and mouse with the Control Box, follow the instructions below to log in and connect.

After completed login, click the “Get Control” below the robot to get control. To release control, click “Release Control” again to release control. Please refer to Chapter 2 for detail operation method: “Start up and Activation”

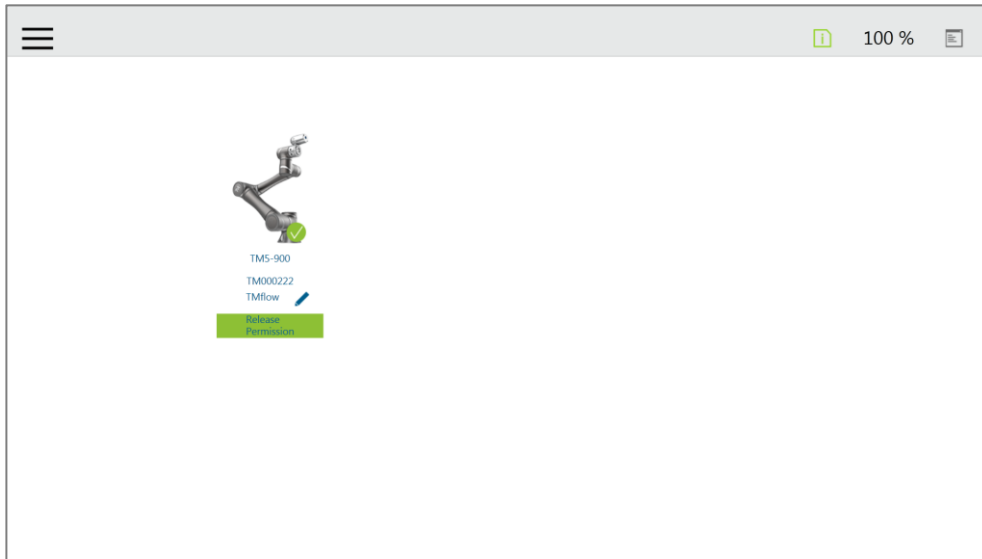

Get/Release Control (Local)

### 5.3.2 Remote Connection

If you control the robot through your own device (desktop computer, laptop, tablet), follow the instructions below before login.

Please click the upper left corner  to refresh the robot list, the robot can be connected will be displayed in the robot list.

After the connection is completed, the  symbol in the lower right corner of the robot can be seen. Login can be started after the connection is completed.

After login is completed, click the “Get Control” below the robot to get control. If to release the control, click “Release Control” again to release control. Please refer to Chapter2 for detail operation method: “Start up and Activation”

## 5.4 View

In the view page, the user can monitor project progress and the robot, as the figure below from left to right are the “Display Panel”, “IO”, “Simulator” and “Status”.

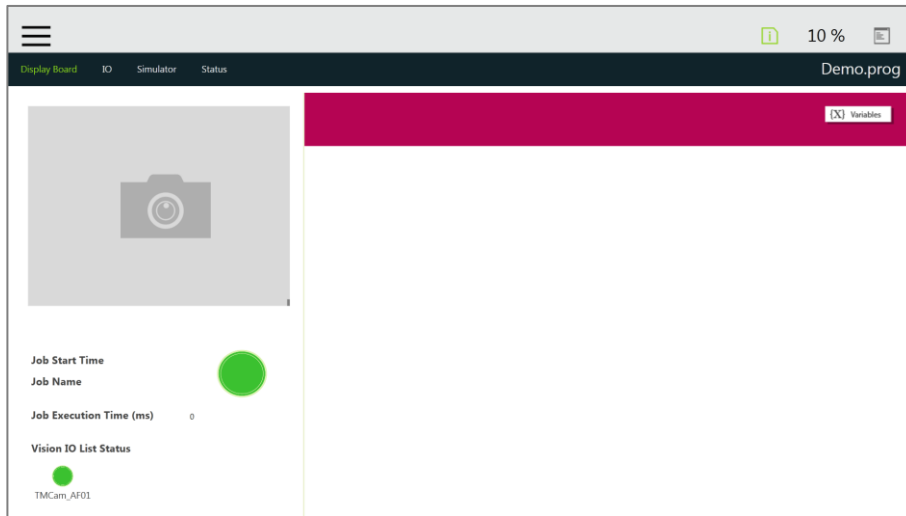

“View” Page



### IMPORTANT:

The robot can provide remote and local multi-logins, but only one person can get Control at a time.

### 5.4.1 “Display Board” Page

In the Display Board page, the user can monitor the project running status, including the vision job result at left and the status display at right. The status display contains both description and variable that can be switched by  and  buttons on the upper right corner, the description content can be changed through the Display Node, the variable can be changed through the Display Management in the project.

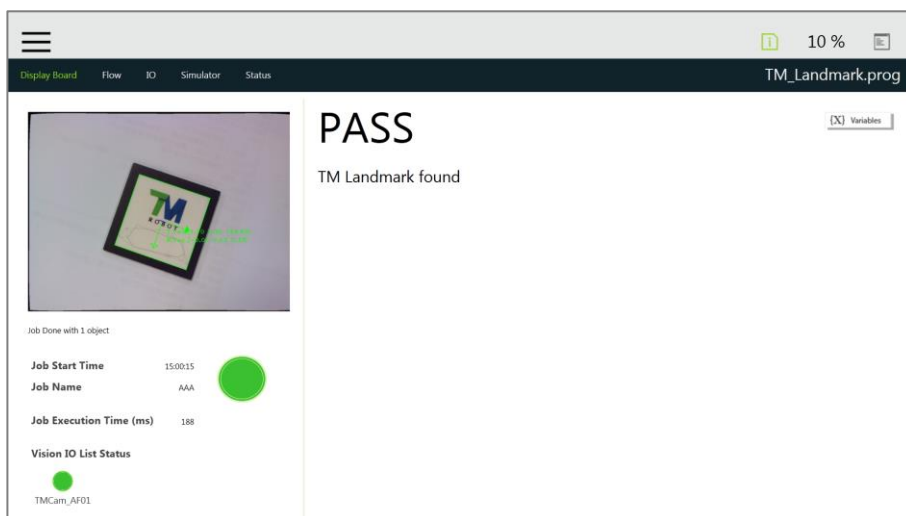

“Display Board” page

#### 5.4.2 “Flow” Page

In Manual Mode, the flow will be displayed and indicate the current process running position when the project is running. Through this page, the user can conveniently monitor the process as well as properly optimize and modify the process. In Auto Mode, this page will not show.

#### 5.4.3 “IO”Page

The IO page provides IO status monitoring and operation tools for the user, capable of monitoring the status of digital/analog input, and operate the digital and analog outputs in this page. When the project is running, the IO is controlled by the project and cannot be changed manually.

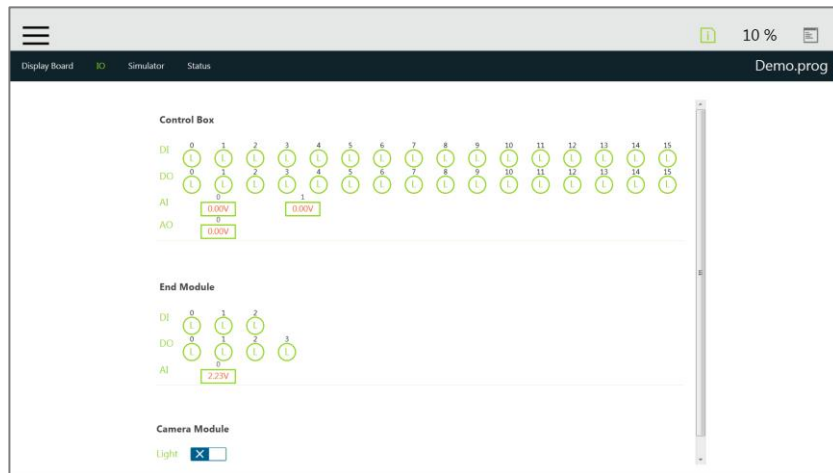

“IO” page

#### 5.4.4 “Simulator” Page

In the “Simulator” page, the user can monitor the current robot posture. Press Ctrl on the keyboard plus the right mouse button can rotate the 3D model, Ctrl plus the left mouse button to zoom in and out of the 3D model, and Ctrl plus the mouse double or middle button to move the 3D model.

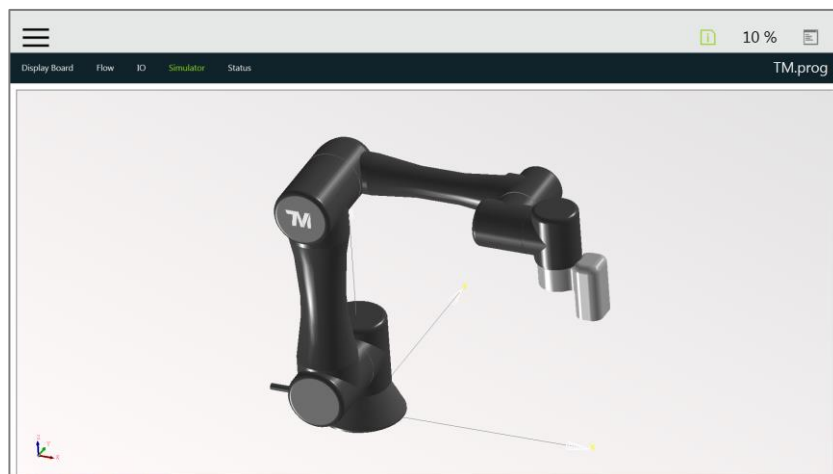

“Simulator” Page

### 5.4.5 “Status” Page

In the “Status” page, the controller temperature, voltage of the robot, power consumption of the robot, robot current, IO current of the Control Box, and the tool side I/O current can be monitored, and the currently running project or preset project will be displayed on the upper right corner.

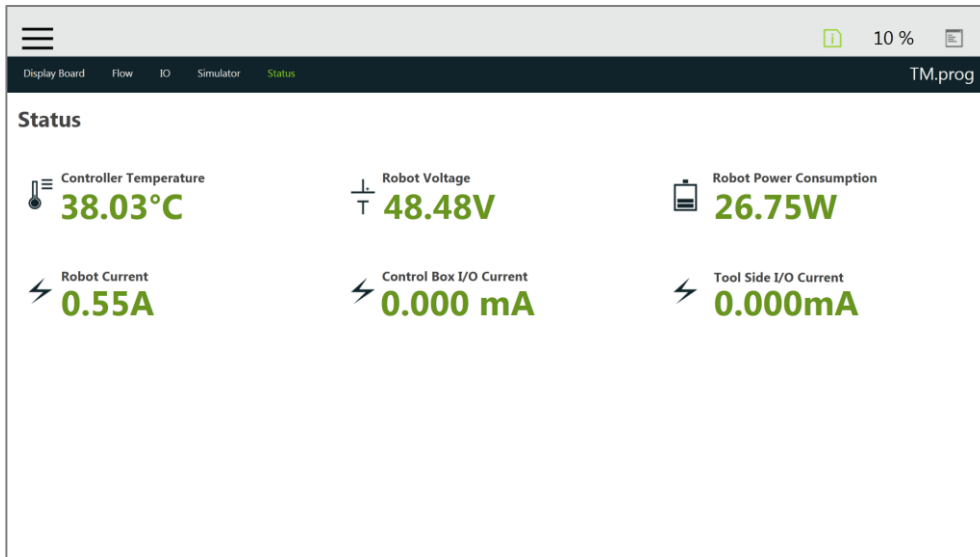

“Status” page

### 5.5 Run Setting

In the “Run Setting”, all executable projects can be viewed. Such as, **Current** displayed on the file represents this project is running currently, **Tested** displayed represents this project can be run in Auto Mode. If the project is to be run in Auto Mode, it must go through the Trial Run process. The running method of Trial Run is performed in Manual Mode. After adjusting the speed, press the M/A Mode Switch Button on the Robot Stick while the project is running, and complete the project with complete Trial Run procedure and ensure the safety while running.





Your\_Project\_Name

Single project icon



## 5.6 Project

Click  in the upper left corner to expand the Function Menu, click the "Project" in the Function Menu to start creating and editing the flow. In the figure below, the top is the Project Editing Toolbar, and the left is the Node Menu, the right sidebar contains System Log and System Function Menu. Click  to expand the "System Log" which is folded on the right. Click  to expand the System Function Menu folded on the right.

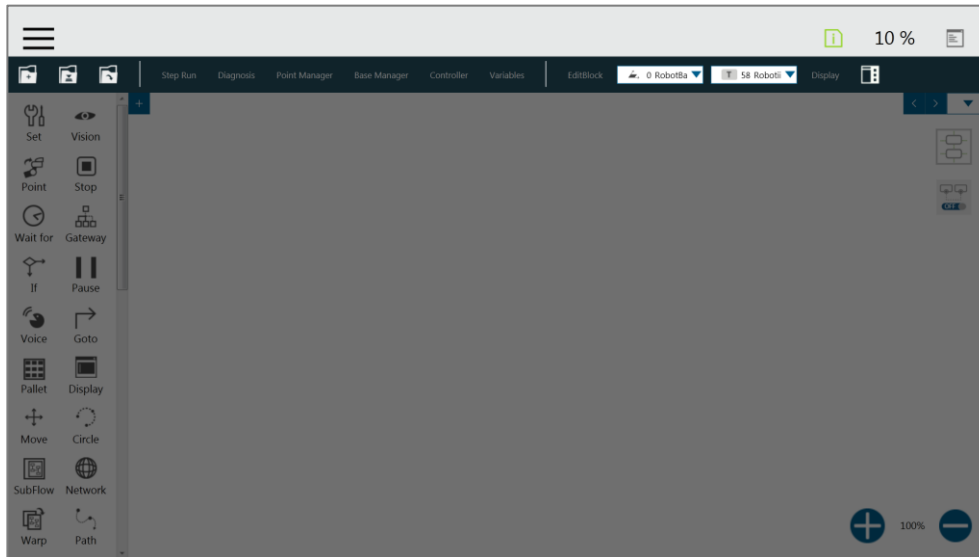

Project Editing Page

### 5.6.1 Project Editing Toolbar

The Project Editing Toolbar is located at the top of the Project Editing Page. From left to right the functions are "Create New Project", "Save Project", "Open Old Project", "Step Run", "Diagnosis", "Point Manager", "Base Manager", "Controller", "Variable", "EditBlock", "Current Base and Base List", "Current Tool and Tool List", "Display Manager".

#### 5.6.1.1 Create New Project

Click  to create new project, the project name can only use English, number and underline (underline symbol is: \_).



#### **IMPORTANT:**



When save the file, if there is a file with the same filename, it will be overwritten, save the file with care to avoid file loss.

### 5.6.1.2 Save File (Project)

Click  to save project, project name can only supports case-sensitive letters (A~Z) & numbers (0~9) & \_ (underline symbol is: \_).

If the previous project is not closed properly, a prompt window will appear when the project is opened. If you select "Yes", the last saved file version will be opened and all subsequent modifications will be discarded. If you select "No", the file will open with the last state before closing, and for the user to perform the file saving operation.

### 5.6.1.3 Open Project

Click  to open existed projects. Click the  mark on the right of filename in the project list to delete the project.



#### **IMPORTANT:**

Please note that deleted projects cannot be restored.

### 5.6.1.4 Step Run

Step Run is used to confirm accuracy of the editing motion, the start running node of Step Run can be Start, Point Node, or the node that is not reversed gray to facilitate the user to evaluate the correctness of the node/motion. Step run can start running the selected node by press and hold the **DOWN** on the screen or the "Plus button" on the Robot Stick. Release the button during press and hold process, the robot will stop operation, and continue to move after press and hold. When the Step Run pane displays "(Node name)\_finish" representing the node running is completed, release **DOWN** or the "Plus button" on the Robot Stick is pressed and hold again to continue running the next node. In the condition of the Step Run window is opened, the FREE Button at the End Module cannot be used to hand guide the robot. At the same time, both the variable system and the decision formula will not operate. When there is a logical branch node (e.g., If Node, Gateway Node) the path of pass or fail can be selected freely to check each decision branch internal motion programming is correct through Step Run.

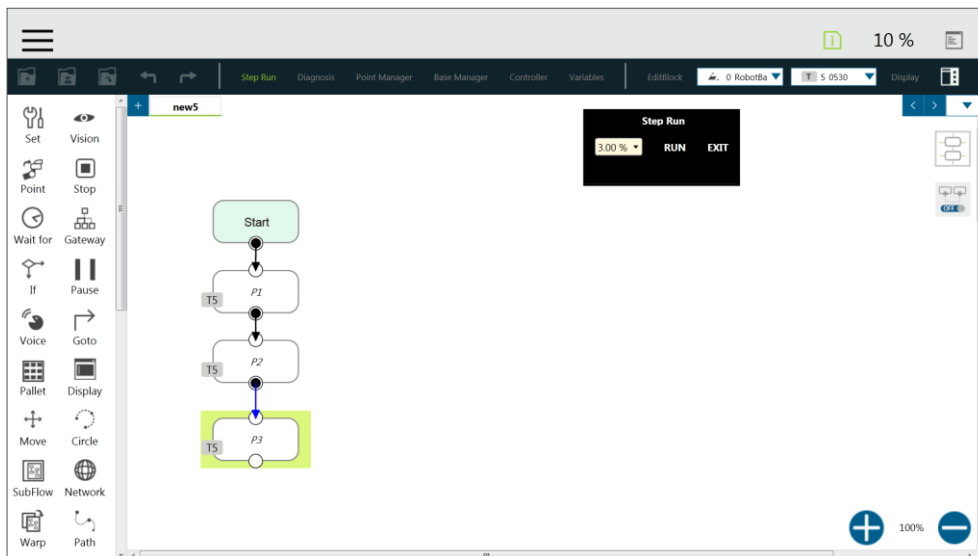



Step Run



**IMPORTANT:**

When using “Step Run” through the Subflow node, click Next to enter Subflow page, or click another node to skip the Subflow steps. Although the variable system will not operate, the Vision Node will run, the Vision Node parameter value and output value can be refreshed through Step Run Vision Node to facilitate subsequent programming and fine tuning. At the same time, since the variable system will not work, the Pallet Node will only run the first point.

5.6.1.5 Point Manager

The Point Manager will list all points and their parameters can be used, including the category of points: General point, fine-tuning point, and dynamic point (for the creation and applicable node of all categories of points, refer to the Point node, F-Point node, and TouchStop node), the reference base to which the point is attached, and the tools used by the point. In the Point Manager,  represents Vision Base,  represents Custom Base. Click the  on the right side of specific point can enter the information page of the point. The point name can be modified in the information page, and find out the reference coordinates, tools and detail coordinates of the point: [X, Y, Z, Rx, Ry, Rz]. Below the information box, there are tools provided to the user to operate the points, from top to bottom, they are: “Controller”, “Overwrite new pose to this point”, “Re-recording on Another Base”, “Save as”, and “Delete This Point”.

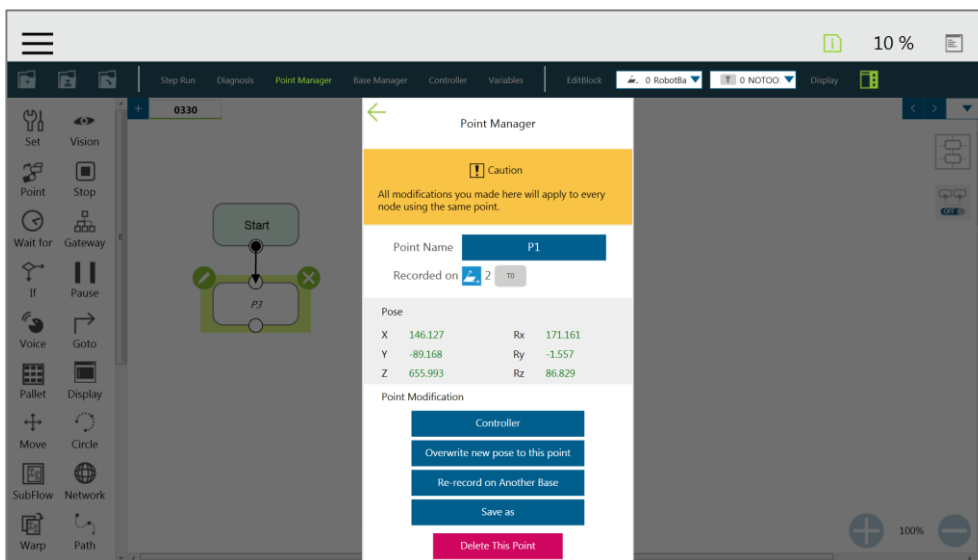
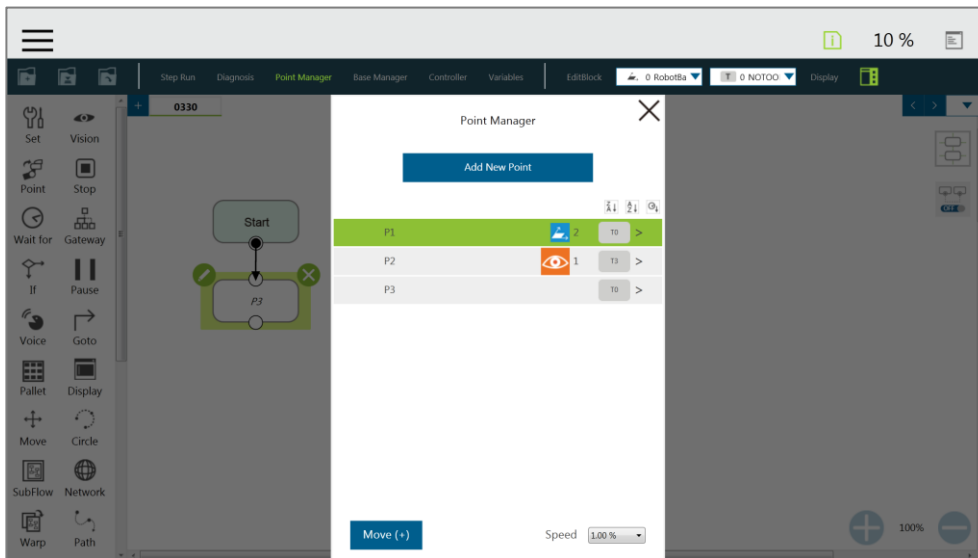

## Point Manager



- Controller: Enable the Controller to operate robot, refer to 5.6.1.7 Controller for the operation method of Controller.
- Overwrite new pose to this point: Write the current robot position and posture at this point and overwrite the original value.
- Re-record on Another Base: re-record this point on another Base, change the reference coordinate.
- Save as: Save as other point with new name.
- Delete This Point: Deleting this point



### IMPORTANT:

The point system and the nodes are mutually independent. The changes made in the Point Manager will be applied to all the nodes that use this point. Before the change, check all the nodes sharing this point again to avoid the occurrence of unintended motion.

### 5.6.1.6 Base Manager

The Base Manager will list all the Bases can be used, the **Current** tag will indicate the Base used by the robot at that time,  represents Vision Base, and  represents Custom Base. Clicking  on the right of the specific base can access the information page of the base. Clicking to set as the current base will change the current reference coordinate used by the robot to this Base. Below the information, there are tools provided for the user to operate the Base. Refer to Chapter 6 “Point and Base” for the definition of Base and 7.2 “Create a Custom Base” for the details how to create the Custom Base.

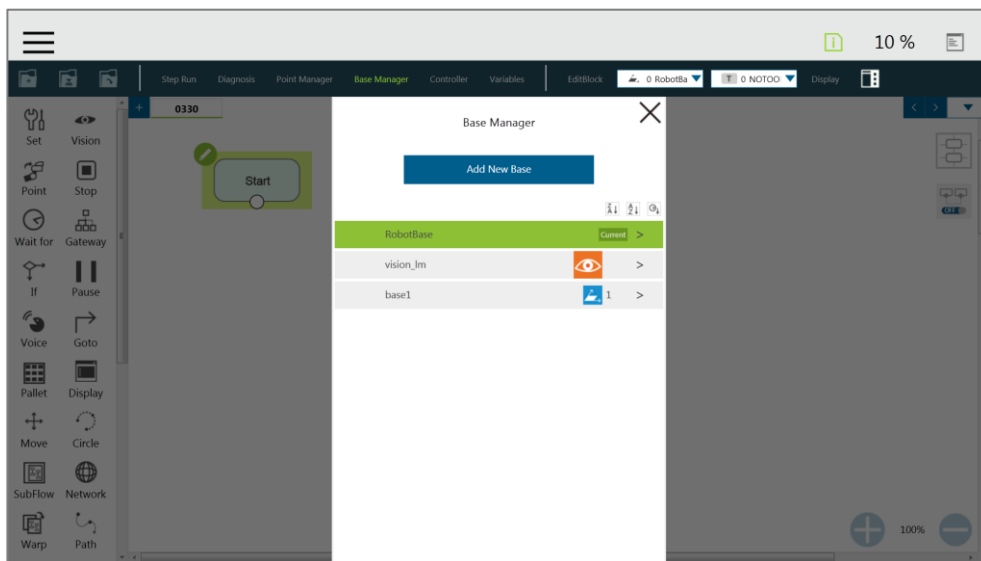

Base Manager

### 5.6.1.7 Controller

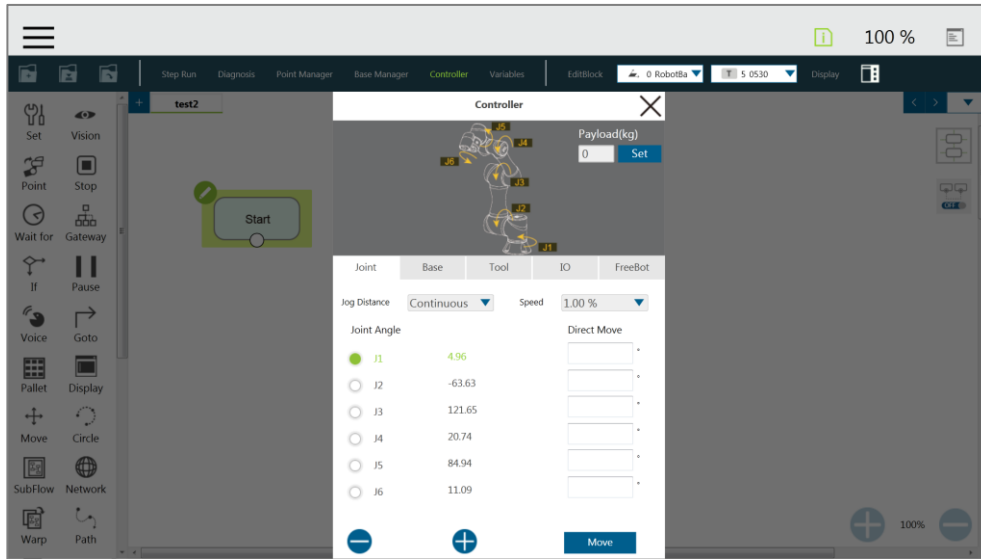

Controller

The controller provides users with direct control to the robot, divided into: motion control, IO control and FreeBot settings. Motion control includes three tabs: "Joint", "Base", "Tool", which correspond respectively to “move according to the joint angle setting”, “move according to the reference base”, and “move according to the tool base”.

Motion Control: After the motion control tab is opened, there are two kinds of motion control methods, single-joint/single-axis movement or moving to a specific target, and the single joint/single-axis movement is used as follows: Click the joint/axis to be moved first, then press **+** or **-** on the left bottom corner, or press the + or - button on the Robot Stick to move the joint/axis in a positive or negative direction. The method of moving to a specific target is: Fill the target to be moved in the textbox on the right, then press and hold the "Move" button below to move the robot to the target position.



**IMPORTANT:**

Base tag is utilized to move to a specified target with respect to the specified Base, and Tool tag is utilized to move to a specified direction with respect to Tool Base.

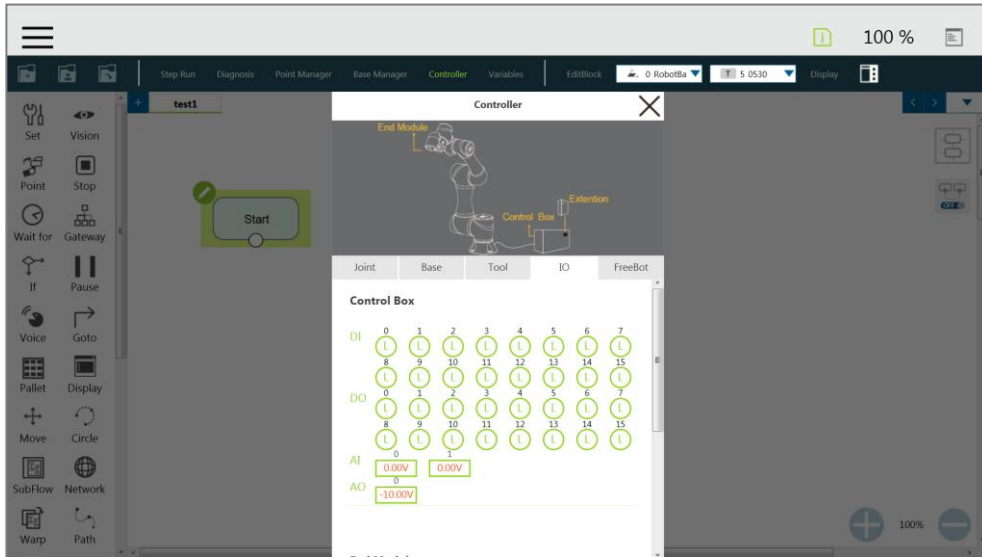

Controller (IO Control)

IO Control: Click "IO" tab to open the IO control page. In the IO control, the output value of each IO can be controlled independently, including Control Box IO, End Module IO, and external expansion IO. The detailed IO specifications and applications can refer to chapter 12.3 "IO"

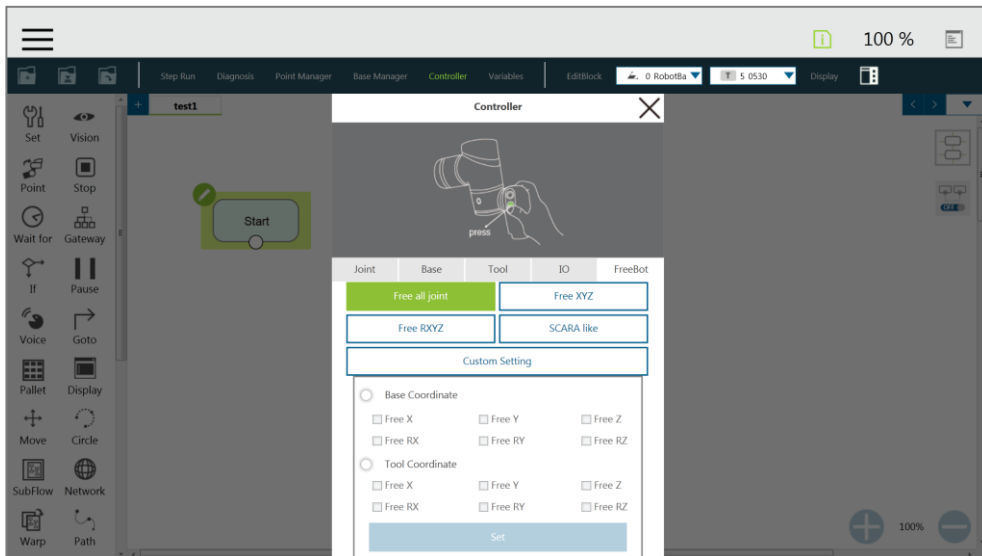

Controller (FreeBot Control)

FreeBot Setting: In the FreeBot Setting, the movement limits of the robot while pressing the FREE Button can be set. The settings are divided into “Free all joints”, “Free XYZ”, “Free RXYZ”, “SCARA like” and “Custom Setting”.

- Free all joint: The user can freely drag the robot through the FREE Button.
- Free XYZ: The user can use the FREE Button to make the robot performing translation-only motion in Robot Base.
- Free RXYZ: The user can use the FREE Button to make the robot performing rotation-only motion in Robot Base.
- SCARA like: The user can use the FREE Button to make the robot performing motion on X, Y, Z, RZ directions of Robot Base, as the traditional SCARA robots. This mode is suitable for teaching simple pick and place jobs, to avoid accidentally causing unnecessary rotation in degrees of freedom when teaching.
- Custom Setting: The user can freely set the degree of freedom to be released and fixed, to facilitate hand guiding.

FreeBot Degree of Freedom Limitation

Press button	Function
Free all joint	Six Degrees of Freedom, the robot end movement and posture change are not restricted
Free XYZ	Three Degrees of Freedom, the robot end can only move XYZ directions.
Free RXYZ	Three Degrees of Freedom, the end can only change its orientation
SCARA	Four Degrees of Freedom (X, Y, Z, RZ)
Custom Setting	Degrees of Freedom to be set by the user.



**IMPORTANT:**

The FreeBot setting is still valid after the controller page is closed. Therefore, if you find that the robot cannot be pulled at a certain degree of freedom, check whether your FreeBot setting is correct.



### 5.6.1.8 Variables List

TMflow has its own variable system that all types, names, and initial values of all variables can be seen in the variable list. The variable types include both single variables and arrays, the new variables can be added through the add variable or add array button above the variable list.



#### **IMPORTANT:**

Please use " " to enclose the string when inputting the string value to avoid being treated as a variable.

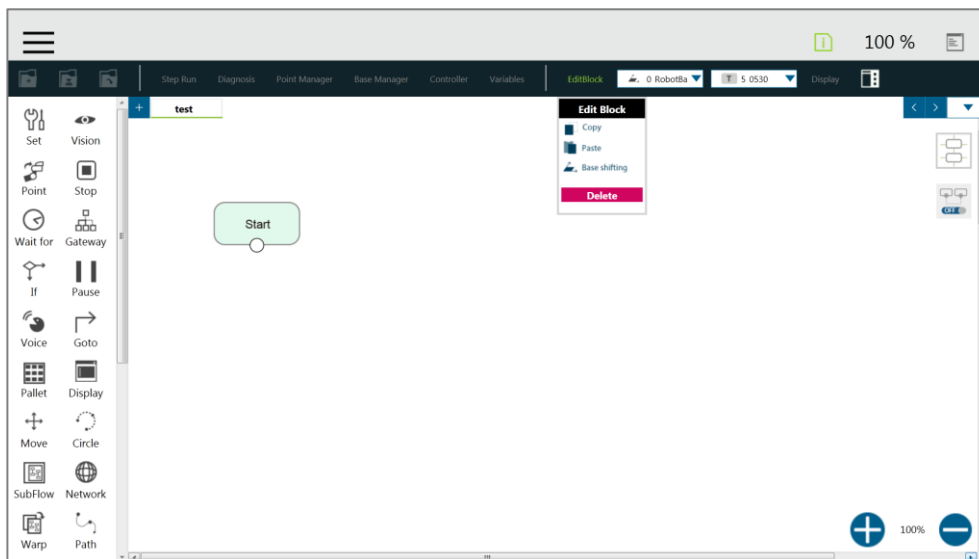

### 5.6.1.9 EditBlock

By extending the EditBlock menu, multiple nodes can be selected, either selection with frame or individual click. The user can then drag and drop all the selections, or click copy and paste icon to copy and paste all nodes, or perform Base Shift for all nodes. All EditBlock related behaviors, including copy-and-paste function can only be performed under the same project.



EditBlock Tool

### 5.6.1.10 Current Base and Base List

The Base list will list all Bases for this project and also indicates the Current Base. In the Base list, the front symbol represents the type of Base, and  represents Vision Base,  represents Custom Base. The Base displayed in the box is the Current Base and can be replaced through clicking the list.



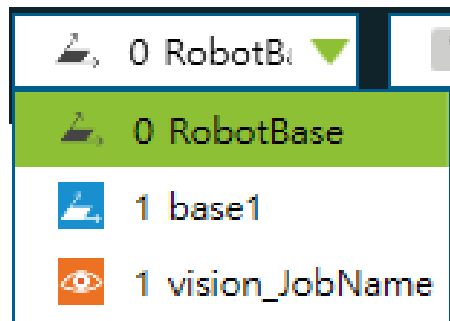

#### **IMPORTANT:**

When the user clicks on the Base list and adds a new point, the point will be recorded on the Current Base.



Base List

### 5.6.1.11 Current TCP and TCP List

The TCP list will list all the TCPs. In the TCP list, the front symbol represents the type of tool,  represents the general TCP, and  represents the built-in TCP list of the hand-eye camera. The TCP displayed in the box is the current TCP, and can be replaced by clicking on the list.



#### **IMPORTANT:**

When the user clicks the TCP list and adds a new point, the point will be recorded with the current TCP.



Tool List

### 5.6.1.12 Display Manager

In the Display Manager, the user can set the variables to be displayed on the display panel and interact with the user when the project is running. Variables are divided into two types: displayed to the user and input by the user. The page where the user may input variable value can be protected with a password, to avoid unauthorized operators intervening with or modifying the robot's motion behaviors by modifying the variables. On the top part of the display management panel, the time period of the refreshing of the display of variables can be specified, and the variable will update the display information according to the set time. Please set the refresh time appropriately to avoid users receiving wrong variable information.

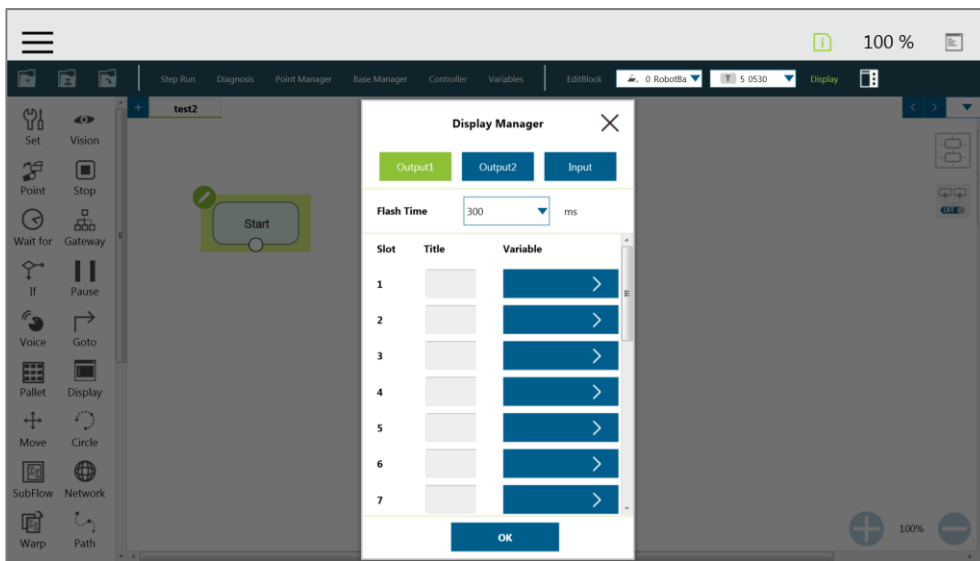



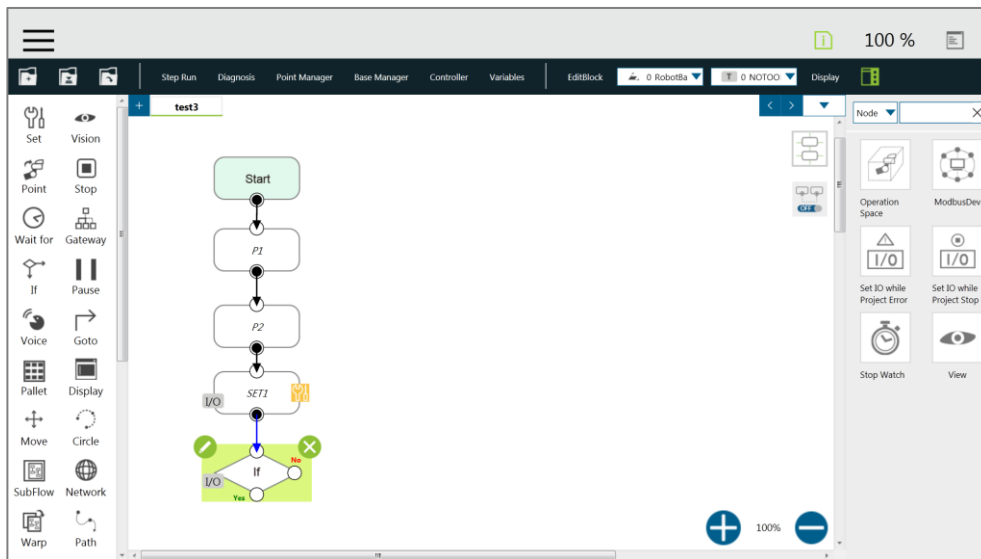

Display Management

## 5.6.2 Node Menu and Flow Editing Area

In the Project Editing Page, the user can create projects. The Node Menu in the left side is a list of nodes that can be used. Drag the icon of each node to the Flow Editing Area to create Flow.



Project Edit

In the lower right corner of the project editing window, there are ,  and display percentage used to adjust the display percentage to facilitate reading. In addition, there is an automatic connection mode switch button, click  to enable automatic connection mode, and click any two nodes in the automatic connection mode, to connect these two nodes according to the order of clicking. If you want to exit the automatic connection mode upon completed programming, click  it again to close the automatic connection mode.

### Note

#### NOTE:

If you use a touch screen for project editing, automatic connection mode will greatly simplify your connection process, dragging between each endpoint is no longer needed, simply enable the automatic connection mode and click on the nodes desired to be connected to connect.

### 5.6.3 Project Function Menu

The Project Function Menu will display the settings and tools related to the project, including search function, Operation Space, ModbusDev, Set IO while Project Error, Set IO while Project Stop, Stop Watch, View.

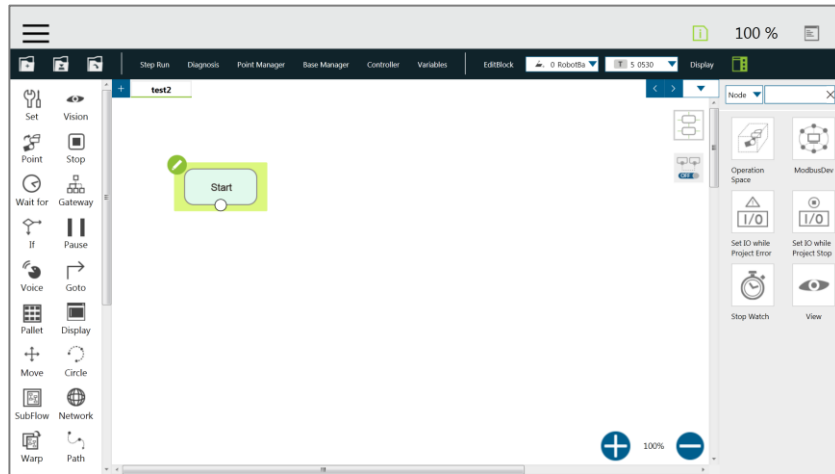

Project Function Menu

#### 5.6.3.1 Search Function

In Search Function, the search can be performed by the node name or variable name. Please click the first search box to determine the search target (searching with node name or variable name used in the node). If searching with a node name, select  , and input the keyword in the search box  behind it. If searching with a variable, select  , and input the variable in the input box. The  in the input box can be clicked to input from the pop up variable list, or input the keyword directly. The search limit condition can be specified below the search box, for the user to narrow the search range so that the user can filter out the desired targets. If you want to jump to a specific search result, click  in front of the item in the result list directly.

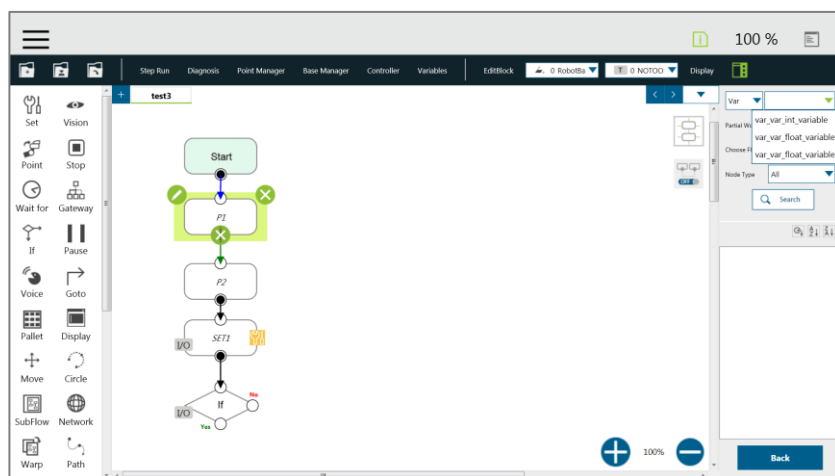

Searching Pane

### 5.6.3.2 Operation Space

The Operation Space can be used to set the operation space configuration of the project. Refer to chapter 15. "Operation Space" for instruction.

### 5.6.3.3 ModbusDev

ModbusDev Tool can be used to set the Modbus Master/Client in the project. Refer to 12.1 "Modbus" for instruction.

### 5.6.3.4 Set IO while Project Error

This tool can set the IO output status when project has an error. Refer to 12.3 "IO" for instruction.

### 5.6.3.5 Set IO while Project Stop

This tool can set the IO output status when project stops. Refer to 12.3 "IO" for instruction.

### 5.6.3.6 Stop Watch

Through the Stop Watch tool, the user can calculate the running time elapsed between two nodes, and plan the motion, manage the production cycles more conveniently through the Stop Watch runtime analysis tool, and optimize time for each flow.

After clicked Stop Watch tool, click "New" can add a Stop Watch. Stop Watch includes four parts, the beginning node, the ending node, records in a specific variable, and the note description, click  in front of Start and End. Then, click the note to be configured to complete the configuration. To save the variable, when Stop Watch is running, the time result obtained while running can be output as the variable to facilitate the user to analyze this parameter. Please select a double type variable in the variable list and fill in the variable box to use this function.

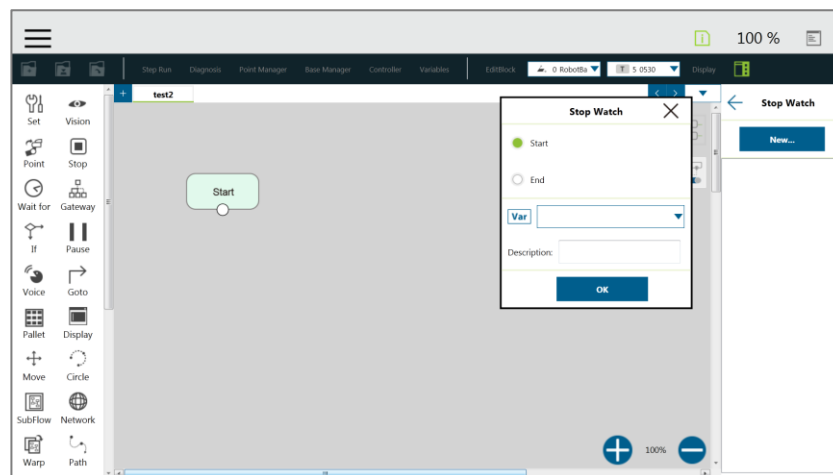

Stop Watch Setting Page

### 5.6.3.7 View

View tool provides the user with a quick view of the current camera's live image, the camera name can be selected in the upper left corner of the image, click  below the image to bring up the camera adjustment parameters.



View Tool Floating Window

### 5.7 Robot Setting

The parameters related to the robot can be set in Robot Setting, the settings from left to right and from top to bottom are: Wizard, Vision Setting, TCP, IO Setting, Safety Setting, Controller, Speech, Gripper Button, Component, Operation Space, Command, Modbus, Posture Setting, and Global Variable.

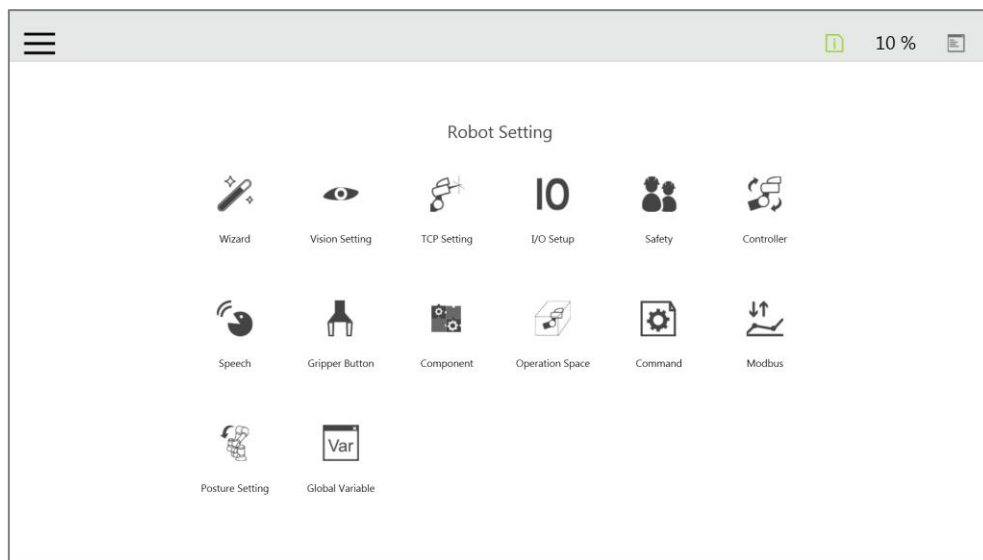

Robot Setting Page

#### 5.7.1 Wizard

The robot setting Wizard will guide the user through robot basic settings step by step, including language, time and date, network setting and speech setting

### 5.7.2 Vision Setting

Vision Setting tool provides the user to modify the camera parameters and manage vision files.

### 5.7.3 TCP

In the TCP setting, the user can create a TCP through FreeBot teaching and Manual-inputting parameters. Please refer to 8.2 TCP Setting for the method of use.

### 5.7.4 IO Setting

In the IO Setting, the default value of the output signal at the time of starting up, and the meaning represented by the self-defined IO can be set.

Using self-defined IO, the user can trigger or read the button on the Robot Stick with external device through the IO port on the Control Box, after the setting is complete, click the "Save" button in the lower right corner to save the setting.

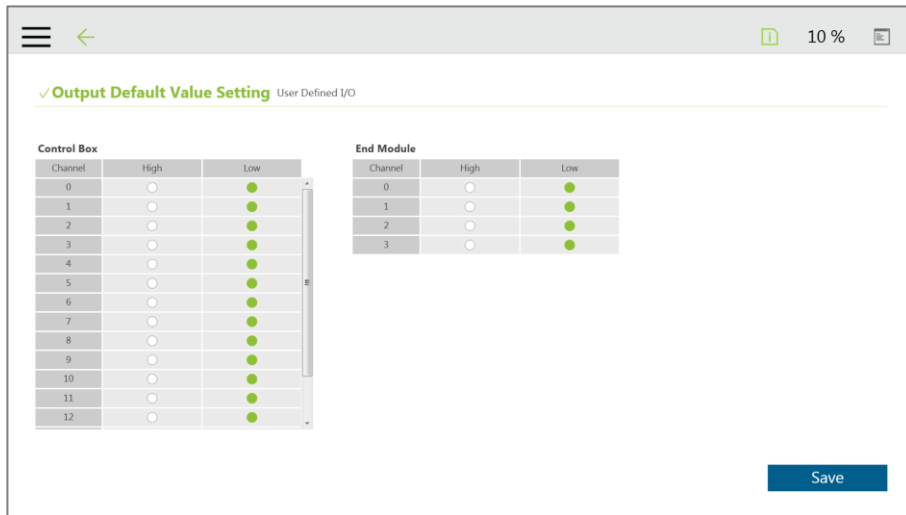

Output Default Value Setting

Control Box Input channel	Meaning	Control Box Output channel	Meaning
9	Stick + button	9	Stick + button
10	Stick - button	10	Stick - button
11	Stick M/A button	11	Stick M/A Mode Switch Button
12	Stick Play button	12	Stick Play Button
13	Stick Stop button	13	Stick Stop Button
		14	System Error Indicator
15	Simulated E-Stop button	15	Simulated E-Stop button

User Defined IO Setting Table



### 5.7.5 Safety Setting

In the Safety Setting, the user can set the safe stop criteria, safeguard port settings, and etc. Refer to Chapter 3 "Safety Settings" for details.

### 5.7.6 Controller

Please refer to 5.6.1.7 "Controller" for the use of controller

### 5.7.7 Speech

In the Speech Setting, the user can set the speech parameters, including the buzzer, speech function and error message broadcasting or not, broadcast language, speed and volume. To use the speech function, connect the speaker to the Control Box.

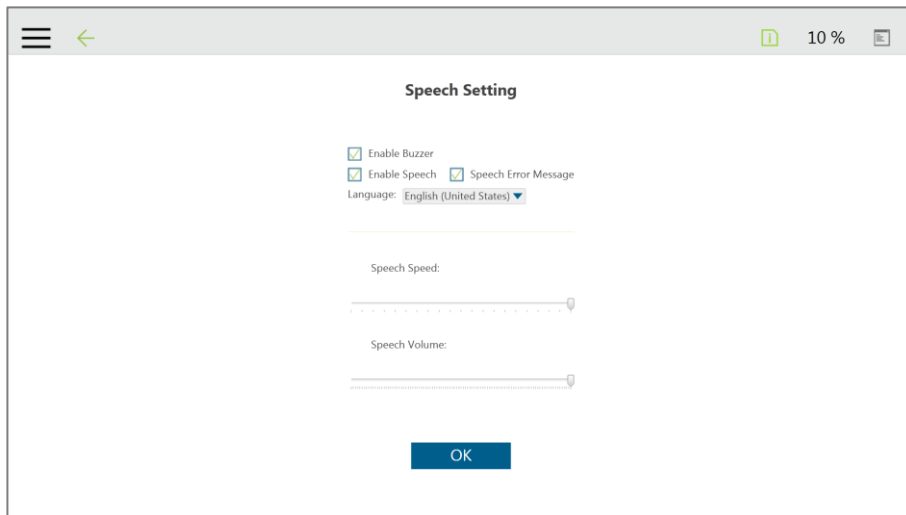

Speech Setting



**CAUTION:**

If using "Speak and Move", the speech will be saved into a buffer and deleted only if the system finishes speaking it. That means, if the Voice is used in a Thread with a quick loop, the buffer size will increase quickly, that the robot might keep speaking without an end.

### 5.7.8 Gripper Button

In the Gripper Button Setting, the user can set the behavior after the GRIPPER Button on the End Modle is pressed. If the gripper used is a general I/O type gripper, click "Grip" to set the IO signal required to close the gripper. Click "Release" to set the IO signal required to open the gripper. If the gripper in use needs to depend on TM Component to operate, select the user-defined component. Please refer to Chapter 13 "Component" Component in regard to the use of TM Component.

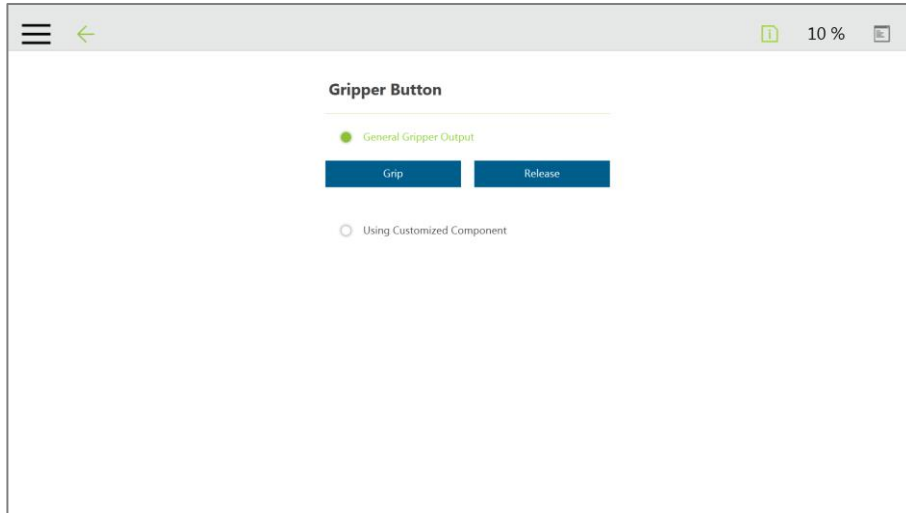

Gripper Button Setting

### 5.7.9 Component

In the Component Settings, the user can select the component to be started from the component list. Please refer to Chapter 13 "Component" for the use of component

### 5.7.10 Operation Space

For the method of using Operation Space, refer to Chapter 15 "Operation Space".

### 5.7.11 Command

In the Command Settings, the user can select and enable the Command from the component list. Please refer to 12.4 "Command" for the use of Command, there are two system default Commands: File and TmComm.

### 5.7.12 Modbus

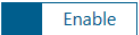
In the Modbus Setting, the user can set the Modbus slave related settings. The system provides a total of two Modbus communication methods: Modbus TCP and Modbus RTU. Click  on the top to open/close the mode. Click the "Code Table" button in the lower left corner to open the Modbus slave encoding definition file..

### 5.7.13 Posture Setting

The Posture Setting provides a convenient tool for the user to quickly move the robot to a commonly used posture, as they are Packing Pose, Normal Pose, and Home Pose from top to bottom respectively. Packing Pose can reduce the space occupied by the robot to facilitate the user to pack and transport the robot. The Normal Pose is the most common work starting posture of the TM robot, and the Home Pose is the posture with all joint rotation angles are 0 degrees.

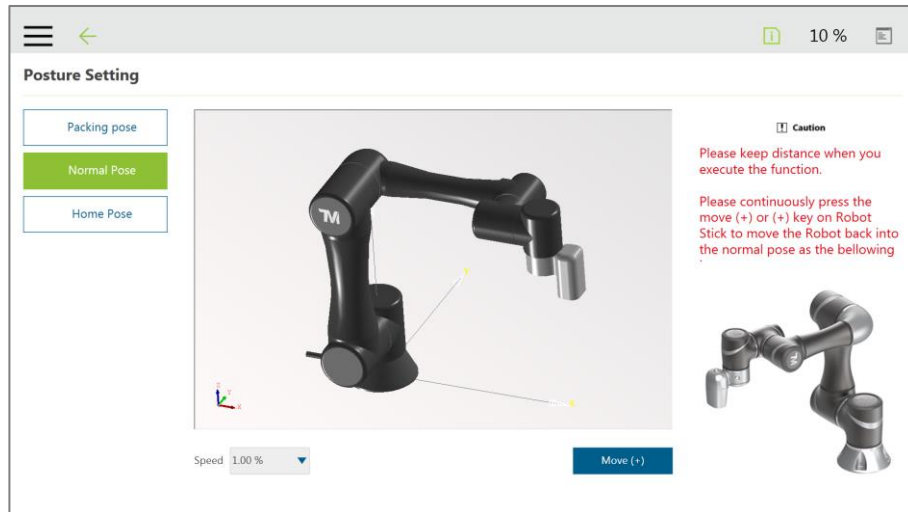

Posture Setting

### 5.7.14 Global Variables

The use of Global Variables is similar to the variable system in the project, but the variables in this system can be used in all projects. Please refer to 10.2.1.1 “Global Variables” for the method of use for Global Variables.

## 5.8 System Setting

The System Setting includes settings related to this software. From the left to right and from the top to bottom they are:

Language, System Update, Group, User Account, Network, Import/Export, Date and Time, Administrator Setting, Set Robot Name, FTP Service, Network Service, Backup/Restore.

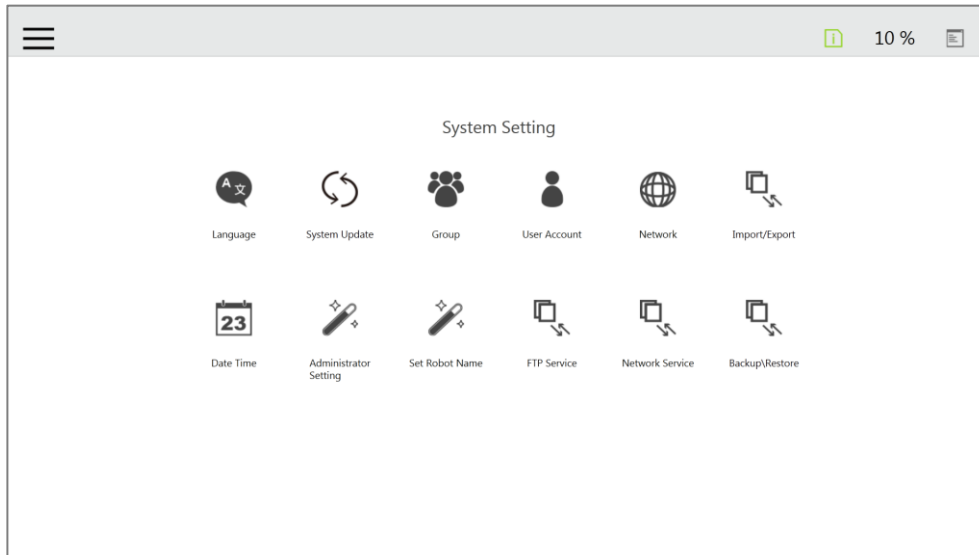

System Setting Page



### **IMPORTANT:**

The System Setting will modify the related settings of the software system. If you are using a remote version, this System Setting will not change the setting in robot's Control Box side system, and it is the System Setting of the Client side system.

### 5.8.1 Language

Please select the system language to be displayed.

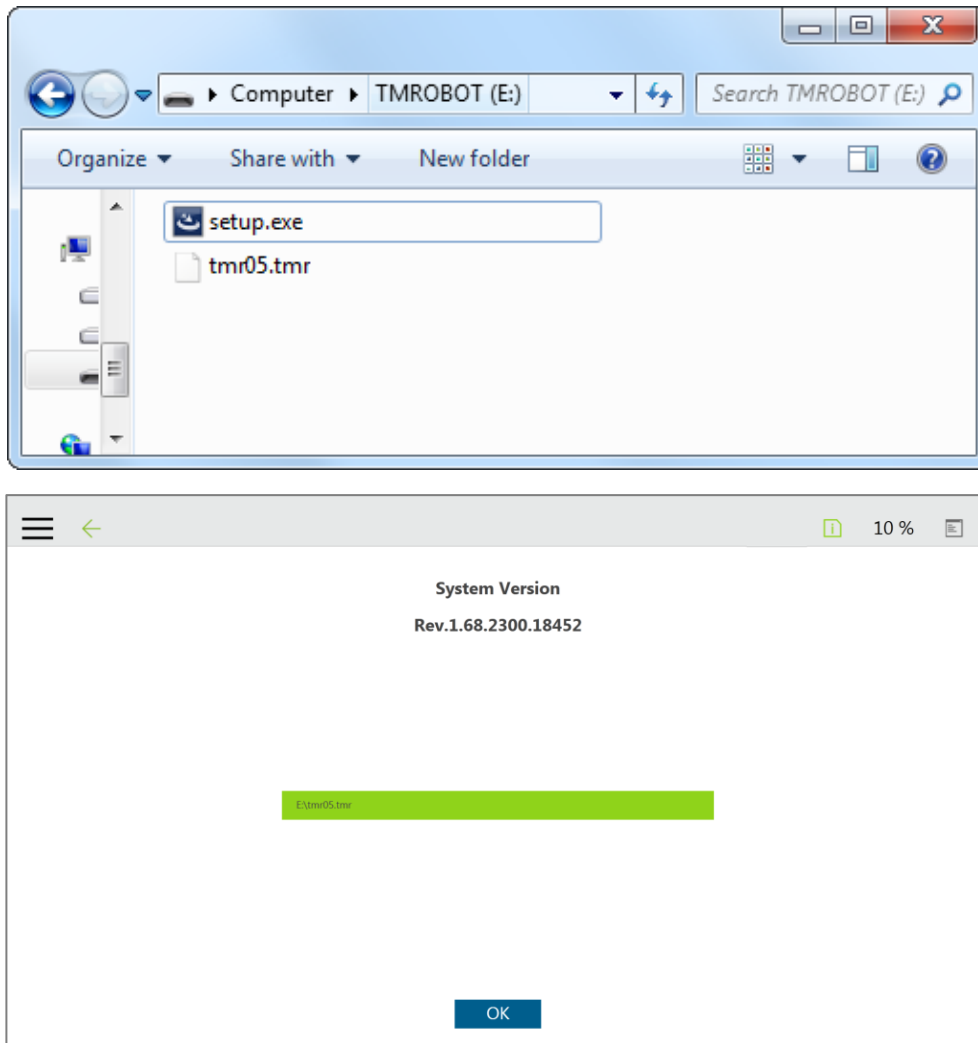

### 5.8.2 System Update

To update the TMflow on the robot, the user needs to download and unzipped the update files from the website of the Company. Then, place all the content generated from the unzipped files into the root directory of the USB flash drive named TMROBOT, as shown below, and plug into the USB port on the Control Box. Please make sure the flash drive name must be TMROBOT. After plug the USB flash drive into the control box. Please click the OK button on the System Update page to start the update.



System Update

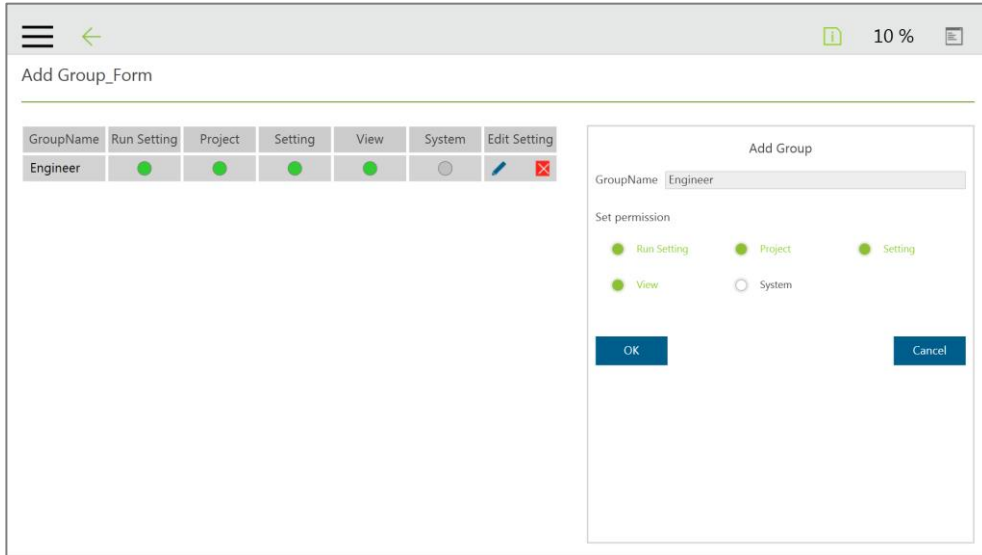

### 5.8.3 Group

In this setting, the user group can be created. Input the Group name from the right pane to create the Group. Select the scope of this Group's permissions when creating, including run setting, project, settings, view, system. Press "OK" after settings are completed to create the Group. After creating the Group, click  to modify information, or click  to delete item.



Group Setting Pane

### 5.8.4 User Account

In this setting, the User Account can be created. Input the User Account and Password from the right pane to create the User Account. It is necessary to select the Group to set the access permission when creating the User Account. After completed creating the User Account, click  to modify information, or click  to delete item.

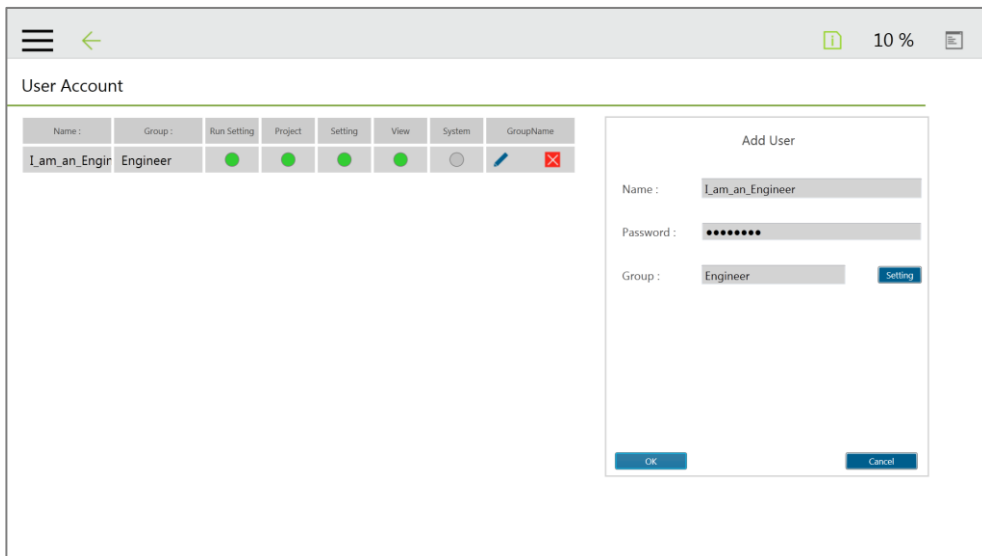

User Account

### 5.8.5 Network Setting

In the Network Setting, the currently enabled connection list will be displayed, click the item to set its parameters. If you choose Get IP from DHCP, the current connection IP will be displayed in reversed gray below

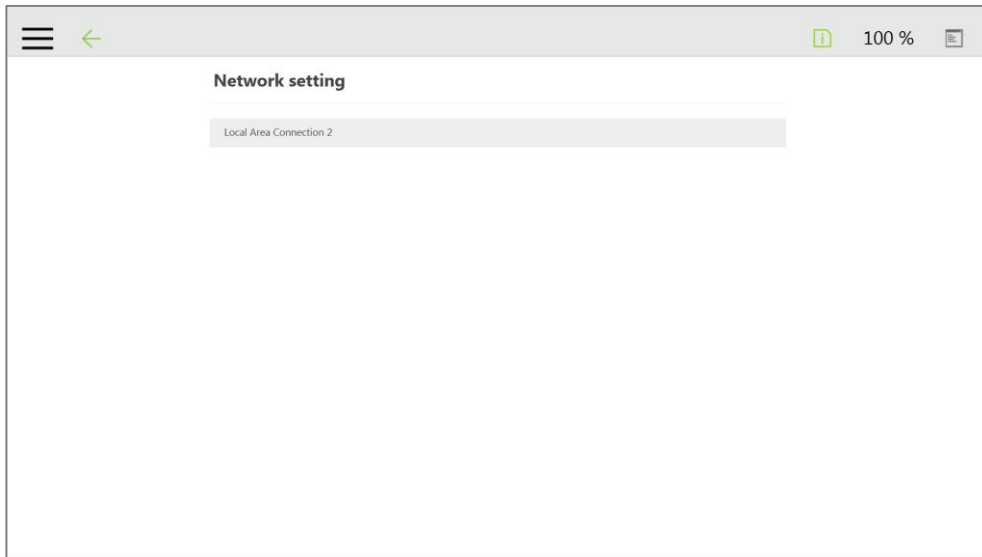

Connection List

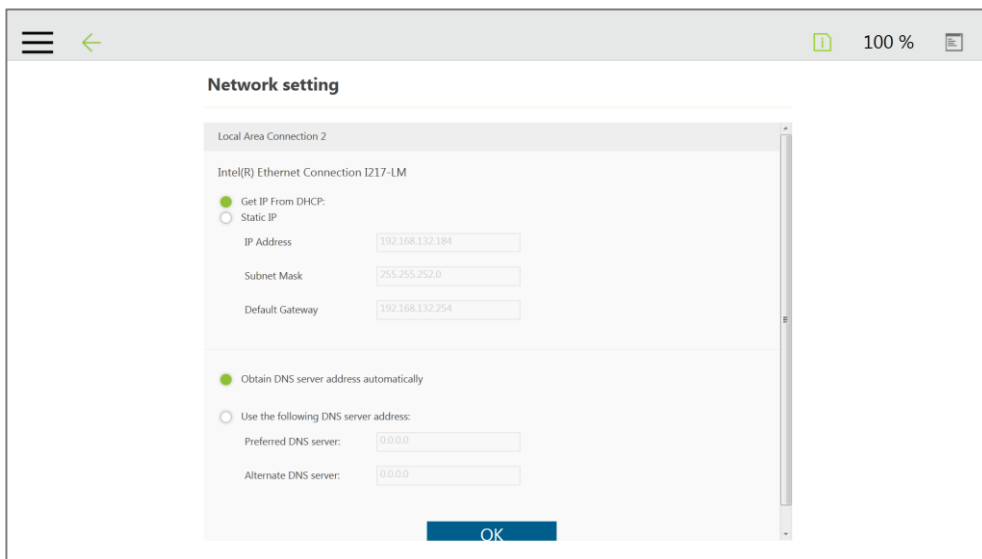

Network Setting

### 5.8.6 Import/Export

In the Import/Export, the user can import items from the flash drive or export items to the flash drive. The name of the flash drive must be TMROBOT. To use the Export function, use the "Export" button in the upper left corner to select Import or Export, then select the desired data from the left menu. Click the item in the list on the left to be added to the list on the right. After completing the new addition, click "Send" at the bottom right to start the Export procedure. To use the Import function, click on the "Import" button in the upper left corner, then select the robot of the data source in the flash drive from the robot list, then select the desired data from the left menu. Click the item in the list on the left to be added to the list on the right. After completing the new addition, click "Send" at the bottom right to start the Import procedure.

### 5.8.7 Date and Time

In the Date and Time, the user can change the time of the operating system that this software runs.

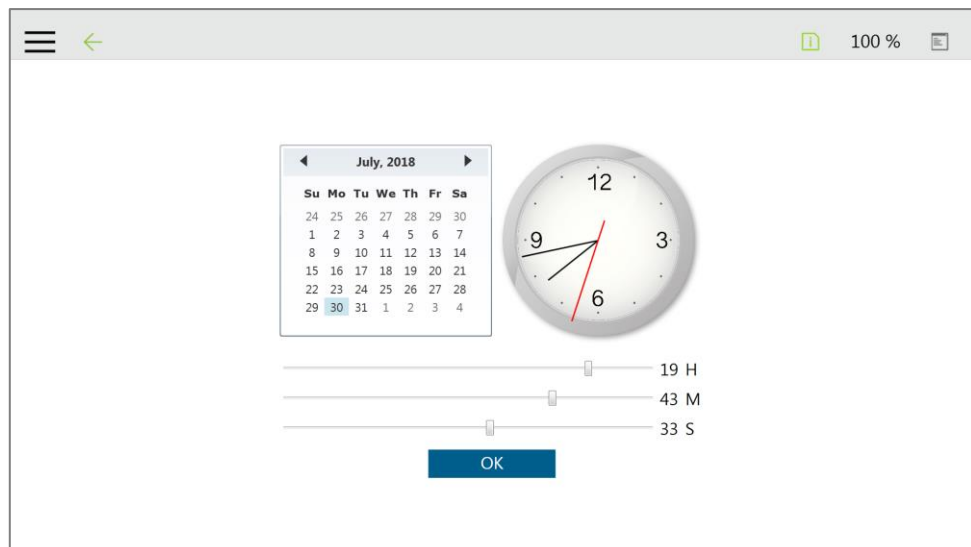



### 5.8.8 Administrator Setting

In the Administrator Setting, the administrator password can be changed/set. The default administrator password is blank. To protect the security of robot use and data, change the administrator password during initial use.

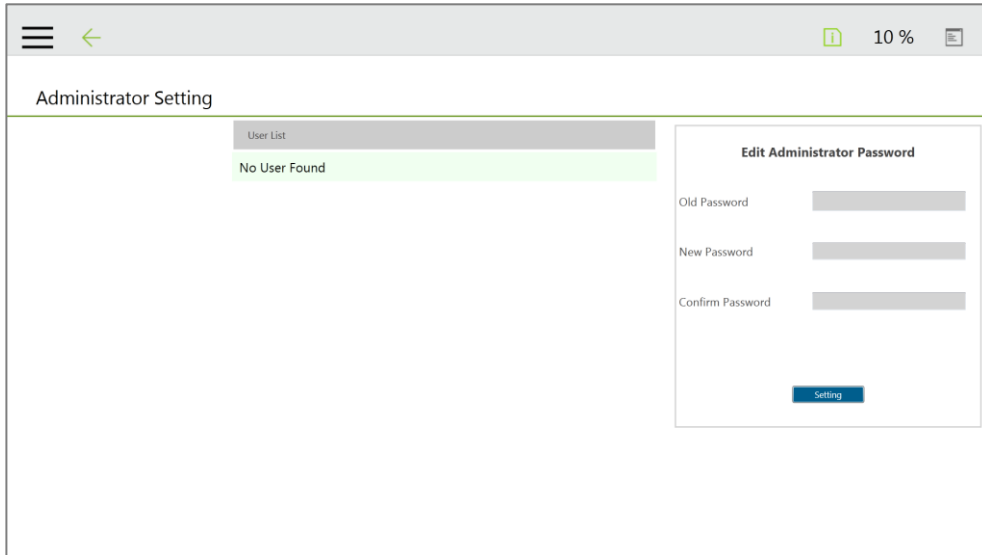

Login Page

### 5.8.9 Network Services

In the Network Services, the user can set the time for uploading data and the shared folder of the target network, and transmit the Log information. In order to ensure that the network connection and the user account password is correct, press the "Test Connection" button first when completed the setting to avoid data loss.

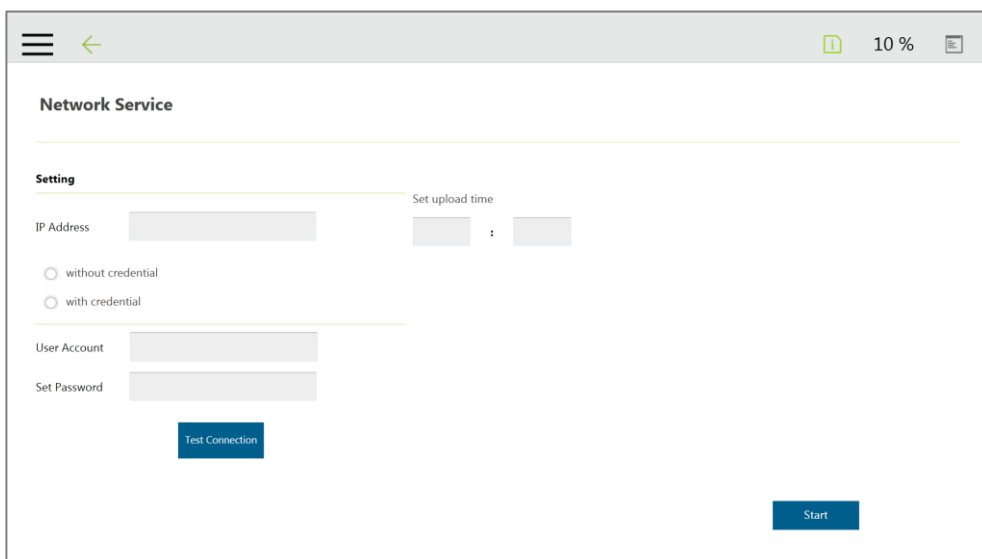

Network Services Setting

### 5.8.10 Backup and Restore

This function provides users to backup and restore the current TMflow version, including projects, TCPs, robot parameters and all other contents. A backup file will be generated by clicking Backup button. After users upgrade the TMflow version, the restore function can be used to restore the previous version and the file content. When executing restore function, it will show a window and display "After restoring the backup file, the current data will be removed. Do you want to restore the backup file? (Yes / No)".

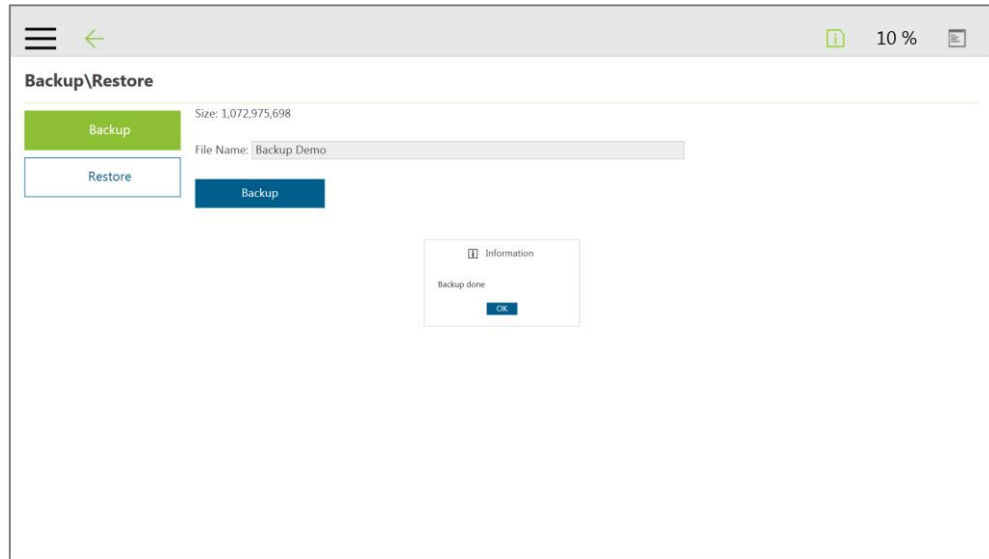

Backup\Restore page



**IMPORTANT:**

The number of backup files is limited to three.

## 6. Point and Base

### 6.1 Overview

In the space, draw three linearly independent lines, select their unit length, direction, to create a new Base. The projection of any point in the space in a three-dimensional space is the position of the point in this Base.

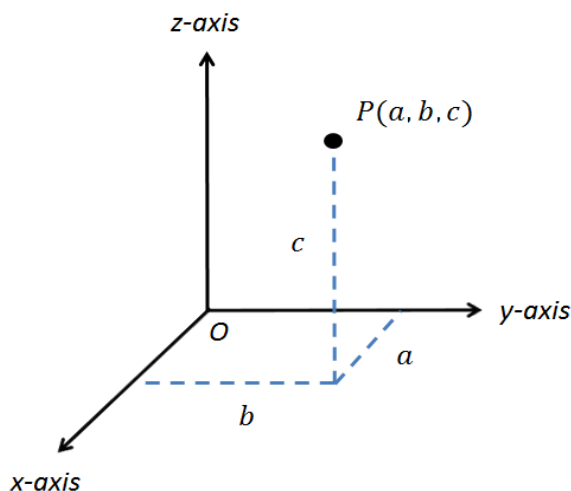

Base value of the Point

To describe a point, in addition to X, Y, Z coordinate positions, it is also necessary to define its direction in the space  $R_x$ ,  $R_y$ ,  $R_z$  to describe the posture of the point in the space.

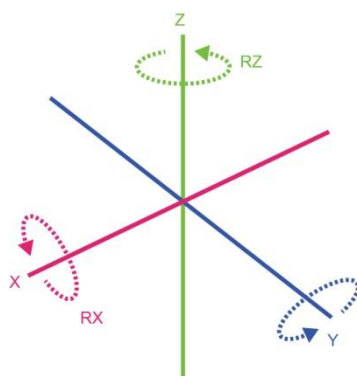

Coordinate axis rotation

The Base is a system that defines the corresponding position and posture of the robot in three-dimensional space. In the TM robot, the Base is divided into four categories: Robot Base, Custom Base, Tool Base, and Vision Base.

This Chapter will introduce the basic direction judgment method for the Base first, and define the physical meaning of the Robot Base, so that the user can understand the Base of robot, and use the controller system to move the robot in the specified Base. Finally, how to convert between different Bases will be introduced, which is for the user to complete the work flow without reprogramming the project in the situation of absolute position changes while relative positions do not change.

## 6.2 Base and Right-hand Rule

### 6.2.1 Right-hand Rule

The Right-hand Rule is a method of determining the direction of the three-dimensional Base. In the system of Base of robot, the right-hand coordinate system can be used to determine the positive direction of the Z-axis, as shown in the illustration, the thumb, index finger, and middle finger represent the right hand coordinate X-axis, Y-axis, and Z-axis respectively, and three fingers are perpendicular to each other. In addition, the Right-hand Rule also determines the positive rotation direction of the coordinate axis in the three-dimensional space, bending finger. The direction pointed by the finger is the positive rotation direction of the coordinate axis.

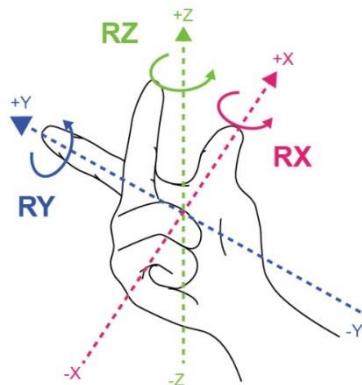

Right-hand Base

### 6.2.2 Types of Base

The Bases defined in the robot are divided into Robot Base, Custom Base, Vision Base and Tool Base according to the purpose. The user can complete the point planning and application in the space using intuitive methods, according to these different base applications.

#### 6.2.2.1 Robot Base

The Robot Base is also called the world coordinates system. In the definition of robot, it is defined as the Base of the robot. When the robot is running, no matter how the position or posture is changed, it will not affect the direction and position of the initial point of the coordinates.

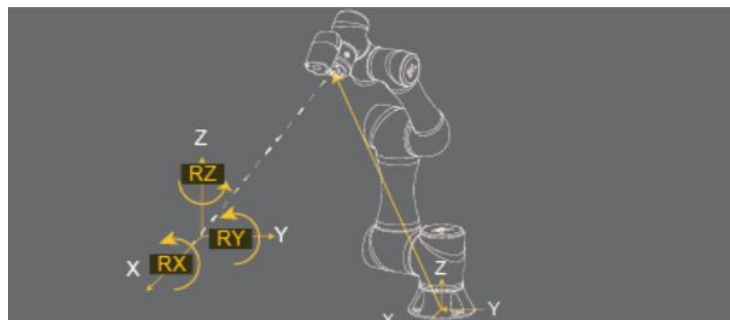

Robot Base

### 6.2.2.2 Vision Base

Vision Base can be further divided into visual servoing positioning and fixed-point positioning. The concept of visual servoing positioning is to approach the object with camera, so the Base is created on the camera. In fixed-point positioning, the relationship between the image coordinates and the robot is known to calculate the positioning object with absolute coordinates and its Base is created on the object.

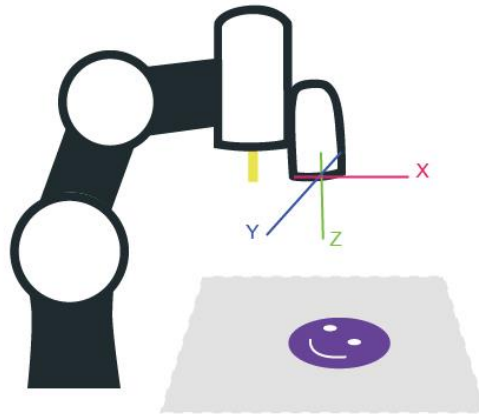

Servoing Vision Base is created on the camera

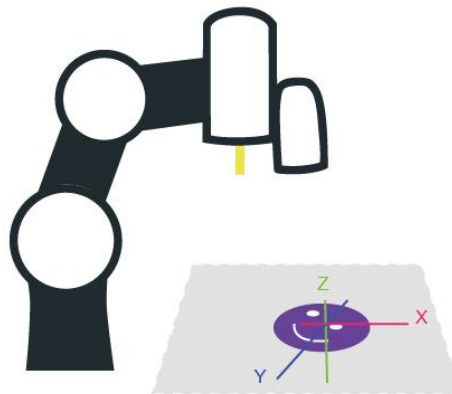

Fix-point Vision Base is created on the object

The robot's vision can be simply built with the Base in parallel to the operation plane, allowing the user to complete assembly, processing, and other related applications on an inclined plane, and can also use the Vision Base to position the robot in the space.

### 6.2.2.3 Custom Base

The Custom Base provides the user with a method for creating the reference Base of the motion node. The user can jog the robot to move to the origin, any point on the X-axis and XY planes of the Base, to create a Custom Base, refer to 7.2 “Create a Custom Base” for the detailed method.

### 6.2.2.4 Tool Base

Tool Base is used to define the position and posture of the robot TCP. Before using the Tool Base, the position and posture of the TCP must be defined ( refer to Chapter 8, “Create End Tool”). If the TCP is not defined, the flange center point will be used as the origin of the Base. In the same project, if the tool is worn out or the tool is changed, you only need to redefine the Tool Base without having to reprogram the flow.

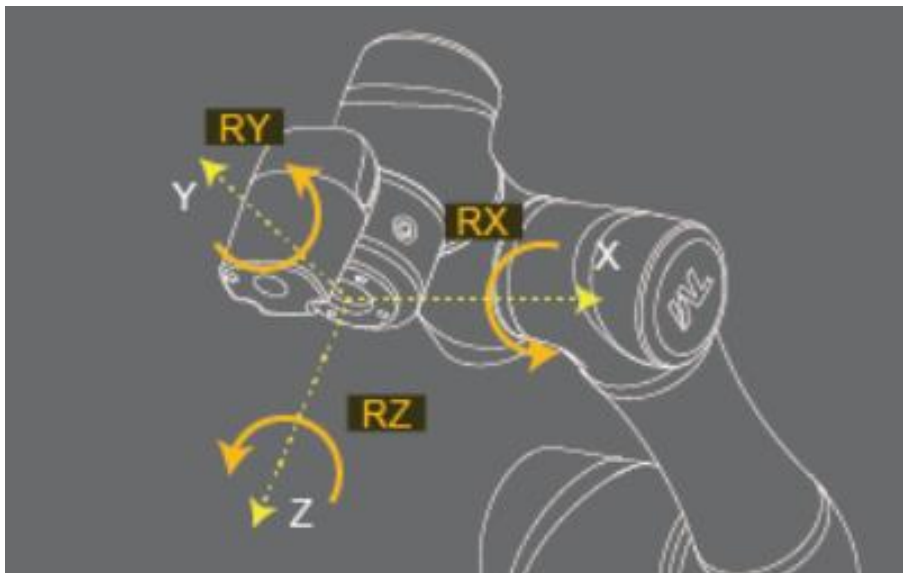

Tool Base

### 6.3 Point Parameter

For the robot-defined Point Parameter, in addition to define the position and posture of each point, it will also regulate the recorded Base of each point and the tools it applies, if the tool it applies is T0, represents No Tool.

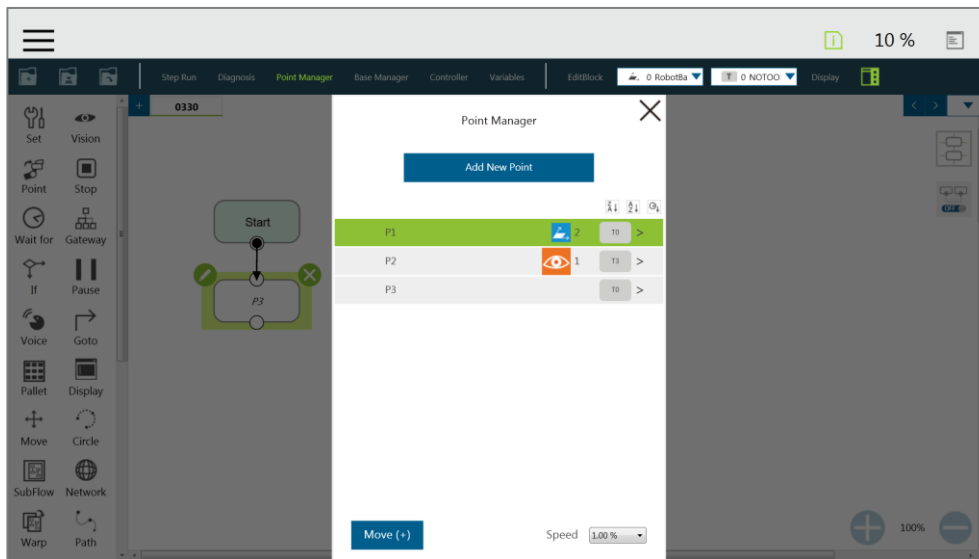

Point Parameter Information

If the user needs to apply different tools on the same project, or perform the same operation on different operation planes, different information can be reassigned to the created point. This section explains the advanced settings in the Point node as an example, this setting can be divided into two categories of Base Shift and Tool Shift to modify the Base of point and the tool applied.

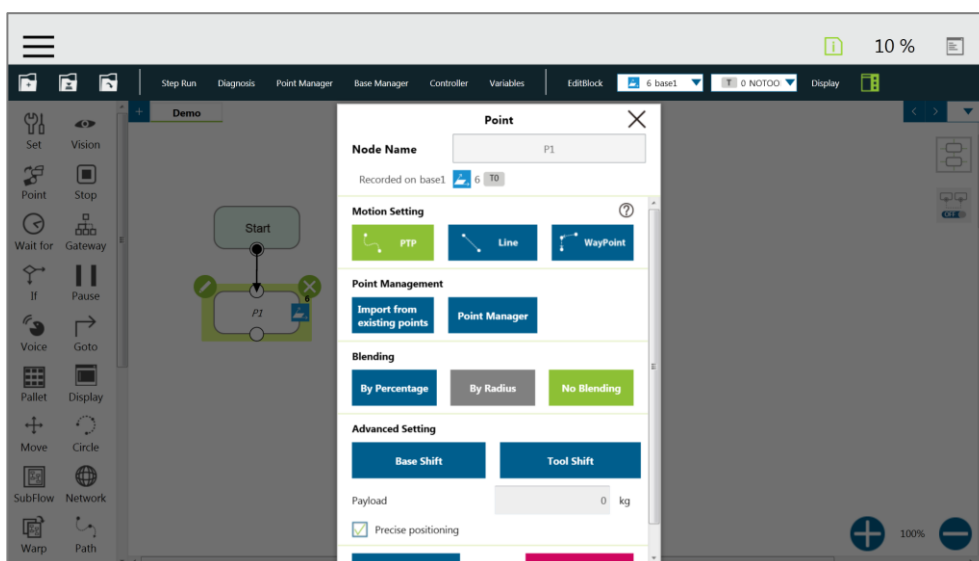

Shift function of Point Node

### 6.3.1 Base Shift

The Base Shift is to transfer the point to another Base without changing the position and posture of its relative Base. In this example, the coordinate is rotated, translated, to convert to another Base. In this new Base, the position and posture of the point related to its reference Base is not changed. In the case of change in absolute position, the relative position is maintained. This function allows the user to complete the same job on different Bases.

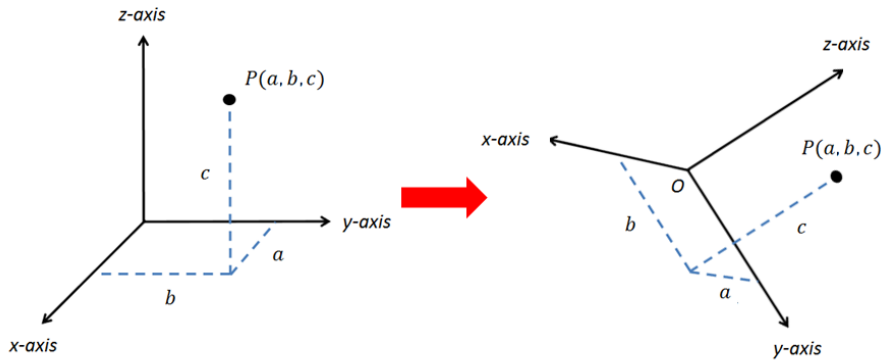

Base Shift Schematic Diagram

Record point P1 on Base 1. At this time, use the Base Shift to record the point to the new base Base 2. This operation will not modify the data of original point, only valid for this set node, and the modified node Base will be presented with pink box.

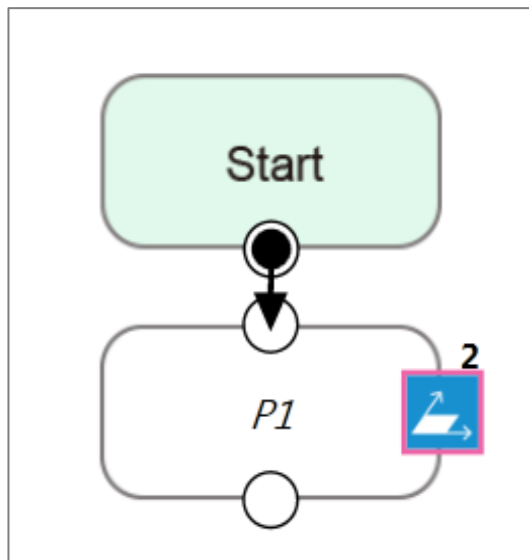

Node with Base Shift



#### IMPORTANT:

This function is different from re-record on another base in the Point Manager. The function of re-record on another base is to present the position and posture of the point with respect to another Base. Therefore, the absolute position of the original point is not changed.



### 6.3.2 Tool Shift

Record point P1 on T1. At this time, use Tool Shift to change the tool T1 applied to P1 to tool T2. In practical applications, this function can be used if the tool is worn out or the same path is completed using different tools. This function is divided into two categories: Keep Pose and Keep Path. The same as the Base Shift, this operation does not modify the data of the origin position, only valid for this set node, and the tool icon of the modified node will rounded with pink borders.

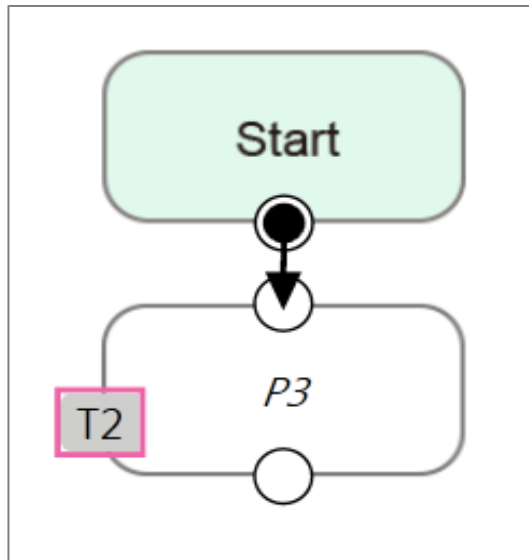

Node with Tool Shift

Keep Pose: If the tool selected when the robot records the path is incorrect, the Keep Pose function of Tool Shift can be used to substitute the correct tool parameters of this node. This setting will not cause changes to the robot's posture and position, that is, it overlaps with the original track when running the project.

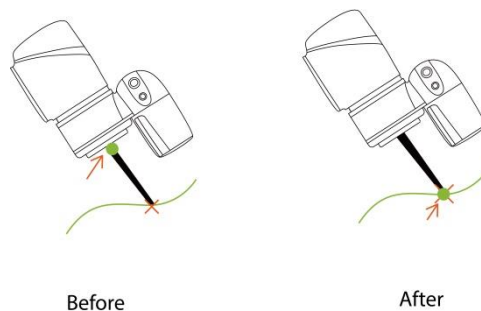

Tool Shift using Keep Pose

Keep Path: The robot will try to make the point recorded with new tool the same as the old tool's point, and further change the robot's posture to conform to the new tool's setting; however, it may not be achieved due to space or robot mechanism limitations.

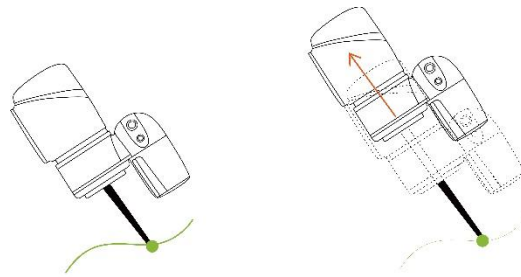

Before

After

Tool shift using Keep Path

## 7. Create Base

### 7.1 Create Vision Base

Vision Base can be generated through Vision Node in the Flow, which can be defined based on the target object or on the camera depending on which method is being chosen (Servoing or Fixed-Point).

### 7.2 Create a Custom Base

Click on the Base Manager above the project editing page. The user can use three points to create a new Base. Since the information of each point is recorded on the Base, only three points need to be redefined when changing the work plane. It is possible to implement the motion on another plane without reprogramming.

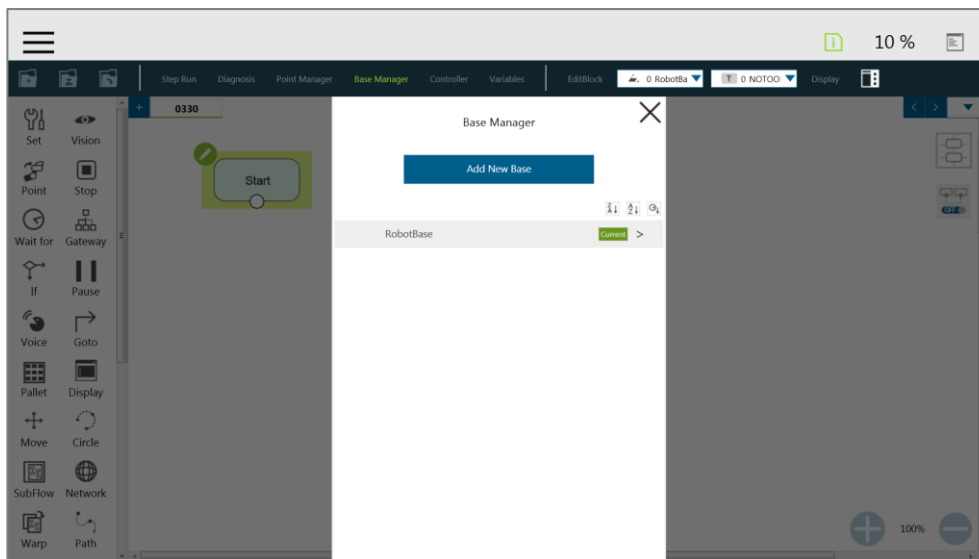

Base Manager

There are three buttons in the center of the three-point Base, from left to right, they are Set the Base Origin, Set any Point on X-axis of the Base, and set the Base on any Point on the Positive X - Positive Y Plane. Refer to 6.2 Base and Right-hand Rule to use the Base correctly.

The user can use the controller button below to enable the controller to operate the robotic arm, or use the FreeBot mode to pull the robotic arm to the target position ("Pointing 0,0,0", "Point on X-axis", "Point on Surface"). Press the corresponding button at this time will record the robot's current position at this point. After the setting is completed, the  in front of the button will disappear. After all three points are set, press "OK" to create the Base.

**NOTE:**  
Build a Base by 3 Points

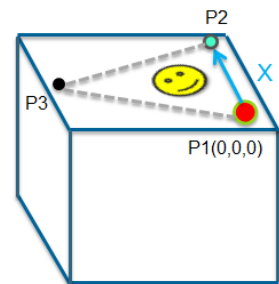
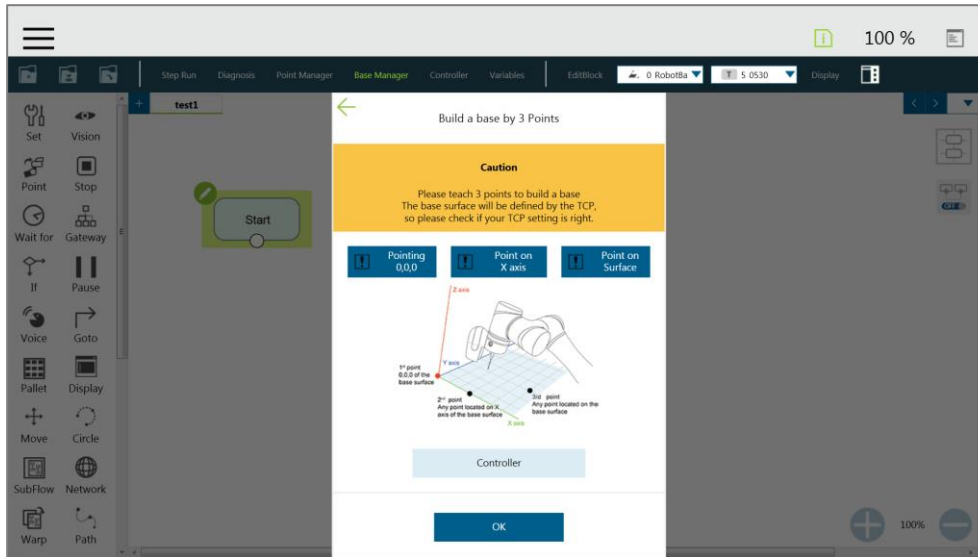

There are 3 buttons representing the 3 points which define a base, i.e. Origin (0,0,0), Point on X-axis, and Point on Surface, refer to 6.2.1 Right-hand Rule.

The user can use the controller button below to enable the controller to operate the robot, or use the FreeBot mode to pull the robot to the target position (Pointing 0,0,0, Point on X-axis, and Point on Surface). Press the corresponding button at this time will record the robot's current position at this point. After the setting is completed, the  in front of the button will disappear; after all three points are set, press "OK" to create the base. This point is TCP point.

## 7.3 Create New Base Node

### 7.3.1 Create a New Base by Two Vision Bases

Drag the New Base Node from the left side. After clicked Edit on the upper left of the node, the user can select to use two Vision Bases to create a new Base, or use three dynamic points to create a new Base.

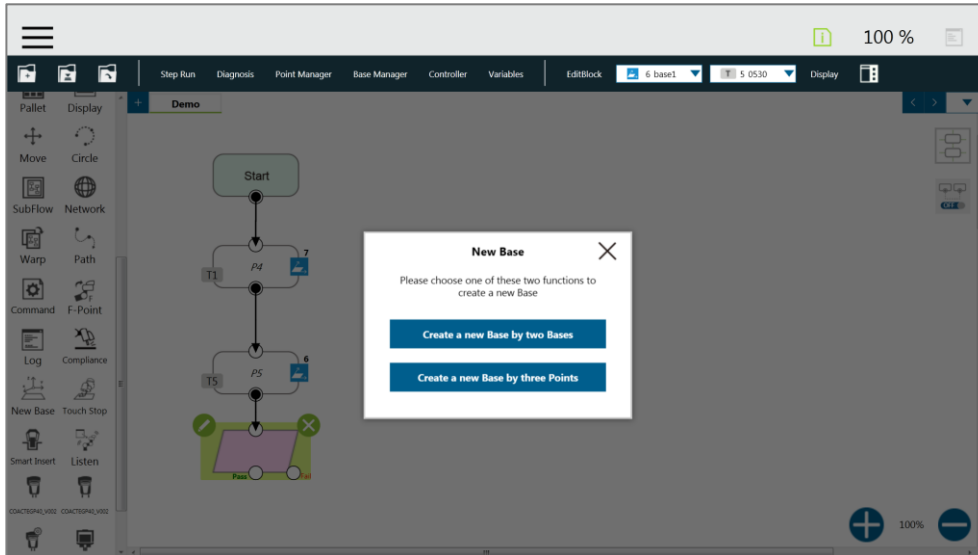

New Base Node

Click to create a new Base with two existed Bases, will open a new page. The user can select two created Vision Bases. The distance between two Bases will be calculated automatically according to selected Base parameters. During the project running, after the distance between two Bases is updated, if the calculated distance falls within the tolerance range set by the user, a new Base will be created by calling the function. If error occurs and it goes out of range, the program will run through the Fail path for this node, that is, the Base cannot be created.

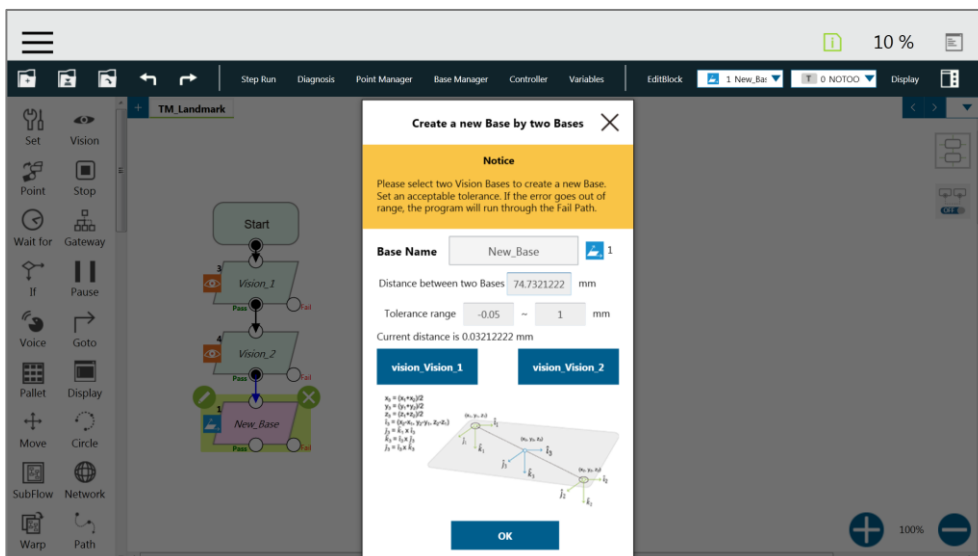

Create a new Base by two Vision Bases

### 7.3.2 Create a New Base by Three Dynamic Points

Clicking on “create a new Base with three points” will pop up a new page. This function can only use dynamic point to create a Base and must work with TouchStop Node to create a dynamic point, and finally complete creating the Base with implementing three times of the TouchStop Node. The 1st point determines the Base origin, the 2nd point determines the X-axis of the reference surface, and the 3rd point determines the orientation of the reference surface. For detailed application methods, refer to 7.3 "Create New Base Node".

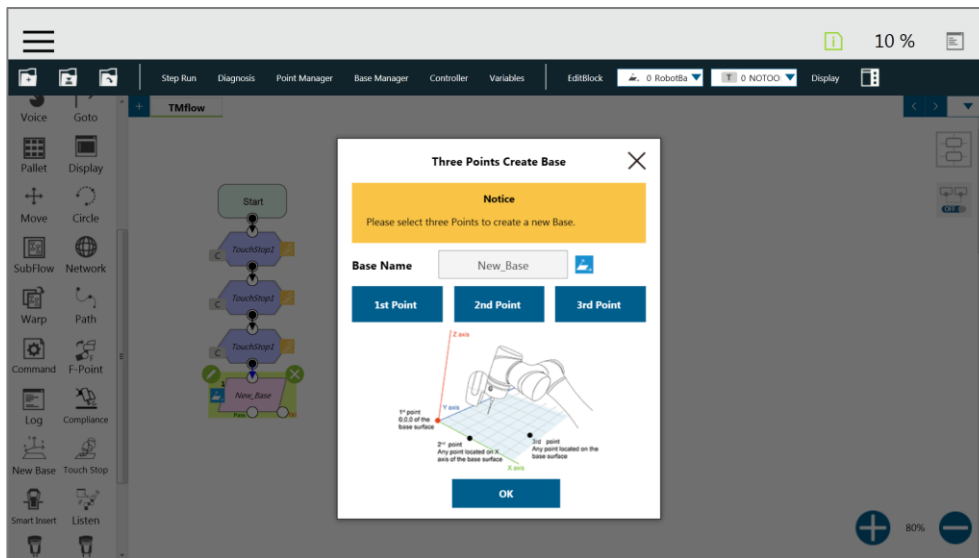

Create a new Base by three Dynamic Points

## 8. Create End Tool

### 8.1 Overview

This Chapter will introduce the settings of TCP (Tool Center Point). The TCP is the reference point for tool interaction with the workpiece. The TCP includes six parameters: X Coordinates, Y Coordinates, Z Coordinates, Rx Coordinates, Ry Coordinates, Rz Coordinates. Description is referenced from the center coordinates of the flangeCustom Base. The TCP will be attached to the end of the robot, and move with the center coordinates of the flange.

On the robot, apart from the position and orientation reference values of the six elements, the tool weights and the inertia values can also be inputted to compensate the performance during the operation to avoid misread the effect of the tool on the robot as an external force. The TCP Setting can be accessed from the Robot Setting page.

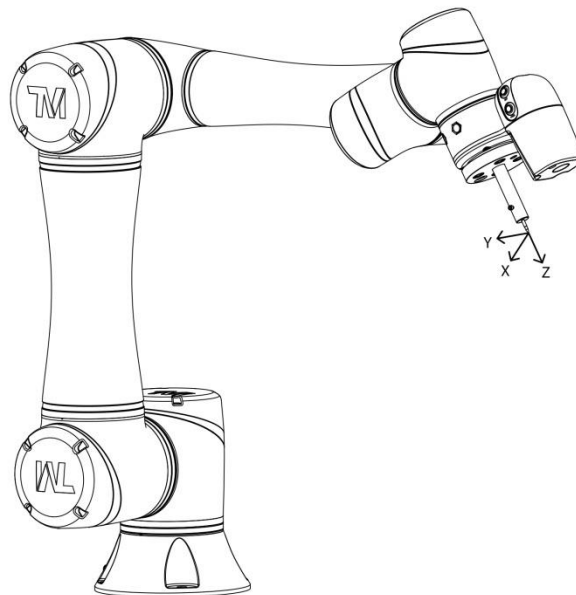

TCP Definition

## 8.2 TCP Setting

This Section describes how to get parameters of TCP from "Teaching", "Manual Input or choose from Saved File".

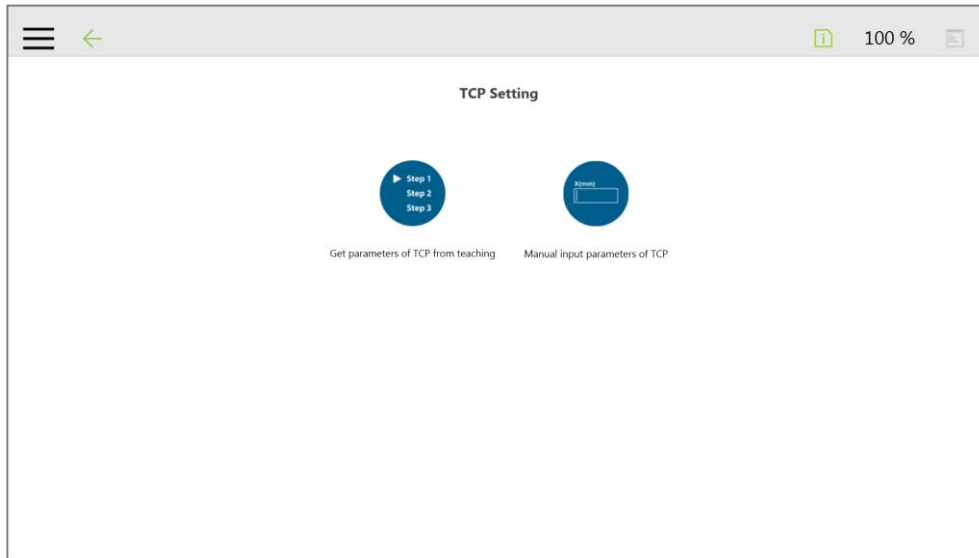

TCP Setting Items

### 8.2.1 Create Parameters of TCP with Hand Guidance Teaching

The principle of creating the TCP by teaching is to teach the robot to reach the same point in the space through different posture, to calculate the position of TCP relative to the robot end flange automatically. The Calibration Pin Set sold by the Company or custom made calibration tool can be used to calibrate the fixed calibration point in the space during teaching process. The number of calibrations varies depending on the user's operation method and accuracy requirements. The number of teachings on the TCP is at least 4 times.

The process of creating a TCP by teaching is shown as follows.

1. Setting the times of calibration and quality of tools
2. The position of the TCP is clearly marked on the tool. In this example, the tool is a Calibration Pin Set, and the TCP is located at the tip of the needle.



3. Fix the Calibration Needle on a solid surface.



Teaching Screen

4. Then align the end of tool to the calibration point by teaching, and follow by clicking the record on the screen.



The robot posture needs to change during teaching

5. Repeat this action until completed and the TCP numerical results and error values are displayed. After confirming there is no mistake, input the tool name to save the file, and set it as the current tool for the robot.
6. After completed teaching, the positioning result will be displayed. It is recommended to calibrate this value equal or less than 0.3 to ensure accuracy.

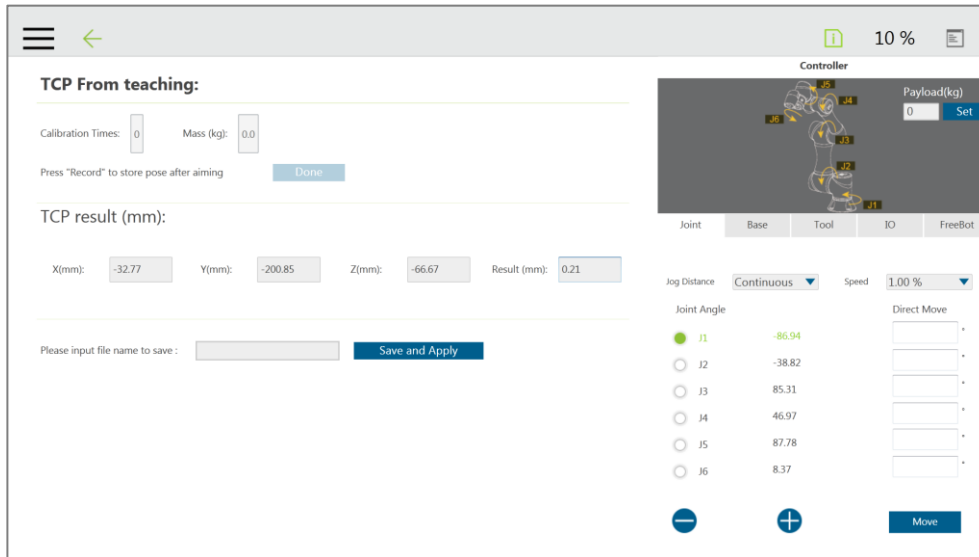

Result of Teaching TCP

**IMPORTANT**

**IMPORTANT:**

In addition to the user's human errors and the number of calibrations, the error of establishing a TCP by teaching is also related to the selected teaching posture. The selection principle of posture is that the more the changes of each joint the better. Between each teaching point, it is necessary to ensure that 1 to 6 joints are rotated to achieve the best calibration result.

**Note**

**NOTE:**

When using the Calibration Pin Set to teach TCP, the controller can be used to fine-tune the moving robot. Between each teaching point, it is still necessary to ensure that 1 to 6 joints are rotated.

7. The calibration result can be saved for future use.

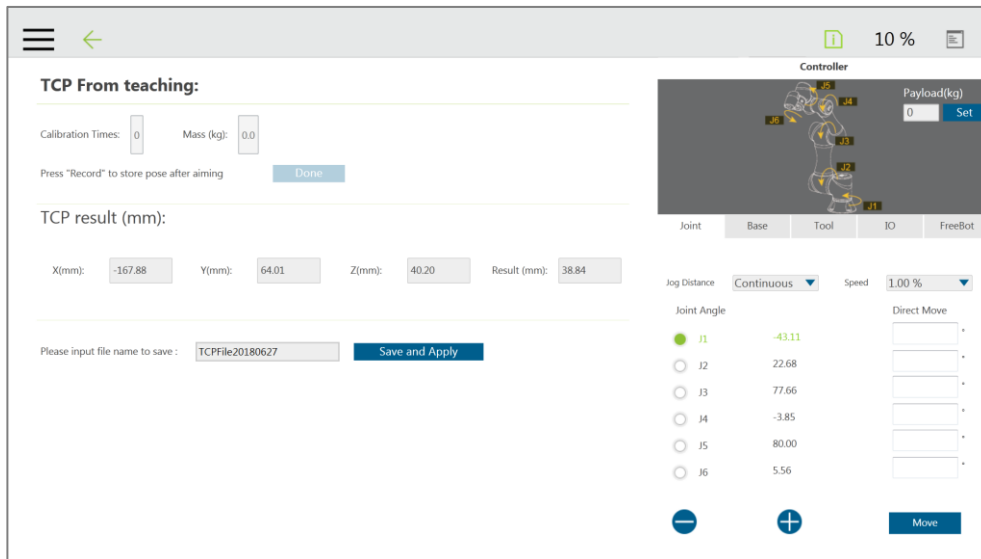

Save Teaching Result

8.2.2 Create Tool Center Point by Input Parameters

If the user clearly knows the TCP relative to the position of robot end flange, the coordinate parameters can be inputted manually, and after the input is completed, click "Save as" to create a new TCP data. To modify the TCP parameter value, click "Open" button to select the item to be modified from the list, and after the modification is completed, click "Apply" button in the lower right corner to save the changes and set this TCP to the current TCP to be used by the robotic arm. In this interface, all TCP data on the robotic arm can be managed, click "Open" button to open the TCP list of the robot. Click  behind the item to delete the TCP data.

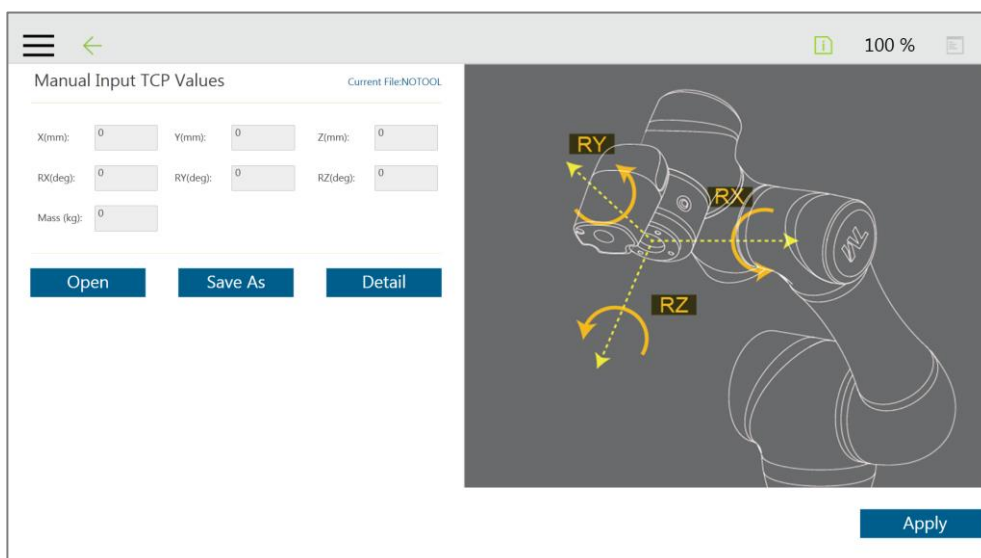

Manual input parameters of TCP page

### 8.3 End Tool Base

Please refer to the following figure for the definition of Tool Base.

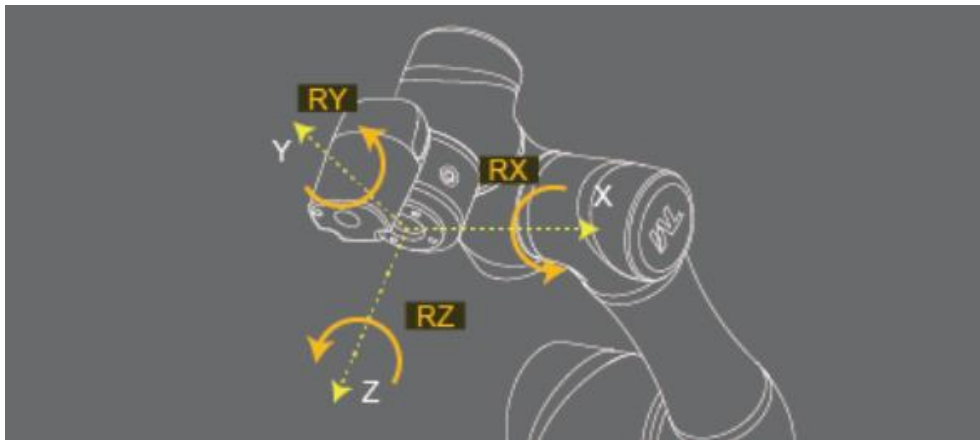

Tool Base

## 9. Motion Programming

### 9.1 Overview

This chapter will introduce the robot's commonly used motion nodes, describe its basic features and motion modes, and let the user understand how the robot will move after executing the relevant settings. This chapter will first introduce the robot motion mode, and explain what is blending, and then perform basic explanations and examples for the relevant motion nodes and robot arranging in groups.

TM Robot motion type

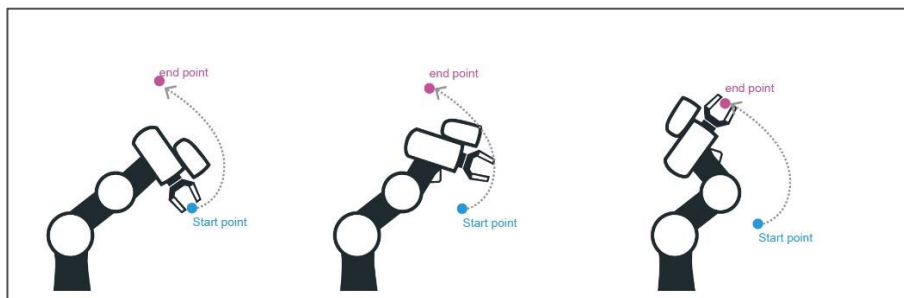

PTP

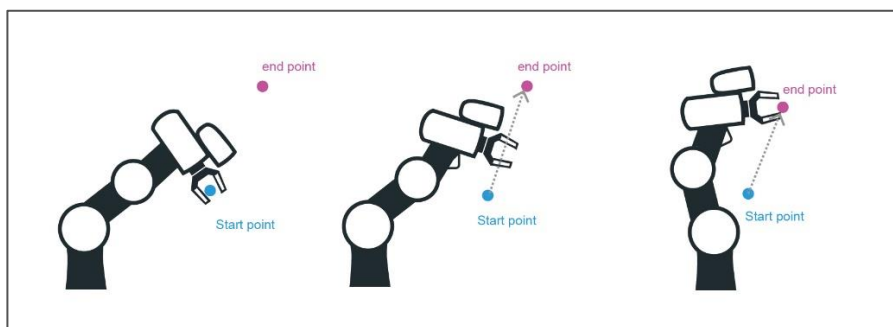

Line

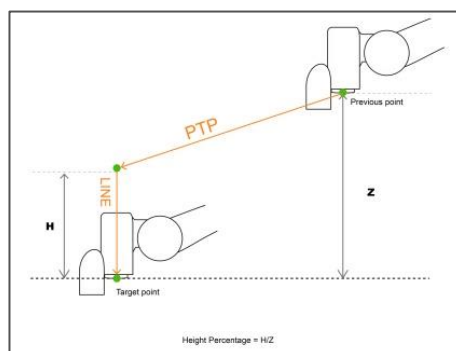

WayPoint

**PTP (Point to Point):** The robot moves to the target point along the closest path of the joint angle space

**Line:** The tool moves in a straight line at the specified speed

**WayPoint:** The tool performs two-stage path movement at the set Z-axis height, and it is often used for the applications of pick and place objects.

## 9.2 Point to Point (PTP)

### 9.2.1 PTP is the Fastest Way to Move

The PTP mode determines the robot's motion by calculating the angular variation of each axis, and is not limited by the singular point. If the robot's motion is not limited, it is recommended to select PTP movement.



#### **IMPORTANT:**

Singular Point can be briefly described as 1. Decrease in the degree of freedom of the robotic arm, resulting in the inability to achieve certain motion. 2. The angular velocity of specific joint approaches infinity, resulting in loss of control of the robotic arm. 3. Exceeding the limit position of the internal operable range (robot working space) or calculation error of the mathematical model. Please refer to "Safety Manual" for details.

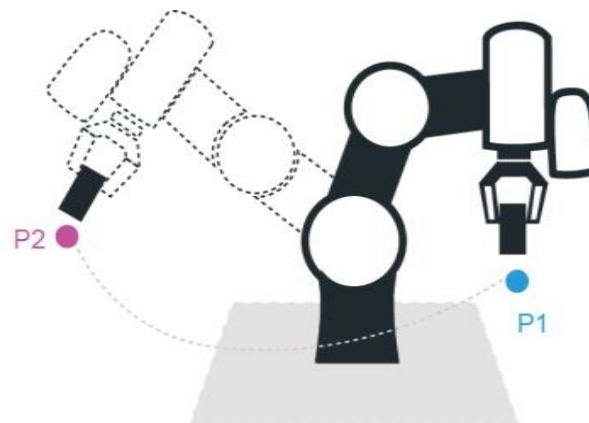

PTP Motion

### 9.2.2 Speed of PTP Motion

The PTP speed is based on the motion joint that takes the longest time. The PTP mode may cause the TCP to over speed limit, especially when the arm length is longer, and should be avoided. Speed percentage and time to top speed can be set in PTP speed setting.

### 9.2.3 Plan for PTP Movement

In the example, working with the TCP T4 to move the workpiece from P1 to P2 does not need to limit the robot movement path, using the PTP setting at the P2 Point node, after the robot reaches P1. In this case after the arm reaches P1, the fastest movement path will be planned to move to P2.

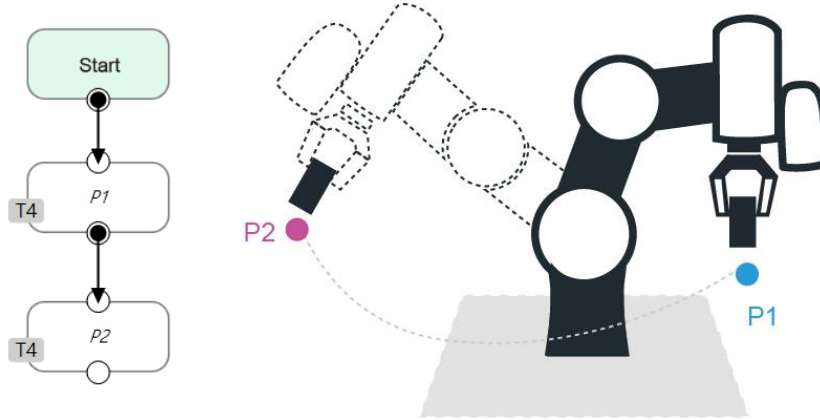

PTP Application Examples

## 9.3 Line

### 9.3.1 Line Moves the Shortest Distance

A straight line is the shortest distance between two points. The Line mode specifies that the path between the two points is planned as a straight line.

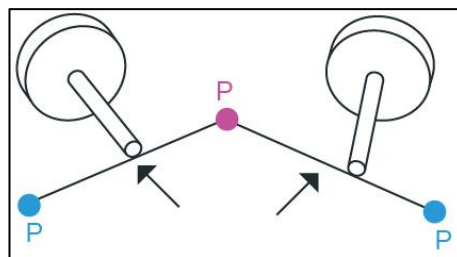

Line Motion Simulation

### 9.3.2 Speed of Line Motion

Line mode may cause joint speeding. Try to avoid speeding close to singular point, or make the posture large-angle movements over a short distance. Speed percentage and absolute speed value can be set in Line speed setting.

### 9.3.3 Plan for Line Movement

The figure below explains that this project sets two points P1, P2, and tool T22. Using the Line setting at the P3 Point node, after the arm reaches P1, it will move to P2 with Line path.

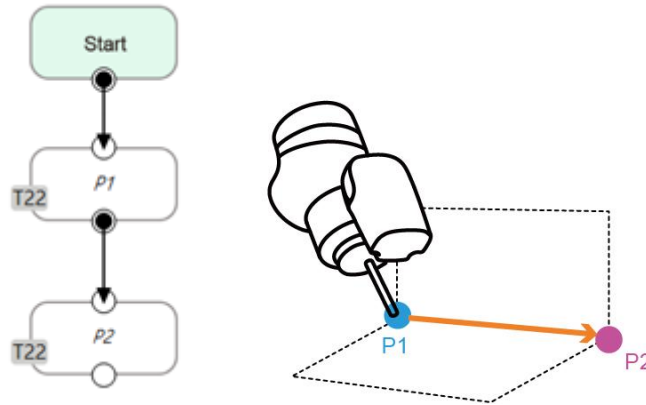

Line Application Examples



#### **IMPORTANT:**

ABS (Absolute) speed setting, including Point, Path, Move, and nodes can be used when the speed is linked with Project Speed. When not clicked, the arm motion maintains the ABS set speed. The warning window will pop up when the speed setting exceeds 250mm/s, and check automatically, display "Speed exceeds 250mm/s, needs to be linked with Project Speed".

### 9.4 Two Steps Motion(WayPoint)

#### 9.4.1 WayPoint

The 2 steps movement will maintain a part of Z-axis displacement on the point Base, after the 1st step XY axis is aligned and in position, the 2nd step will move toward Z-axis, and this is often used in the applications of pick and place objects. The 1st track is planned as PTP and the 2nd as Line.

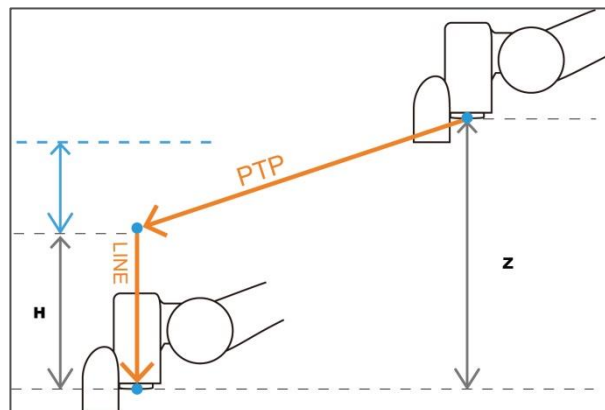

WayPoint Motion Status



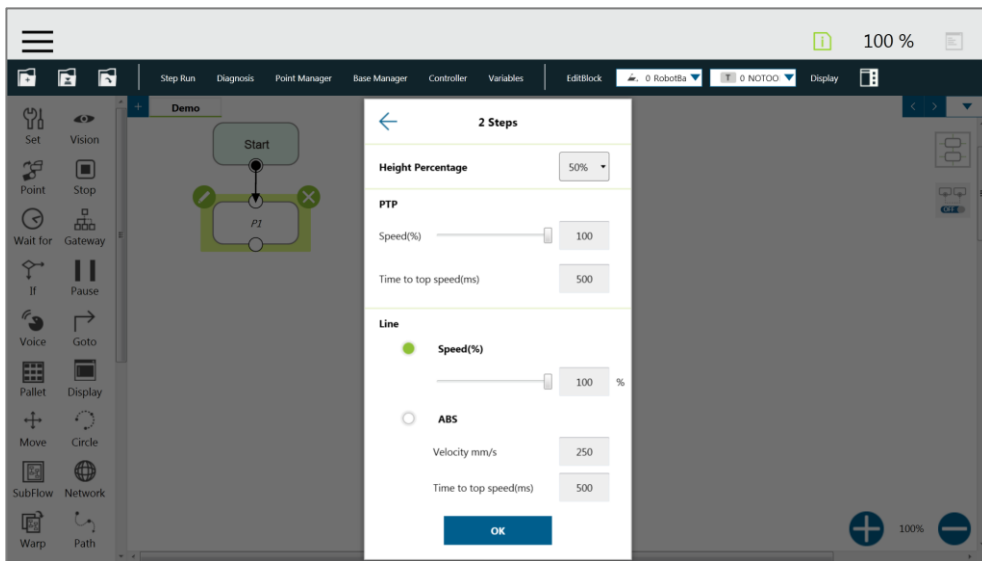
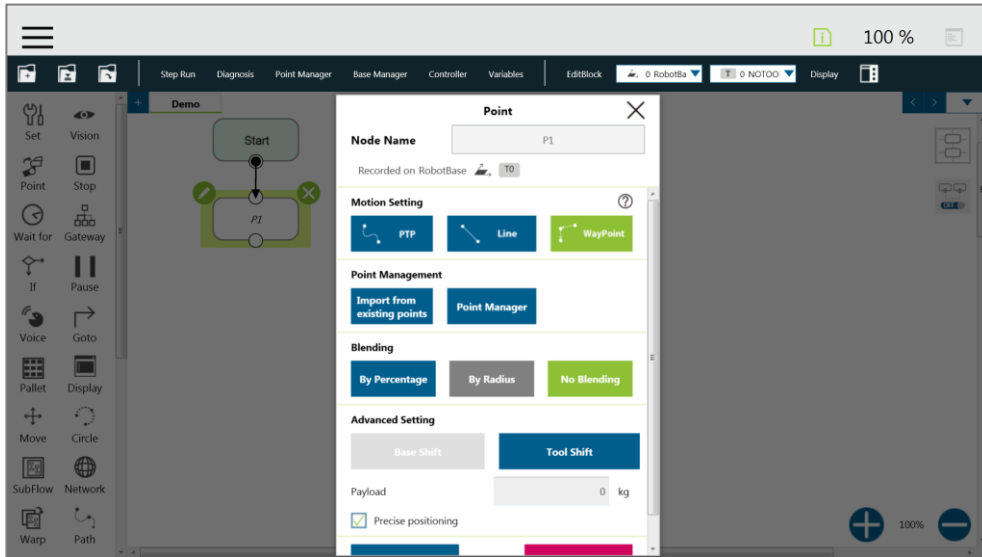

WayPoint Setting Items

#### 9.4.2 Plan for WayPoint Movement

The following figure is an example to illustrate that if there are obstacles around the workpiece to be picked, it is easy to cause robot end collision. This project creates a point P1, sets the WayPoint motion mode, retains a Z axis height before reaching P1 point, and then goes downward to pick the workpiece, to prevent collisions.

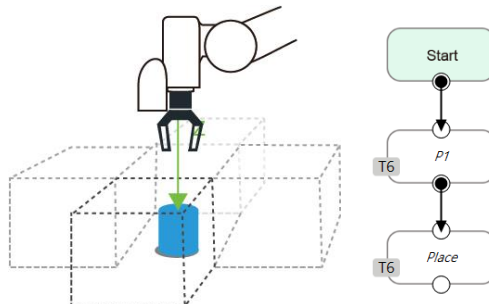

WayPoint Application Examples

## 9.5 Blending

### 9.5.1 Blending in Movement

In the process of planning for tracks, the robot will not accurately pass through each programmed point, which has the advantages of reducing the number of robotic brakes and reducing wear and shortening the cycle time. As shown in the figure below, a movement from P1 to P3 is planned, and P2 does not need to be accurate in position. At this time, Blending can be set at P2 point.

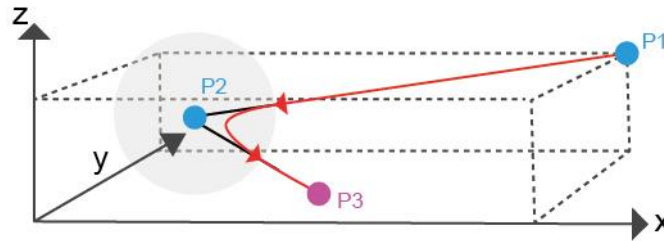

Blending in space

### 9.5.2 Blending Speed Change Chart

The cycle time can be shortened by Blending as shown in the figure below.

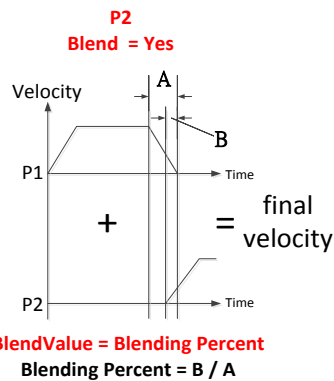

Blending speed change chart

### 9.5.3 Set the Blending Percentage

Line, PTP, Circle motion modes can click [By Percentage](#) to set the track radius.

### 9.5.4 Set the Blending by Radius

Line and PLine motion can click By Radius to set the Blending by radius. Line is a commonly used motion mode of Point Node, and PLine is a unique motion mode of Path Node. For details, refer to the sections with corresponding title of this Manual.



#### IMPORTANT:

As shown in the table below, blending can improve the smooth running of robot, but when the Blending radius has been set by Line motion, blending with Circle and PTP cannot be used.

#### Line

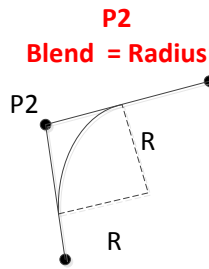

**BlendValue = R**  
**R = Blending Radius**

#### PLine

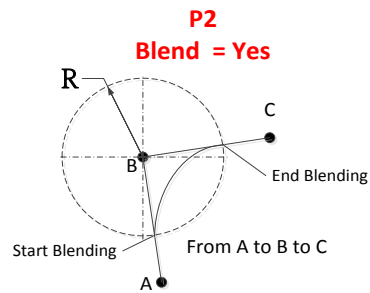

**BlendValue = Blending Percent**  
**Blending Percent = R / Distance between A&B**

The table of valid blending setting (moving from P1 to P2)

P2 P1		PLine	Line		PTP	Circle
			%	Radius		
PLine		○				
Line	%		○	○	○	○
	Radius		○	○		
PTP			○		○	○
Circle			○		○	○

## 9.6 Motion Nodes

### 9.6.1 Point Node

#### 9.6.1.1 Generation Method of Point node

TMflow currently has two methods to generate a Point. The point generated will enter the list of Point Manager.

1. Drag the Point Node from the Node Menu to the Project Editing Area to add the new point.
2. Press the "POINT Button" at the End Module to add the point.

#### 9.6.1.2 Point Node Setting

The Point Node can be set to motion mode, Blending, Base Shift and Tool Shift. The robot will determine the mode of moving to this point according to the above setting.

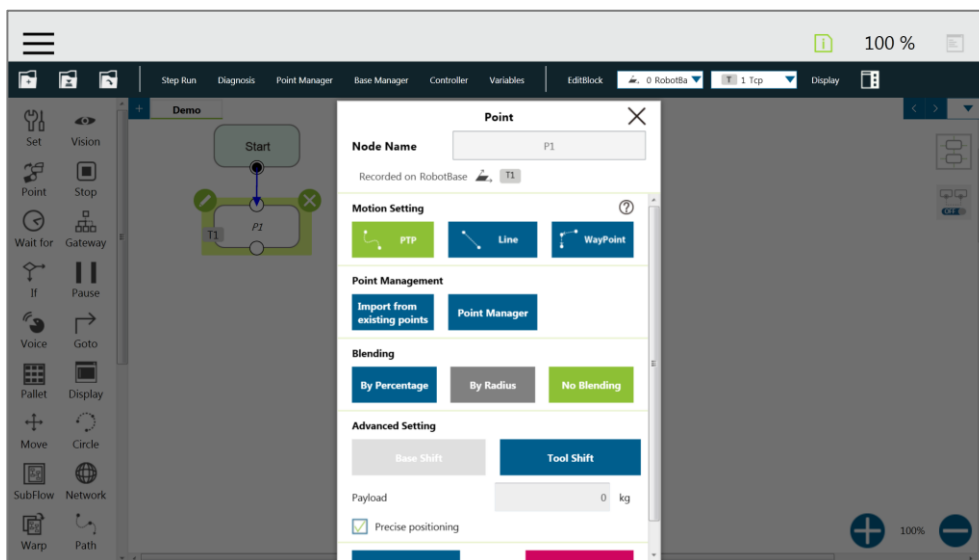

Point Node setting items

- Motion mode setting: Set motion type
- Point Management: Can choose from an existing point or open the Point Manager
- Blending setting: Set blending type
- Advanced setting: Base shifting / Tool shifting
- Payload: Load setting of robot end
- Precise positioning: Whether moves to the point precisely



#### **IMPORTANT:**

If you have not selected Precision Positioning, the robot arm will not stop at the Precision Point but instead directly move on to running the next command. If you select Precision Positioning, the robot arm will wait until motion along all axes has stabilized at the Precision Point before moving on to running the next command.

## 9.6.2 F-Point Node

This Node can perform fine tuning of X, Y, Z Axis  $\pm 10\text{mm}$  and Rx, Ry, Rz  $\pm 5^\circ$  at the existed point. During the project running, the F-Point variable can also be corrected in the “View” page. In addition, since inputting variable to fine tuning point is a dangerous action when the project is running, the login password protection is designed on the interface. Please set and use the settings appropriately.

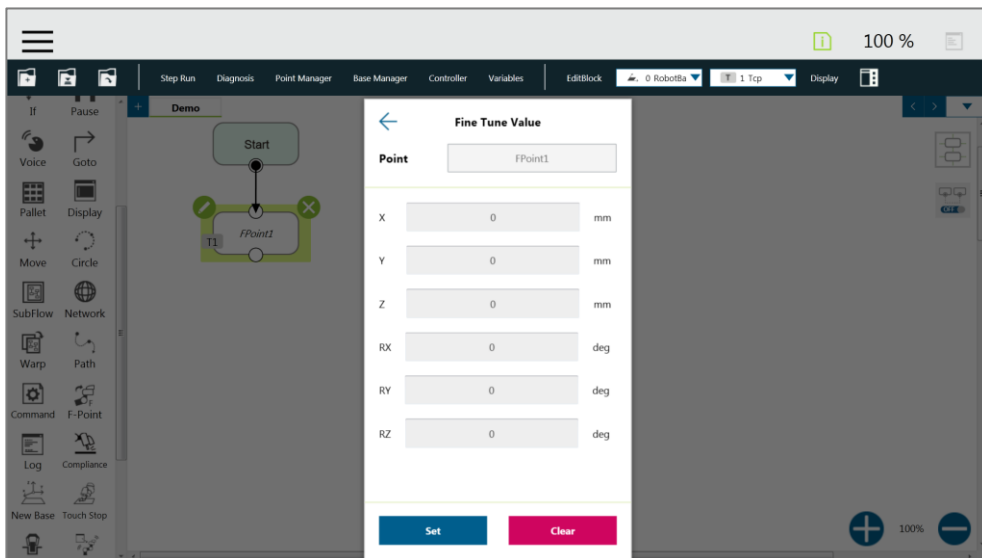
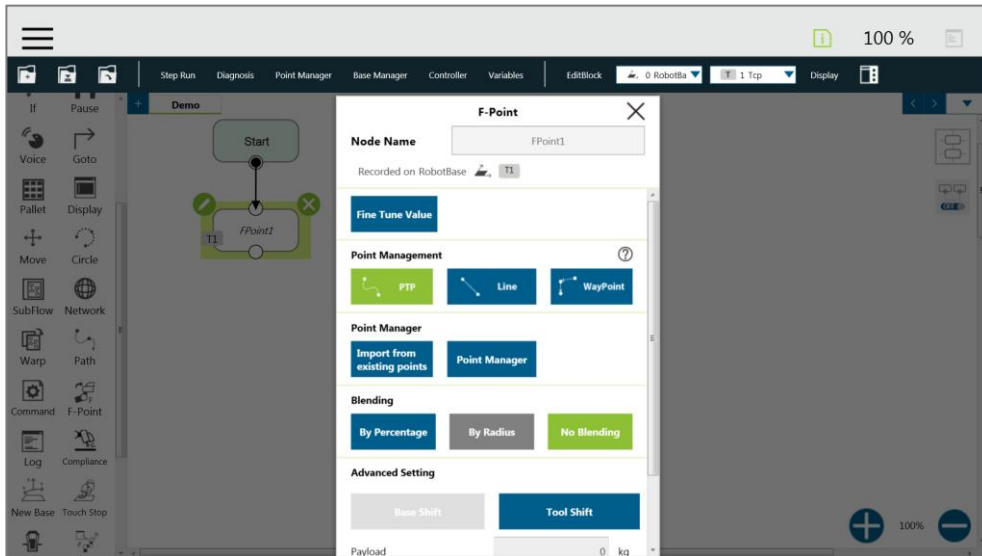

F-Point Node Settings



### IMPORTANT:

In a single project, the number limit of F-Points is 20.

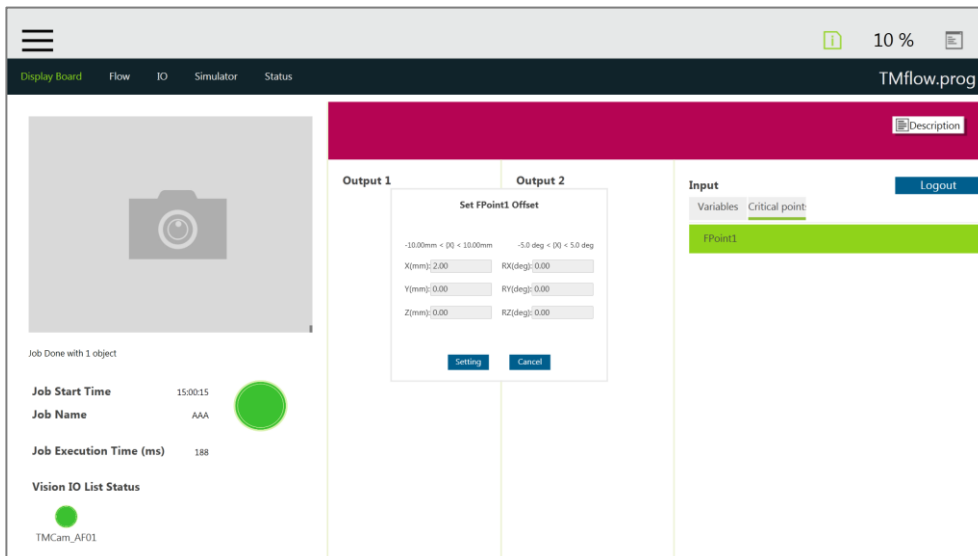

Adjust F-Point parameter during project running

### 9.6.3 Move Node

This node can set values from the Base X, Y, Z, RX, RY, RZ or six-axis angles J1~J6 to determine robot movement distance/angle, and then perform relative movement from current position.

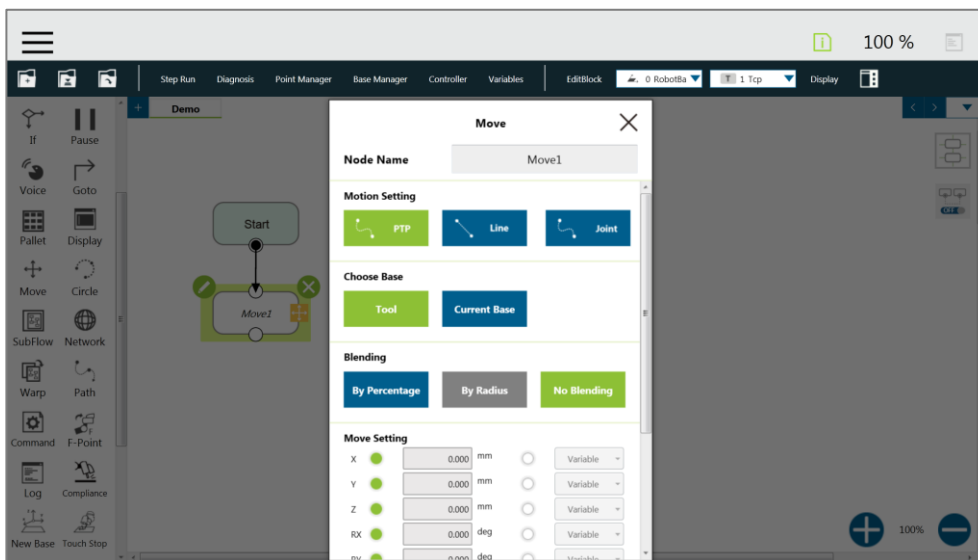

Move Node Setting Items

- Joint angles can be set to determine the relative movement of the robot
- Relative movement of distance and angle can be set
- The set relative movement distance can be replaced by a variable

## 9.6.4 Circle Node

### 9.6.4.1 Circle Node Setting

The Circle node plans the path pass through point P2 and end point P3, and uses P1 as the path start point, 3-point setting circle, and plans for arc movement.

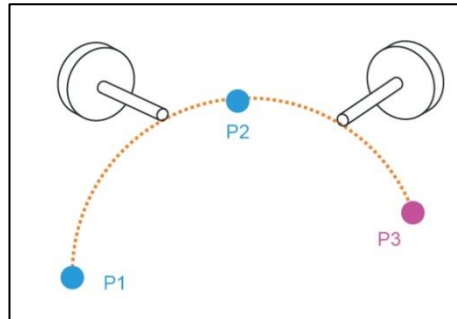

The Circle node plans arc path with 3-point setting circle

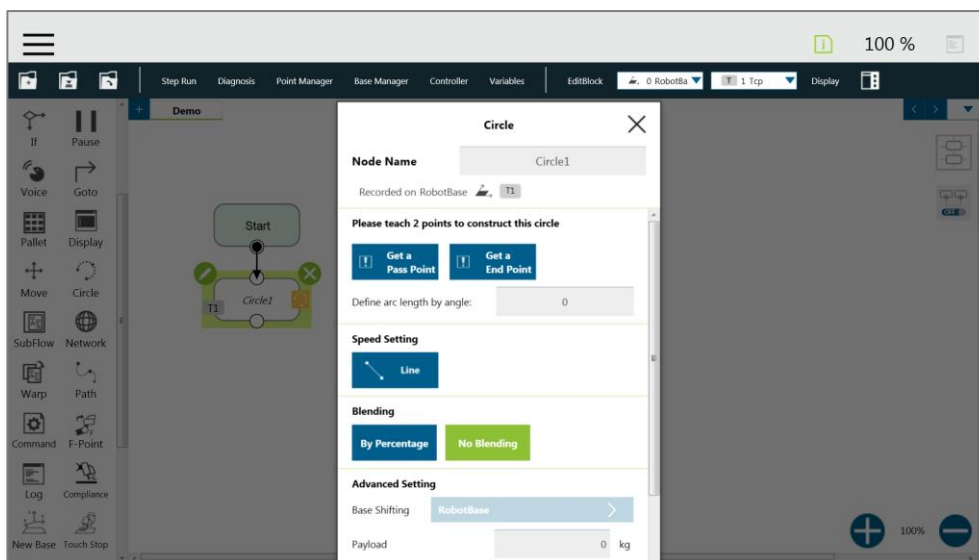

Circle Node Settings

**Step1.** Set pass through point, end point

**Step2.** Define path arc length with angle

**Step3.** Speed Setting

#### 9.6.4.2 Set Angle= 0°

3-point setting circle Users can define the path arch length with angle after setting the Circle. When set angle is 0°, the robot will move from P1 Start Point to P3 End Point through P2. At this time, **the robot posture will change with the point**, as shown in the figure below.

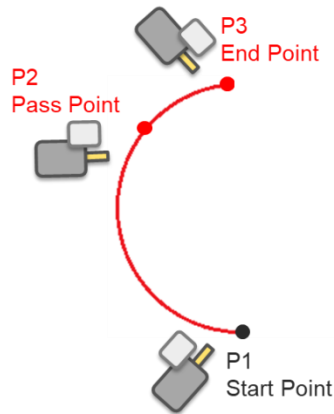

The circle motion status of set angle=0°

#### 9.6.4.3 Set Angle > 0°

Define the path arc with angle, when set angle >0°, and with 3-point setting circle, the robot moves the set angle from P1 Start Point through P2, P3. At this time, **the robot posture will fix as P1 point posture**.

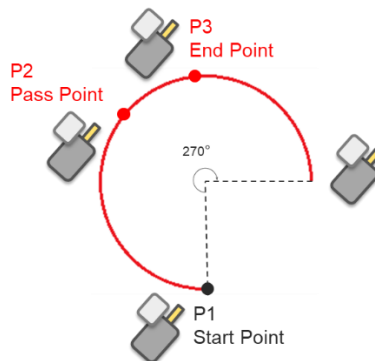

The circle motion status of set angle=270°



## 9.6.5 Path Node

This node can read and run the .Path path file and control the robot to move according to the .Path file path.

### 9.6.5.1 Path & PLine

The Path file is a collection of points that can be generated by a third-party CAD –to-Path software partnered with TM Plug&Play. PLine is a special motion mode of the Path file, and its blending setting is different from that of the Line, providing that the robot can smoothly move between dense points.

### PLine

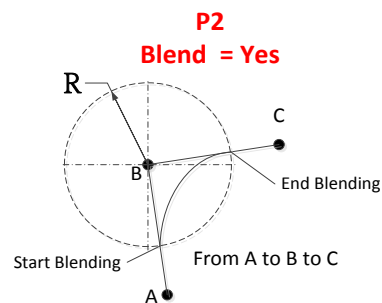

$$\text{BlendValue} = \text{Blending Percent}$$
$$\text{Blending Percent} = R / \text{Distance between A\&B}$$

PLine Blending relationship chart

### 9.6.5.2 Path Node Setting

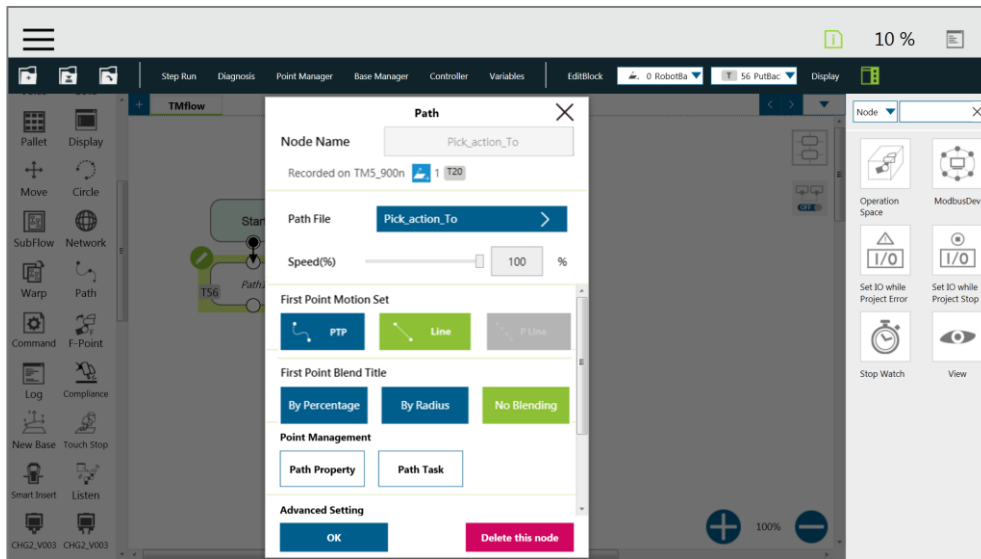

Path Node Settings

- Path File: Select Path to run from the Imported Path File
- Speed: Set the speed percentage when path is running, and valid to the 1st point at the same time.
- First Point Motion Setting: In the initial point setting, the PLine mode can be selected only when the 1st point of path is PLine, and the speed setting is only ABS.
- Path Property: Path Property displays the Tool and Base of the Path
- Path Task: IO Setting of Point on Path

### 9.6.5.3 Path File Import and Export

Please refer to 5.8.6 “Import/Export” for Path File Import/Export. When importing the Path file, import Base and Tool together, setting the same name of (i.e. Path1\_Base, Path1\_Tool) in the Base and Tool list of the flow. Path file import is only applicable to user-specified projects and preset with Robot Base and NoTool if there is no Base and Tool information.

## 9.6.6 Pallet Node

This node can set three-point coordinates and row and column values, to control the robot's motion between the row and column. There are a total of two modes, applicable to regular display applications, such as: pallet placement applications.

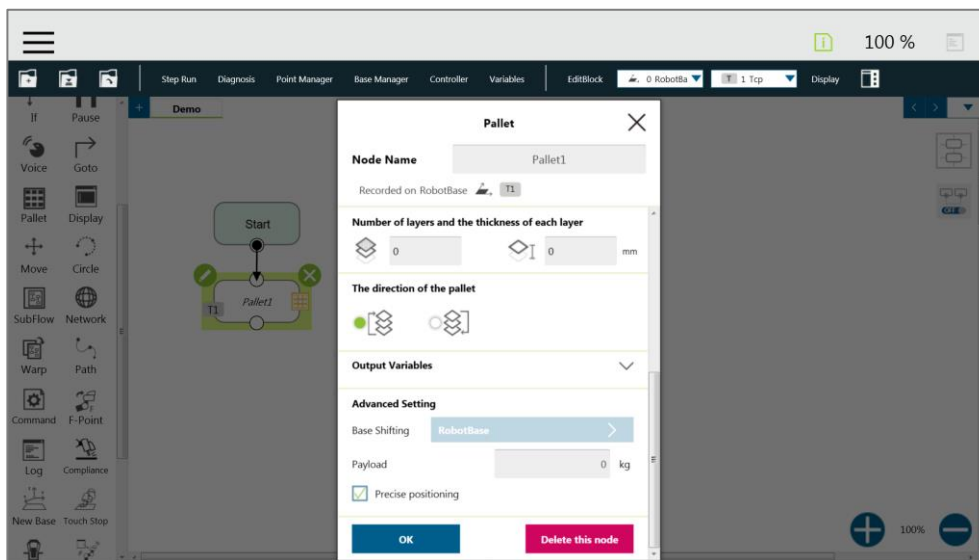
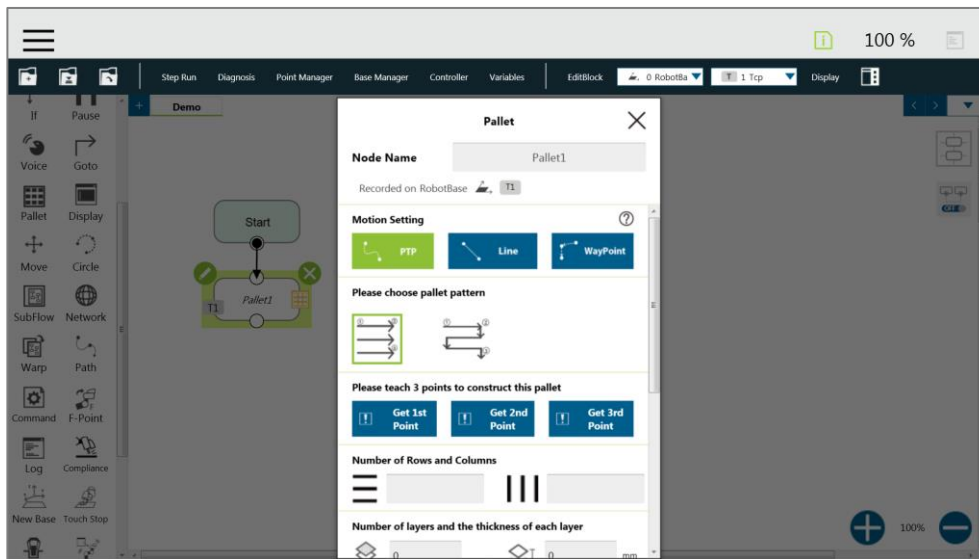

Pallet Node Settings

- 3 points establish Pallet: 1st Point is the start point of the 1st row, and determines the robot posture, 2nd Point is the end point of the 1st row, 3rd Point is the end point of the last row.
- Number of Rows and Columns: Define the number rows and columns.
- Pallet Pattern: Parallel or zig-zag

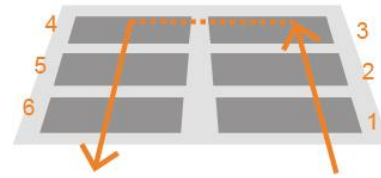
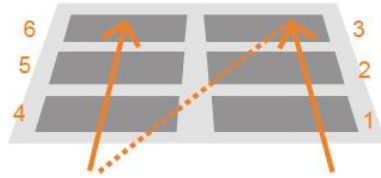
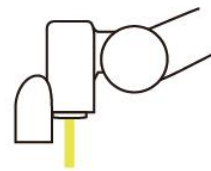
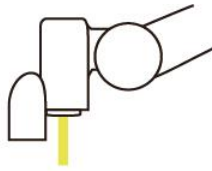

- Number of layers and the thickness of each layers: Set number of levels and height of each level
- The direction of the pallet: bottom-up or top-down
- Pallet will automatically generate a set of variables of row, column & height, connected to Pallet movement position

Note

**NOTE:**

Users can use the function of “Correlate to variable” to correlate the row and column with variables. After variables were assigned to the row and column, the variables can be used to manipulate or display which slot in the Pallet to be implemented.

**IMPORTANT**

**IMPORTANT:**

Pallet needs to work with Loop in order to move to the next position of Pallet.

### 9.6.7 Listen Node

In the Listen Node, a TCP/IP server (Socket Server) can be established and be connected by an external device to communicate according to the defined format. All the functions available in "Expression Editor" can also be executed in Listen Node.

The screenshot shows a dialog box titled "Listen" with a close button (X) in the top right corner. The dialog contains the following fields and controls:

- Node Name:** A text input field containing "Listen1".
- Send message as entering this node:** A text input field containing "\"Listen1\"".
- Print received data in log:** A checkbox that is currently unchecked.
- Connection Timeout:** A numeric input field containing "0" with a "Var" button to its right.
- Data Timeout:** A numeric input field containing "0" with a "Var" button to its right.
- Buttons:** "OK" (blue) and "Delete this node" (pink) buttons at the bottom.

- **Send Message:**  
When entering this node, it will initiate a message
- **Print Log:**  
Enable Communication Log (shown on the right)
- **Connection Timeout:**  
When entering this node, if more than the time (milliseconds) is not connected, it will be overtime.  
If  $\leq 0$ , no timeout
- **Data Timeout:**  
When connected, the timeout will be exceeded when there is no communication packet  
If  $\leq 0$ , no timeout

Socket Server is set up after the project is running and closed after the project is stopped. When the Socket Server is successfully established, the IP and Port will be displayed in the Notice Log window on the right.

IP      HMI → System → Network → IP Address

Port    5890

When the process enters the Listen Node, it stays in the Listen Node until it triggers and leaves with the exit condition.

Pass:    Executes ScriptExit() or item stopped

Fail:    1. Connection Timeout

          2. Data Timeout

          3. Before the Socket Server been established successfully, the flow process has entered the Listen Node

---

The command received by listen node will be executed in order. If the command is not valid, an error message will be returned carrying the line number with errors. If the command is valid, it will be executed.

The command can be divided into two categories. The first category is commands which can be accomplished in instance, like assigning variable value. The second category is commands needs to be executed in sequence, like motion command and IO value assigning. The second category command will be placed in queue and executed in order. About the detail command list and communication format, refer to manual, "Expression and Function of Expression Editor and Listen Node".

## 10. Logic Programming

### 10.1 Overview

This Chapter will introduce the logic nodes commonly used in TMflow programming, explain its basic features and use methods, and let users understand how to let robots understand instructions and commands and determine the next motion. In the area of logic programming, the most important is the application of variables. In TMflow, the variables are mainly divided into two categories: global variables and local variables, therefore, this chapter will introduce variables first and teach them how to assign variables, then conduct basic explanations and examples of how the logic nodes are paired with these variables.

### 10.2 Variable System

#### 10.2.1 Local Variables

The local variables can only be called in a single project, and its effective range is only within the project that created these variables. The creation method can enter into the variable system on top of TMflow. In this page, a single variable or array variable can be declared and assigned with the value. According to the different data formats, TMflow provides six types of variables of int, float, string, double, bool, and byte. The physical meaning of the variables is shown in the Table below. If no value is assigned, then preset the string initial value as empty, and the remaining variables are all 0. The newly added local variables will appear in the project's variable system, and begin with "var\_" to represent the local variables in the variable system.

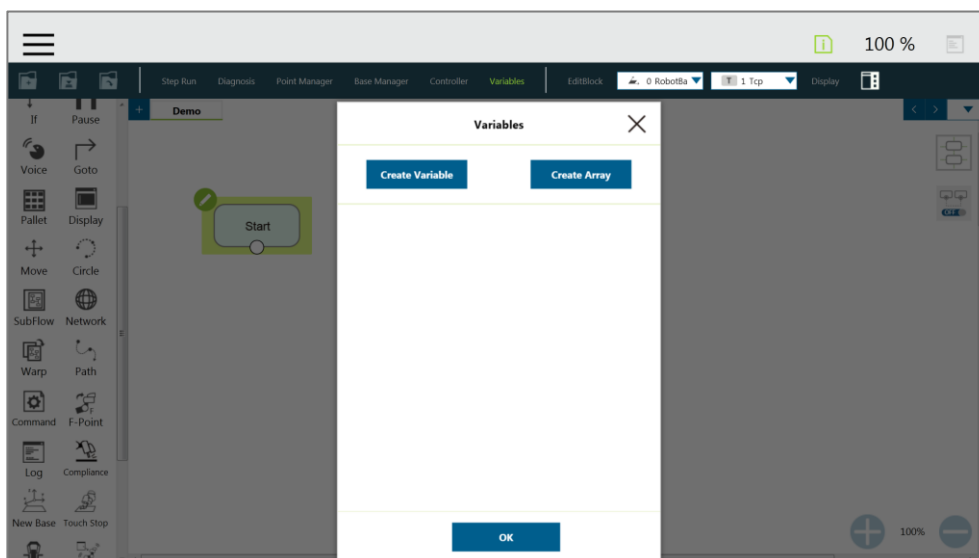

Variable System

## Variable Type

Type	Type Description	Saved Data
string	String	Structure composed of characters, such as "TMflow" (double quotes must be added to represent the string)
int	Integer	$-2^{31} \sim 2^{31} - 1$
float	Floating point number (decimal)	$10^{-37} \sim 10^{38}$ (Effective digit 6~7 digits)
double	Double-precision floating-point number	$10^{-307} \sim 10^{308}$ (Effective digit 15~16 digits)
bool	Boolean	True, False
byte	Byte	$-2^7 \sim 2^7 - 1$

After clicking the newly added variable, the declaration of variable can be performed. For example, the integer type variable `TM_Robot=0` can be declared.

In addition to declaring a single variable, arrays can also be declared. The array declaration method is to set the name of the array variable and the size of the array. The default value is 0. As shown in the following figure, an array with size 10 and name `Array` is declared, so the array `{0, 0, 0, 0, 0, 0, 0, 0, 0, 0}` can be obtained. If the user wants to obtain the first value of the array, `TM_Robot[0]` can be called in calling the array SET Node.



### **IMPORTANT:**

The corresponding number of the first element of the array is 0, and so on.



### 10.2.1.1 Global Variables

The global variables can be accessed by clicking "Global Settings" on the "Robot Setting" page. Global variables can pass values to each other in different projects, that is, the global variable values can be accessed or changed in different projects. As shown in the figure, an integer type global variable is declared as Global=0. The newly added global variable will appear in the project's variable and it will be represented as a global variable starting with "g\_". Test with the examples of the following figure, in this project each time after the SET node, the global variable g\_Global number is increased by 1, after running the project 66 times, press stop on the Robot Stick to end the project, at this time, the global variable declaration page changes the number to 66. At this time, this variable is used by other projects, the initial value will be 66, with this method to complete passing and interactive use of the between different projects.

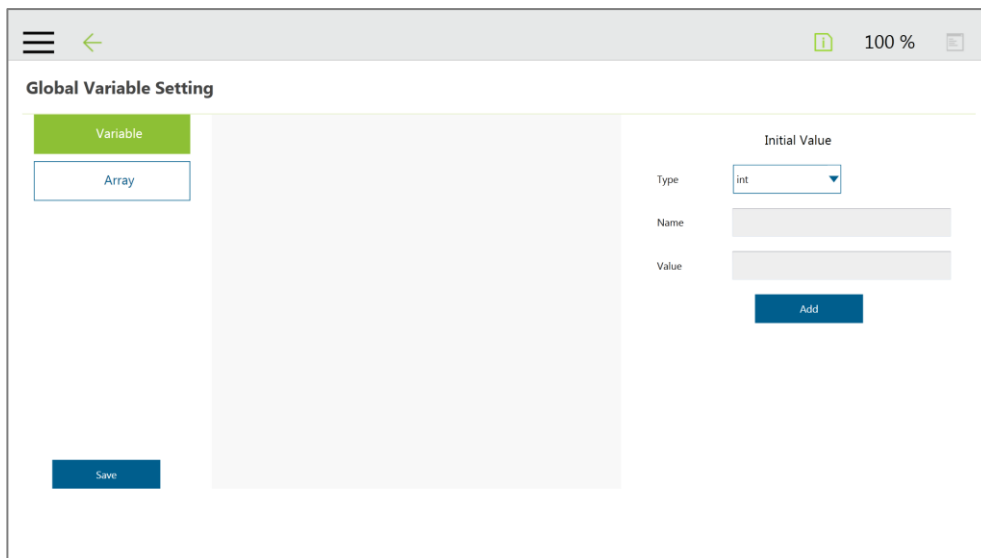

Declare Global Variables



#### **IMPORTANT:**

Global variables will not be initialized when the system shuts down.

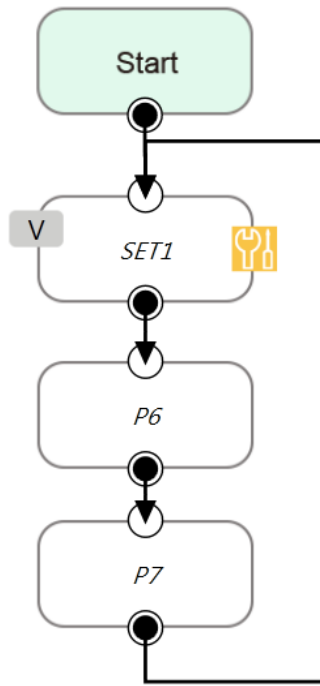

Global variables used in the product

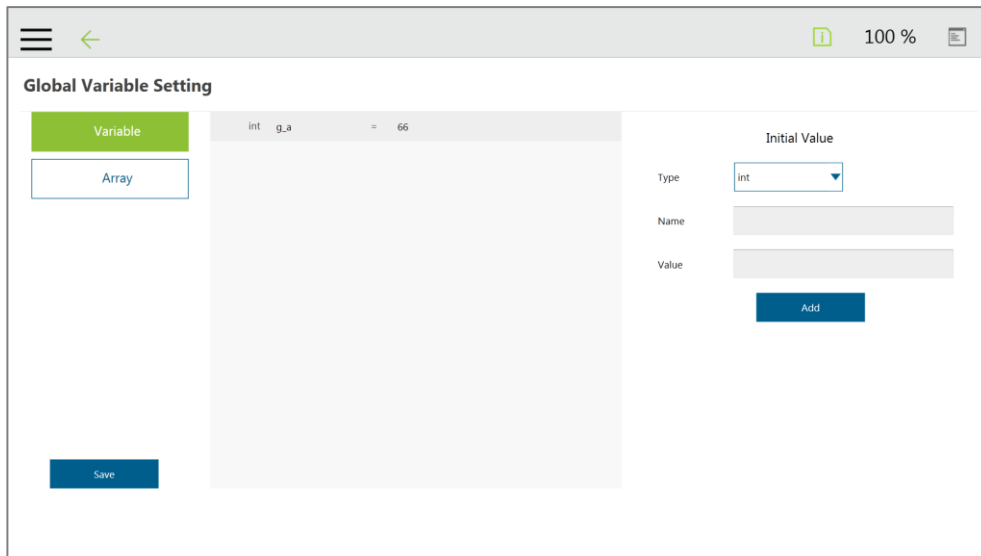

Global variables after project is run

## 10.3 Logic Nodes

### 10.3.1 SET Node

This node can set the states of IO, and change the type and value of the variables. When passing through this node, all parameters will be changed to the set result.

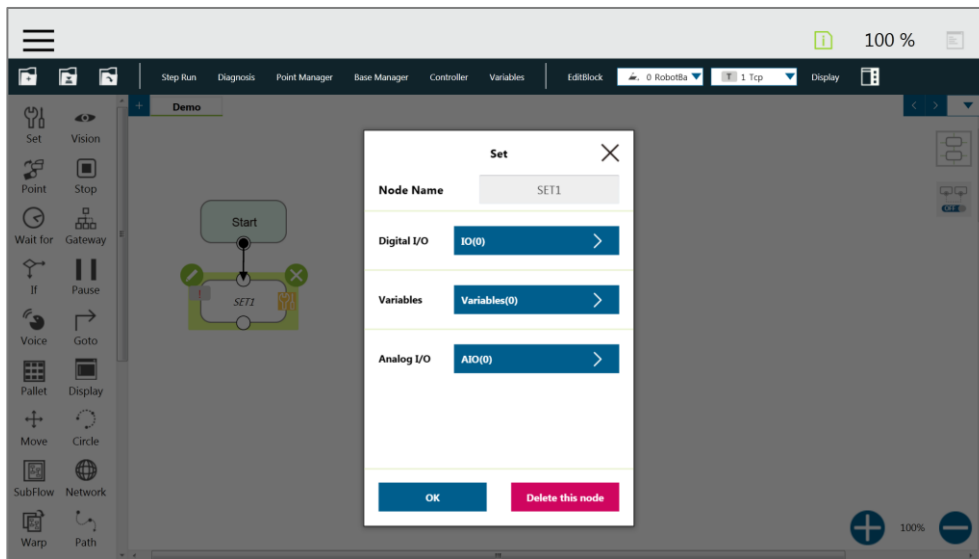

SET node

In the application of variables, the SET Node can add and subtract variables, often working with the IF Node to select the path, or interrupt the infinite path of the project. As shown in the figure below, set an integer type of variable count=0. Each time passing through the SET Node, the count value is added by 1. Finally, working with Display to display the number of times the project is repeatedly running.

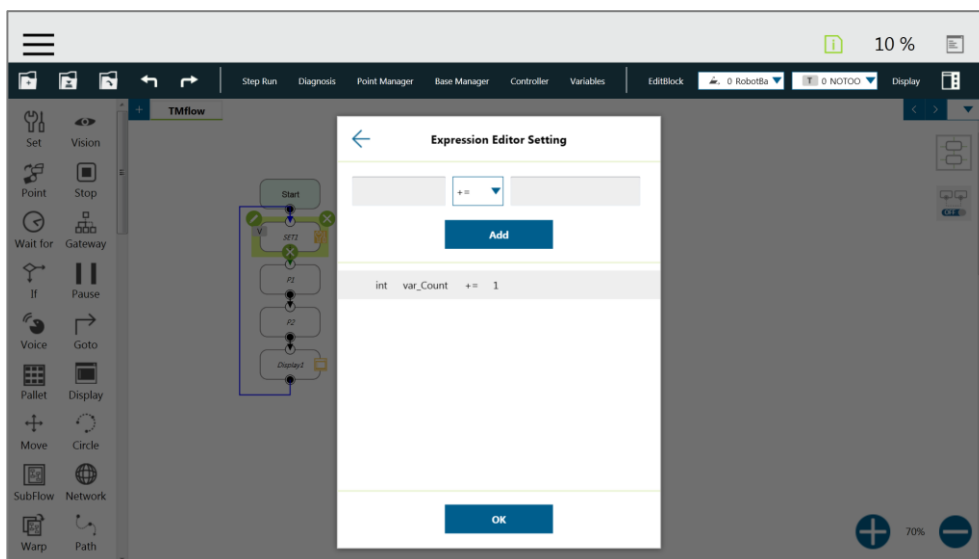

Variable count

### SET symbol list

Symbol	Symbol description
$a += b$	$a = a + b$
$a -= b$	$a = a - b$
$a *= b$	$a = a * b$
$a /= b$	$a = a / b$
$a = b$	Specified a Value is b

In the box below, the existing variables can be selected and used for calculation.

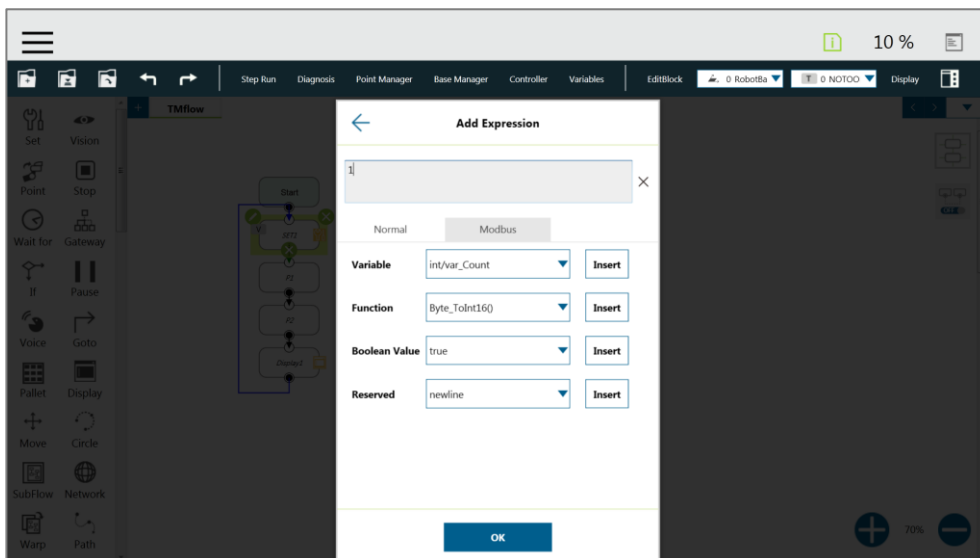

Expression Edit

The SET Node can also set the Analog IO, when enabling Analog IO when passing through the SET Node and giving the external device with a specific voltage, until after the path (Path1) is completed, and the output voltage value is stopped.

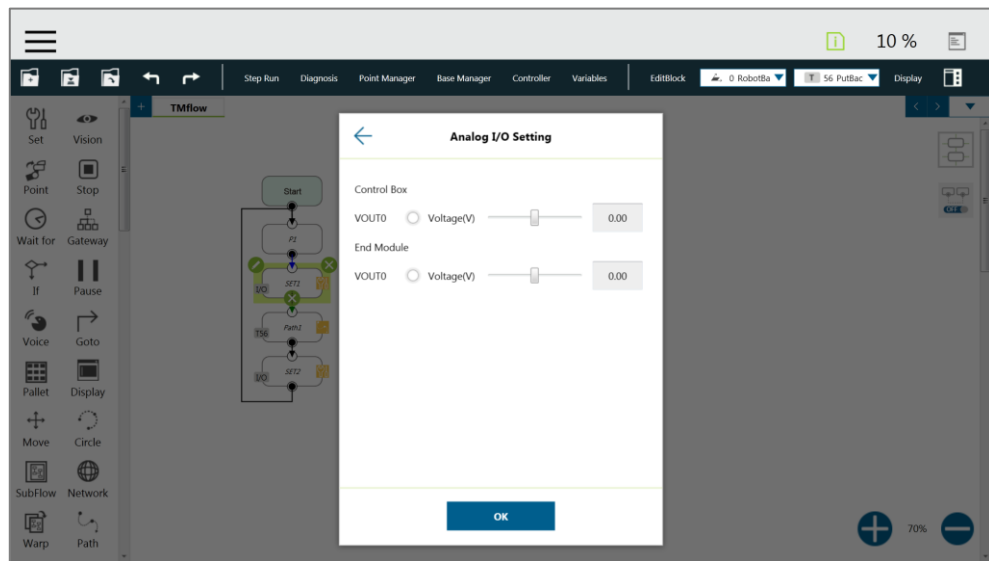

Analog IO Applications

### 10.3.2 IF Node

In actual robot running, different conditions may occur due to many factors. For example, job failure, success, and communication errors may occur in various function nodes. These results will return the corresponding variable values. The user can use the IF node to handle these conditions according to different variables. The IF can judge or compare the state of IO, the state of variable, and judge the compliance. And take the Yes or No path according to whether the condition of the judgment is reached.

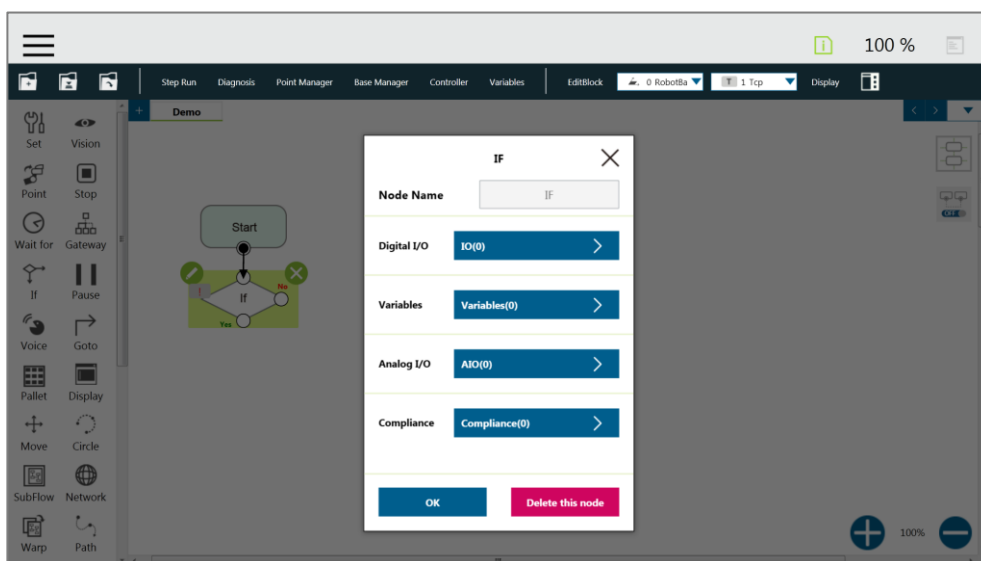

IF Node

## IF Judgment Symbol

Symbol	Symbol Description
<	Less than
>	More than
==	Equal to
<=	Less than or Equal to
>=	More than or Equal to
!=	Not Equal to

And in the judgment of Compliance, as shown in the figure below, the variables obtained from using the result of Compliance in this project to program the follow-up flow.

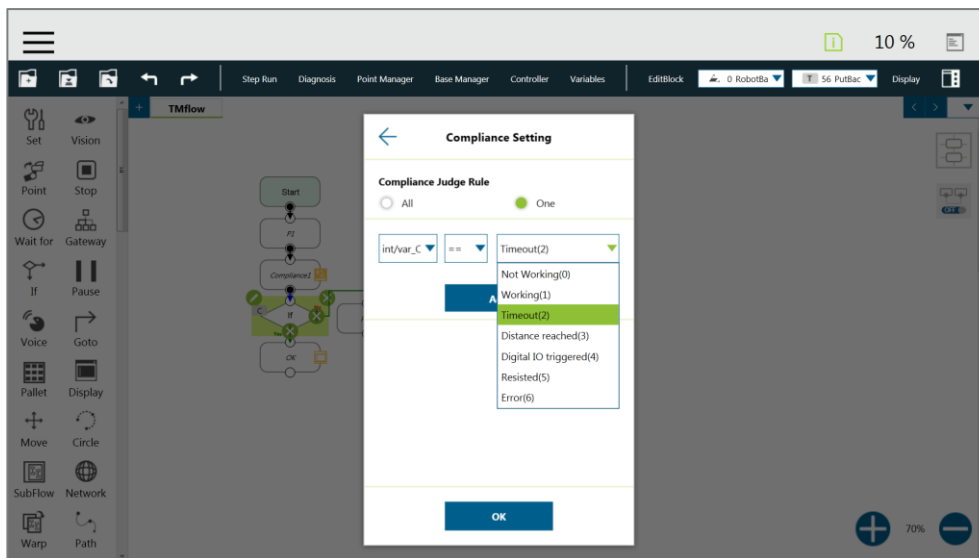

IF node Compliance variable judgment

### 10.3.3 WaitFor Node

The main function of the WaitFor Node is to hold the project, and continue to run after the set conditions are met. It can be set according to IO, Time, Variables and other conditions to judge whether to start the run.

### 10.3.4 Gateway Node

The Gateway Node is a conditional judgment formula similar to the IF Node. When it is used, a corresponding number of sub-nodes will be generated automatically according to the settings. The user can set the meeting conditions for these sub-nodes, and judge according to the conditions from top down. When the condition is met, the judgment of the next sub-node is no longer performed, as shown in the figure below. The user sets five cases, therefore, five sub-nodes are generated in the flow.

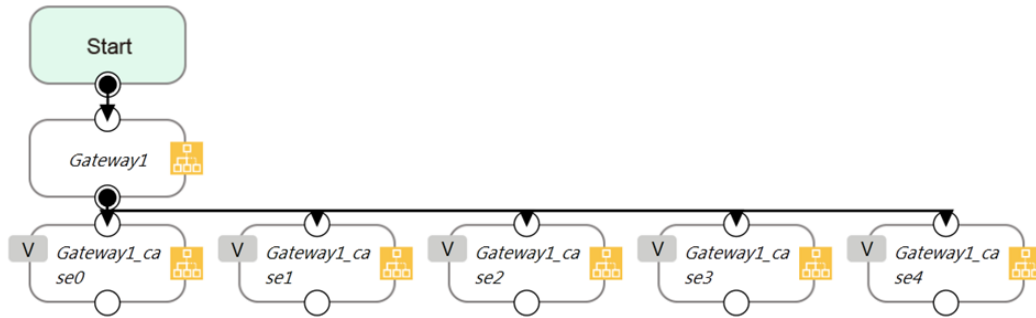

Gateway Node judges five conditions

From the vision point of view, Gateway can simplify the layout and increase the visibility of the flow.

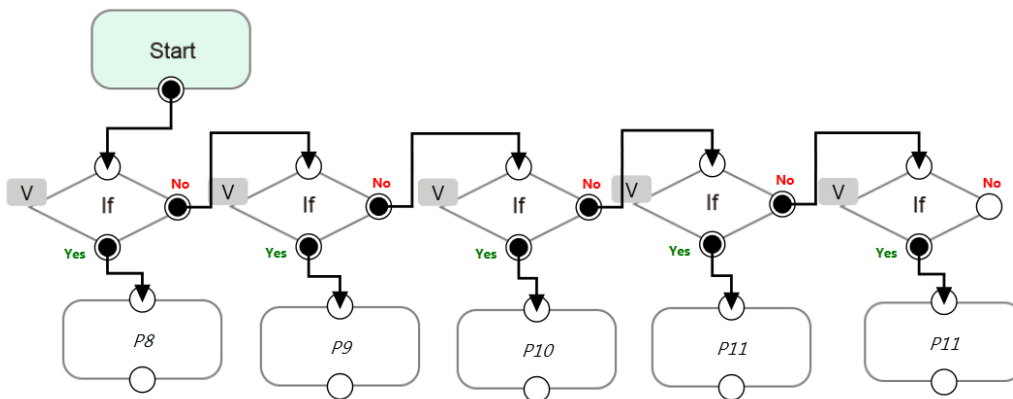

IF Node judges five conditions



**NOTE:**

If the gateway case is pulled empty, it represents the judgment condition of none of the above.

## 10.4 Process

### 10.4.1 Process Nodes

Flow nodes are mainly divided into four major categories: Pause, Stop, Goto, and Warp. And, the function of Pause node is the same as the pause on the Robot Stick. During the project running, if passing the Pause node, the project is paused, at this time, the Robot Stick can be used to restore the original behavior of robot motion. User can use voice function in a pause node, robot will read out the content when reaches the node.

The function of Stop Node is the same as the Stop Button on the Robot Stick, as shown in the figure below. During the project running, if passing the Stop Node, the project is ended. No node can be connected after Stop. If Stop node does not exist in the flow, the project will not end automatically. It is necessary to press the Stop Button on the Robot Stick again to end the project.

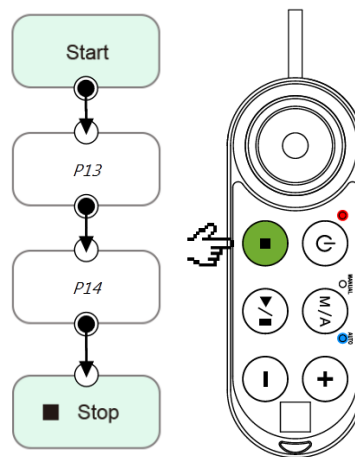

Stop Node ends Project



The Goto Node provides the user with unconditional transfer in the TMflow. When passing through this Node, it will directly transfer to the set target Node, as shown in the figure, to use the Goto Node. If the condition of the judgment formula is met, the next step transfers to P1 directly. Although the application of Goto can be achieved using the connection method, the complexity of the line will reduce the readability of the flow. The Goto Node will display the connection path only when the node is clicked, and the path of the connection will be displayed and indicated by red lines.

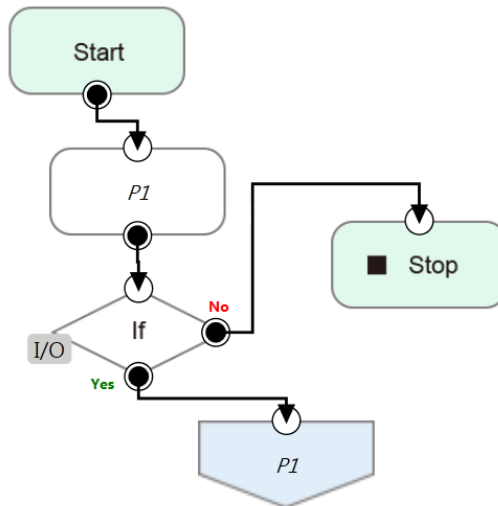

Goto Node Flow Transfer

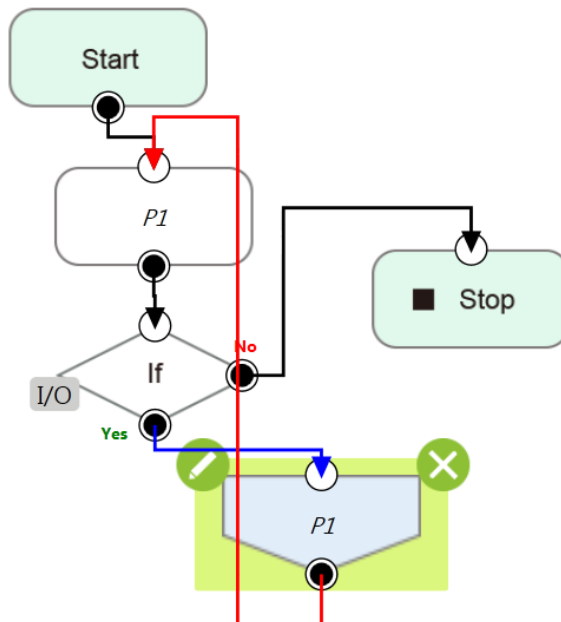

Goto Node Connection

The Warp Node can be directly transferred to another project and run, cannot connect with any node later, and the parameters of variables, Base, and Tools will not pass to another project. If the user wants to transfer variables between two projects, global variables can be used. As shown in the figure, when the TMflow of project runs beyond the Warp Node, the project is transferred to another project.

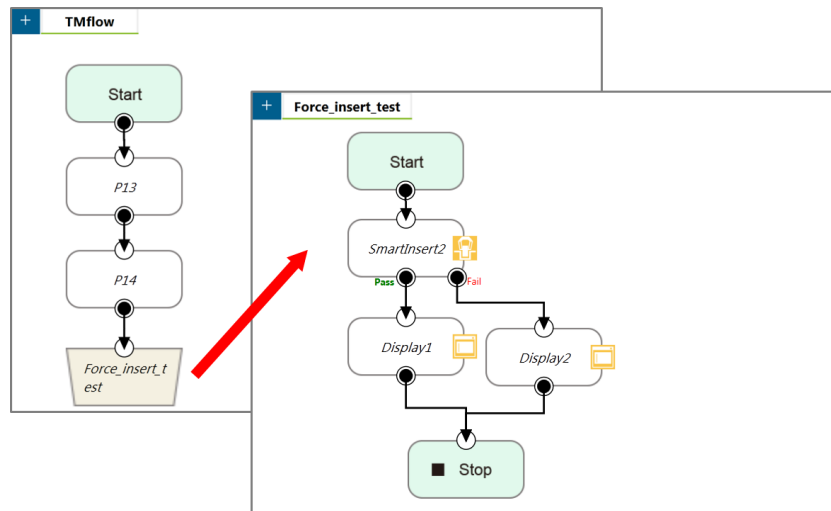

Warp Node transfers to another project

#### 10.4.2 Subflow Node

When the number of Nodes in the flow becomes larger and larger, certain blocks of the project may be used repeatedly. If the Nodes in these repeated blocks need to be modified, it may cause inconsistencies in the parameters, therefore, the Subflow Node of TMflow can be used. This Node will create a new page, and share the variables, tool parameters, Bases with the original page. The concept of modularization created with this method allows the user to simplify the project editing flow, and improves the readability of the flow. Duringflow programming, it is recommended to use Subflow to simplify the whole flow, as shown in the figure, in this project the nodes running the same action only need to be programmed once.

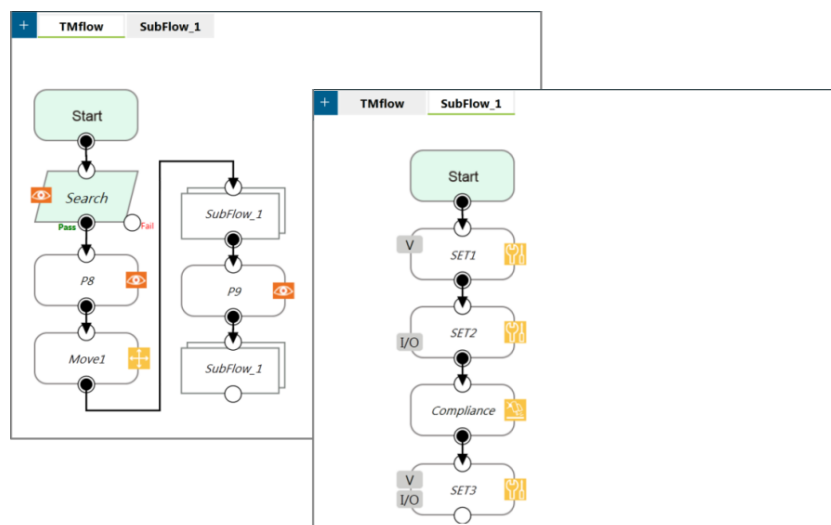

Subflow Node Modularization Concept

The Subflow Node can be dragged into the flow from the Node Menu. If the current project does not have any Subflow page, then a new page will be added automatically. If the current project already has Subflow page, then a query box will pop up whether to create a new page. In addition, the query pop up on the top left of the flow can be clicked and add new Subflow page, then make it corresponded to the Subflow page through editing of the Subflow Node. If this page needs to be deleted, then click the Edit icon of the Start Node in the Subflow page to delete.

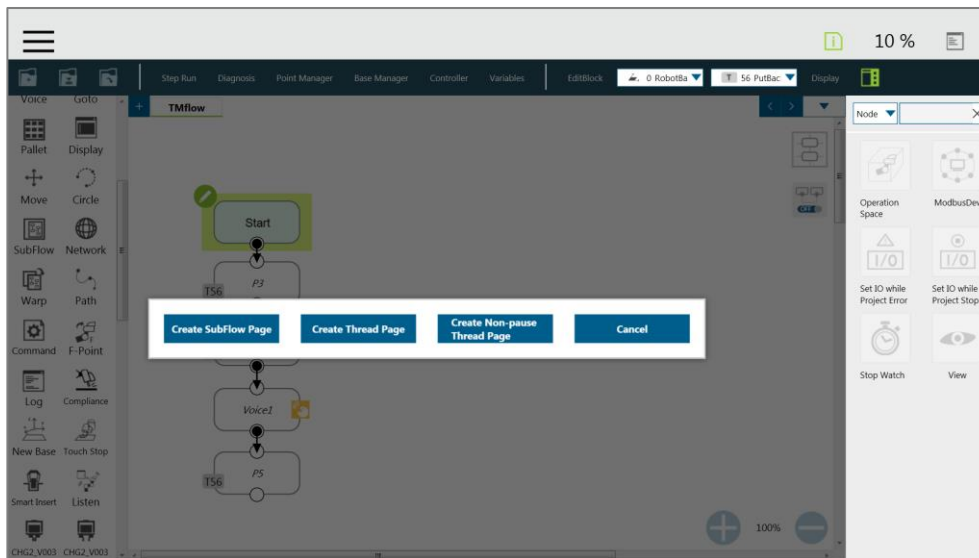

Menu to create Subpages

### 10.4.3 Thread

TMflow provides the function of Thread, allowing state monitoring and data acquisition to be independent from the robot. Click the query box pop up on the top left of the flow tab to add Thread page.

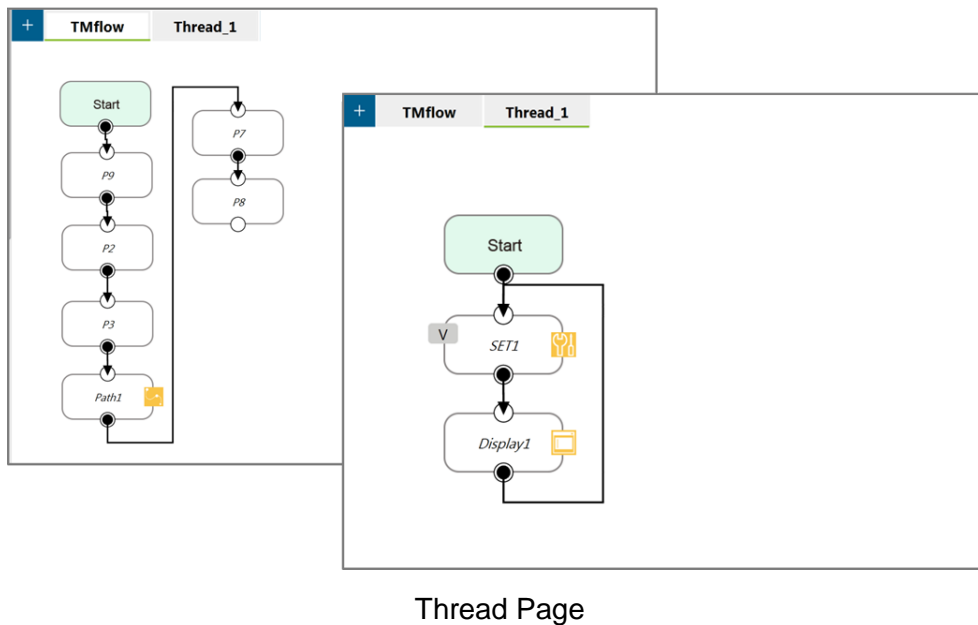

Inside the Thread page, only these actions can be added to the Project Editing Page: using the logic to judge, display the value of the node, and cannot use the motion type Nodes. The Thread pages are divided into two types. The first one is when the project pauses, the Thread page is also paused at the same time. The other is when the project is paused, the Thread page does not pause, and the user can still get the data or update the variables in the Thread page and view in Display, the window frame is presented in blue. If the page needs to be deleted, then click the Edit icon of the Start node in the subpage to delete.

## 11. Vision Node

Vision Node provides the creation of plane with fixed-point type, servo type, and object type as well as a variety of AOI identification functions. The display of Vision Node in flow, in the most complicated situation, each affiliate icon is shown as in the figure below: The Base icon on the right side is for which Base is to record the vision node of this vision job, the Base icon on the left side is for which Base is be generated by this vision job.

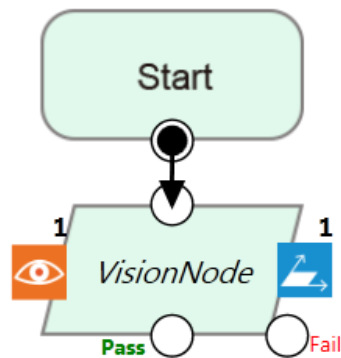

TM Robot records the relative relationship of objects by recording the points on different Vision Bases. When the environment changes, the robot can be compensated by the principle of coordinate transformation without re-teaching the robot's point positions. The position, as shown in the following figure, records the point P1 on the Vision Base to complete the task of pick and place, and performs the placement operation at the fixed position P2.

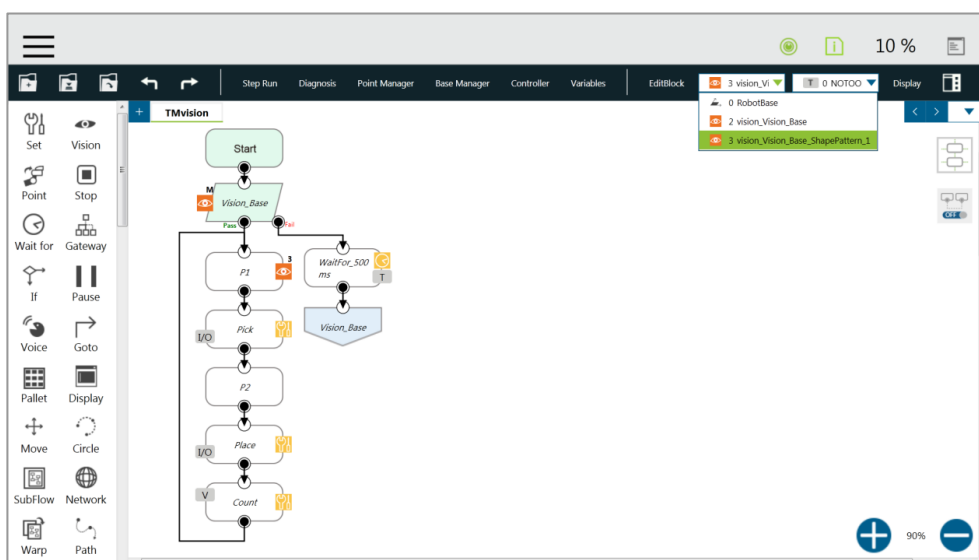

Part of the vision functions can generate variables such as the string of the barcode, the number of objects, the color of identify, and etc. The following is a multi-object recognition function, which outputs the number of objects found.

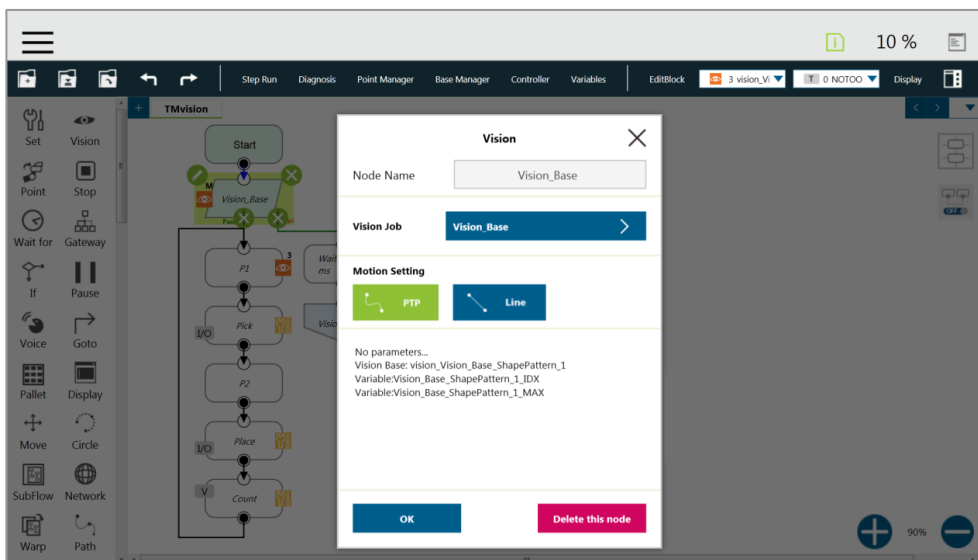

#### **IMPORTANT:**

When using the Vision Bases, make sure to choose the correct Base from the list on the upper right corner as Current Base.

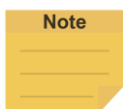

#### **NOTE:**

If the user chooses an incorrect Base, user can use the “Re-record on another base” function in Point Manager to re-record the point to the correct Base.

Please reference to “Software Manual: TMvision” for further details.

## 12. Communication and Display

### 12.1 Modbus

Modbus is a Master/ Slave type communication protocol (Master/ Slave), the user can use Modbus Master to read or write the parameters and save them in the robot register, such as position, posture and IO status. User can program with the obtained parameters or monitor the status of robot. TM Robot provides two communication protocols: Modbus TCP and Modbus RTU, at the roles of Master and Slave can be existed at the same time. The user can get the data from the external Modbus device or robot register. The external device \, such as, IPC, PLC as Master, can also sends command to the TM Robot to get the related data.

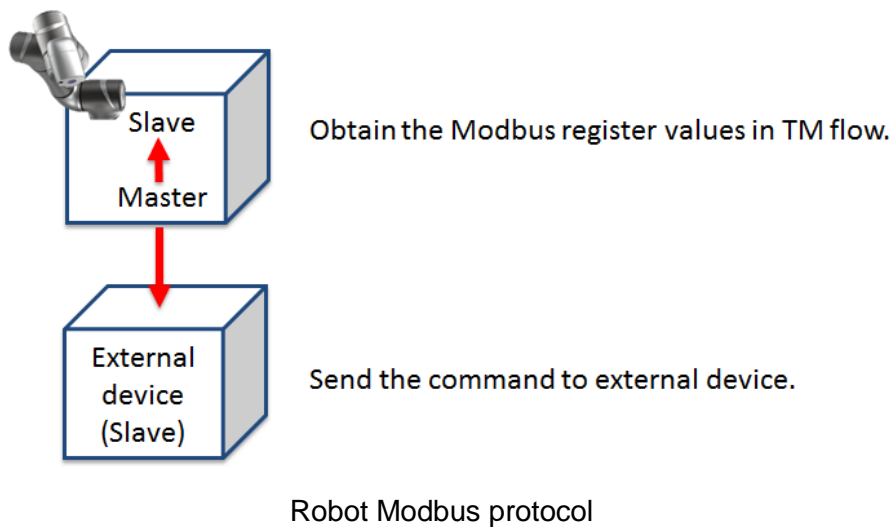

#### Note

#### NOTE:

Master is also called as Client; Slave is also called as Server.

#### 12.1.1 Modbus System Hardware Structure

Modbus is divided into two communication protocols: Modbus TCP and Modbus RTU. Modbus TCP uses RJ45 for communication and there is only one position in the Control Box that can use RJ45 to perform communication of Modbus TCP: The “LAN” port marked in the “Hardware Installation Manual”. In the case of Modbus RTU, it uses serial port for communication. Regarding the above connection approaches, see the instructions of “Hardware Installation Manual” for the position of the connectors.

## 12.1.2 Modbus System Software Structure

### 12.1.2.1 Set Modbus TCP

In the TMflow "Setting" Page, Click Modbus to access "Modbus Slave" Page, the user must confirm the IP is obtained in order to enable the Modbus TCP function. IP filter can set the network mask, and the communication with the robot must be in the set domain.

### 12.1.2.2 Set Modbus RTU

In the "Modbus Slave" RTU setting page, parameters need to be synchronised with the external device before usage. After the parameters are confirmed, Modbus RTU then can be opened through the Serial port, allowing the robot to communicate with difference devices.

### 12.1.3 Application of Modbus in Project

The value obtained by Modbus can be used for many applications, such as writing robot's own status to an external device via Modbus. The settings inside the TCP / RTU devices are the same. This Chapter will use the Modbus TCP reading the robot's x direction coordinates as the example for description.

TM Robot coordinates in the Modbus list

Name	FC	Address <sub>10</sub>	Address <sub>16</sub>	Type	R/W
X	04	7001~7002	1B59~1B5A	Float	R
Y	04	7003~7004	1B5B~1B5C	Float	R
Z	04	7005~7006	1B5D~1B5E	Float	R

First click ModbusDev from the list on the right side of TMflow to build the relevant parameters for the TCP device.

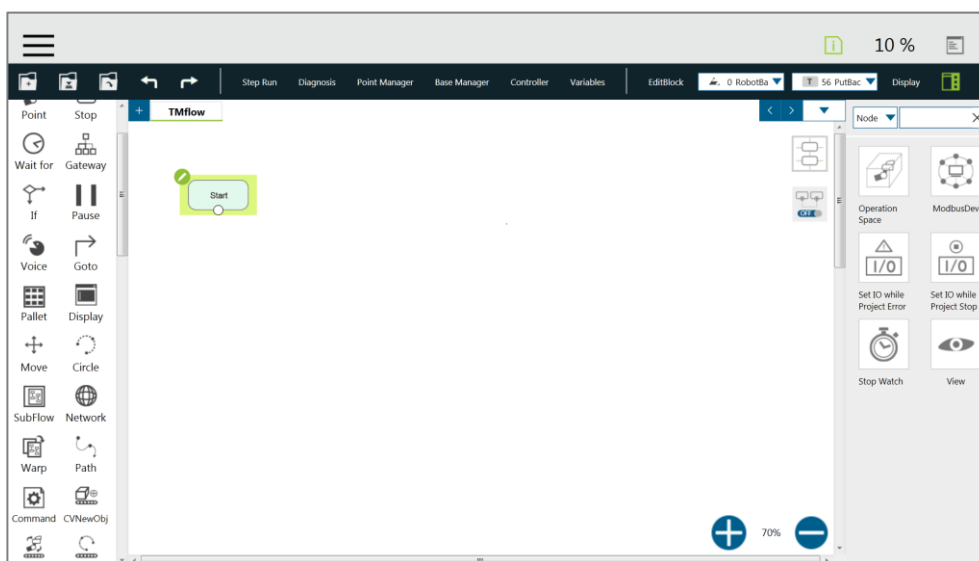

ModbusDev Access Page



After adding TCP device, the user can set the parameters of TCP device, such as name, address and other related information. After completing the setting, press OK button to save. Using TMflow to get the robot parameters, users can directly use the preset local IP to operate. Then, click Edit to add the pre-read/write location in this device.

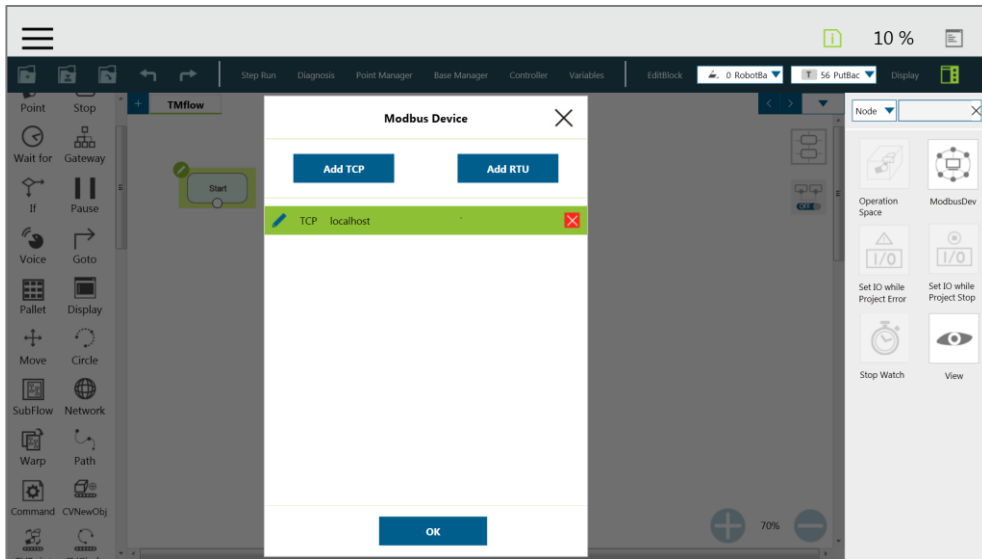

Modbus TCP Local IP

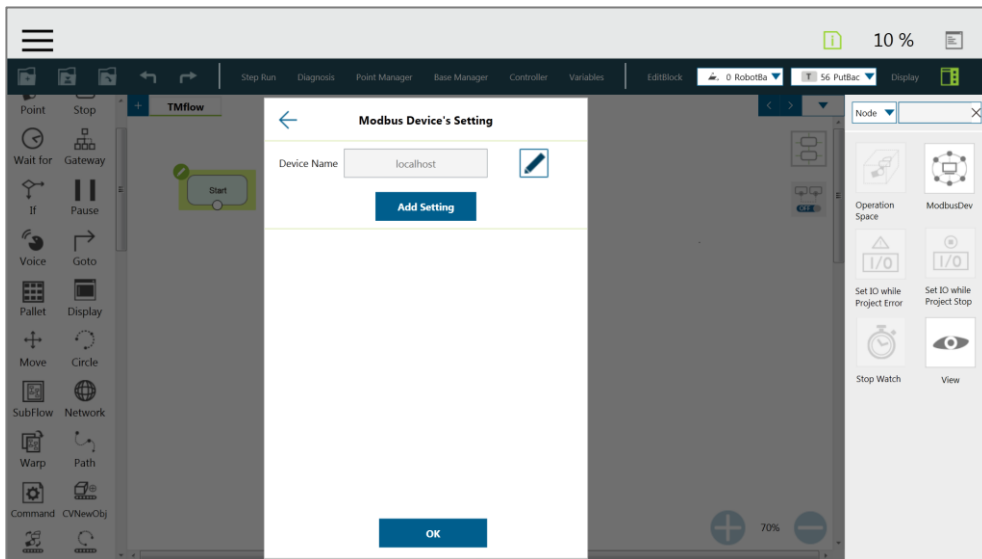

Modbus Device Setting

**IMPORTANT**

**IMPORTANT:**

If communicating with an external device, then it is necessary to set the IP address and related parameters of the external device.

The users can view the list of Modbus, in the lower left of the Modbus setting page, and input address of 7001, variable type as Float according to the list. After completed setting, the user can program the Flow, and the subsequent maintenance can also be set again using the ModbusDev on the right side. The following will use the aforementioned setting to program Flow, read the current X coordinate position of the robot. The user must create a variable to store the X coordinate value in the register.



**IMPORTANT:**

Big-endian is the high byte stored at the lowest memory address and must be checked here.

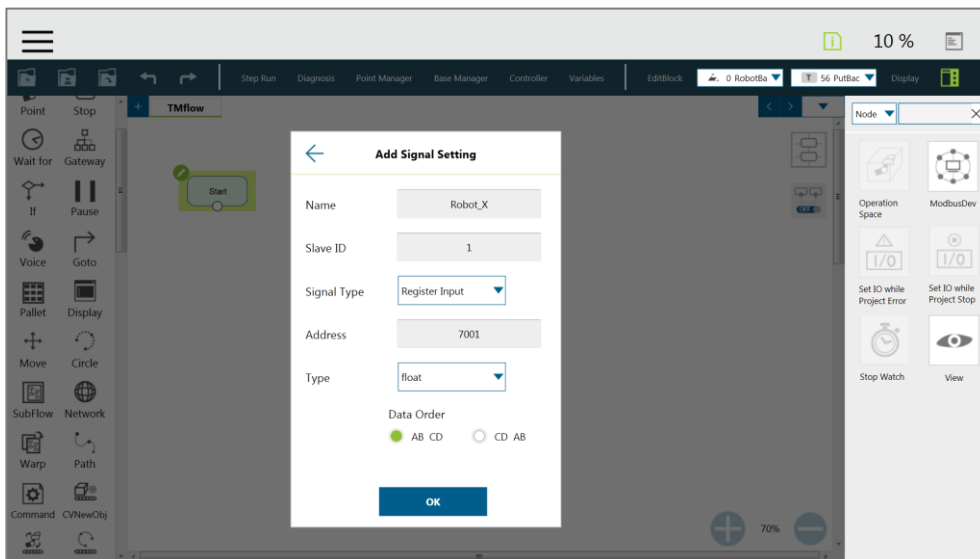

Modbus X Axis Position Parameter Setting

In this example, a float type variable var\_Position\_X is created, so that the variable var\_Position\_X gets the robot's coordinate value in the X direction. And use the Set Node to insert the new variables and the variables obtained by Modbus into the upper text box, and finally use the Display node to verify whether the X coordinate value obtained in the Modbus address is correct.

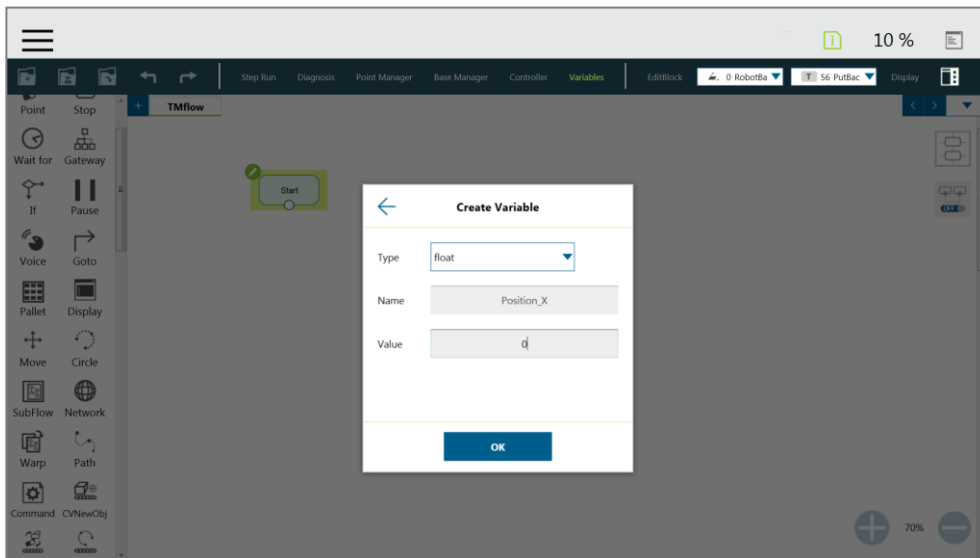

Save the Variable of Modbus Value

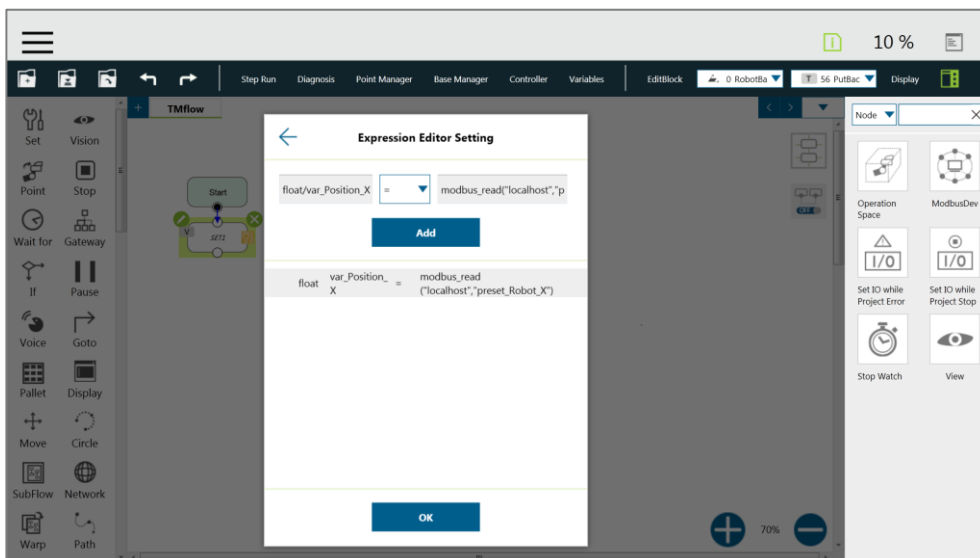

Use the obtained variable of SET node to obtain the value of Modbus

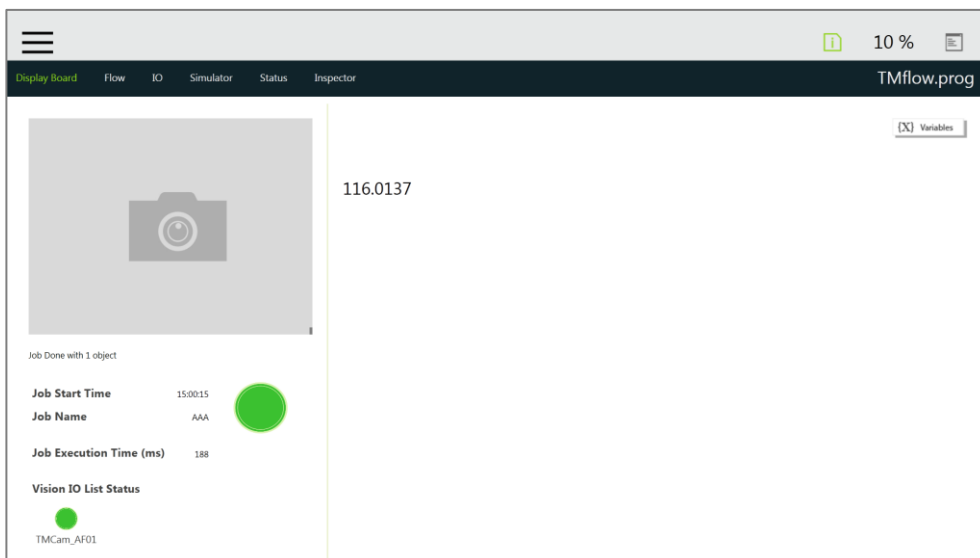

Display displays the value obtained by Modbus

## 12.2 Network

Using Network Node allows the robot to communicate with external devices through RJ45 (TCP/IP). Before that, user should confirm or modify all network parameters at the Network Setting; it is suggested that the external device connected and the robot should be in the same subnetwork.

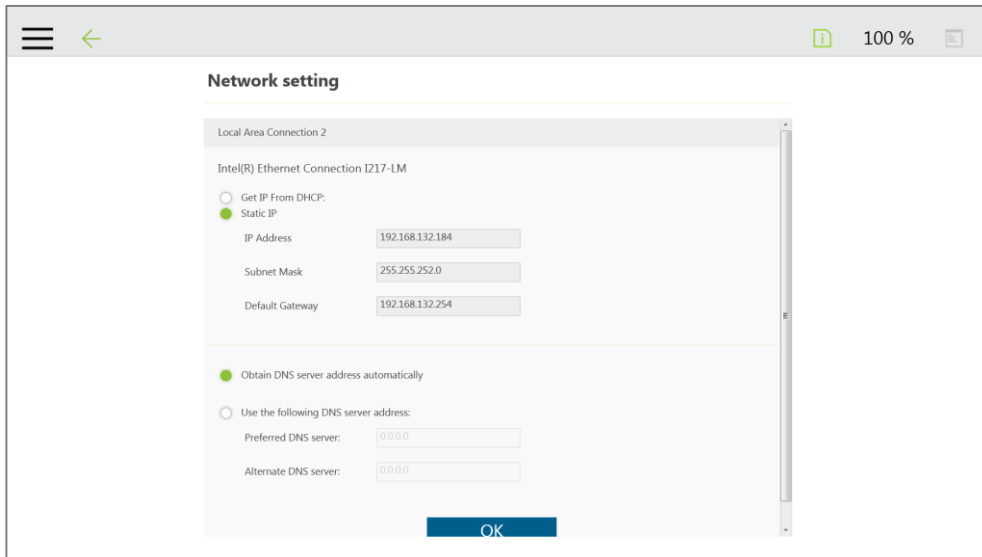

Network Setting

## 12.3 IO

TM Robot provides the user with two formats of digital IO and analog IO. Digital IO controls two state represented by H and L (High/Low), if the output is High represents output voltage of the Control Box is 24V, if Low, then the output voltage will be pulled to GND.

The Control Box configures 16 sets of digital IOs.

The Control Box configures 6 sets of analog IOs. The user can also use the SET node to give the AIO specific voltage (-10V~10V) to complete the job in actual operation.

### 12.3.1 User Defined IO

Using self-defined IO, the user can trigger or read the button on the Robot Stick with external device through the IO ports on the Control Box. After the setting is complete, click the "Save" button in the lower right corner to save the setting.

Control Box Input channel	Meaning	Control Box Output channel	Meaning
9	Stick + button	9	Stick + button
10	Stick - button	10	Stick - button
11	Stick M/A button	11	Stick M/A Mode Switch Button
12	Stick Play button	12	Stick Play Button
13	Stick Stop button	13	Stick Stop Button
		14	System Error Indicator
15	Simulated E-Stop button	15	Simulated E-Stop button

User Defined IO Setting Table

### 12.3.2 External IO

TM Robot provides external IO extension functions, which can be extended by the TM Plug &Play EtherCAT IO extension modules, and the added IO interface port can be call by the controller to test, and to complete the flow programming by the SET node.

### 12.3.3 Status IO

Status IO is that when the project is stopped or in error, the status of the IO is changed to the set value according to these conditions and can be accessed from the Project Function Menu. Click the icon of “Set IO while Project Errors” or “Set IO while Project Stops” to access the setting page.

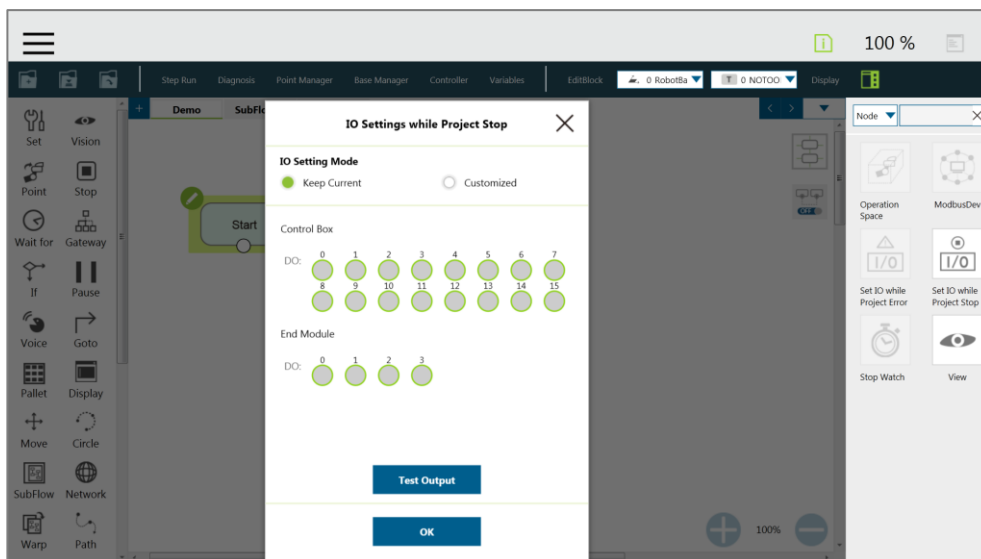
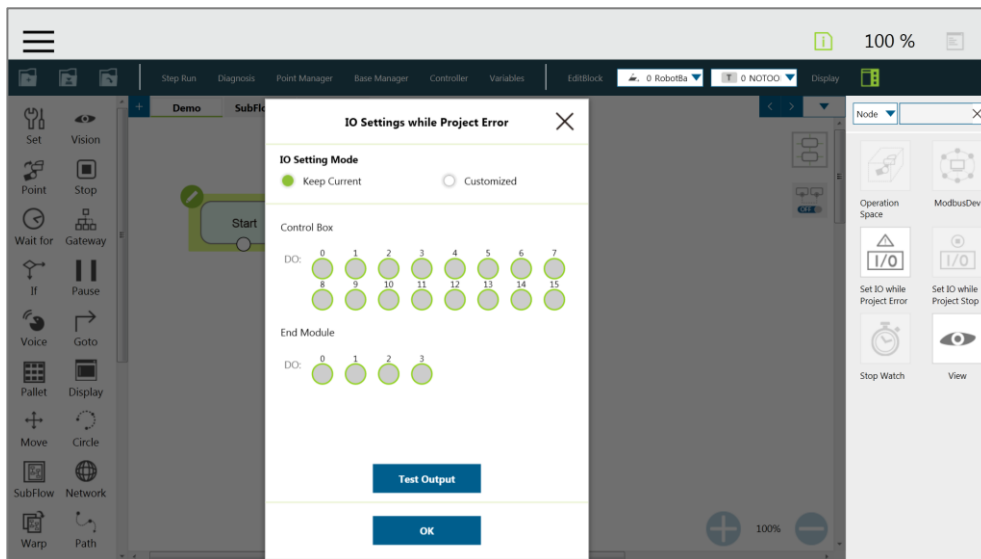

Status IO Setting

## 12.4 Command Node

For special applications, such as reading File, RS232 data, and other functions, the user can import the executable file into the robot and use the Command Node to call the Shadow Server. The Shadow Server should be slave while the Command node in the flow is Master.

There are 2 build-in Shadow Servers, i.e. "File" and "TmComm" which will be introduced in the following section.

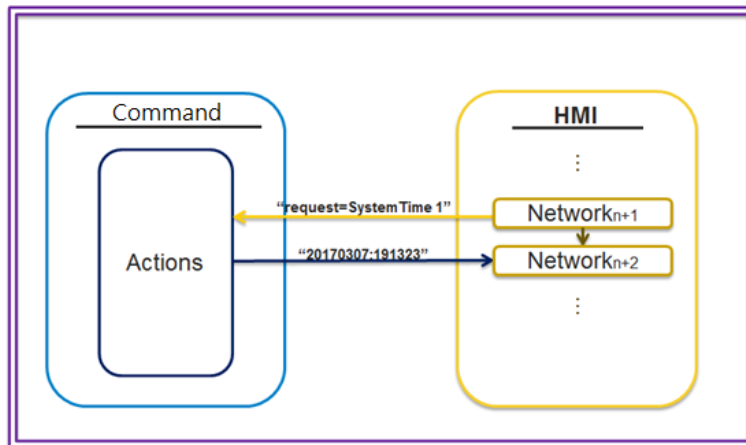

Instruction set communicates with HMI

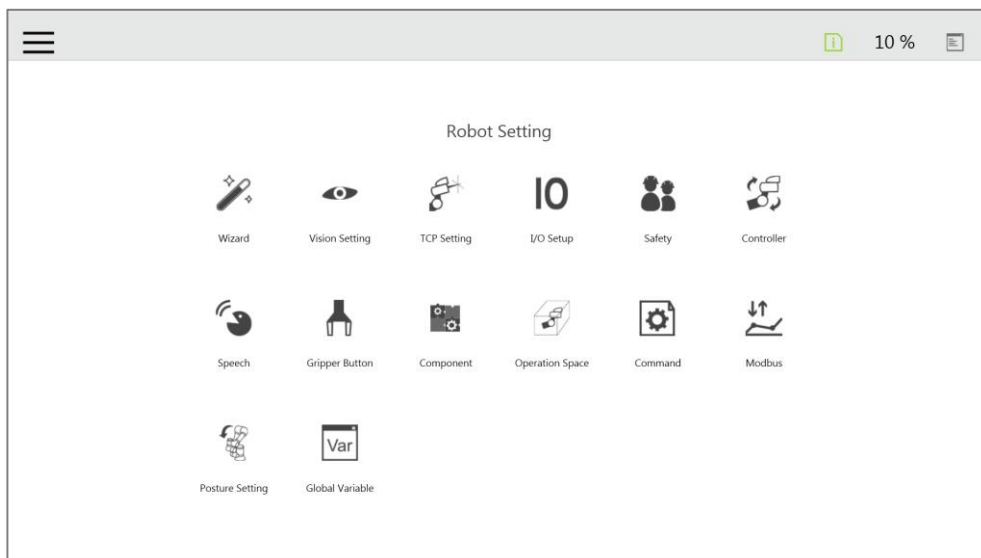

Instruction set access window

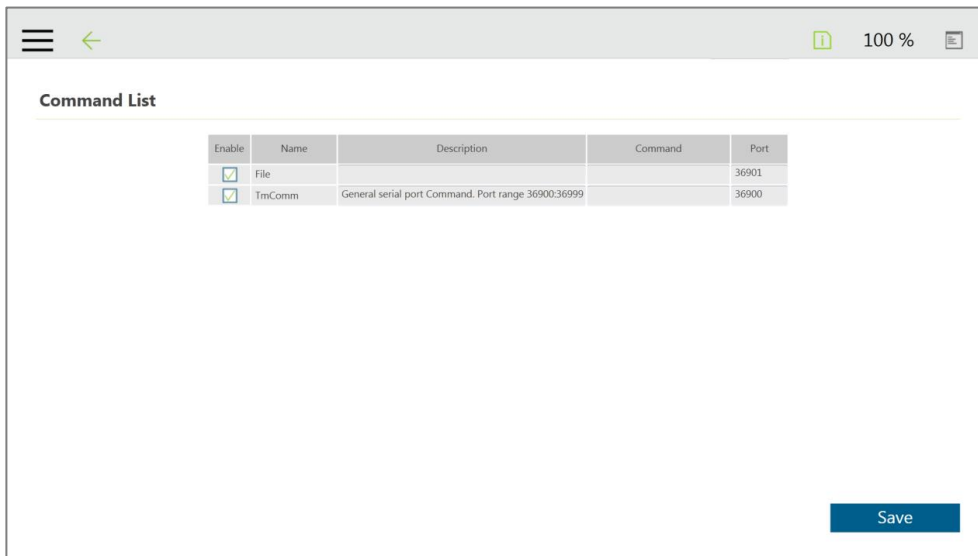

### Enable TmComm Instruction set

#### 12.4.1 TmComm Instruction Set

The TmComm instruction set can read/write strings to the RS232 communication terminal. Before use, it is necessary to ensure that the TmComm in the instruction set is enabled. After confirmed that it is enabled, click Command Port 36900 inside the flow and use the Command node to send corresponding string or variable to this Port, and create a string type variables to accept the returned results.



Tmcomm Instruction set

ComSet	Function	Set the serial port, the following parameters are port name, baudrate, parity, databits, stopbits
	Example	ComSet = 3 9600 n 8 1 3: Set as Com3 9600: baudrate [n   e   m   o   s]: Checking code, n:None, e: Even, M: Mark, o: Odd, s: Space 8: Length of data 1: stop bit
ComOpen	Function	Open the set Serial port, you must first open before you can transfer data
	Example	ComOpen = 3 3: Set as Com3
ComWrite	Function	Write data to the serial port
	Example	ComWrite = 3 John is good boy. 3: Set as Com3 John is good boy.: The first non-blank visible character after serial port number 3 is the data start command
ComRead	Function	Read the data in the current serial port
	Example	ComRead = 3 3: Set as Com3 * This command will read all data of the buffer in the command serial port number and send it back. It is recommended to first check whether there is enough data in the buffer to read, in order to avoid reading the data and not to identify it.
ComReadAfter	Function	Take serial port data and remove the starting specified string
	Example	ComReadAfter = 3 abc 3: Set as Com3 abc: Specified string *This command will read all the data of the buffer in the command serial port number and send it back. It is recommended to check whether there is enough data in the buffer to read, in order to avoid reading the data and unable to read it.
ComClose	Function	Close serial port
	Example	ComClose = 3 3: Set as Com3
ComCheckBuffer	Function	Check the serial port buffer data length
	Example	ComCheckBuffer = 3 eq 5 3: Set as Com3 [eq   le   ge   lt   gt] eq: =, le: <=, ge: >=, lt: <, gt: > 5: Data length Check whether the length of the data in the Com3 buffer is equal to 5 *return: [y   n]
ComClearBuffer	Function	Clear the unread data in the serial port
	Example	ComClearBuffer = 3 3: Set as Com3
ComReadPos	Function	Take the serial port content, return the specified length of data after the specified address
	Example	ComReadPos = 3 15 4 8

		<p>3: Set as Com3 15: Total read length 4: Return data from the fourth character (counting from 0) 8: Specify the length of returned data * Assume that there is information 123456789ABCDEFKKK in the buffer of the current serial port3 The instruction ComReadPos = 3 15 4 8 will read the first 15 (123456789ABCDEF) characters, leaving only KKK three characters in the buffer area. At the same time, the 8-character length data (56789ABC) will be returned from the 4th character.</p>
--	--	--

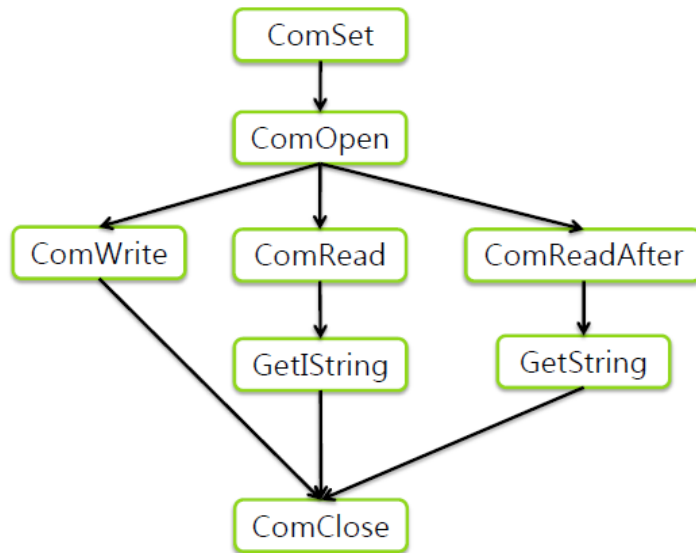

Directive summary flow

In this example, insert the RS-232 into Com1 of the TM Control Box, and communicate with the robot using RS232. After the obtained values have been processed with data analysis, the obtained results will be displayed on the Display Node.

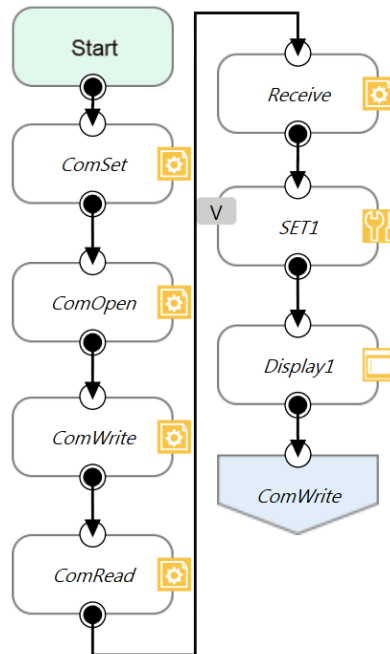

Command node gets RS-232 information

ComSet is used to set the serial port. After completed setting, ComOpen will open the set serial port again. In order to avoid overload, the process can be worked with WaitFor node as the interval, or use the wait time in the Command node as the interval. After ComOpen is opened, if it is not required to send strings additionally to request data, then set the serial port required to read and use the string to receive.

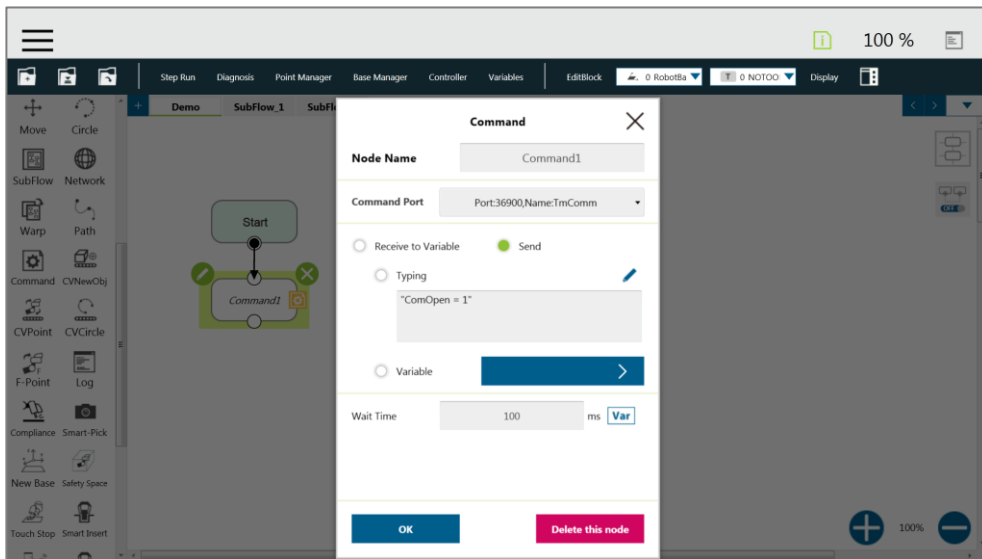
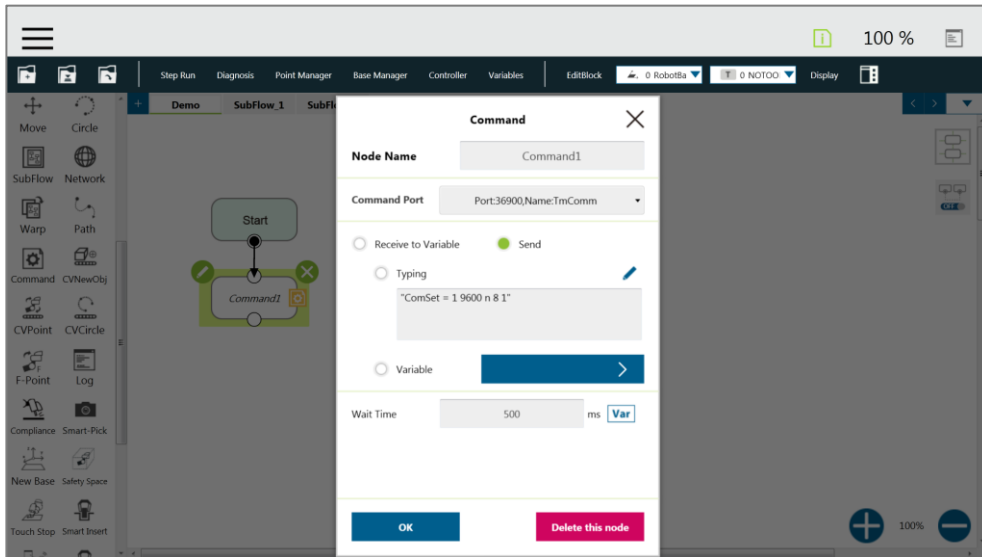

Set and open serial port

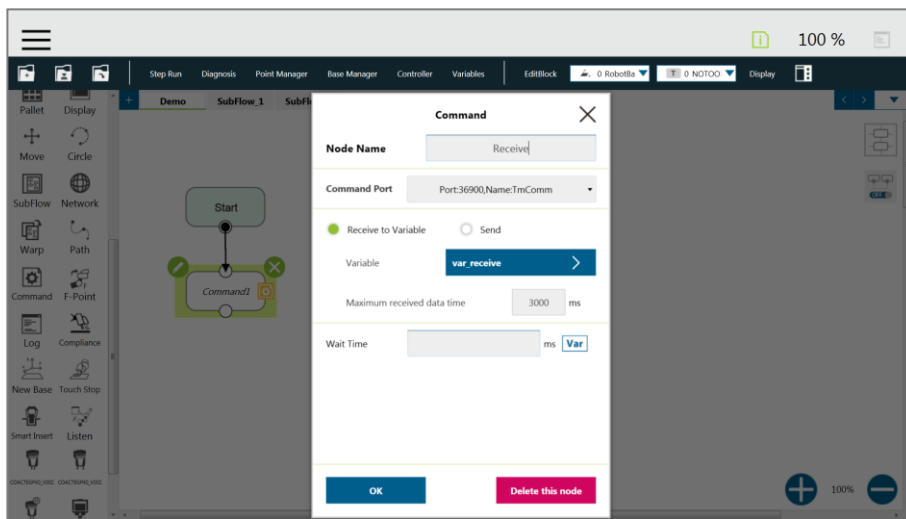
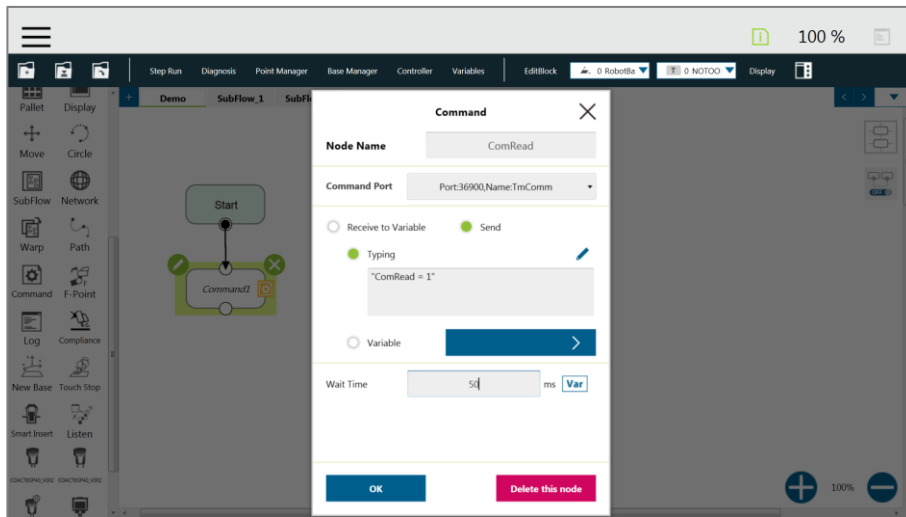

Read data and receive it as variable

At this time, the variable var\_receive will receive a string of characters. The user can conduct string disassembly, type conversion, analysis conversion, etc., according to the protocol of product specification to convert it into a readable state and use it as TMflow variables.

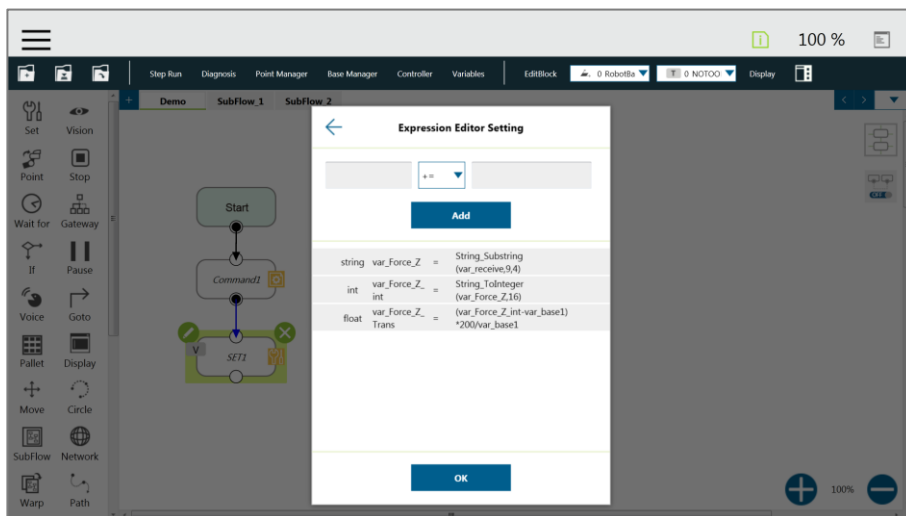

SET Node setting

Finally, the obtained value is displayed on the screen using the Display node, and use the Goto node is to recur and update the value continuously. In the figure above, the first line is the original string obtained from the beginning, the second line is the hexadecimal representation after disassembled the string, the third line is to converted the hexadecimal number into decimal number, and the last line is the analyzed valid value by converting the value obtained by RS-232.

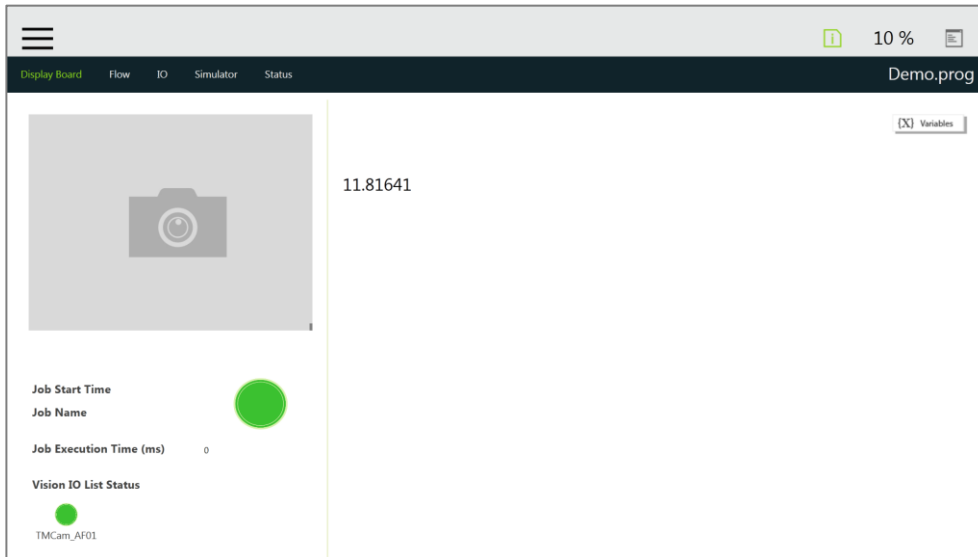

Display node displays the obtained value



**NOTE:**

The function of the Command node, if using the Network node, can also achieve the same purpose by setting the local IP (127.0.0.1).

### 12.4.2 File Command

The File Command provides the user with operations of reading, modifying, and deleting files in the shared folder. The user can communicate with the robot through RJ45. Please confirm that it is enabled from Command List before using. After confirmed, use the Command node to send corresponding string or variable to this Port, and create string type variables to accept the returned results, and complete the flow programming with this concept.

## File Command

<p style="text-align: center;"><b>Write</b></p>	<p style="text-align: center;"><b>Function And Example</b></p>	<p>Add 001.txt to file folder on the remote computer and write test=001  Write = 1 1 \\169.254.158.75\file\001.txt test=001  1: mode, currently fixed at 1  1: Write mode, 1 is to write a new file for writing, 2 is to write an existing file  \\169.254.158.75\file: write target (IP location and folder)  001.txt: text file name to be written  Test=001: What to write  Successful write will return: \\169.254.158.75\file\001.txt  Error return content:  Command length error:illegal parameter  File path error: FILEEMPTY</p>
<p style="text-align: center;"><b>Delete</b></p>	<p style="text-align: center;"><b>Function And Example</b></p>	<p>Delete 001.txt in remote computer file folder  Delete = 1 1 \\169.254.158.75\file\001.txt all  1: mode, currently fixed at 1  1: delete mode, 1 delete file, 2 delete the specified content in the file  \\169.254.158.75\file: Delete target (IP location and folder)  001.txt: text file name to be deleted  All: constant  Example 2: 001.txt in the remote computer's file folder, delete test=001  Delete = 1 2 \\169.254.158.75\file\001.txt test  Success return content:  None  Error return content:  Command length error:illegal parameter  File path error: FILEEMPTY  No deletion specified in the file: Delete Failed</p>
<p style="text-align: center;"><b>Read</b></p>	<p style="text-align: center;"><b>Function And Example</b></p>	<p>Read  Example 1: Reading the contents of 001.txt in the remote computer's file folder  (example: test=001)  Read = 1 \\169.254.158.75\file\001.txt test  1: Read variable value  \\169.254.158.75\file: Read target (IP location and folder)  001.txt: text file name to read  Test: content to read  Success return content:  Variable content, such as example 1 will return 001  Error return content:  Command length error:illegal parameter  File path error: FILEEMPTY  No specified content read in file: KEYWORDEEMPTY</p>

<p style="text-align: center;"><b>Search</b></p>	<p style="text-align: center;"><b>Function And Example</b></p>	<p>Search for the existence of 001.txt in the remote computer file folder</p> <p>Search<sup>^=^1^</sup>\\169.254.158.75\file\001.txt</p> <p>Definitions:</p> <p>1: search file</p> <p>\\169.254.158.75\file: Search target (IP location and folder)</p> <p>001.txt: text file name to search for</p> <p>Success return content:</p> <p>File exist</p> <p>Error return content:</p> <p>File path error or file does not exist: FILEEMPTY</p>
--	--	---



The method of using File Command, using write/delete as an example: In Command node, Send Input write instruction, then receives the Write return result through the new variable. In this example, a string type variable, receive, is added. Use the Command1 node to create a text file with filename of TM\_Robot in the location of 168.254.158.74. The text file content is text=001, and in Command2, use receive variable to receive File Command for the return value of Command1, finally, use the Display node to display the received value receive on the screen.

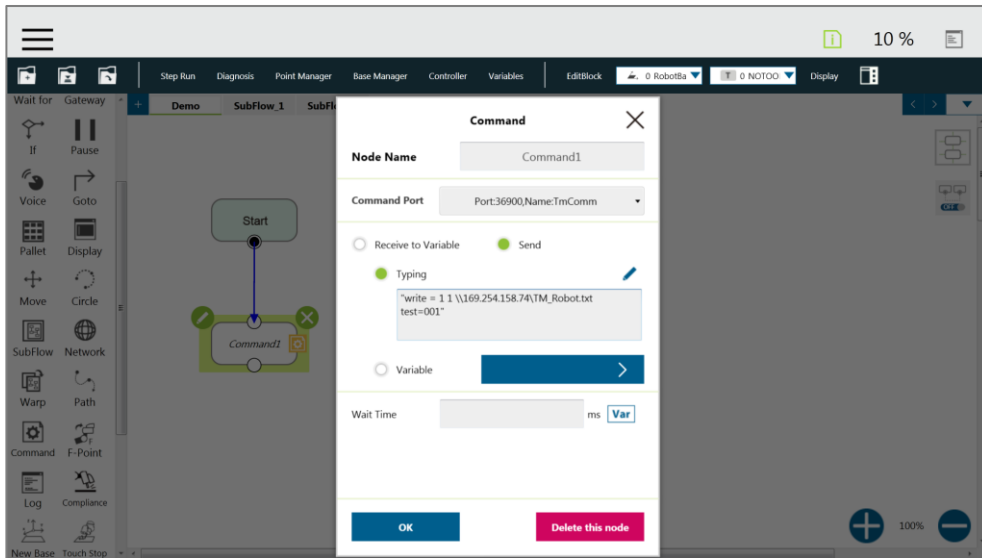

Remote add notepad and write information

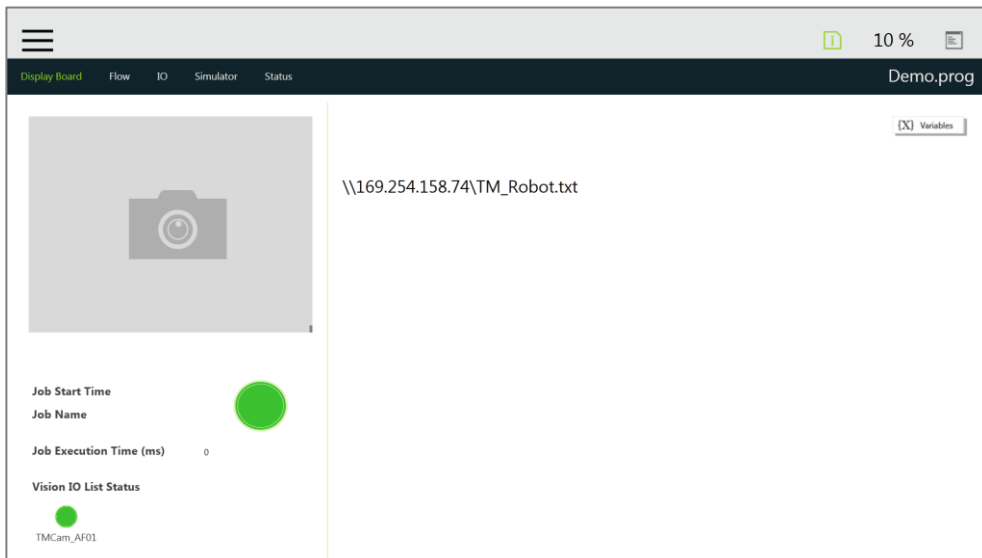

Display node displays received variables

In the example of figure below, In Command1, send delete command to delete text file with filename of TM\_Robot in the location of 168.254.158.74.

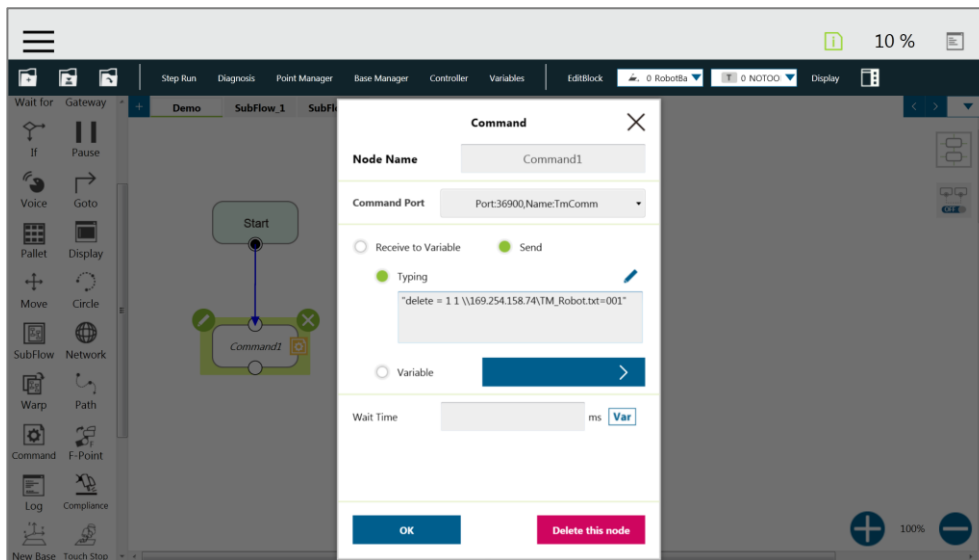

Remote delete notepad file

**Note**

**NOTE:**

The function of the Command Node, if using the Network Node, the local IP (127.0.0.1) can be set to achieve the same purpose.

## 12.5 Log Node

The Client end can set up the network to create shared folder and communicate with the robot through the LAN. In the project, the set variables and strings can be saved to this shared folder with this Node. The customers can use their own computers to view the history messages stored in the Log Node in the Shared Folder. As shown in the figure below, the robot motion is programmed in the main flow, and the Thread constantly takes its angle information using Modbus to write the angle information into the text.

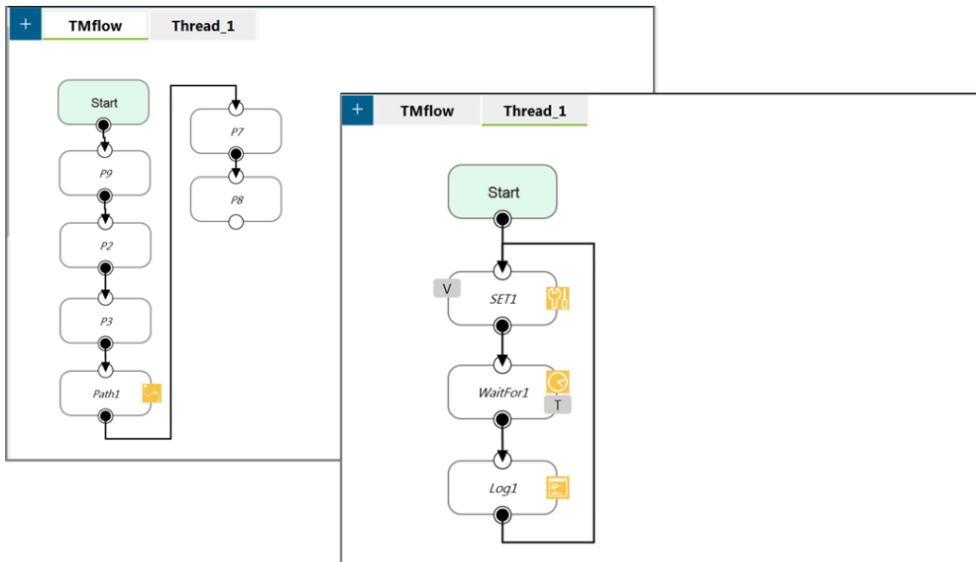

Log node gets the current angle

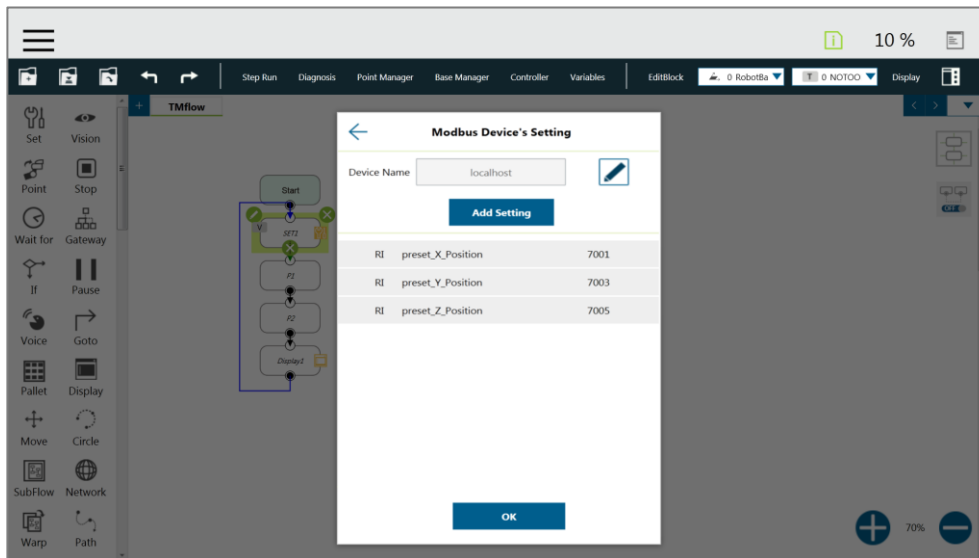

Modbus Setting

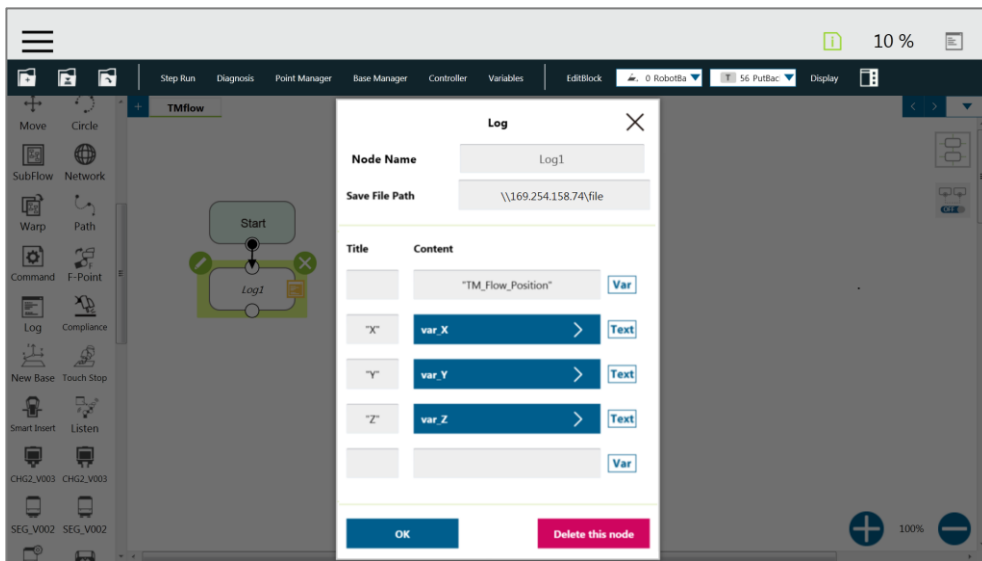
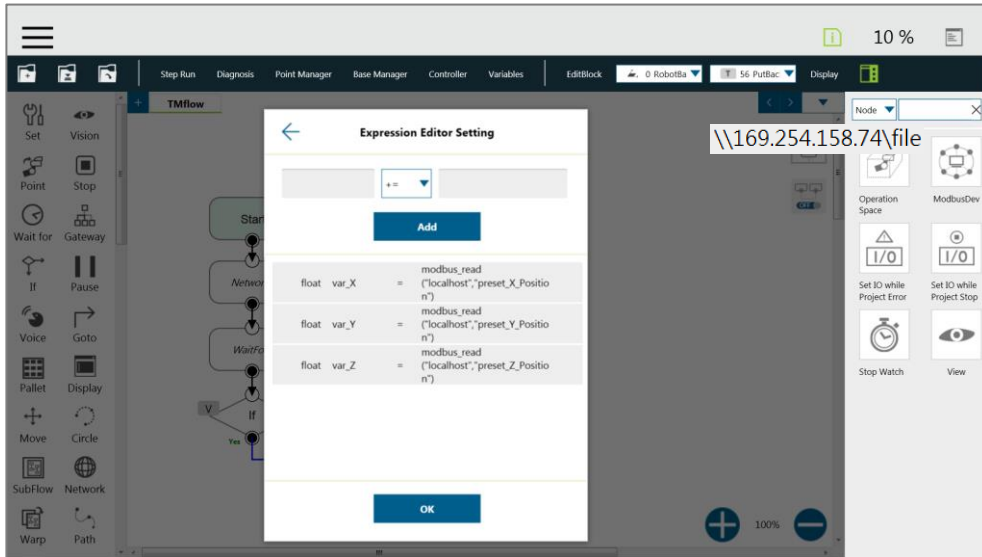

Log of Thread Page, SET Node Settings

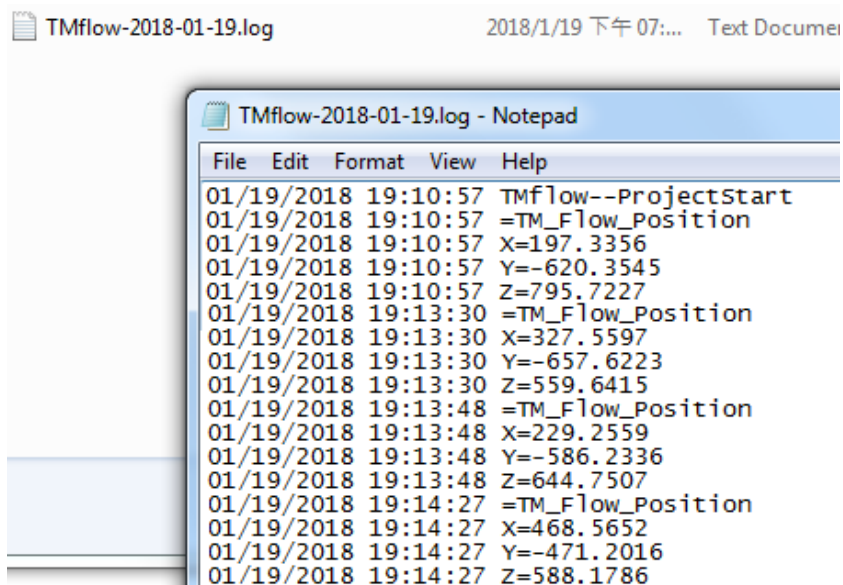

Node Text Example

## 12.6 Display Node

The function of Display Node is to display the specified variable or string on the screen of display according to the format specified by the user. For example, it can be used to display the state of variable, the value obtained by serial port, the parameters of robot, or the result of running. In addition, the Display area can change the background color and text color, the user can change the color according to the results, and seven colors are supported with red, green, blue, yellow, black, white and gray.

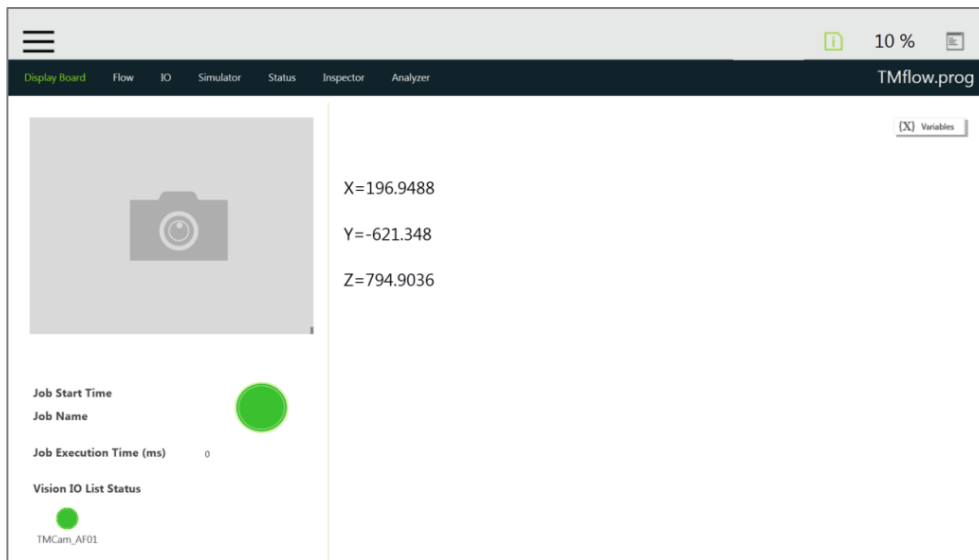

Display displays the robot's position

## 12.7 Voice Node

When running through Voice Node, the speakers, headphones and other devices can be used to broadcast the set of text or variables. According to different usage, it can be divided into talking while moving (Speak and Move), or moving after finishing talking (Speak, then Move), detailed syntax is the same as that of the Display Node.

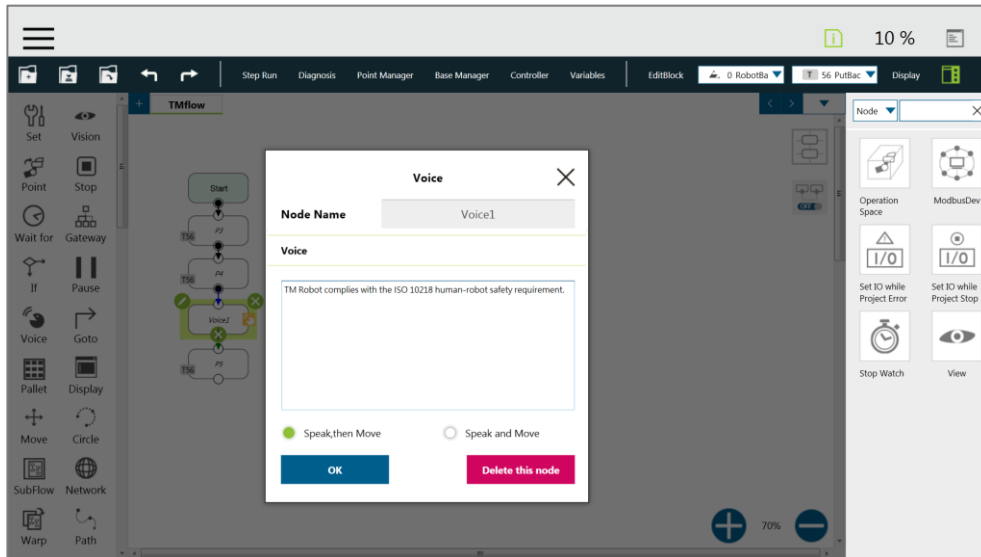

Voice node in TMflow application

For example, user can create a string type variable Hello, and input the combination of variable and string in the Voice node. At this time, the external broadcast device will say "Hello World" according to the setting, but be careful that if a space is not added in front of World, then it will become "HelloWorld", the result with error will be different from the expected result.



### IMPORTANT:

If using "Speak and Move", the speech will be saved into a buffer and deleted only if the system finish speaking it. That means, if the Voice is used in a Thread with a quick loop, the buffer size will increase insanely, that the robot might keep speaking without an end.

## 13. Component

Component is an independent software package provided for the robot. For Plug&Play supported items, the user does not need to write additional programs, and does not need to read the manuals of both parties before integrating, only need to import the software package and can use in TMflow directly. After downloaded the software package, place the folder with filename of TM\_Export in the root directory of the USB flash drive. The name of the USB flash drive must be TMROBOT. After inserted the USB into the robot's Control Box, the software package can be exported/imported into the robot on the robot system page.

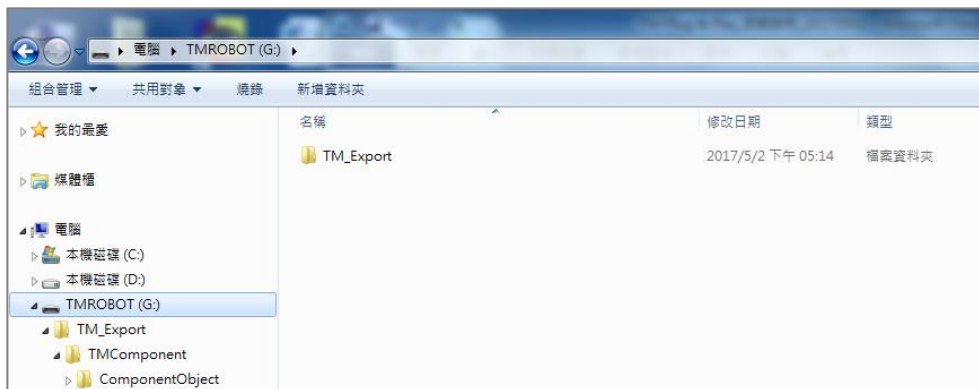

TMROBOT Flash Drive Schematic Diagram

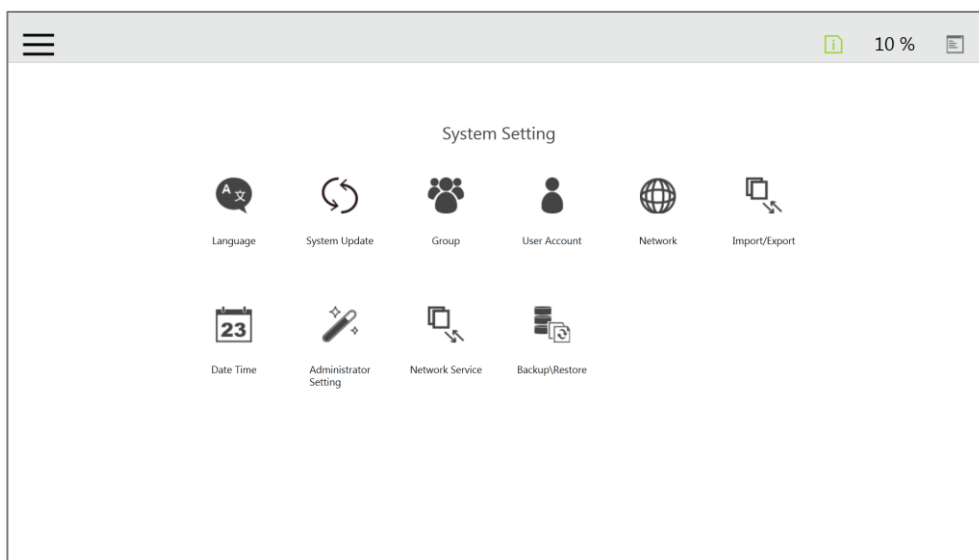

Import / Export Page Access Window

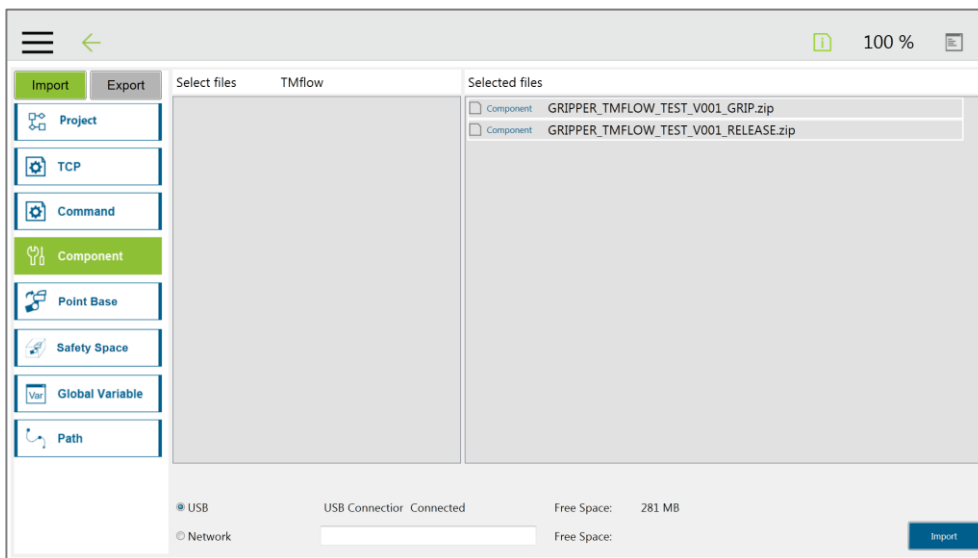

Import Component

After imported the software package, the imported software package needs to be enabled in the Robot Setting page. After enabled, the software package imported in each project will be added to the left side of TMflow. The user can use it directly after dragged from the left side.

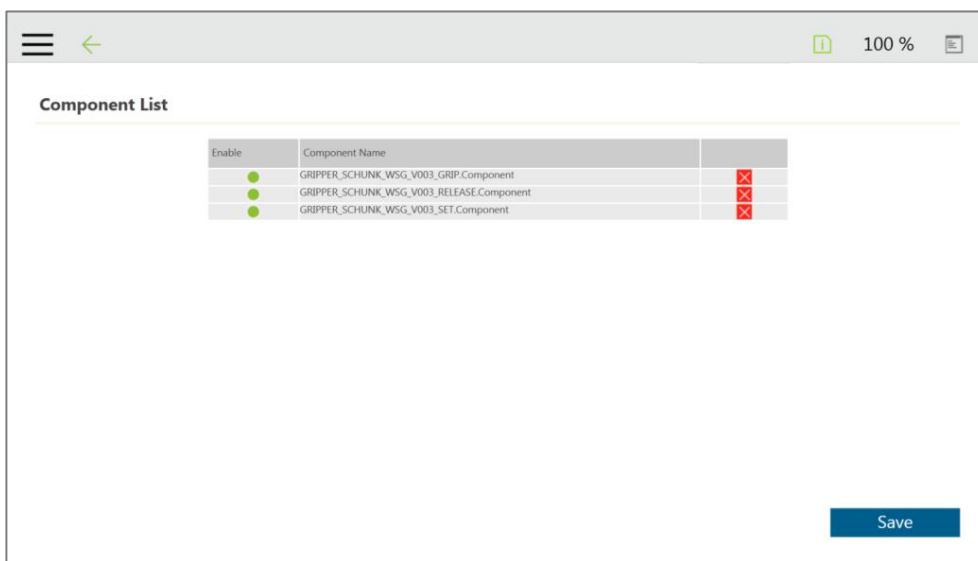

Robot Setting Page Component

The setting parameters of each software package are not the same. The instructions in the upper right corner of the software package node can be clicked to view the parameters need to be set and the method of usage.





### IMPORTANT:

Some of the Component needs to use the Command to communicate with the robot. When this type of Component in imported, the corresponding Command will be added in the Command list. Please confirm whether the corresponding instruction set is enabled.

The robot provides a simpler process programming method for the gripper-type software package. On the robot setting page, click the Gripper button to set the job triggered by the Gripper button at the End Module. The concept is when clicking the Gripper button, a set of Component is added in the flow and execute once, and two Components are used in sequence (remember that some of the grippers need to be executed with SET Component before can be used). In practical applications, the robot uses the FREE Button, working with the buttons of End Module record gripper and point, to complete flow programming without TMflow control.

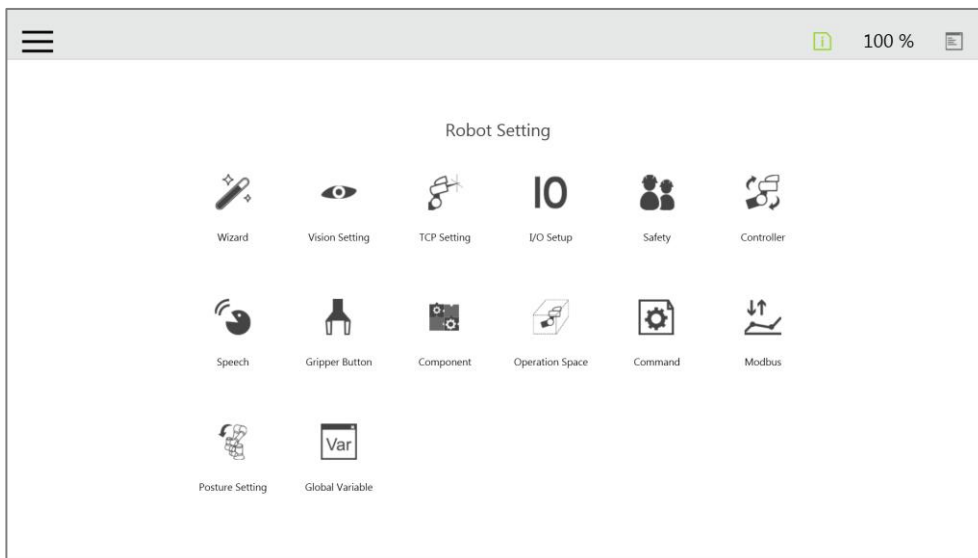

Gripper Setting Page to enter the Window

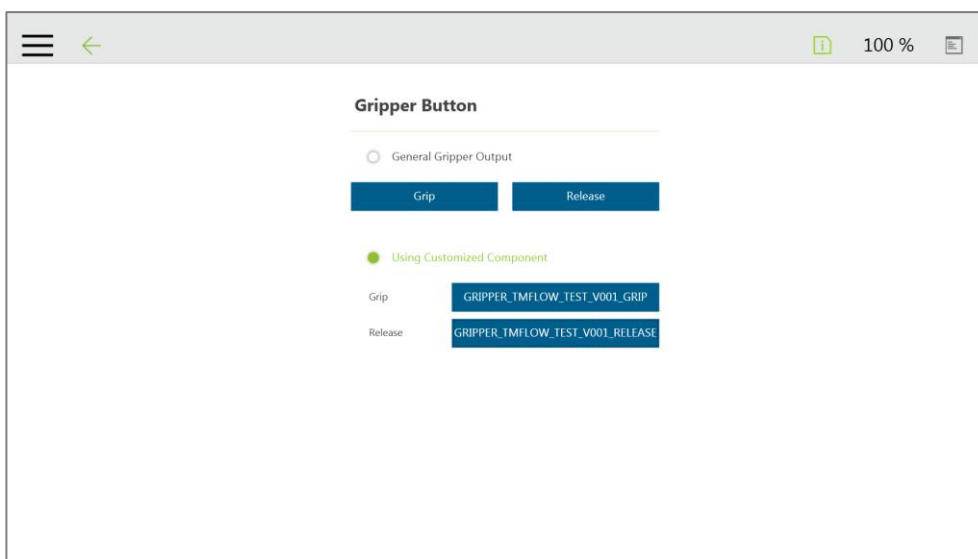

Gripper Button Setting Page

## 14. Force Related Node

### 14.1 Compliance node

The Compliance node can set the force limit when the robot moves along a single Base. This setting can be used for various applications of collision testing, object assembly, and object searching. The user can determine the direction of robot motion based on the Current Base or Tool Base.

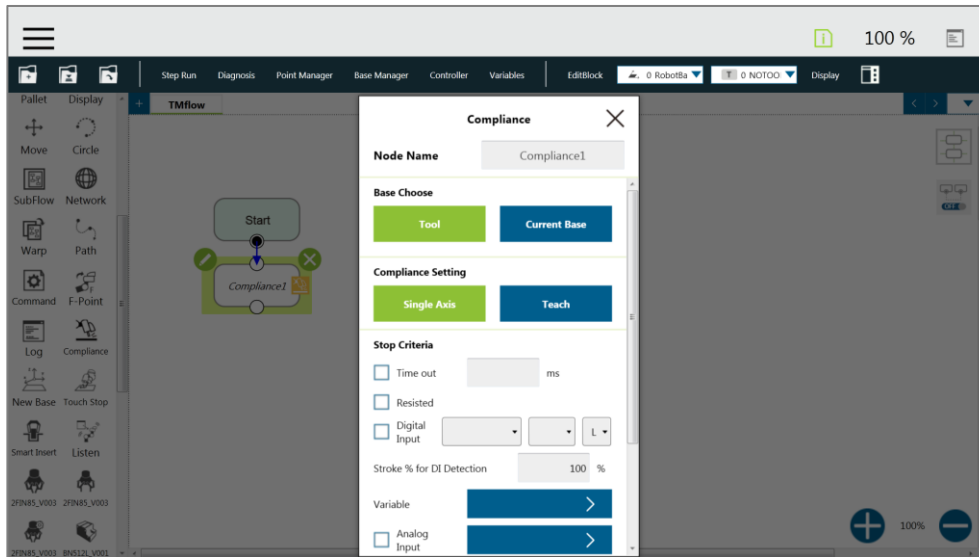

Compliance Node

- Base setting: Move according to the Tool Base or Current Base
- Robot movement direction setting: Set the robot to move along a certain axis, or choose to use manual teaching method
- Stop Condition Setting:
  - Timeout: This node will be release if the set time is reached before or while running the job
  - External resistance detection: When the resistance is sensed, the speed at the robot end is close to zero, and the node is released
  - Digital Input: Set a digital input signal, this node is released when the signal is met
  - Stroke % for DIO Detection: When the moving distance exceeds the relative percentage, there will be different Int values output to the variable to perform judgment
  - Variable: Set Stroke % for DIO Detection Receiving Variable
  - Analog Input: Set an analog input signal, when met, this node is released

The motion settings of Compliance Node can be divided into two types: single axis and teaching. Refer to the example description in this Section for single axis. For the teaching, the Compliance node can choose to teach with line direction or rotation direction. The user can use the two points of teaching to perform relative movement to complete the assembly, collision and other jobs, after complete the setting of relevant parameters, the user can specify the speed of motion and other additional stop conditions in the motion mode, to ensure that the tool will not be damaged. In the Compliance mode, the safety settings still function.

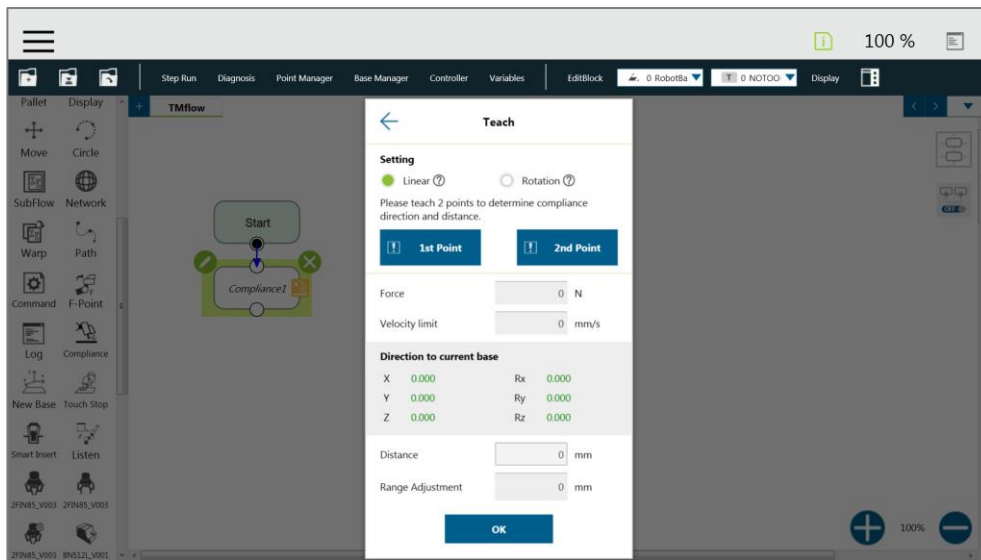

Compliance node teaching setting

- Teaching setting: teach in a line direction or rotation direction
- Teaching Point: Set two points teach and calculate the direction and distance. These two points are not recording the actual points, the movement method is relative movement similar to the Move node.
- Range Adjustment: Provide the user with direct adjustment of distance or angle in the original direction without resetting the teaching point

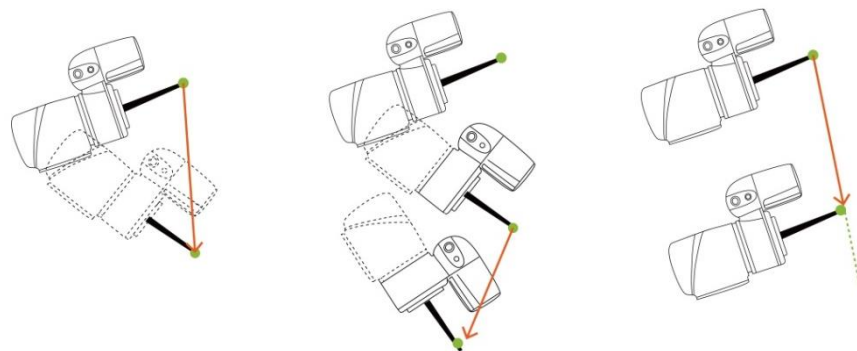

Line Direction

## Rotation

Only orientation difference between the 2 teach points is used to perform a relative compliance motion from the point entering the node.

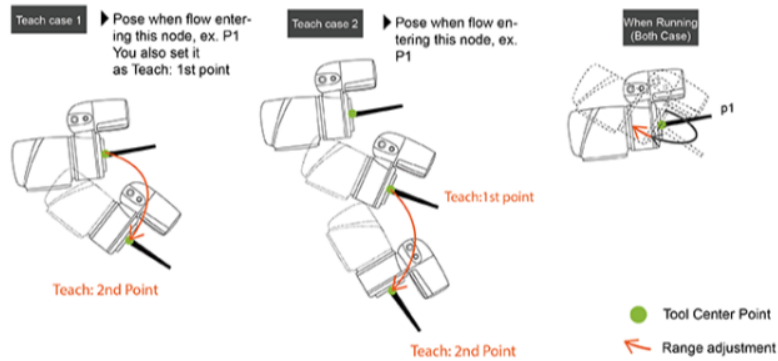

## Rotation Direction

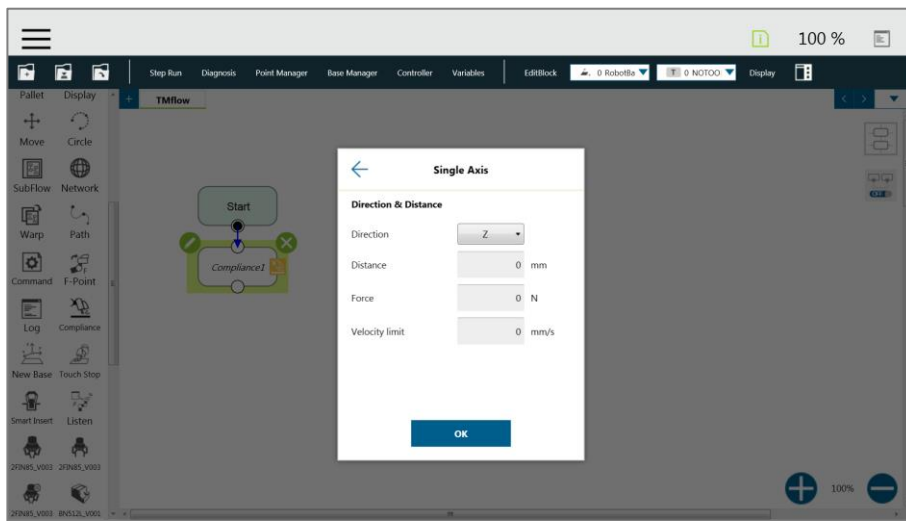

Compliance node single axis setting

The user can pre-program the solution for any possible situation according to the result of variable returned by the Compliance node, and coordinated with the IF node.

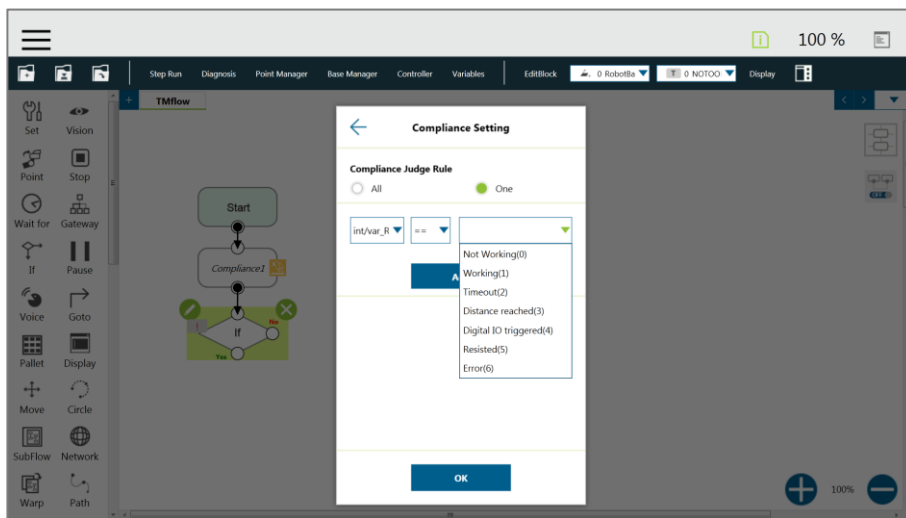

Compliance Variable Selection

## 14.2 TouchStop Node

### 14.2.1 TouchStop- Compliance

Capable of setting the force limit when the robot moves along a single Base. This setting can be used for various applications of object searching, creating a new Base, and recording the current coordinate value of triggering TouchStop.

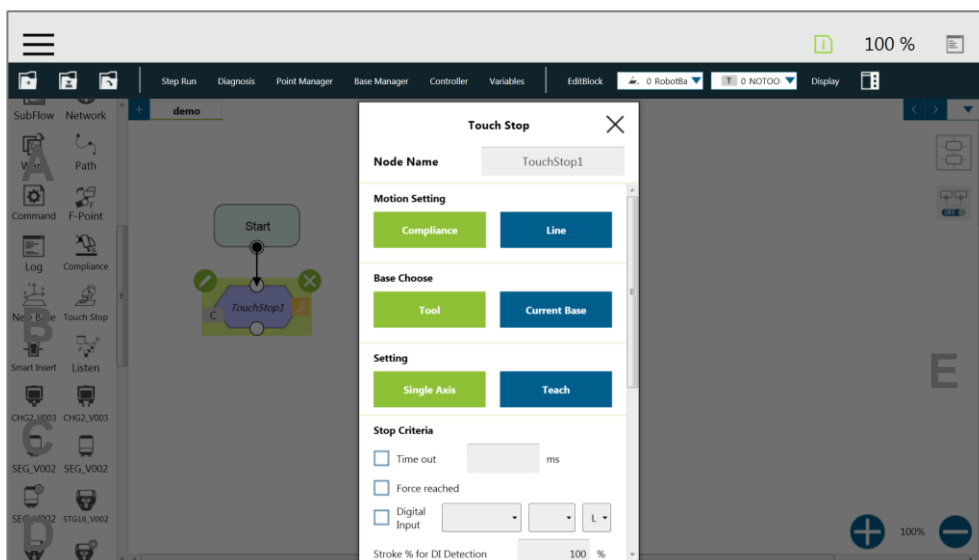

TouchStop-Compliance Settings

- Motion Mode Setting: Move using Compliance or Line method
- Base Setting: Move according to Tool Base or Current Base
- Robot movement direction setting: Set the robot to move along a certain axis, or choose to use manual teaching method
- Stop Condition Setting:
  - Timeout: Set the length of time to stop and release this node
  - External resistance detection: When the resistance is sensed, the speed at the robot end is close to zero, and the node is released
  - Digital IO: Set a digital input signal as the stop and release of this node
  - Stroke % for DIO Detection: When the walking distance exceeds the relative percentage, there will be different Int values output to the variable to perform judgment
  - Variable: Set Stroke % for DIO Detection Receiving Variable
  - Analog IO: Set an analog input signal as the stop and release of this node
- Record the point of stop position: The stop position or trigger position can be selected, when the robot takes over at the above stop condition, it can set the self defined point name, and recording the current robot position at this time.

## 14.2.2 TouchStop- Line

This function is designed to set the robot's line movement along a single Base, and working with the signal to stop the robot motion. This setting can be used for the application of external sensor on external tool and record the position. The user can determine the direction of robot motion based on the Current Base or Tool Base.

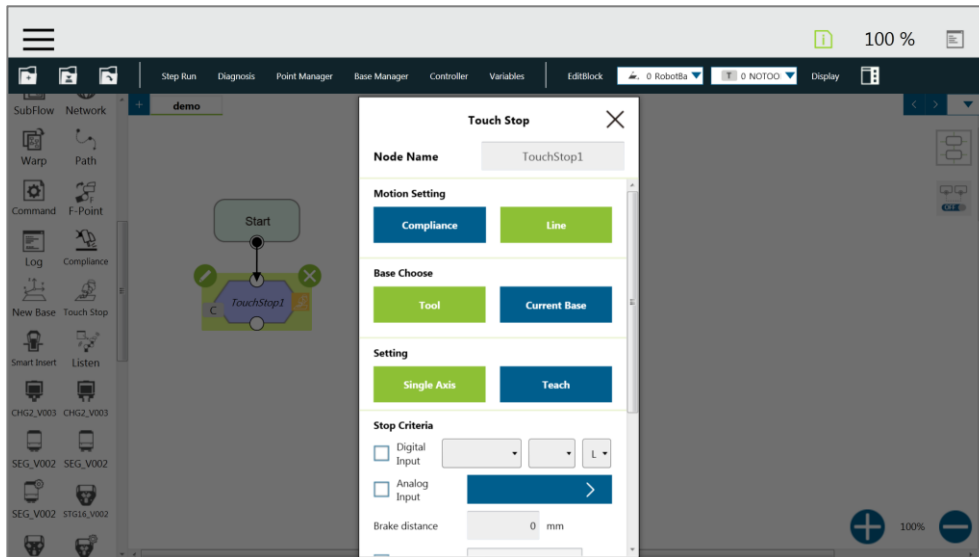

TouchStop-Line Settings

- Motion Mode Setting: Move using Compliance or Line method
- Base Setting: Move according to Tool Base or Current Base
- Robot movement direction setting: Set the arm to move along an axis, or choose to use the teaching method
- Stop Condition Setting:
  - Digital IO: Set a digital Input signal as the stop and release of this node.
  - Analog IO: Set an analog Input signal as the stop and release of this node.
  - Braking distance: Set the distance of motor braking. If the braking distance is set to 80mm, the motor will brake and stop after the robot end from the initial position to after the running of 80mm.
- Record the point of stop position: The stop position or trigger position can be selected, when the robot takes over at the above stop condition, it can set the self defined point name, and recording the current robot position at this time.

## 14.3 SmartInsert Node

The SmartInsert Node allows the robot to perform assembly/pushing jobs. The smart design enables difficult object assembly/pushing jobs to be completed through simple and quick setting. The pushing action of SmartInsert Node can be divided into three steps: Approaching, Searching, and Pushing. This Node needs to be worked with the cooperating force sensor in TM Plug&Play for use. The following describes the three steps of pushing.

### 14.3.1 Approaching

#### 14.3.1.1 Approaching principle description

Before using the Smart Insert node, the user shall place the inserting object as close to the assembly as possible. In the Approaching step, the robot will move toward the z axis direction of the Tool Base until the force sensor detects 5 Newtons (N) of resistance, to be judged as in contact with the inserting object.

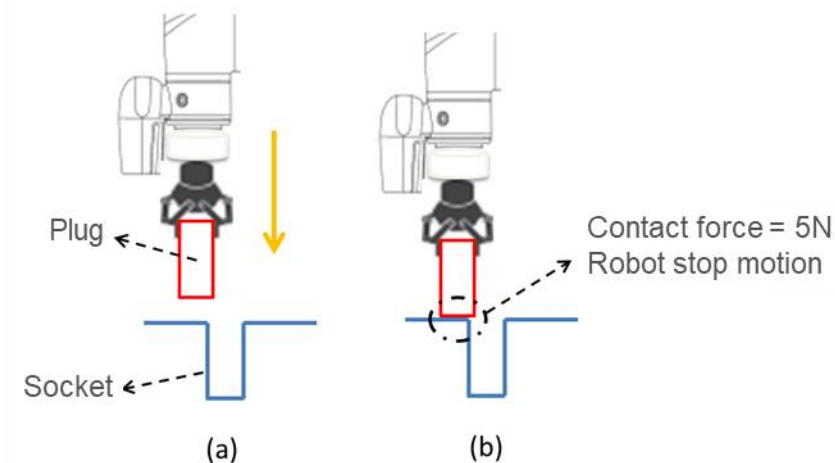

(a) Try to make the robot as close to the inserting object as possible

(b) When the contact force is 5 Newtons, the robotic arm ends the Approaching step



#### **IMPORTANT:**

Since the contact force needs to reach 5 Newtons, the Approaching step will end. The user needs to confirm that the inserting object and object to be inserted are able to withstand at least 5 Newtons of force, so as not to damage the product.

### 14.3.1.2 Approaching parameters setting

The Approaching of SmartInsert Node provides three setting parameters (Approaching Speed, Moving Distance Limit, Time Out). Among them, the speed range of approaching speed is 0.5-10mm/s, and the maximum moving distance limit range is 1-100mm, and the timeout time can be set between 1-20 seconds. It is worth noting that the approaching direction of the Smart Insert Node is the Z axis direction of the Tool Base.

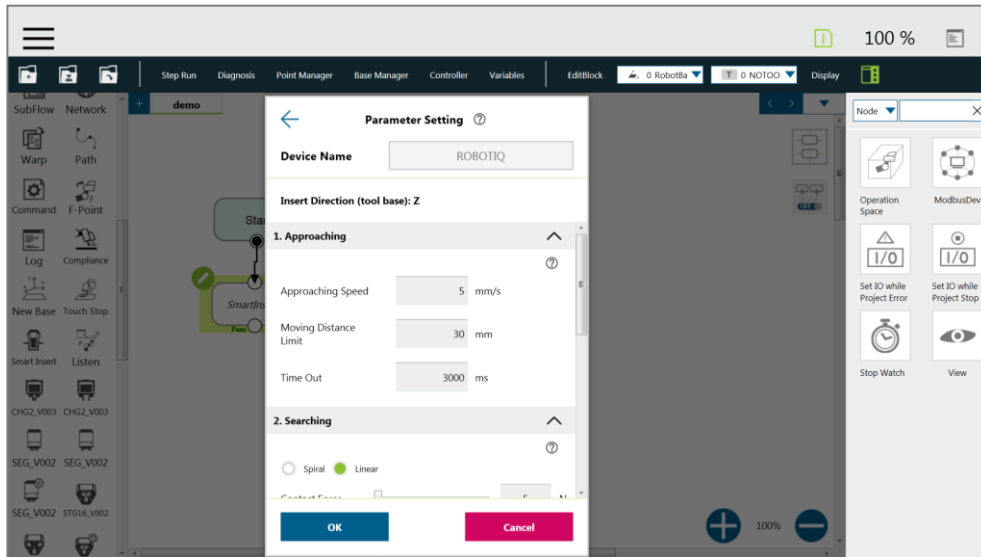

Approaching Parameter Setting

### 14.3.2 Searching

After ended the Approaching step, enters the Searching Stage. Searching can be divided into two strategies of Spiral and Line. The figure below is the motion method of the Spiral strategy. This searching strategy uses the Approaching contact point as the center of the circle, that is, the contact stop point between the inserting object and the object to be inserted, and searches outward in a spiral motion method until the stop condition is met. If the user selects Line method for searching, the robotic arm will follow the search axis set by the user to perform Line search until the stop condition is met, as shown in the figure. Regardless it is Spiral or Line searching method, the robotic arm exerts a downward fixed force Tool Z Axis direction during the search.

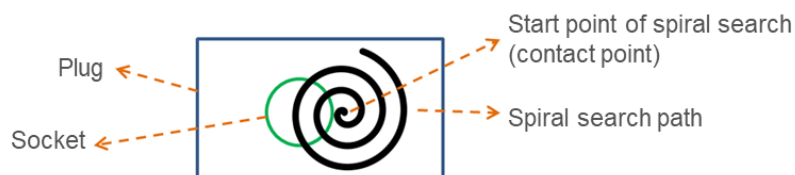

The Spiral searching method starts from the contact point and spirals outward to search for the inserting target



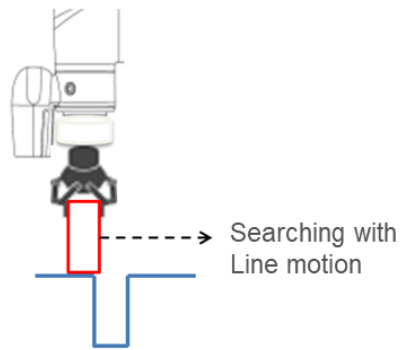

The robotic arm will search in the set direction and move in a straight line

The Searching stop condition can be divided into "Completed Searching" and "Stop Searching", of which Stopping Searching also is that the inserting point cannot be found within the searching condition, such as the searching time is too long, the searching distance is too long, etc. On the other hand, if after the inserting object entered the inserting point, the combined force of X-Y Plane is greater than 5 Newtons (N), and the Z Axis does not have contact force which is 0, then it is judged as Completed Searching, and enter the final Inserting Stage.

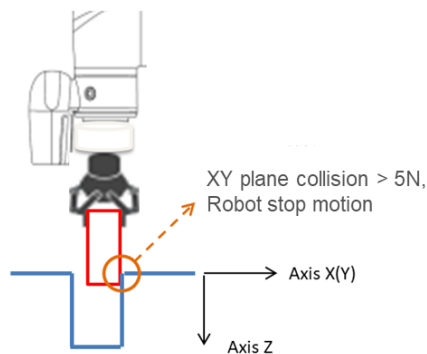

When the XY combined force of collision is greater than 5 Newtons, it is judged as Completed Searching

### 14.3.2.1 Searching Parameter Setting

In the operation interface, the user can select the Spiral or Line method for searching. The following describes the parameter settings for each searching mode. In Spiral searching, the Searching Radius, Circling Frequency, Height Tolerance, and Time Out need to be set. The following is definition explanation of each setting condition as shown in the Table below.

Spiral Searching Function Setting Parameters Definition

Terminology	Definition	Setting Range
Searching Radius	Maximum moving radius of spiral searching motion	1-30mm
Circling Frequency	Spiral search process, the number of circling per second	0.5-1.5Hz
Height Tolerance	The maximum movement height of the robot in Tool Base Z axis	1-100mm
Timeout	Allowed searching time	1-20sec

It is worth mentioning that during the spiral searching process, the robotic arm may walk out of the boundary of the inserting object, and misjudge it as "Inserting Point Found". Therefore, setting the Height Tolerance can prevent the occurrence of misjudgment.

**Note**

**NOTE:**

In general, if the geometry shape of the inserting object is circular, such as positioning pins, it is recommended to use the spiral searching method; if the geometry shape of the insert object is rectangular, such as SDRAM, it is recommended to set the searching method to Line.

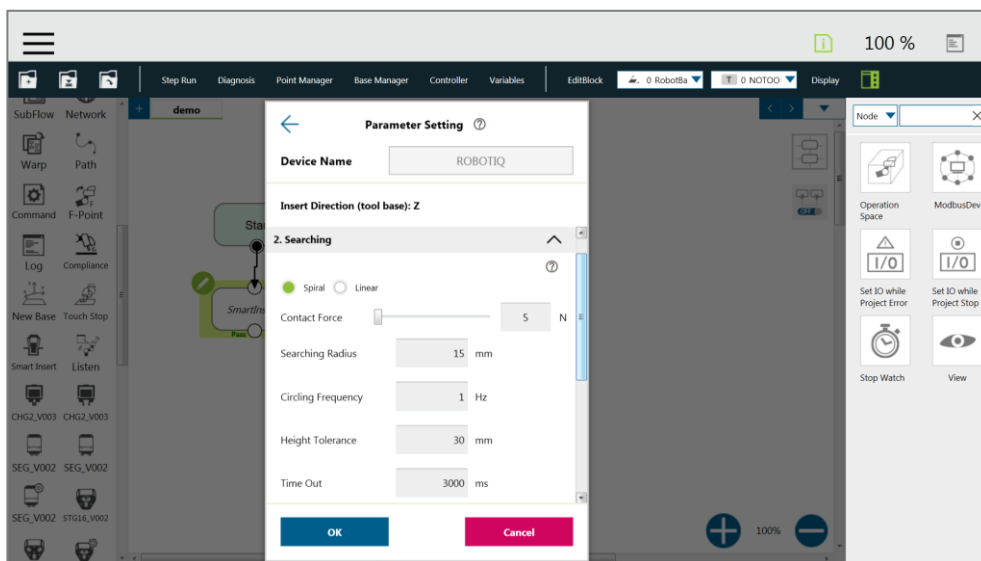

Spiral searching parameter setting interface

Line searching setting, its parameter setting interface is shown in the figure below. Different from the spiral searching, the line searching can set the size of contact force size of the Tool Base Z axis and the line searching direction (Searching Direction). The line searching parameters are defined as shown in the Table below.

Line searching function setting parameter definition

Terminology	definition	Setting Range
Contact Force	Tool Base Z-axis contact force	5-150N
Searching Direction	Select Tool Base X or Y axis search direction	-----
Searching Speed	Moving speed of line searching	0.5-10mm/s
Maximum searching distance	Allowed maximum moving distance of searching	1-100mm
Timeout	Allowed Searching Time	1-20sec

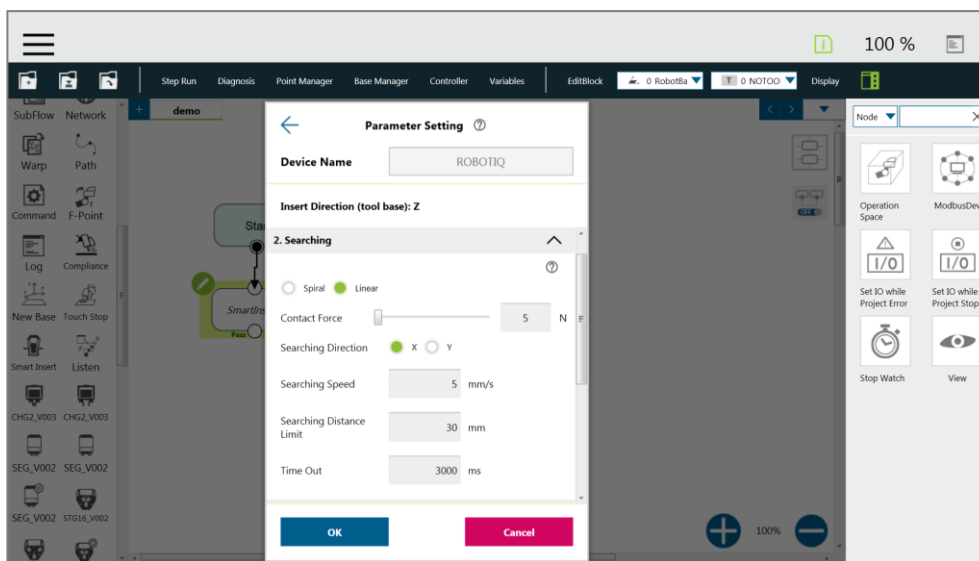

Line searching parameter setting interface

### 14.3.3 Pushing

#### 14.3.3.1 Pushing Principle Description

After completed the Searching steps, the pushing has been aligned to the pushing point. In the pushing process, the robotic arm will move toward to Z-axis direction until reached the stop condition, such as detected the Z-axis contact force or the stroke distance of pushing is met. If X, Y, RX, RY, and RZ detect external force resistance, the Smart Insert node will automatically move smoothly in the opposite direction of the collision to avoid causing collision interference in the pushing process.

#### 14.3.3.2 Pushing Parameter Setting

Parameter setting of Pushing is similar to the Line Searching. The user can set the Contact Force, Pushing Speed, Moving Distance Limit and Time Out of the Pushing process. The definition and setting of each parameter is shown in the Table below.

Pushing function setting parameter definition

Terminology	Definition	Setting Range
Contact Force	Tool Base Z-axis contact force	5-150N
Searching Speed	Moving speed of line searching	0.5-10mm/s
Maximum moving distance	Allowed maximum moving distance	1-100mm
Timeout	Allowed searching time	1-20sec

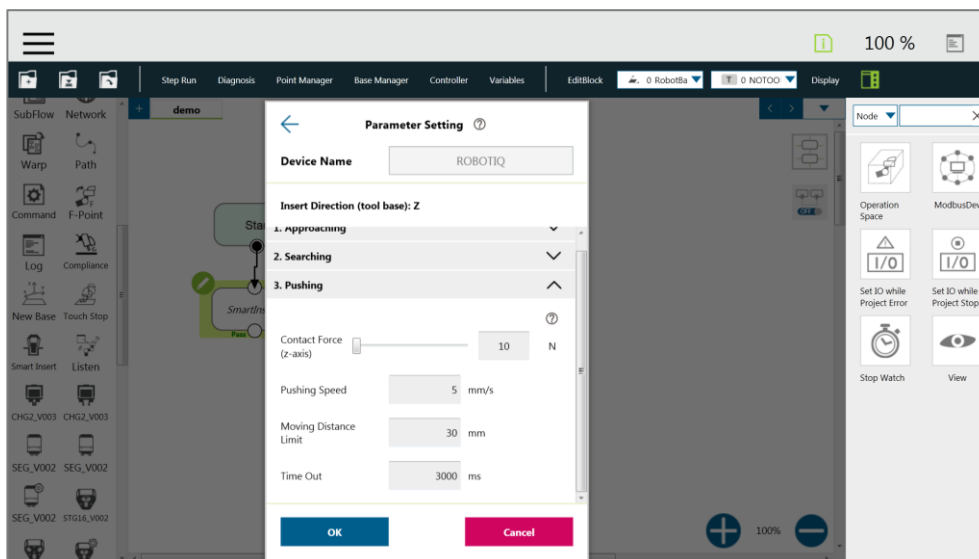

Pushing parameter setting interface

## 15. Operation Space

### 15.1 Overview

TMflow provides two spatial characteristics of plane and cube for operation space environment construction. When the robot crosses different operation space while running, the robot will switch between stop, Collaborative Mode and full speed mode. When calculating the position of robot and its related actions in Operation Spaces, the TCP is utilized as the reference point. In other words, the position of the TCP decides the actions in Operation Spaces of the robot. When working in the Collaborative Mode and full speed mode, all the safety setting, including TCP speed, TCP force, joint torque and etc. follows the settings in “Safety Setting”. However, pay attention that this function is not a safety function defined by TM Robot. This function is only suitable for dividing operation space, assisting the user in understanding the spatial concept during teaching and programming, or let the robot to decelerate in advance to allow smoother process of deceleration before the robot moves through a safety sensor installed in the space.

Regarding to the switching and triggering of Collaborative Mode, use the Safeguard Port : Collaborative Mode of this product. Add appropriate safety device when use such as appropriate installation and configuration of safety sensor connected to the safety protection port with dual channel connection.



**DANGER:**







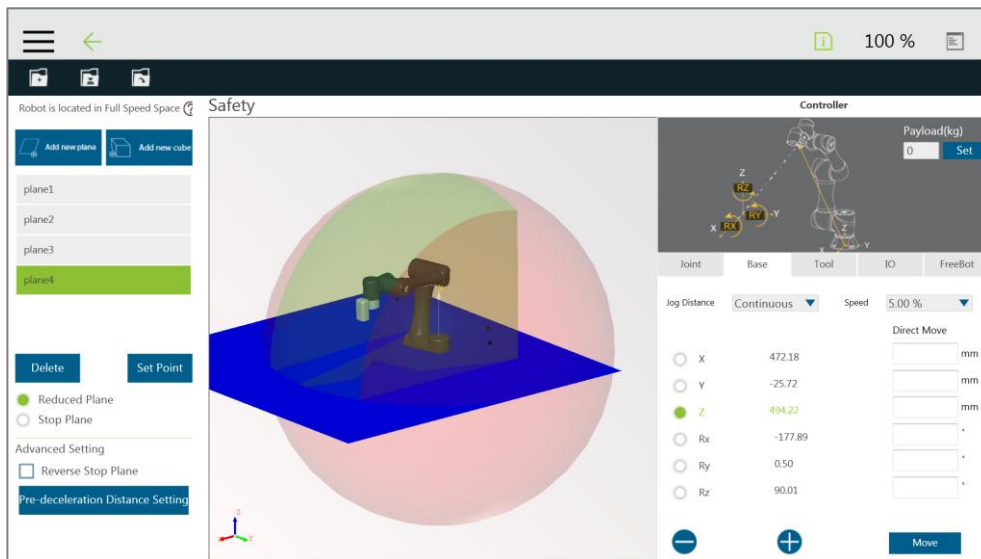

This function cannot be mistakenly used as a safety function. The user must conduct a comprehensive risk assessment according to the environment and conditions of use, and configure equipment such as a grating, laser scanner and others that comply with the safety regulations, and work with the safety protection port of this product from the external device to trigger the Collaborative Mode or pause. Set the operation environment correctly, or use other appropriate safety designs to prevent people from entering the robot's full speed space. This function is only to assist the user in understanding the space concept more easily during the teaching and programming process. The Reduced Plane / Space function shall only be used in the teaching process to know the Reduced Space and full-speed running area, instead of being mistakenly used in the switching between the Collaborative Mode and full speed mode, and mistakenly viewed as a safety function. When the Stop Plane/Space is used during the teaching process, the user shall regard this function as to avoid setting the point or motion across the prohibited area, and shall mistakenly regard this function as a purpose of space limitation related to safety that mistakenly regarded as a safety function. The Company clearly specifies the following potential residual risks: There is a risk that causes the robot to hit human body at full speed due to improper use of safe space settings or running incorrect projects.

## 15.2 Operation Space Setting Page

Click "Operation Space" in the Robot Setting Page to access the Operation Space Setting Page. As shown in the figure below, the left side of this page provides space setting, the middle is the virtual robot interface, and the right side is the controller interface.



The Operation Space Setting Function list on the Left Side is shown as follows.

	Add Plane		Delete the selected characteristics
	Add Cube		Reset Characteristics
	Pre-deceleration distance setting		Reverse Stop Plane
	Switch to Reduced Plane		
	Switch to Stop Plane		

The list will display all built characteristics. When the user clicks on the characteristics in the list, the robot virtual interface located in the center will display the selected characteristics in dark blue, and the user can delete, reset and other setting on the selected characteristics. When the robot is about to enter the deceleration zone, the robot will start deceleration in advance, but the state of the Indication Light Ring of the End Module will not change.

### 15.3 Add / Modify Plane Page

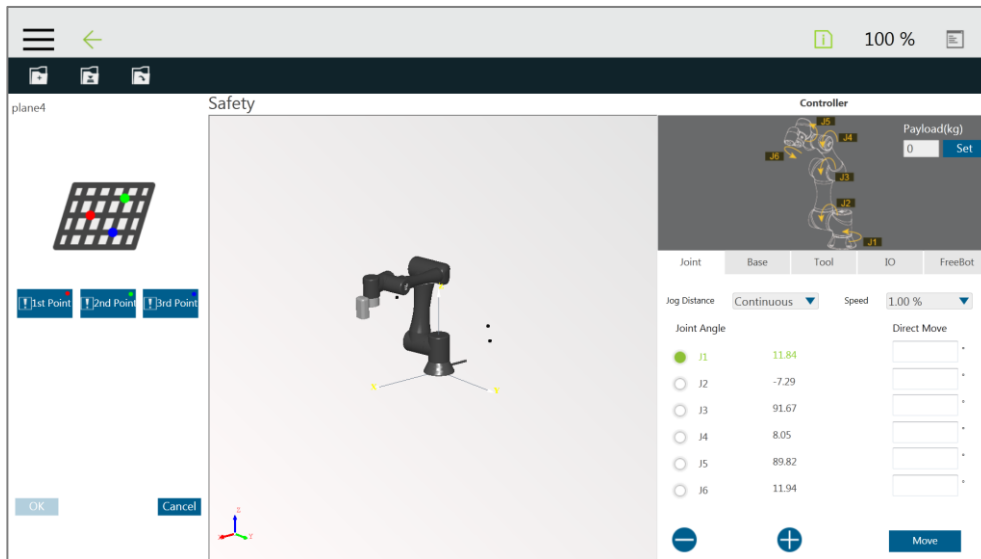

The Add / Modify Plane Page can be accessed by clicking the button for add new plane or click button of reset characteristics after selected the plane characteristics. In this page, the user can build a plane by setting three points. The set order of three points can be randomized. The robot virtual interface will be displayed with the corresponding color ball. When three points are set, a dark blue virtual plane will appear. At this time, click the OK button to build the plane. It is necessary to pay attention that when the phenomenon of common point or collinearity occurs, this virtual plane will not be able to be built. The button function list is shown as follows.



Set 1st Point



Set 2nd Point



Set 3rd Point

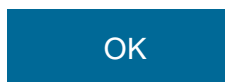

Confirm the built Plane



Cancel the built Plane

## Add / Modify Cube Page

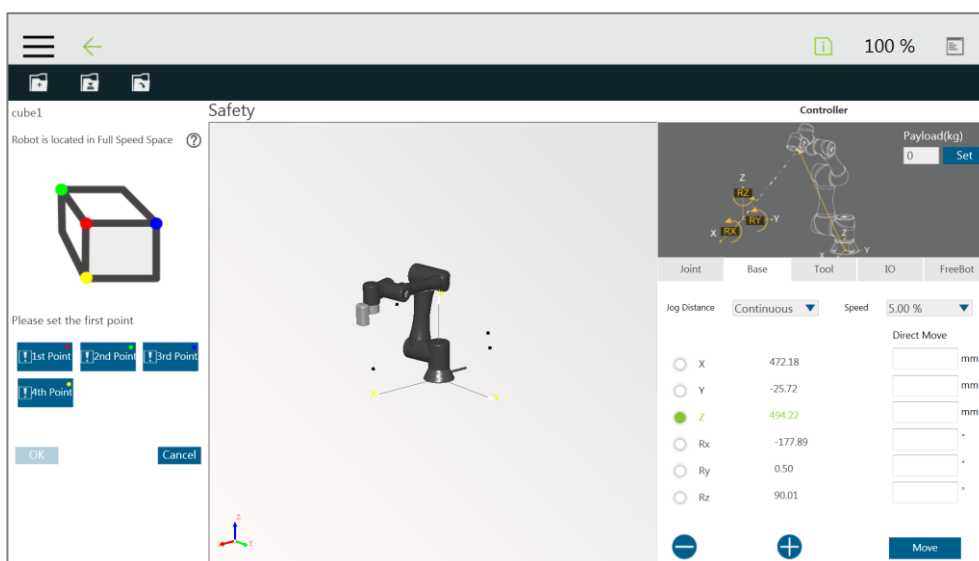

The Add/Modify Cube Page can be accessed by clicking the button for Add Cube or selecting the Cube characteristics, then click the Reset Characteristics button. In this page, the user can build a cube with the four point set by TCP. The set order of three points can be randomized. The robot virtual interface will be displayed with the corresponding color ball, but it needs to be built according to the relative relationship of the icons. After completed setting of the four points, a dark blue virtual cube will appear. Click the OK button at this time to build the Cube. It is necessary to pay attention that when the phenomenon of common point or collinearity occurs, this Cube will not be able to be built. The button function list is shown as follows.



Set 1st Point



Set 2nd Point



Set 3rd Point



Set 4th Point



Confirm the creation of Cube



Cancel the creation of Cube



After the user completed building the operation space, it can be identified from the 3D screen: as shown in the following figure, the whole sphere displayed is the maximum movable range of the robot, the Reduced Space is in green block, the Full Speed Space is in red block, and the Stop Space is the space removed from the robot's movable range.

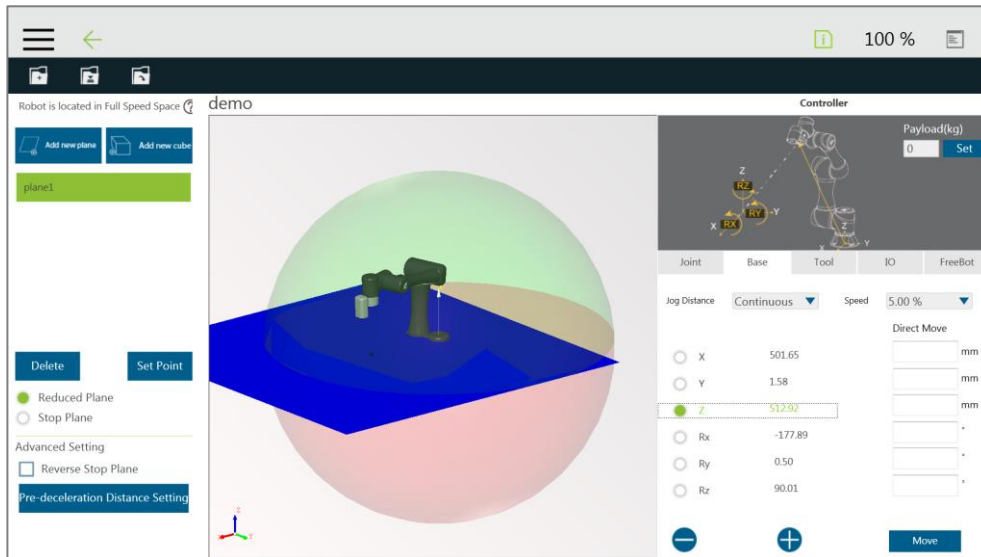

#### **DANGER:**

The convenient setting of the operation space is achieved by a complex spatial geometry algorithm, which may result in a space division that is not as expected by the user under certain specific setting conditions. The user shall fully check whether the result of the space sphere in the 3D image is as expected before saving the settings. Improper use of a safe space configuration, or saving unexpected settings, or an incorrectly run project, can all cause situations where the robot hits a human body at full speed.



## 15.4 Operation Space Setting Page in the Project Editing Page

After built the plane, the user can access the Project Editing Page. Click "Operation Space" on the folded panel on the right side to access the Operation Space Setting Page.

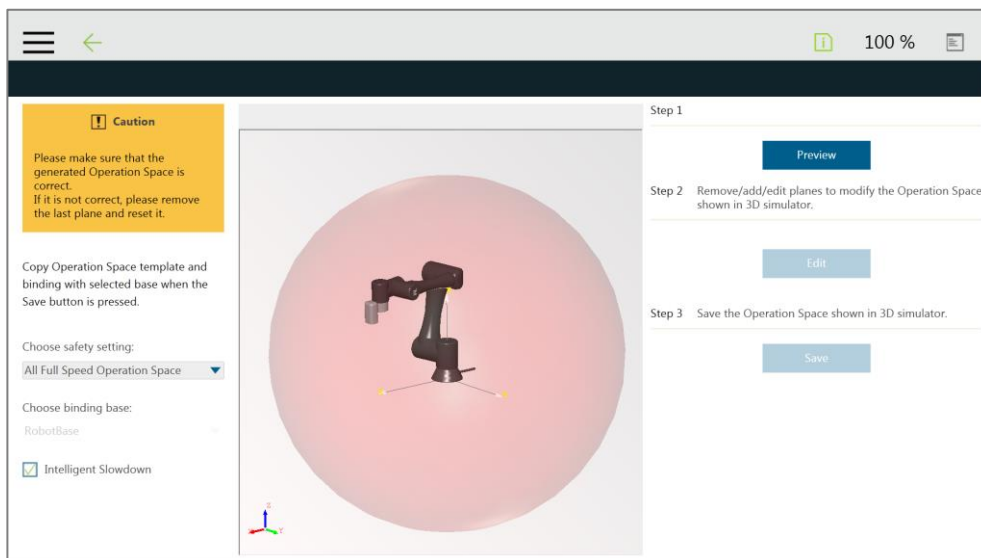
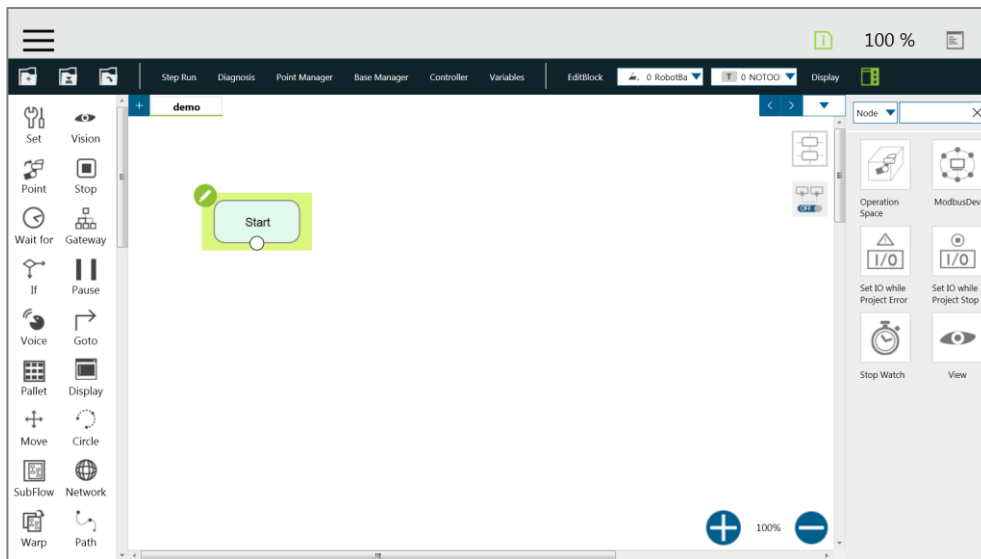

The Intelligent Slowdown function in the lower left of the figure above provides the ability for the robot to automatically pre-decelerate in the schedule of the project node. If this function is checked, when the project is running, the system will calculate whether the robot's next node position crosses the space, if the space is crossed, then the robot will start deceleration at the current node.



### **DANGER:**

The Intelligent Slowdown function only judges whether the initial position and end point of the robot TCP enters the deceleration zone from the full-speed zone or not. Therefore, if the initial position and the end point are both located in the full-speed zone, and the TCP position enters the deceleration zone during the operation, the smart pre-deceleration function will not activate.

On the Project Function Menu in Project Editing Page, open the "Operation Space" setting. After pressed "Preview", combine the selected operation space selected by "Select Operation Space Setting" and the Base set by the Choose binding Base, and display on the 3D simulator. If there is a need to modify this operation space, the button can be pressed to access modification. Before saving, the user is responsible for checking the correctness of the displayed operation space and maintaining its own safety. If the generated operation space is not correct, click the Edit button and remove the last plane, then perform reset again; after pressed Save, the system will save the operation space displayed by the 3D simulator. Binding Base is a function that facilitates the user to record the definition of the operation space in the environmental Base; however, pay attention that based on the safety consideration that Binding is a one-time action. After Binding, if the Base is updated in other interfaces, it needs to be returned to this page for binding again.

Preview	Display the generated operation space on the 3D simulator.
Edit	Delete, add, or edit planes to modify the operation space displayed in the 3D simulator.
Save	Save the display screen in the 3D Simulator.

After clicked the "Preview" button, if the set page needs to be modified, click the "Edit" button below Step2, to modify in this screen.

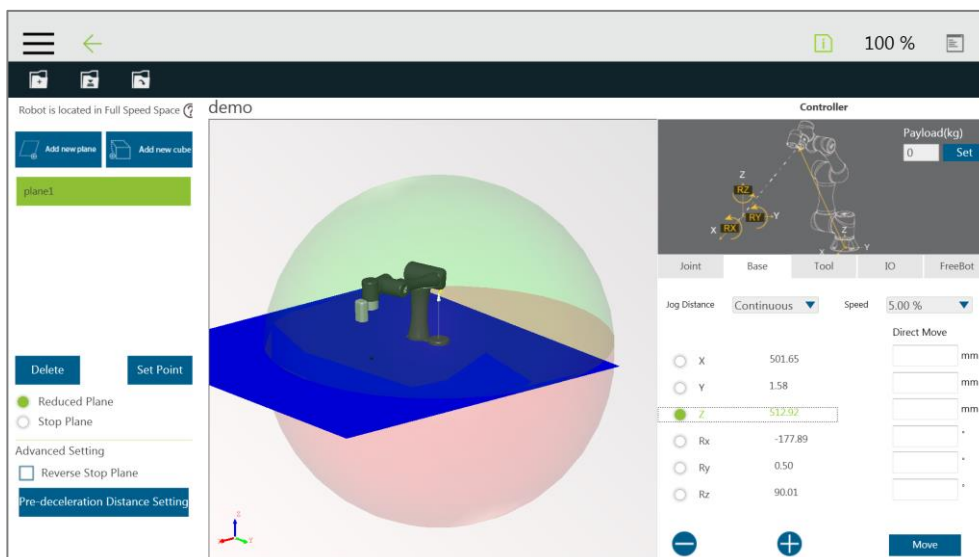

If the modification is completed, click the Save button on the top left to save the file. If modification is not required, then click the X button on the top right to return to the setting page without saving.

## 16. Appendix Modbus List

Classify	Function Code	R/W	Note
Digital Output	01	R	Classification description
Digital Input	02	R	
Register Output	03	R	
Register Input	04	R	
Digital Output	05	W	
Register Output	06	W	

Robot Status	FC	Address <sub>10</sub>	Address <sub>16</sub>	Type	R/W	Note
Error or Not	02	7201	1C21	Bool	R	Yes:1 No: 0
Project Running or Not	02	7202	1C22	Bool	R	Yes:1 No: 0
Project Editing or Not	02	7203	1C23	Bool	R	Yes:1 No: 0
Project Pause or Not	02	7204	1C24	Bool	R	Yes:1 No: 0
Get Control or Not	02	7205	1C25	Bool	R	Yes:1 No: 0

End Module	FC	Address <sub>10</sub>	Address <sub>16</sub>	Type	R/W	Note
DI 0	02	0800	0320	Bool	R	High: 1 Low: 0
DI 1	02	0801	0321	Bool	R	
DI 2	02	0802	0322	Bool	R	
DO 0	01/05	0800	0320	Bool	R/W	
DO 1	01/05	0801	0321	Bool	R/W	
DO 2	01/05	0802	0322	Bool	R/W	
DO 3	01/05	0803	0323	Bool	R/W	
AI 0	04	0800~0801	0320~0321	Float	R	

Control Box DI/O	FC	Address <sub>10</sub>	Address <sub>16</sub>	Type	R/W	Note
DO 0	01/05	0000	0000	Bool	R/W	High: 1 Low: 0
DO 1	01/05	0001	0001	Bool	R/W	
DO 2	01/05	0002	0002	Bool	R/W	
DO 3	01/05	0003	0003	Bool	R/W	
DO 4	01/05	0004	0004	Bool	R/W	
DO 5	01/05	0005	0005	Bool	R/W	
DO 6	01/05	0006	0006	Bool	R/W	
DO 7	01/05	0007	0007	Bool	R/W	
DO 8	01/05	0008	0008	Bool	R/W	
DO 9	01/05	0009	0009	Bool	R/W	
DO 10	01/05	0010	000A	Bool	R/W	
DO 11	01/05	0011	000B	Bool	R/W	
DO 12	01/05	0012	000C	Bool	R/W	
DO 13	01/05	0013	000D	Bool	R/W	
DO 14	01/05	0014	000E	Bool	R/W	
DO 15	01/05	0015	000F	Bool	R/W	
DI 0	02	0000	0000	Bool	R	
DI 1	02	0001	0001	Bool	R	
DI 2	02	0002	0002	Bool	R	
DI 3	02	0003	0003	Bool	R	
DI 4	02	0004	0004	Bool	R	
DI 5	02	0005	0005	Bool	R	
DI 6	02	0006	0006	Bool	R	
DI 7	02	0007	0007	Bool	R	
DI 8	02	0008	0008	Bool	R	
DI 9	02	0009	0009	Bool	R	
DI 10	02	0010	000A	Bool	R	
DI 11	02	0011	000B	Bool	R	
DI 12	02	0012	000C	Bool	R	
DI 13	02	0013	000D	Bool	R	
DI 14	02	0014	000E	Bool	R	
DI 15	02	0015	000F	Bool	R	

Control Box AI/O	FC	Address <sub>10</sub>	Address <sub>16</sub>	Type	R/W	Note
AO 0	03/06	0000~0001	0000~0001	Float	R/W	
AI 0	04	0000~0001	0000~0001	Float	R	
AI 1	04	0002~0003	0002~0003	Float	R	

Robot Coordinate	FC	Address <sub>10</sub>	Address <sub>16</sub>	Type	R/W	Note1	Note2
X (Cartesian coordinates)	04	7001~7002	1B59~1B5A	Float	R	Dword	mm
Y (Cartesian coordinates)	04	7003~7004	1B5B~1B5C	Float	R	Dword	mm
Z (Cartesian coordinates)	04	7005~7006	1B5D~1B5E	Float	R	Dword	mm
Rx (Cartesian coordinates)	04	7007~7008	1B5F~1B60	Float	R	Dword	degree
Ry (Cartesian coordinates)	04	7009~7010	1B61~1B62	Float	R	Dword	degree
Rz (Cartesian coordinates)	04	7011~7012	1B63~1B64	Float	R	Dword	degree
Joint 1	04	7013~7014	1B65~1B66	Float	R	Dword	degree
Joint 2	04	7015~7016	1B67~1B68	Float	R	Dword	degree
Joint 3	04	7017~7018	1B69~1B6A	Float	R	Dword	degree
Joint 4	04	7019~7020	1B6B~1B6C	Float	R	Dword	degree
Joint 5	04	7021~7022	1B6D~1B6E	Float	R	Dword	degree
Joint 6	04	7023~7024	1B6F~1B70	Float	R	Dword	degree
X (Tool coordinate)	04	7025~7026	1B71~1B72	Float	R	Dword	mm
Y (Tool coordinates)	04	7027~7028	1B73~1B74	Float	R	Dword	mm
Z (Tool coordinates)	04	7029~7030	1B75~1B76	Float	R	Dword	mm
Rx (Tool coordinates)	04	7031~7032	1B77~1B78	Float	R	Dword	degree
Ry (Tool coordinates)	04	7033~7034	1B79~1B7A	Float	R	Dword	degree
Rz (Tool coordinates)	04	7035~7036	1B7B~1B7C	Float	R	Dword	degree
X (Robot coordinates)	04	7037~7038	1B7D~1B7E	Float	R	Dword	mm
Y (Robot coordinates)	04	7039~7040	1B7F~1B80	Float	R	Dword	mm
Z (Robot coordinates)	04	7041~7042	1B81~1B82	Float	R	Dword	mm
Rx (Robot coordinates)	04	7043~7044	1B83~1B84	Float	R	Dword	degree
Ry (Robot coordinates)	04	7045~7046	1B85~1B86	Float	R	Dword	degree
Rz (Robot coordinates)	04	7047~7048	1B87~1B88	Float	R	Dword	degree

Robot Coordinate (When touchstop node be triggered)	FC	Address <sub>10</sub>	Address <sub>16</sub>	Type	R/W	Note1	Note2
X (Cartesian coordinates)	04	7401~7402	1CE9~1CEA	Float	R	Dword	mm
Y (Cartesian coordinates)	04	7403~7404	1CEB~1CEC	Float	R	Dword	mm
Z (Cartesian coordinates)	04	7405~7406	1CED~1CEE	Float	R	Dword	mm
Rx (Cartesian coordinates)	04	7407~7408	1CEF~1CF0	Float	R	Dword	degree
Ry (Cartesian coordinates)	04	7409~7410	1CF1~1CF2	Float	R	Dword	degree
Rz (Cartesian coordinates)	04	7411~7412	1CF3~1CF4	Float	R	Dword	degree
Joint 1	04	7413~7414	1CF5~1CF6	Float	R	Dword	degree
Joint 2	04	7415~7416	1CF7~1CF8	Float	R	Dword	degree
Joint 3	04	7417~7418	1CF9~1CFA	Float	R	Dword	degree
Joint 4	04	7419~7420	1CFB~1CFC	Float	R	Dword	degree
Joint 5	04	7421~7422	1CFD~1CFE	Float	R	Dword	degree
Joint 6	04	7423~7424	1CFF~1D00	Float	R	Dword	degree
X (Tool coordinate)	04	7425~7426	1D01~1D02	Float	R	Dword	mm
Y (Tool coordinates)	04	7427~7428	1D03~1D04	Float	R	Dword	mm
Z (Tool coordinates)	04	7429~7430	1D05~1D06	Float	R	Dword	mm
Rx (Tool coordinates)	04	7431~7432	1D07~1D08	Float	R	Dword	degree
Ry (Tool coordinates)	04	7433~7434	1D09~1D0A	Float	R	Dword	degree
Rz (Tool coordinates)	04	7435~7436	1D0B~1D0C	Float	R	Dword	degree
X (Robot coordinates)	04	7437~7438	1D0D~1D0E	Float	R	Dword	mm
Y (Robot coordinates)	04	7439~7440	1D0F~1D10	Float	R	Dword	mm
Z (Robot coordinates)	04	7441~7442	1D11~1D12	Float	R	Dword	mm
Rx (Robot coordinates)	04	7443~7444	1D13~1D14	Float	R	Dword	degree
Ry (Robot coordinates)	04	7445~7446	1D15~1D16	Float	R	Dword	degree
Rz (Robot coordinates)	04	7447~7448	1D17~1D18	Float	R	Dword	degree

Robot Stick	FC	Address <sub>10</sub>	Address <sub>16</sub>	Type	R/W	Note
Project Running Speed	04	7101	1BBD	Int16	R	%
M/A Mode	04	7102	1BBE	Int16	R	A:1; M:2
Play/Pause	05	7104	1BC0	Bool	W	Bottom down: 1 Bottom up: 0
Stop	05	7105	1BC1	Bool	W	
Stick+	05	7106	1BC2	Bool	W	
Stick-	05	7107	1BC3	Bool	W	

Others 1	FC	Address <sub>10</sub>	Address <sub>16</sub>	Type	R/W	Note
Current Time: Year	04	7301	1C85	Int16	R	
Current Time: Month	04	7302	1C86	Int16	R	
Current Time: Date	04	7303	1C87	Int16	R	
Current Time: Hour	04	7304	1C88	Int16	R	
Current Time: Minute	04	7305	1C89	Int16	R	
Current Time: Second	04	7306	1C8A	Int16	R	
IPC Connect Number	04	7307	1C8B	Int16	R	≤ User Connect Limit
HMI Version	04	7308~7312	1C8C~1C90	String	R	
User Connect Limit	04	7330	1CA2	Int16	R	0: No limit
Modbus Proxy Port	04	7319	1C97	Int16	R	5432
Last Error Code	04	7320~7321	1C98~1C99	Int32	R	Dword
Last Error Time: Year	04	7322	1C9A	Int16	R	
Last Error Time: Month	04	7323	1C9B	Int16	R	
Last Error Time: Date	04	7324	1C9C	Int16	R	
Last Error Time: Hour	04	7325	1C9D	Int16	R	
Last Error Time: Minute	04	7326	1C9E	Int16	R	
Last Error Time: Second	04	7327	1C9F	Int16	R	



Others 2	FC	Address <sub>10</sub>	Address <sub>16</sub>	Type	R/W	Note1	Note2
Controller Temperature	04	7340~7341	1CAC~1CAD	Float	R	Dword	Celsius
Manipulator Voltage	04	7342~7343	1CAE~1CAF	Float	R	Dword	Voltage
Manipulator Power Consumption	04	7344~7345	1CB0~1CB1	Float	R	Dword	Watt
Manipulator Current	04	7346~7347	1CB2~1CB3	Float	R	Dword	A
Control Box IO Current	04	7348~7349	1CB4~1CB5	Float	R	Dword	mA
End Module IO Current	04	7350~7351	1CB6~1CB7	Float	R	Dword	mA
X (TCP Value)	04	7354~7355	1CBA~1CBB	Float	R	Dword	mm
Y (TCP Value)	04	7356~7357	1CBC~1CBD	Float	R	Dword	mm
Z (TCP Value)	04	7358~7359	1CBE~1CBF	Float	R	Dword	mm
RX (TCP Value)	04	7360~7361	1CC0~1CC1	Float	R	Dword	degree
RY (TCP Value)	04	7362~7363	1CC2~1CC3	Float	R	Dword	degree
RZ (TCP Value)	04	7364~7365	1CC4~1CC5	Float	R	Dword	degree
Mass (TCP Value)	04	7366~7367	1CC6~1CC7	Float	R	Dword	Kg
Ixx (Principal moments of inertia)	04	7368~7369	1CC8~1CC9	Float	R	Dword	
Iyy (Principal moments of inertia)	04	7370~7371	1CCA~1CCB	Float	R	Dword	
Izz (Principal moments of inertia)	04	7372~7373	1CCC~1CCD	Float	R	Dword	
X (Mass center frames with principal axes w.r.t. tool frame)	04	7374~7375	1CCE~1CCF	Float	R	Dword	mm
Y (Mass center frames with principal axes w.r.t. tool frame)	04	7376~7377	1CD0~1CD1	Float	R	Dword	mm
Z (Mass center frames with principal axes w.r.t. tool frame)	04	7378~7379	1CD2~1CD3	Float	R	Dword	mm
RX (Mass center frames with principal axes w.r.t. tool frame)	04	7380~7381	1CD4~1CD5	Float	R	Dword	degree
RY (Mass center frames with principal axes w.r.t. tool frame)	04	7382~7383	1CD6~1CD7	Float	R	Dword	degree

tool frame)							
RZ (Mass center frames with principal axes w.r.t. tool frame)	04	7384~7385	1CD8~1CD9	Float	R	Dword	degree
Sreserve 1	04	7501~7502	1D4D~1D4E	Float	R	Dword	
Sreserve 2	04	7503~7504	1D4F~1D50	Float	R	Dword	
Sreserve 3	04	7505~7506	1D51~1D52	Float	R	Dword	
Sreserve 4	04	7507~7508	1D53~1D54	Float	R	Dword	
Sreserve 5	04	7509~7510	1D55~1D56	Float	R	Dword	
Sreserve 6	04	7511~7512	1D57~1D58	Float	R	Dword	
Sreserve 7	04	7513~7514	1D59~1D5A	Float	R	Dword	
Sreserve 8	04	7515~7516	1D5B~1D5C	Float	R	Dword	
Sreserve 9	04	7517~7518	1D5D~1D5E	Float	R	Dword	
Sreserve 10	04	7519~7520	1D5F~1D60	Float	R	Dword	
Sreserve 11	04	7521~7522	1D61~1D62	Float	R	Dword	
Sreserve 12	04	7523~7524	1D63~1D64	Float	R	Dword	
Sreserve 13	04	7525~7526	1D65~1D66	Float	R	Dword	
Sreserve 14	04	7527~7528	1D67~1D68	Float	R	Dword	
Sreserve 15	04	7529~7530	1D69~1D6A	Float	R	Dword	
Sreserve 16	04	7531~7532	1D6B~1D6C	Float	R	Dword	
Sreserve 17	04	7533~7534	1D6D~1D6E	Float	R	Dword	
Sreserve 18	04	7535~7536	1D6F~1D70	Float	R	Dword	
Sreserve 19	04	7537~7538	1D71~1D72	Float	R	Dword	
Sreserve 20	04	7539~7540	1D73~1D74	Float	R	Dword	
Sreserve 21	04	7541~7542	1D75~1D76	Float	R	Dword	
Sreserve 22	04	7543~7544	1D77~1D78	Float	R	Dword	
Sreserve 23	04	7545~7546	1D79~1D7A	Float	R	Dword	
Sreserve 24	04	7547~7548	1D7B~1D7C	Float	R	Dword	
Sreserve 25	04	7549~7550	1D7D~1D7E	Float	R	Dword	
Sreserve 26	04	7551~7552	1D7F~1D80	Float	R	Dword	
Sreserve 27	04	7553~7554	1D81~1D82	Float	R	Dword	
Sreserve 28	04	7555~7556	1D83~1D84	Float	R	Dword	
Sreserve 29	04	7557~7558	1D85~1D86	Float	R	Dword	
Sreserve 30	04	7559~7560	1D87~1D88	Float	R	Dword	

Others 3	FC	Address <sub>10</sub>	Address <sub>16</sub>	Type	R/W	Note
Robot Light	04	7332	1CA4	Int16	R	1: Solid Red, fatal error. 3: Solid Blue, standby in Auto Mode. 4: Flashing Blue, project running in Auto Mode. 5: Solid Green, standby in Manual Mode. 6: Flashing Green, project running in Manual Mode. 9: Alternating Blue&Red, Auto Mode error. 10: Alternating Green&Red, Manual Mode error.

Others 4	FC	Address <sub>10</sub>	Address <sub>16</sub>	Type	R/W	Note
User Define Area	01/02/03/04/05/06	9000~9999	2328~270F	User-define	R/W	

**OMRON Corporation Industrial Automation Company**

Kyoto, JAPAN

Contact: [www.ia.omron.com](http://www.ia.omron.com)

**Regional Headquarters**

OMRON EUROPE B.V.  
Wegalaan 67-69, 2132 JD Hoofddorp  
The Netherlands  
Tel: (31)2356-81-300/Fax: (31)2356-81-388

OMRON ASIA PACIFIC PTE. LTD.  
No. 438A Alexandra Road # 05-05/08 (Lobby 2),  
Alexandra Technopark,  
Singapore 119967  
Tel: (65) 6835-3011/Fax: (65) 6835-2711

OMRON ELECTRONICS LLC  
2895 Greenspoint Parkway, Suite 200 Hoffman Estates,  
IL 60169 U.S.A.  
Tel: (1) 847-843-7900/Fax: (1) 847-843-7787

OMRON ADEPT TECHNOLOGIES, INC.  
4550 Norris Canyon Road, Suite 150, San Ramon, CA 94583 U.S.A.  
Tel: (1) 925-245-3400/Fax: (1) 925-960-0590

OMRON (CHINA) CO., LTD.  
Room 2211, Bank of China Tower, 200 Yin Cheng Zhong Road,  
PuDong New Area, Shanghai, 200120, China  
Tel: (86) 21-5037-2222/Fax: (86) 21-5037-2200

Authorized Distributor:

© OMRON Corporation 2018 All Rights Reserved.  
In the interest of product improvement,  
specifications are subject to change without notice.

Cat. No. I626-E-01

1018 (1018)

19888-400 A