

INSTALLATION, OPERATION AND SERVICE MANUAL

DOUBLE PANTOGRAPH LIFT

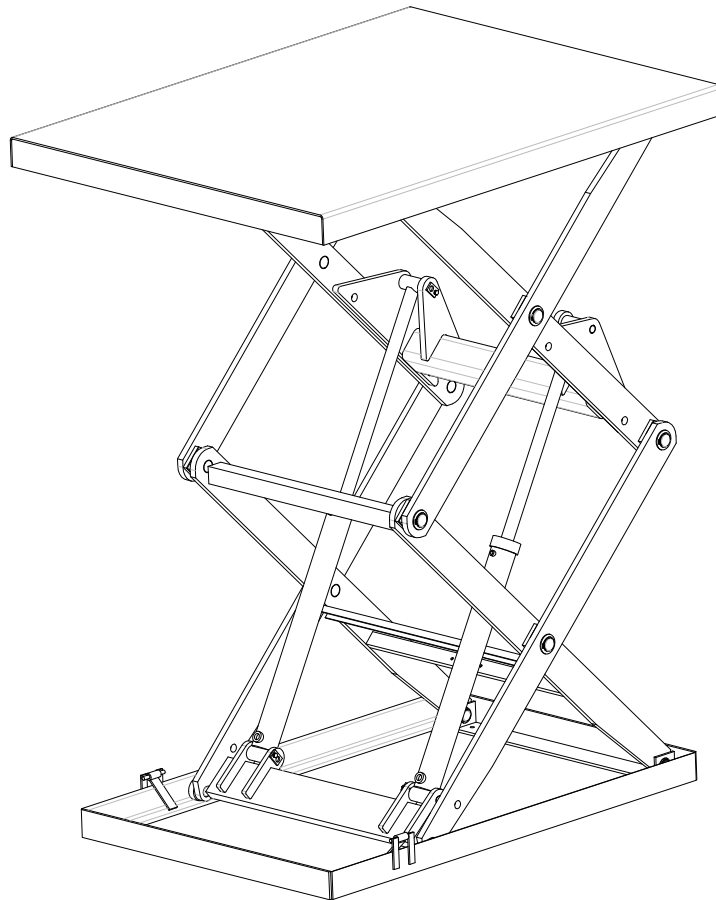

Autoquip[®]

P.O. Box 1058 • 1058 West Industrial Avenue • Guthrie, OK 73044-1058 • 888-811-9876 •
• 405-282-5200 • FAX: 405-282-3302 • www.autoquip.com

Item #830DPL

Version 2.0
Dec. 2011

TABLE OF CONTENTS

Identification and Inspection	3
Responsibility of Owners/Users	4
Safety Signal Words	5
Safety Practices	6
Label Identification	11
Specifications	15
Lift Blocking Instructions	17
Installation Instructions	22
Operating Instructions	34
Routine Maintenance	35
General Maintenance	39
Replacement Parts List	56
Troubleshooting Analysis	67
Warranty	73

IMPORTANT

Please read and understand this manual prior to installation or operation of this lift. Failure to do so could lead to property damage and/or serious personal injury. If questions arise, call a local representative or *Autoquip Corporation* at 1-888-811-9876 or 405-282-5200.

IDENTIFICATION & INSPECTION

IDENTIFICATION

When ordering parts or requesting information or service on this lift, PLEASE REFER TO THE MODEL AND SERIAL NUMBER. This information is on a nameplate attached to the leg assembly. Replacement parts are available from a local *Autoquip* distributor.

LIFT DOCUMENTATION

LIFT MODEL No: _____ LIFT SERIAL No: _____
Date Purchased: ____ / ____ / ____

INSPECTION

Immediately upon receipt of the lift, a visual inspection should be made to determine that the lift has not been damaged in transit. Any damage found must be noted on the delivery receipt. In addition to this preliminary inspection, the lift should be carefully inspected for concealed damage. Any concealed damage found that was not noted on the delivery receipt should be reported in writing to the delivering carrier within 48 hours.

The following is a checklist that will aid in the inspection of the lift.

1. Examine entire unit for any signs of mishandling. Pay special attention to the power unit and controls.
 2. Thoroughly examine all connections, making sure they have not vibrated loose during transit.
 3. After installation, raise the lift and inspect the base frame, platform, scissors assembly, and cylinder plumbing connections.
-

PLANNED MAINTENANCE PROGRAM

A local *Autoquip* representative provides a Planned Maintenance Program (PMP) for this equipment using factory-trained personnel. Call a local representative or *Autoquip Corporation* at 1-888-811-9876 or 405-282-5200 for more information.

RESPONSIBILITY OF OWNERS/USERS

DEFLECTION

It is the responsibility of the user/purchaser to advise the manufacturer where deflection may be critical to the application.

INSPECTION & MAINTENANCE

The lift shall be inspected & maintained in proper working order in accordance with this manual and with other applicable safe operating practices.

REMOVAL FROM SERVICE

Any lift not in safe operating condition such as, but not limited to, excessive leakage, missing rollers, pins, or fasteners, any bent or cracked structural members, cut or frayed electric, hydraulic, or pneumatic lines, damaged or malfunctioning controls or safety devices, etc. shall be removed from service until it is repaired to the original manufacturer's standards.

REPAIRS

All repairs shall be made by qualified personnel in conformance with Autoquip's instructions.

OPERATORS

Only trained personnel and authorized personnel shall be permitted to operate the lift.

BEFORE OPERATION

Before using the lift, the operator shall have:

- Read or have explained, and understood, the manufacturer's operating instructions and safety rules.
- Inspected the lift for proper operation and condition. Any suspect item shall be carefully examined and a determination made by a qualified person as to whether it constitutes a hazard. All items not in conformance with Autoquip's specification shall be corrected before further use of the lift.

DURING OPERATION

The lift shall only be used in accordance with Autoquip's 'DP' O&M manual.

- Do not overload the lift.
- Ensure that all safety devices are operational and in place.
- Autoquip warrants this lift for 60,000 cycles each warranty year. This number of cycles is meant to represent normal, single shift duty. Exceeding this number of cycles shortens the life of the lift and the length of your warranty. It also indicates that a more robust lift design for high cycle lift should have been requested.

MODIFICATIONS OR ALTERATIONS

Modifications or alterations to industrial lifting equipment shall be made only with written permission of Autoquip. Autoquip does not foresee and does not anticipate unauthorized modifications, and these changes or alterations are grounds for voiding all warranties.

SAFETY SIGNAL WORDS

SAFETY ALERTS (Required Reading!)

The following SAFETY ALERTS are intended to create awareness of owners, operators, and maintenance personnel of the potential safety hazards and the steps that must be taken to avoid accidents. These same alerts are inserted throughout this manual to identify specific hazards that may endanger uninformed personnel. Identification of every conceivable hazardous situation is impossible. Therefore, all personnel have the responsibility to diligently exercise safe practices whenever exposed to this equipment.



DANGER !

Identifies a hazardous situation which, if not avoided, will result in death or severe personal injury.



WARNING !

Identifies a hazardous situation which, if not avoided, could result in death or serious personal injury.



CAUTION !

Identifies a hazardous situation which, if not avoided, may result in minor or moderate personal injury.

NOTICE !

Indicates a potentially hazardous situation which, if not avoided, may result in property or equipment damage.

SAFETY PRACTICES

Read and understand this manual and all labels prior to operating or servicing the lift. All labels are provided in accordance with ANSI Z535.4.



DANGER !

Do not work under the lift without a Maintenance Device! To avoid personal injury, NEVER go under the lift platform until the load is removed and the scissors mechanism is securely blocked in the open position. See "Lift Blocking Instructions" section.



DANGER !

Do not install the lift in a pit unless it has a bevel toe guard or other approved toe protection. A shear point can exist which can cause severe injury to the foot.



DANGER !

HIGH VOLTAGE!! Disconnect and/or lock out the electrical supply to the power unit prior to any maintenance being performed.



DANGER !

Scissors lifts are designed individually for a specific load and application. To avoid personal injury, do not change the load or application from the original design.



DANGER !

Failure to relieve lift system pressure could result in the sudden and unexpected release of pressure during maintenance and/or repair of the lift and result in severe injury to the personnel and/or damage to the lift.

SAFETY PRACTICES



WARNING !

Do not make modifications to the lift such as extending the platform length or width, this could cause the platform to tip. Do not add unauthorized or unspecified components to the lift. Modifications to the lift can result in unsafe operating conditions which could lead to serious injury or death.



WARNING !

If the lift is equipped with handrails, do not operate this equipment without handrails and snap chains in place.



WARNING !

Under no circumstances should the down flow control valve be removed, from the Contractor Power Unit or the Deltatrol on the Vertical Power Unit, to obtain faster lowering speed. A loaded lift can reach dangerous and destructive speed.



WARNING !

Do not attempt to remove the velocity fuse until the maintenance block securely supports the lift and all hydraulic pressure has been removed from the lifting cylinders and hydraulic hoses. Failure to do so could result in personal injury or death.



WARNING !

To avoid personal injury, stand clear of scissors leg mechanism while lift is in motion.

SAFETY PRACTICES



WARNING !

All warning and information decals should be in place as outlined in the “Label Identification” section. If decals are missing or damaged, they should be replaced with new ones. Contact *Autoquip* for replacements.

WARNING



Lift platforms traveling below floor levels may create openings, and the shape of the load and how the load is arranged on the lift may create a toe hazard as the load passes the top edge of the pit. Both situations may require guarding in accordance with Federal Regulations. Any such guarding must be installed prior to operating the lift



WARNING !

The hydraulic velocity fuse (HVF) must be properly installed! The HVF is attached to the elbow fitting in the trust angle port (casing end) of the cylinder. Do not use a swivel fitting between the HVF and cylinder. If the HVF is installed improperly, it will not lock up in the event of a catastrophic hydraulic line break.



WARNING !

Use properly rated hoses only! Never use fittings or hoses that are not properly rated for the intended use. Contact *Autoquip* for replacements.



WARNING !

Never exceed the rated capacity of the lift! Overloading, or uneven loading, could result in load instability and cause serious personal injury.

SAFETY PRACTICES



WARNING !

Any lift which has a hinged throw-over bridge damaged to the point of hanging more than 30 degrees below horizontal is in violation of the safety standards set forth in ANSI MH29.1 and **MUST** be taken out of service until the bridge is repaired or replaced. Failure to do so could result in severe personal injury.



WARNING !

Lifts should not be overloaded beyond the established capacity as damage and/or personal injury may result.



WARNING !

Only trained and qualified personnel should operate this equipment.



WARNING !

Whenever raising or lowering the lift, personnel should maintain a safe operating distance of at least 36" to avoid personal injury.



WARNING !

Any time the velocity fuses (HVF) have been tripped, the owner must investigate the cause of the trip and ensure any necessary corrective actions been taken, prior to resumption of normal lift operation. Failure to do so could result in personal injury.



CAUTION !

Spilled oil is very slippery, and may also present a fire hazard. Clean up all spilled oil to prevent personal injury or equipment damage.

SAFETY PRACTICES

NOTICE!

Do not continue to depress the “UP” button on the controller if the lift is not raising or if the lift has reached the fully raised position. To do so may result in permanent damage to the motor or pump.

NOTICE!

Never run the pump for more than a couple of seconds without pumping oil. This applies to low oil conditions, improper motor rotation, running the pump against the relief pressure after the lift is fully raised against the physical stops, running overloaded beyond capacity, or running at reduced speed because of pinched or obstructed hydraulic lines.

NOTICE!

Do not operate the power unit on relief for more than a few seconds. When on relief, the valve will make a squealing sound.

NOTICE!

Precautions should be taken to prevent the introduction of contaminants such as dirt or other foreign material into the system through open fittings, pipes or disassembled components. Contamination will ruin the hydraulic system.

NOTICE!

Use only approved oils in the lift. See “Specifications” section.

LABEL IDENTIFICATION

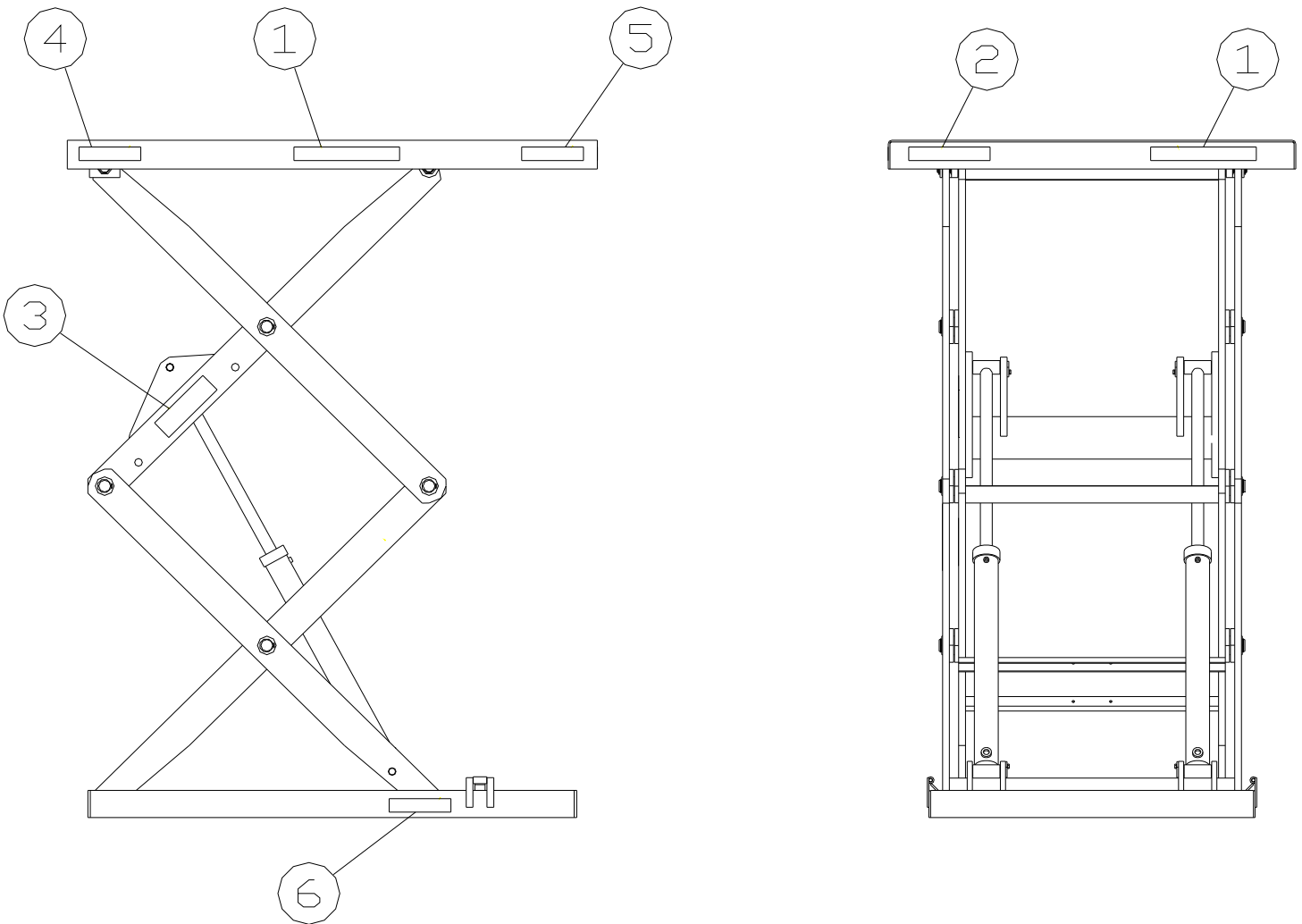

Figure 1: Label Placement

Double Pantograph Labels			
Label No.	Qty	Description	Part No.
1	4	Danger – Do Not Put Hands or Feet . . .	36430050
2	2	Caution – Familiarize Yourself with Operators Manual	36401487
3	1	<i>Autoquip</i> Serial Number Nameplate	36401560
4	2	Capacity	36401586
5	2	<i>Autoquip</i> Logo	36403220
6	2	Maintenance Device	36400257
7	4	Warning: Do Not Operate This Equipment Without . . .	36403715
8	4	Danger – Do Not Put Hands Or Feet (Modified). . .	36403715M
		NOTE: Label No. 7 & 8 are used on units with riders	

LABEL IDENTIFICATION

Note: Labels shown here are not to actual size, see Figure 1 for location of label on lift.



Label 1: General Purpose Decal (36430050)
(Do Not Put Hands or Feet ...)



Label 2: Familiarize Yourself Decal (36401487)

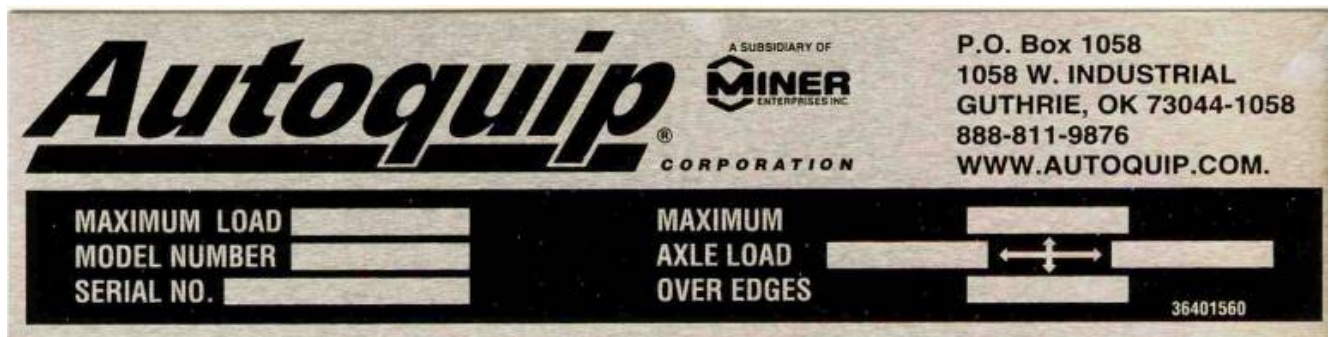

Label 3: Serial Number Nameplate (36401560)

LABEL IDENTIFICATION

Note: Labels shown here are not to actual size,
see Figure 1 for location of label on lift.



Label 4: CAPACITY Decal (36401586)



36403220

Label 5: AUTOQUIP LOGO Decal (36403220)



Label 6: Maintenance Device Label (36400257)

LABEL IDENTIFICATION

Note: Labels shown here are not to actual size, see Figure 1 for location of label on lift.



Label 7: Handrail Label (36403715)

Add label to top rail of the Handrail if equipped with Handrails



Label 8: Modified General Purpose Decal (36430050M)

Replaces label 1 if lift is equipped with Handrails

SPECIFICATIONS

Travel	Cap. (lbs.)	Model	Ld Ht (in.)	Max End Load	Max Side Load	Std Min Platform	Max Platform	HP	Speed fpm/sec	Ship Wt. (min. Platf)
36*	500	36DP05***	8.5	500	200	24 x 32	36 x 48	3/4	27 / 7	350
	1500	36DP15	9.25	1000	500			1 1/2	25 / 8	400
	3000	36DP30	10.75	1500	1000			12 / 16	500	
48*	3000	48DP30	11.25	2000	1000	30 x 43	42 x 72	1 1/2	7 / 33	800
	6000	48DP60	12.75	2500	1200			5C	11.5 / 22	850
	9000	48DP90	15	3000	1500			9 / 38	1200	
	12000	48DP120	16.5	4000	1500			5.5 / 44	1450	
60	9000	60DP90	16.5	3000	1500	36 x 54	48 x 84	5C	8 / 37	1600
	12000*	60DP120	18	4000	1500			5V*	8.5 / 36	1700
72	9000	72DP90	17	3000	1500	36 x 62	48 x 84	5C	8 / 47	1800
	12000*	72DP120	18.5	4000	1500			5V*	8 / 46	2300
84	9000	84DP90	18	3000	1500	48 x 70	60 x 96	5C	7.5 / 56	2400
	12000*	84DP120	19.5	4000	1500			5V*	8 / 55	3000
96	9000	96DP90	19.5	3000	1500	48 x 80	60 x 104	5C	7 / 70	2950
	12000*	96DP120	20.5	4000	1500			5V*	7 / 68	3500
108	3000	108DP30	17.25	2000	1000	54 x 82	78 x 106	5C	8 / 67	2650
	6000	108DP60	17.25	2500	1200			8 / 67	2650	
	9000*	108DP90	20.5	3000	1500	54 x 88	78 x 112	5V*	11.75 / 46	3300
	12000*	108DP120	22	4000	1500			7.5 / 72	3900	
120	3000	120DP30	18.75	2000	1000	60 x 92	84 x 116	5C	6.8 / 88	3400
	6000	120DP60	18.75	2500	1200			6.8 / 88	3400	
	9000*	120DP90	21	3000	1500	60 x 96	84 x 120	5V*	8 / 73	4400
	12000*	120DP120	23	4000	1500			5000		
132	3000	132DP30	17.5	2000	1000	60 x 102	84 x 124	5C	14 / 47	2850
	6000	132DP60	20	2500	1200			8 / 84	3650	
	9000*	132DP90	22	3000	1500	60 x 106	84 x 128	5V*	8 / 82	5300
	12000*	132DP120	24	4000	1500			6050		
144	3000*	144DP30	18.75	2000	1000	72 x 108	96 x 132	5C	11 / 64	3450
	6000*	144DP60	21	2500	1200			5V*	7.5 / 93	4000
	9000*	144DP90	23	3000	1500	72 x 113	96 x 136	5V(HT)*	8 / 91	5950
	12000*	144DP120	25	4000	1500			6700		

STD. Power Unit = Internal
* Remote PU (5V=5HP Vert)

*** Single Cylinder

*Remote PU 5V(HT)= High Travel Tank

LOAD CAPACITY

The load capacity rating is stamped on a metal nameplate that is attached to one side of the lift Leg assembly. This load capacity rating is a net rating for a lift furnished with the standard minimum platform. Each platform size listed above in Lift Specifications is the Standard (Minimum) platform size for each model lift. The relief valve on the power unit has been set to raise the lift capacity, plus a small amount for overload. When gravity roller conveyors, fixtures, or special tops, etc, are installed on the lift platform, after leaving the plant, deduct the weight of these components from the load rating to obtain the net lifting capacity.

SPECIFICATIONS



CAUTION!

Lifts should not be overloaded beyond the established capacity as damage and/or personal injury may result and will void its warranty.



DANGER!

Do not make modifications to the lift without authorization from the manufacturer. Autoquip cannot foresee and is not responsible for injury or damage which results from the unauthorized modifications or misuse of the lift.

UNBALANCED LOADING

The stabilization provided is basically for balanced loads. If special attachments extend beyond the length and/or width dimensions of the platform, the end and/or side load capacity must be reduced (contact an Autoquip Sales representative).

LIFT DUTY

Autoquip standard lift designs as described in the specifications typically include intermittent duty motors and are designed to “cycle” (one complete “up” and one complete “down” lift operation) no more frequently than every two minutes – or approximately 60,000 times (cycles) per year. This is considered “normal” duty.

It is the responsibility of the user to notify Autoquip whenever a specific application is likely to demand “above normal” duty from the lift - in excess of 60,000 cycles per year. Above normal duty typically requires supplemental design features to enhance the serviceable life of the lift & to avoid loss of warranty.

PUMP PRESSURE

This lift incorporates a positive displacement pump machined to a high degree of accuracy and specially adapted to requirements of higher-pressure ranges over that of a standard pump. Therefore, standard factory models of the same manufacture cannot replace it.

The pump can operate efficiently at intermittent pressures up to 3200 PSI and continuous duty to 2500 PSI. The safety relief valve in the pump assembly or Deltatrol Valve is factory-set to stay within the parameters of the pump and lift requirements.

LIFT BLOCKING INSTRUCTIONS



WARNING !

Only authorized personnel should perform inspection or maintenance and service procedures. Unauthorized personnel attempting these procedures do so at the risk of personal injury or death.



DANGER !

Failure to properly adhere to lift blocking procedures is to risk the sudden and uncontrolled descent of the lift during maintenance or inspection. A falling lift can cause severe injury or death.

LIFT BLOCKING PROCEDURE – (Reference Figures: 2A & 2B)

This procedure describes the only factory-approved method of working under a lift. Follow these instructions EVERY time you plan to reach or crawl beneath the lift to perform service or maintenance – no matter how momentary that might be.

If the factory-provided maintenance device is damaged or missing, stop immediately and consult the factory for assistance. The manufacturer is not liable for your failure to use the approved maintenance devices and procedures that have been provided.

1. All loads must be removed from the lift prior to engaging the maintenance device. The maintenance device is designed to support an unloaded lift only. Failure to remove the load from the lift prior to blocking could cause the failure of the maintenance device and allow the lift to fall unexpectedly. This can result in personal injury or death, or permanent damage to the maintenance device and/or the lift.
2. Raise the lift to its fully raised position. If you do not, the maintenance device may not be able to be placed properly in its designed blocking position.
3. Locate and engage all maintenance devices.
 - a. **Flip-over maintenance locks** are permanently welded on the side the base frame on the roller end of the lift base frame. Both locks must be flipped over and resting inside the base frame and thus blocking the path of the base rollers. (See Figure 9A).

LIFT BLOCKING INSTRUCTIONS

LIFT BLOCKING PROCEDURE– (Reference Figures: 9A & 9B)

- b. **Maintenance leg** is connected to the base frame by a chain. Remove the maintenance leg from its storage location. Place one end of the maintenance leg in the leg socket located in the base frame on the Clevis End, (See Figure 9B). Lower the lift platform until it comes down and makes contact with the maintenance leg. The maintenance leg should be centered in the platform maintenance leg socket, located underneath the platform on the Clevis End. Re-check to ensure that the maintenance leg device is inside the platform maintenance socket and in contact with the platform deck surface. If the maintenance leg is not fully engaged the lift could fall unexpectedly, resulting in permanent damage to the devices or the lift.



DANGER !

Do not work under lift, without Maintenance Device! To avoid personal injury, NEVER go under the lift platform until the load is removed and the scissors mechanism is securely blocked in the open position and the appropriate OSHA lock-out/tag-out procedure is followed. See "Lift Blocking Instructions" section.



DANGER !

If for any reason you are unable to lower the lift completely onto the maintenance device(s), stop immediately and consult the factory. Failure to properly use the factory approved maintenance device(s) could result in severe injury or death.

4. Once the maintenance device(s) is properly and securely engaged continue to press the down button for an additional 5-10 seconds to relieve all pressure in the system (it could take longer in a pneumatic system).



WARNING !

Failure to relieve the system operating pressure could result in the sudden and unexpected release of high-pressure fluids (or air) during maintenance and/or repair of the lift and result in severe injury or death.

LIFT BLOCKING INSTRUCTIONS

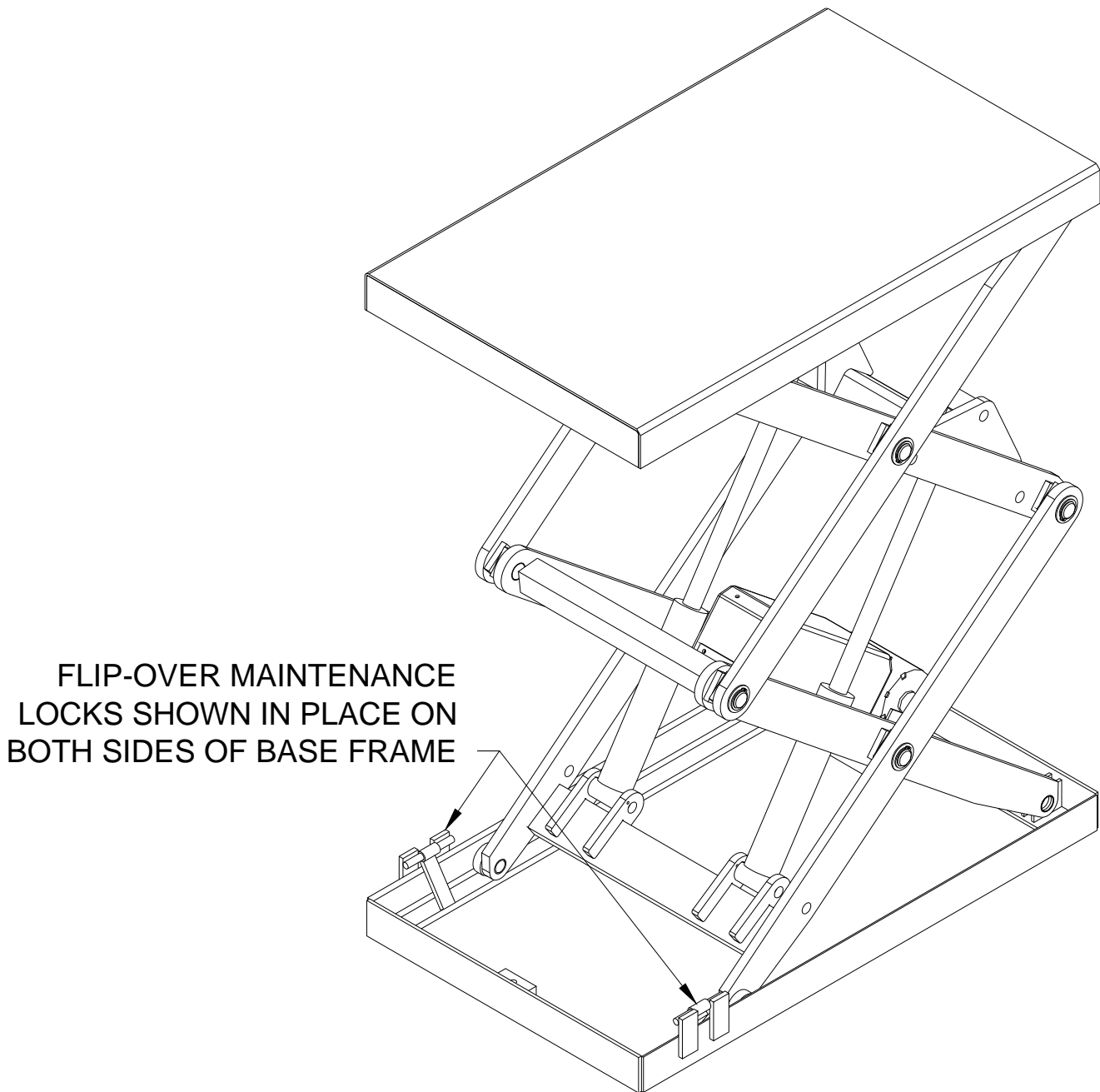

Figure 2A: Flip-Over Maintenance Locks

LIFT BLOCKING INSTRUCTIONS

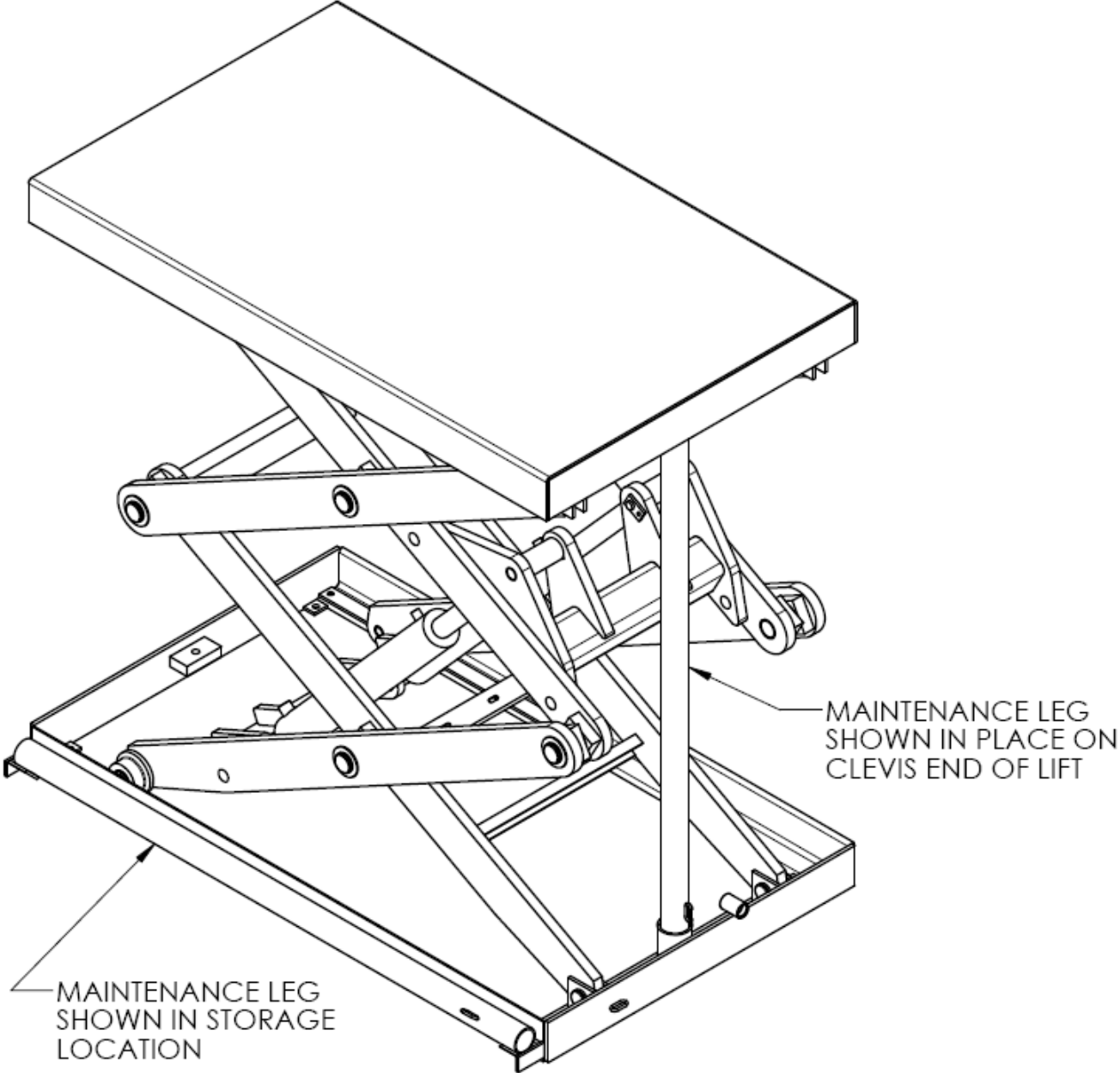

Figure 2B: Maintenance Leg – High Capacity or High Travel Models

LIFT BLOCKING INSTRUCTIONS

LIFT BLOCKING PROCEDURE– (continued)

5. Follow OSHA electrical lock-out/tag-out procedures. Disconnect and tag all electrical and/or other power sources to prevent an unplanned or unexpected actuation of the lift.
6. Once inspection or work is complete reverse steps 1-5 above, raise the lift off the maintenance device and place the maintenance device back into the designated storage position.

INSTALLATION INSTRUCTIONS



WARNING!

Before installing the lift, read & follow the recommended safety practices in the Safety Practices section. Failure to follow these safety practices could result in death or serious injury

FLOOR INSTALLATION

1. Make sure the installation area is clean before starting. Check the mounting surface of the floor with a level or straight edge. If the floor is not level, add shims or grout under the lift base frame along the entire perimeter of the base to achieve a level and flat base installation. A level base will ensure proper wheel tracking and smooth lift operation.
2. If the permanent electrical work is not complete, some means of temporary lines with an on-off device for the power supply should be set up for testing purposes.
3. Place the lift in the installation area and level the base frame per note #1.

NOTICE !

When moving the lift, do not attempt to pick it up by the platform, the platform is hinged and could be damaged. Pick up the lift from under the base frame ONLY using a strap sling.

4. Make temporary electrical connections and permanent hydraulic connections. Raise the lift approximately one foot using the “UP” button. Then lower the lift back to fully collapse, holding the “DOWN” button for approximately 60 seconds. Repeat this process five to seven times to bleed any air out of the hydraulic system.



DANGER !

HIGH VOLTAGE!! – Disconnect and/or lock out the electrical supply to the power unit per OSHA regulations prior to any installation or maintenance being performed.

5. Raise the lift to the top of its travel and make positioning adjustments. Check for the proper height. If needed, shim to the desired height. DO NOT “spot” shim. Shim the full length of the base frame. This will prevent the frame from sagging under an exceptionally heavy load.

INSTALLATION INSTRUCTIONS



DANGER!

Do not work under the lift without use of the Maintenance Device! To avoid personal injury, NEVER go under the lift platform until the load is removed and the scissors mechanism is securely blocked in the open position and the appropriate OSHA lock-out/tag-out procedure is followed. See "Lift Blocking Instructions" section.

6. The base frame of the lift has pre-drilled holes for lagging it securely to the floor. Mark the holes, drill, and install with anchors. Lifts with oversize platforms have minimum pull out requirements of 2,000 lbs. for each anchor.
7. Make permanent electrical connections and operate the lift through a few cycles.

REMOTE POWER UNIT INSTALLATION:

1. The remote power unit is to be located in an area protected from the elements and should be installed prior to the lift to facilitate lift operation during installation into the pit.
2. The remote contractor power unit is equipped with power unit mounting brackets and can be wall or floor mounted using these brackets. If equipped with a vertical power unit, optional power unit mounting brackets must be used for wall mounting. (Contact Autoquip for optional 'vertical power unit' brackets).
3. The electrical work is to be done in accordance with local codes by a qualified electrician. See the "General Maintenance" section for the standard wiring diagram.
4. If permanent electrical work is not complete, some means of temporary power with an on/off device for the motor will be required.
5. Fill the reservoir with oil per instructions in the "Routing Maintenance" section.

INSTALLATION INSTRUCTIONS

LIFT & HOSE INSTALLATION – (Reference Figure 3A & 3B)



CAUTION!

Precautions should be taken to prevent the introduction of contaminants such as dirt or other foreign material into the hydraulic system through open fittings, pipes or disassembled components. Contamination will ruin the hydraulic system.

1. Make temporary hose connections with high-pressure hose (see chart below) to allow the lift to be operated when it is set in the pit.

Hydraulic Piping/Hose Size

Up to 25 feet	1/2" ID
26 feet to 50 feet	3/4" ID
Over 50 feet	1" ID

2. Using 3/4"--10 UNC lifting eyebolts and a chain spreader to place the lift into the pit as illustrated in Figure 11.
3. Remove the shipping bolt and lifting eye bolts before operating the lift. Failure to remove the shipping bolts before operating the lift will cause permanent damage to the lift.

INSTALLATION INSTRUCTIONS

PIT INSTALLATION – Platforms with Bevel Toe Guards **(Reference Figure 3A & 3B)**



DANGER!

Do not install the lift in a pit unless it has a bevel toe guard or other approved toe protection. Failure to provide approved toe protection could result in exposure to shear points and potential severe injury to personnel.

Lift platforms traveling below floor levels may create openings, and the shape of the load and how the load is arranged on the lift may create a toe hazard as the load passes the top edge of the pit. Both situations may require guarding in accordance with Federal Regulations. Any such guarding must be installed prior to operating the lift.

PIT DIMENSIONS:

1. Check the pit dimensions. The overall length and width should be 2" (minimum) longer and 2" (minimum) wider than the lift platform. Pit depth should be the Lift Lowered Height plus 1/2" for shims or grout. The pit, in which the lift is installed, is the responsibility of the contractor or owner.
2. Make sure the installation area is clean before starting. Check the mounting surface of the pit floor with a level or straight edge. If the floor is not level, add shims or grout under the lift base frame along the entire perimeter of the base to achieve a level and flat base installation. A level base will ensure proper wheel tracking and smooth lift operation.
3. Check the chase (3" conduit) entrance into the pit. If the permanent electrical work is not complete, some means of temporary lines with an on-off device for the motor should be set up for testing purposes.
4. Lower the lift into the pit and check for proper height. The lift should be flush with the pit angle framing. If needed, shim to the desired height. DO NOT "spot" shim. Shim the full length of the base frame. This will prevent the frame from sagging under an exceptionally heavy load.

INSTALLATION INSTRUCTIONS

PIT INSTALLATION – Platforms with Bevel Toe Guards **(Reference Figure 3A & 3B)**

NOTICE !

When moving the lift, do not attempt to pick it up by the platform; it is hinged and could be damaged. Pick up the lift from under the base frame ONLY using a strap sling.

5. Make temporary electrical connections and permanent hydraulic connections. Raise the lift approximately one foot using the “UP” button. Then lower the lift back to fully collapse, holding the “DOWN” button for approximately 60 seconds. Repeat this process five to seven times to bleed any air out of the hydraulic system.
6. Raise and lower the lift to make positioning adjustments and align the platform in the pit with a proper clearance of 1" minimum between the platform edge and the pit curb angle.



DANGER!

Do not work under lift without Maintenance Device! To avoid personal injury, NEVER go under the lift platform until the load is removed and the scissors mechanism is securely blocked in the open position and the appropriate OSHA lock-out/tag-out procedure is followed. See "Lift Blocking Instructions" section.

7. The base frame of the lift has pre-drilled holes for lagging it securely to the floor. Mark holes, drill, and install with anchors. Lifts with oversize platforms have minimum pull out requirements of 2,000 lbs. for each anchor.
8. Make the permanent electrical connections and operate the lift through a few cycles.

INSTALLATION INSTRUCTIONS

CLEAN UP

1. Clean up any debris from the area. A clean installation makes a good impression and creates a much safer environment!
2. Touch-up paint is available from *Autoquip* for repair of damaged paint surfaces.



WARNING!

All DANGER, WARNING, and CAUTION labels and informational decals and plates must be intact and in place on the lift. Contact an Autoquip representative if labels are missing or damaged. See “Label Identification” section of this manual.

INSTALLATION INSTRUCTIONS

82601770

NOTES:

1. ALL AXLES, ROLLERS AND PIVOT POINTS ARE EQUIPPED WITH LIFE-TIME LUBRICATED BEARINGS.
2. LIFT TO BE PAINTED AQ STANDARD ENAMEL.
3. MEETS OR EXCEEDS ANSI MH29.1 STANDARD FOR INDUSTRIAL SCISSORS LIFTS.

THIS PROPOSAL DRAWING IS GENERIC BY DESIGN AND IS FOR REFERENCE ONLY. PLEASE CONTACT AUTOQUIP FOR JOB SPECIFIC APPROVAL DRAWINGS.

MODEL NO: _____

MAX CAPACITY: _____

LOWERED HEIGHT: _____

TRAVEL: _____

RAISED HEIGHT: _____

POWER UNIT, CONTROLS, AND ACCESSORIES PER QUOTATION.

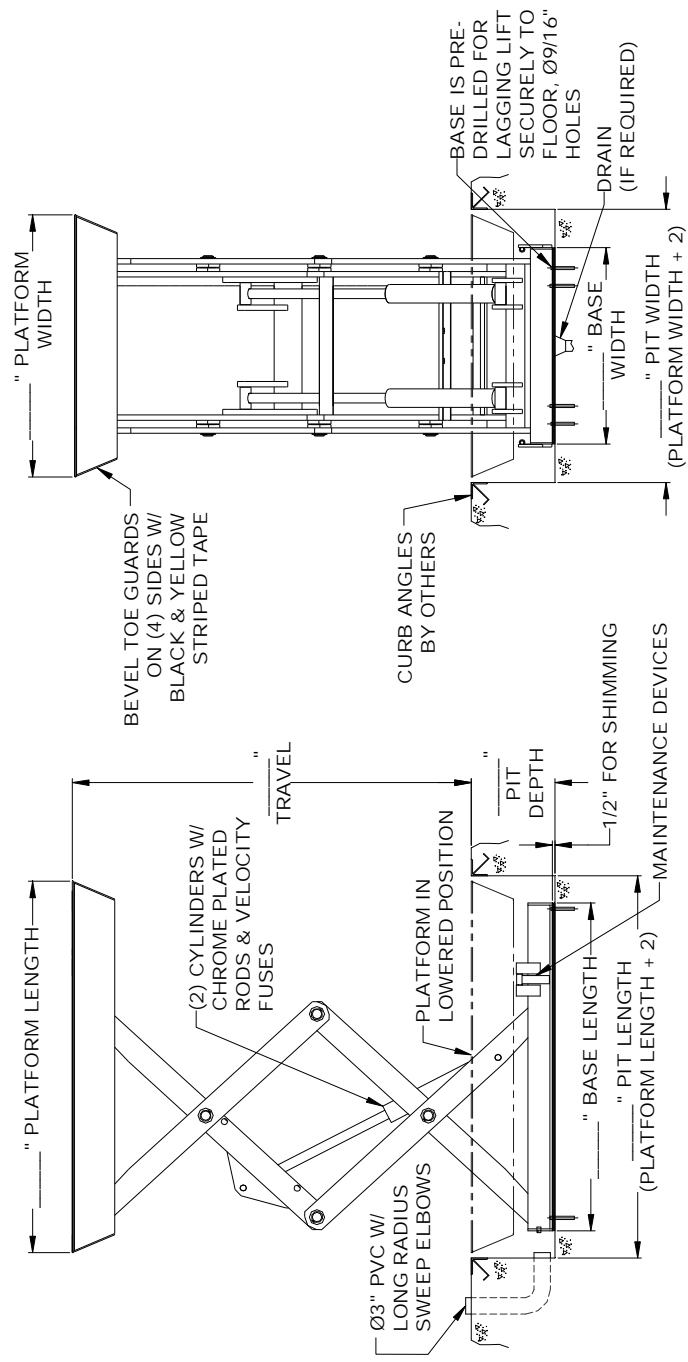

DOUBLE PANTOGRAPH (DP) LIFT PIT MOUNTED

(NOT TO SCALE)

**PROPOSAL DRAWING
QUOTE NO.** _____

82601770

AUTOQUIP CORP.
1058 W. INDUSTRIAL AVE.
GUTHRIE, OK 73044-1058
888-811-9876 WWW.AUTOQUIP.COM

© COPYRIGHT RESERVED
AUTOQUIP CORPORATION

Figure 3A: Pit Drawing

INSTALLATION INSTRUCTIONS

A 1/2" NPT FEMALE FITTING IS PROVIDED ON CLEVIS END OF BASE ASSEMBLY FOR CONNECTION OF CONNECTING HOSE.

(2) 3/4"-10 UNC LIFTING EYES (BY INSTLLER). TO FIT IN TAPPED HOLES IN PLATFORM.

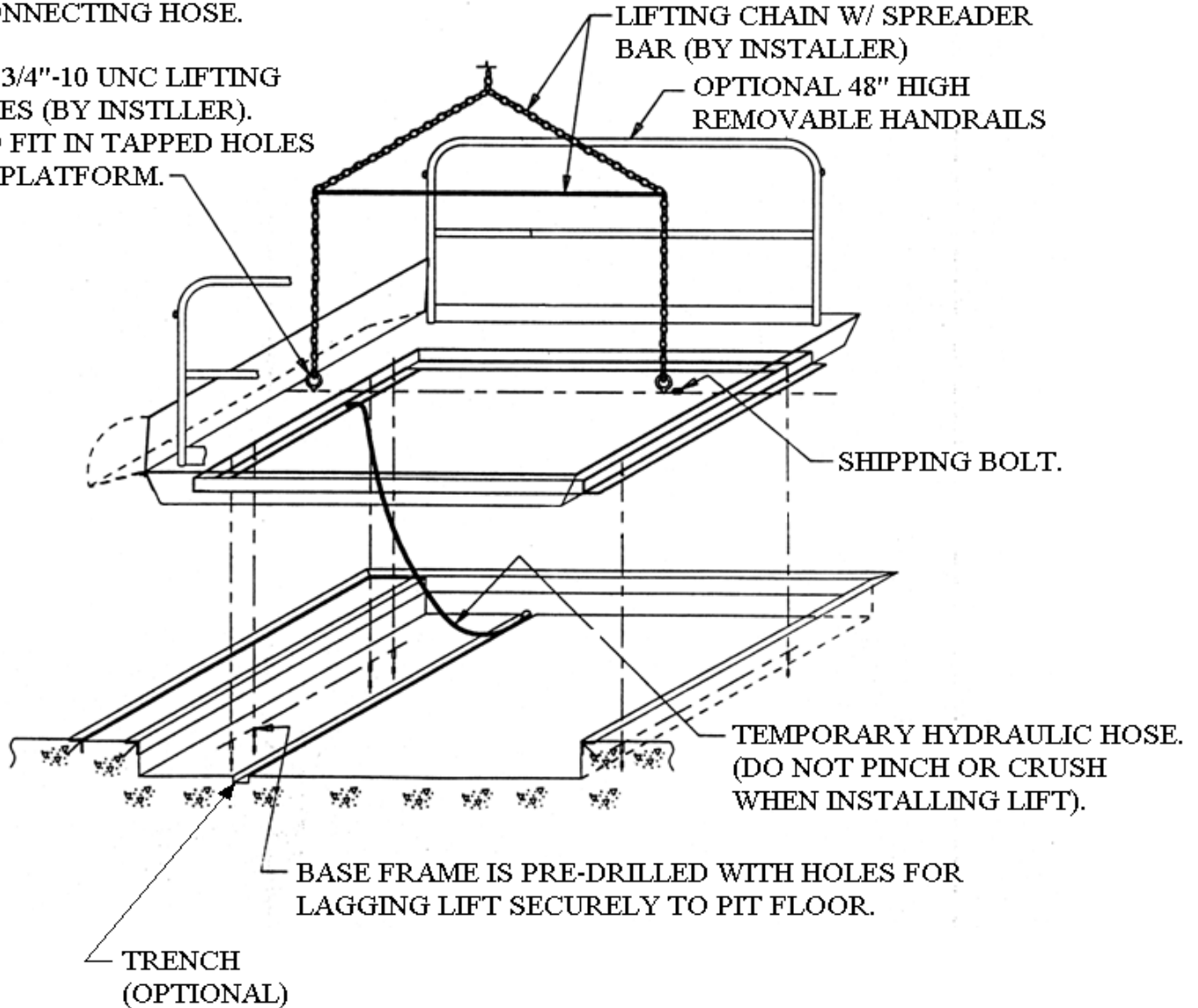

Figure 3B: Lifting and Installation

INSTALLATION INSTRUCTIONS

LEVELING TO GRADE: – (Reference Figure 3A & 3B)

1. The platform top should be solid and flush with the pit curb angles. The pit depth includes 1/2” added to the lowered height of the lift for leveling purposes (see Figure 10 and 11).
2. Fully lower the lift platform into the pit and check for proper height.
3. Shims and/or grout must be placed under the entire base frame assembly and the platform support members to support the platform top at grade level. DO NOT “spot” shim! Shims and/or grout must be able to support the lift base frame while loaded at full rated lifting capacity and rollover load.



CAUTION!

The Contractor or Owner is responsible for removal of the Shipping Bolt and Lifting Eye Bolts prior to operating the lift. Failure to remove the Shipping Bolt before operating the lift will cause permanent damage to the lift.

STARTING UP AND LAGGING DOWN:

1. Check the routing of the temporary hydraulic lines to assure that the hose is clear of legs, base frame, and platform when lift is in the lowered position.
2. Make positioning adjustments of the lift to align the platform with a 1” clearance around the edges of the pit.
3. Make temporary electrical connections and permanent hydraulic connections (refer to **Hydraulic Piping/Hose Size** chart above). The female end connection on the lift base frame is 1/2” NPT.
4. For remote power units, a (optional) connecting hose must be used for connecting the remote power unit to the lift. Simply thread one end of the high pressure hose into the power unit fitting and into the coupling located in the base frame. **NOTE: Use pipe dope at all connections – DO NOT USE TEFLON TAPE.**
5. Raise the lift approximately one foot using the “UP” button (**Caution:** Do not raise the lift to its full travel until all the air has been bled from the system. It is very difficult to lower the lift if the velocity fuses engage while the lift is fully raised). Then lower the lift back to fully collapse, holding the “DOWN” button for approximately 60 seconds. Repeat this process five to seven times to bleed any air out of the hydraulic system while confirming that the alignment of the lift in the pit is acceptable.

INSTALLATION INSTRUCTIONS

STARTING UP AND LAGGING DOWN - continued:

6. Raise the platform and install the maintenance device (see “Lift Blocking Instructions” section).
7. Lag down the base frame in the holes provided. Lag bolts should be able to withstand 2000 lbs. minimum upward pull at each corner.
8. Replace any electrical connections with permanent.

FINAL PREPARATION:

1. Place the optional handrails in the platform sockets as shown in Figure 3B.
2. Be sure the maintenance device is securely in its storage position.
3. Check oil level of reservoir with the lift in the fully lowered position. Oil should be 1” to 1-1/2” below the top of the reservoir tank. (See the “Maintenance” section for oil specifications.)
4. Make sure that all applicable labels are in place in accordance to Figure 1.



WARNING!

All DANGER, WARNING, and CAUTION labels and informational decals and plates must be intact and in place on the lift. Contact an Autoquip representative if labels are missing or damaged.

CLEAN UP:

1. Clean up any spilled oil and debris from the area. A clean installation makes a good impression and creates a much safer environment!
2. Touch-up paint is available by request from *Autoquip* for repair of damaged paint surfaces.

INSTALLATION INSTRUCTIONS

SKIRT INSTALL PROCEDURE FOR A LIFT ORDERED WITH AN ACCORDION SKIRT – (Reference Figure 4)

1. Position the platform in the raised position. Install the maintenance locks (see “Lift Blocking Instructions” section). Remove the handrails. Position the accordion with the weight rod pocket at the bottom and the mounting collar at the top. The breathable material when provided must be positioned at the top of the skirt with the mounting collar.
2. Slip the skirt over the end of the platform. Turn the skirt as required to slide over the other end of the platform and leg assembly. The skirt should be in position under the platform while enveloping the base assembly.
3. See Skirt Dwg. Figure 4 and select the correct mounting configuration, (Number 1, 2, or 3).

SIDE MOUNTING (Skirt Install Figure #1): Mounting an Accordion Skirt On the Platform Side. Raise one side of the skirt along with a (1/8” x 1”) skirt -mounting bar to (1) side of the platform. When possible, center the skirt-mounting collar and the (1/8” x 1”) skirt-mounting bar on the platform side. Align the pre-drilled holes in the side of the platform with the skirt-mounting bar holes and punch holes in the skirt-mounting collar. Push a nylon drive rivet through each hole in the skirt-mounting bar. Hammer the aluminum pin into the rivet until flush with the rivet head. Repeat mounting process for the remaining sides of the accordion skirt.

UNDERNEATH MOUNTING (Skirt Install Figure #2): Mounting an Accordion Skirt Underneath the Platform. Raise one side of the skirt along with a (1/8” x 1”) skirt-mounting bar to the underside of the platform skirt support bar. When possible, center the skirt mounting collar and the (1/8” x 1”) skirt-mounting bar on the platform support bar. Align the pre-drilled holes in the skirt support bar (picture frame) with the skirt -mounting bar holes and punch holes in the skirt-mounting collar. Push a nylon drive rivet through each hole in the skirt-mounting bar. Hammer the aluminum pin into the rivet until flush with the rivet head. Repeat mounting process for the remaining sides of the accordion skirt.

TOE GUARD MOUNTING (Skirt Install Figure #3): Mounting an Accordion Skirt Onto the Bevel Toe Guard. Raise one side of the skirt along with a (1/8” x 1”) skirt-mounting bar to the side of the bevel toe guard. When possible, center the skirt mounting collar and the (1/8” x 1”) skirt-mounting bar on the platform bevel toe guard. Align the pre-drilled holes in the bevel toe guard with the skirt-mounting bar holes and punch holes in the skirt-mounting collar. Push a nylon drive rivet through each hole in the skirt-mounting bar. Hammer the aluminum pin into the rivet until flush with the rivet head. Repeat mounting process for the remaining sides of the accordion skirt.

4. Install weight rods into the weight rod pockets at the bottom of the accordion skirt. Install the spring tempered wire rods into the pocket of black convolutions.

INSTALLATION INSTRUCTIONS

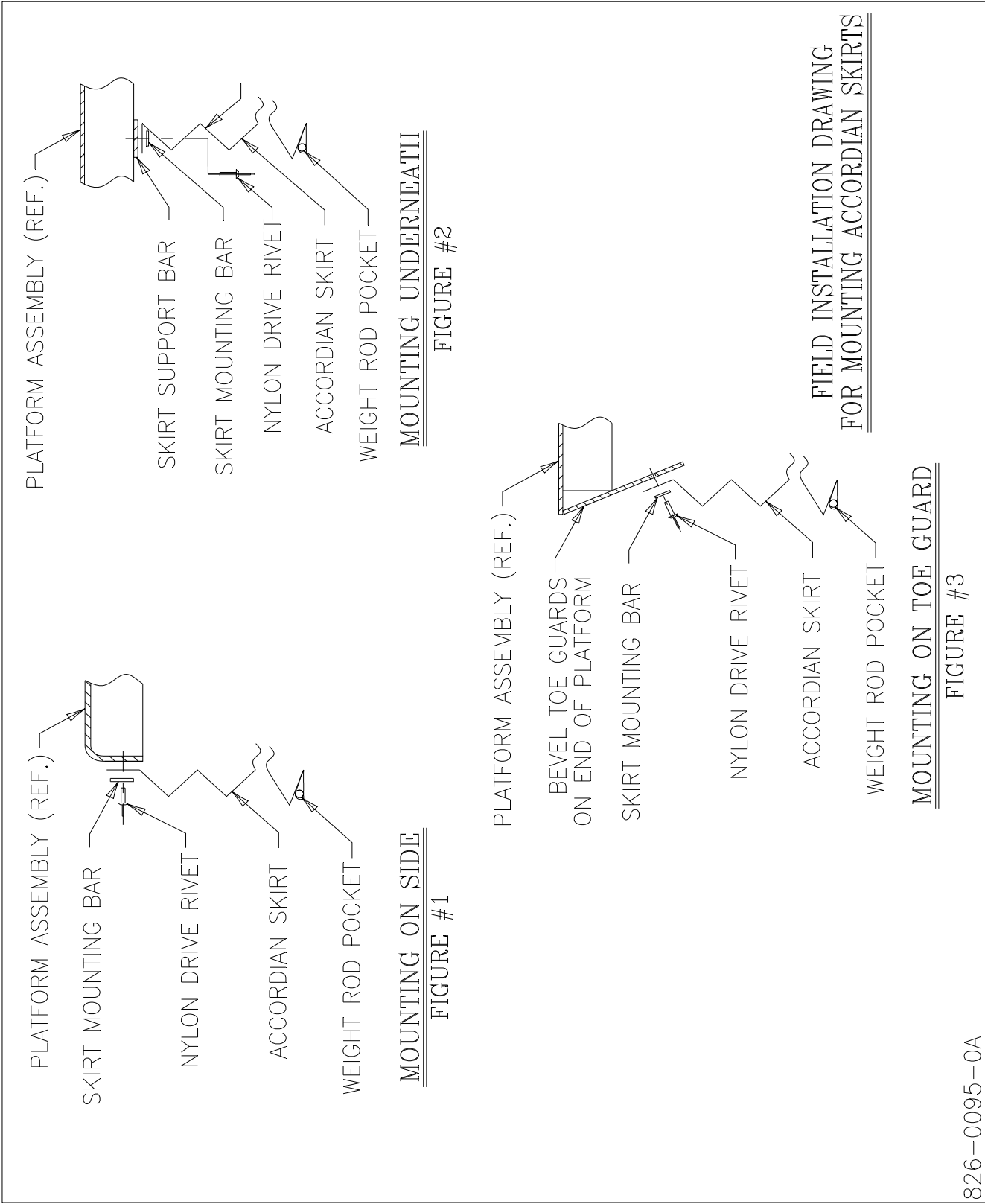

Figure 4: Accordion Skirt Installation

OPERATING INSTRUCTIONS



WARNING !

Familiarize yourself with this operator's manual before operating this equipment. Only trained and qualified personnel should operate this equipment.

1. Scissors lifts have maximum lifting capacity ratings (see "Specifications" section). The safety relief valve has been factory set to open at a pressure slightly above the rated load capacity and allows the oil to bypass into the reservoir to prevent damage to the lift and its hydraulic power unit. **The safety relief valve should not be adjusted for any reason as it could cause the motor to prematurely burn out.** Applying loads exceeding the rated capacity of the lift may result in excessive wear and damage to the lift.
2. This type of lift is designed primarily for inplant applications and is typically furnished with constant pressure pushbutton (or foot switch) controls. Actuating the "UP" button will cause oil to enter the cylinders and the lift will rise.
3. When the desired height or upward travel of the platform is attained, removing the operator's hand or foot from the switch deactivates the "UP" circuit button. The oil stops flowing and the upward movement will stop.
4. To lower the lift, activate the "DOWN" button. Opening the down control valve allows the oil in the cylinders to flow through the down valve at a controlled rate and return oil to the reservoir.
5. When the desired height or downward travel of the platform is attained, removing the operator's hand or foot from the switch deactivates the "DOWN" circuit. The oil stops flowing from the cylinders and the downward movement will stop.



WARNING !

Personnel should always maintain a safe operating distance of at least 36" any time the lift is operated up or down.

NOTICE!

Do not operate the power unit on relief for more than a few seconds. When on relief, the valve will make an audible squealing sound.

ROUTINE MAINTENANCE



WARNING!

Before maintaining lift, read & follow the recommended safety practices in the Safety Practices section. Failure to follow these safety practices could result in death or serious injury.

THROW-OVER BRIDGE



WARNING !

Any lift which has a hinged throw-over bridge damaged to the point of hanging more than 30 degrees below horizontal is in violation of the safety standards set forth in ANSI MH29.1 and MUST be taken out of service until the bridge is repaired or replaced. Failure to do so could result in severe personal injury or permanent damage to the lift.



DANGER!

Do not work under lift without Maintenance Device! To avoid personal injury, NEVER go under the lift platform until the load is removed and the scissors mechanism is securely blocked in the open position and the appropriate OSHA lock-out/tag-out procedure is followed. See "Lift Blocking Instructions" section

ROUTINE MAINTENANCE

Daily Inspection List (10 hours of operation):

- Check reservoir fluid level.
- Check all hydraulic hoses and electrical cords for cracks, abrasions, twisting, etc. Small leaks at connections can be remedied by tightening connections or replacing the faulty component.
- Check that hydraulic pressure does not exceed 3,000 psi.
- Check overall condition of unit (i.e. bends, breaks, loose or missing screws, etc.).

Monthly Inspection (100 hours of operation):

Normally scissors lifts will require very little maintenance. However, a routine maintenance program could prevent costly replacement of parts and/or downtime.

- Check quality of oil in reservoir. Replace if it becomes discolored (oxidized), cloudy, or otherwise contaminated. Factory recommended fluid is **SAE 5W30 motor oil**. DO NOT OVERFILL. Always use clean oil.
- Inspect lift cylinder rods for scoring and leaking, wipe away any foreign material.
- Inspect all structural and mechanical components for cracked or broken welds and any distortion caused by collision, overloading, or other misuse.
- Inspect snap rings/bolts at all rollers & pivot points for proper retention & tightness.
- Inspect retainer bolts which capture cylinder trunnion pins for proper retention.
- Check all rollers for signs of wear. Replace as necessary. Do not grease roller or axles; they have lifetime-lubricated bearings.
- Check all wiring for loose connections or wear. Repair at once.
- Check for damage on all hinged, throw-over bridges. Any lift which has a damaged bridge, to the point of hanging more than 30 degrees below horizontal is in violation of safety standards as set forth in ANSI MH29.1 and MUST be taken out of service until the bridge is repaired or replaced.

When all above checks have been completed start unit and operate through all functions. Inspect all components for signs of noise, vibration, erratic movement, and any other abnormal behavior.

Annual Inspection (1000 hours of operation):

- Drain oil in reservoir and clean reservoir as needed. Always fill reservoir with **New SAE 5W30 motor oil**. Never fill reservoir with used oil or excess oil from a drip pan or pit. Dispose of and handle the used or excess oil as a hazardous material.
- If noise or vibration has been noticed, remove lift cylinder pins, pivot pins, and roller bearings. Inspect for wear and replace as necessary.
- Replace any hydraulic hose that shows signs of chafing or leaking.
- Replace suction filter.
- Check for permanent mechanical deformation.

ROUTINE MAINTENANCE

OIL REQUIREMENTS:

Change oil yearly or more frequently if it darkens materially or feels gummy or gritty. Check oil for the presence of water, (oil will turn milky in color). Do not use hydraulic-jack oil, hydraulic fluids, brake fluids, or automatic transmission fluid.

OIL RECOMMENDATIONS

Hydraulic lifts operate efficiently utilizing high quality oil products that are readily available in all areas. These oil products contain additives that are desirable for optimum performance of the equipment. Follow the recommendations below that apply to the circumstances most similar to your installation.

Environment (Ambient Temperature)	Recommended Oil
Indoor locations with variable temperatures: 30 - 100 degrees F	5W30 or 5W40 Multiviscosity Motor Oil
Indoor locations with constant temperatures: 60 - 80 degrees F	SAE 20 Motor Oil
Outdoor locations: 30 - 120 degrees F	5W30 or 5W40 Multiviscosity Motor Oil
Outdoor locations: 10 degrees F below 0 to 100 degrees F	5W20 or 5W30 Multiviscosity Motor Oil
Cold Storage Warehouse: 10 - 40 degrees F	Contact local <i>Autoquip</i> Service Rep.

NOTE: Oils listed above are detergent type oil.

OIL CAPACITY

*Contractor Polyethylene Tank: Oil capacity is approximately: (5.5) gallons or (22) quarts.

*Vertical Steel Tank: Oil capacity is approximately: (10) gallons or (40) quarts.

*Large Vertical Steel Tank: Oil capacity is approximately: (12) gallons or (48) quarts.

*The oil level in the Contractor or Vertical reservoir should be 1" below the top of the reservoir with the lift in the fully lowered position.

ROUTINE MAINTENANCE

NOTICE!

Use approved fluids only! Use of unauthorized fluids may cause damage to seals and hosing.

DO NOT USE:

1. Automatic Transmission Fluid (ATF)
2. Hydraulic Jack Oil
3. Hydraulic Fluids
4. Brake Fluids

Standard Factory recommended fluid is **SAE 5W30 motor oil**. See Oil Recommendations on previous page.

BLEEDING AIR FROM THE SYSTEM

1. Bleed any air which may have been entrapped in the hydraulic system by raising the lift to approximately 50% of its full travel, then lower back down completely.
2. Hold the "DOWN" button for approximately 60 seconds.
3. Repeat this process five or six times.
4. Should the above steps not correct the problem, contact *Autoquip* to obtain instruction for further action.
5. Clean up any spilled oil. Used oil should be discarded as it may contain flushed contaminants from the line.

GENERAL MAINTENANCE



WARNING!

Before maintaining lift, read & follow the recommended safety practices in the Safety Practices section. Failure to follow these safety practices could result in death or serious injury.



DANGER!

Do not work under lift without Maintenance Device! To avoid personal injury, NEVER go under the lift platform until the load is removed and the scissors mechanism is securely blocked in the open position and the appropriate OSHA lock-out/tag-out procedure is followed . See "Lift Blocking Instructions" section



DANGER !

Failure to relieve lift table system pressure could result in the sudden and unexpected release of pressure during maintenance and/or repair of the lift and result in severe injury to personnel and/or damage to the lift.

1. NEVER TRY TO DISASSEMBLE OR REPAIR A PUMP IN THE FIELD. These pumps are high-precision devices requiring extreme precision in fit-up. When one is damaged, there is seldom anything that can be repaired in the field. It is also more economical to replace a pump than to refit old parts with new parts.
2. The roller pin or roller bushing should be replaced whenever excessive wear is detected. The rollers are furnished with a pressed-in lifetime-lubricated bushing.

PIPE THREAD SEALANT

Loctite PST #567 pipe thread sealant or equivalent is recommended. **Do not use Teflon tape.** Tape fragments can cause malfunctioning of the hydraulic system.

GENERAL MAINTENANCE

The following should be referenced in connecting the standard heavy-duty motors to power sources. Remember that heavy wire must be used all the way to the power source.

HP and Voltage	Full Load Amperages	
3 HP: 115 / 208 / 230V /60 CY/1PH Vertical Motor (Not Super Torque)	115 V = 33.6 Amps	208/230V =16.8 Amps
5 HP: 230 V /60 CY/1 PH Vertical Motor (Not Super Torque)	230 Volts = 24.5 Amps	
5 HP: 208 / 230 V /60 CY/3 PH Contractor Motor (Super Torque)	208 V =15.8 Amps	230 V =14.8 Amps
5 HP: 460 V /60 CY/3 PH Contractor Motor (Super Torque)	460 Volts = 7.4 Amps	
5 HP: 208 / 230 V /60 CY/3 PH Vertical Motor (Super Torque)	208 V =16 Amps	230 V =15.2 Amps
5 HP: 460 V /60 CY/3 PH Vertical Motor (Super Torque)	460 V =7.6 Amps	

MOTOR CONNECTION DIAGRAMS

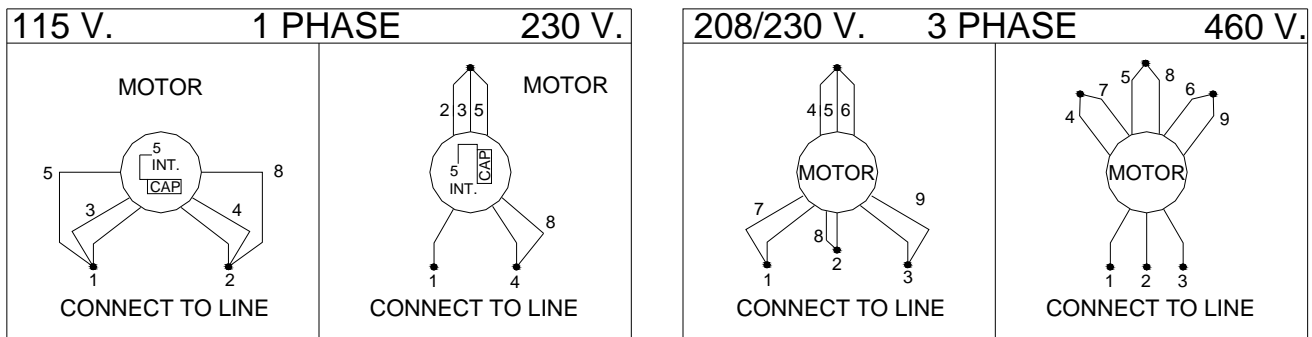

Figure 5: Motor Wiring Diagrams

GENERAL MAINTENANCE



DANGER !

HIGH VOLTAGE!! – Disconnect and/or lock out the electrical supply to the power unit per OSHA Lock-Out, Tag-Out procedures prior to any installation or maintenance being performed.

POWER UNIT WIRING – (Reference Figure 5)

CONTRACTOR REMOTE POWER UNIT:

1. The Contractor Power Unit utilizes a 5 HP / 208-230-460 Volt / 60 hertz / 3 phase "Super-Torque" intermittent duty motor with (one full lift cycle per 2 minute period) driving a high pressure positive displacement pump assembly with an internal relief valve, check valve and down solenoid valve.
2. Because *Autoquip* "Super-Torque" motor actually delivers substantially more horsepower than the nameplate rating, it must always be wired for heavier current-draw than standard motors of the same nameplate rating. However, because of the "Super-Torque" motor's starting efficiency and superior running characteristics, circuit components do not have to be as large as for standard motors of equal delivered horsepower.

VERTICAL REMOTE POWER UNIT:

1. The Vertical 'HD' Power unit utilizes a 5 HP/ 208-230-460 Volt / 60 hertz / 3 phase Heavy Duty motor, (with a 30 minute continuous duty rating). The power unit is coupled with a high-pressure positive displacement gear pump, and *Autoquip Corporation's* patented Deltatrol valve assembly.
2. The vertical power unit is also available with a 5 HP/ 230 Volt/ 60 hertz / 1phase motor or a 3 HP/ 115 Volt / 60 hertz/ 1phase motor as an option. These motors are not Super Torque motors. These motors coupled with a high-pressure positive displacement gear pump, and *Autoquip Corporation's* patented Deltatrol valve assembly.
3. The motor connection diagram in Figure 5, should be referenced in connecting the motors to a power source. Remember that heavy wire must be used all the way to the power source.

GENERAL MAINTENANCE



WARNING!

Before maintaining the lift, read & follow the recommended safety practices in the Safety Practices section. Failure to follow these safety practices could result in death or serious injury.



DANGER !

Failure to relieve lift table system pressure could result in the sudden and unexpected release of pressure during maintenance and/or repair of the lift and result in severe injury to personnel and/or damage to the lift.

CYLINDER REMOVAL

1. Raise the lift to its full height and block securely. See “Lift Blocking Instructions”.
2. Press the Down Pushbutton or Down Foot Switch to relieve system pressure.
3. Cut off the electricity to the power unit (lock out-tag out).
4. Disconnect the cylinder hose at the power unit connection fitting, and insert it in the oil fill hole of the reservoir.
5. Loosen the bolt in the Upper cylinder clevis.
6. Secure the cylinder from dropping on the floor using a strap or rope. Remove the cylinder pin from the upper clevis by carefully tapping out the clevis pin. Avoid damaging the clevis pin or bushings.
7. Lower the cylinder and push the piston rod into the cylinder to eject as much oil as possible into the oil container.
8. Loosen the set screw in the Lower cylinder clevis. Remove the cylinder pin from the lower clevis by carefully tapping out the clevis pin. Avoid damaging the clevis pin or bushings.
9. Remove the cylinder from the leg assembly.

GENERAL MAINTENANCE

' PH ' CYLINDER REPACKING (Reference Figure 6)

1. Remove the cylinder as described above in Cylinder Removal.
2. Pull the rod out of the cylinder tube sufficiently to gain access to the 'spanner wrench holes' on the rod end of the cylinder. Do not allow oil or dirt to be pulled back into the hydraulic hose.
3. Insert a Spanner wrench in the upper bearing assembly and turn the bearing assembly counter clockwise until the tip of the retainer ring appears in the slot located on the cylinder outer casing.
4. Insert a small blade screwdriver under the tip of the retainer ring and turn the upper bearing assembly counter-clockwise until the retainer is removed from the slot.
NOTE: The wire retainer ring may be a cutting or puncturing hazard.
5. Pull the rod out of the tube slowly to remove the rod and bearing assembly.
NOTE: Use caution to prevent surface damage to the rod. This could result in seal failure and/or leakage.
6. After all the internal components have been removed, use a bright light to inspect the inner walls of the cylinder barrel. Use a cylinder hone if necessary to remove any apparent nicks or scratches. Clean and flush the barrel thoroughly after honing to remove chips and grit.
7. Remove the piston lock nut and slide off the piston and bearing assembly. Take care to protect the rod surface from damage. The upper trunnion clevis and pin on the Leg assembly may be used secure the cylinder rod and prevent rotation of the rod while loosening the piston lock nut.
8. Inspect all piston grooves and seal surfaces for any imperfections and repair or replace as necessary. Install new packing and seals on the piston, rod, and bearing assembly. See Figure 19.
9. Liberally lubricate the piston and seals with CLEAN grease or oil. Install the seal and piston on the rod assembly. Install the Rod Lock Nut on the rod and torque the Lock Nut to: 325 ft. lbs. on 3.0" Bore, 3.5" Bore & 4" Bore cylinders. On 5" Bore Cylinders, torque the Rod Lock Nut to 350 ft. lbs. The upper trunnion clevis and pin on the Leg assembly may be used to prevent the rotation of the rod while tightening.
10. Again, liberally lubricate the piston and seals with CLEAN grease or oil and install the rod and piston into the cylinder casing tube using care not to damage any seals or packing.

GENERAL MAINTENANCE

' PH ' CYLINDER REPACKING (Reference Figure 6)

11. Slip the bearing assembly into place. Align the retainer hole in the bearing assembly groove with the slot in the tube.
12. Insert the retainer hook end in the hole/slot and using a face spanner wrench. Turn the bearing assembly clockwise until the retainer is completely inserted in the groove/slot in the tube.
13. Check the clevis pin bushings in the cylinder rod for wear and replace as necessary.
14. Pull out the rod end of the cylinder and install the assembled cylinder into the lift. Carefully drive the clevis pin through the trunnion clevis and cylinder rod clevis. Extreme care must be taken to prevent damage to the clevis bushings. Install the set screw, (engaging the slot in the pin), and torque to 25 ft. lbs. The cylinder rod may be further extended by hand to allow cylinder to contact the bottom thrust angle clevis in leg assembly.
15. Align the bottom cylinder clevis with the bottom thrust tube clevis and carefully drive the clevis pin through. Extreme care must be taken to prevent damage to the clevis bushings. Install the set screw, (engaging the slot in the pin), and torque to 25 ft. lbs.
16. Align the top cylinder rod clevis with the top trunnion clevis and carefully drive the clevis pin through. Extreme care must be taken to prevent damage to the clevis bushings. Install the set screw, (engaging the slot in the pin), and torque to 25 ft. lbs.
17. Connect the cylinder hydraulic hose to the tee in the leg assembly using the recommended sealant. (See below)
18. Check all pins and other mechanical and hydraulic components to assure that the assembly is complete and in good working order.
19. Turn the electrical supply back on and press the "UP" button on the controller to raise the lift. **NOTE:** 15 to 30 seconds time may elapse to fill the empty cylinders before movement is noted. NEVER raise a lift to the full raised height, until the cylinders and hoses have been completely bled of air.
20. Remove and place the maintenance leg in its storage location, then press the "DOWN" button on the controller to cycle the lift to the fully lowered position. Hold the "DOWN" button 30 to 40 seconds to allow air in the cylinders to bleed back into the reservoir tank.

GENERAL MAINTENANCE

' PH ' CYLINDER REPACKING (Reference Figure 6)

21. Cycle the lift 10 to 15 times and repeat the bleeding operation by holding the "DOWN" button for 30 to 40 seconds.
22. Check the oil level in the reservoir with the lift in the fully lowered position. Add oil as necessary (see "Routine Maintenance" for oil recommendations).
23. Clean or replace the oil filler breather cap if it appears dirty.
24. Clean up any debris and or spilled oil from the area.

PIPE THREAD SEALANT

Loctite PST #567 pipe thread sealant or equivalent is recommended. **Do not use Teflon tape.** Tape fragments can cause malfunctioning of the hydraulic system.

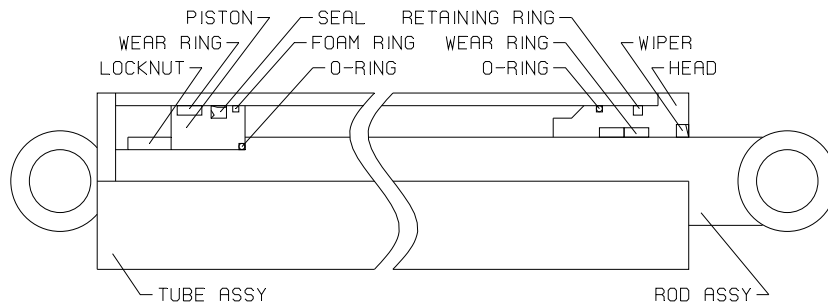

Figure 6: Hydraulic Cylinder

GENERAL MAINTENANCE

' TH ' CYLINDER REPACKING (Reference Figure 6)

CYLINDER REMOVAL AND REPACKING

1. Raise the lift to its full height and block securely. See "Lift Blocking Instructions".
2. Cut off the electricity to the power unit (lock out-tag out).
3. Disconnect the cylinder hose at the power unit end and insert it into the oil-fill hole of reservoir.
4. Loosen the bolt in the cylinder upper clevis.
5. Remove the cylinder pin from the upper clevis.
6. Lift the cylinder out of the leg assembly.
7. Push the piston rod into the cylinder to eject as much oil as possible into a container.
8. Insert a Spanner wrench and turn the upper bearing assembly clockwise until the tip of the retainer appears in the slot. Place a small screwdriver under the retainer and turn it until the retainer is completely removed.
9. Be sure the hose port is open to allow air into the cylinder. Pull the piston rod out to remove the upper bearing.
10. After all of the internal components have been removed, use a bright light to inspect the inner walls of the barrel. Use a cylinder hone to remove any apparent nicks or scratches. Clean and flush the barrel after honing.
11. Remove the piston head nut from the rod. The upper clevis and pin may be used to prevent rotation of the rod while loosening. Remove the old piston.
12. Inspect the groove for nicks or scratches that could affect the seal or barrel walls; remove as necessary.
13. Install the new piston, seals, and rod wiper.
14. Check the piston head nut for tightness and torque to 600-650 ft. lbs on 3" & 3 ½" bore cylinders or 850-950 ft. lbs. on 4" bore cylinders. The upper clevis and pin may be used to prevent the rotation of the rod while tightening.
15. Liberally lubricate the piston and seal with CLEAN grease or oil.

GENERAL MAINTENANCE

' TH ' CYLINDER REPACKING (Reference Figure 6)

CYLINDER REMOVAL AND REPACKING

16. Insert the piston into the barrel, taking care not to pinch or nick the new seal.
17. Slip the bearing assembly into place and align the retainer hole with the slot in the barrel.
18. Turn the bearing with the Spanner wrench until the retainer is reinserted completely.
19. Pull up the rod and reinstall the upper clevis pin and setscrew.
20. Reconnect the cylinder hose.
21. Check that the lag bolts are secure after checking all pins and other mechanical and hydraulic components.
22. Restore the oil level (see oil recommendations in the “Routine Maintenance” section).
23. Turn on the electrical power and press the “UP” button. It may take a few seconds to fill the empty cylinders. Raise the lift approximately one inch and remove the maintenance block.
24. Lower the lift completely and hold the “DOWN” button for 60 seconds to allow air in the cylinders to bleed back into the tank.
25. Raise the lift to 25 – 50% of its full travel, then lower fully holding the “DOWN” button for an additional 60 seconds. Repeat this step 8 – 10 times.
26. Check the oil level (see oil requirements).
27. Clean the oil fill breather cap.

PIPE THREAD SEALANT

Loctite PST #567 pipe thread sealant or equivalent is recommended. **Do not use Teflon tape.** Tape fragments can cause malfunctioning of the hydraulic system.

GENERAL MAINTENANCE



DANGER!

Do not attempt to remove the velocity fuse until the lift is securely supported with the maintenance locking devices and all hydraulic pressure has been removed from the lifting cylinders and hydraulic hoses. Failure to follow these instructions could result in personal injury or death!

VELOCITY FUSE REPLACEMENT

Never attempt to take a velocity fuse apart and repair it. These are precision devices that are factory assembled under exacting conditions. Velocity fuses should always be replaced.

1. The arrow on the exterior surface of the velocity fuse shows the direction of the restriction to the oil flow. The arrow should always point away from the cylinder.
2. **Do not use Teflon tape on the threaded connections.** Tape fragments can cause malfunctioning of the fuse. See Pipe Thread Sealant above.
3. Check all fitting connections for hydraulic leaks and tighten as necessary.

HOSE ORIENTATION

To prevent damage to the cylinder hose and possible failure of lift, it is necessary to establish a correct hose shape and pattern of movement as follows:

1. Raise the lift to its full height and block securely. See "Lift Blocking Instructions".
2. Install one end of the new hose to the cylinder elbow fitting.
3. Since the hose is fixed at both ends, it is possible to put a twist in the hose that will allow it to describe the same pattern each time the lift is operated. This twist will allow the hose to travel about half way between the cylinder on the right side and the inner leg on the right side.
4. Lower the lift carefully and check to see that the hose is free and clear of the cylinder and the inner leg assembly. If not, twist the hose in the direction necessary to clear it of any obstruction and then lock the swivel fitting securely.

GENERAL MAINTENANCE

STANDARD WALL MOUNT PUSHBUTTON SWITCH
(FRONT VIEW, COVER REMOVED)

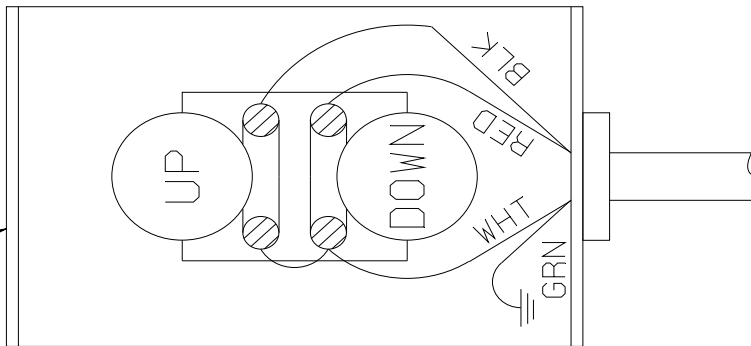

NOTES:

1. WARNING: ELECTRICAL HAZARD DISCONNECT POWER BEFORE WIRING THIS ACCESSORY.
2. COLOR CODING SHOWN CORRESPONDS TO EXISTING 16/4 SO CONTROL CORD ON LIFT.
3. USE APPROPRIATE WIRE, CONDUIT, ETC. TO SATISFY LOCAL CODES. (BY OTHERS.)

© 2000 COPYRIGHT RESERVED AUTOQUIP CORPORATION		BOX 1058 CUTHBERT, OK 73644 888-811-3876	1 REDRAWN IN CAD.	CWG	8/21/00
REFERENCE DWG.	DRAWING TITLE	JOB NAME:	NO.	REVISIONS	DATE
APPROXIMATE WEIGHT: (2T)	STD WALL MOUNT PUSHBUTTON WIRING DIAGRAM				
	AGU NO.				
	QTY. REQUIRED	REV.	DRAWING NUMBER:	SIZE	
	1 of 1	1	658-0734-9	A	

Figure 7: Pushbutton Wiring Diagram

GENERAL MAINTENANCE

351-0338-0

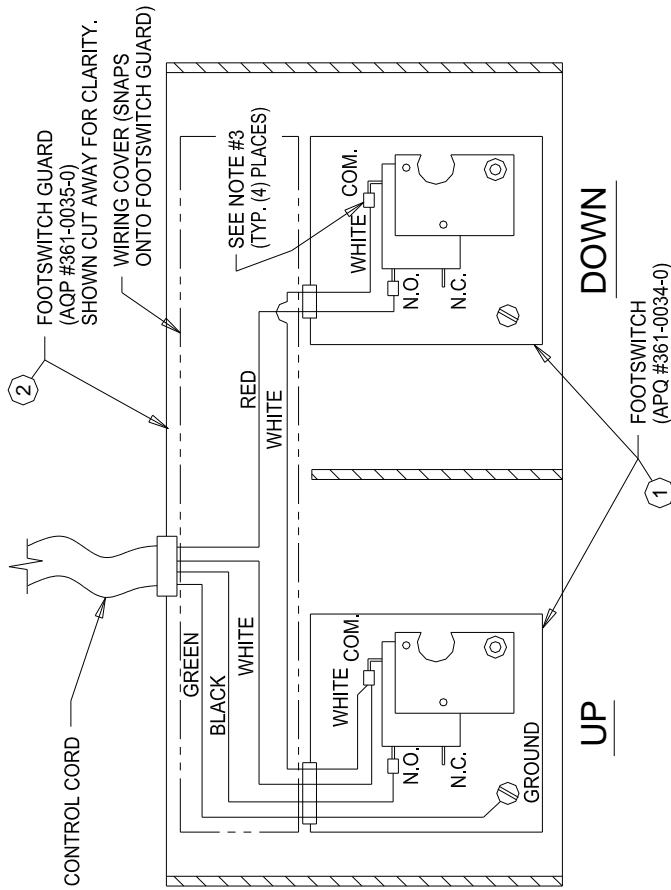

STANDARD FOOTSWITCH ASSEMBLY
(TOP VIEW WITH TOP COVERS OF FOOTSWITCHES REMOVED)

NOTES:

- WARNING: ELECTRICAL HAZARD.** DISCONNECT POWER BEFORE WIRING THIS ACCESSORY.
- COLOR CODING SHOWN CORRESPONDS TO EXISTING 16/4 SO CONTROL CORD ON LIFT.
- USE 3/16" WIRE TABS FOR WIRING FOOTSWITCH.
- EXCHANGE BLACK AND RED WIRES IF DESIRED TO SWITCH "UP" AND "DOWN" FUNCTIONS.
- USE APPROPRIATE WIRE, CONDUIT, ETC. TO SATISFY LOCAL CODES (BY OTHERS).
- INSTALL FOOTSWITCH GUARD PER MANUFACTURER'S INSTRUCTIONS.
- INSTALLER TO APPLY "UP" AND "DOWN" LABELS TO TOP OF COVER AS REQUIRED.
- ELECTRICAL RATING WITHOUT CORD 15 AMP, 115/230VAC
- FOOT GUARD PAINTED YELLOW

©2008 ALL RIGHTS RESERVED AUTOQUIP CORPORATION This drawing is the sole property of Autoquip Corp. and cannot be used for design and construction without permission of Autoquip Corp.	REV: DESCRIPTION JOB NAME:	BY:	DATE:
	ORDER NO:		
REFERENCE DRAWING:	DRAWING TITLE: FOOTSWITCH - GUARDED		
APPROXIMATE WEIGHT:	QTY REQD: 1 OF 2	REV: 2	DRAWING NUMBER: 351-0338-0
DRAWN BY: DWL	DATE: 06/30/93	PAGE:	SIZE: A

Figure 8A: Footswitch Wiring Diagram

GENERAL MAINTENANCE

351-0338-0

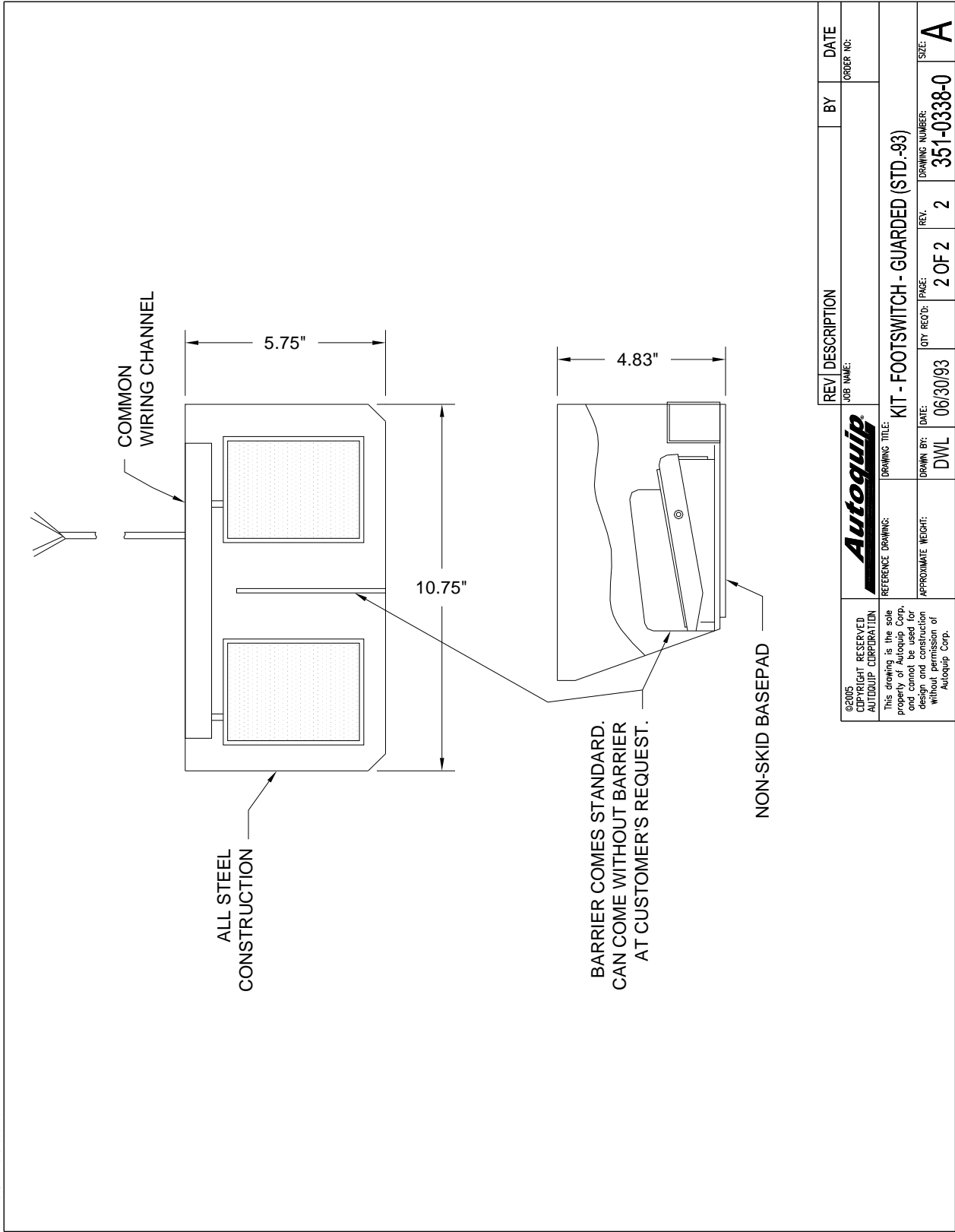

<small>©2005 COPYRIGHT RESERVED AUTOQUIP CORPORATION</small> <small>This drawing is the sole property of Autoquip Corp. and cannot be used for design and construction without permission of Autoquip Corp.</small>	<b style="font-size: 1.2em;">Autoquip <small>REFERENCE DRAWING:</small>	<small>REV DESCRIPTION</small> <small>JOB NAME:</small>	<small>DATE</small> <small>ORDER NO:</small>
<small>DRAWING TITLE:</small> KIT - FOOTSWITCH - GUARDED (STD.-93)	<small>APPROXIMATE WEIGHT:</small> DWL	<small>QTY REQ'D:</small> 2 OF 2	<small>REV.</small> 2
<small>DRAWN BY:</small> DWL	<small>DATE:</small> 06/30/93	<small>PAGE:</small> 2 OF 2	<small>DRAWING NUMBER:</small> 351-0338-0
			<small>SIZE:</small> A

Figure 8B: Footswitch & Guard Diagram

GENERAL MAINTENANCE

65700810

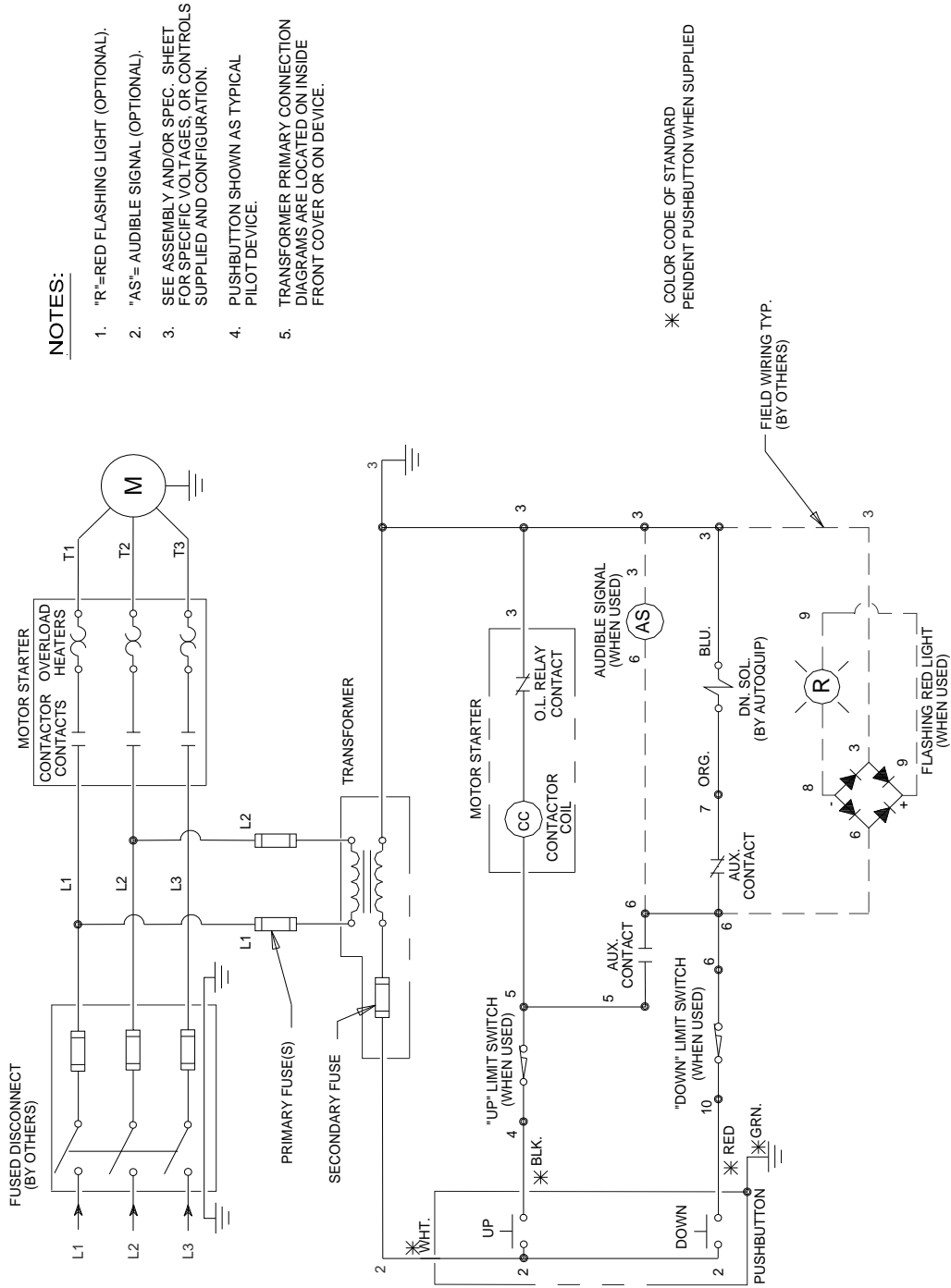

NOTES:

1. "R"=RED FLASHING LIGHT (OPTIONAL).
2. "AS"= AUDIBLE SIGNAL (OPTIONAL).
3. SEE ASSEMBLY AND/OR SPEC. SHEET FOR SPECIFIC VOLTAGES, OR CONTROLS SUPPLIED AND CONFIGURATION.
4. PUSHBUTTON SHOWN AS TYPICAL PILOT DEVICE.
5. TRANSFORMER PRIMARY CONNECTION DIAGRAMS ARE LOCATED ON INSIDE FRONT COVER OR ON DEVICE.

* COLOR CODE OF STANDARD PENDENT PUSHBUTTON WHEN SUPPLIED

FIELD WIRING TYP. (BY OTHERS)

<p>2010 COPYRIGHT RESERVED AUTOQUIP CORPORATION</p> <p>REFERENCE DRAWING: This drawing is the sole property of Autoquip Corp. and cannot be used for design and construction without permission of Autoquip Corp.</p>	<p>JOB NAME: _____</p>		<p>ORDER NO: _____</p>	
	<p>Autoquip</p>			
<p>APPROXIMATE WEIGHT: _____</p>	<p>DRAWN BY: ML</p>	<p>DATE: 3/6/02</p>	<p>QTY REQ'D: 1</p>	<p>REV: 1</p>
<p>DRAWING TITLE: ELEC SCH FOR STD, UTIL & CONTR PU W/UP&DWN LMTSW</p>	<p>DRAWING NUMBER: 65700810</p>	<p>PAGE: 1 OF 1</p>	<p>REV: 1</p>	<p>SIZE: A</p>

Figure 9A: Electrical Schematic – 5HP/ 3 Ph Contractor or Vertical Power Unit

GENERAL MAINTENANCE

657-5004-0

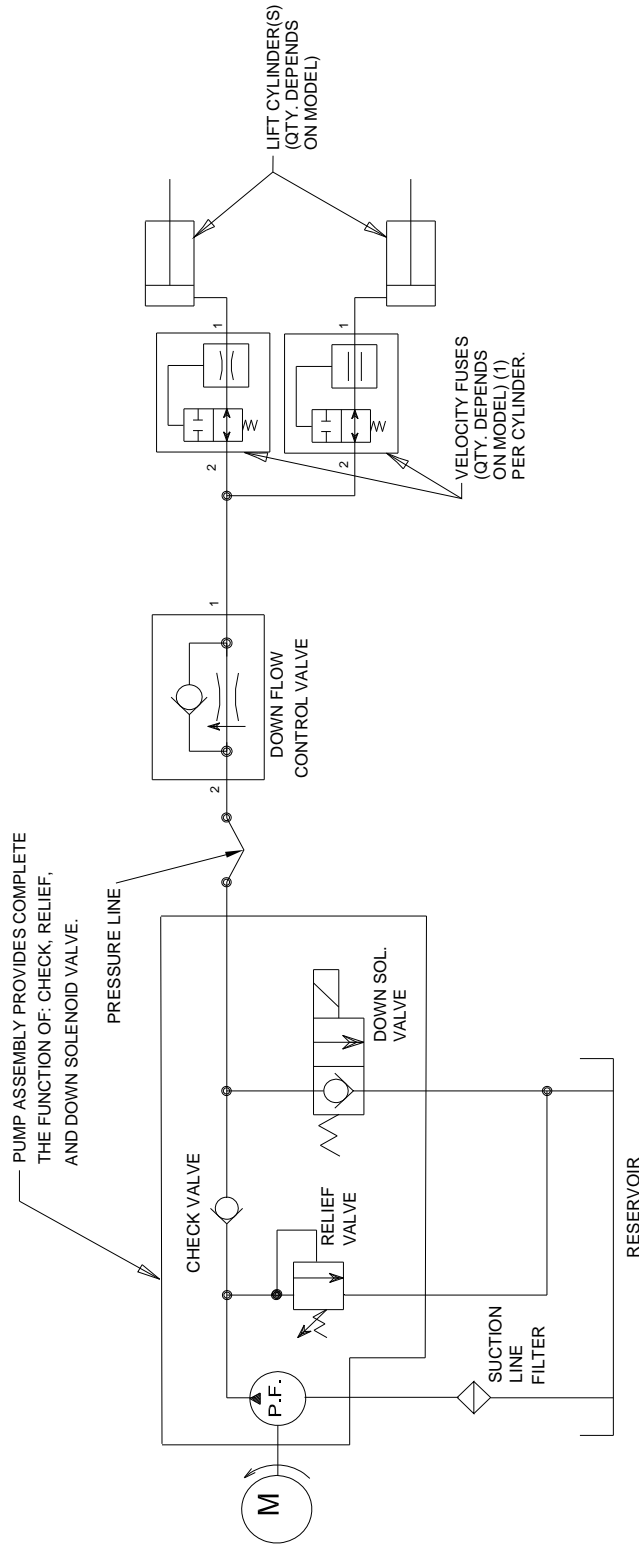

HYDRAULIC SCHEMATIC

©2005 COPYRIGHT RESERVED AUTOQUIP CORPORATION This drawing is the sole property of Autoquip Corp. and cannot be used for design and construction without permission of Autoquip Corp.	REFERENCE DRAWING: 658-0732-3	DRAWING TITLE: HYD SCH FOR SM & PLT-C	REV DESCRIPTION JOB NAME:	BY	DATE
	APPROXIMATE WEIGHT: N/A	DRAWN BY: DWL	DATE: 9/11/95	QTY. REQ'D: 1 OF 1	REV: 2
			DRAWING NUMBER: 657-5004-0		SIZE: A

Figure 9B: Hydraulic Schematic – Contractor Power Unit

GENERAL MAINTENANCE

657-5000-1

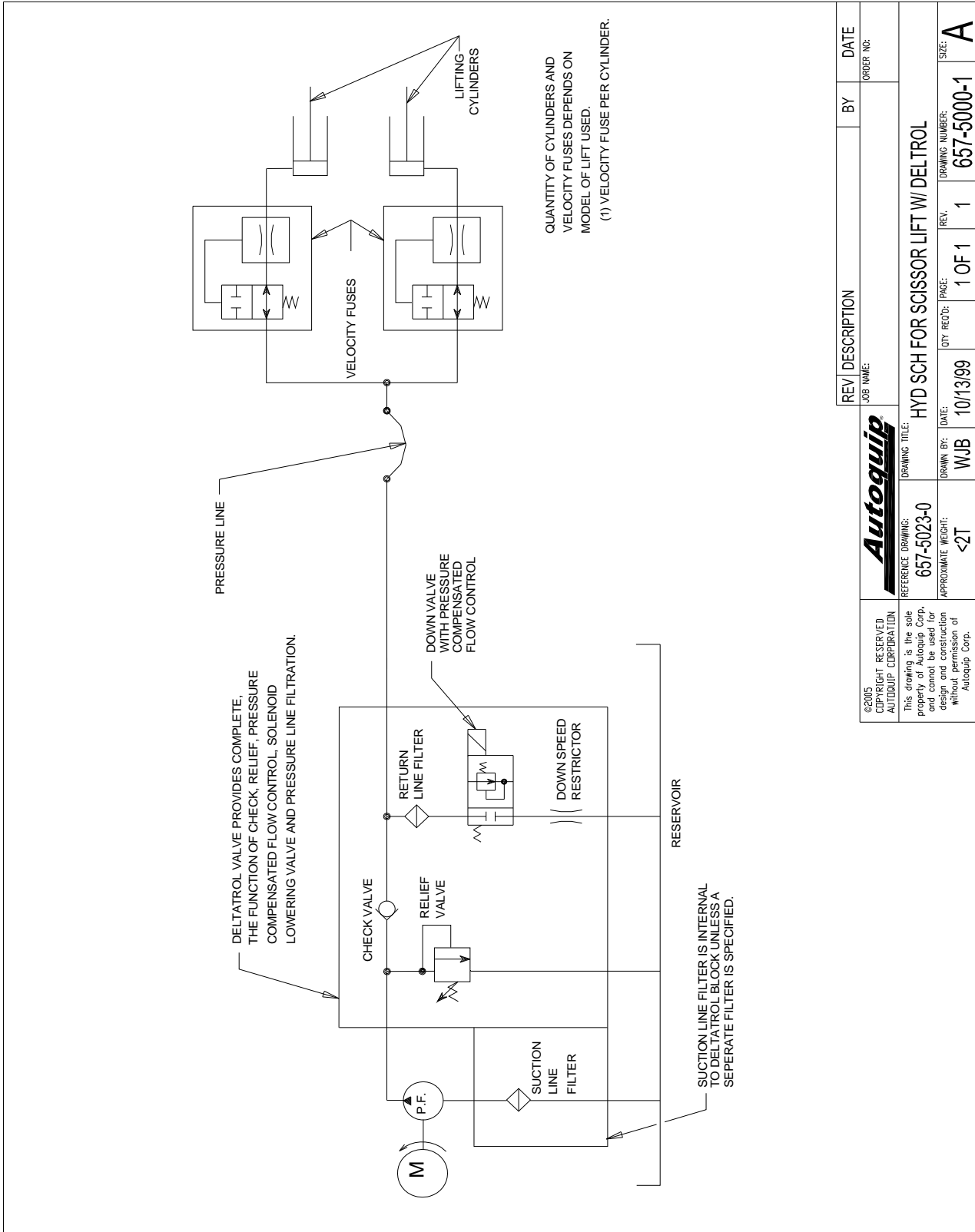

Figure 9C: Hydraulic Schematic – Vertical Power Unit

REV DESCRIPTION		BY	DATE
JOB NAME:			ORDER NO:
Autoquip			
REFERENCE DRAWING:	DRAWING TITLE:		
657-5023-0	HYD SCH FOR SCISSOR LIFT W/ DELTROL		
APPROXIMATE WEIGHT:	QTY REQD:	PAGE:	REV.
<2T	1	1 OF 1	1
DRAWN BY:	DATE:	DRAWING NUMBER:	SIZE:
WJB	10/13/99	657-5000-1	A

GENERAL MAINTENANCE

60401106

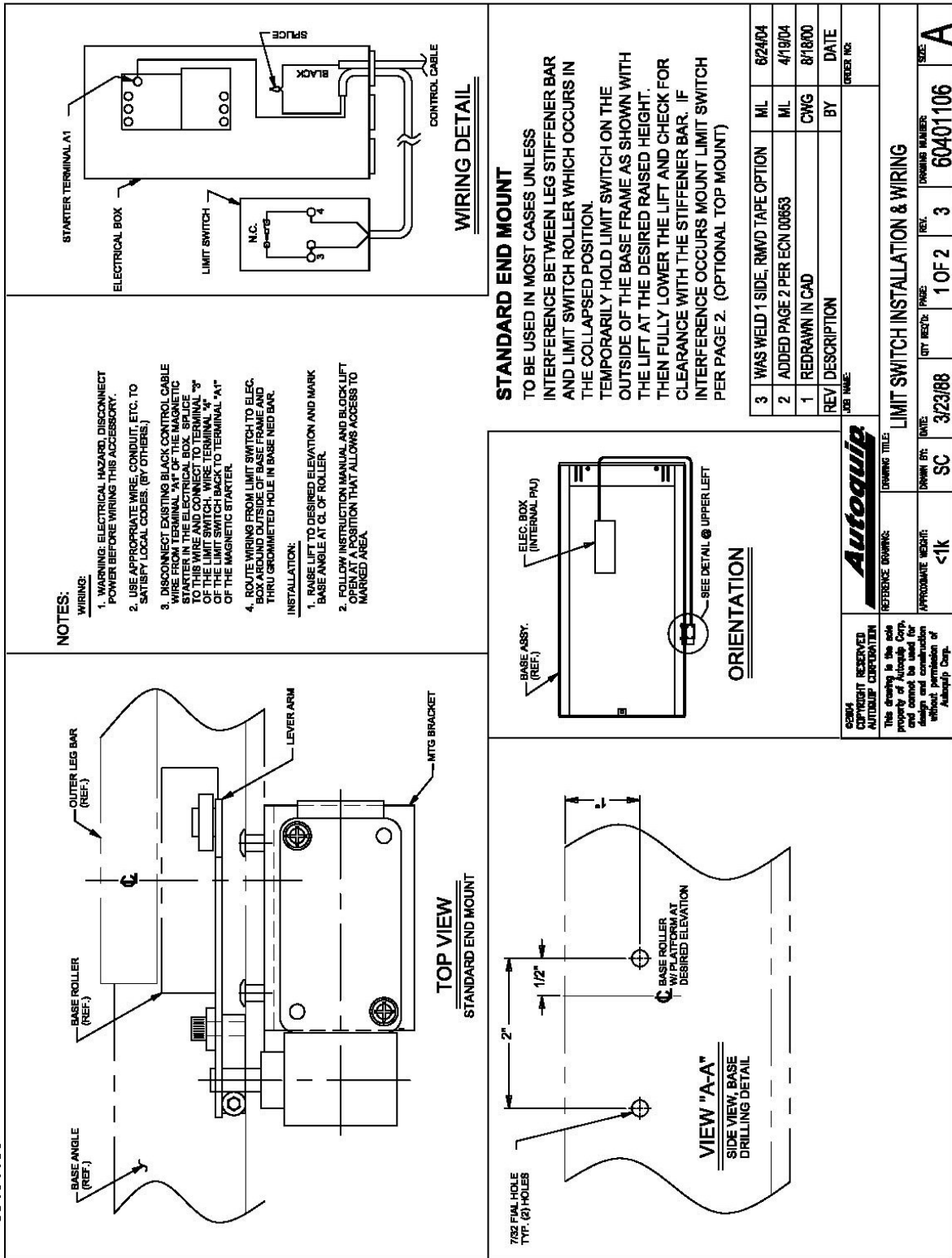

Figure 10: 'UP' Limit Switch Installation and Wiring

REPLACEMENT PARTS LIST

HYDRAULIC PARTS LIST: -- (Reference Figure 11)

ITI No.	QTY	Description	Part No.
		INSPECT CYLINDER FOR ACUTAL PART NUMBER (PART NUMBER IS STAMPED ON CYLINDER)	
1	2	Cylinder, 3" bore x 16-1/2" stroke (all 60" travel models)	42600870 PH
1	2	Cylinder, 3" bore x 20" stroke (all 72" travel models)	42600860 PH
1	2	Cylinder, 3" bore x 26" stroke (all 84" travel models)	42600850 PH
1	2	Cylinder, 3" bore x 30" stroke (all 96" travel models)	42600840 PH
		Seal Kit - Single Cylinder Kit (for all 3" Bore PH cylinders)	45503460PH
		(Cylinders without the PH in the part number are TH cylinders <u>Or</u> <u>Special order cylinders</u>). CONTACT AUTOQUIP FOR REPLACEMENT	
		Seal Kit - Single Cylinder Kit (for all 3" Bore TH cylinders)	45503270
2	2	Hydraulic elbow, 1/4" MP – 1/4" MP	26100370
3	2	Velocity Fuse, 3.5 GPM (1/4" FNPT)	41800514
3	2	Velocity Fuse, 4.5 GPM (1/4" FNPT)	41800558
3	2	Velocity Fuse, 5.0 GPM (3/8" FNPT)	41800930
		INSPECT HOSE FOR PART NUMBER (PART NUMBER IS STAMPED ON HOSE)	
4	1	Hydraulic Hose, 1/4" (1/4"MNPT x 3/8" MNPTS) x 10" L.	46000480
4	1	Hydraulic Hose, 1/4" (1/4"MNPT x 1/4" MNPTS) x 12" L.	46000030
4	1	Hydraulic Hose, 1/4" (1/4"MNPT x 1/4" MNPT) x 24" L.	46000071
4	1	Hydraulic Hose, 1/4" (1/4"MNPT x 3/8"MNPTS) x 25" L.	46000490
4	1	Hydraulic Hose, 1/4" (1/4"MNPT x 1/4" MNPT) x 36" L.	46000097
4	1	Hydraulic Hose, 3/8" (3/8"MNPT x 3/8"MNPTS) x 12" L.	46000012
4	1	Hydraulic Hose, 3/8" (3/8"MNPT x 3/8"MNPTS) x 24" L.	46100038
4	1	Hydraulic Hose, 3/8" (3/8"MNPT x 3/8"MNPTS) x 36" L.	46000053
4	1	Hydraulic Hose, 3/8" (3/8"MNPT x 3/8"MNPTS) x 48" L.	46000061
5	1	Hose Nipple, 3/8" MNPT x 1/4" MNPT)	26050096
6	1	Hydraulic Tee, 3/8" FNPT, (3 way)	26150102
6	1	Hydraulic Tee, 1/2" FNPT, (3 way)	26150151
7	1	Hydraulic Hose, 3/8" (3/8"MNPT x 3/8"MNPTS) x 72" L.	46100087
7	1	Hydraulic Hose, 1/2" (1/2"MNPT x 1/2" MNPTS) x 48" L.	46200093
7	1	Hydraulic Hose, 1/2" (1/2"MNPT x 1/2" MNPTS) x 72" L.	46200127
6	1	Hydraulic Tee, 3/8" FNPT, (3 way)	26150102
6	1	Hydraulic Tee, 1/2" FNPT, (3 way)	26150151
8	1	Bushing Hex, 1/2"MPNT x 3/8"FNPT	26300251
9	1	Down Flow Control Valve; 3.0 GPM (Down Flow Control Valve May be in Hose Layout or on Remote Power Unit)	41502840
10	1	Hose Nipple, 3/8" MNPT x 1/4" MNPT) (When Used)	26050096
10	1	Hose Nipple, 1/2" MNPT x 3/8" MNPT) (When Used)	26050153

REPLACEMENT PARTS LIST

35107890 1 OF 1

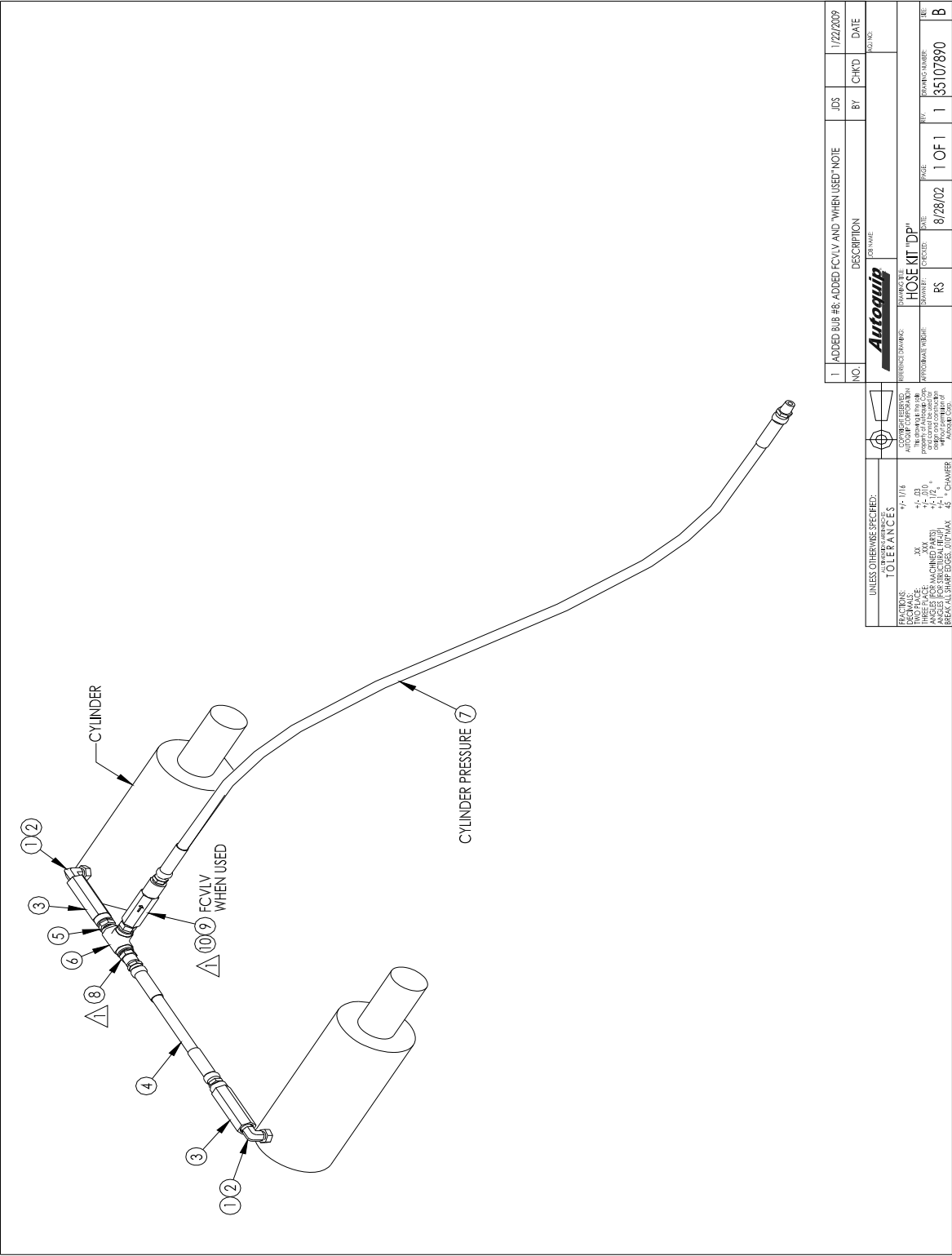

NO.	DESCRIPTION	BY	CHKD	DATE			
1	ADDED BUB #6; ADDED FCV/VV AND "WHEN USED" NOTE	JDS		1/22/2009			
Autoquip							
<table border="1" style="width: 100%; border-collapse: collapse;"> <tr> <td style="width: 30%;"> UNLESS OTHERWISE SPECIFIED: TOLERANCES DECIMALS: .125, .250, .500 FRACTIONS: 1/32, 1/16, 1/8, 3/16, 1/4, 3/8, 1/2, 5/8, 3/4, 7/8 ANGLES (FOR MACHINED PARTS): 45°, 60°, 90°, 120°, 150° BREAK ALL SHARP EDGES: .010" MAX. BREAK ALL SHARP CORNERS: .010" MAX. CHAMFER </td> <td style="width: 30%;"> TECHNICAL DRAWING: HOSE KIT "DP" DRAWN BY: RS CHECKED BY: [blank] DATE: 8/28/02 </td> <td style="width: 40%;"> DRAWING NUMBER: 35107890 PAGE: 1 OF 1 </td> </tr> </table>					UNLESS OTHERWISE SPECIFIED: TOLERANCES DECIMALS: .125, .250, .500 FRACTIONS: 1/32, 1/16, 1/8, 3/16, 1/4, 3/8, 1/2, 5/8, 3/4, 7/8 ANGLES (FOR MACHINED PARTS): 45°, 60°, 90°, 120°, 150° BREAK ALL SHARP EDGES: .010" MAX. BREAK ALL SHARP CORNERS: .010" MAX. CHAMFER	TECHNICAL DRAWING: HOSE KIT "DP" DRAWN BY: RS CHECKED BY: [blank] DATE: 8/28/02	DRAWING NUMBER: 35107890 PAGE: 1 OF 1
UNLESS OTHERWISE SPECIFIED: TOLERANCES DECIMALS: .125, .250, .500 FRACTIONS: 1/32, 1/16, 1/8, 3/16, 1/4, 3/8, 1/2, 5/8, 3/4, 7/8 ANGLES (FOR MACHINED PARTS): 45°, 60°, 90°, 120°, 150° BREAK ALL SHARP EDGES: .010" MAX. BREAK ALL SHARP CORNERS: .010" MAX. CHAMFER	TECHNICAL DRAWING: HOSE KIT "DP" DRAWN BY: RS CHECKED BY: [blank] DATE: 8/28/02	DRAWING NUMBER: 35107890 PAGE: 1 OF 1					

Figure 11: Cylinder & Hose Diagram

REPLACEMENT PARTS LIST

60DP90 TO 96DP90 PARTS LIST - CONTACT AUTOQUIP SERVICE DEPT. FOR ADDITIONAL MODEL LIFTS -- (Reference Figure 12)

ITEM	PART #	DESCRIPTION
1	24012502	Washer, 1/16" X 1.502 X 2-1/8"
2	45400249	Retainer Ring, 1-1/2" Heavy Duty
3	20023925	DU Bushing, 24DU16, 1.500 X 1.000 L
4	52501491	Roller Pin, 1.500 X 2.125 L (1) Ring Groove
5	52601640	Roller w/ Bushing, 1" W X 3" OD X 1-1/2" ID
6	45400546	Retainer Ring, 1-3/4" Heavy Duty
7	24026008	Washer, 0.120 X 1.781 ID X 2-3/4" OD
8	52505130	Leg Pivot Pin, 1.750 X 3.563, (1) Ring Groove, Heavy Duty
9	20024667	Bushing, 28DU24, 1.750 ID X 1.500 L
10	52504032	Clevis Pin, 1.500 X 2.063 L, (2) Ring Grooves
11	52505470	Bottom Cylinder Pin, w/ Non-Rotator
12	52505480	Top Cylinder Pin w/ Non-Rotator, 1-1/8" X 6-5/8" L
NA		Platform Assembly – Contact Autoquip Service Dept.
NA		Internal Power Unit – Contractor Power Unit
NA		Leg Assembly – Contact Autoquip Service Dept.
NA		Cylinder or Cylinder Seal Kit – See Hydraulic Parts List
NA		Base Assembly – Contact Autoquip Service Dept.

REPLACEMENT PARTS LIST

83000050 1 OF 1

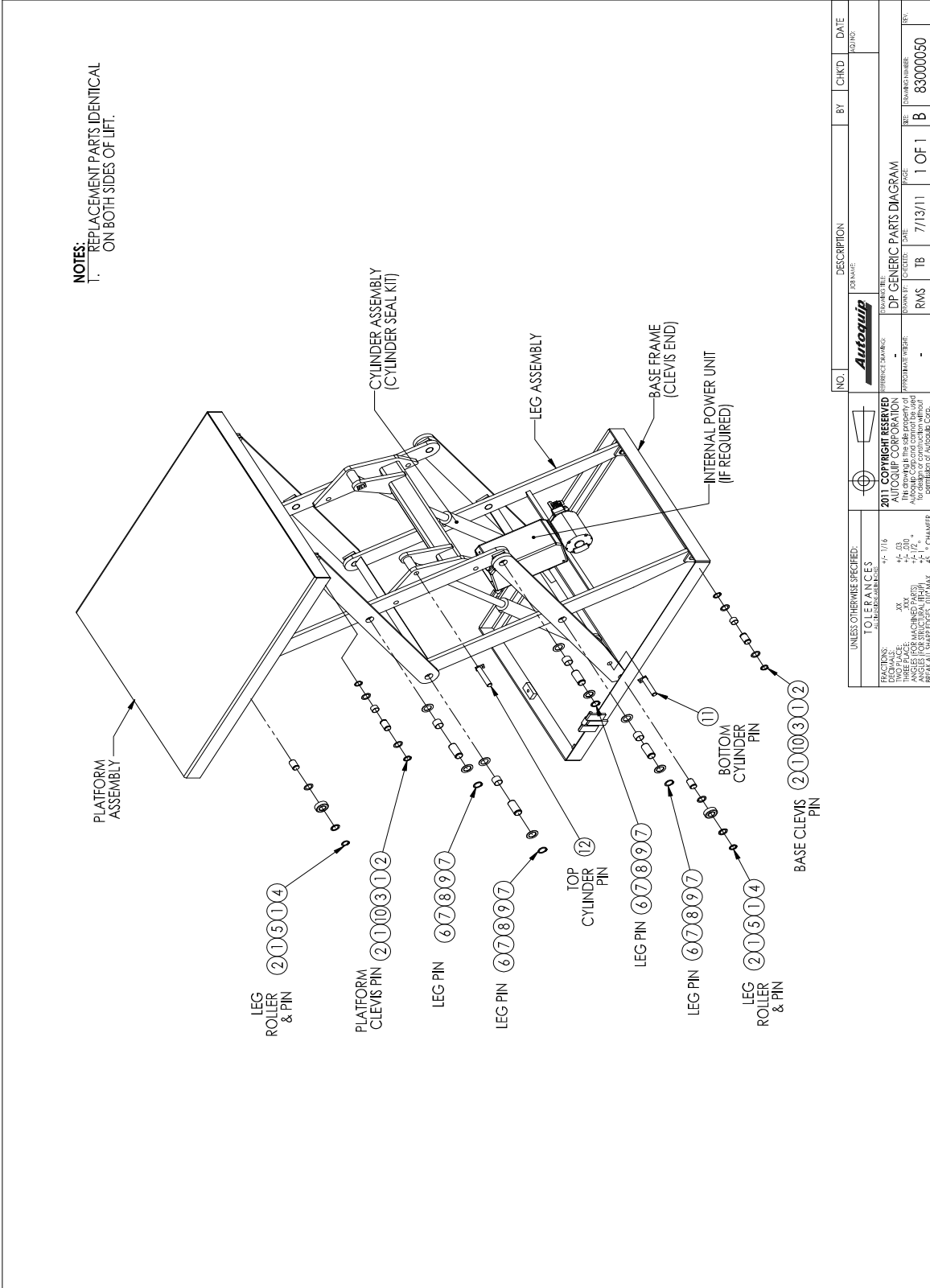

Figure 12: Replacement Parts Diag

REPLACEMENT PARTS LIST

Contractor Power Unit

CONTRACTOR POWER UNIT -- (Reference Figure 13A & 13B)

PART #	DESCRIPTION
65750040	HYDRAULIC SCHEMATIC
6430633X	Contractor P.U. Assembly without Sol. Coil (select coil below)
64201020	Polyethylene Reservoir (9" x 9" x 18")
47701640	Filler Breather Cap
30600613	5 HP Contractor Motor; 208-230-460V / 60CY / 3 PH: Tang Shaft, C-Face, Foot Mt,
40200655	Pump, 2.8 GPM, Tang Shaft; without Sol. Coil (select coil below)
41502840	Down Flow Control Valve; 3.0 GPM
41050139	Suction Strainer (Reservoir)
32701290	Solenoid Coil 24Volt AC (Down Valve)
32701300	Solenoid Coil 115 Volt AC (Down Valve)
	12
35194090	Up/Down Pushbutton Kit (Wall Mount or Handheld PB) with 20 Ft. Straight Cord
35150140	Controller Assembly : 208 – 230 Volt /60Hz/3PH ; 24Volt Control Voltage
35150145	Controller Assembly : 208 – 230 Volt /60Hz/3PH ; 115Volt Control Voltage
35150150	Controller Assembly : 460 Volt /60Hz/3PH ; 24Volt Control Voltage
35150155	Controller Assembly : 460 Volt /60Hz/3PH ; 115Volt Control Voltage

REPLACEMENT PARTS LIST

Contractor Power Unit

826-0084-0

NOTES:

1. APPROXIMATE OVERALL DIMENSIONS OF POWER UNIT - 24"x17"x11" HIGH.
2. CONTROLS PER QUOTATION.

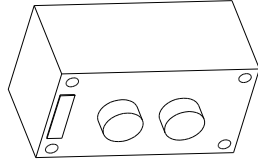
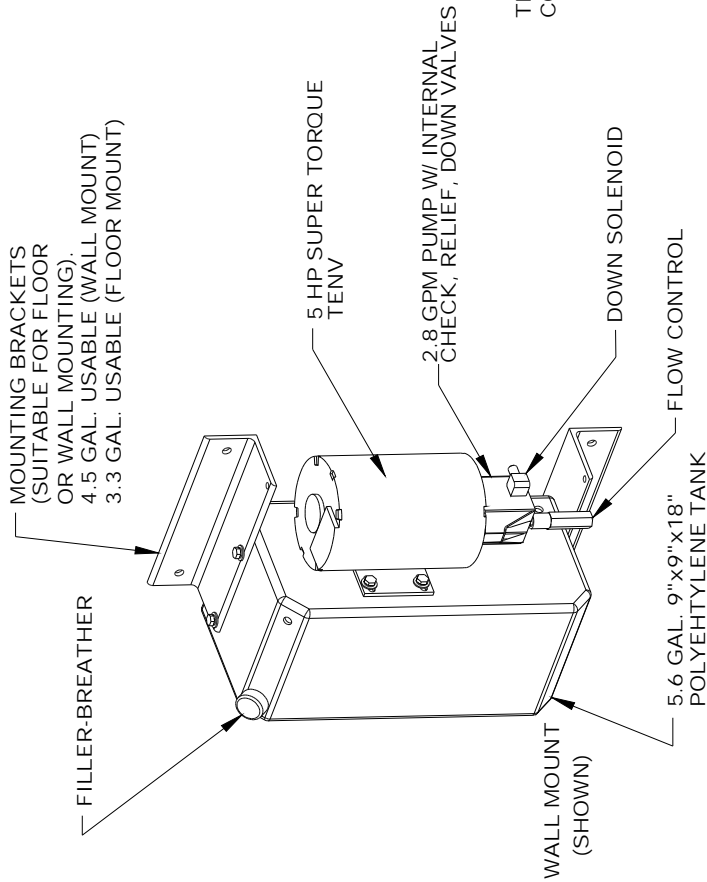

PUSHBUTTON
HAND HELD
OR
WALL MOUNTED.
(SHIP LOOSE.)

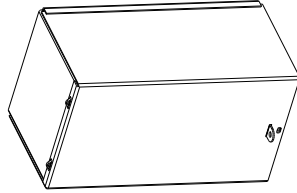

CONTROL PANEL
TRANSFORMER, STARTER, &
CONTACTOR PRE-WIRED TO
TERMINAL STRIP.
(SHIP LOOSE.)



POWER UNIT - CONTRACTOR PLT

PROPOSAL DRAWING
QUOTE NO.

826-0084-0 REV 3, 5-24-02

AUTOQUIP CORP.
1058 W. INDUSTRIAL AVE.
GUTHRIE, OK 73044-1058
888-811-9876 WWW.AUTOQUIP.COM

© COPYRIGHT RESERVED
AUTOQUIP CORPORATION
2002

Figure 13A: Contractor Power Unit Parts Detail

REPLACEMENT PARTS LIST

Contractor Power Unit

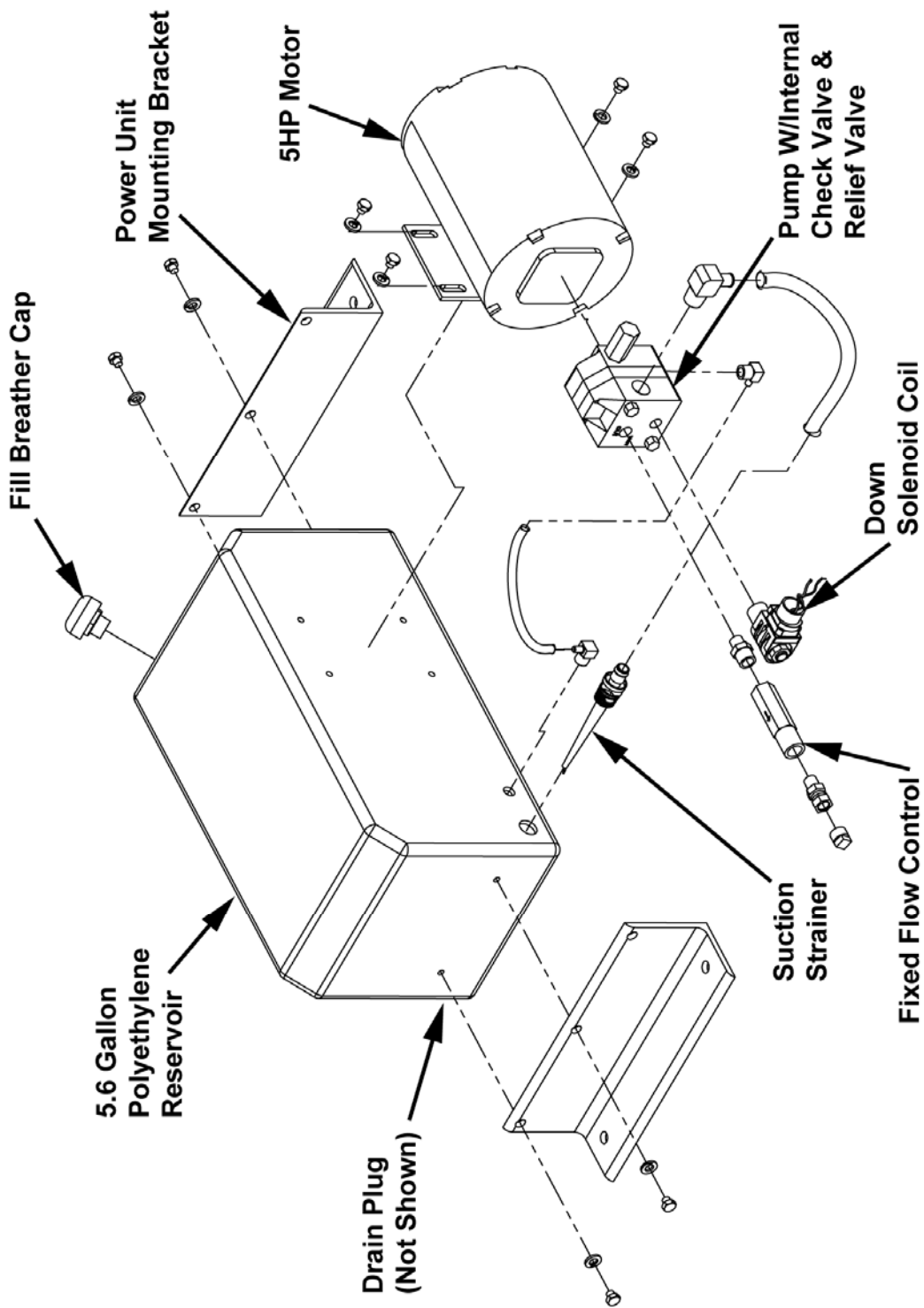

Figure 13B: Contractor Power Unit Parts Detail
 (Approximate Size: 18" x 20" x 12"H)

REPLACEMENT PARTS LIST

5HP Vertical Power Unit

VERTICAL POWER UNIT -- (Reference Figure 14A to 14C)

ITEM	PART #	DESCRIPTION
----	65750001	HYDRAULIC SCHEMATIC
1	64000813	16X16X10 Reservoir
2	47700208	Filler Breather Cap for Reservoir
3	47302905	Motor & Pump Mounting Bracket
4	30600449	5 Horsepower Motor; 3450 RPM, C-Face, Foot Mt. (Not Continuous Duty Motor)
6	40300162	4.5 G.P.M. Pump; Straight Shaft
7	20000253	Coupling; Spider
8	20000238	Motor Coupling 1-1/8" Bore (Motor)
9	20001442	Pump Coupling 7/16" Bore (Pump)
10	47700075	Suction Strainer (Reservoir)
11	41001010	Deltatrol Valve Assembly with out Coil
12	32701380	Solenoid Coil 24 Volt AC (Deltatrol Valve)
12	32701370	Solenoid Coil 115 Volt AC (Deltatrol Valve)
		*** Check for 24Volt or 115Volt Control Voltage ***
14	41050048	Gasket (Deltatrol)
15	45975497	Gasket (Motor / Reservoir)
16	46100900	Hose, 3/8"x 14", w/ 1/4" npt one end
----	41050880	Deltatrol Kit
17	25001310	Return Pipe Assembly; 6" long
----	64251230	Controller Mounting Plate (for Pre-wired Power Units)
----	35150140	Controller Assembly : 208 – 230 Volt /60Hz/3PH ; 24Volt Control Voltage
----	35150145	Controller Assembly : 208 – 230 Volt /60Hz/3PH ; 115Volt Control Voltage
----	35150150	Controller Assembly: 460 Volt /60Hz/3PH ; 24Volt Control Voltage
----	35150155	Controller Assembly: 460 Volt /60Hz/3PH ; 115Volt Control Voltage
----	35194090	Up/Down Pushbutton Kit (Wall Mount or Handheld PB) with 20 Ft. Straight Cord

82600270

POWER UNIT - 16" X 22" X 29" HIGH.
APPROXIMATE OVERALL DIMENSIONS OF
CONTROLS PER QUOTATION $\frac{2}{3}$

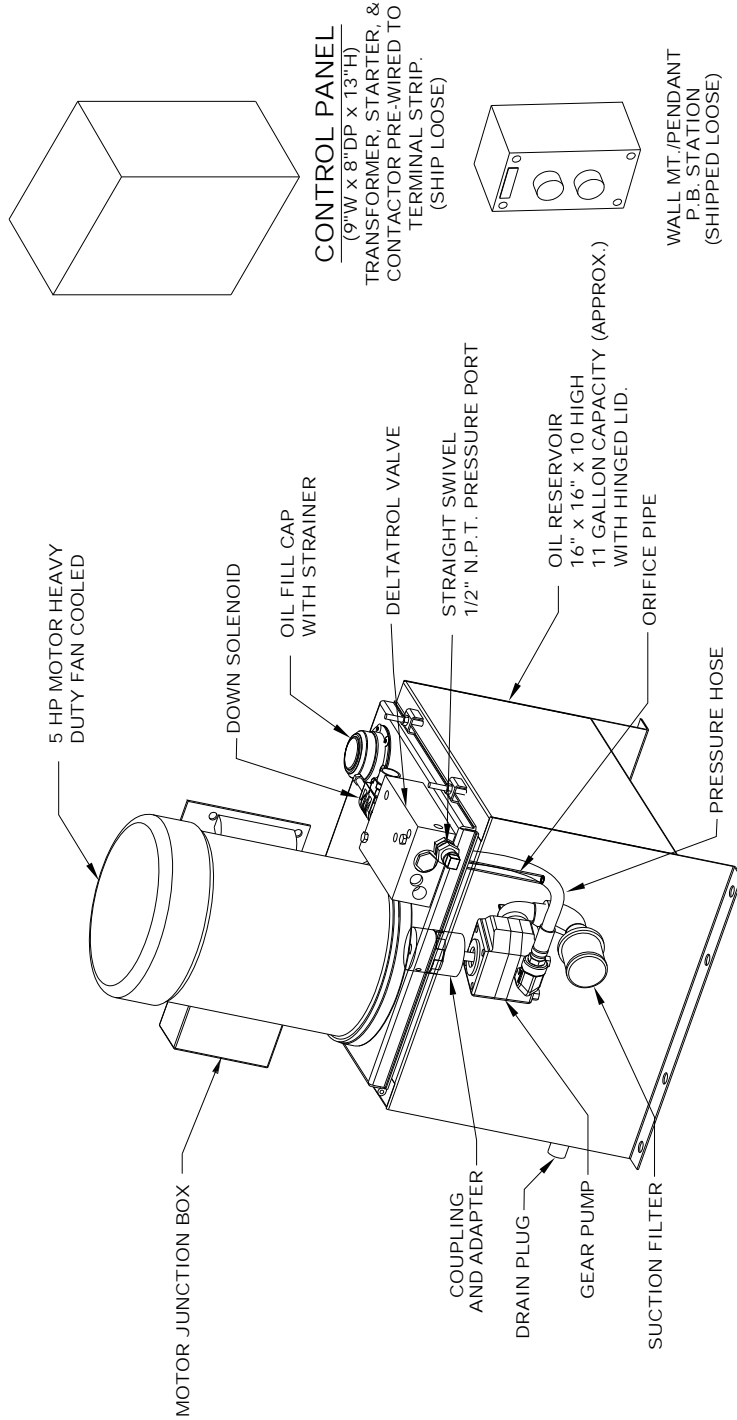

POWER UNIT-5HP VERTICAL STANDARD



AUTOQUIP CORP.
1058 W. INDUSTRIAL AVE.
GUTHRIE, OK 73044-1058
888-811-9876 WWW.AUTOQUIP.COM

(NOT TO SCALE)
PROPOSAL DRAWING
QUOTE NO.

82600270 REV 2, 10/11/05

© COPYRIGHT RESERVED
AUTOQUIP CORPORATION
2005

Figure 14A: Vertical Power Unit Parts Detail

REPLACEMENT PARTS LIST

5HP Vertical Power Unit

6430157GEN 1 OF 2

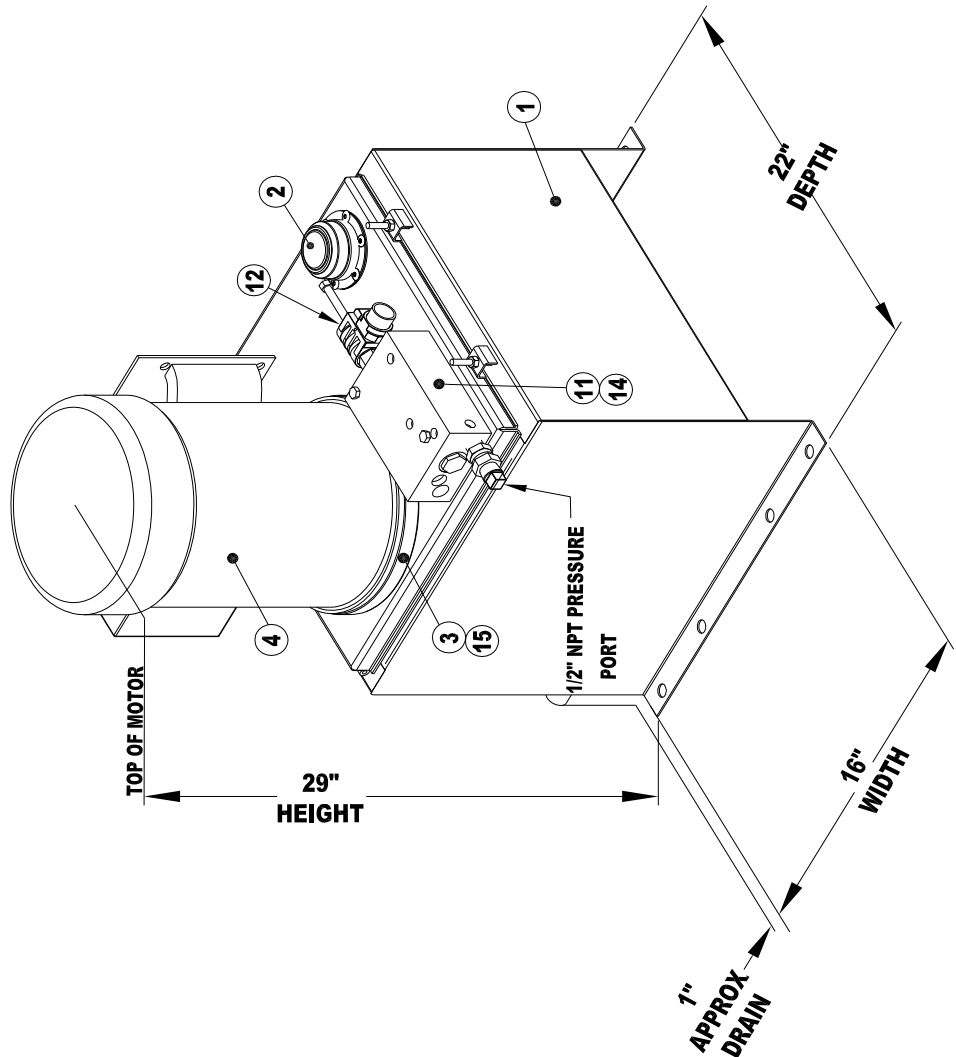

<small>Autogrip</small> <small>Autogrip Controls</small> <small>Autogrip Controls, Inc.</small> <small>1000 W. 10th St.</small> <small>St. Paul, MN 55108</small> <small>Phone: 612-761-1111</small> <small>Fax: 612-761-1112</small> <small>www.autogrip.com</small>	REVISED	BY	DATE
	1 OF 2	18/00	6430157GEN C

Figure 14B: Vertical Power Unit Parts Detail

REPLACEMENT PARTS LIST

5HP Vertical Power Unit

6430157GEN 2 OF 2

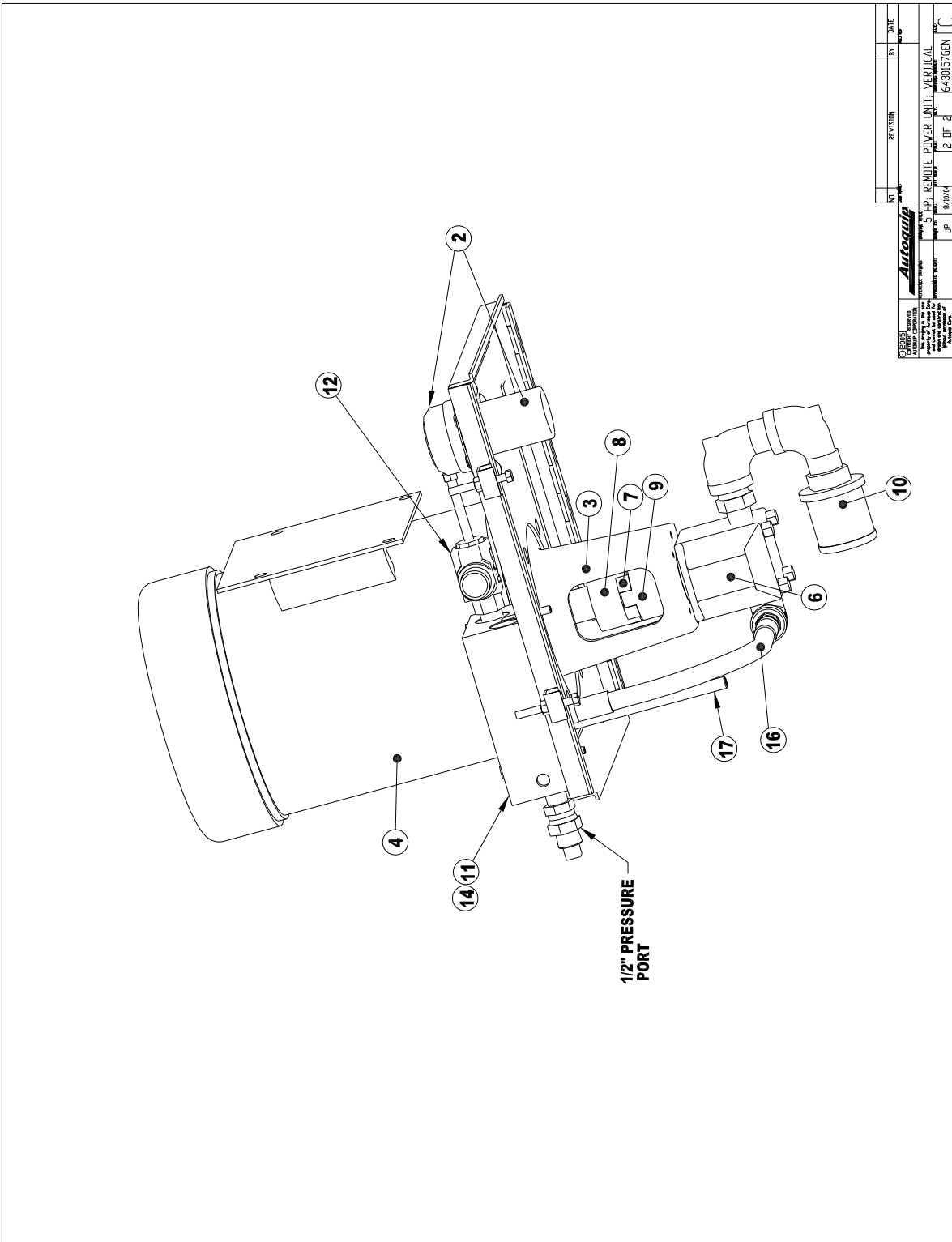

REV	REVISION	BY	DATE
1			

Autoquip
 AUTOMATIC SERVICE
 5 HP. REMOTE POWER UNIT, VERTICAL
 8/10/04
 2 OF 2
 6430157GEN C

Figure 14C: Vertical Power Unit Parts Detail

TROUBLESHOOTING ANALYSIS

DANGER!



To avoid personal injury, NEVER go under the lift platform until the load is removed and the scissors mechanism is securely blocked in the open position. See "Lift Blocking Instructions" section.

PROBLEM	POSSIBLE CAUSE AND SOLUTION
<p>Lift will not Raise.</p>	<ul style="list-style-type: none"> • The motor rotation for a 3-phase motor may be reversed. Reverse only two motor electrical leads. • Check for a line or hose leak. • Check for oil shortage in the reservoir. Add oil as necessary (See Oil Requirements in the "Routine Maintenance" section.) • The load may exceed the rating. (See the "Specifications" section.) Remove the excess load. • The suction screen may be clogged, starving the pump. Remove and clean the screen. Drain and replace the oil. • The suction line may be leaking air due to a loose fitting. Tighten as needed. • The breather holes in the reservoir fill plug may be clogged. Remove and clean. • The voltage at the motor terminals may be too low to run the pump with the existing load. Check by measuring the voltage at the motor terminals, or as near as possible, <u>while the pump is running under load</u>. Reading the source voltage or pump-idling voltage is meaningless. Inadequate or incorrect wiring can starve the motor when the source voltage is ample. Correct as necessary. • The "Down" valve may be energized by faulty wiring. Check the solenoid wiring. • The "Down" valve stem may be bent causing the valve to stick open. Replace the down solenoid valve. • The motor may be single phasing. Check wiring, fuses, etc. • The pump may be seized if motor is humming or blowing fuses on overload protection devices. Remove the pump. The pump should be able to be rotated by hand. Check for cracks in the housing.

TROUBLESHOOTING ANALYSIS

PROBLEM	POSSIBLE CAUSE AND SOLUTION
Lift will not Raise – Continued.	<ul style="list-style-type: none">• The manual lowering device may be engaged.• AIR POWER UNIT: Air hose connections may be leaking air or hoses maybe crimped. Check for air leaks and hose crimping and resolve these issues. <p>There may be insufficient air pressure or air flow at the air motor. Air requirements at the air motor are: 90 PSI & 110 CFM). Check the air supply at the air motor and resolve air supply issues.</p>

TROUBLESHOOTING ANALYSIS

PROBLEM	POSSIBLE CAUSE AND SOLUTION
<p>Lift will not Lower.</p>	<ul style="list-style-type: none"> • The down solenoid may be malfunctioning. • The maintenance leg could be installed. • The structural members may be in a bind. • The hose or tubing maybe obstructed or broken. Check for obstruction in the line. • The return filter may be clogged. (Vertical PU only) • The velocity fuse may be locked. Do not attempt to remove the velocity fuse. The following steps should be followed: <ol style="list-style-type: none"> 1. Remove the load from the lift. Inspect all fittings, hoses, and other hydraulic components for leads or damage. 2. If no leak or damage is noticed, attempt to pressurize the lifting cylinder by depressing the “UP” pushbutton (or optional footswitch) for a few seconds. Immediately release the “UP” button and depress the “DOWN” button. If the lift starts to lower, continue pressing the “DOWN” button until the lift is in the fully lowered position. 3. If the lift does not lower after trying Step 2, wait approximately 10 – 15 minutes for the pressure in the hydraulic system to equalize. Then, depress the “DOWN” pushbutton until the lift is in the fully lowered position. 4. Once the lift is in the fully lowered position, bleed the air from the hydraulic system by depressing the “DOWN” button. Hold the “DOWN” button for approximately 60 seconds. This step may need to be repeated several times to fully remove the air in the system by raising the lift to 50% of its travel and then lowering it. • Should the above steps not correct the problem, contact <i>Autoquip</i> to obtain instruction for further action.

TROUBLESHOOTING ANALYSIS

PROBLEM	POSSIBLE CAUSE AND SOLUTION
<p>Lift Raises Slowly.</p>	<ul style="list-style-type: none"> • The structural members of the lift may be binding. • Check for pinched hose or tubing. Where pipe is used, check for obstruction in the line. • The hydraulic line or hose may be leaking. • The oil viscosity is not suited for the environmental conditions. Refer to “Routine Maintenance” section for oil recommendations. • Check the oil level in the reservoir. • The motor voltage/wiring may be incorrect. • The suction screen may be clogged. Remove and clean the screen. Drain and replace the oil. • The suction line may be leaking air due to a loose fitting. Tighten as needed. • The breather holes in the reservoir fill plug may be clogged. Remove and clean. • The power unit pump may be defective.
<p>Lift lowers slowly.</p>	<ul style="list-style-type: none"> • The structural members of the lift are binding. • Check for pinched hose or tubing. Where pipe is used, check for obstruction in the line. • The oil viscosity is not suited for the environmental conditions. Refer to “Routine Maintenance” section for oil recommendations. • The return filter may be clogged due to dirt or damage. (Vertical PU) • The connecting hose on a Remote power unit maybe too small. See "Lift & Hose Installation" in Installation Instructions

TROUBLESHOOTING ANALYSIS

PROBLEM	POSSIBLE CAUSE AND SOLUTION
<p>Lift will not remain in Raised position.</p>	<ul style="list-style-type: none"> • The cylinder seals may be leaking. • The "Down" solenoid may not be seating. Remove the solenoid coil and check again. If the lift does not hold with the solenoid coil removed, the down valve cartridge should be removed and cleaned or replaced as necessary. • The oil line hose, or fittings may be leaking. Check and repair if necessary. • The “check valve” in the pump assembly may not be seating. This is indicated by the pump shaft and motor turning backward on their own with no power applied. Generally, this condition can be heard. Replace the pump assembly. • The Deltatrol regulator is not seating. (Vertical PU) • The Deltatrol check valve is not seating. (Vertical PU) • The return filter may be clogged. (Vertical PU)

TROUBLESHOOTING ANALYSIS

PROBLEM	POSSIBLE CAUSE AND SOLUTION
<p>Lift seems bouncy during operation.</p>	<ul style="list-style-type: none"> • Lower the lift to collapsed position and continue to hold the “DOWN” button an additional 10-30 seconds to bleed air from the cylinder. Do not confuse spongy or jerky operation with small surges that may occur when operating on rough or uneven floors • Check for oil starvation.
<p>Motor labors or heats excessively.</p>	<ul style="list-style-type: none"> • The voltage may be low. Check at the motor terminals while the pump is <u>running loaded</u>, not at the line source or while the pump is idling. Inadequate wiring can starve the motor even when the source voltage is ample. • Most of <i>Autoquip</i>'s standard motors are rated for intermittent duty (two minute run times with two minute rests). If a single-phase motor is being run more than 15 – 20 motor starts per hour, or a 3-phase motor more than 200 starts per hour, the problem may be motor over-heating. • Running against relief pressure unnecessarily due to over loaded lift or hitting physical stops. • Failure to observe the wiring diagram on the nameplate for proper voltage connections. Rewire. • The pump may be binding from oil starvation, which develops high internal heat. Check for low oil level or closed breather holes in the reservoir fill plug. The pump can be irreparably damaged by oil starvation and may have to be replaced.

LIMITED WARRANTY

The user is solely responsible for using this equipment in a safe manner and observing all of the safety guidelines provided in the Owner's Manual and on the warning labels provided with the lift. If you are unable to locate either the manual or the warning labels, please contact Autoquip or access www.autoquip.com for replacement downloads or information.

Autoquip Corporation expressly warrants that this product will be free from defects in material and workmanship under normal, intended use for a period of Two (2) Years for Labor, electrical, mechanical, and hydraulic components, parts or devices, and warrants the structure of the lift against breakage or failure for a period of Five (5) years. The warranty period begins from the date of shipment. When making a claim, immediately send your dealer or Autoquip notice of your claim. All claims must be received by Autoquip within the warranty time period. The maximum liability of Autoquip, under this Limited Warranty, is limited to the replacement of the equipment.

This warranty shall not apply to any Autoquip lift or parts of Autoquip lift that have been damaged or broken in transit/shipping, or due directly or indirectly to misuse, abuse, vehicle impact, negligence, faulty installation, fire, floods, acts of God, accidents, or that have been used in a manner contrary to the manufacturer's limitations or recommendations as stated in the manual, or that have been repaired, altered or modified in any manner outside of Autoquip Corp's manufacturing facility or which have not been expressly authorized by Autoquip.

Autoquip Corporation makes no warranty or representation with respect to the compliance of any equipment with state or local safety or product standard codes, and any failure to comply with such codes shall not be considered a defect of material or workmanship under this warranty. Autoquip Corporation shall not be liable for any direct or consequential damages resulting from such noncompliance.

Autoquip Corporation's obligation under this warranty is limited to the replacement or repair of defective components at its factory or another location at Autoquip Corp's discretion at no cost to the owner. This is owner's sole remedy. Replacement parts (with exception of electrical components) will be warranted for a period of ninety (90) days. Except as stated herein, Autoquip Corporation will not be liable for any loss, injury, or damage to persons or property, nor for direct, indirect, or consequential damage of any kind, resulting from failure or defective operation of said equipment. All parts used to replace defective material must be genuine Autoquip parts in order to be covered by this Limited Warranty.



AUTOQUIP CORP

P.O. Box 1058, Guthrie, OK 73044-1058

Telephone: (888) 811-9876 · (405) 282-5200

Fax: (405) 282-3302

www.autoquip.com