

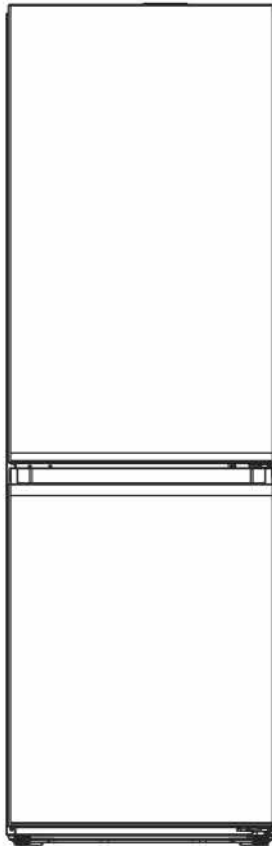

User Manual

HMDNB 5182WK
HMDNB 5182XK
HMDNB 5182WWDK
HMDNB 5182XWDK



CONTENTS

1. Safety	1
2. Proper use of the refrigerator	11
2.1 Placement	11
2.2 Leveling feet	12
2.3 Door right-left change	12
2.4 Changing the light	15
2.5 Starting	15
3. Structure and functions	16
3.1 Key components	16
3.2 Functions	17
4. Maintenance and care of the refrigerator	19
4.1 Overall cleaning	19
4.2 Cleaning the glass shelf	19
4.3 Defrosting	19
4.4 Out of operation	19
5. Troubleshooting	20

1. SAFETY

Thank you for purchasing this product.

Before using your refrigerator, please carefully read this instruction manual in order to maximize its performance. Store all documentation for subsequent use or for other owners. This product is intended solely for household use or similar applications such as:

- the kitchen area for personnel in shops, offices and other working environments
- on farms, by clientele of hotels, motels and other environments of a residential type
- at bed and breakfasts (B & B)
- for catering services and similar applications not for retail sale.

This appliance must be used only for purposes of storage of food, any other use is considered dangerous and the manufacturer will not be responsible for any omissions. Also, it is recommended that you take note of the warranty conditions.

SAFETY INFORMATION

Please read the operating and installation instructions carefully!

They contain important information on how to install, use and maintain the appliance.

The manufacturer is not liable if you fail to comply with the instructions and warnings.

Retain all documents for subsequent use or for the next owner.

- **Do not connect the appliance to the electricity supply until all packing and transit protectors have been removed. Keep children away from packaging and its parts.
Danger of suffocation from folding cartons and plastic film!**
- **Leave to stand for at least 4 hours before switching on the product, to allow compressor oil to settle if transported horizontally.**
- **Make sure there is no transport damage.**

- **Do not damage the refrigerant circuit.**
- **Maintain the ventilation openings in the appliance enclosure or in the built-in structure, free of obstruction.**
- **Never use water to wash the compressor position, wipe it with a dry cloth thoroughly after cleaning to prevent rust.**
- **Handle the appliance always with at least two persons because it is heavy.**
- **Install and level the appliance in an area suitable for its size and use.**
- **Make sure that the electrical information on the rating plate agrees with the power supply. If it does not, contact an electrician.**
- **The appliance is operated by a 220-240 VAC/50 Hz power supply. Abnormal voltage fluctuation may cause the appliance to fail to start, or damage to the temperature control or compressor, or there may be an abnormal noise when operating. In such case, an automatic regulator shall be mounted.**
- **Only for UK: The appliance's power cable is fitted with 3-cord (grounding) plug that fits a standard 3-cord (grounded) socket. Never cut off or dismount the third pin (grounding). After the appliance is installed, the plug should be accessible.**
- **Make sure that mains cable is not caught under**

the appliance during and after carrying/moving the appliance, to avoid the mains cable becoming cut or damaged. If the supply cord is damaged, it must be replaced by the manufacturer, its service agent or similarly qualified person in order to avoid a hazard.

- Do not install the appliance in humid, oily or dusty places, nor expose it to direct sunlight and to water.**
- Do not install the appliance near heaters or inflammable materials.**
- FOR appliances with a freezer compartment: if there is a power failure do not open the lid. Frozen food should not be affected if the failure lasts for less than the hours indicated on the rating label (Temperature rise time). If the failure is longer, then the food should be checked and eaten immediately or cooked and then refrozen.**
- If you find that the lid of the appliance is difficult to open just after you have closed it, don't worry. This is due to the pressure difference which will equalize and allow the lid to be opened normally after a few minutes.**
- Do not store medicines, bacteria or chemical agents in the appliance. This appliance is a household appliance, it is not recommended to store materials that require strict temperatures.**

- **Do not excessively pull or fold the power cord or touch the plug with wet hands.**
- **Do not store products which contain flammable propellant (e.g. spray cans) or explosive substances in the appliance. Risk of explosion!**
- **Do not place unstable articles (heavy objects, containers filled with water) on top of the refrigerator, to avoid personal injury caused by falling or electric shock caused by contact with water.**
- **Do not use electrical appliances inside the food storage compartments, unless they are of the type recommended by the manufacturer.**
- **Do not touch internal cooling elements, especially with wet hands, to avoid cracks or injuries.**
- **At risk here are children, people who have limited physical, mental or sensory abilities, as well as people who have inadequate knowledge concerning safe operation of the appliance.**
- **Check that children and vulnerable people have understood the hazards. A person responsible for safety must supervise or instruct children and vulnerable people who are using the appliance. Only children aged 8 years and above may use the appliance.**

- **Children should not play with the appliance.**
- **Children aged from 3 to 8 years are allowed to load and unload this appliance.**
- **FOR appliances with a freezer compartment: do not store bottled or canned liquids (especially carbonated drinks) in the freezer compartment. Bottles and cans may burst!**
- **FOR appliances with a freezer compartment: never put frozen food straight from the freezer compartment in your mouth. Risk of low-temperature burns!**
- **Keep plastic parts and the door seal free of oil and grease. Otherwise, plastic parts and the door seal will become porous.**
- **Before performing any operation, unplug the power cord from the power socket.**
- **Do not use mechanical devices or other means to accelerate the defrosting process, other than those recommended by the manufacturer.**
- **Do not use pointed or sharp-edged objects such as knives or forks to remove the frost.**
- **Never use hairdryers, electrical heaters or other such electrical appliances for defrosting.**
- **It is recommended to keep the plug clean, any excessive dust residues on the plug can be the cause fire.**
- **Do not try to repair, disassemble or modify the appliance by yourself. In case of repair please**

contact always our customer service.

- **Supervise children while the appliance is being cleaned or maintained.**
- **Do not clean the cold glass shelves with hot water. Sudden temperature change may cause the glass to break.**
- **WARNING: The tubes of the refrigeration circuit convey a small quantity of an environmentally friendly but flammable refrigerant (R600a) and insulating gas (cyclopentane). It does not damage the ozone layer and does not increase the greenhouse effect. If refrigerant escapes, it may injure your eyes or ignite.**
- **If the refrigerant circuit should be damaged:**
 - **Switch off the appliance and pull out the mains plug,**
 - **Keep naked flames and/or ignition sources away from the appliance,**
 - **Thoroughly ventilate the room for several minutes,**
 - **Inform customer service.**
- **WARNING: Do not damage the plug and/or the power cord; this could cause electrical shocks or fires.**
- **WARNING: Do not use multiple portable socket-outlets or portable power supplies. We do not recommend the use of extension leads and multi-way adapters.**

- **Do not attempt to sit or stand on the top of the appliance. You could injure yourself or damage it. This appliance is not designed for stacking with any other ones.**
- **The product is designed and built for domestic household use only.**
- **Only original parts supplied by the manufacturer may be used. The manufacturer guarantees that only these parts satisfy the safety requirements.**
- **Opening the door for long periods can cause a significant increase of the temperature in the compartments of the appliance.**
 - Clean regularly surfaces that can come in contact with food and accessible drainage systems.**
 - Clean water tanks if they have not been used for 48h; flush the water system connected to a water supply if water has not been drawn for 5 days.**
 - Store raw meat and fish in suitable containers in the refrigerator, so that it is not in contact with or drip onto other food.**
 - Two-star frozen-food compartments(if they are presented in the appliance) are suitable for storing pre-frozen food, storing or making ice-cream and making ice cubes.**
 - One-, two- and three -star compartments, if present in the appliance, are not suitable for**

the freezing of fresh food.

-If the appliance is left empty for long periods, switch off, defrost, clean, dry and leave the door open to prevent mould developing within the appliance.

- **FOR Wine Coolers: this appliance is intended to be used exclusively for the storage of wine**
- **FOR a free standing appliance: this refrigerating appliance is not intended to be used as a built-in appliance**
- **FOR appliances without a 4-star compartment: this refrigerating appliance is not suitable for freezing foodstuffs**

SCRAPPING OLD APPLIANCES



This appliance is marked according to the European directive 2012/19/EU on Waste Electrical and Electronic Equipment (WEEE).

WEEE contains both polluting substances (which can cause negative consequences for the environment) and basic components (which can be re-used). It is important to have WEEE subjected to specific treatments, in order to remove and dispose properly all pollutants, and recover and recycle all materials.

Individuals can play an important role in ensuring that WEEE does not become an environmental issue; it is essential to follow some basic rules:

- WEEE should not be treated as household waste;
- WEEE should be handed over to the relevant collection points managed by the municipality or by registered companies. In many countries, for large WEEE, home collection could be present.

In many countries, when you buy a new appliance, the old one may be returned to the retailer who has to collect it free of charge on a one-to-one basis, as long as the equipment is of equivalent type and has the same functions as the supplied equipment.

Conformity

By placing the **CE** mark on this product, we are confirming compliance to all relevant European safety, health and environmental requirements which are applicable in legislation for this product.

Guarantee

Minimum guarantee is: 2 years for EU Countries, 3 years for Turkey, 1 year for UK, 1 year for Russia, 3 years for Sweden, 2 years for Serbia, 5 years for Norway, 1 year for Morocco, 6 months for Algeria, Tunisia no legal warranty required.

Energy Saving

For better energy saving we suggest :

- Installing the appliance away from heat sources and not exposed to direct sunlight and in a well ventilated room.
- Avoid putting hot food into the refrigerator to avoid increasing the internal temperature and therefore causing continuous functioning of the compressor.
- Do not excessively stuff foods so as to ensure proper air circulation.
- Defrost the appliance in case there is ice to facilitate the transfer of cold.
- In case of absence of electrical energy, it is advisable to keep the refrigerator door closed.
- Open or keep the doors of the appliance open as little as possible
- Avoid adjusting the setting to temperatures too cold.
- Remove dust present on the rear of the appliance

2 Proper use of refrigerators

2.1 Placement

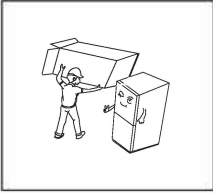

- Before use, remove all packing materials, including bottom cushions, foam pads and tapes inside of the refrigerator; tear off the protective film on the doors and the refrigerator body.

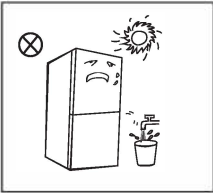

- Keep away from heat and avoid direct sunlight. Do not place the freezer in moist or watery places to prevent rust or reduction of insulating effect.
- Do not spray or wash the refrigerator; do not put the refrigerator in moist places easy to be splashed with water so as not to affect the electrical insulation properties of the refrigerator.

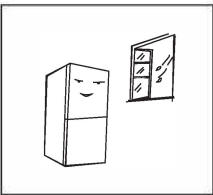

- The refrigerator is placed in a well-ventilated indoor place; the ground shall be flat, and sturdy (rotate left or right to adjust the wheel for levelling if unstable).

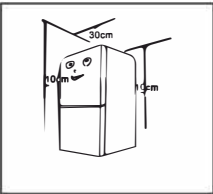

- The top space of the refrigerator shall be greater than 30cm, and the refrigerator should be placed against a wall with a free distance more than 10cm to facilitate heat dissipation.

! Precautions before installation:

Before installation or adjusting of accessories, it shall be ensured that the refrigerator is disconnected from power.

Precautions shall be taken to prevent fall of the handle from causing any personal injury.

Install this appliance at a location where the ambient temperature corresponds to the climate class indicated on the rating plate of the appliance:

- extended temperate: this refrigerating appliance is intended to be used at ambient temperatures ranging from 10 °C to 32 °C; (SN)

- temperate: this refrigerating appliance is intended to be used at ambient temperatures ranging from 16 °C to 32 °C; (N)

- subtropical: this refrigerating appliance is intended to be used at ambient temperatures ranging from 16 °C to 38 °C; (ST)

- tropical: this refrigerating appliance is intended to be used at ambient temperatures ranging from 16 °C to 43 °C; (T)

2.2 Leveling feet

Schematic diagram of the leveling feet

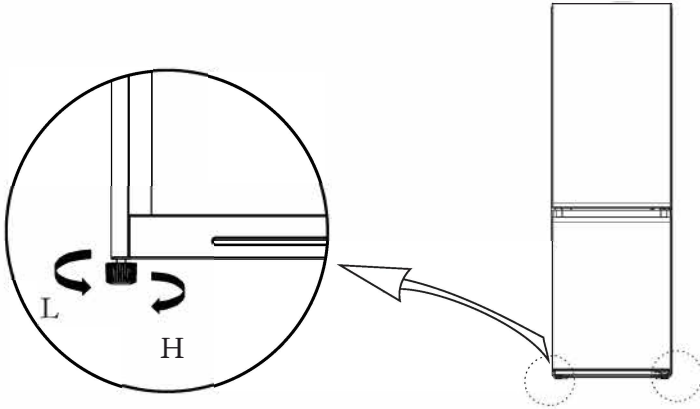







(The picture above is only for reference. The actual configuration will depend on the physical product or statement by the distributor)

Adjusting procedures:

- Turn the feet clockwise to raise the refrigerator;
- Turn the feet counterclockwise to lower the refrigerator;
- Adjust the right and left feet based on the procedures above to a horizontal level.

2.3 Door right-left change

List of tools to be provided by the user			
	Cross screwdriver		Putty knife
			thin-blade screwdriver
	5/16" socket and ratchet		Masking tape

Parts to be used for door reverse			
Number	Name	Num.	Note
1	Right upper hinge	1	Pre-installed on the refrigerator, removed when the door is reversed, and kept for future use
2	Upper right hinge cover	1	Pre-installed on the refrigerator, removed when the door is reversed, and kept for future use
3	Hole cover	1	Pre-installed on the refrigerator, still used when door is reversed
4	Door lamp switch	1	Pre-installed on the right upper hinge cover. remove it and install it on the left hinge cover
5	Lower hinge	1	Pre-installed on the refrigerator, still used when doo is reversed
6	Leveling feet	1	Pre-installed on the refrigerator, still used when door is reversed
7	Decorative cover	1	Pre-installed on the refrigerator, still used when door is reversed
8	Upper hinge cover	1	Pre-installed on the refrigerator, still used when door is reversed
9	Middle hinge	1	Pre-installed on the refrigerator, still used when doo is reversed
10	Middle decorative cover	1	In the attached plastic bag, take them out for use when door is reversed
11	Left upper hinge	1	In the attached plastic bag, take them out for use when door is reversed
12	Upper left hinge cover	1	In the attached plastic bag, take them out for use when door is reversed

1) Please power off this appliance before conduct this operation. Remove all food from door shelves.

2. Remove the upper left hinge cover decorative cover, upper right hinge cover and upper right hinge, and disconnect the signal line at the top of the box body

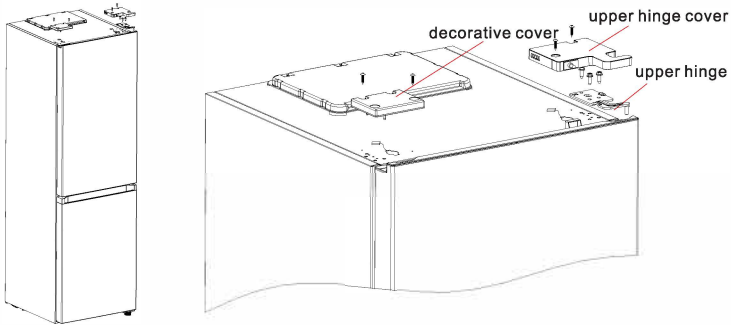

3. Remove the refrigerated door body (be careful not to lose small parts such as the shaft sleeve and stop on the door); Remove the middle hinge and remove the decorative cover of hinge hole on the other side.

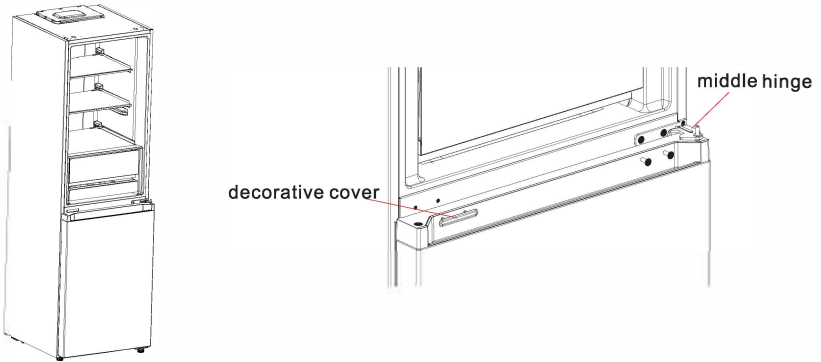

4. Remove the freezing door body (be careful not to lose small parts such as the shaft sleeve and stop on the door); Remove the hinge and adjust the angle. Remove and install the lower hinge shaft to the other side of the hinge, and install the modified lower hinge to the other side of the box.

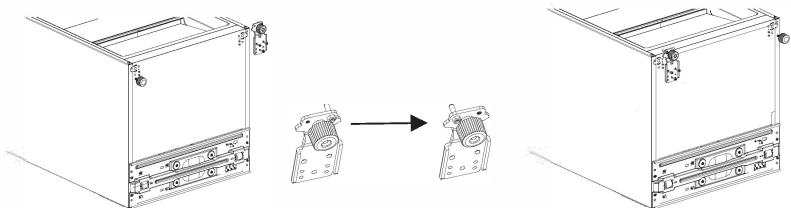

5. Change the refrigerator door:

- 1) Remove the door stop and cap of the upper end cover of the refrigeration door and install them at the left and right swap positions.
- 2) Remove the door self-locking, door stop and shaft sleeve of the refrigeration door, install them on the other side of the refrigeration door.

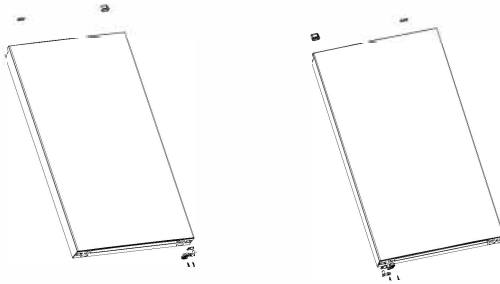

6. Change the freezing door:

- 1) Remove the shaft sleeve and cap of the upper end cover of the freezing door and install them at the left and right swap positions.
- 2) Remove the door self-locking, door stop and shaft sleeve of the freezing door, install them on the other side of the freezing door.

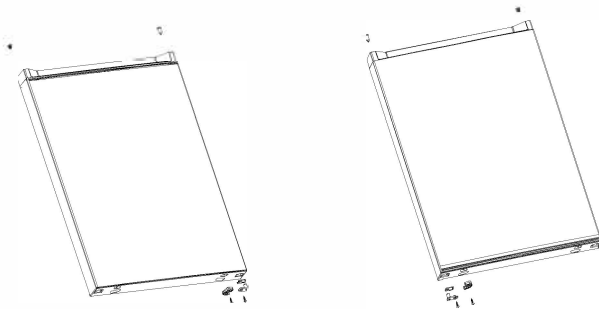

7. Install the replaced freezing door on the lower hinge, then install the middle hinge and cover the hinge hole decorative cover.

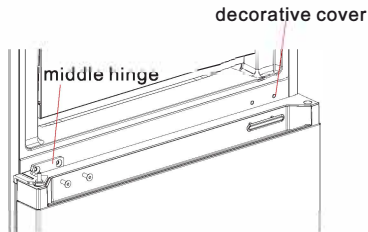
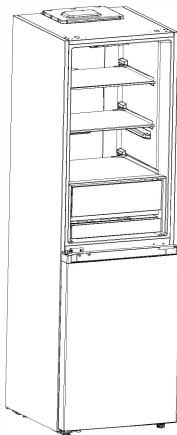

8. Remove the upper left hinge cover and upper left hinge from the accessory bag. Place the refrigerated door body on the middle hinge and install the upper left hinge. Connect the refrigerator left top door switch signal line to the left hinge switch line, replace the hinge decorative cover to the right side of the box body (note: when replacing the hinge decorative cover to the right side of the box body, the two inserts on the hinge decorative cover (as shown in the figure) shall be cut off)

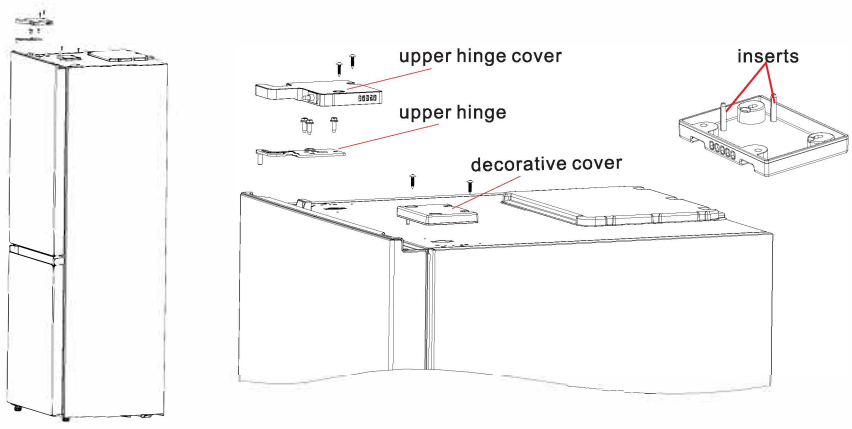

(The picture above is only for reference. The actual configuration will depend on the physical product or statement by the distributor)

2.4 Changing the Light

Any replacement or maintenance of the LED lamps is intended to be made by the manufacturer, its service agent or similar qualified person.

2.5 Starting



- Before initial start, keep the refrigerator still for two hours before connecting it to power supply.
- Before putting any fresh or frozen foods, the refrigerator shall have run for 2-3 hours, or for above 4 hours in summer when the ambient temperature is high.

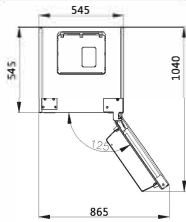

- Spare enough space for convenient opening of the doors and drawers or statement by the distributor.

3 Structure and functions

3.1 Key components

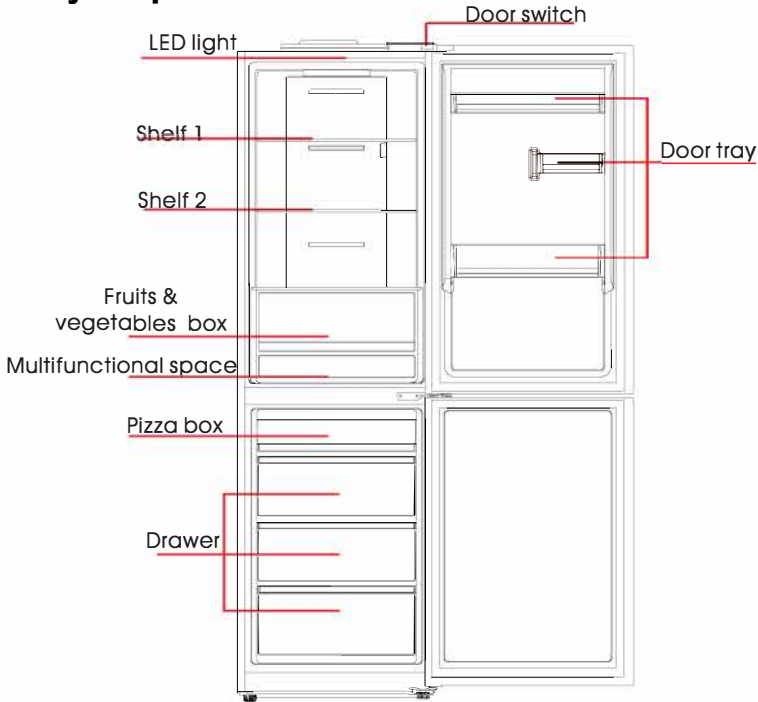

(The picture above is only for reference. The actual configuration will depend on the physical product or statement by the distributor)

The most energy saving configuration requires drawers, food box and shelves to be positioned in the product; please refer to above pictures.

Refrigerating chamber

- The Refrigerating Chamber is suitable for storage of a variety of fruits, vegetables, beverages and other food consumed in the short term. Cooking foods shall not be put in the refrigerating chamber until cooled to room temperature.
- Foods are recommended to be sealed up before putting into the refrigerator.
- The glass shelves can be adjusted up or down for a reasonable amount of storage space and easy use. The easy storage box is placed under the fruit&vegetable box at the factory and can be adjusted to under shelf 2. The box is of lower temperature when it's under the fruit&vegetable box and can be used to store meat or eggs for a short time. It's warmer when placed under shelf 2, and can be used to store foods which suit the fridge, in the mean while the multifunctional space can store beer and beverage, etc.

Freezing chamber

- The low temperature freezing chamber may keep food fresh for a long time and it is mainly used to store frozen foods and making ice.
- The freezing chamber is suitable for storage of meat, fish, rice balls and other foods not to be consumed in short term.
- Chunks of meat are preferably to be divided into small pieces for quick freezing and easy access. Please be noted food shall be consumed within the shelf time.
- The pizza box is designed to store pizza, icecream, etc. and can be turned over. When it's turned over, the room will be released and you can put some large food in the first drawer.

3.2 Functions

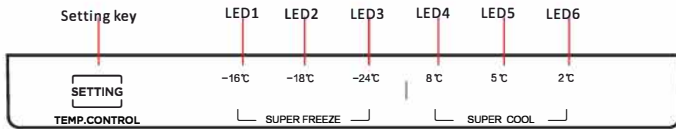

(The picture above is only for reference. The actual configuration will depend on the physical product or statement by the distributor)

1. When the power is on for the first time, full display shall last for 3 seconds, then enter into the normal operation display;

(When the power is on for the first time, the setting temperature of refrigerator and freezer is 5°C/-18°C respectively)

When there is a fault, the fault code is displayed; when there is no fault, the setting range of the refrigeration compartment is displayed.

The display screen is always on when the door is open while the display screen is always off when the door is closed;

2. Key operation

After each key operation of temperature adjustment, the corresponding set temperature flashes for 3S;

In the refrigeration temperature setting mode, long press the setting key  for 3S to switch to the freezing temperature setting mode;

In the freezing temperature setting mode, long press the setting key  for 3S to switch to the refrigeration temperature setting mode;

3. Locking and unlocking

The locking state shall be automatically entered after 30 seconds without key operation;
No manual lock/unlock settings;

4. When setting the refrigerating temperature, the temperature will cycle in the following order each time the setting key is pressed. In the super cool state, LED4 and LED6 will light up at the same time as shown below:



5. Freezer setting

When setting the freezer temperature, the temperature will cycle in the following order each time the setting key is pressed. In the super freeze state, LED1 and LED3 will light up at the same time, as shown below:



Recommended setting: Refrigerating chamber 4 °C, Freezing chamber - 18 °C.

6. When the door is opened, the display screen and the corresponding chamber lamp are on. There is no door opening prompt tone and door opening alarm.

7. Fault indication

The following warnings appearing on the display indicate corresponding faults of the refrigerator. Though the refrigerator may still have cold storage function with the following faults, the user shall contact a maintenance specialist for maintenance, so as to ensure optimized operation of the appliance.

Fault code	Fault description
LED1, LED6 flash	Refrigerator temperature sensor fault
LED1, LED3 flash	Freezer temperature sensor fault
LED1, LED5 flash	Frozen defrosting sensor fault
LED1, LED4 flash	Ambient temperature fault

Tips for storing food

- It's suggested to set the temperature at 4°C in the fridge compartment, and, whether possible, at -18°C in the freezer compartment.
- For most food categories, the longest storage time in the fridge compartment is achieved with colder temperatures. Since some particular products (as fresh fruits and vegetables) may be damaged with colder temperatures, it is suggested to keep them in the crisper drawers, whenever present. If not present, maintain an average setting of the thermostat.
- For frozen food, refer to the storage time written on the food packaging. This storage time is achieved whenever the setting respects the reference temperatures of the compartment (one-star -6°C, two stars -12°C, three stars -18°C)

4. Maintenance and care of the appliance

4.1 Overall cleaning

- Dusts behind the refrigerator and on the ground shall be timely cleaned to improve the cooling effect and energy saving.
- Check the door gasket regularly to make sure there are no debris. Clean the door gasket with a soft cloth dampened with soapy water or diluted detergent.
- The interior of the refrigerator should be cleaned regularly to avoid odor.
- Please turn off the power before cleaning interior, remove all foods, drinks ,shelves, drawers, etc.
- Use a soft cloth or sponge to clean the inside of the refrigerator, with two tablespoons of baking soda and a quart of warm water. Then rinse with water and wipe clean. After cleaning, open the door and let it dry naturally before turning on the power.
- For areas that are difficult to clean in the refrigerator (such as narrow sandwiches, gaps or corners), it is recommended to wipe them regularly with a soft rag, soft brush, etc. and when necessary, combined with some auxiliary tools (such as thin sticks) to ensure no contaminants or bacterials accumulation in these areas.
- Do not use soap, detergent, scrub powder, spray cleaner, etc., as these may cause odors in the interior of the refrigerator or contaminated food.
- Clean the bottle frame, shelves and drawers with a soft cloth dampened with soapy water or diluted detergent. Dry with a soft cloth or dry naturally.
- Wipe the outer surface of the refrigerator with a soft cloth dampened with soapy water, detergent, etc., and then wipe dry.
- Do not use hard brushes, clean steel balls, wire brushes, abrasives (such as toothpastes), organic solvents (such as alcohol, acetone, banana oil, etc.), boiling water, acid or alkaline items, which may damage the fridge surface and interior. Boiling water and organic solvents such as benzene may deform or damage plastic parts.
- Do not rinse directly with water or other liquids during cleaning to avoid short circuits or affect electrical insulation after immersion.



 Please unplug the refrigerator for defrost and cleaning.

4.2 Cleaning the glass shelf

- Remove the drawer on the glass shelf;
- Lift up the front of glass shelf(about 60°), and then pull out;
- Remove the glass shelf and clean as needed;
- The reverse operation is for installation of glass shelf.

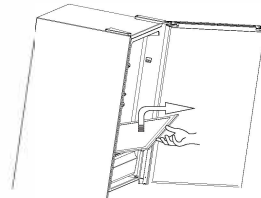

4.3 Defrosting

- The refrigerator is made based on the air-cooling principle and thus has automatic defrosting function. Frost formed due to change of season or temperature may also be manually removed by disconnection of the appliance from power supply or by wiping with a dry towel.

4.4 Out of operation

- Power failure: In case of power failure, even if it is in summer, foods inside the appliance can be kept for several hours; during the power failure, the times of door opening shall be reduced, and no more fresh food shall be put into the appliance.
- Long-time nonuse: The appliance shall be unplugged and then cleaned; then the doors are left open to prevent odor.
- Moving: Before the refrigerator is moved, take all objects inside out, fix the glass partitions, vegetable holder, freezing chamber drawers and etc. with tape, and tighten the leveling feet; close the doors and fix them with tape. During moving, the appliance shall not be laid upside down or horizontally, or be vibrated; the inclination during movement shall be no more than 45°.

 The appliance shall run continuously once it is started. Generally, the operation of the appliance shall not be interrupted; otherwise the service life may be impaired.

5 Trouble shooting

You may try to solve the following simple problems by yourself. If them cannot be solved, please contact the after-sales department.

Failed operation	<p>Check whether the appliance is connected to power or whether the plug is in well contact</p> <p>Check whether the voltage is too low</p> <p>Check whether there is a power failure or partial circuits have tripped</p>
Odor	<p>Odorous foods shall be tightly wrapped</p> <p>Check whether there is any rotten food</p> <p>Clean the inside of the refrigerator</p>
Long-time operation of the compressor	<p>Long operation of the refrigerator is normal in summer when the ambient temperature is high</p> <p>It is not recommended having too much food in the appliance at the same time</p> <p>Food shall get cool before being put into the appliance</p> <p>The doors are opened too frequently</p>
Light fails to get lit	<p>Check whether the refrigerator is connected to power supply and whether the illuminating light is damaged</p>
Doors cannot be properly closed	<p>The door is stuck by food packages</p> <p>The refrigerator is tilted</p>
Loud noise	<p>Check whether the floor is level and whether the refrigerator is placed stably</p> <p>Check whether accessories are placed at proper locations</p>
Door seal fails to be tight	<p>Remove foreign matters on the door seal</p> <p>Heat the door seal and then cool it for restoration (or blow it with an electrical drier or use a hot towel for heating)</p>
Water pan overflows	<p>There is too much food in the chamber or food stored contains too much water, resulting in heavy defrosting</p> <p>The doors are not closed properly, resulting in frosting due to entry of air and increased water due to defrosting</p>
Hot housing	<p>Heat dissipation of the built-in condenser via the housing, which is normal. When housing becomes hot due to high ambient temperature and storage of too much food, it is recommended to provide sound ventilation to facilitate heat dissipation.</p>
Surface condensation	<p>Condensation on the exterior surface and door seals of the refrigerator is normal when the ambient humidity is too high. Just wipe the condensate with a clean towel.</p>
Abnormal noise	<p>Buzz: The compressor may produce buzzes during operation, and the buzzes are loud particularly upon start or stop. This is normal.</p> <p>Creak: Refrigerant flowing inside of the appliance may produce creak, which is normal.</p>

AVAILABILITY OF SPARE PARTS

Thermostats, temperature sensors, printed circuit boards and light sources are available for a minimum period of seven years after placing the last unit of the model on the market.

Door handles, door hinges, trays and baskets for a minimum period of seven years and door gaskets for a minimum period of 10 year, after placing the last unit of the model on the market.

EN

FOR appliances without a 4-star compartment: this refrigerating appliance is not suitable for freezing foodstuffs

FOR a free standing appliance: this refrigerating appliance is not intended to be used as a built-in appliance

FOR Wine Coolers: this appliance is intended to be used exclusively for the storage of wine

FOOD STORAGE

Position different food in different compartments according to be below table

Refrigerator compartment	Type of food
Door or balconies of fridge compartment	<ul style="list-style-type: none">Foods with natural preservatives, such as jams, juices, drinks, condiments.Do not store perishable foods
Crisper drawers (salad drawer)	<ul style="list-style-type: none">Fruits, herbs and vegetables should be placed separately in the crisper binDo not store bananas, onions, potatoes, garlic in the refrigerator
Fridge shelf – middle	<ul style="list-style-type: none">Dairy products, eggs
Fridge shelf – top	<ul style="list-style-type: none">Foods that do not need cooking, such as ready-to-eat foods, deli meats, leftovers.
Freezer drawer(s)/tray	<ul style="list-style-type: none">Foods for long-term storageBottom drawer for raw meat, poultry, fishMiddle drawer for frozen vegetables, chips.Top tray for ice cream, frozen fruit, frozen baked goods.

- It's suggested to set the temperature at 4°C in the fridge compartment, and, where possible, at -18°C in the freezer compartment.
- For most food categories, the longest storage time in the fridge compartment is achieved with colder temperatures. Since some particular products (as fresh fruits and vegetables) may be damaged with colder temperatures, it is suggested to keep them in the crisper drawers, whenever present. If not present, maintain an average setting of the thermostat.
- For frozen food, refer to the storage time written on the food packaging. This storage time is achieved whenever the setting respects the reference temperatures of the compartment (one-star -6°C, two stars -12°C, three stars -18°C)

POSITIONING

Install the appliance at a location where the ambient temperature corresponds to the climate class indicated on the rating plate of the appliance:

- Extended temperate (SN): 'this refrigerating appliance is intended to be used at ambient temperatures ranging from 10 °C to 32 °C'
- Temperate (N): 'this refrigerating appliance is intended to be used at ambient temperatures ranging from 16 °C to 32 °C'
- Subtropical (ST): 'this refrigerating appliance is intended to be used at ambient temperatures ranging from 16 °C to 38 °C'

- Tropical (T): 'this refrigerating appliance is intended to be used at ambient temperatures ranging from 16 °C to 43 °C'

AVAILABILITY OF SPARE PARTS

"Thermostats, temperature sensors, printed circuit boards and light sources are available for a minimum period of seven years after placing the last unit of the model on the market.

Door handles, door hinges, trays and baskets for a minimum period of seven years and door gaskets for a minimum period of 10 year, after placing the last unit of the model on the market".

GUARANTEE

Minimum guarantee is: 2 years for EU Countries, 3 years for Turkey, 1 year for UK, 1 year for Russia, 3 years for Sweden, 2 years for Serbia, 5 years for Norway, 1 year for Morocco, 6 months for Algeria, Tunisia no legal warranty required.

TECHNICAL ASSISTANCE

To contact the technical assistance, visit our website: <https://corporate.haier-europe.com/en/>

Under the section "website", choose the brand of your product and your country. You will be redirected to the specific website where you can find the telephone number and form to contact the technical assistance

For further information about the product, please consult <https://eprel.ec.europa.eu/> or scan the QR on the energy label supplied with the appliance