

Eaton® 93E UPS

Generation 3
20–30 kVA (208/220V)
Installation and Operation Manual



p/n: 164000301
Revision 04

IMPORTANT SAFETY INSTRUCTIONS SAVE THESE INSTRUCTIONS

This manual contains important instructions that you should follow during installation and maintenance of the UPS and batteries. Please read all instructions before operating the equipment and save this manual for future reference.

CONSIGNES DE SÉCURITÉ IMPORTANTES – CONSERVER CES INSTRUCTIONS

Ce manuel comporte des instructions importantes que vous êtes invité à suivre lors de toute procédure d'installation et de maintenance des batteries et de l'onduleur. Veuillez consulter entièrement ces instructions avant de faire fonctionner l'équipement et conserver ce manuel afin de pouvoir vous y reporter ultérieurement.



IMPORTANT

To ensure you have the most up-to-date content and information for this product, please review the latest manual revision on our website, www.eaton.com/93E.

Eaton reserves the right to change specifications without prior notice. Modbus is a registered trademark of Schneider Automation, Inc. MOXA is a registered trademark and MGate is a trademark of MOXA, Inc. Spiralock is a registered trademark of Spiralock Corporation. KIRK is a registered trademark of Kirk Key Interlock company, LLC, a subsidiary of Halma plc. National Electrical Code and NEC are registered trademarks of National Fire Protection Association, Inc. ERIFLEX and FLEXIBAR are registered trademark of Erico International Corporation. All other trademarks are property of their respective companies.

©Copyright 2013–2020 Eaton, Raleigh, NC, USA. All rights reserved. No part of this document may be reproduced in any way without the express written approval of Eaton.

EATON END-USER LICENSE AGREEMENT

IMPORTANT, READ CAREFULLY. THIS END USER LICENSE AGREEMENT (THE "AGREEMENT") IS A BINDING CONTRACT BETWEEN YOU, THE END-USER (THE "LICENSEE") AND EATON INTELLIGENT POWER LIMITED, IRELAND, OR ONE OF ITS AFFILIATES ("EATON" OR "LICENSOR"), BY OPERATING THIS UNINTERRUPTIBLE POWER SUPPLY (UPS) PRODUCT INCLUDING SOFTWARE EMBEDDED IN IT (FIRMWARE), YOU, THE LICENSEE, ARE AGREEING TO BE BOUND BY THE TERMS, CONDITIONS, AND LIMITATIONS OF THIS AGREEMENT. READ THE TERMS AND CONDITIONS OF THIS AGREEMENT CAREFULLY BEFORE, INSTALLING OR OPERATING THE PRODUCT. IF YOU DO NOT AGREE TO THE TERMS OF THIS AGREEMENT, PROMPTLY RETURN THE UNUSED PRODUCT TO EATON.

1.0 DEFINITIONS

1.1 Documentation. "Documentation" means the user guides and manuals for the installation and use of the UPS, whether made available over the internet, provided in CD-ROM, DVD, hard copy or other form.

1.2 Firmware. "Firmware" means software programs that are embedded in the product for which Licensee is granted a license hereunder, the Documentation therefore and, to the extent available, Updates thereto. The Firmware is licensed hereunder in object code (machine-readable) form only except that certain software programs may include limited portions in source code (human-readable) form.

1.3 Update. "Update" means a subsequent release of the Firmware, if and when developed by Eaton. An Update does not include any release, new version, option, or future product, which Eaton licenses separately.

2.0 FIRMWARE LICENSE

2.1 Ownership. Eaton or its third party licensors retains all title, copyright and other proprietary rights in, and ownership of the Firmware regardless of the media upon which the original or any copy may be recorded or fixed.

2.2 License Grant. Eaton grants to Licensee a limited, revocable, non-exclusive, non-assignable license to use the Firmware in conjunction with the operation of the product to which the Firmware pertains or other products as described by Eaton in the Documentation. Licensee does not acquire any rights, express or implied, other than those expressly granted in this Agreement.

2.3 Restrictions and Requirements. Licensee will not, nor will it permit others to, modify, adapt, translate, reverse engineer, decompile, or disassemble the Firmware or any component thereof (including the Documentation), or create derivative works based on the Firmware (including the Documentation), except to the extent such foregoing restriction is prohibited by applicable law or applicable open source license to, and only to, any open source software component that is incorporated into the Firmware (if any). Copyright laws and international treaties protect the Firmware, including the Documentation. Unauthorized copying of the Firmware, the Documentation or any part thereof, is expressly prohibited. For avoidance of doubt, Eaton does not grant Licensee a license to any of Eaton's brands, logos, designs, trade dress, service marks, trademarks, domain names or trade names, in whole or in part. Licensee agrees to install or allow installation of all corrections of substantial defects, security patches, minor bug fixes and updates, including any enhancements, for the Firmware in accordance with the instructions and as directed by Eaton.

2.4 Transfer and Assignment Restrictions. Licensee will not sell, resell, assign, lease, sublicense, encumber, or otherwise transfer its interest in this Agreement or in the Firmware, or the Documentation in whole or in part, or allow any other person or entity, including any parent or subsidiary of Licensee or other subsidiary of Licensee's parent, to copy, distribute, or otherwise transfer the Firmware without the prior written consent of Eaton. Licensee may transfer the Firmware directly to a third party only in connection with the sale of the Eaton product in which it is installed.

3.0 TERMINATION

3.1 Termination. This Agreement and the license granted hereunder automatically terminates if Licensee breaches any provision of this Agreement. Eaton may terminate this license at any time with or without cause.

3.2 Effect of Termination. Immediately upon termination of this Agreement or the license granted hereunder, Licensee will cease using the product. The parties' rights and obligations under the following sections of this Agreement will survive termination of this Agreement: Article 1.0, Section 2.1, Section 2.3, Section 2.4, Article 3.0, Article 4.0 and Article 5.0.

4.0 INFRINGEMENT AND WARRANTIES

4.1 Infringement. If Licensee learns of a threat, demand, allegation, or indication that the UPS with its firmware infringes or misappropriates any third party intellectual property rights (including but not limited to any patent, copyright, trademark, trade dress, or trade secret) ("Intellectual Property Claim"), Licensee will notify Eaton promptly of such claim. Eaton may, in its sole discretion, elect to assume sole control of the defense and settlement of said Intellectual Property Claim and Licensee will provide reasonable information and assistance to Eaton for the defense of such claim.

4.2 Disclaimer of Warranties. THE FIRMWARE IS PROVIDED "AS IS" WITHOUT WARRANTY OF ANY KIND, EATON DOES NOT WARRANT THAT THE FIRMWARE WILL BE ERROR-FREE OR SECURE FROM UNAUTHORIZED ACCESS. THE LICENSEE EXPRESSLY ACKNOWLEDGES THAT TO THE EXTENT PERMITTED BY APPLICABLE LAW, THE USE OF THE PRODUCT IS AT LICENSEE'S SOLE RISK.

5.0 GENERAL PROVISIONS

5.1 Update Policy. Eaton may from time to time, but has no obligation to, create Updates of the Firmware or components thereof.

5.2 Limitation on Liability. NOTWITHSTANDING ANY PROVISION OF THIS AGREEMENT TO THE CONTRARY, LICENSEE EXPRESSLY UNDERSTANDS AND AGREES THAT EATON, ITS AFFILIATES, AND ITS LICENSORS, WILL NOT BE LIABLE FOR: (A) ANY DIRECT, INDIRECT, INCIDENTAL, SPECIAL, CONSEQUENTIAL OR EXEMPLARY DAMAGES WHICH MAY BE INCURRED BY LICENSEE OR ANY THIRD PARTY, HOWEVER CAUSED AND UNDER ANY THEORY OF LIABILITY THIS WILL INCLUDE, BUT NOT BE LIMITED TO, ANY LOSS OF PROFIT (WHETHER INCURRED DIRECTLY OR INDIRECTLY), ANY LOSS OF GOODWILL OR BUSINESS REPUTATION, ANY LOSS OF DATA SUFFERED, COST OF PROCUREMENT OF SUBSTITUTE GOODS OR SERVICES, OR OTHER INTANGIBLE LOSS; (B) ANY LOSS OR DAMAGE WHICH MAY BE INCURRED BY LICENSEE OR ANY THIRD PARTY. THESE LIMITATIONS ON EATON'S LIABILITY WILL APPLY WHETHER OR NOT EATON HAS BEEN ADVISED OF OR SHOULD HAVE BEEN AWARE OF THE POSSIBILITY OF ANY SUCH LOSSES ARISING.

TO THE EXTENT PERMITTED BY LAW, THE TOTAL LIABILITY OF EATON, ITS AFFILIATES, AND ITS LICENSORS, FOR ANY CLAIMS UNDER THESE TERMS, INCLUDING FOR ANY IMPLIED WARRANTIES, IS LIMITED TO THE AMOUNT PAID FOR THE UPS.

THIS SECTION 5.2 STATES EATON'S ENTIRE LIABILITY AND LICENSEE'S SOLE AND EXCLUSIVE REMEDY UNDER THIS AGREEMENT, AND IS SUBJECT TO ALL LIMITATIONS STATED IN SECTION 4.2.

5.3 Notices. All notices required to be sent hereunder will be in writing and will be deemed to

have been given when mailed by first class mail to the address shown below:

LICENSE NOTICES:
Eaton Intelligent Power Limited
Eaton House,
30 Pembroke Road,
Dublin 4,
D04 Y0C2,
Ireland

5.4 Severability. If any provision of this Agreement is held to be invalid or unenforceable, the remaining provisions of this Agreement will remain in full force.

5.5 Waiver. The waiver by either party of any default or breach of this Agreement will not constitute a waiver of any other or subsequent default or breach. Failure to enforce or delay in enforcing any provision of this Agreement will not constitute a waiver of any rights under any provisions of this Agreement.

5.6 Entire Agreement. This Agreement constitutes the complete agreement between the parties and supersedes all prior or contemporaneous agreements or representations, written or oral, concerning the subject matter of this Agreement. This Agreement may not be modified or amended except in a writing specifically referencing this Agreement and signed by a duly authorized representative of each party. No other act, document, usage or custom will be deemed to amend or modify this Agreement. The Firmware, or portions thereof, may also be subject to additional paper or electronic license agreements. In such cases, the terms of this Agreement will be supplemental to those in the additional agreements, to the extent not inconsistent with the additional agreements. If a copy of this Agreement in a language other than English is included with the Firmware or Documentation, it is included for convenience and the English language version of this Agreement will control.

5.7 Heirs, Successors, and Assigns. Each and all of the covenants, terms, provisions and agreements herein contained will be binding upon and inure to the benefit of the parties hereto and, to the extent expressly permitted by this Agreement, their respective heirs, legal representatives, successors and assigns.

5.8 Export Restrictions. Licensee agrees to comply fully with all relevant export laws and regulations of the United States and all other countries in the world (the "Export Laws") to assure that neither the Firmware nor any direct product thereof are (i) exported, directly or indirectly, in violation of Export Laws; or (ii) are intended to be used for any purposes prohibited by the Export Laws. Without limiting the foregoing, Licensee will not export or re-export the Firmware: (i) to any country to which the U.S. has embargoed or restricted the export of goods or services (see <http://www.treasury.gov/resource-center/sanctions/Programs/Pages/Programs.aspx>), or to any national of any such country, wherever located, who intends to transmit or transport the Firmware back to such country; (ii) to any end user who Licensee knows or has reason to know will utilize the Firmware in the design, development or production of nuclear, chemical or biological weapons; or (iii) to any end-user who has been prohibited from participating in U.S. export transactions by any federal agency of the U.S. government.

5.9 U.S. Government Restricted Rights. The Firmware is a "commercial item" as that term is defined at 48 C.F.R. § 2.101, consisting of "commercial computer software" and "commercial computer software documentation", as such terms are used in 48 C.F.R. § 12.212, and is provided to the U.S. Government only as a commercial end item. Consistent with 48 C.F.R. § 12.212 and 48 C.F.R. §§ 227.7202-1 through 227.7202-4, all U.S. Government End Users acquire the Firmware with only those rights set forth herein. Contractor/manufacturer is Eaton Corporation, 1000 Eaton Boulevard, Cleveland, Ohio 44122.

5.10 Third Party Intellectual Property Rights. The Firmware may contain components (including open source software components) that are owned by third parties ("Third Party Licensors") and are provided with, incorporated into, or embedded in, the Firmware pursuant to license arrangements between Eaton and such third parties. Third Party Licensor components in the Firmware are not licensed or warranted under the terms of this document, but are instead subject to the Third Party Licensors' license agreements. Licensee will not modify, delete, or obfuscate any copyright or other proprietary rights notices of Third Party Licensors contained in the Firmware.

5.11 Indemnity. Licensee shall defend, indemnify and hold Eaton and its officers, directors, employees, and agents harmless from and against all losses, damages, liabilities, claims, actions, and associated costs and expenses (including reasonable attorneys' fees and expenses) by reason of injury or death to any person or damage to any tangible or intangible property arising or resulting from the negligence or willful misconduct of the Licensee, its employees, contractors, or agents, in connection with Licensee's use of Firmware and Documentation.

Licensee shall be responsible for any breach of this Agreement by its officers, directors, employees, contractors, or agents. Licensee shall defend, indemnify, and hold Eaton and its officers, directors, employees, and agents harmless from and against any and all losses, damages, liabilities, claims, actions, and associated costs and expenses (including reasonable attorneys' fees and expenses) arising out of or in connection with any breach of this Agreement.

5.12 Open Source Software. The Firmware may contain certain components owned by Eaton that are provided with, incorporated into, linked to, or embedded in the Firmware that are subject to third party open source licenses ("Eaton Open Source Components"). Eaton Open Source Components are subject to the open source licenses corresponding to the particular software component. To the extent there are any conflicts between the terms of this Agreement and any open source license corresponding to Eaton Open Source Components or additional obligations by such open sources license that are not set forth in this Agreement, the terms of the open source license will control.

5.13 Confidentiality. Licensee acknowledges that confidential aspects of the Firmware (including any proprietary source code) are a trade secret of Eaton, the disclosure of which would cause substantial harm to Eaton that could not be remedied by the payment of damages alone and such confidential aspects of the Firmware shall not be disclosed to third parties without the prior written consent of Eaton. Accordingly, Eaton will be entitled to preliminary and permanent injunctive and other equitable relief for any breach of this Section 5.13.

5.14 Note on JAVA Support. The Firmware may contain support for programs written in JAVA. JAVA technology is not fault tolerant and is not designed, manufactured, or intended for use or resale as online control equipment in hazardous environments requiring fail-safe performance, such as in the operation of nuclear facilities, aircraft navigation or communications systems, air traffic control, direct life support machines, or weapons systems, in which the failure of JAVA technology could lead directly to death, personal injury, or severe physical or environmental damage. EATON DISCLAIMS ALL DAMAGES INCLUDING DIRECT, INDIRECT AND CONSEQUENTIAL DAMAGES RELATING TO THE FAILURE OF ANY SOFTWARE INCLUDING JAVA PROGRAMS AND/OR JAVA TECHNOLOGY.

5.15 Governing Law. This Agreement will be interpreted and enforced in accordance with the laws of Ireland, without regard to choice of law principles. Any claim or suit with respect to this Agreement shall be brought in the Courts of Ireland, unless mandatory law imposes otherwise.

Eaton EULA

Table of Contents

1 Introduction	1
1.1 UPS Standard Features	2
1.1.1 Installation Features	2
1.1.2 Control Panel	2
1.1.3 Customer Interface	2
1.1.4 High-Efficiency Normal Mode	2
1.1.5 Battery System	2
1.1.6 Advanced Battery Management	2
1.2 Options and Accessories	2
1.2.1 External Battery Cabinet Capability	3
1.2.2 External Battery Cabinet	3
1.2.3 Integrated Accessory Cabinet-Distribution	3
1.2.4 Sidecar Integrated Accessory Cabinet-Bypass	3
1.2.5 Integrated Transformer Cabinet	3
1.2.6 Integrated Accessory Cabinet-Tie	3
1.2.7 Integrated Accessory Cabinet-Tie and Bypass	3
1.2.8 Reduced Battery String Model	3
1.2.9 kVA Upgrades	4
1.2.10 Parallel System	4
1.2.11 Monitoring and Communication	4
1.2.12 Dual Feed	4
1.3 Basic System Configurations	4
1.4 Using This Manual	4
1.5 Conventions Used in This Manual	5
1.6 Symbols, Controls, and Indicators	5
1.7 For More Information	6
1.8 Getting Help	6
1.9 Equipment Registration	7
2 Safety Warnings	9
3 UPS Installation Plan and Unpacking	11
3.1 Creating an Installation Plan	11
3.2 Preparing the Site	11
3.2.1 Environmental and Installation Considerations	11
3.2.2 UPS System Power Wiring Preparation	17
3.2.3 UPS System Interface Wiring Preparation	21
3.3 Battery Type	22
3.4 Inspecting and Unpacking the UPS Cabinets	23
4 UPS System Installation	25

Table of Contents

4.1 Preliminary Installation Information	25
4.2 Unloading the UPS Cabinet from the Pallet	25
4.3 Installing Power Terminal Cover Base	29
4.4 External Battery Cabinet Installation	31
4.5 Integrated Transformer Cabinet Installation	31
4.6 Sidecar Integrated Accessory Cabinet-Bypass	32
4.7 Integrated Accessory Cabinet-Tie	32
4.8 Integrated Accessory Cabinet-Tie and Bypass	32
4.9 Integrated Accessory Cabinet-Distribution	32
4.10 External Power Wiring Installation	32
4.11 Installing Interface Wiring and Connections	36
4.11.1 Installing Building Alarm Wiring and Connections	36
4.11.2 Generator Interface Connections	42
4.11.3 Installing Parallel Pull Chain and CAN Control Wiring and Connections	43
4.11.4 Installing Mini-Slot Interface Wiring and Connections	44
4.12 Installing a REPO Switch	46
4.13 Connecting Internal Battery Strings	49
4.14 Initial Startup	52
4.15 Completing the Installation Checklist	52
5 Understanding UPS Operation	55
5.1 UPS System Overview	55
5.2 Single UPS	56
5.2.1 Modes	56
5.2.2 High-Efficiency Normal Mode	56
5.2.3 Standard Normal Mode	56
5.2.4 Bypass Mode	57
5.2.5 Battery Mode	58
6 UPS System Online Configurations	61
7 UPS Operating Instructions	65
7.1 UPS Controls and Indicators	65
7.1.1 Control Panel	66
7.1.2 Circuit Breakers	66
7.2 Using the Control Panel	66
7.2.1 Status Indicators	67
7.2.2 System Events	68
7.2.3 Using the LCD and Pushbuttons	68
7.2.4 Using the Menu	69
7.2.5 Mimic Screen	70
7.2.6 Display Menu Operation	71
7.2.7 System Controls	74

7.3 Single UPS Operation	75
7.3.1 Starting the UPS in High-Efficiency Normal Mode (Default Mode)	75
7.3.2 Starting the UPS in Bypass Mode	76
7.3.3 Transfer from Normal to Bypass Mode	77
7.3.4 Transfer from Bypass to Normal Mode	77
7.3.5 Transfer from HE Normal Mode to Standard Normal Mode	77
7.3.6 Transfer from Standard Normal Mode to HE Normal mode	78
7.3.7 UPS and Critical Load Shutdown	78
7.3.8 Charger Control	78
7.3.9 Battery Test	79
7.3.10 Using the UPS LOAD OFF Command	79
7.3.11 Using the Remote Emergency Power-off Switch	80
7.4 Multiple UPS Parallel Operation	81
7.4.1 Starting the Parallel UPS in High-Efficiency Normal Mode (Default Mode)	81
7.4.2 Starting the Parallel UPS in Bypass Mode	82
7.4.3 Transfer from Normal to Bypass Mode	83
7.4.4 Transfer from Bypass to Normal Mode	83
7.4.5 Transfer from HE Normal Mode to Standard Normal Mode	83
7.4.6 Transfer from Standard Normal Mode to HE Normal mode	84
7.4.7 Single UPS Shutdown	84
7.4.8 Single UPS Restart	84
7.4.9 UPS and Critical Load Shutdown	85
7.4.10 Charger Control	85
7.4.11 Battery Test	86
7.4.12 Using the UPS LOAD OFF Command	86
7.4.13 Using the Remote Emergency Power-off Switch	87
8 Communication	89
8.1 Mini-Slot Cards	89
8.2 XCP Communication Ports	91
8.3 Building Alarm Monitoring	91
8.4 Predict Pulse Remote Monitoring and Management Service	91
8.4.1 PredictPulse Service Features	91
8.4.2 Installing PredictPulse	92
9 UPS Maintenance	93
9.1 Important Safety Instructions	93
9.2 Performing Preventive Maintenance	93
9.2.1 DAILY Maintenance	94
9.2.2 MONTHLY Maintenance	94
9.2.3 PERIODIC Maintenance	95
9.2.4 ANNUAL Maintenance	95

Table of Contents

9.2.5 BATTERY Maintenance	96
9.3 Installing Batteries	96
9.4 Recycling the Used Battery or UPS	96
9.5 Maintenance Training	96
10 Product Specifications	97
10.1 Model Numbers	97
10.2 Specifications	97
10.2.1 UPS Input	97
10.2.2 UPS Output	97
10.2.3 UPS Environmental	98
10.2.4 UPS Internal Battery Runtimes (in Minutes) at Full load	98
10.2.5 UPS Internal Battery Plus External Battery Cabinet Runtimes (in Minutes) at Full load	99
11 Warranty	101

List of Figures

Figure 1.	Eaton 93E UPS (20–30 kVA)	1
Figure 2.	UPS Cabinet Dimensions (Front and Right Side Views).....	14
Figure 3.	UPS Cabinet Dimensions (Top and Bottom Views)	15
Figure 4.	UPS Cabinet Center of Gravity	16
Figure 5.	Remote EPO Switch Dimensions	17
Figure 6.	UPS Cabinet as Shipped on Pallet (wood container removed)	24
Figure 7.	Removing the Front Shipping Bracket.....	26
Figure 8.	Attaching the Ramp to the Pallet	27
Figure 9.	Removing the Rear Shipping Bracket.....	28
Figure 10.	Rolling the Cabinet Down the Ramp.....	29
Figure 11.	UPS Power Terminal Cover Parts.....	30
Figure 12.	UPS Power Terminal Cover Base Installation and Conduit Landing Wire Entry Locations	31
Figure 13.	Power Terminal Locations.....	34
Figure 14.	Power Terminal Detail.....	35
Figure 15.	Power Terminal Cover Top Installation.....	36
Figure 16.	Interface Terminal Locations.....	37
Figure 17.	Interface Terminal Detail (Terminal Cover Removed).....	38
Figure 18.	Building Alarm Terminal Block Connector Assignments	38
Figure 19.	Interface Terminal Cover.....	40
Figure 20.	Interface Conduit Landing and Wiring Channel.....	41
Figure 21.	Interface Wiring Access.....	41
Figure 22.	Pull Chain Terminal Block Connector Assignments	43
Figure 23.	Parallel UPS Control Wiring	45
Figure 24.	REPO Switch	46
Figure 25.	REPO Terminal Block Connector Assignments	47
Figure 26.	Normally-Open REPO Switch Wiring	48
Figure 27.	Normally-Closed REPO Switch Wiring	49
Figure 28.	Battery Location.....	50
Figure 29.	Battery Section.....	51
Figure 30.	Battery String Connections.....	52
Figure 31.	Main Elements of the UPS System	55
Figure 32.	Path of Current Through the UPS in standard Normal Mode	57
Figure 33.	Path of Current Through the UPS in Bypass Mode.....	58
Figure 34.	Path of Current Through the UPS in Battery Mode.....	59
Figure 35.	UPS System Online – 93E–20 Internal Battery (No External Battery Capability)	62
Figure 36.	UPS System Online – Internal Battery and External Battery Capable	63
Figure 37.	UPS System Online – Internal and External Batteries.....	64
Figure 38.	UPS Controls and Indicators	65
Figure 39.	UPS Breakers.....	66

List of Figures

Figure 40. UPS Control Panel 67

Figure 41. Parts of the LCD 69

Figure 42. Main Menu and Mimic Screen 70

Figure 43. Typical Initial Setup Screen 73

Figure 44. Typical System Control Screen 74

Figure 45. REPO Operation 81

Figure 46. Optional Mini-Slot Cards 90

Figure 47. XCP Communication Ports 91

Figure 48. Air Filter Location 95

List of Tables

Table 1.	Combined Altitude and Thermal Derating Factors	12
Table 2.	Air Conditioning or Ventilation Requirements During Full Load Operation.....	12
Table 3.	UPS Cabinet Weights	13
Table 4.	UPS Cabinet Clearances	13
Table 5.	Input/Output Ratings and External Wiring Requirements for the Eaton 93E–20, 93E–30/20, and 93E–30/30	18
Table 6.	UPS External Power Cable Terminations for the Eaton 93E–20, 93E–30/20, and 93E–30/30.....	19
Table 7.	Power Cable Conduit Requirements	20
Table 8.	Recommended Input Circuit Breaker Ratings	21
Table 9.	Recommended Bypass and Output Circuit Breaker Ratings.....	21
Table 10.	Battery Type.....	22
Table 11.	Building Alarm Connections	38
Table 12.	Pull Chain Connections	43
Table 13.	REPO Connections	47
Table 14.	Normally-Open REPO Wire Terminations.....	48
Table 15.	Normally-Closed REPO Wire Terminations.....	48
Table 16.	Status Indicators	67
Table 17.	Display Function Menu Map	70
Table 18.	Display Menu Operation	71
Table 19.	Command Menu Operation	74
Table 20.	Typical System Status Messages.....	75
Table 21.	Relay Card-MS and Industrial Relay Card IRC-MS Default Triggers	90

List of Tables

Chapter 1 Introduction

The Eaton® 93E 20–30 kVA uninterruptible power supply (UPS) is a true online, continuous-duty, transformerless, double-conversion, solid-state, three-phase system, providing conditioned and uninterruptible AC power to protect the customer's load from power failures.

The Eaton 93E 20–30 kVA online power protection system is used to prevent loss of valuable electronic information, minimize equipment downtime, and minimize the adverse effect on production equipment due to unexpected power problems.

The Eaton 93E 20–30 kVA UPS continually monitors incoming electrical power and removes the surges, spikes, sags, and other irregularities that are inherent in commercial utility power. Working with a building's electrical system, the UPS system supplies clean, consistent power that sensitive electronic equipment requires for reliable operation. During brownouts, blackouts, and other power interruptions, batteries provide emergency power to safeguard operation.

The UPS is housed in a single free-standing cabinet, with safety shields behind the door for hazardous voltage protection. [Figure 1](#) shows the Eaton 93E 20–30 kVA UPS.

NOTE 1 Startup may be performed by the customer's battery qualified electrical contractor for single (not parallel) UPS installations without any accessory cabinets such as an External Battery Cabinet.



NOTE 2 Startup and operational checks for parallel systems or installations with accessory cabinets must be performed by an authorized Eaton Customer Service Engineer, or the warranty terms specified on product's resources page become void. See [Chapter 11 Warranty](#) for details. This service is offered as part of the sales contract for the UPS. Contact an Eaton service representative in advance (usually a two-week notice is required) to reserve a preferred startup date.

Figure 1. Eaton 93E UPS (20–30 kVA)

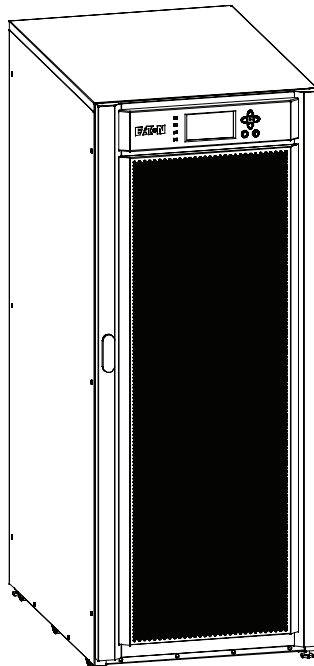

1.1 UPS Standard Features

The UPS has many standard features that provide cost-effective and consistently reliable power protection. The descriptions in this section provide a brief overview of the UPS standard features.

1.1.1 Installation Features

Power wiring can be routed to the back of the cabinet with connections made to easily accessible terminals. Control wiring can be installed using conduit through the bottom of power terminal cover base or by routing wiring through the power terminal cover base wiring channels and must be installed in accordance with Class 1 wiring methods.

1.1.2 Control Panel

The control panel, located on the front of the UPS, contains a liquid crystal display (LCD) and pushbutton switches to control the operation of the UPS and to display the status of the UPS system. See [Chapter 7 UPS Operating Instructions](#), for additional information.

1.1.3 Customer Interface

- **Building Alarm Monitoring** – Up to three inputs in the UPS are available to connect the facility's alarm system contacts. Some system configurations may limit the number of inputs available. The UPS uses these inputs to monitor the building alarms in addition to the UPS status.
- **Mini-Slot Communication Bays** – Two communication bays are standard equipment. One to two optional Mini-Slot® connectivity cards can be installed in the UPS module at any time. Mini-Slot cards are quickly installed at the rear of the UPS and are hot-pluggable.

For additional information on these topics, see [Chapter 8 Communication](#).

1.1.4 High-Efficiency Normal Mode

The 93E Series UPS offers a High-Efficiency (HE) normal mode with double-conversion on demand that allows the UPS to operate in standby bypass mode. This mode allows the 93E UPS to achieve 98% efficiency while still protecting the load. High-efficiency mode is the default normal operating mode. See [Chapter 7 UPS Operating Instructions](#), for additional information.

1.1.5 Battery System

The battery system provides emergency short-term backup power to safeguard operation during brownouts, blackouts, and other power interruptions. The battery system is equipped with lead-acid batteries.

The 93E–30/20 and 93E–30/30 UPS battery systems use internal batteries with External Battery Cabinet (EBC) capability. Up to two Eaton 93E External Battery Cabinets (EBCs) can be added to UPS system. The EBCs are connected in parallel with the internal batteries to provide extended run time.

The 93E–20 UPS (reduced battery sting model) battery system uses internal batteries only with no EBC capability.

All UPSs in a parallel system must have the same battery configuration.

1.1.6 Advanced Battery Management

A three-stage charging system increases battery service life by optimizing recharge time, and protects batteries from damage due to high current charging and inverter ripple currents. Charging at high currents can overheat and damage batteries.

1.2 Options and Accessories

Contact an Eaton sales representative for information about the following options.

1.2.1 External Battery Cabinet Capability

EBC capability provides the ability to add Eaton 93E EBCs to the UPS system in addition to the internal batteries. An internal UPS battery breaker and external battery terminal block are added, along with other internal parts allowing the connection of up to two EBCs.

1.2.2 External Battery Cabinet

Battery backup protection with additional runtime can be provide by equipping the UPS system with up to two External Battery Cabinets (EBCs) containing sealed lead-acid, maintenance-free batteries. The EBCs are available with two or three battery strings. Only EBC capable UPS systems can utilize EBCs. The EBCs are housed in single, free-standing cabinets designed for line-up-and-match installation, but may be installed separate from the UPS cabinet. The recommended installation location for adjacent battery cabinets is on the right side of the UPS cabinet.

1.2.3 Integrated Accessory Cabinet-Distribution

The Integrated Accessory Cabinet-Distribution (IAC-D) provides power distribution with a 42-pole distribution panel and up to three optional 3-pole 125A subfeed breakers. The IAC-D is housed in a single, free-standing cabinet designed for line-up-and-match installation, but may be installed separate from the UPS cabinet. The recommended installation location for an adjacent IAC-D is to the left of the UPS cabinet.

1.2.4 Sidecar Integrated Accessory Cabinet-Bypass

A Sidecar Integrated Accessory Cabinet-Bypass (SIAC-B) provides maintenance bypass functions. The SIAC-B is available in a three breaker configuration enabling power to completely bypass the UPS. The UPS can then be safely serviced or replaced without interrupting power to critical systems. A four breaker configuration is available to provide a convenient method for removing power from the UPS when using the maintenance bypass to supply the load. The SIAC-B is housed in a single cabinet designed to be attached directly to the UPS cabinet. The SIAC-B can be ordered for installation on the left side or the right side of the UPS cabinet to assist in integration with the overall system.

1.2.5 Integrated Transformer Cabinet

An single transformer Integrated Transformer Cabinet (ITC) provides three-phase 480 Vac input to three-phase 208Y/120 Vac output voltage transformation and isolation for input to the Eaton 93E UPS. An optional Dual transformer ITC adds three-phase 208 Vac input to three-phase 480Y/277 Vac output voltage transformation and isolation for output to the critical load. The ITC is housed in a single, free-standing cabinet designed for line-up-and-match installation, but may be installed separate from the UPS cabinet. The recommended installation location for an adjacent ITC is to the left of the UPS cabinet.

1.2.6 Integrated Accessory Cabinet-Tie

An Integrated Accessory Cabinet-Tie (IAC-T) provides the ability to parallel up to four UPSs together for increased capacity and/or redundant capability. The IAC-T is housed in a single, free-standing cabinet designed for line-up-and-match installation, but may be installed separate from the UPS cabinet. The recommended installation location for an adjacent IAC-T is to the left of the UPS cabinet.

1.2.7 Integrated Accessory Cabinet-Tie and Bypass

An Integrated Accessory Cabinet-Tie and Bypass (IAC-TB) provides the ability to parallel two UPSs together for increased capacity and/or redundant capability. In addition, maintenance bypass functions enable power to completely bypass the UPS power module. The IAC-T is housed in a single, free-standing cabinet designed for line-up-and-match installation, but may be installed separate from the UPS cabinet. The recommended installation location for an adjacent IAC-T is to the left of the UPS cabinet.

1.2.8 Reduced Battery String Model

The Eaton 93E-20 model is configured with four battery strings instead of six to optimize the run time for 20 kVA with a subsequent reduction in cost and weight. Reduced battery string models are non-EBC capable. If

increased battery run time is required in the future, an extended run battery upgrade kit is available to increase the internal battery system to six strings.

The Eaton 93E–20 is also upgradable to full EBC capability with the addition of a 93E–20 to 93E–30/20 field upgrade kit converting the Eaton 93E–20 to a Eaton 93E–30/20 or to an Eaton 93E–30/30 with a 93E–20 to 93E30/30 field upgrade kit.

1.2.9 kVA Upgrades

The Eaton 93E–30/20 is firmware upgradable by an authorized Eaton Customer Service Engineer to an Eaton 93E–30/30.

1.2.10 Parallel System



NOTE 1 All UPSs in a parallel system must have the same battery configuration.

NOTE 2 The SIAC-B cannot be used in a parallel system.

A parallel UPS system with up to four UPSs can be installed to provide a parallel capacity and/or redundant system. This load sharing system provides more capacity than a single UPS, and can provide backup, depending on the load and configuration. In addition, when one UPS is taken out of service for maintenance or is not operating properly, a redundant UPS continues to supply uninterrupted power to the critical load. A Controller Area Network (CAN) provides connectivity for system metering and operational mode control. The parallel system consists of two to four UPSs each with a parallel CAN, and either a IAC-T or IAC-TB to act as a tie point and to control the output.

1.2.11 Monitoring and Communication

Mini-Slot Cards – Optional Mini-Slot® cards support several protocols, such as SNMP, HTTP, Modbus® and RS232.

See [Chapter 8 Communication](#), for additional information on monitoring and communication features.

1.2.12 Dual Feed

Optional dual-feed input terminals are available to provide a separate bypass feed to the UPS.

1.3 Basic System Configurations

The following basic UPS system configurations are possible:

- Single UPS with reduced string internal batteries
- Single UPS with internal batteries and EBC capability
- Single UPS with internal batteries, EBC capability, and one or two external battery cabinets
- Single UPS with reduced string internal batteries and accessory cabinets
- Single UPS with internal batteries, EBC capability, and accessory cabinets
- Single UPS with internal batteries, EBC capability and one or two external battery cabinets and accessory cabinets

The UPS system configuration can be enhanced by adding optional accessories such as a Remote Emergency Power-off (REPO) control or Mini-Slot communication cards.

1.4 Using This Manual

This manual describes how to install and operate the Eaton 93E 20–30 kVA. Read and understand the procedures described in this manual to ensure trouble-free installation and operation. In particular, be thoroughly familiar with the REPO procedure detailed in [Chapter 7 UPS Operating Instructions](#).

The information in this manual is divided into sections and chapters. The system, options, and accessories being installed dictate which parts of this manual should be read. At a minimum, [Chapter 1 Introduction](#) through [Chapter 4 UPS System Installation](#) and [Chapter 7 UPS Operating Instructions](#) should be examined.

Read through each procedure before beginning the work. Perform only those procedures that apply to the UPS system being installed or operated.

1.5 Conventions Used in This Manual

This manual uses these type conventions:

- **Bold type** highlights important concepts in discussions, key terms in procedures, and menu options, or represents a command or option that you type or enter at a prompt.
- *Italic type* highlights notes and new terms where they are defined.
- `Screen type` represents information that appears on the screen or LCD.

Icon	Description
Note	Information notes call attention to important features or instructions.
[Keys]	Brackets are used when referring to a specific key, such as [Enter] or [Ctrl].

In this manual, the term UPS refers only to the UPS cabinet and its internal elements. The term UPS system refers to the entire power protection system – the UPS cabinet, an external battery system, and options or accessories installed.

1.6 Symbols, Controls, and Indicators

The following are examples of symbols used on the UPS or accessories to alert you to important information:



RISK OF ELECTRIC SHOCK - Observe the warning associated with the risk of electric shock symbol.



CAUTION: REFER TO OPERATOR'S MANUAL - Refer to your operator's manual for additional information, such as important operating and maintenance instructions.



This symbol indicates that you should not discard the UPS or the UPS batteries in the trash. This product contains sealed, lead-acid batteries and must be disposed of properly. For more information, contact your local recycling/reuse or hazardous waste center.



This symbol indicates that you should not discard waste electrical or electronic equipment (WEEE) in the trash. For proper disposal, contact your local recycling/reuse or hazardous waste center.

1.7 For More Information

Refer to the *Eaton 93E External Battery Cabinet Installation Manual* for the following additional information:

- Installation instructions, including site preparation, planning for installation, wiring and safety information, and detailed illustrations of cabinets with dimensional and connection point drawings

Refer to the *Eaton 93E Integrated Accessory Cabinet-Distribution Installation and Operation Manual* for the following additional information:

- Installation instructions, including site preparation, planning for installation, wiring and safety information, and detailed illustrations of cabinets with dimensional and connection point drawings
- Operation, including breakers, standard features and optional accessories, procedures for using the tie and bypass functions, and information about maintenance

Refer to the *Eaton 93E Integrated Transformer Cabinet Installation Manual* for the following additional information:

- Installation instructions, including site preparation, planning for installation, wiring and safety information, and detailed illustrations of cabinets with dimensional and connection point drawings

Refer to the *Eaton 93E Integrated Accessory Cabinet-Tie and Bypass Installation and Operation Manual* for the following additional information:

- Installation instructions, including site preparation, planning for installation, wiring and safety information, and detailed illustrations of cabinets with dimensional and connection point drawings
- Operation, including breakers, standard features and optional accessories, procedures for using the tie and bypass functions, and information about maintenance

Refer to the *Eaton 93E Sidecar Integrated Accessory Cabinet-Bypass Installation and Operation Manual* for the following additional information:

- Installation instructions, including site preparation, planning for installation, wiring and safety information, and detailed illustrations of cabinets with dimensional and connection point drawings
- Operation, including breakers, standard features and optional accessories, procedures for using the tie and bypass functions, and information about maintenance

Visit www.eaton.com/powerquality or contact an Eaton service representative for information on how to obtain copies of these manuals.

1.8 Getting Help

If help is needed with any of the following:

- Scheduling initial startup
- Regional locations and telephone numbers
- A technical question about any of the information in this manual
- A question this manual does not answer

Please call the Customer Reliability Center at:

United States:

1-800-843-9433

Canada:

1-800-461-9166 ext 260

All other countries:

Call your local service representative

Please use the following e-mail address for manual comments, suggestions, or to report an error in this manual:

E-ESSDocumentation@eaton.com

1.9 Equipment Registration

Please visit www.eaton.com/pg/register to register your new Eaton UPS / Eaton UPS Accessory.

Model Number:

Serial Number:

Chapter 2 Safety Warnings

IMPORTANT SAFETY INSTRUCTIONS SAVE THESE INSTRUCTIONS

This manual contains important instructions that should be followed during installation and maintenance of the UPS and batteries. Read all instructions before operating the equipment and save this manual for future reference.

The UPS is designed for industrial or computer room applications, and contains safety shields behind the door and front panels. However, the UPS is a sophisticated power system and should be handled with appropriate care.



DANGER

This UPS contains LETHAL VOLTAGES. All repairs and service should be performed by AUTHORIZED SERVICE PERSONNEL ONLY. There are NO USER SERVICEABLE PARTS inside the UPS.



WARNING

- The UPS is powered by its own energy source (batteries). The output terminals may carry live voltage even when the UPS is disconnected from an AC source.
 - To reduce the risk of fire or electric shock, install this UPS in a temperature and humidity controlled, indoor environment, free of conductive contaminants. Ambient temperature must not exceed 30°C (86°F). Do not operate near water or excessive humidity (95% maximum). The system is not intended for outdoor use.
 - As a result of the connected loads high leakage current is possible. Connection to earth ground is required for safety and proper product operation. Do not check UPS operation by any action that includes removal of the earth (ground) connection with loads attached.
 - Ensure all power is disconnected before performing installation or service.
 - Batteries can present a risk of electrical shock or burn from high short-circuit current. The following precautions should be observed: 1) Remove watches, rings, or other metal objects; 2) Use tools with insulated handles; 3) Do not lay tools or metal parts on top of batteries; 4) Wear voltage rated gloves and electrical hazard footwear.
 - ELECTRIC ENERGY HAZARD. Do not attempt to alter any UPS or battery wiring or connectors.
Attempting to alter wiring can cause injury.
 - Do not open or mutilate batteries. Released electrolyte is harmful to the skin and eyes. It may be toxic.
-

 **CAUTION**

- Installation or servicing should be performed by qualified service personnel knowledgeable of UPS and battery systems, and required precautions. Keep unauthorized personnel away from equipment. Consider all warnings, cautions, and notes before installing or servicing equipment. **DO NOT DISCONNECT** the batteries while the UPS is in Battery mode.
- Replace batteries with the same number and type of batteries as originally installed with the UPS.
- Disconnect the charging source prior to connecting or disconnecting terminals.
- Determine if the battery is inadvertently grounded. If it is, remove the source of the ground. Contacting any part of a grounded battery can cause a risk of electric shock. An electric shock is less likely if you disconnect the grounding connection before you work on the batteries.
- Proper disposal of batteries is required. Refer to local codes for disposal requirements.
- Do not dispose of batteries in a fire. Batteries may explode when exposed to flame.
- Keep the UPS door closed and front panels installed to ensure proper cooling airflow and to protect personnel from dangerous voltages inside the unit.
- Do not install or operate the UPS system close to gas or electric heat sources.
- Lead-acid batteries can present a risk of fire because they generate hydrogen gas. Do not smoke when near batteries. Do not cause flame or spark in battery area. Discharge static electricity from body before touching batteries by first touching a grounded metal surface.
- The operating environment should be maintained within the parameters stated in this manual.
- Keep surroundings uncluttered, clean, and free from excess moisture.
- Observe all DANGER, CAUTION, and WARNING notices affixed to the inside and outside of the equipment.

 **AVERTISSEMENT!**

- Les batteries peuvent présenter un risque de décharge électrique ou de brûlure par des courts-circuits de haute intensité. Prendre les précautions nécessaires.
- Pour le remplacement, utiliser le même nombre et modèle des batteries.

CONSIGNES DE SÉCURITÉ IMPORTANTES – CONSERVER CES INSTRUCTIONS

- Une mise au rebut réglementaire des batteries est obligatoire. Consulter les règlements en vigueur dans votre localité.
- Ne jamais jeter les batteries au feu. L'exposition aux flammes risque de les faire exploser.
- Les accumulateurs au plomb-acide peuvent représenter un risque d'incendie, car ils génèrent de l'hydrogène gazeux. Ne pas fumer près des accumulateurs. Ne pas produire de flamme ou d'étincelle dans la zone de l'accumulateur. Dissiper l'électricité statique de votre corps en touchant une surface reliée à la terre avant de toucher les accumulateurs.

Chapter 3 UPS Installation Plan and Unpacking

Use the following basic sequence of steps to install the UPS:

1. Create an installation plan for the UPS system.
2. Prepare your site for the UPS system.
3. Inspect and unpack the UPS cabinet.
4. Unload and install the UPS cabinet, and wire the system.
5. Install features, accessories, or options, as applicable.
6. Complete the Installation Checklist.
7. Have authorized service personnel perform preliminary operational checks and start up the system.

NOTE 1 Startup may be performed by the customer's battery qualified electrical contractor for single (not parallel) UPS installations without any accessory cabinets such as an External Battery Cabinet.

 **NOTE 2** Startup and operational checks for parallel systems or installations with accessory cabinets must be performed by an authorized Eaton Customer Service Engineer, or the warranty terms specified on product's resources page become void. See [Chapter 11 Warranty](#) for details. This service is offered as part of the sales contract for the UPS. Contact an Eaton service representative in advance (usually a two-week notice is required) to reserve a preferred startup date.

3.1 Creating an Installation Plan

Before installing the UPS system, read and understand how this manual applies to the system being installed. Use the procedures and illustrations in paragraph [3.2 Preparing the Site](#) and [Chapter 4 UPS System Installation](#) to create a logical plan for installing the system.

3.2 Preparing the Site

For the UPS system to operate at peak efficiency, the installation site should meet the environmental parameters outlined in this manual. The operating environment must meet the weight, clearance, and environmental requirements specified.

3.2.1 Environmental and Installation Considerations

The UPS system installation must meet the following guidelines:

- The system must be installed on a level floor suitable for computer or electronic equipment.
- The system must be operated at an altitude no higher than 1500m (5000 ft) without derating. See [Table 1](#) for altitude and thermal derating requirements. For additional assistance with high altitude operation, contact an Eaton service representative (see paragraph [1.8 Getting Help](#)).
- The system must be installed in a temperature and humidity controlled indoor area free of conductive contaminants.



CAUTION

Do not expose the UPS to overly aggressive environments, like salt mist or corrosive gases. High relative humidity accelerates the effects of contaminants. The UPS should be installed in a G1 environment (based on ANSI/ISA S-71.04 classifications). If the UPS is used in a more aggressive environment, it can cause reduced product life and possibly early failure. If the installation location does not meet the recommended environment, contact Eaton service representative for further information (see paragraph [1.8 Getting Help](#)).

Failure to follow guidelines may void your warranty.

The basic environmental requirements for operation of the UPS are:

- Ambient Temperature Range: 0–30°C (32–86°F)
- Recommended Operating Range: 20–25°C (68–77°F)
- Maximum Relative Humidity: 5–95%, noncondensing

 **CAUTION**

If battery systems are located in the same room as the UPS, the battery manufacturer's environmental requirements should be followed if they are more stringent than the UPS requirements. Operating temperatures above the recommended range will result in decreased battery life and performance, and may reduce or void the battery warranty.

Table 1. Combined Altitude and Thermal Derating Factors

Altitude Meters (Feet)	Derating Factor			
	40°C Ambient	35°C Ambient	30°C Ambient	25°C Ambient
1000 (3300)	0.82	0.91	—	—
1500 (5000)	0.78	0.86	1.00	—
2000 (6600)	0.74	0.82	0.95	—
2500 (8300)	0.70	0.78	0.91	1.00
3000 (10000)	0.67	0.74	0.86	0.95
3500 (11600)	0.63	0.70	0.82	0.91
4000 (13200)	0.59	0.67	0.78	0.86
4500 (15000)	0.54	0.63	0.74	0.82
5000 (16500)	0.50	0.59	0.70	0.78

NOTE Altitude derating based on interpolation of IEC 62040-3 Ed1. Thermal derating based on thermal testing in accordance with UL 60950.

The UPS ventilation requirements are shown in [Table 2](#).

Table 2. Air Conditioning or Ventilation Requirements During Full Load Operation

Model	Rating	Input Voltage	Output Voltage	Heat Rejection BTU/hr x1000 (kg-cal/hr)	Minimum Required Cooling Air Flow
Eaton 93E–20	20 kVA	208/220	208/220	4.647 (1171)	125 liters/sec (264 cfm)
Eaton 93E–30/20					
Eaton 93E–30/30	30 kVA	208/220	208/220	6.970 (1756)	

The UPS equipment operating environment must meet the weight requirements shown in [Table 3](#) and the size requirements shown in [Figure 2](#) through [Figure 5](#). Dimensions are in millimeters (inches).

Table 3. UPS Cabinet Weights

Model	Weight kg (lb)		
	Shipping	Installed	Point Loading
Eaton 93E–20 with internal batteries	441 (972)	377 (831)	6 at 63 (139)
Eaton 93E–30/20 with internal batteries	540 (1190)	476 (1049)	6 at 79 (175)
Eaton 93E–30/30 with internal batteries			
Eaton 93E–20 without batteries	261 (575)	Not Applicable	Not Applicable
Eaton 93E–30/20 without batteries			
Eaton 93E–30/30 without batteries			

The UPS cabinet uses forced air cooling to regulate internal component temperature. Air inlets are in the front of the cabinet and outlets are in the back of the cabinet. Allow clearance in front of and in back of the cabinet for proper air circulation. The clearances required around the UPS cabinet are shown in [Table 4](#).

Table 4. UPS Cabinet Clearances

From Top of Cabinet	304.8 mm (12") working space
From Front of Cabinet	Minimum 550 mm (21.6") for cooling air intake and door swing Recommended 914.4 mm (36") working space
From Back of Cabinet	Minimum of 203.2 mm (8") for operation Recommended 914.4 mm (36") for service Clearances must comply with all applicable national and local codes. Flexible conduit may be used to adjust between required operation and service clearances.
From Right Side of Cabinet	None Required
From Left Side of Cabinet	None Required

Figure 2. UPS Cabinet Dimensions (Front and Right Side Views)

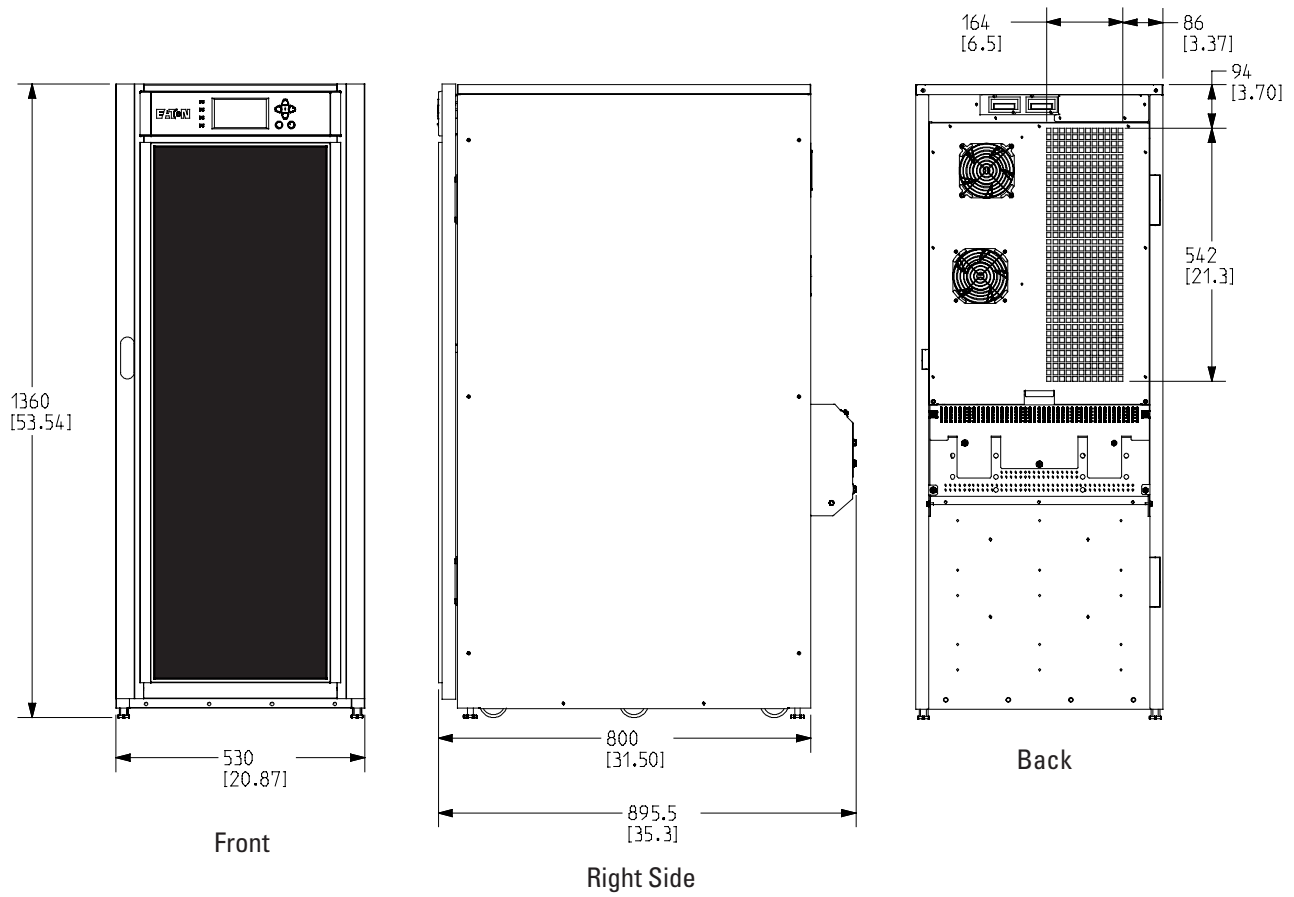

Dimensions are in millimeters [inches]

Figure 3. UPS Cabinet Dimensions (Top and Bottom Views)

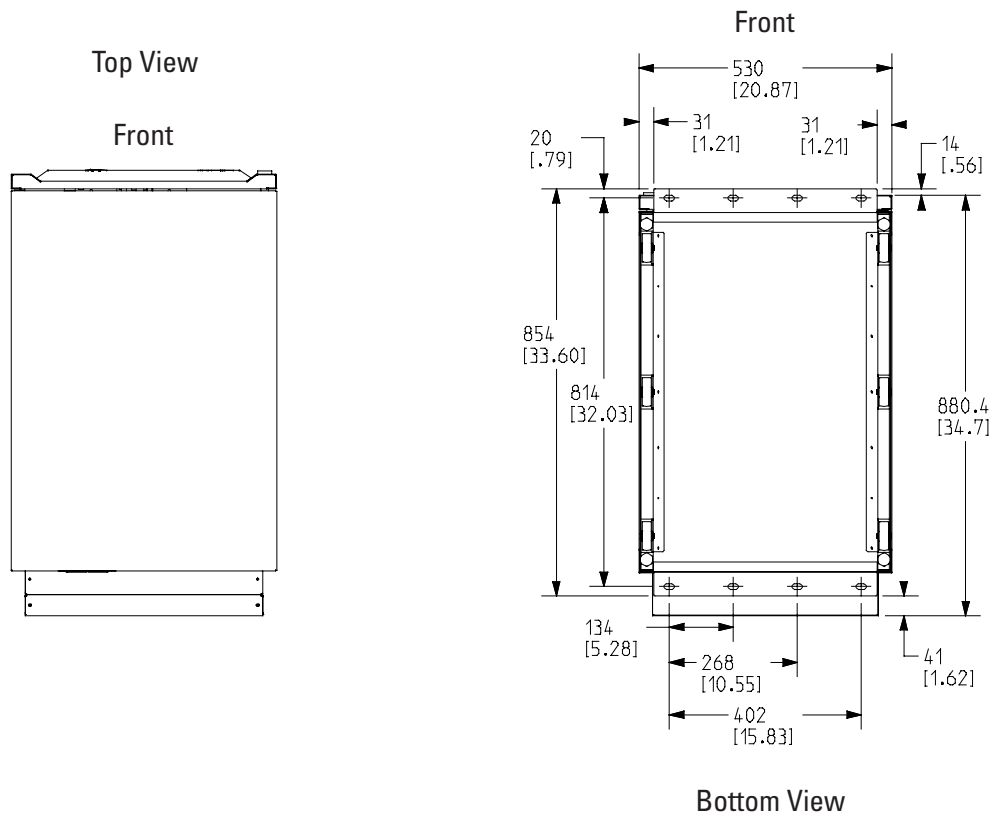

Dimensions are in millimeters [inches]

Figure 4. UPS Cabinet Center of Gravity

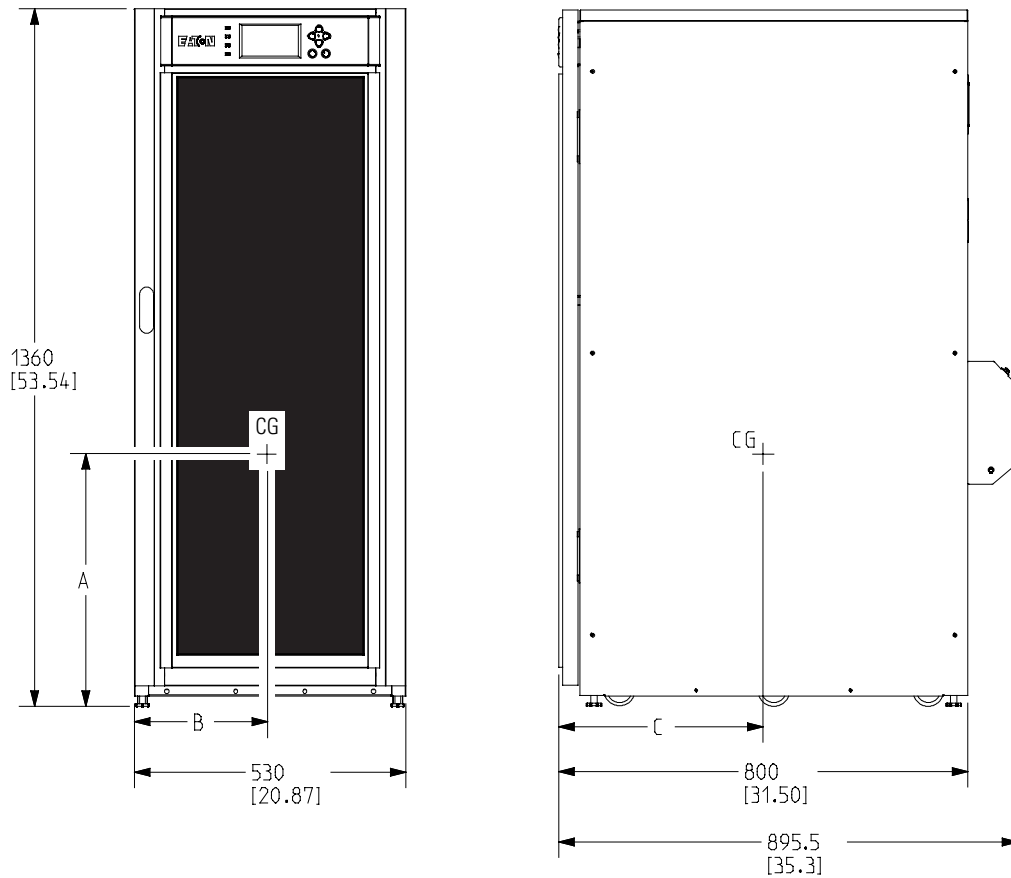

Dimensions are in millimeters [inches]

Weight and Center of Gravity, see [Figure 4](#).

Eaton 93E UPS	A	B	C	Weight kg (lb)
With Batteries (93E-20 – 4 strings)	517 [20.4]	259 [10.20]	399 [15.71]	377 (831) – Installed
With Batteries (93E-30/20 and 93E-30/30 – 6 strings)	477 [17.60]	259 [10.20]	399 [15.71]	476 (1049) – Installed
Without Batteries	657 [25.87]	249 [9.80]	399 [15.71]	261 (575) – Shipping

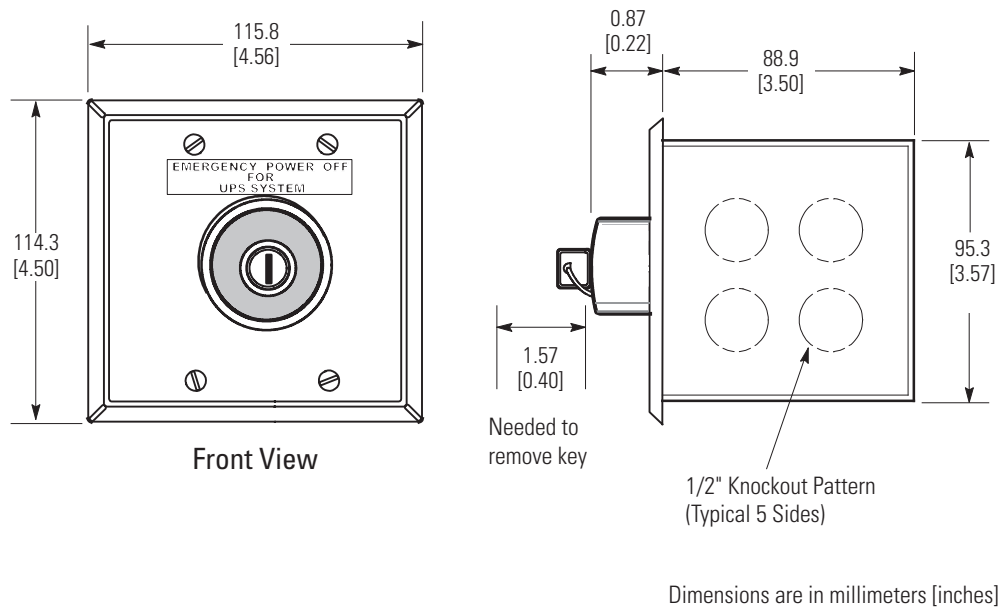
Figure 5. Remote EPO Switch Dimensions

3.2.2 UPS System Power Wiring Preparation

Read and understand the following notes while planning and performing the installation:

⚡ WARNING

As a result of the connected loads high leakage current is possible. Connection to earth ground is required for safety and proper product operation. Do not check UPS operation by any action that includes removal of the earth (ground) connection with loads attached.

- Refer to national and local electrical codes for acceptable external wiring practices.
- To allow for future kVA upgrades, consider installing a derated UPS using wiring and external overcurrent protection breakers sized for a fully rated UPS.
- For external wiring, use 90°C copper wire. Wire sizes listed in [Table 5](#) are for copper wiring only. If wire is run in an ambient temperature greater than 30°C, higher temperature wire and/or larger size wire may be necessary. Wire sizes are based on using the specified breakers.
- Wire ampacities are chosen from Table 310-16 of the National Electrical Code® (NEC®). Specification is for copper wire with a 90°C rating.
- If installing an external maintenance bypass, all feeds to the UPS including the Rectifier Input Breaker (RIB) (if installed) must have a service disconnect independent of the maintenance bypass power path. Most maintenance bypass solutions provide UPS input feeds derived from but isolated from the maintenance bypass power path. If the maintenance bypass solution being installed does not provide such functionality, DO NOT use a single feeder breaker to supply both the UPS and the maintenance bypass.
- Phase rotation must be clockwise starting with phase A (rotation A, B, C).

- The bypass feed into this equipment uses four wires. The rectifier feed into this equipment uses four wires. The phases must be symmetrical about ground (from a Wye source, phase rotation clockwise A, B, C) for proper equipment operation.
- Parallel UPS input wiring size requirements and output wiring size requirements from the UPSs to the Integrated Accessory Cabinet-Tie (IAC-T) or Integrated Accessory Cabinet-Tie and Bypass (IAC-TB) are the same as listed in [Table 5](#). Refer to the Eaton 93E Integrated Accessory Cabinet-Tie and Bypass Installation and Operation Manual listed in paragraph [1.7 For More Information](#) for additional IAC-T or IAC-TB wiring and termination requirements.

For external wiring requirements, including the minimum AWG size of external wiring, see [Table 5](#). Wire sizes listed are for copper wiring only. The number of neutral conductors listed are for single size neutral wiring. A 1.5x sized neutral can be supported by this product. Two terminal landings are provided to accommodate extra neutral wiring.

Table 5. Input/Output Ratings and External Wiring Requirements for the Eaton 93E–20, 93E–30/20, and 93E–30/30

	Units	Rating 50/60 Hz	
Basic Unit Rating	kVA	20	30
	kW	16	24
Input Voltage	Volts	208/220	208/220
Output Voltage	Volts	208/220	208/220
AC Input to UPS Rectifier (0.98 Minimum pF) Full load current plus battery recharge current (3) Phases, (1) Neutral, (1) Ground	Amps	64/60	96/91
Minimum Conductor Size (Phase A, B, and C) Number per Phase	A	AWG or kcmil (each)	2 (1)
	–	AWG or kcmil (each)	1/0 (1)
	–	AWG or kcmil (each)	6 (1)
Minimum Conductor Size (Neutral) Number per Phase	–	AWG or kcmil (each)	2 (1)
Minimum Conductor Size (Ground) Number per Phase	–	AWG or kcmil (each)	6 (1)
AC Input to UPS Bypass (Five Wire, Dual-Feed) Full Load Current (3) Phases, (1) Neutral, (1) Ground	Amps	56/52	83/79
Minimum Conductor Size (Phase A, B, and C) Number per Phase	B	AWG or kcmil (each)	2 (1)
	–	AWG or kcmil (each)	1/0 (1)
	–	AWG or kcmil (each)	6 (1)
Minimum Conductor Size (Neutral) Number per Phase	–	AWG or kcmil (each)	2 (1)
Minimum Conductor Size (Ground) Number per Phase	–	AWG or kcmil (each)	6 (1)
DC Input from External Battery (1) Positive, (1) Negative, (1) Ground	Total Amps	79	124
Minimum Conductor Size (Phase Positive and Negative) Number per Pole	C	AWG or kcmil (each)	2 (1)
	–	AWG or kcmil (each)	1/0 (1)
Minimum Conductor Size (Ground)	–	AWG or kcmil (each)	6 (1)

Table 5. Input/Output Ratings and External Wiring Requirements for the Eaton 93E–20, 93E–30/20, and 93E–30/30 (Continued)

Number per Phase	(each)	(1)	(1)
AC Output to Critical Load (Five Wire)	Amps	56/52	83/79
Full Load Current (3) Phases, (1) Neutral, (1) Ground	D		
Minimum Conductor Size (Phase A, B, and C) Number per Phase	AWG or kcmil (each)	2 (1)	1/0 (1)
Minimum Conductor Size (Neutral) Number per Phase	– AWG or kcmil (each)	2 (1)	1/0 (1)
Minimum Conductor Size (Ground) Number per Phase	– AWG or kcmil (each)	6 (1)	6 (1)

NOTE Callout letters **A**, **B**, and **D** map to [Figure 35](#). Callout letters **A**, **B**, **C**, and **D** map to [Figure 36](#) and [Figure 37](#).



IMPORTANT

If a 4-pole Automatic Transfer Switch (ATS) is used to connect the UPS to a generator or alternative input source, it may interrupt the UPS input neutral during its transition between sources. This UPS should always have an input source neutral connected at the bypass input terminals. This neutral must be continuous and uninterrupted; even if there are no phase-to-neutral loads connected to the UPS output. If the UPS is fed from a 4-pole ATS that interrupts the neutral, a delta-to-wye isolation transformer, with its secondary neutral bonded to ground, must be placed in line with the bypass input of the UPS. This will provide an uninterrupted neutral to the UPS, regardless of the position of the ATS neutral contact.

Note: if an overlapping neutral or make-before-break ATS switch is used, the neutrals must overlap for a minimum of 50 msec during the transition. In these cases, a transformer is not needed.

The power wiring terminals are pressure terminations, UL and CSA rated at 90°C. See [Table 6](#) for external power cable terminations.

[Figure 13](#) and [Figure 14](#) show the location of the UPS power cable terminals.

Table 6. UPS External Power Cable Terminations for the Eaton 93E–20, 93E–30/20, and 93E–30/30

Terminal Function	Terminal	Function	Number and Size of Pressure Termination AWG or kcmil	Tightening Torque Nm (lb in)	Screw Size and Type
AC Input to UPS Rectifier	L1	Phase A	1 – #14-2/0	12.4 (110)	3/16 in. Hex
	L2	Phase B	1 – #14-2/0	12.4 (110)	3/16 in. Hex
	L3	Phase C	1 – #14-2/0	12.4 (110)	3/16 in. Hex
	N	Neutral	2 – #14-2/0	12.4 (110)	3/16 in. Hex
AC Input to Bypass	L1	Phase A	1 – #14-2/0	12.4 (110)	3/16 in. Hex
	L2	Phase B	1 – #14-2/0	12.4 (110)	3/16 in. Hex
	L3	Phase C	1 – #14-2/0	12.4 (110)	3/16 in. Hex
	N	Neutral	2 – #14-2/0	12.4 (110)	3/16 in. Hex

Table 6. UPS External Power Cable Terminations for the Eaton 93E–20, 93E–30/20, and 93E–30/30 (Continued)

Terminal Function	Terminal	Function	Number and Size of Pressure Termination AWG or kcmil	Tightening Torque Nm (lb in)	Screw Size and Type
AC Output to Critical Load	L1	Phase A	1 – #14-2/0	12.4 (110)	3/16 in. Hex
	L2	Phase B	1 – #14-2/0	12.4 (110)	3/16 in. Hex
	L3	Phase C	1 – #14-2/0	12.4 (110)	3/16 in. Hex
	N	Neutral	2 – #14-2/0	12.4 (110)	3/16 in. Hex
DC Input from External Battery	+	Battery (+)	1 – #6-350	31.1 (275)	5/16 in. Hex
	–	Battery (-)	1 – #6-350	31.1 (275)	5/16 in. Hex
Customer Ground	Ground	Ground	4 – #14-1/0	5.1 (45)	Slotted

NOTE Customer ground, sized in accordance with NEC Table 250.122, can be run in any conduit listed in [Table 7](#).

Conduit sizes were chosen from NEC Table 4, Electrical Metallic Tubing (EMT). See [Table 7](#) for conduit requirements.

Per NEC article 300, 3(B)(1), all three-phase conductors must be run in the same conduit. Neutral and ground must be run in the same conduit as the phase conductors.

Conduit is sized to accommodate one neutral conductor the same size as the phase conductor and one ground conductor sized in accordance with NEC Table 250.122. This product can support a 1.5x sized neutral. If two neutral conductors or an oversized neutral conductor are to be installed, verify the size of the conduit needed to accommodate the extra wire or size and use that conduit size in place of the conduit size listed in [Table 7](#).

Conduit sizes listed are for copper wiring only.

Table 7. Power Cable Conduit Requirements

UPS Model	Voltage	Terminal	Number of Wires in Conduit	Minimum Conduit Trade Size	Number of Conduits
Eaton 93E–20 Eaton 93E–30/20	208/220 Vac	AC Input to UPS Rectifier (A, B, C, Neutral, Ground)	5	1-1/2	1
		AC Input to Bypass and Output (Five Wire) (A, B, C, Neutral, Ground)	5	1-1/2	1
	DC	Battery (Positive, Negative, Ground)	3	1-1/2	1
Eaton 93E–30/30	208/220 Vac	AC Input to UPS Rectifier (A, B, C, Neutral, Ground)	5	2	1
		AC Input to Bypass and Output (Five Wire) (A, B, C, Neutral, Ground)	5	2	1
	DC	Battery (Positive, Negative, Ground)	3	2	1

External overcurrent protection and disconnect are not provided by this product, but are required by codes. Refer to [Table 5](#) for wiring requirements. If an output lockable disconnect is required, it is to be supplied by the customer.

[Table 8](#) lists the recommended rating for input circuit breakers.

Table 8. Recommended Input Circuit Breaker Ratings

UPS Model	Input Rating	
	Load Rating	208/220V
Eaton 93E-20	80% Rated	100A
Eaton 93E-30/20	100% Rated	80A
Eaton 93E-30/30	80% Rated	125A
	100% Rated	100A

 **CAUTION**

To reduce the risk of fire, connect only to a circuit provided with maximum input circuit breaker current ratings from [Table 8](#) in accordance with the NEC, ANSI/NFPA 70.

The line-to-line unbalanced output capability of the UPS is limited only by the full load per phase current values for AC output to critical load shown in [Table 5](#). The recommended line-to-line load unbalance is 50% or less.

Bypass and output overcurrent protection and bypass and output disconnect switches are to be supplied by the customer. [Table 9](#) lists the recommended rating for bypass and output circuit breakers.

Table 9. Recommended Bypass and Output Circuit Breaker Ratings

UPS Model	Output Rating	
	Load Rating	208/220V
Eaton 93E-20	80% Rated	100A
Eaton 93E-30/20	100% Rated	80A
Eaton 93E-30/30	80% Rated	125A
	100% Rated	100A

Battery voltage is computed at 2 volts per cell as defined by Article 480 of the NEC. Rated battery current is computed based on 2 volts per cell.

3.2.3 UPS System Interface Wiring Preparation

Control wiring for features and options should be connected at the customer interface terminal blocks located inside the UPS.

 **WARNING**

Do not directly connect relay contacts to the mains related circuits. Reinforced insulation to the mains is required.

Read and understand the following notes while planning and performing the installation:

- Use Class 1 wiring methods (as defined by the NEC) for interface wiring from 30V to 600V. The wire should be rated for 600V, 1A minimum. 12 AWG maximum wire size.
- Use Class 2 wiring methods (as defined by the NEC) for interface wiring up to 30V. The wire should be rated for 24V, 1A minimum.
- Because of the REPO and building alarm wiring route in the UPS cabinet, the wire should be rated for a minimum of 300V.
- Use twisted-pair wires for each input and return or common.
- All interface wiring and conduit is to be supplied by the customer.
- When installing external interface wiring between a REPO or building alarm and the UPS interface terminals, conduit must be installed between each device and the UPS cabinet.
- Interface wiring can be installed using conduit through the bottom of power terminal cover base or by routing wiring through the power terminal cover base wiring channels between the UPS and SIAC-B, IAC-T, or IAC-TB.
- If using the power terminal wiring channel, keep interface wiring separate from power wiring or use shielded wire.
- If using conduit, install the interface wiring in separate conduit from the power wiring.
- All building alarm inputs require an isolated normally-open contact or switch (rated at 24 Vdc, 20 mA minimum) connected between the alarm input and common terminal. All control wiring and switch contacts are customer-supplied.
- LAN and telephone drops for use with Mini-Slot connectivity cards must be supplied by the customer.
- The REPO feature opens all switchgear in the UPS cabinet and isolates power from your critical load. Local electrical codes may also require tripping upstream protective devices to the UPS.
- The REPO switch must be a latching-type switch not tied to any other circuits.
- A jumper wire must be connected between pins 3 and 4 on the REPO terminal block if using a normally-closed REPO switch.
- REPO wiring should be a minimum of 22 AWG and a maximum of 14 AWG.
- The REPO switch wiring must be in accordance with NEC Article 725 Class 2 requirements.
- The maximum distance between the REPO and the UPS cannot exceed 150 meters (500 feet).

3.3 Battery Type

The battery types listed in [Table 10](#) are supplied in the UPS Cabinet and external Battery Cabinet. When purchasing UPS Cabinet or external Battery Cabinet without batteries, only the following types are recommended. Use of any other battery type inside Eaton cabinets will void the product warranty. When replacing batteries use the same manufacturer and part number originally supplied with the unit to ensure correct harness fit and terminal landing.

Table 10. Battery Type

Battery Manufacturer	CSB Battery Technologies Inc.	G.S. Yuasa
Battery Model	HRL1234WF2FR	REW45-12FR
Battery Quantity 93E–20	72	72
Battery Quantity 93E–30/20	108	108
Battery Quantity 93E–30/30	108	108

3.4 Inspecting and Unpacking the UPS Cabinets

The cabinet is shipped bolted to a wooden pallet and protected with an outer wood container (see [Figure 6](#)).

 **WARNING**

The UPS cabinet is heavy (see [Table 3](#)). If unpacking and unloading instructions are not closely followed, the cabinet may tip and cause serious injury.

1. Carefully inspect the outer packaging for evidence of damage during transit.

 **CAUTION**

Do not install a damaged cabinet. Report any damage to the carrier and contact an Eaton service representative immediately.

-
-  **NOTE** For the following step, verify that the forklift or pallet jack is rated to handle the weight of the cabinet (see [Table 3](#) for cabinet weight).
-

2. Use a forklift or pallet jack to move the packaged cabinet to the installation site, or as close as possible, before unpacking. If possible, move the cabinets using the pallet. Insert the forklift or pallet jack forks between the supports on the bottom of the pallet (see [Figure 4](#) for the UPS cabinet center of gravity measurements).

 **CAUTION**

Do not tilt the UPS cabinets more than 10° from vertical or the cabinets may tip over.

3. Set the pallet on a firm, level surface, allowing a minimum clearance of 3m (10 ft) on each side for removing the cabinet from the pallet.
4. Remove the protective wood container from the cabinet:

-
-  **NOTE** For the following steps, use pincer type pliers or a large flat blade screw driver to straighten the securing tabs.
-

- a. Straighten the tabs securing the top panel of the wooden container to the side panels of the container.
 - b. Remove the top panel and retain for later use as a ramp in unloading the cabinet from the pallet.
 - c. Straighten the tabs securing the side panels of the container to the front and back panels of the container.
 - d. Remove the side panels.
 - e. Straighten the tabs securing the front and back panels of the container to the bottom of the container.
 - f. Remove the front and back panels.
5. Remove the inner protective packaging. Retain the parts kit box, ramp brackets, and ramp extension packed at the top of the cabinet.
 6. Recycle the remainder of the outer shipping container and the inner protective packaging in a responsible manner.
 7. Inspect the contents for any evidence of physical damage, and compare each item with the Bill of Lading. If damage has occurred or shortages are evident, contact an Eaton service representative immediately to determine the extent of the damage and its impact on further installation.

i **NOTE** While waiting for installation, protect the unpacked cabinet from moisture, dust, and other harmful contaminants. Failure to store and protect the UPS properly may void your warranty.

Figure 6. UPS Cabinet as Shipped on Pallet (wood container removed)

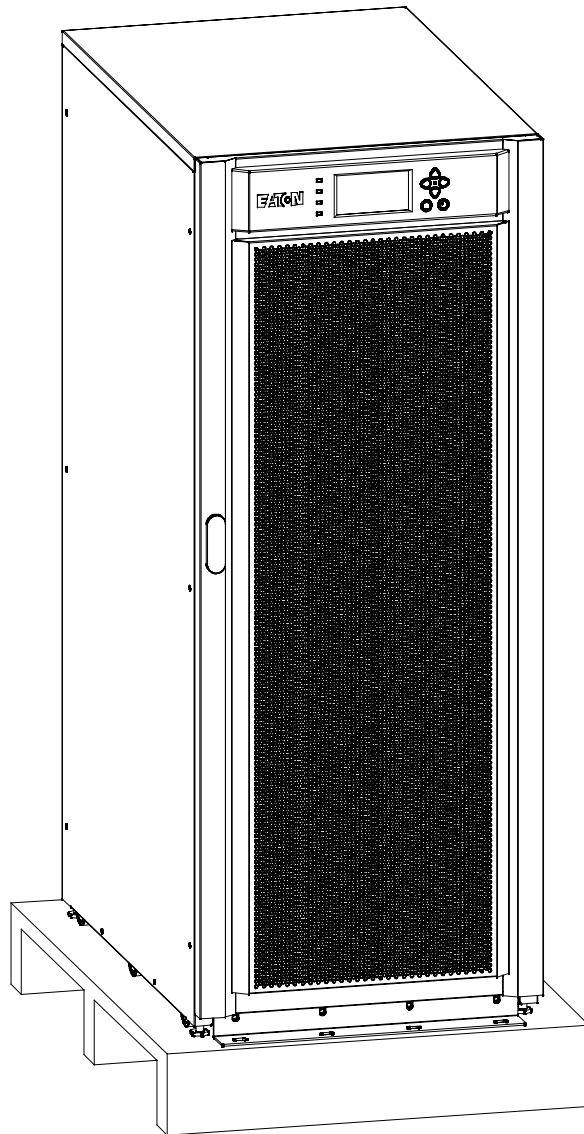

Chapter 4 UPS System Installation

4.1 Preliminary Installation Information

 **WARNING**

Installation should be performed only by qualified personnel.

Refer to the following while installing the UPS system:

- [Chapter 3 UPS Installation Plan and Unpacking](#) for cabinet dimensions, equipment weight, wiring and terminal data, and installation notes.
- Do not tilt the cabinets more than $\pm 10^\circ$ during installation.
- If perforated floor tiles are required for ventilation, place them in front of the UPS.

4.2 Unloading the UPS Cabinet from the Pallet

The UPS Cabinet is bolted to a wooden pallet supported by wood skids. To remove the pallet:

 **WARNING**

The UPS cabinet is heavy (see [Table 3](#)). If unpacking and unloading instructions are not closely followed, the cabinet may tip and cause serious injury.

 **CAUTION**

- Do not tilt cabinet more than 10° from vertical.
 - Lift the cabinets only with a forklift or damage may occur.
-

**NOTE**

For the following steps, verify that the forklift or pallet jack is rated to handle the weight of the cabinet (see [Table 3](#) for cabinet weight)

1. If not already accomplished, use a forklift or pallet jack to move the UPS cabinet to the installation area, or as close as possible, before unloading from the pallet. Insert the forklift or pallet jack forks between the supports on the bottom of the pallet (see [Figure 4](#) for the UPS cabinet center of gravity measurements).
2. Remove four bolts securing the front shipping bracket to the cabinet and four bolts securing the bracket to the pallet (see [Figure 7](#)). Remove the front shipping bracket. If installing the cabinet permanently, retain the shipping bracket and securing hardware for later use.
3. Attach the ramp to the front of the pallet (see [Figure 8](#)):
 - a. Locate the ramp (top panel from wood container), ramp extension, and ramp brackets with M10 bolts.
 - b. Place the ramp against the front of the pallet
 - c. Secure the ramp to pallet using the supplied ramp brackets and M10 bolts. Insert the lip on the brackets into the slots at the top of the ramp. Use the existing holes in the pallet to secure the ramp brackets.
 - d. Attach the ramp extension to the front of the ramp by inserting the tabs on the extension into the slots at the bottom of the ramp.
4. If the leveling feet are not fully retracted, turn the leveling feet until they are retracted.

Figure 7. Removing the Front Shipping Bracket

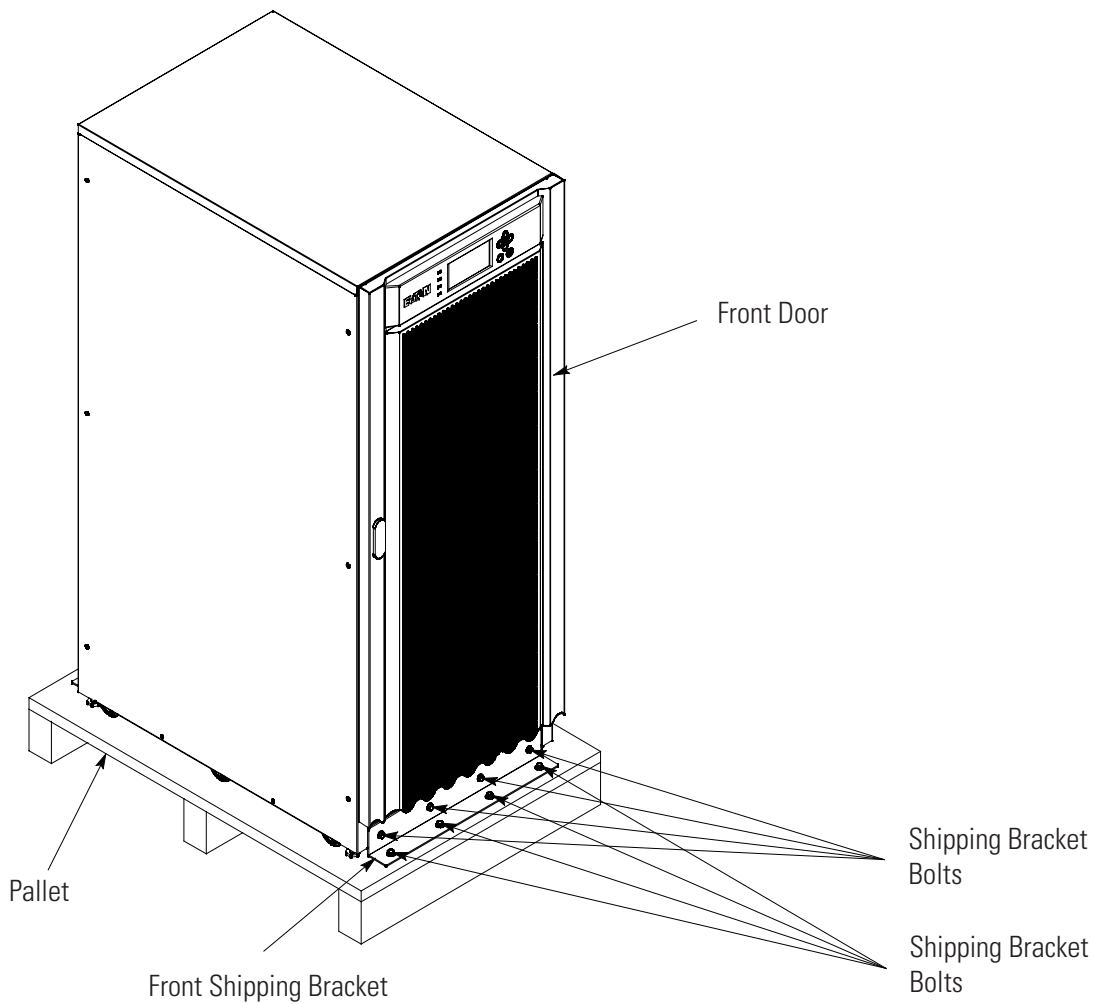

5. Remove four bolts securing the rear shipping bracket to the cabinet and four bolts securing the bracket to the pallet (see [Figure 9](#)). Remove the rear shipping bracket. If installing the cabinet permanently, retain the shipping bracket and securing hardware for later use.

⚡ WARNING

Do not stand directly in front of the pallet while unloading the cabinet. If unloading instructions are not closely followed, the cabinet may cause serious injury.

6. Slowly roll the cabinet toward the front of the pallet. Continue rolling the cabinet down the ramp until the cabinet is clear of the ramp (see [Figure 10](#)).
7. Roll the cabinet to the final installation location.
8. If installing the cabinet permanently, retain the shipping brackets and hardware; otherwise, recycle the pallet, ramp, and shipping brackets in a responsible manner.

9. Lower the UPS cabinet feet and using a level, adjust the cabinet height accordingly until the cabinet is level.
10. If permanently mounting the system, proceed to [Step 11](#); otherwise, continue to [Step 13](#).
11. Using the retained hardware, reinstall the shipping brackets removed in [Step 2](#) and [Step 5](#) to the front and rear of the UPS cabinet with the angle facing outward (see [Figure 7](#) and [Figure 9](#)).
12. Secure the cabinet to the floor with customer-supplied hardware.
13. Proceed to paragraph [4.3 Installing Power Terminal Cover Base](#).

Figure 8. Attaching the Ramp to the Pallet

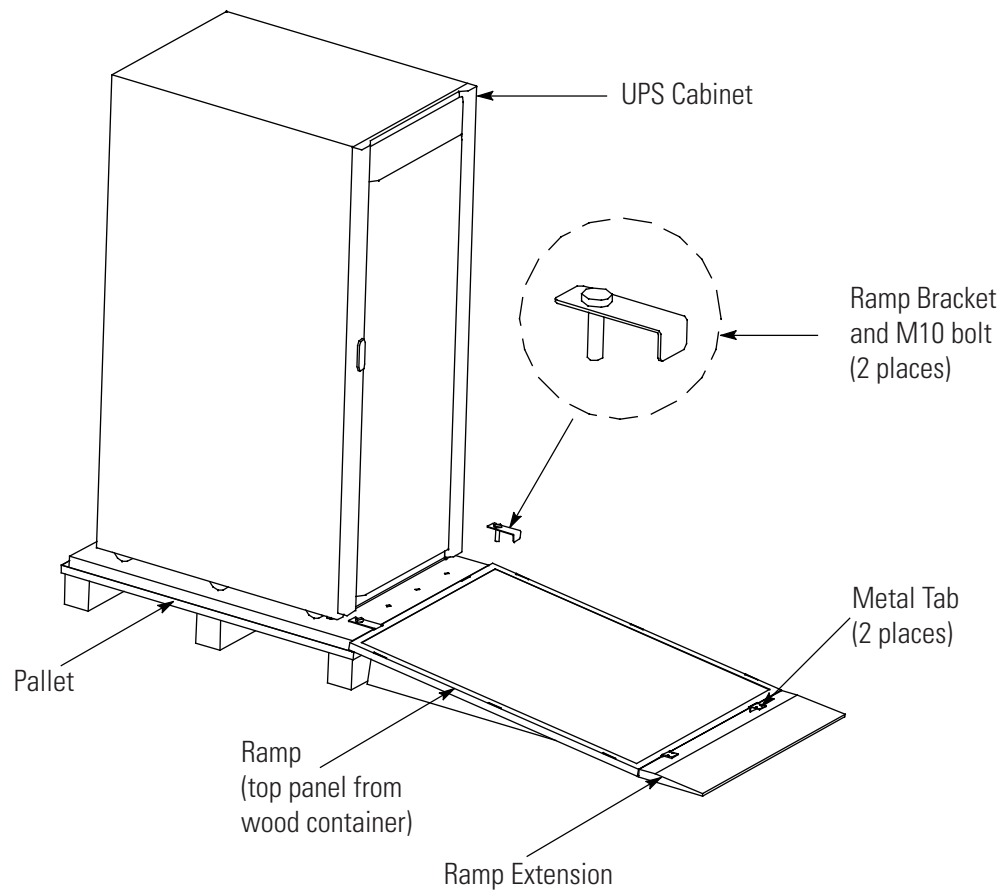

Figure 9. Removing the Rear Shipping Bracket

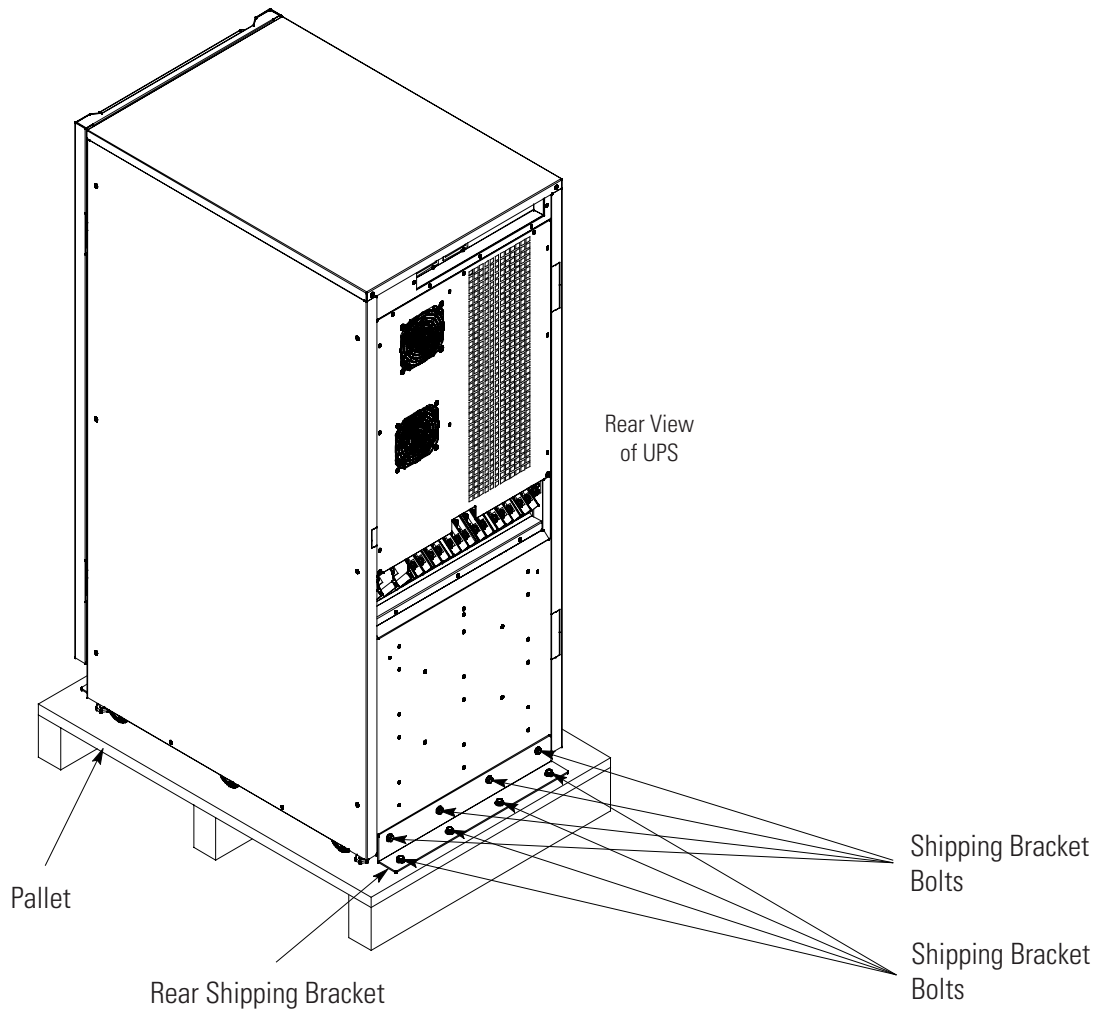
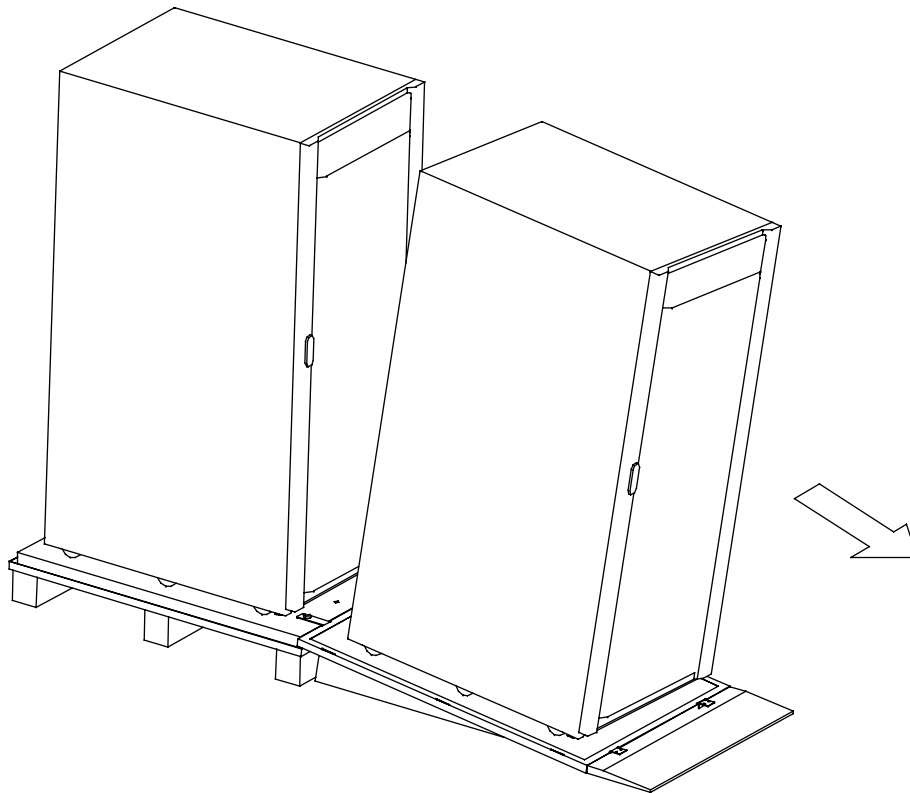

Figure 10. Rolling the Cabinet Down the Ramp

4.3 Installing Power Terminal Cover Base



NOTE

Wiring can be installed between the UPS and accessory cabinets by using conduit or by routing wiring through the power terminal cover base wiring channels.

To install the Power Terminal Cover Base:

1. Locate the terminal cover base (see [Figure 11](#)) from the parts kit.
2. If installing wiring using conduit, proceed to [Step 3](#); otherwise, proceed to [Step 4](#).
3. Punch or drill holes in the bottom of the power terminal cover base (see [Figure 11](#) and [Figure 12](#)) for the AC input, output, bypass, DC input, REPO conduit as required.
4. Using the hardware provided, install the terminal cover base to the back panel of the UPS using the existing cabinet screw holes (see [Figure 12](#)).
5. Proceed to paragraph [4.4 External Battery Cabinet Installation](#).

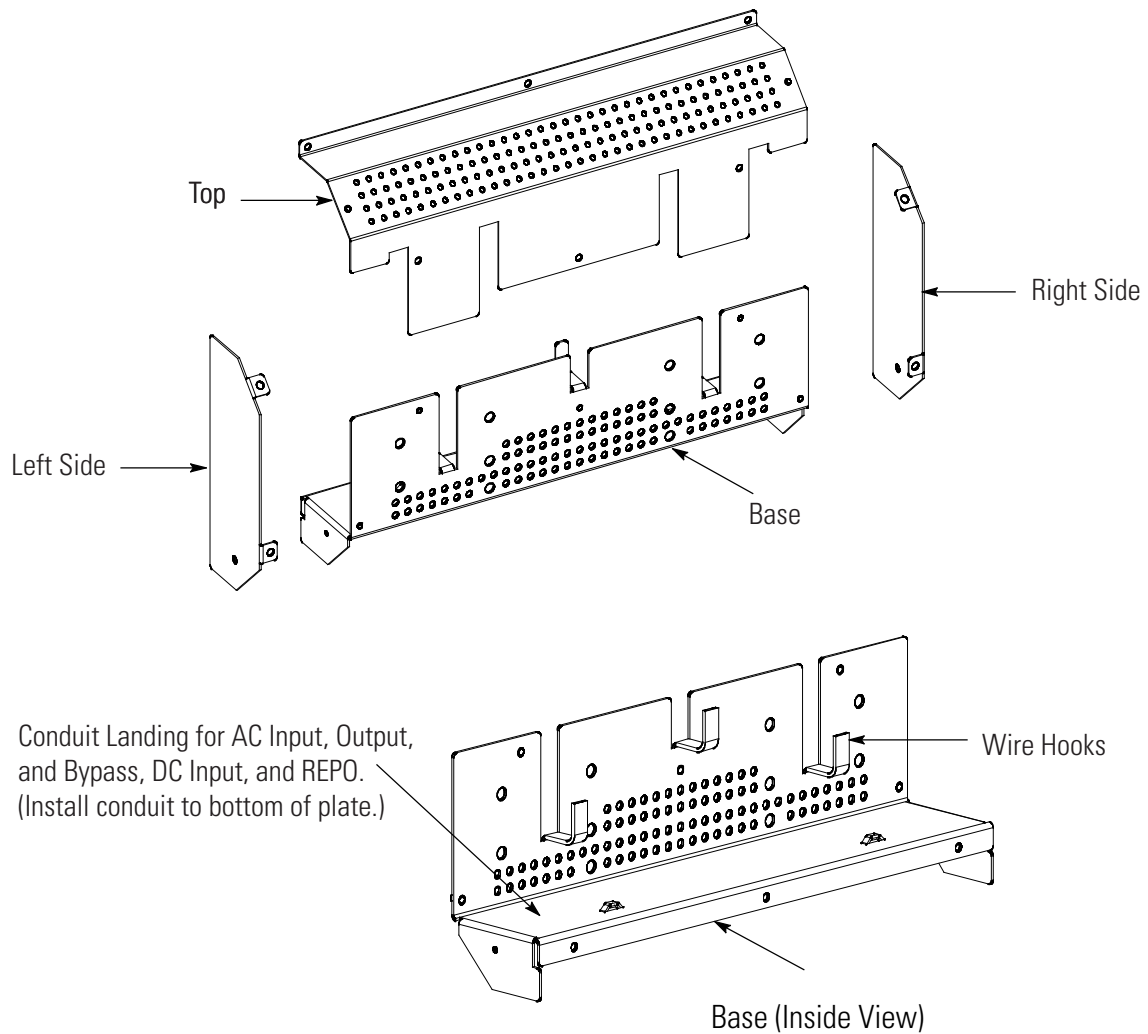
Figure 11. UPS Power Terminal Cover Parts

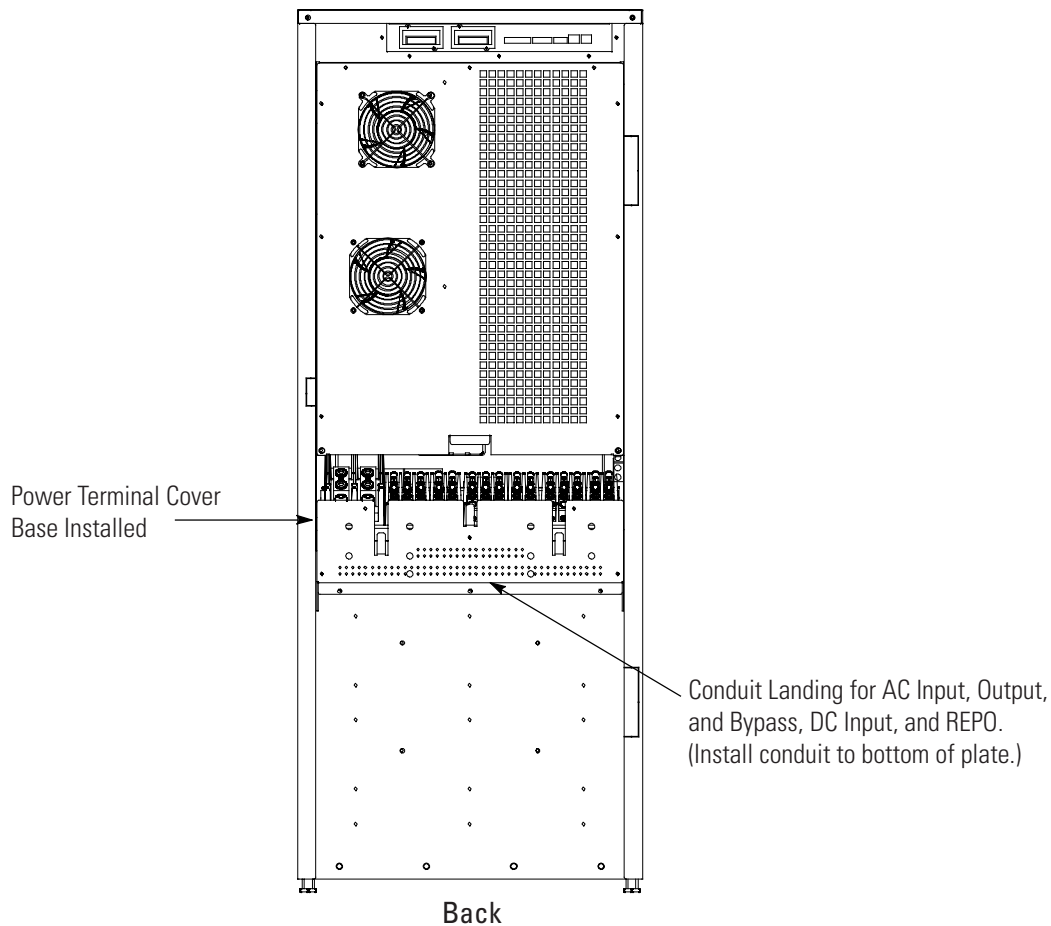

NOTE Do not install the Power Terminal Cover Left and/or Right Side covers if wiring adjacent ancillary cabinets (such as an EBC or IAC) using the power terminal base wiring channel.

Figure 12. UPS Power Terminal Cover Base Installation and Conduit Landing Wire Entry Locations

4.4 External Battery Cabinet Installation

If installing External Battery Cabinets (EBCs), refer to the Eaton 93E External Battery Cabinet Installation Manual listed in paragraph [1.7 For More Information](#) for installation instructions.

After the EBC is installed, proceed to paragraph [4.5 Integrated Transformer Cabinet Installation](#) if installing an Integrated Transformer Cabinet (ITC), to paragraph [4.6 Sidecar Integrated Accessory Cabinet-Bypass](#) if installing a Sidecar Integrated Accessory Cabinet-Bypass (SIAC-B), to paragraph [4.7 Integrated Accessory Cabinet-Tie](#) if installing a Integrated Accessory Cabinet-Tie (IAC-T), to paragraph [4.8 Integrated Accessory Cabinet-Tie and Bypass](#) if installing a Integrated Accessory Cabinet-Tie and Bypass (IAC-TB), or to paragraph [4.9 Integrated Accessory Cabinet-Distribution](#) if installing an Integrated Accessory Cabinet-Distribution (IAC-D); otherwise, proceed to paragraph [4.10 External Power Wiring Installation](#) to complete the wiring of the UPS.

4.5 Integrated Transformer Cabinet Installation

If installing an ITC, refer to the Eaton 93E Integrated Transformer Cabinet Installation Manual listed in paragraph [1.7 For More Information](#) for installation instructions.

After the ITC is installed, proceed to paragraph [4.6 Sidecar Integrated Accessory Cabinet-Bypass](#) if installing an Sidecar Integrated Accessory Cabinet-Bypass (SIAC-B), to paragraph [4.7 Integrated Accessory Cabinet-Tie](#) if

installing an IAC-B, or to paragraph [4.9 Integrated Accessory Cabinet-Distribution](#) if installing an IAC-D; otherwise, proceed to paragraph [4.10 External Power Wiring Installation](#) to complete the wiring of the UPS.

4.6 Sidecar Integrated Accessory Cabinet-Bypass

If installing an SIAC-B, refer to the Eaton 93E Sidecar Integrated Accessory Cabinet-Bypass Installation and Operation Manual listed in paragraph [1.7 For More Information](#) for installation instructions.

After the SIAC-B is installed, proceed to paragraph [4.9 Integrated Accessory Cabinet-Distribution](#) if installing Integrated Accessory Cabinet-Distribution; otherwise, proceed to paragraph [4.10 External Power Wiring Installation](#) to complete the wiring of the UPS.

4.7 Integrated Accessory Cabinet-Tie

If installing an IAC-T, refer to the Eaton 93E Integrated Accessory Cabinet-Tie and Bypass Installation and Operation Manual listed in paragraph [1.7 For More Information](#) for installation instructions.

After the IAC-T is installed, proceed to paragraph [4.9 Integrated Accessory Cabinet-Distribution](#) if installing Integrated Accessory Cabinet-Distribution; otherwise, proceed to paragraph [4.10 External Power Wiring Installation](#) to complete the wiring of the UPS.

4.8 Integrated Accessory Cabinet-Tie and Bypass

If installing an IAC-TB, refer to the Eaton 93E Integrated Accessory Cabinet-Tie and Bypass Installation and Operation Manual listed in paragraph [1.7 For More Information](#) for installation instructions.

After the IAC-TB is installed, proceed to paragraph [4.9 Integrated Accessory Cabinet-Distribution](#) if installing Integrated Accessory Cabinet-Distribution; otherwise, proceed to paragraph [4.10 External Power Wiring Installation](#) to complete the wiring of the UPS.

4.9 Integrated Accessory Cabinet-Distribution

If installing IAC-D, refer to the Eaton 93E Integrated Accessory Cabinet-Distribution Installation and Operation Manual listed in paragraph [1.7 For More Information](#) for installation instructions.

After the IAC-D is installed, proceed to paragraph [4.10 External Power Wiring Installation](#) to complete the wiring of the UPS.

4.10 External Power Wiring Installation



NOTE

Without accessory cabinets, conduit and wiring enter from the bottom of the UPS conduit landing plate. With accessory cabinets, wiring can be installed between the UPS and accessory cabinets by using conduit or by routing wiring through the power terminal cover base wiring channels.

To install wiring:

1. Install conduit for UPS input and output wiring.
 2. Route the wiring to the UPS terminal blocks on the back of the UPS. See [Figure 12](#) for wiring access information and [Figure 13](#) for terminal locations.
-



WARNING

As a result of the connected loads high leakage current is possible. Connection to earth ground is required for safety and proper product operation. Do not check UPS operation by any action that includes removal of the earth (ground) connection with loads attached.

3. Ground the UPS according to local and/or national electrical wiring codes by routing and connecting the ground wire to the input ground lug. See [Figure 13](#) for UPS terminal locations.
For a detailed view of the UPS ground terminals, see [Figure 14](#).
4. Connect phase A, B, C, and Neutral (single-feed only) rectifier input power wiring from the utility source to the rectifier input and neutral terminals. See paragraph [3.2.2 UPS System Power Wiring Preparation](#) for wiring and termination requirements.
For a detailed view of the UPS terminal block, see [Figure 14](#).
5. If wiring a dual-feed system, proceed to [Step 6](#); otherwise, proceed to [Step 7](#).
6. Connect phase A, B, and C, and Neutral bypass input power wiring from the utility source to the bypass input terminals and neutral terminals. See paragraph [3.2.2 UPS System Power Wiring Preparation](#) for wiring and termination requirements.
For a detailed view of the UPS terminal block, see [Figure 14](#).
7. Connect phase A, B, and C, and Neutral (if required) power wiring from output terminals and neutral terminals to the critical load. See paragraph [3.2.2 UPS System Power Wiring Preparation](#) for wiring and termination requirements.
For a detailed view of the UPS terminal block, see [Figure 14](#).
8. If wiring interface connections, proceed to paragraph [4.11 Installing Interface Wiring and Connections](#); otherwise, proceed to [Step 9](#).
9. Install the power terminal cover top using the provided hardware (see [Figure 15](#)).

**NOTE**

Do not install the Power Terminal Cover Left and/or Right Side covers if wiring adjacent ancillary cabinets (such as an EBC or IAC) using the power terminal base wiring channel.

10. Install the power terminal cover right and left sides using the provided hardware.
11. Proceed to paragraph [4.13 Connecting Internal Battery Strings](#).

Figure 13. Power Terminal Locations

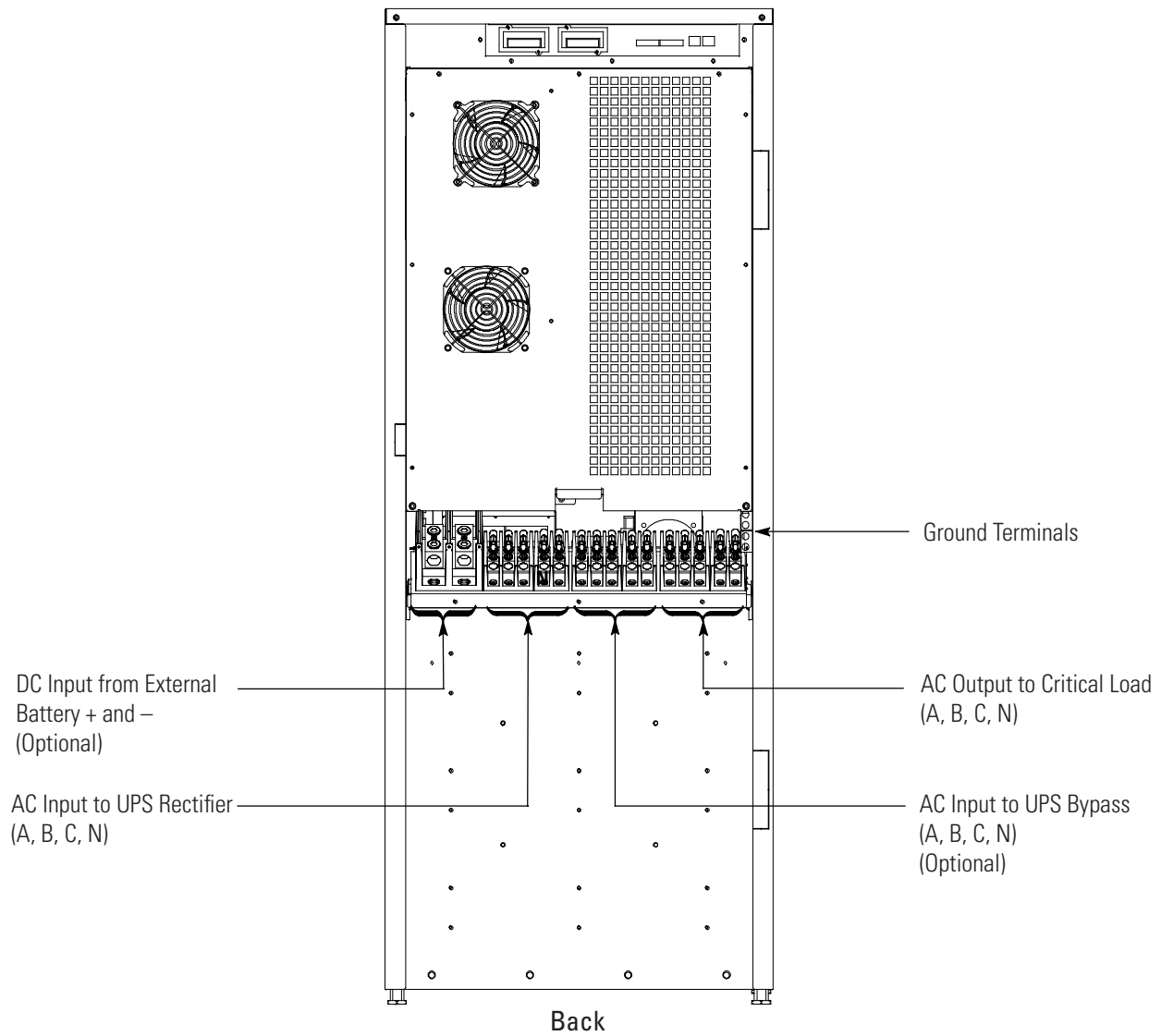

Figure 14. Power Terminal Detail

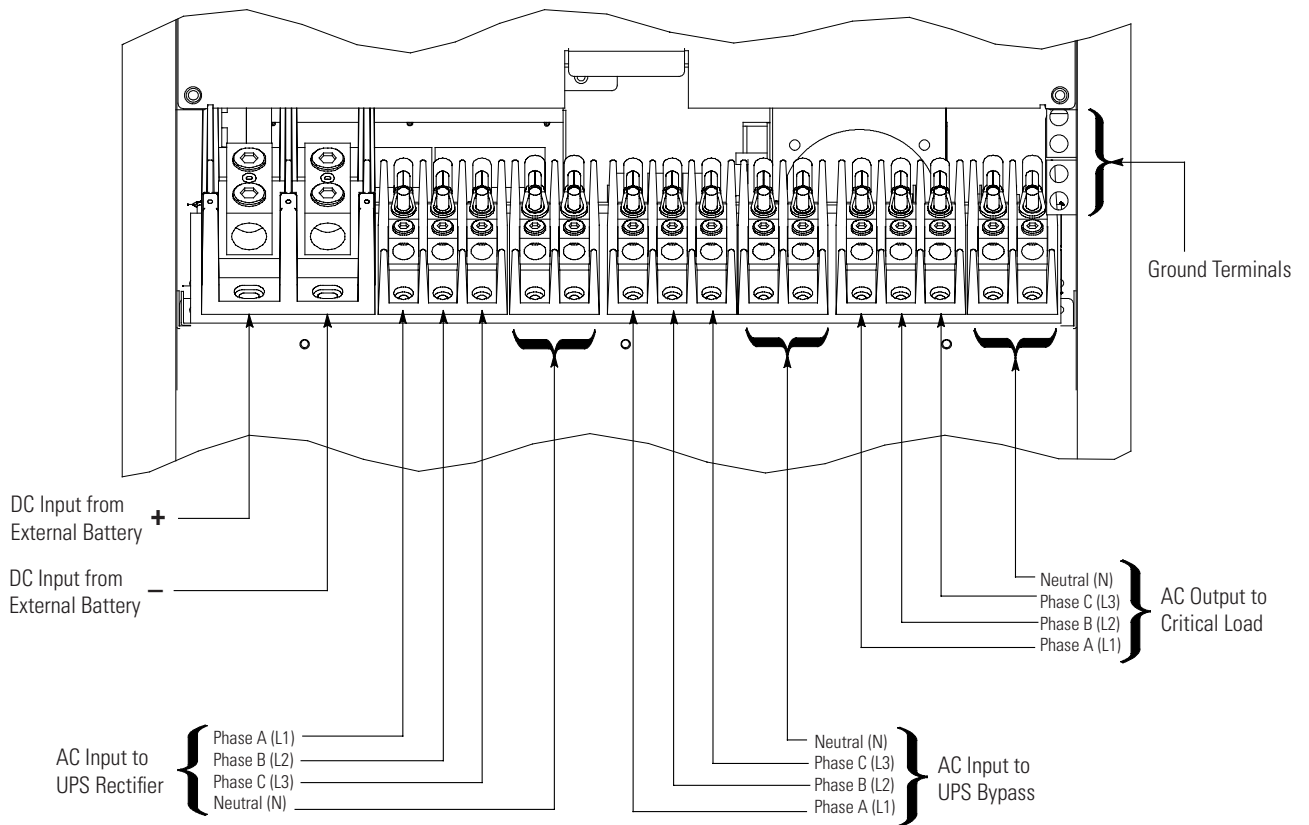
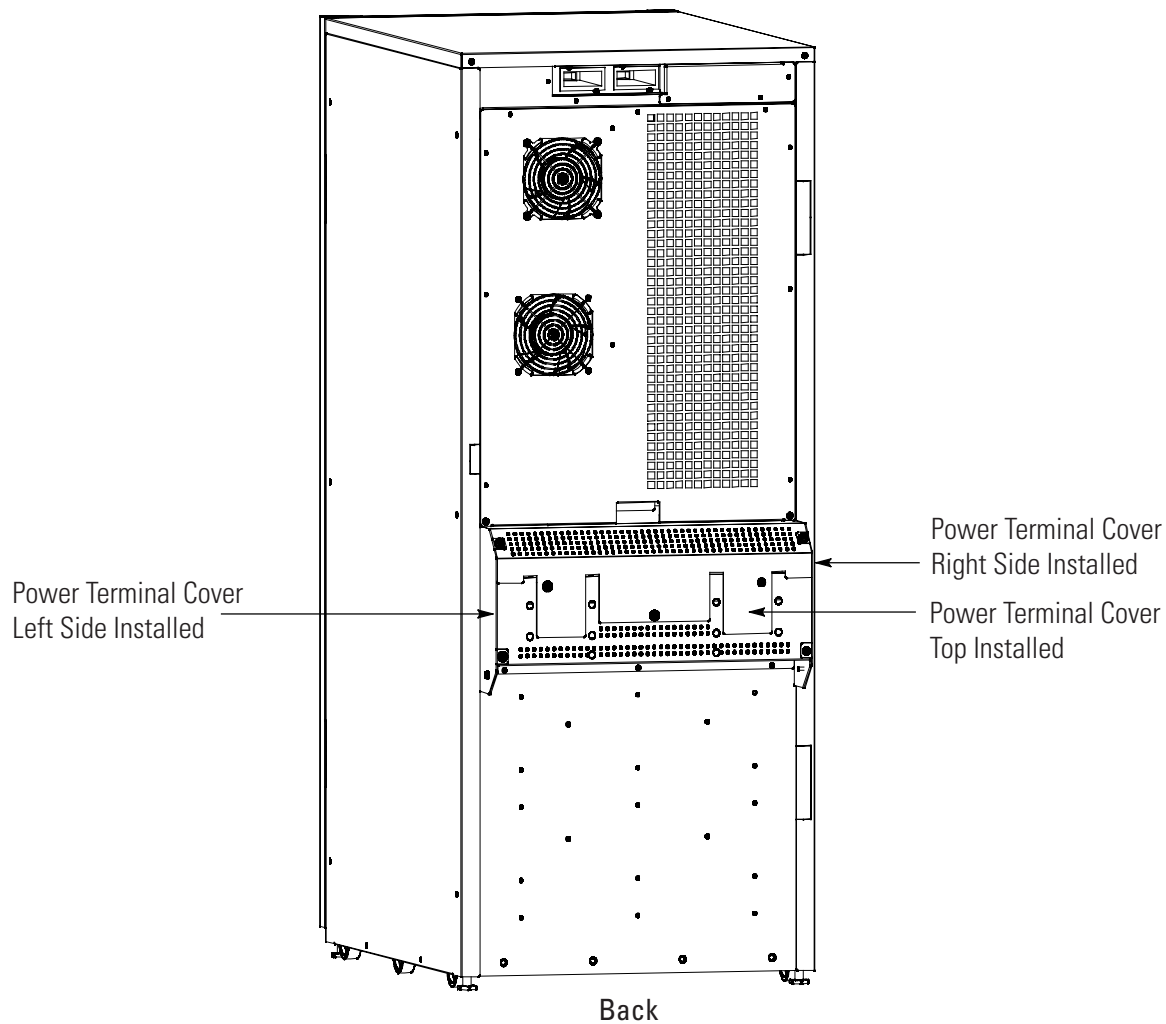

Figure 15. Power Terminal Cover Top Installation



NOTE Do not install the Power Terminal Cover Left and/or Right Side covers if wiring adjacent ancillary cabinets (such as an EBC or IAC) using the power terminal base wiring channel.

4.11 Installing Interface Wiring and Connections

4.11.1 Installing Building Alarm Wiring and Connections

To install wiring:

1. Verify the UPS system is turned off and all power sources are removed. See [Chapter 7 UPS Operating Instructions](#) for shutdown instructions.
2. To locate the appropriate terminals and review the wiring and termination requirements, see paragraph [3.2.3 UPS System Interface Wiring Preparation](#), [Table 11](#), [Figure 16](#), [Figure 17](#), and [Figure 18](#).

Figure 16. Interface Terminal Locations

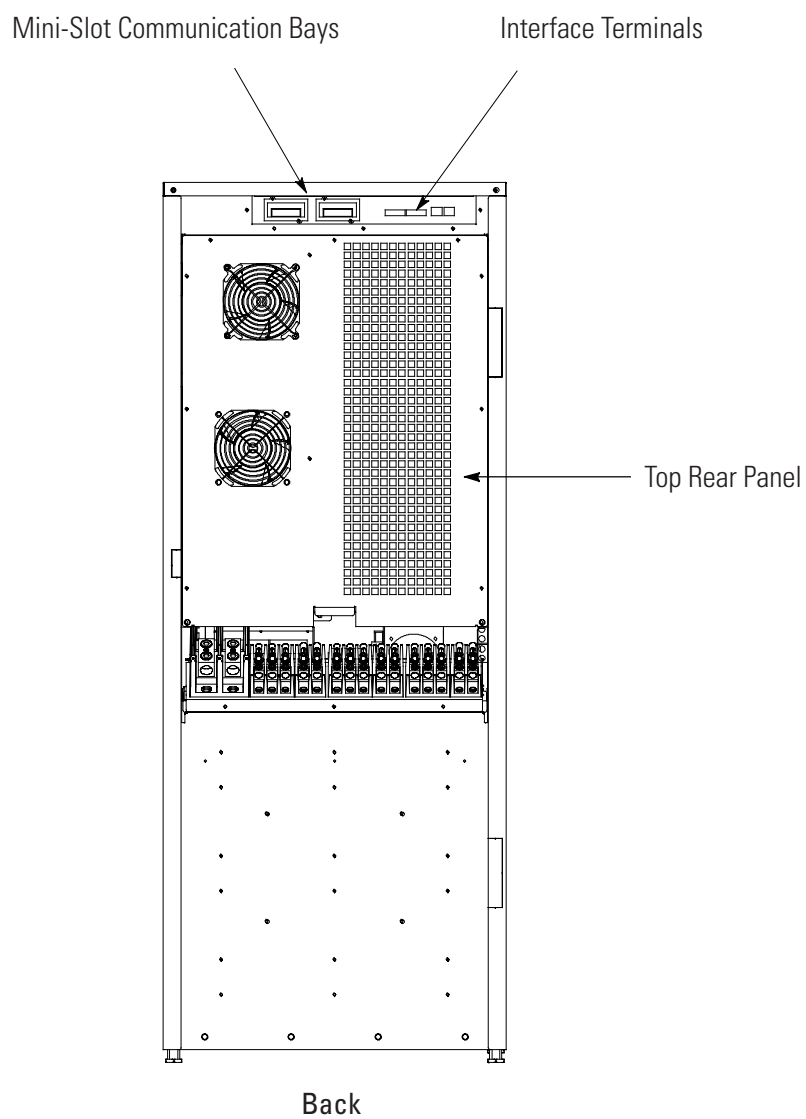

Figure 17. Interface Terminal Detail (Terminal Cover Removed)

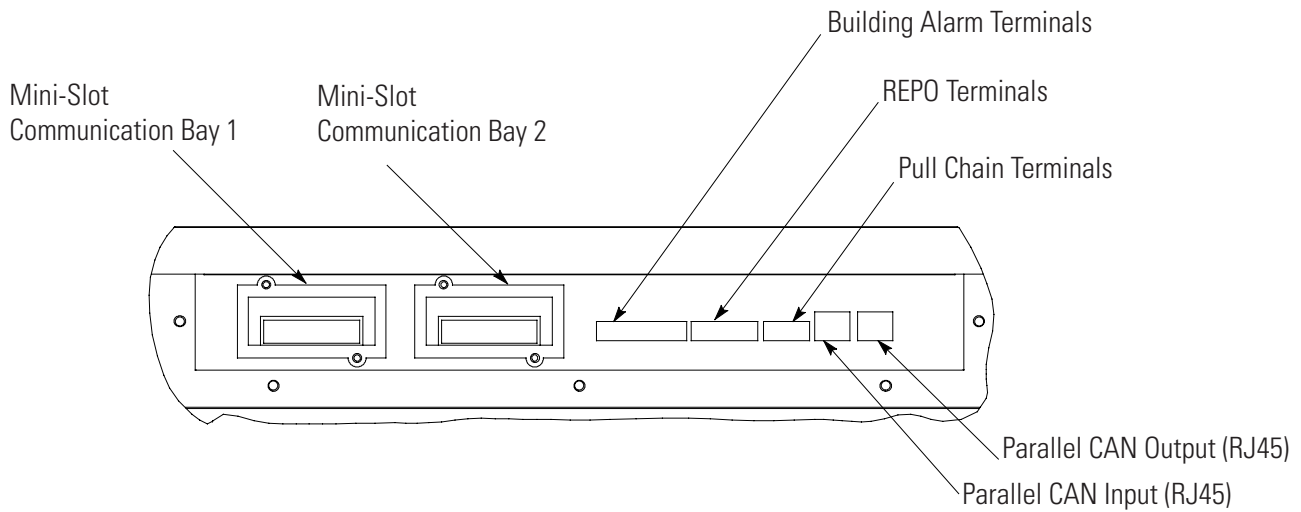

Figure 18. Building Alarm Terminal Block Connector Assignments

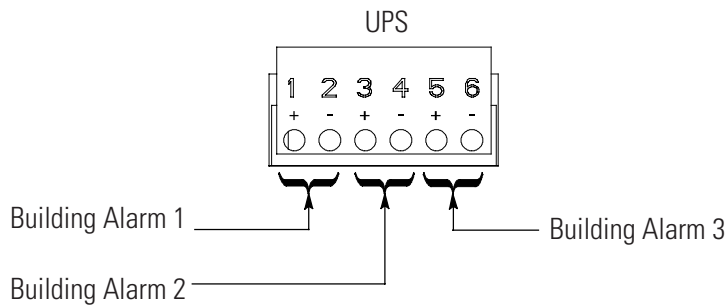

Table 11. Building Alarm Connections

Building Alarm Terminal	Name	Description
1	Building Alarm 1 +	Input: Programmable UPS alarm, activated by a remote dry contact closure.
2	Building Alarm 1 -	
3	Building Alarm 2 +	Input: Programmable UPS alarm, activated by a remote dry contact closure.
4	Building Alarm 2 -	
5	Building Alarm 3 +	Input: Programmable UPS alarm, activated by a remote dry contact closure.
6	Building Alarm 3 -	

3. Route the wiring to the terminal block:
 - a. If not already removed, remove the power terminal cover right and left sides (see [Figure 15](#)). Retain the cover top and hardware for later use.
 - b. If not already removed, remove the power terminal cover top. Retain the cover top and hardware for later use.



NOTE The lower fan is attached to the top rear panel.

- c. Remove the screws securing the top rear panel (see [Figure 16](#)). Supporting the panel, tilt the panel away from the cabinet and disconnect the fan connector from the wiring harness.
- d. Remove the panel. Retain the panel and hardware for later use.
- e. Remove the interface terminal cover (see [Figure 19](#)). Retain the cover and hardware for later use.



NOTE Conduit and wiring enter from the bottom of the conduit landing plate.

- f. Punch or drill a hole in the power terminal cover base (see [Figure 11](#), [Figure 12](#), and [Figure 20](#)) for the interface wiring conduit.
 - g. Route the wiring along the interface wiring channel (see [Figure 20](#)) to the wiring access (see [Figure 21](#)). Secure the wiring to the four mounting clips provided using Zip ties
 - h. Supporting the top rear panel at the back of the cabinet, reconnect the fan connector to the wiring harness.
 - i. Reinstall the top rear panel by tilting into position and securing the panel using the retained hardware.
 - j. Reinstall the power terminal cover top using the retained hardware.
 - k. Install the power terminal cover right and left sides using the provided hardware.
4. Connect the building alarm interface wiring as shown in [Table 11](#) and [Figure 18](#).
 5. Reinstall the interface terminal cover using the retained hardware.
 6. If wiring generator interface connections, proceed to paragraph [4.11.2 Generator Interface Connections](#); if wiring parallel connections, proceed to paragraph [4.11.3 Installing Parallel Pull Chain and CAN Control Wiring and Connections](#); if wiring Mini-Slot connections, proceed to paragraph [4.11.4 Installing Mini-Slot Interface Wiring and Connections](#); if wiring REPO connections, proceed to paragraph [4.12 Installing a REPO Switch](#); otherwise, proceed to [Step 7](#).
 7. Install the power terminal cover top using the provided hardware (see [Figure 15](#)).
 8. Install the power terminal cover right and left sides using the provided hardware.
 9. Close the UPS outside door and secure the latch.
 10. Proceed to paragraph [4.13 Connecting Internal Battery Strings](#).

Figure 19. Interface Terminal Cover

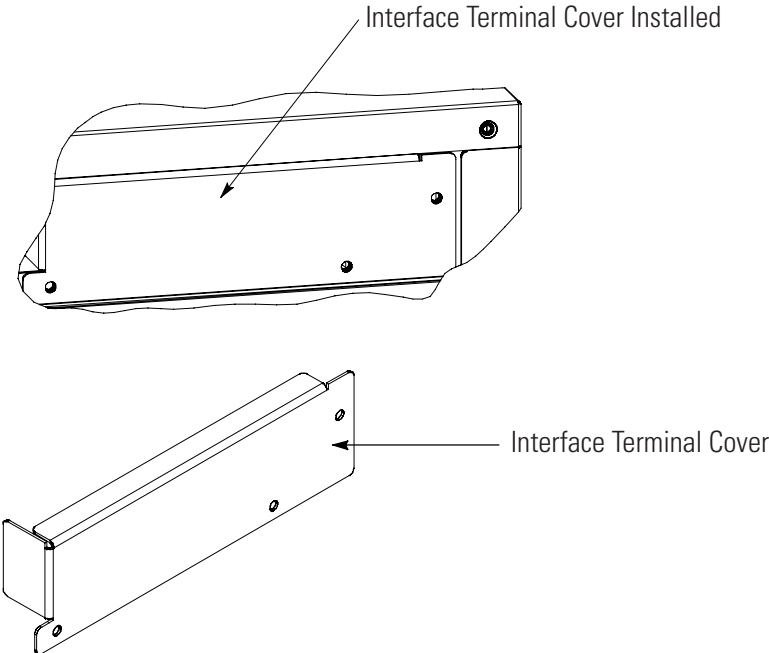

Figure 20. Interface Conduit Landing and Wiring Channel

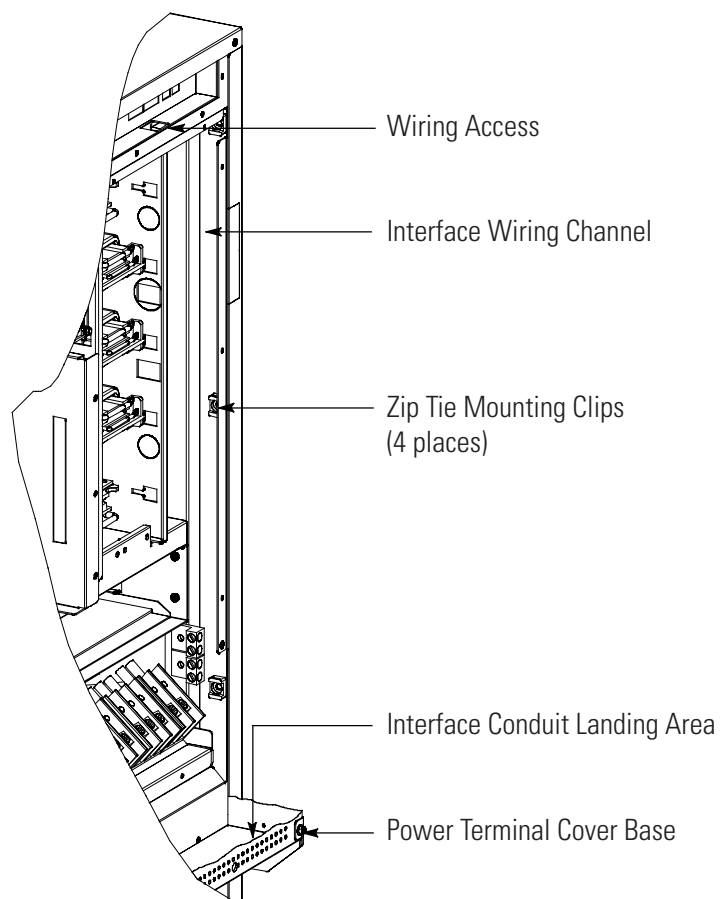
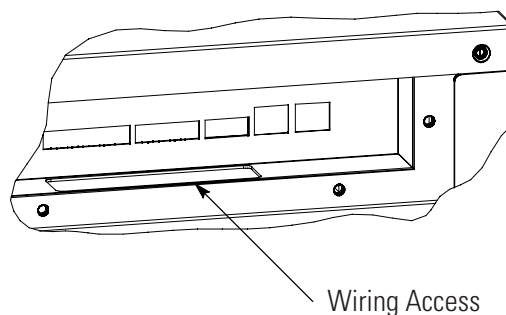

Figure 21. Interface Wiring Access



4.11.2 Generator Interface Connections

If High-Efficiency (HE) mode is enabled and the UPS will be fed by a site generator at any time, an On Generator building alarm must be wired and configured to a Building Alarm Input. Wiring the On Generator sensing circuit to a building alarm allows the UPS to optimize its operation with the generator by transferring the UPS from HE mode to Standard Normal (double conversion) mode.

NOTE 1 A UPS building alarm input is used to indicate On Generator.

NOTE 2 Any pair of unused building alarm terminals may be used for On Generator connections.



NOTE 3 Program the building alarm to read On Generator and for either Normally Open (default) or Normally Closed as required by the generator sensing output.

NOTE 4 If installing interface wiring connections between standalone cabinets, conduit must be installed between cabinets.

NOTE 5 Disconnect terminal block plugs from terminal blocks to wire plugs.

To Install wiring:

1. Verify the UPS system is turned off and all power sources are removed. See [Chapter 7 UPS Operating Instructions](#) for shutdown instructions.
2. If not already opened, open the front door by lifting the latch from the bottom and turning to the right (counterclockwise) and swing the door open.
3. Route the wiring to the terminal block:
 - a. If not already removed, remove the power terminal cover right and left sides (see [Figure 15](#)). Retain the cover top and hardware for later use.
 - b. If not already removed, remove the power terminal cover top. Retain the cover top and hardware for later use.



NOTE The lower fan is attached to the top rear panel.

- c. Remove the screws securing the top rear panel (see [Figure 16](#)). Supporting the panel, tilt the panel away from the cabinet and disconnect the fan connector from the wiring harness.
 - d. Remove the panel. Retain the panel and hardware for later use.
 - e. Remove the interface terminal cover (see [Figure 19](#)). Retain the cover and hardware for later use.
-
- NOTE** Conduit and wiring enter from the bottom of the conduit landing plate.
-
- f. Punch or drill a hole in the power terminal cover base (see [Figure 11](#), [Figure 12](#), and [Figure 20](#)) for the interface wiring conduit.
 - g. Route the wiring along the interface wiring channel (see [Figure 20](#)) to the wiring access (see [Figure 21](#)). Secure the wiring to the four mounting clips provided using Zip ties.
 - h. Supporting the top rear panel at the back of the cabinet, reconnect the fan connector to the wiring harness.
 - i. Reinstall the top rear panel by tilting into position and securing the panel using the retained hardware.
 - j. Reinstall the power terminal cover top using the retained hardware.
 - k. Install the power terminal cover right and left sides using the provided hardware.
 4. Connect the building alarm interface wiring as shown in [Table 11](#) and [Figure 18](#).

5. Reinstall the interface terminal cover using the retained hardware.
6. If wiring parallel connections, proceed to paragraph [4.11.3 Installing Parallel Pull Chain and CAN Control Wiring and Connections](#); if wiring Mini-Slot connections, proceed to paragraph [4.11.4 Installing Mini-Slot Interface Wiring and Connections](#); if wiring REPO connections, proceed to paragraph [4.12 Installing a REPO Switch](#); otherwise, proceed to [Step 7](#).
7. Install the power terminal cover top using the provided hardware (see [Figure 15](#)).
8. Install the power terminal cover right and left sides using the provided hardware.
9. Close the UPS outside door and secure the latch.
10. Proceed to paragraph [4.13 Connecting Internal Battery Strings](#).

4.11.3 Installing Parallel Pull Chain and CAN Control Wiring and Connections

To install wiring:

1. Verify the UPS system is turned off and all power sources are removed. See [Chapter 7 UPS Operating Instructions](#) for shutdown instructions.
2. To locate the appropriate terminals and review the wiring and termination requirements, see paragraph [3.2.3 UPS System Interface Wiring Preparation](#), [Table 12](#), [Figure 16](#), [Figure 17](#), and [Figure 22](#).

Figure 22. Pull Chain Terminal Block Connector Assignments

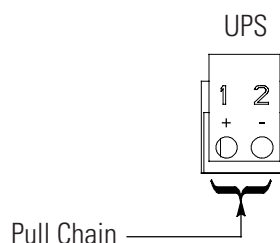

Table 12. Pull Chain Connections

Pull Chain Terminal	Name	Description
1	Pull Chain +	Output: Backup control for parallel operation.
2	Pull Chain -	

3. Route the wiring to the terminal block:
 - a. If not already removed, remove the power terminal cover right and left sides (see [Figure 15](#)). Retain the cover top and hardware for later use.
 - b. If not already removed, remove the power terminal cover top. Retain the cover top and hardware for later use.



NOTE The lower fan is attached to the top rear panel.

- c. Remove the screws securing the top rear panel (see [Figure 16](#)). Supporting the panel, tilt the panel away from the cabinet and disconnect the fan connector from the wiring harness.

- d. Remove the panel. Retain the panel and hardware for later use.
- e. Remove the interface terminal cover (see [Figure 19](#)). Retain the cover and hardware for later use.

**NOTE**

Conduit and wiring enter from the bottom of the conduit landing plate.

- f. Punch or drill a hole in the power terminal cover base (see [Figure 11](#), [Figure 12](#), and [Figure 20](#)) for the interface wiring conduit.
 - g. Route the wiring along the interface wiring channel (see [Figure 20](#)) to the wiring access (see [Figure 21](#)). Secure the wiring to the four mounting clips provided using Zip ties.
 - h. Supporting the top rear panel at the back of the cabinet, reconnect the fan connector to the wiring harness.
 - i. Reinstall the top rear panel by tilting into position and securing the panel using the retained hardware.
 - j. Reinstall the power terminal cover top using the retained hardware.
 - k. Install the power terminal cover right and left sides using the provided hardware.
4. Route and install RJ-45 Controller Area Network (CAN) cables between the UPS cabinets. See [Figure 17](#) and [Figure 23](#) for wiring information.
 5. Route and install pull chain wiring between the UPS cabinets and cabinet MOBs. See [Figure 17](#), [Figure 22](#), and [Figure 23](#) for wiring information.
 6. Reinstall the interface terminal cover using the retained hardware.
 7. If wiring Mini-Slot connections, proceed to paragraph [4.11.4 Installing Mini-Slot Interface Wiring and Connections](#); if wiring REPO connections, proceed to paragraph [4.12 Installing a REPO Switch](#); otherwise, proceed to [Step 8](#).
 8. Install the power terminal cover top using the provided hardware (see [Figure 15](#)).
 9. Install the power terminal cover right and left sides using the provided hardware.
 10. Proceed to paragraph [4.13 Connecting Internal Battery Strings](#).

4.11.4 Installing Mini-Slot Interface Wiring and Connections

**NOTE**

LAN drop for use with Mini-Slot cards must be provided by the customer.

For installation and setup of an Mini-Slot card, contact an Eaton service representative (see paragraph [1.8 Getting Help](#)).

To install wiring:

1. If not already installed, install the LAN drop.
2. Route and install the LAN and other cables to the appropriate Mini-Slot cards. See [Figure 16](#) and [Figure 17](#) for Mini-Slot communication bay locations.
3. Refer to the manual supplied with the Mini-Slot card for operator instructions.
4. If wiring REPO connections, proceed to paragraph [4.12 Installing a REPO Switch](#); otherwise, proceed to [Step 5](#).
5. Install the power terminal cover top using the provided hardware (see [Figure 15](#)).
6. Install the power terminal cover right and left sides using the provided hardware.
7. Proceed to paragraph [4.13 Connecting Internal Battery Strings](#).

Figure 23. Parallel UPS Control Wiring

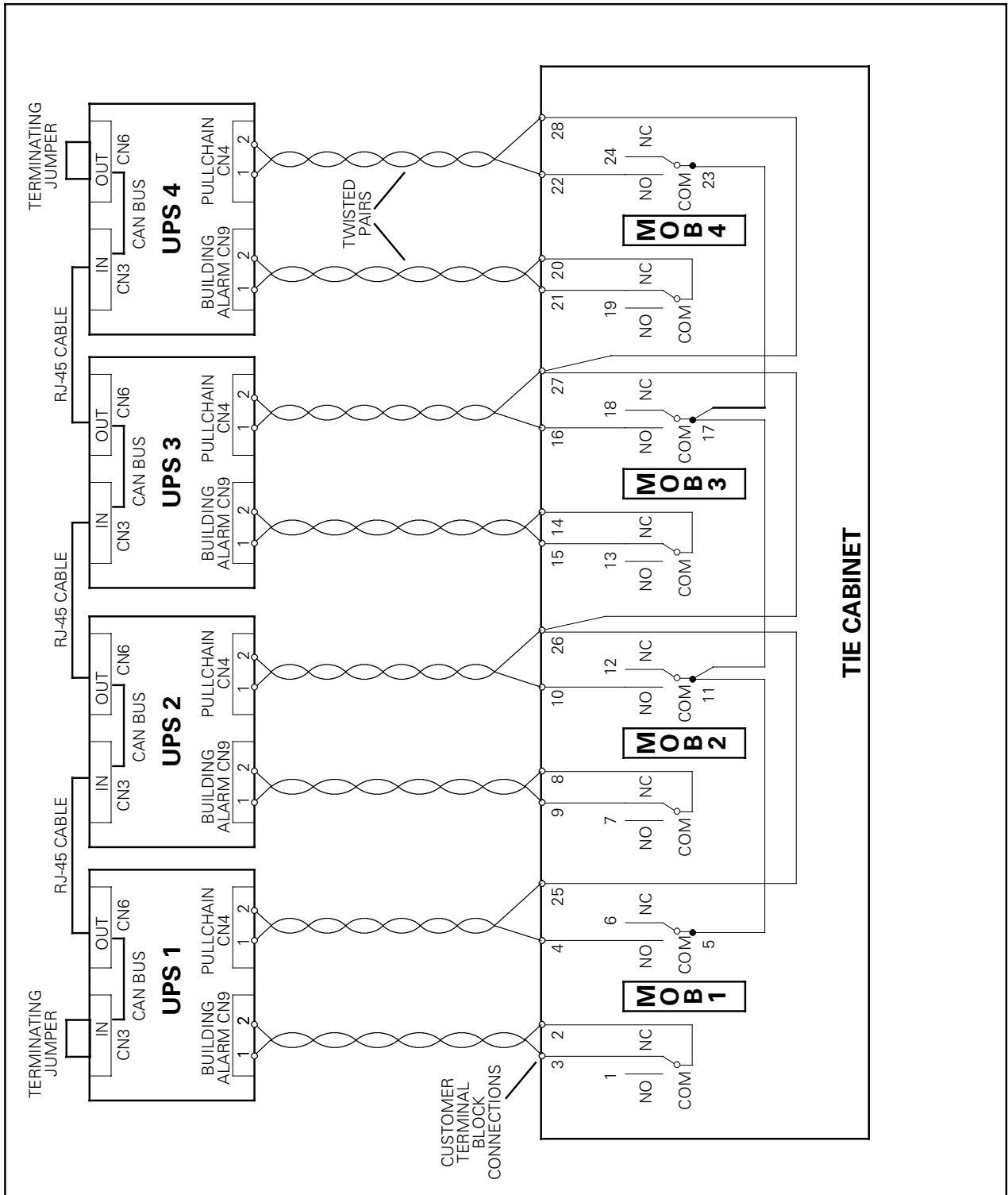

4.12 Installing a REPO Switch

A latching-type Remote Emergency Power-off (REPO) switch can be used in an emergency to shut down the UPS and remove power to the critical load from a location away from where the UPS is installed. [Figure 24](#) shows a REPO switch.

-
- NOTE 1** Before installing a REPO switch, verify that the UPS was installed according to the instructions in paragraphs [4.2 Unloading the UPS Cabinet from the Pallet](#) through [4.11 Installing Interface Wiring and Connections](#).
- NOTE 2** When installing the REPO switch, you must install conduit between the device and the UPS cabinet for wiring the switch.
- NOTE 3** The REPO switch must be a normally-open or normally-closed latching-type switch not tied into any other circuits.
- NOTE 4** This procedure is intended for installing the Eaton-supplied REPO switch. If installing another manufacturer's switch, use this procedure, and [Figure 26](#) and [Figure 27](#) as a guide.
- NOTE 5** The REPO switch wiring must be in accordance with NEC Article 725 Class 2 requirements.
-

To Install a REPO switch:

1. Verify the UPS system is turned off and all power sources are removed. See [Chapter 7 UPS Operating Instructions](#), for shutdown instructions.
2. Securely mount the REPO switch. Recommended locations include operator's consoles or near exit doors. See [Figure 5](#) for enclosure dimensions and wiring knockouts.
3. To locate the appropriate terminals and review the wiring and termination requirements, see paragraph [3.2.3 UPS System Interface Wiring Preparation](#), [Table 13](#), [Figure 16](#), [Figure 17](#), and [Figure 25](#).

Figure 24. REPO Switch

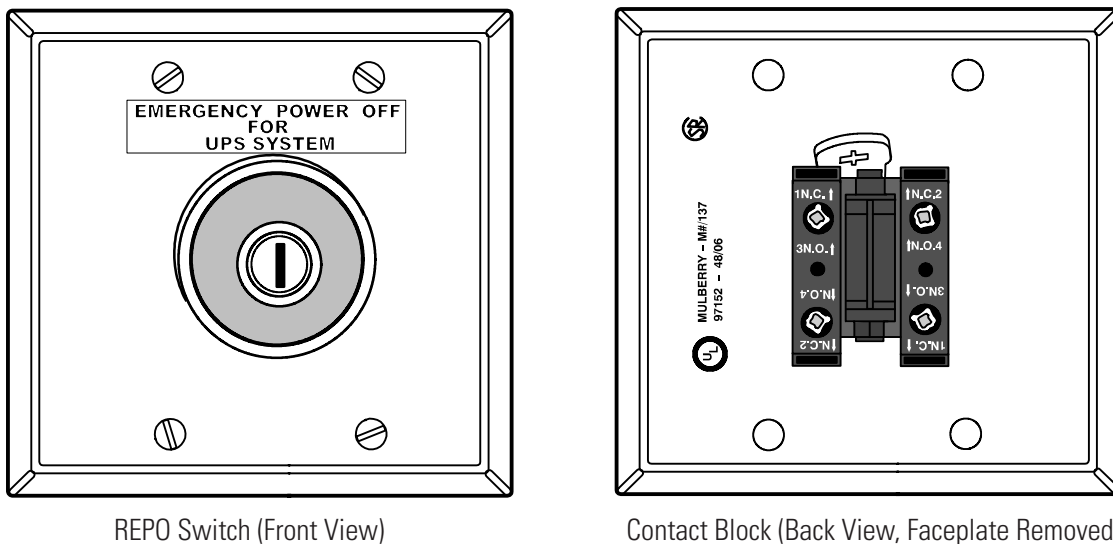
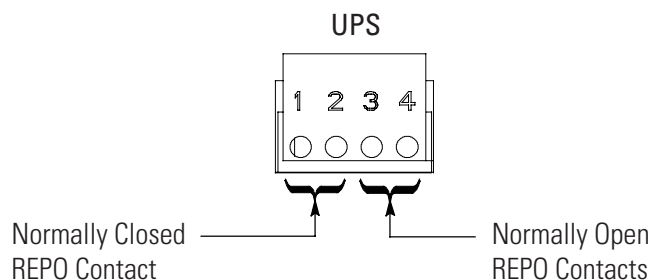

Figure 25. REPO Terminal Block Connector Assignments**Table 13. REPO Connections**

REPO Terminal	Description
1	Input: normally-closed dry contact used to activate UPS EPO from a remote switch.
2	
3	Input: normally-open dry contact used to activate UPS EPO from a remote switch.
4	

4. Route the REPO wiring to the terminal block:
 - a. If not already removed, remove the power terminal cover right and left sides (see [Figure 15](#)). Retain the cover top and hardware for later use.
 - b. If not already removed, remove the power terminal cover top. Retain the cover top and hardware for later use.

NOTE The lower fan is attached to the top rear panel.

- c. Remove the screws securing the top rear panel (see [Figure 16](#)). Supporting the panel, tilt the panel away from the cabinet and disconnect the fan connector from the wiring harness.
- d. Remove the panel. Retain the panel and hardware for later use.
- e. Remove the interface terminal cover (see [Figure 19](#)). Retain the cover and hardware for later use.

NOTE Conduit and wiring enter from the bottom of the conduit landing plate.

- f. Punch or drill a hole in the power terminal cover base (see [Figure 11](#), [Figure 12](#), and [Figure 20](#)) for the REPO conduit.
- g. Route the wiring along the interface wiring channel (see [Figure 20](#)) to the wiring access (see [Figure 21](#)). Secure the wiring to the four mounting clips provided using Zip ties.
- h. Supporting the top rear panel at the back of the cabinet, reconnect the fan connector to the wiring harness.
- i. Reinstall the top rear panel by tilting into position and securing the panel using the retained hardware.
- j. Reinstall the power terminal cover top using the retained hardware.

- k. Install the power terminal cover right and left sides using the provided hardware.
5. Connect the wiring as shown in [Table 14](#) and [Figure 26](#) for a normally-open REPO or [Table 15](#) and [Figure 27](#) for a normally-closed REPO.
6. If using a normally-closed REPO switch, connect a jumper wire between pins 3 and 4 on the REPO terminal block.
7. If you are installing multiple REPO switches, wire additional switches in parallel with the first REPO.
8. If required, install wiring from the REPO switch to the trip circuitry of the upstream protective devices. A second contact block is provided on the REPO switch for this function (see [Figure 24](#)). The REPO switch wiring must be in accordance with NEC Article 725 Class 2 requirements.
9. Reinstall the interface terminal cover using the retained hardware.

Table 14. Normally-Open REPO Wire Terminations

From REPO Station(s) Switch Contact Block (Either Block)	To REPO Terminal Block on Back of UPS Cabinet	Wire Size	Tightening Torque
3 NO	3	Twisted Wires (2)	7 lb in
4 NO	4	14-22 AWG (0.75 4.0 mm ²)	(0.8 Nm)

Figure 26. Normally-Open REPO Switch Wiring

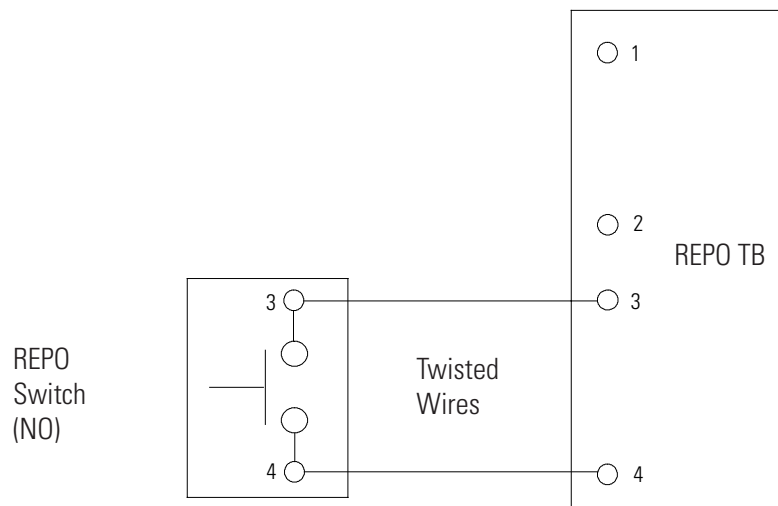
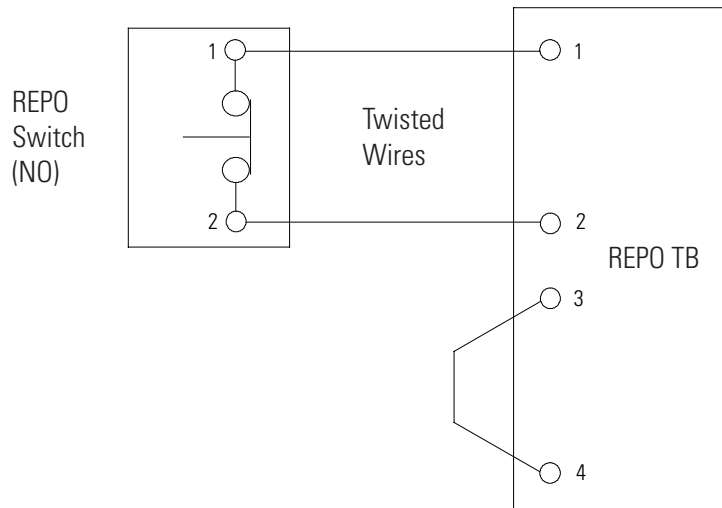

Table 15. Normally-Closed REPO Wire Terminations

From REPO Station(s) Switch Contact Block (Either Block)	To REPO Terminal Block on Back of UPS Cabinet	Wire Size	Tightening Torque
3 NO	1	Twisted Wires (2)	7 lb in
4 NO	2	14-22 AWG (0.75 4.0 mm ²)	(0.8 Nm)

Figure 27. Normally-Closed REPO Switch Wiring

4.13 Connecting Internal Battery Strings

DANGER

This battery section contains its own energy source. Risk of electric shock. Do not touch uninsulated battery terminals. The internal wiring may carry LETHAL VOLTAGES.

WARNING

Internal battery strings should be connected by a qualified electrical contractor knowledgeable of battery systems, and required precautions.

CAUTION

Connect battery strings only after all wiring is complete.

The UPS is shipped with each battery tray string electrically disconnected. To connect the battery tray strings:

1. If not already open, open the front door (see [Figure 7](#)) by lifting the latch from the bottom and turning to the right (counterclockwise) and swing the door open.
2. Remove the screws securing the bottom internal safety shield panel (see [Figure 28](#)) and remove the panel to gain access to the battery section (see [Figure 29](#)). Retain the hardware for later use.
3. Connect the red and black connectors marked with the white flags (see [Figure 30](#)) for each set of batteries on the battery shelf.
4. Connect the black connectors (see [Figure 30](#)) for each set of batteries on the battery shelf.
5. Connect the red connectors (see [Figure 30](#)) for each set of batteries on the battery shelf.



NOTE

The Eaton 93E-20 model has battery strings installed on two shelves. The Eaton 93E-30/20 and Eaton 93E-30/30 models have battery strings installed on three shelves.

6. Repeat [Step 3](#) through [Step 5](#) for each battery shelf (see [Figure 29](#)) to complete the battery string connections.
7. Reinstall the internal safety shield panel removed in [Step 2](#).
8. Close the outside door and secure the latch.

Figure 28. Battery Location

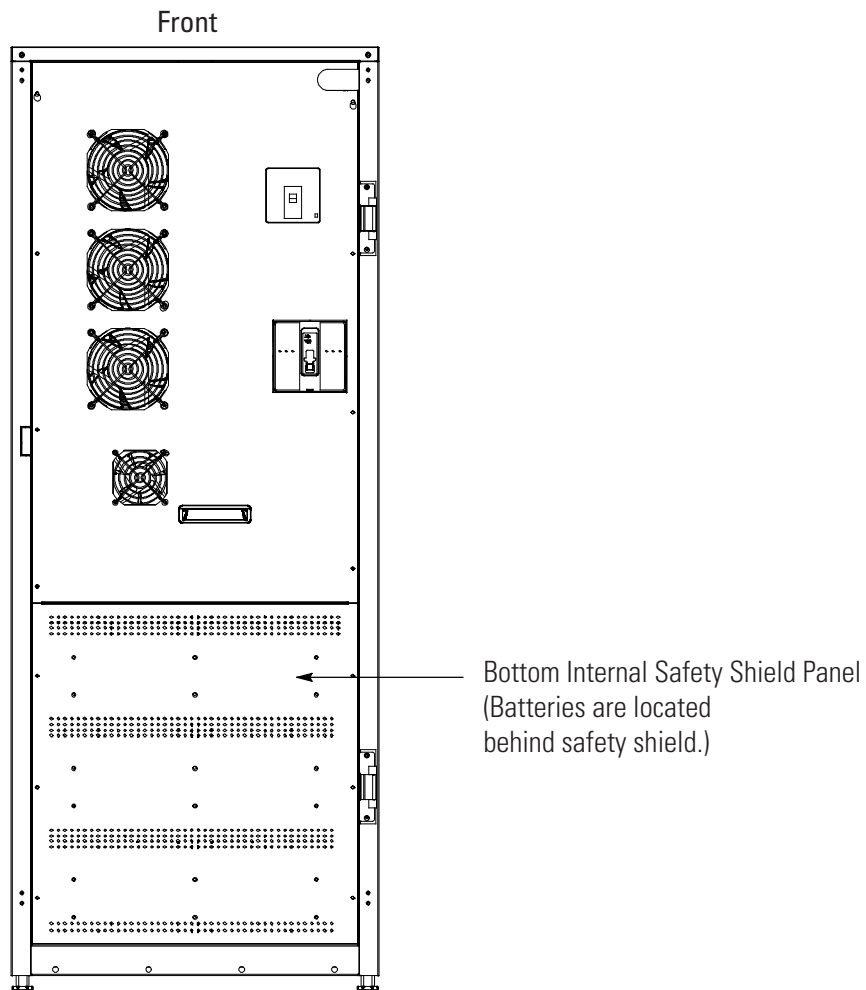
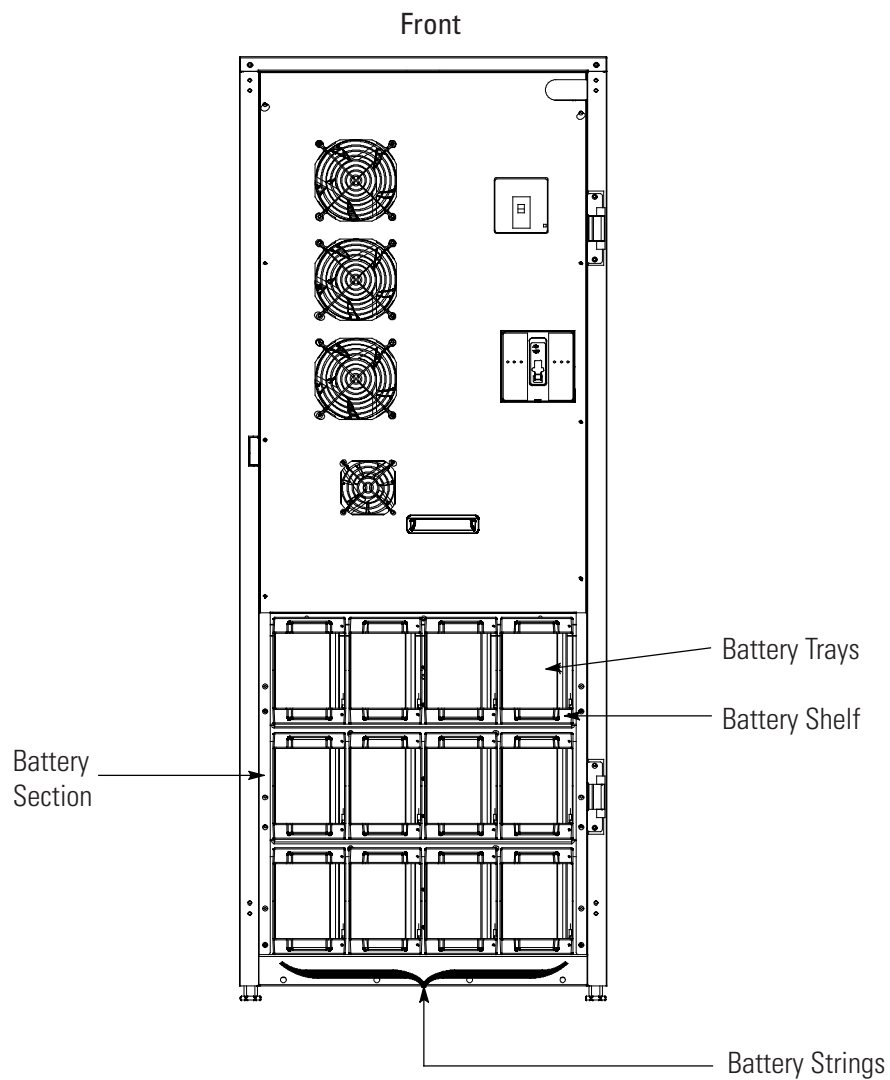
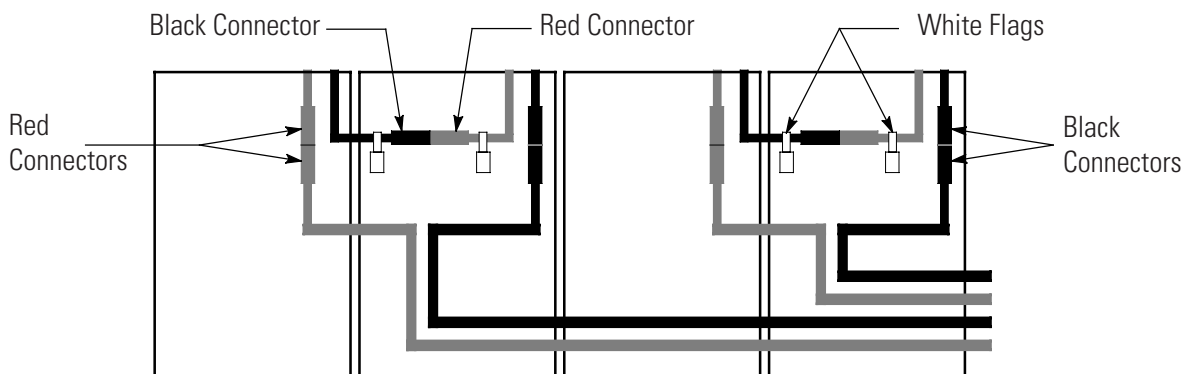

Figure 29. Battery Section



NOTE The Eaton 93E-20 model has battery strings installed on two shelves. The Eaton 93E-30/20 and Eaton 93E-30/30 models have battery strings installed on three shelves.

Figure 30. Battery String Connections

4.14 Initial Startup

Startup may be performed by the customer's battery qualified electrical contractor for single (not parallel) UPS installations without any accessory cabinets such as an External Battery Cabinet.

Startup and operational checks for parallel systems or installations with accessory cabinets must be performed by an authorized Eaton Customer Service Engineer, or the warranty terms specified on product's resources page become void. See [Chapter 11 Warranty](#) for details. This service is offered as part of the sales contract for the UPS. Contact an Eaton service representative in advance (usually a two-week notice is required) to reserve a preferred startup date.

4.15 Completing the Installation Checklist

The final step in installing the UPS system is completing the following Installation Checklist. This checklist ensures that you have completely installed all hardware, cables, and other equipment. Complete all items listed on the checklist to ensure a smooth installation. Make a copy of the Installation Checklist before filling it out, and retain the original.

After the installation is complete, an Eaton Customer Service Engineer must verify the operation of the UPS system and commission it to support the critical load. The service representative cannot perform any installation tasks other than verifying software and operating setup parameters. Service personnel may request a copy of the completed Installation Checklist to verify all applicable equipment installations have been completed.



NOTE

The Installation Checklist **MUST** be completed prior to starting the UPS system for the first time.

Installation Checklist

- All packing materials and restraints have been removed from each cabinet.
- The UPS cabinet is placed in its installed location
- All conduits and cables are properly routed to the UPS and any ancillary cabinets.
- All power cables are properly sized and terminated.
- Neutral conductors are installed.

- A ground conductor is properly installed.
- Building alarms are wired appropriately. (Optional)
- LAN drops are installed. (Optional)
- LAN connections have been completed. (Optional)
- The REPO device is mounted in its installed location and its wiring is terminated inside the UPS cabinet. (Optional)
- A jumper wire is connected between pins 3 and 4 on the REPO terminal block if using a normally-closed REPO switch. (Optional)
- Internal battery strings are connected after all other wiring is complete.
- All terminal cover plates are installed.
- Accessories are mounted in installed locations and wiring is terminated inside the UPS cabinet. (Optional)
- Air conditioning equipment is installed and operating correctly.
- The area around the installed UPS system is clean and dust-free. (Eaton recommends that the UPS be installed on a level floor suitable for computer or electronic equipment.)
- Adequate workspace exists around the UPS and other cabinets.
- Adequate lighting is provided around all UPS equipment.
- A 120 Vac service outlet is located within 7.5 meters (25 feet) of the UPS equipment.
- Startup and operational checks are performed by an authorized Eaton Customer Service Engineer for installations with accessory cabinets.
- Visit www.eaton.com/pg/register to register your new Eaton UPS / Eaton UPS Accessory.

Parallel System Installation Checklist

- Each cabinet in the parallel system is placed in its installed location.
- All conduits and cables are properly routed to the UPSs and to the parallel tie cabinet.
- All power cables are properly sized and terminated.
- Neutral conductors are installed between cabinets as required.
- ground conductors are properly installed.
- CAN wiring between the UPSs is properly installed.
- Pull chain wiring between the UPSs is properly installed.
- Adequate workspace exists around the UPSs, parallel tie cabinet, and other cabinets.
- Startup and operational checks are performed by an authorized Eaton Customer Service Engineer for parallel systems.
- Visit www.eaton.com/pg/register to register your new Eaton UPS / Eaton UPS Accessory.

Notes

Chapter 5 Understanding UPS Operation

5.1 UPS System Overview

The Eaton 93E UPS is a continuous-duty, solid-state, transformerless, three-phase, true online system that provides conditioned and uninterruptible AC power to the UPS system's output and critical load.

The basic system consists of a rectifier, battery converter, inverter, monitoring/operation control panel, integrated communication server, and digital signal processor (DSP) logic. [Figure 31](#) shows the main elements of the UPS system.

If utility power is interrupted or falls outside the parameters specified in Chapter 10, Product Specifications, the UPS uses a backup battery supply to maintain power to the critical load for a specified period of time or until the utility power returns. For extended power outages, the UPS allows you to either transfer to an alternative power system (such as a generator) or shut down your critical load in an orderly manner.

Figure 31. Main Elements of the UPS System

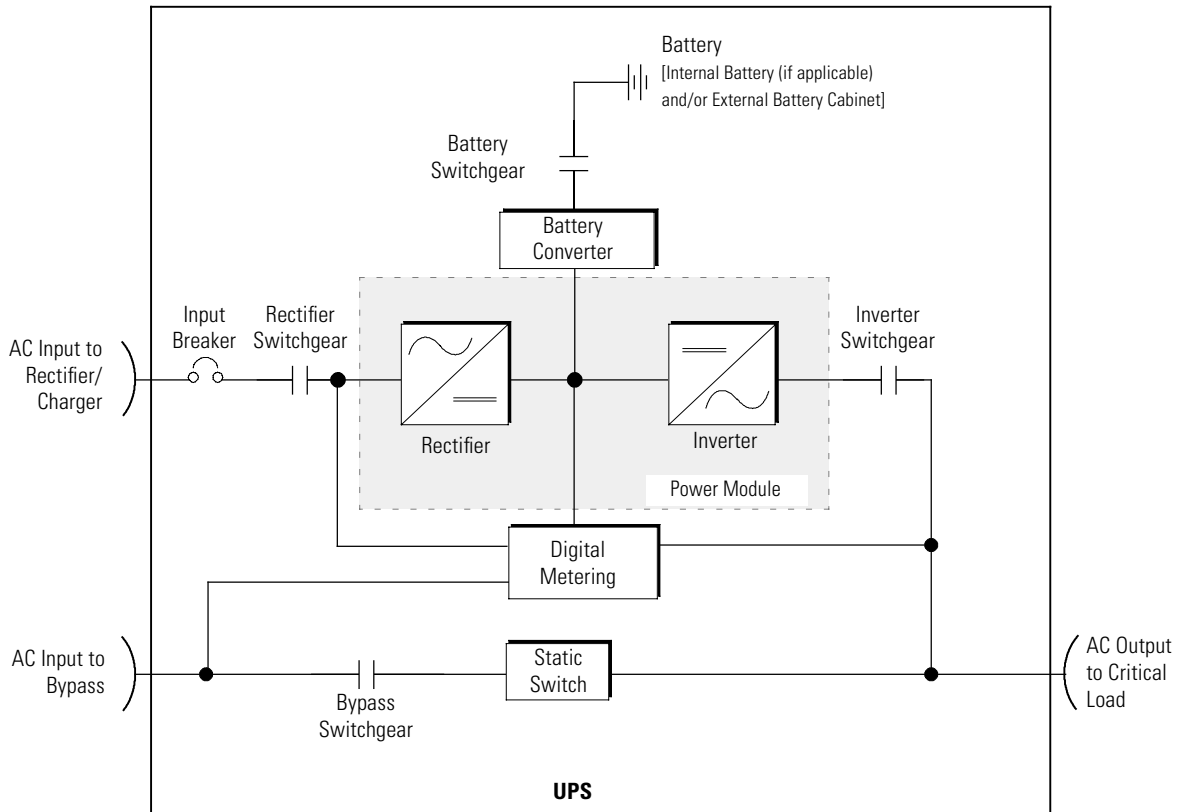

The emergency bypass consists of a continuous static switch, and a bypass switchgear. The bypass switchgear is located in series with the static switch. The static switch is armed and ready during normal operation.

5.2 Single UPS

A single UPS operates independently to support an applied load from the inverter, providing conditioned and uninterruptible AC power to the critical load from the output of the module. During an outage, the inverter continues to operate, supporting power to the load from the battery supply. If the unit requires service, applied loads are transferred to the internal bypass either automatically or manually. With the exception of an optional external battery cabinet, no other cabinets or equipment are required for the single UPS to successfully support its applied loads.

5.2.1 Modes

The Eaton 93EUPS supports a critical load in four different modes of operation:

- In High-Efficiency (HE) Normal mode, commercial AC power is supplied directly to the critical load through the internal bypass and transfers automatically to Standard Normal mode (double-conversion on demand) if an abnormal condition is detected. HE mode is the default normal operating mode.
- In Standard Normal mode, the critical load is supplied by the inverter, which derives its power from rectified utility AC power. In this mode, the battery charger also provides charging current for the battery, if needed.
- In Bypass mode, the critical load is directly supported by utility power.
- In Battery mode, the battery provides DC power, which maintains inverter operation. The battery supports the critical load.

The following paragraphs describe the differences in the UPS operating modes, using block diagrams to show the power flow during each mode of operation.

5.2.2 High-Efficiency Normal Mode

When the UPS is operating in HE mode, commercial AC power is supplied directly to the critical load through the internal bypass with the power module in a standby state. If a commercial power brownout, blackout, overvoltage, undervoltage, or out-of-tolerance frequency condition occurs the system forward transfers to normal mode (double-conversion on demand) or battery mode. When the input line returns to normal operating range, the UPS returns to HE operation. For charging batteries in HE mode, the UPS will revert to normal mode to charge the batteries, then return to HE mode when charge cycle is complete.

HE mode is the default normal operating mode, and not an alarm condition. While the UPS is in this mode, the NORMAL light on the front display will illuminate.

5.2.3 Standard Normal Mode

During Standard Normal mode, power for the system is derived from a utility input source through the rectifier switchgear. Three-phase AC input power is converted to DC using IGBT devices to produce a regulated DC voltage to the inverter. When the battery switchgear is closed the battery is charged directly from the regulated rectifier output through a buck or boost DC converter, depending on the system voltage and the size of the battery string attached to the unit.

[Figure 32](#) shows the path of electrical power through the UPS system when the UPS is operating in Normal mode.

The battery converter derives its input from the regulated DC output of the rectifier and provides either a boosted or bucked regulated DC voltage charge current to the battery. The battery is always connected to the UPS and ready to support the inverter should the utility input become unavailable.

The inverter produces a three-phase AC output to a customer's load without the use of a transformer. The inverter derives regulated DC from the rectifier and uses IGBT devices and pulse-width modulation (PWM) to produce a regulated and filtered AC output. The AC output of the inverter is delivered to the system output through the inverter switchgear.

If the utility AC power is interrupted or is out of specification, the UPS automatically switches to Battery mode to support the critical load without interruption. When utility power returns, the UPS returns to Normal mode.

Figure 32. Path of Current Through the UPS in standard Normal Mode

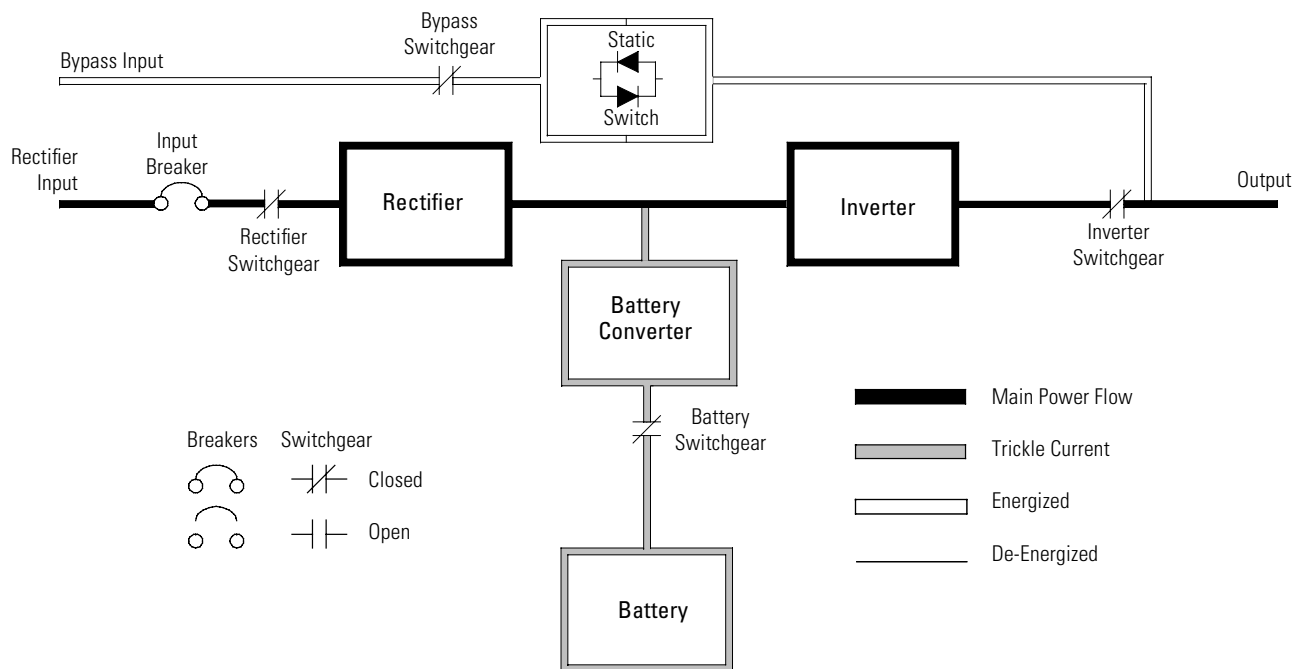

If the UPS becomes overloaded or unavailable, the UPS switches to Bypass mode. The UPS automatically returns to Normal mode when the overload condition is cleared and system operation is restored within specified limits.

If the UPS suffers an internal failure, it switches automatically to Bypass mode and remains in that mode until the failure is corrected and the UPS is back in service.

5.2.4 Bypass Mode

⚠ CAUTION

The critical load is not protected from voltage or frequency fluctuations or power outages while the UPS is in Bypass mode.

The UPS automatically switches to Bypass mode if it detects an overload, load fault, or internal failure. The UPS can also be transferred from Normal mode to Bypass mode manually. The bypass source supplies the commercial AC power to the load directly. [Figure 33](#) shows the path of electrical power through the UPS system when operating in Bypass mode.

In Bypass mode, the output of the system is provided with three-phase AC power directly from the system input. While in this mode, the output of the system is not protected from voltage or frequency fluctuations or power outages from the source. Some power line filtering and spike protection is provided to the load but no active power conditioning or battery support is available to the output of the system in the Bypass mode of operation.

The internal bypass is comprised of a solid-state, silicon-controlled rectifier (SCR) continuous static switch, and the bypass switchgear. The static switch is used instantaneously anytime the inverter is unable to support the applied load. The continuous static switch is wired in parallel with the rectifier and inverter.

The static switch, being an electronically-controlled device, can be turned on immediately to pick up the load from the inverter while inverter switchgear opens to isolate the inverter. The bypass switchgear is normally closed, ready to support the static switch unless the bypass input source becomes unavailable.

If the UPS transfers to Bypass mode from Normal mode due to any reason other than operator intervention, the UPS automatically attempts to transfer back to Normal mode (up to three times within a ten minute period). The fourth transfer locks the critical load to the bypass source and requires operator intervention to transfer.

Figure 33. Path of Current Through the UPS in Bypass Mode

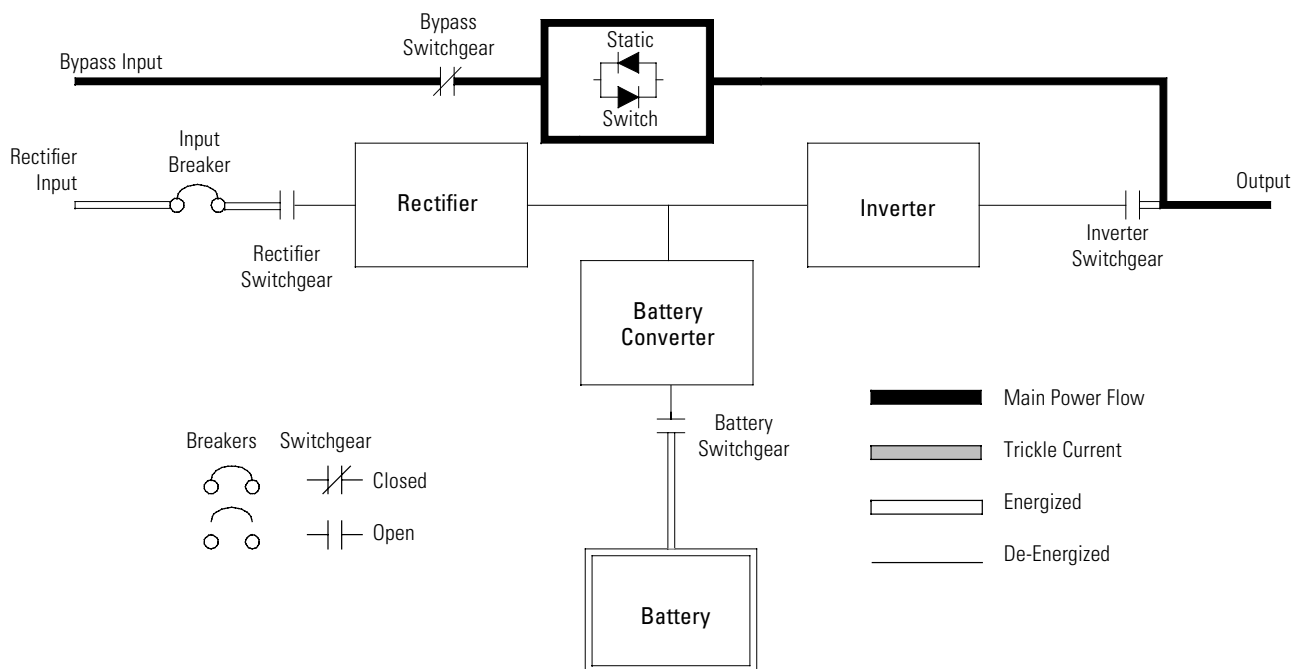

5.2.5 Battery Mode

The UPS automatically transfers to Battery mode if a utility power outage occurs, or if the utility power does not conform to specified parameters. In Battery mode, the battery provides emergency DC power that the inverter converts to AC power.

[Figure 34](#) shows the path of electrical power through the UPS system when operating in Battery mode.

Figure 34. Path of Current Through the UPS in Battery Mode

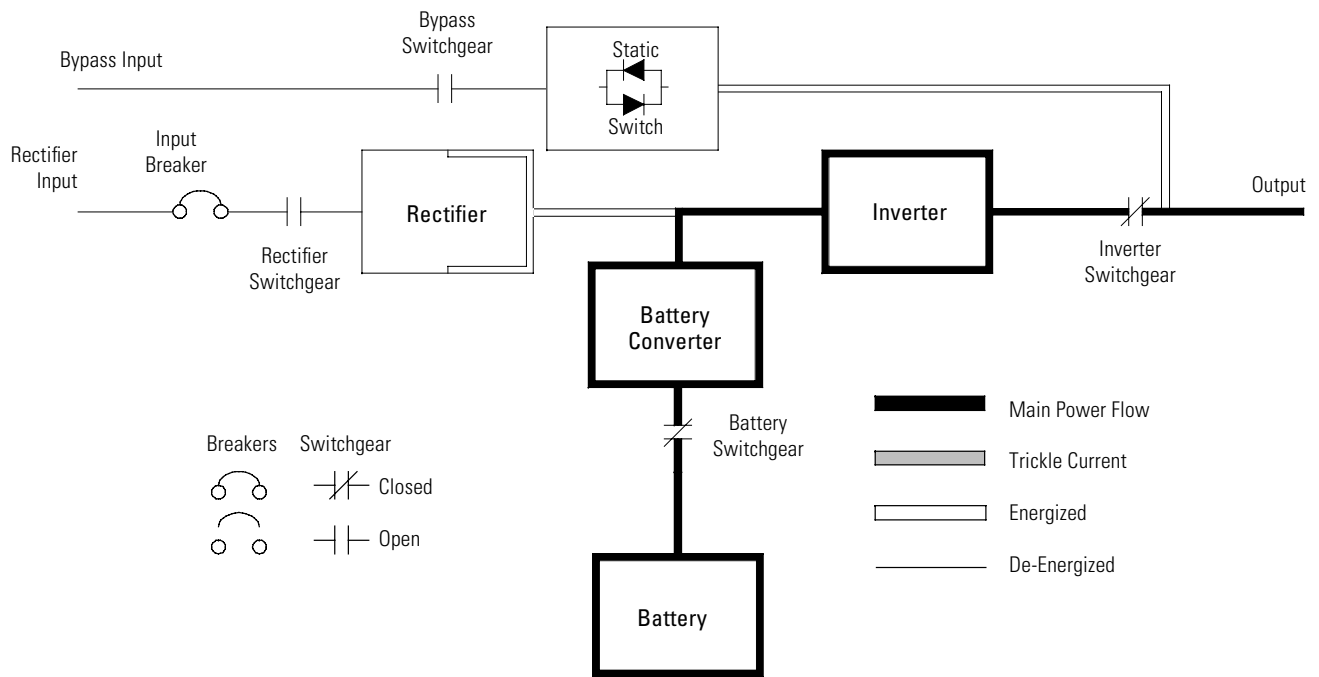

During a utility power failure, the rectifier no longer has an AC utility source from which to supply the DC output voltage required to support the inverter. The rectifier switchgear opens and the battery instantaneously supplies energy to the battery converter. The converter boosts the voltage so that the inverter can support the customer's load without interruption. If bypass is common with the rectifier input, the bypass switchgear also opens. The opening of the rectifier and the bypass switchgear prevent system voltages from bleeding backwards through the static switch and rectifier snubber components to the utility source.

If the input power fails to return or is not within the acceptance windows required for normal operation, the battery continues discharging until a DC voltage level is reached where the inverter output can no longer support the connected loads. When this event occurs, the UPS issues another set of audible and visual alarms indicating SHUTDOWN IMMINENT. Unless the rectifier has a valid AC input soon, the output can be supported for only two minutes before the output of the system shuts down. If the bypass source is available, the UPS transfers to bypass instead of shutting down.

If at any time during the battery discharge the input power becomes available again, the rectifier and the bypass switchgear close and the rectifier begins to supply DC current to the converter and inverter. At this point, the unit returns to Normal mode. Depending on the total load and the duration of the battery discharge, battery current limit alarms may be seen for a short time due to the current required to recharge the battery.

Chapter 6 UPS System Online Configurations

The system online drawings in this section show the simplified internal structure of the UPS, battery supply, and basic maintenance bypass.

Online Drawing	UPS Model	Voltage		System Type
		Input	Output	
See Figure 35	93E-20	208/220	208/220	Single Reverse Transfer UPS with Internal Battery (No External Battery Capability)
See Figure 36	93E-30/20 93E-30/30	208/220	208/220	Single Reverse Transfer UPS with Internal Battery and External Battery Capable
See Figure 37	93E-30/20 93E-30/30	208/220	208/220	Single Reverse Transfer UPS with Internal and External Batteries

Figure 35. UPS System Online – 93E–20 Internal Battery (No External Battery Capability)

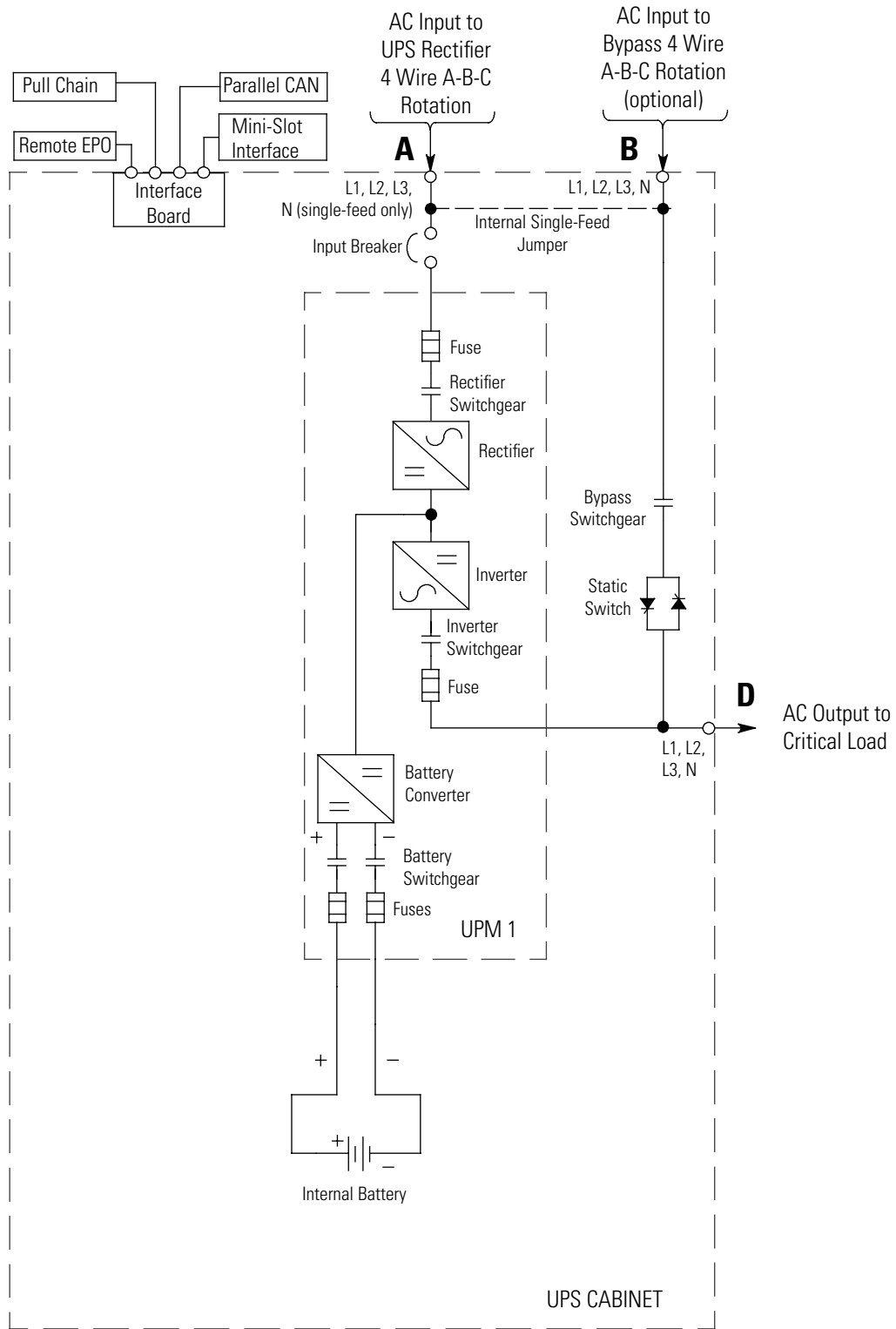

Figure 36. UPS System Online – Internal Battery and External Battery Capable

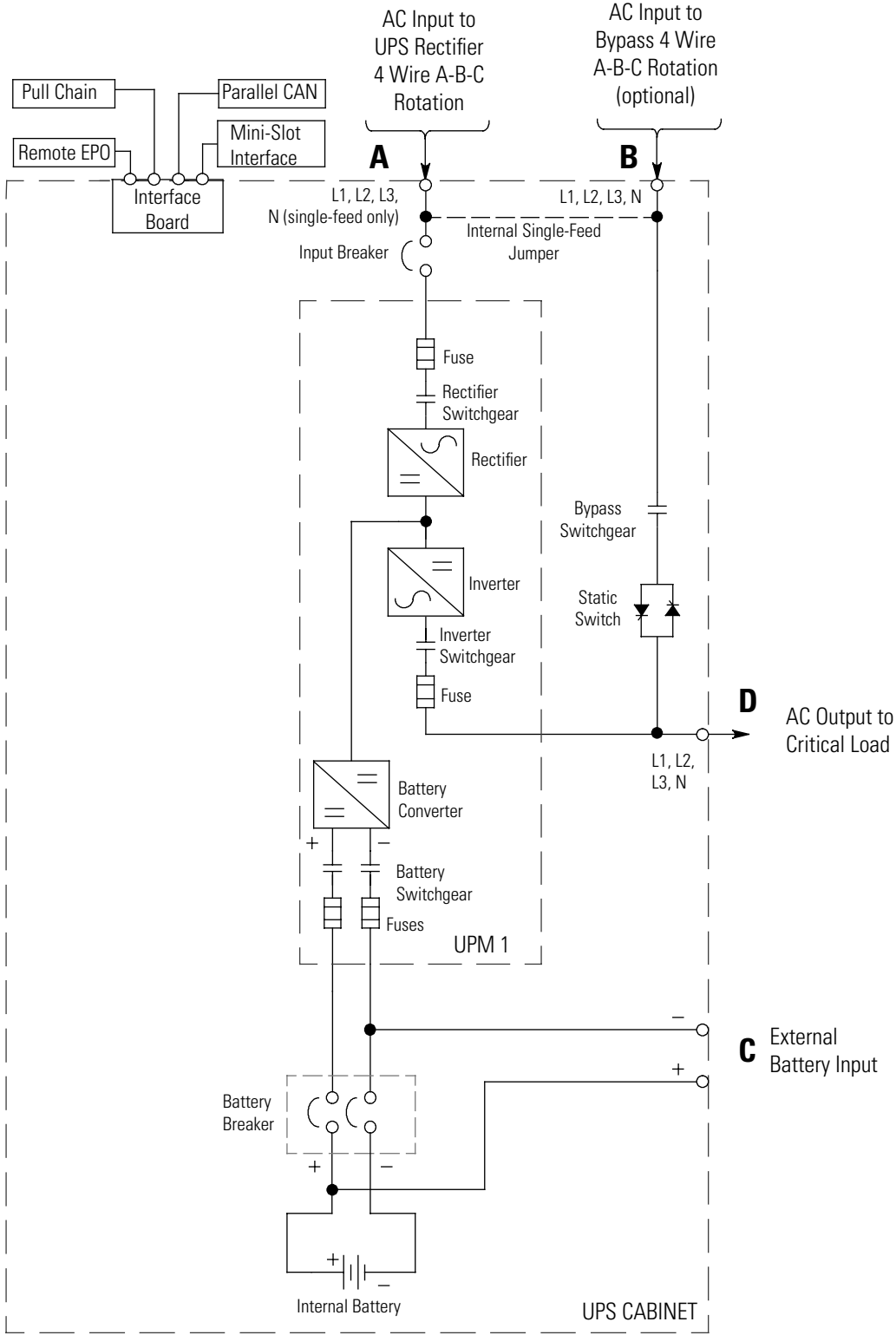
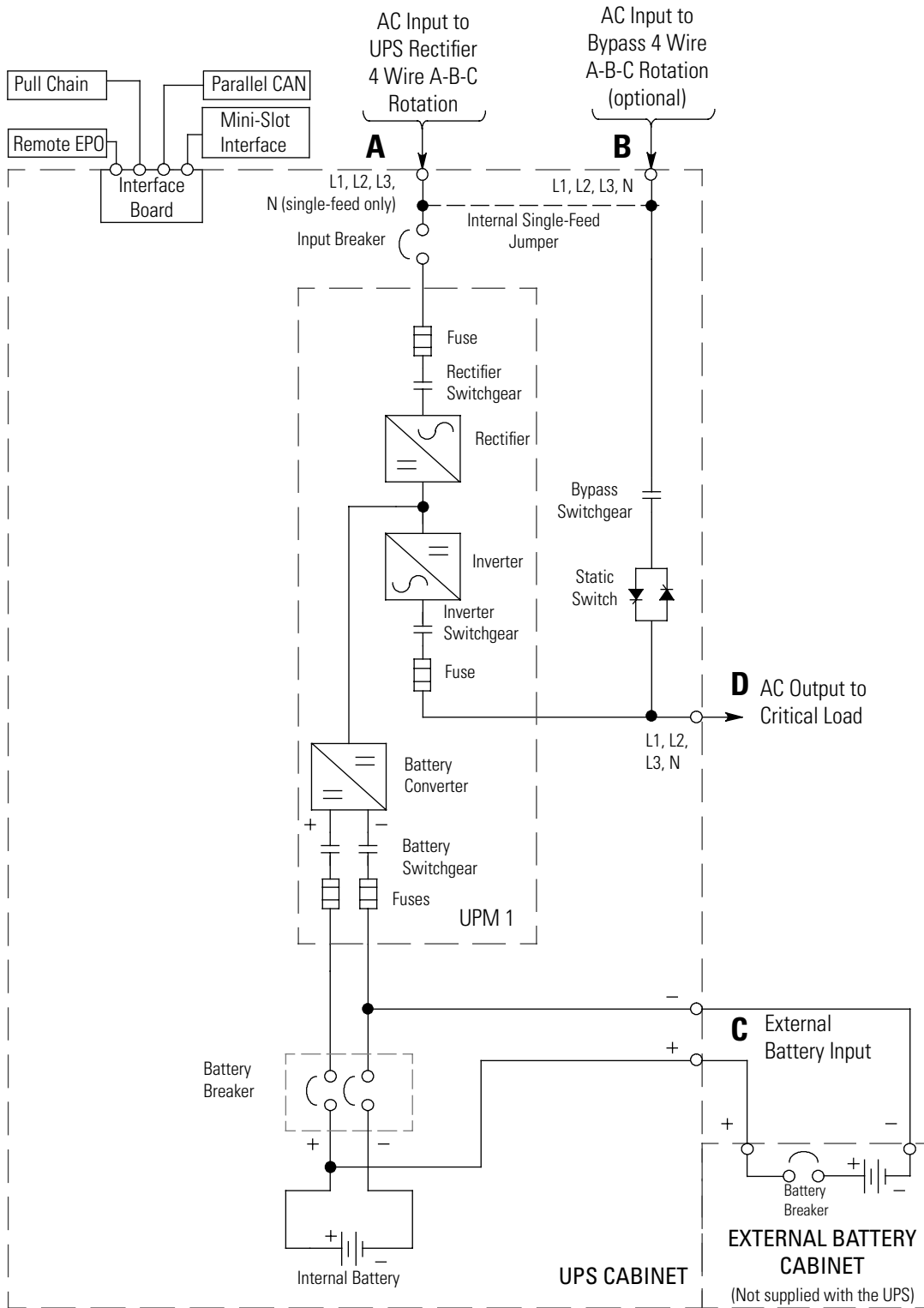

Figure 37. UPS System Online – Internal and External Batteries



Chapter 7 UPS Operating Instructions

This section describes how to operate the UPS.

-
- NOTE 1** Before starting the UPS, ensure all installation tasks are complete and a preliminary startup has been performed by authorized service personnel. The preliminary startup verifies all electrical interconnections to ensure the installation was successful and the system operates properly.
- NOTE 2** Read this section of the manual and have thorough knowledge of UPS operation before attempting to operate any of the controls.
-

7.1 UPS Controls and Indicators

The controls and indicators identified and described in this section are used to control and monitor UPS operation. [Figure 38](#) shows the controls and indicators and [Figure 39](#) shows the UPS breakers.

Figure 38. UPS Controls and Indicators

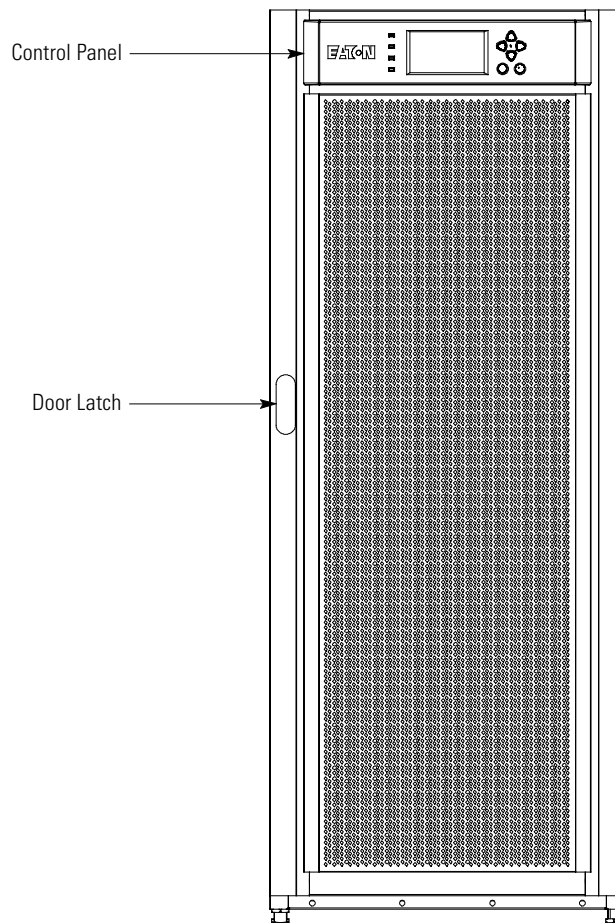
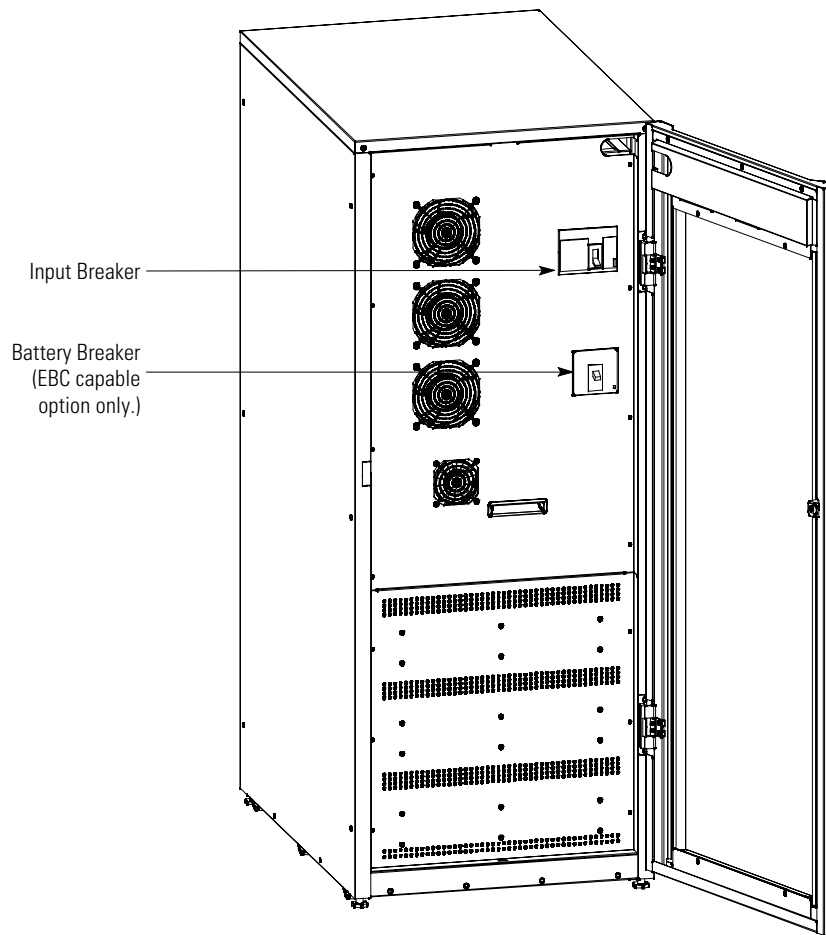

Figure 39. UPS Breakers



7.1.1 Control Panel

The control panel is used to set up and control the UPS, and to monitor UPS operation. For a description of the UPS control panel functions, see paragraph [7.2 Using the Control Panel](#).

7.1.2 Circuit Breakers

- **Input Circuit Breaker** – The Input circuit breaker is used to control the AC input to the UPS rectifier.
- **Battery Circuit Breaker** – The optional Battery circuit breaker is used to control the DC input to the UPS when the External Battery Cabinet (EBC) capable option is installed. This breaker disconnects both internal and external batteries.

7.2 Using the Control Panel

The following paragraphs describe the UPS control panel, including controls and indicators, and how to monitor UPS operation. The control panel (see [Figure 40](#)) is located on the front door of the UPS.

Figure 40. UPS Control Panel

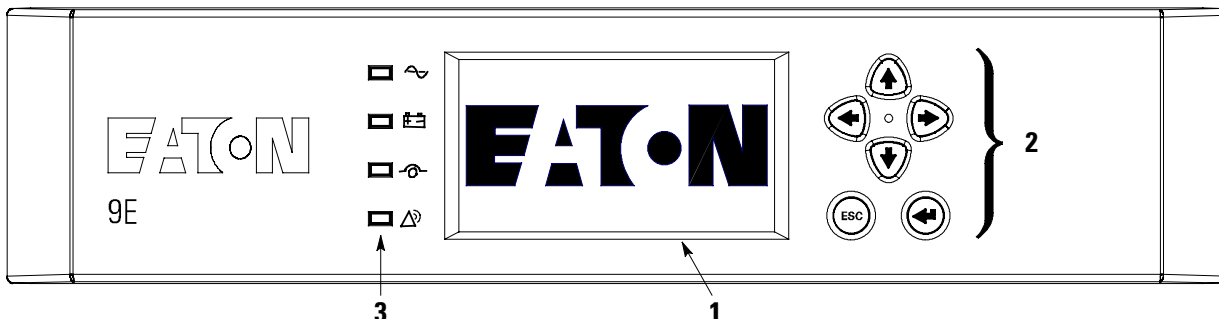

The control panel consists of:

- A liquid crystal display (LCD) (1)
- Menu navigation pushbutton switches (2)
- A vertical column of status indicators (3). See paragraph [7.2.1 Status Indicators](#).

The following paragraphs describe using the UPS control panel to monitor the UPS. See paragraph [7.3 Single UPS Operation](#) for use of the operational controls.

When the unit powers up, the screen displays the Eaton logo as shown in [Figure 40](#). To advance to the Main Menu and Mimic screen, press any control panel pushbutton once.

7.2.1 Status Indicators

The four symbols on the right side of the control panel are status indicators. These colored light emitting diode (LED) lamps work with the alarm horn to let you know the operating status of the UPS.

[Table 16](#) describes the status indicators.

Table 16. Status Indicators









Indicator	Status	Description
  Green	On	The UPS is in Normal mode. The power module is supplying power to the critical load.
	Off	The UPS is turned off.
  Yellow	On	The UPS is in Battery mode. Because Battery mode is a normal condition of the UPS, the Normal indicator also remains illuminated.
  Yellow	On	The UPS is in Bypass mode. The critical load is supported by the bypass source. The Normal indicator is not illuminated when the system is in Bypass mode.
  Red	On	The UPS has an active alarm and requires immediate attention. The LCD shows the highest priority active alarms. All alarms are accompanied by an audible horn. To silence the horn, press any control panel pushbutton once. The Alarm indicator may be illuminated along with other indicators.

Table 16. Status Indicators (Continued)

Indicator	Status	Description
	Flashing	There is a new UPS alarm condition. The indicator flashes until acknowledged by pressing any control panel pushbutton once.

7.2.2 System Events

When the UPS system is running in Normal mode, it continually monitors itself and the incoming utility power. In Battery or Bypass modes, the UPS may issue alarms to let you know exactly what event caused the change from Normal mode. System events on the UPS can be indicated by horns, lights, messages, or all three.

Select the **EVENTS** symbol from the menu bar on the main menu screen to display the active events screen. This screen shows any currently active alarms, notices, or commands. This screen shows any currently active alarms, notices, or commands. For more information on using the events screen, see paragraph [7.2.6 Display Menu Operation](#).

- **System Event Horns** – The system event horn beeps to alert an operator that an event needing attention is taking place. The horn cycles at a half-second rate.
- **System Event Indicators** – The status indicators on the UPS control panel work with the event horn to let the operator know when the UPS is operating in any mode other than normal. Only the Normal mode indicator is illuminated during normal UPS system operation. The other indicators illuminate to indicate alarms or events. When an alarm occurs, first check these indicators to see what type of event has taken place. For descriptions of the status indicators, see paragraph [7.2.1 Status Indicators](#).
- **System Event Messages** – When a system event occurs, a message appears on the LCD in the UPS status area. This message is also written to the Events Log and may be added to the History Log. The messages are divided into four categories: alarms, notices, status, and commands.

7.2.3 Using the LCD and Pushbuttons

The LCD on the control panel provides an operator interface with the UPS system. [Figure 41](#) identifies the display areas discussed in the following sections.

Figure 41. Parts of the LCD

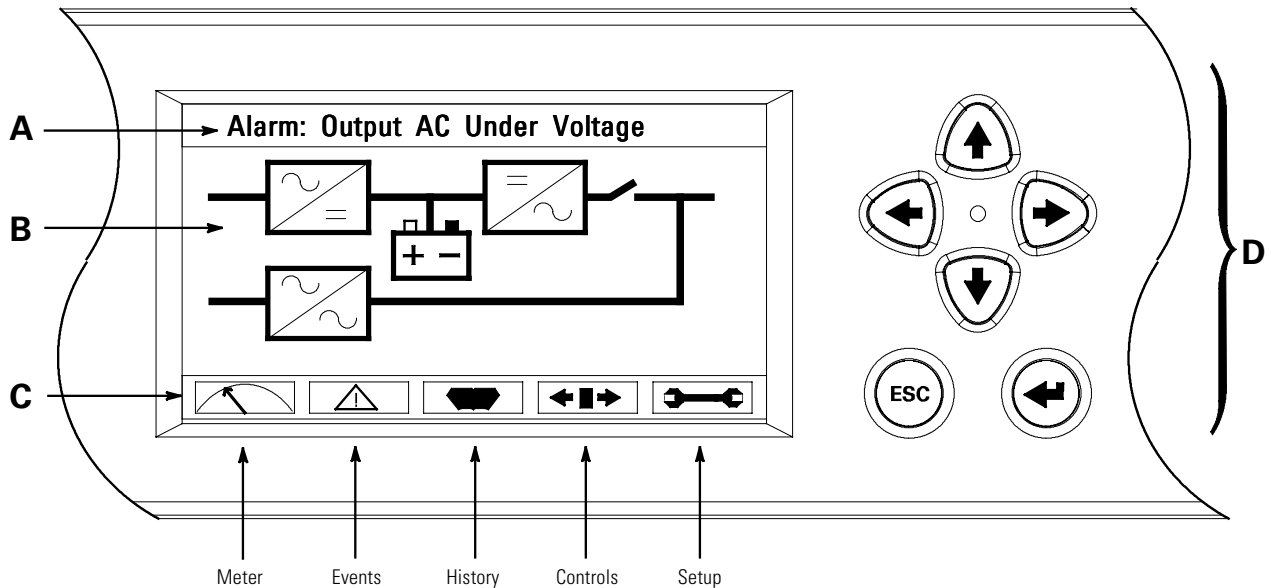

A The UPS status area automatically scrolls between the Eaton model number, current date and time, active alarms, UPS status, load percent, and battery runtime for the UPS. The top line of display blinks while scrolling when the system needs attention. Some notices and alarms may be accompanied by an audible horn. To silence the horn, press any control panel pushbutton once. Shown is a typical alarm message. For more information about alarms and notices, see paragraph [7.2.2 System Events](#).

B The information area contains data about UPS status and operations.

C The menu bar shows the symbols of the available screens. To select a screen, highlight the screen symbol using the navigation pushbuttons and then press the **RETURN** pushbutton.

D The navigation pushbuttons function depending on the screen displayed. Use the Up, Down, Left, and Right pushbuttons to scroll through available screens and the Esc and Enter pushbuttons to select menu screens and functions.

You can use the LCD and the pushbuttons to:



- Look at a log of UPS events (alarms, notices, and commands) (see paragraph [7.2.6 Display Menu Operation](#))
- Monitor UPS operation (see paragraph [7.2.6 Display Menu Operation](#))
- Set UPS parameters (see paragraph [7.2.6 Display Menu Operation](#))
- Control UPS operation (see paragraphs [7.2.6 Display Menu Operation](#) and [7.2.7 System Controls](#))

After approximately 10 minutes, the display screen darkens. To restore the screen, press any pushbutton once.

7.2.4 Using the Menu

The UPS menu bar allows you to display data in the information area to help you monitor and control UPS operation. [Table 17](#) shows the basic menu structure.

Table 17. Display Function Menu Map

Menu Option	Description
METERS	Displays performance meters for the system or critical load.
EVENTS	Displays the list of Active System Events.
HISTORY	Displays a historical log of system events.
CONTROLS	Displays the System Control screen.
SETUP	Allows you to set the date and time for the time stamp, set the display language, the unit name, and meter subscripts, change the password, and view the firmware version numbers.
ESC	Returns to Main Menu and Mimic screen from the Meters, Events, History, Controls, or Setup screens. Returns to the main System Setup Level screen from a setup submenu.
	Return arrow acknowledges or executes a command, or saves a setting.
	Up and down arrows scroll through screens and lists or highlight settings.
	Left and right arrows select or adjust settings displayed on the screen.

7.2.5 Mimic Screen

[Figure 42](#) shows the Main Menu and Mimic screen. To select the Mimic screen from the Meters, Events, History, Controls, or Setup screens, press the **ESC** pushbutton on the current menu bar.

The Mimic screen shows the internal components of the UPS cabinet and a real-time graphical representation of the operating status of the system.

Figure 42. Main Menu and Mimic Screen

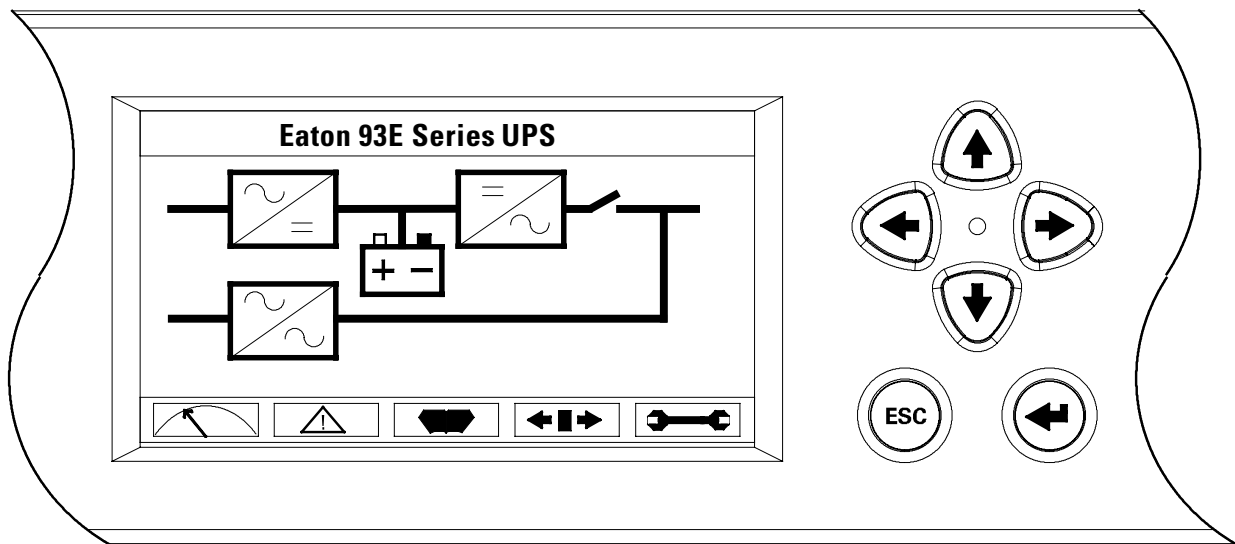

7.2.6 Display Menu Operation

[Table 18](#) describes the menu functions and how to use them.

Table 18. Display Menu Operation

Function	Subfunction	Operation
Meters – UPS		The Meter screens show the UPS meter readings for the unit. The default voltage displayed on these screens is phase-to-neutral. These can be changed to display the voltage phase-to-phase (A-B, B-C, C-A). Use the LEFT or RIGHT arrow pushbuttons to select the METER symbol on the main menu bar, to display the Meter screens. To scroll through the meter screens, press the UP or DOWN arrow pushbutton. The current UPS readings are displayed in the information area of the screen.
	Output – UPS	The Output screen shows output voltage (phase to neutral), output current (each phase), and frequency being supplied by the UPS, as well as the kVA, kW, and power factor measurements.
	Input – UPS	The Input screen shows input voltage (phase to neutral), input current (each phase), and frequency of the incoming utility source, as well as the kVA, kW, and power factor measurements.
	Bypass	The Bypass screen shows the bypass input voltage (phase to neutral), input current (each phase), and frequency of the incoming utility source, as well as the kVA, kW, and power factor measurements.
	Battery – UPS	The Battery screen displays the battery voltage (Vdc) and the battery current (Idc).
Events		Use the LEFT or RIGHT arrow pushbuttons to select the EVENTS symbol on the main menu bar to display the Events screens. A listing of all system events that are currently active is displayed. The most recent event is listed first. As events clear, they are removed from the Events listing. To scroll through the events, press the UP or DOWN arrow pushbutton.
History		Use the LEFT or RIGHT arrow pushbuttons to select the HISTORY symbol on the main menu bar to display the History screen. The history Log lists up to 512 events in chronological order, with the most recent event listed last (once 512 is reached, the earliest event is overwritten). The end of the log (the most recent events) is displayed first; scroll upward to view older event listings. To scroll through the events, press the UP or DOWN arrow pushbutton.
Setup – User	Function Selection	This screen can be used to display user information and show the firmware versions installed. Use the LEFT or RIGHT arrow pushbuttons to select the SETUP symbol on the main menu bar to display the Setup screen. Use the UP or DOWN arrow pushbutton to highlight the function desired, then press the RETURN pushbutton to display the function screen. See Figure 43 for a typical screen display.
	User Info	The User Info screen provides the model, CTO and serial numbers of the UPS, the Output voltage, frequency, and kVA rating, the input voltage rating, and the battery run time rating. Use the LEFT or RIGHT arrow pushbuttons to select USER on the Setup menu bar. Use the UP or DOWN arrow pushbutton. to select Info, then press the RETURN pushbutton to display the function screen. To return to the System Setup screen, press the ESC pushbutton.
	About	The About screen provides the firmware version numbers installed on the UPS. Use the LEFT or RIGHT arrow pushbuttons to select USER on the Setup menu

Table 18. Display Menu Operation (Continued)

Function	Subfunction	Operation
		bar. Use the UP or DOWN arrow pushbutton. to select About. To return to the System Setup screen, press the ESC pushbutton.
Setup – Config (System Level 1 Setup)	Password	To enter a password if required, use the LEFT or RIGHT arrow pushbutton to select the password character position. Use the UP or DOWN arrow pushbutton to change the password character. Once the password is entered, select DONE and then press the RETURN pushbutton. The System Setup Level 1 menu screen is displayed. The default System Setup Level 1 password is 0101.
	Function Selection	This screen can be used to set the date and time, change the display language, enter a unit name, change the meter style, perform lamp test, clear the history log, and enter a password to access Level 1 functions. Use the LEFT or RIGHT arrow pushbuttons to select the SETUP symbol on the main menu bar to display the Setup screen. Use the LEFT or RIGHT arrow pushbutton to select CONFIG on the Setup menu bar. Enter a password if required.
	Clock	The Clock Setup screen allows the selection of either month/day/year or day/month/year formats and daylight savings time for display on the screen and for logging events in the Event and History Logs. Use the UP or DOWN arrow pushbutton to select CLOCK to display the Clock screen. Use the UP or DOWN arrow pushbutton to highlight the desired format, then press the RETURN pushbutton to display the Set Date and Time screen. To return to the System Setup screen, press the ESC pushbutton.
Setup – Config (System Level 1 Setup) (continued)	Set Date and Time MM/DD/YYYY	The Set Date and Time MM/DD/YYYY screen allows the internal date and time of the UPS to be set in the month/day/year format. The date and time information is used for display on the screen and for logging events in the Event and History Logs. Use the LEFT or RIGHT arrow pushbutton to highlight the setting to be changed. Use the UP or DOWN arrow pushbutton to make the change. When finished making changes, use the LEFT or RIGHT arrow pushbutton to highlight SAVE and the UP or DOWN arrow pushbutton to select YES . To complete the save function and return to the System Setup screen, select the RETURN arrow pushbutton.
	Set Date and Time DD/MM/YYYY	The Set Date and Time DD/MM/YYYY screen allows the internal date and time of the UPS to be set in the day/month/year format. The date and time information is used for display on the screen and for logging events in the Event and History Logs. Use the LEFT or RIGHT arrow pushbutton to highlight the setting to be changed. Use the UP or DOWN arrow pushbutton to make the change. When finished making changes, use the LEFT or RIGHT arrow pushbutton to highlight SAVE and the UP or DOWN arrow pushbutton to select YES . To complete the save function and return to the System Setup screen, select the RETURN arrow pushbutton.
	Language	The Language Setup screen allows the display menu language to be selected. Use the UP or DOWN arrow pushbutton to highlight Language, then press the RETURN pushbutton to display the Language screen. Use the UP or DOWN arrow pushbutton to highlight the desired language, then press the RETURN pushbutton. To return to the System Setup screen, press the ESC pushbutton.
	Unit Name	The Unit Name Setup screen allows a unit name to be entered. Use the UP or DOWN arrow pushbutton to highlight Unit Name, then press the RETURN pushbutton to display the Unit Name screen. Use the LEFT or RIGHT arrow pushbutton to highlight the character to be changed. Use the UP or DOWN arrow pushbutton to make the change. When finished making changes, use the

Table 18. Display Menu Operation (Continued)

Function	Subfunction	Operation
		LEFT or RIGHT arrow pushbutton to highlight SAVE and the UP or DOWN arrow pushbutton to select YES . To complete the save function and return to the System Setup screen, select the RETURN arrow pushbutton. To return to the System Setup screen, press the ESC pushbutton.
	Meters	The Meters Setup screen allows the Meters Screen display style to be selected. Use the UP or DOWN arrow pushbutton to highlight Meters, then press the RETURN pushbutton to display the Meters screen. Use the UP or DOWN arrow pushbutton. to highlight the desired style, then press the RETURN pushbutton. To return to the System Setup screen, press the ESC pushbutton.
	Lamp Test	The Lamp Test screen allows the control panel status lamps to be tested. Use the UP or DOWN arrow pushbutton to highlight Lamp Test, then press the RETURN pushbutton to illuminate the status lamps. To return to the System Setup screen, press the ESC pushbutton.
	Clear Log	The Clear Log screen allows the history log to be cleared. Use the UP or DOWN arrow pushbutton to highlight Clear Log, then press the RETURN pushbutton to clear the log. To return to the System Setup screen, press the ESC pushbutton.
	P/W	The P/W screen is used to change the System Setup Level 1 password. Use the UP or DOWN arrow pushbutton to highlight P/W, then press the RETURN pushbutton to display the P/W screen. Use the LEFT or RIGHT arrow pushbutton to select the password character position. Use the UP or DOWN arrow pushbutton to change the password character. Once the password is entered, select CHANGE and then press the RETURN pushbutton.
Controls		See paragraph 7.2.7 System Controls for details.

Figure 43. Typical Initial Setup Screen

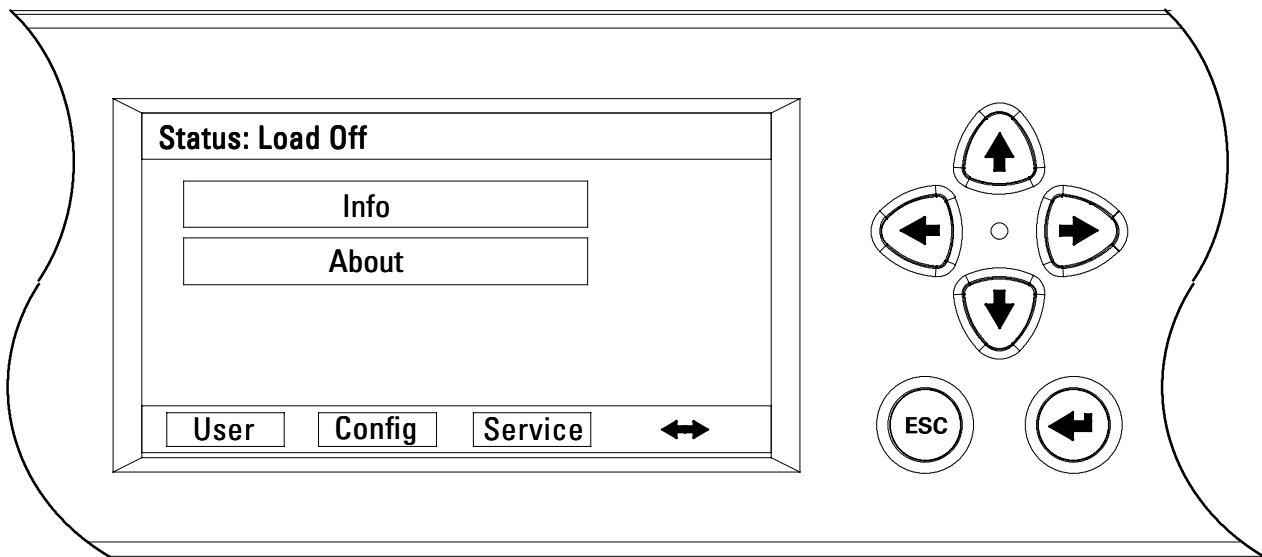

7.2.7 System Controls

Select the **CONTROLS** symbol on the main menu bar, then press the **RETURN** pushbutton to display the Controls screen. Normal operation, transfer to bypass, load off, and charger control commands are controlled through this screen. In addition, the screen displays the current status of the UPS. [Figure 44](#) shows the System Control screen.

Use the **↑** or **↓** pushbutton to highlight the command screen desired, then press the **RETURN** pushbutton to display the command menu screen.

Use the **←** or **→** pushbutton to highlight the command desired.

[Table 19](#) describes the control functions and provides instructions to access and use the command menu screens.

[Table 20](#) lists the typical System Status Screen Messages that are displayed during UPS operation.

For detailed information about using the System Controls, see paragraph [7.3 Single UPS Operation](#).

Figure 44. Typical System Control Screen

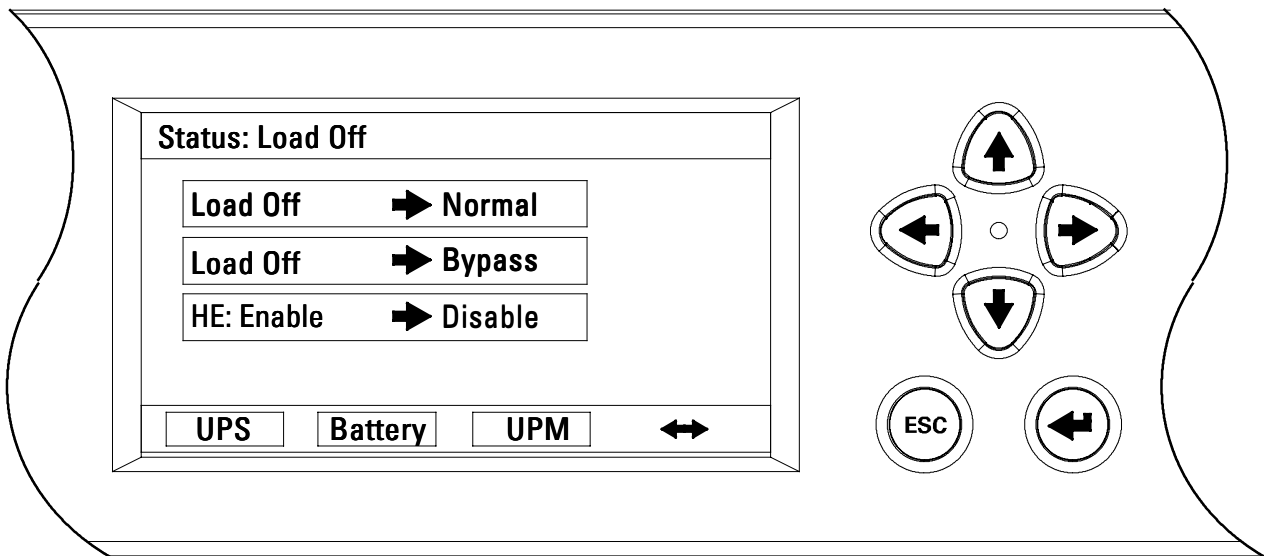

Table 19. Command Menu Operation

Function	Subfunction	Operation
UPS Control Commands		Use the up or down arrow pushbutton to highlight the command function desired, then press the RETURN pushbutton to execute the command or proceed to further command screens.
	Normal Mode	Starts the UPS in High Efficiency (HE) Normal mode or transfers the UPS to HE Normal mode from Bypass mode.
	Bypass Mode	Starts the UPS in Normal mode or transfers the UPS to Normal mode from Bypass mode.

Table 19. Command Menu Operation (Continued)

Function	Subfunction	Operation
	High-Efficiency (HE) Mode	Transfers the from HE Normal mode to Standard Normal mode. Transfers the from Standard Normal mode to HE Normal mode.
Battery Control Commands		Use the up or down arrow pushbutton to highlight the command function desired, then press the RETURN pushbutton to execute the command.
	Charger	Turns the battery charger on.
	Resting	Turns the battery charger off.

Table 20. Typical System Status Messages

Function	Message
UPS	Load Off; Bypass; Online, HE
Bypass	Off; On; Available
Charger	Charger Resting; Charger

7.3 Single UPS Operation

NOTE 1 If an External Battery Cabinet (EBC) is installed, refer to the *Eaton 93E External Battery Cabinet Installation Manual* listed in paragraph [1.7 For More Information](#) for EBC battery breaker location.

NOTE 2 If an Integrated Transformer Cabinet (ITC) is installed, refer to the *Eaton 93E Integrated Transformer Cabinet Installation Manual* listed in paragraph [1.7 For More Information](#) for ITC transformer breaker locations.



NOTE 3 If an Integrated Accessory Cabinet-Distribution (IAC-D) is installed, refer to the *Eaton 93E Integrated Accessory Cabinet-Distribution Installation and Operation Manual* listed in paragraph [1.7 For More Information](#) for operating instructions.

NOTE 4 If a Sidecar Integrated Accessory Cabinet-Bypass (SIAC-B) is installed, refer to the *Eaton 93E Sidecar Integrated Accessory Cabinet-Bypass Installation and Operation Manual* listed in paragraph [1.7 For More Information](#) for operating instructions.

7.3.1 Starting the UPS in High-Efficiency Normal Mode (Default Mode)

To start the UPS system:

1. Unfasten the front door by lifting the latch from the bottom and turning to the right (counterclockwise) and swing the door open (see [Figure 38](#)).
2. Verify that the input breaker is open.
3. If the UPS is EBC capable, verify that the UPS battery breaker is open.
4. Close the UPS input feeder circuit breaker.
5. If an ITC with an input transformer is installed, close the input and UPS input breakers.
6. If an ITC with an input and output transformer is installed, close the input, UPS input, and UPS output breakers.
7. If the UPS is dual-feed, close the bypass input feeder circuit breaker.

8. Close the input breaker.
9. If the UPS is EBC capable, close the UPS battery breaker.
10. Close the door and secure the latch.



NOTE

If two EBCs are installed, EBC 1 must be closed to supply DC input to the UPS. EBC 2 may be left open, but battery runtime will be reduced.

11. If EBCs are installed, close the EBC battery breakers.
12. Observe the UPS control panel display becoming active, indicating logic power.
13. Verify no alarms are active.
14. Select the **CONTROLS** symbol on the main menu bar. The System Control screen is displayed.
15. If not already selected, select UPS on the System Control screen.
16. On the UPS System Control screen, select the **LOAD OFF → NORMAL** command, then press the **RETURN** pushbutton.
17. If requested, enter the Level 1 password. Default password is 1111.

The rectifier and inverter turn on. The inverter continues to ramp up to full voltage.

Once the inverter reaches full voltage, the UPS inverter switchgear closes and the static switch turns off. Power is now supplied to the critical load in HE Normal mode. It takes approximately one minute for the UPS to achieve HE Normal mode.

The Normal status indicator is illuminated.

18. If an ITC with an input and output transformer is installed, close the output breaker.

7.3.2 Starting the UPS in Bypass Mode

If the inverter output of the UPS is not available and the critical load needs to be energized:



CAUTION

In Bypass mode, the critical load is not protected from commercial power interruptions and abnormalities.

1. Unfasten the front door by lifting the latch from the bottom and turning to the right (counterclockwise) and swing the door open ([Figure 38](#)).
2. Verify that the input breaker is open.
3. If the UPS is EBC capable, verify that the UPS battery breaker is open.
4. Close the UPS input feeder circuit breaker.
5. If an ITC with an input transformer is installed, close the input and UPS input breakers.
6. If an ITC with an input and output transformer is installed, close the input, UPS input, and UPS output breakers.
7. If the UPS is dual-feed, close the bypass input feeder circuit breaker.
8. Close the input breaker.
9. If the UPS is EBC capable, close the UPS battery breaker.
10. Close the door and secure the latch.



NOTE

If two EBCs are installed, EBC 1 must be closed to supply DC input to the UPS. EBC 2 may be left open, but battery runtime will be reduced.

11. If EBCs are installed, close the EBC battery breakers.
12. Observe the UPS control panel display becoming active, indicating logic power.
13. Verify no alarms are active.
14. Select the **CONTROLS** symbol on the main menu bar. The System Control screen is displayed.
15. If not already selected, select UPS on the System Control screen.
16. On the UPS System Control screen, select the **LOAD OFF → BYPASS** command, then press the **RETURN** pushbutton.
The critical load is immediately supplied by the bypass source, in Bypass mode.
The **BYPASS** status indicator is illuminated.
17. If an ITC with an input and output transformer is installed, close the output breaker.
The critical load is immediately supplied by the bypass source, in Bypass mode.

7.3.3 Transfer from Normal to Bypass Mode

To transfer the critical load to Bypass mode:



In Bypass mode, the critical load is not protected from commercial power interruptions and abnormalities.

1. Select the **CONTROLS** symbol on the main menu bar. The System Control screen is displayed.
2. If not already selected, select UPS on the System Control screen.
3. On the UPS System Control screen, select the **NORMAL → BYPASS** command, then press the **RETURN** pushbutton.
The UPS transfers to Bypass mode.
The **BYPASS** status indicator is illuminated. The power module remains on.



Power is present inside the UPS cabinet.

7.3.4 Transfer from Bypass to Normal Mode

To transfer the critical load to Normal mode:

1. Select the **CONTROLS** symbol on the main menu bar. The System Control screen is displayed.
2. If not already selected, select UPS on the System Control screen.
3. On the UPS System Control screen, select the **BYPASS → NORMAL** command, then press the **RETURN** pushbutton.
The UPS transfers to Normal mode. If the power module is not available, the system remains on bypass and an alarm sounds.
The **NORMAL** status indicator is illuminated.

7.3.5 Transfer from HE Normal Mode to Standard Normal Mode

To transfer the load to Standard Normal mode:

1. Select the **CONTROLS** symbol on the main menu bar. The System Control screen is displayed.

2. If not already selected, select UPS on the System Control screen.
3. On the UPS System Control screen, select the **HE: ENABLE → DISABLE** command, then press the **RETURN** pushbutton.

The UPS transfers to Standard Normal mode.

The **NORMAL** status indicator is illuminated.

7.3.6 Transfer from Standard Normal Mode to HE Normal mode

To transfer the load to HE Normal mode:

1. Select the **CONTROLS** symbol on the main menu bar. The System Control screen is displayed.
2. If not already selected, select UPS on the System Control screen.
3. On the UPS System Control screen, select the **HE: DISABLE → ENABLE** command, then press the **RETURN** pushbutton.

The UPS transfers to HE Normal mode if no abnormal power conditions are detected. If abnormal power conditions are detected, the UPS will wait and transfer to HE mode when conditions are cleared.

The **NORMAL** status indicator is illuminated.

7.3.7 UPS and Critical Load Shutdown

To perform maintenance or service on the critical load, shut down power to the load:

1. Turn off all equipment that is being powered by the UPS.
2. Perform the LOAD OFF procedure in paragraph [7.3.10 Using the UPS LOAD OFF Command](#).
3. Perform the battery charger off procedure in paragraph [7.3.8 Charger Control](#).

The inverter and bypass switchgear open, and the power module is turned off.

The rectifier and battery switchgear open.



Power is present inside the UPS cabinet after the upstream input feeder circuit breakers are opened because of the installed internal batteries.

4. Open the UPS input circuit breaker.
5. Open the UPS input feeder circuit breakers.
6. If the UPS is dual-feed, open the bypass feeder circuit breakers.
7. If the UPS is EBC capable, open the UPS battery breaker.
8. If EBCs are installed, open all EBC battery breakers.

7.3.8 Charger Control

To turn the battery charger on:

1. Select the **CONTROLS** symbol on the main menu bar. The System Control screen is displayed.
2. Select Battery on the System Control screen.
3. On the Battery System Control screen, select the **RESTING → CHARGING** command, then press the **RETURN** pushbutton.

To turn the battery charger off:

1. Select the **CONTROLS** symbol on the main menu bar. The System Control screen is displayed.
2. Select Battery on the System Control screen.
3. On the Battery System Control screen, select the **CHARGING → RESTING** command, then press the **RETURN** pushbutton.

7.3.9 Battery Test

NOTE 1 This UPS has a user initiated battery test intended to determine if the batteries are able to support the load.



NOTE 2 The battery test is only able to be initiated when the battery is fully charged. This normally occurs within 72 hours of the start of a charging cycle. The command will not be shown if the test is not able to be run.

To start the battery test:

1. Select the **CONTROLS** symbol on the main menu bar. The System Control screen is displayed.
2. Select Battery on the System Control screen.
3. On the Battery System Control screen, select the **RESTING → TESTING** command, then press the **RETURN** pushbutton.

7.3.10 Using the UPS LOAD OFF Command

A UPS Load Off is initiated by the Load Off command on the UPS Control screen. The UPS **LOAD OFF** controls the UPS output by powering down the UPS and de-energizing the critical load.

The UPS (including Bypass) remains off until restarted.

To use the **LOAD OFF** command:

1. Select the **CONTROLS** symbol on the main menu bar. The System Control screen is displayed.
2. Select UPS on the System Control screen.
3. On the UPS System Control screen, select the **NORMAL → LOAD OFF** or **BYPASS → LOAD OFF** command depending on the UPS mode, then press the **RETURN** pushbutton.

The Verify Action screen is displayed, providing a choice to proceed or abort the shutdown.



CAUTION

All power to the critical load is lost when the LOAD OFF is selected in the following step. You should use this feature only when you want to de-energize the critical load.

4. Select Yes or no, then press the **RETURN** pushbutton.
Selecting Yes will immediately shut down the UPS and de-energize the critical load. Selecting No will abort the shutdown.



CAUTION

Do not attempt to restart the system after Load Off until the cause of the shutdown has been identified and cleared.

5. To restart the UPS after pressing the **LOAD OFF** pushbutton, follow the procedure in paragraph [7.3.1 Starting the UPS in High-Efficiency Normal Mode \(Default Mode\)](#) or [7.3.2 Starting the UPS in Bypass Mode](#).

 **WARNING**

Power is present inside the UPS cabinet after the upstream input feeder circuit breakers are opened because of the installed internal batteries.

7.3.11 Using the Remote Emergency Power-off Switch

A UPS emergency power-off is initiated by the REPO pushbutton switch. In an emergency, you can use this switch to control the UPS output. The REPO switch de-energizes the critical load and powers down the UPS immediately, without asking for verification.

The UPS, including Bypass, remains off until restarted.

 **CAUTION**

All power to the critical load is lost when the REPO switch is activated in the following step. You should use this feature only when you want to de-energize the critical load.

**NOTE**

The following instructions are for the Eaton-supplied REPO switch. If a customer-supplied REPO switch is used, it may not activate in the same manner; refer to the operating instructions provided with the switch.

To use the REPO switch:

1. Firmly push the red pushbutton until it locks into place. The switch latches into the activated state (see [Figure 45](#)).

The rectifier, inverter, battery, and bypass switchgear open, and the power module is turned off immediately, without asking for verification.

 **CAUTION**

Do not attempt to restart the system after the REPO until the cause of the shutdown has been identified and cleared.

2. To deactivate the REPO switch in preparation for restarting the UPS, insert the supplied key and rotate clockwise until the red pushbutton releases (see [Figure 45](#)). To remove the key, rotate the key back to the vertical position.
 3. Restart the UPS by following the procedure in paragraph [7.3.1 Starting the UPS in High-Efficiency Normal Mode \(Default Mode\)](#) or [7.3.2 Starting the UPS in Bypass Mode](#).
-

 **WARNING**

Power is present inside the UPS cabinet after the upstream input feeder circuit breakers are opened because of the installed internal batteries.

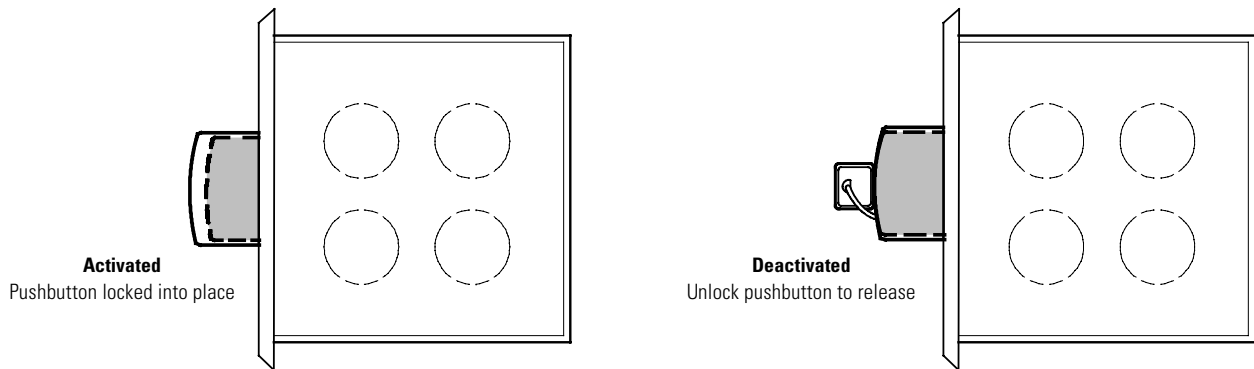
Figure 45. REPO Operation

7.4 Multiple UPS Parallel Operation

The paragraphs in this section provide operating instructions for a UPS system containing multiple UPSs.

-
- NOTE 1** If an External Battery Cabinet (EBC) is installed, refer to the Eaton 93E External Battery Cabinet Installation Manual listed in paragraph [1.7 For More Information](#) for EBC battery breaker location.
- NOTE 2** If an Integrated Accessory Cabinet-Tie (IAC-T) is installed, refer to the Eaton 93E Integrated Accessory Cabinet-Tie and Bypass Installation and Operation Manual listed in paragraph [1.7 For More Information](#) for operating instructions.
- i NOTE 3** If an Integrated Accessory Cabinet-Tie and Bypass is installed, refer to the Eaton 93E Integrated Accessory Cabinet-Tie and Bypass Installation and Operation Manual listed in paragraph [1.7 For More Information](#) for operating instructions.
- NOTE 4** If an Integrated Accessory Cabinet-Distribution (IAC-D) is installed, refer to the Eaton 93E Integrated Accessory Cabinet-Distribution Installation and Operation Manual listed in paragraph [1.7 For More Information](#) for operating instructions.
- NOTE 5** Start and control system wide functions from UPS 1.
-

7.4.1 Starting the Parallel UPS in High-Efficiency Normal Mode (Default Mode)

To start the UPS system:

1. Unfasten the front door by lifting the latch from the bottom and turning to the right (counterclockwise) and swing the door open (see [Figure 38](#)).
2. Verify that all input breakers are open.
3. If the UPSs are EBC capable, verify that all UPS battery breakers are open.
4. Close all Module Output Breakers (MOBs).
5. Close all UPS input feeder circuit breakers.
6. If the UPSs are dual-feed, close all bypass input feeder circuit breakers.
7. Close all input breakers.
8. If the UPSs are EBC capable, close all UPS battery breakers.

9. Close the door and secure the latch.



NOTE

For each UPS, if two EBCs are installed, EBC 1 must be closed to supply DC input to the UPS. EBC 2 may be left open, but battery runtime will be reduced.

10. If EBCs are installed, close all battery breakers.
11. Observe the UPS control panel displays becoming active, indicating logic power.
12. Verify no alarms are active.
13. Select the **CONTROLS** symbol on the main menu bar. The System Control screen is displayed.
14. If not already selected, select UPS on the System Control screen.
15. On the UPS System Control screen, select the **LOAD OFF → NORMAL** command, then press the **RETURN** pushbutton.
16. If requested, enter the Level 1 password. Default password is 1111.

All rectifiers and inverters turn on. The inverters continue to ramp up to full voltage.

Once all inverters reaches full voltage, the UPS inverter switchgear closes and the static switches turns off. Power is now supplied to the critical load in HE Normal mode. It takes approximately one minute for the UPS to achieve HE Normal mode.

The Normal status indicator is illuminated.

7.4.2 Starting the Parallel UPS in Bypass Mode

If the inverter output of the parallel UPS system is not available and the critical load needs to be energized:



CAUTION

In Bypass mode, the critical load is not protected from commercial power interruptions and abnormalities.

1. Unfasten the front door by lifting the latch from the bottom and turning to the right (counterclockwise) and swing the door open ([Figure 38](#)).
2. Verify that all input breakers are open.
3. If the UPSs are EBC capable, verify that all UPS battery breakers are open.
4. Close all Module Output Breakers (MOBs)
5. Close all UPS input feeder circuit breakers.
6. If the UPSs are dual-feed, close all bypass input feeder circuit breakers.
7. Close all input breakers.
8. If the UPSs are EBC capable, close all UPS battery breakers.
9. Close the door and secure the latch.



NOTE

For each UPS, if two EBCs are installed, EBC 1 must be closed to supply DC input to the UPS. EBC 2 may be left open, but battery runtime will be reduced.

10. If EBCs are installed, close all battery breakers.
11. Observe the UPS control panel displays becoming active, indicating logic power.
12. Verify no alarms are active.
13. Select the **CONTROLS** symbol on the main menu bar. The System Control screen is displayed.

14. If not already selected, select UPS on the System Control screen.
15. On the UPS System Control screen, select the **LOAD OFF → BYPASS** command, then press the **RETURN** pushbutton.

The critical load is immediately supplied by the bypass source, in Bypass mode from all UPSs.

The **BYPASS** status indicator is illuminated.

7.4.3 Transfer from Normal to Bypass Mode

To transfer the critical load to Bypass mode:



CAUTION

In Bypass mode, the critical load is not protected from commercial power interruptions and abnormalities.

1. Select the **CONTROLS** symbol on the main menu bar. The System Control screen is displayed.
2. If not already selected, select UPS on the System Control screen.
3. On the UPS System Control screen, select the **NORMAL → BYPASS** command, then press the **RETURN** pushbutton.

All of the UPSs transfer to Bypass mode.

The **BYPASS** status indicator is illuminated. The power module remains on.



WARNING

Power is present inside the UPS cabinet.

7.4.4 Transfer from Bypass to Normal Mode

To transfer the critical load to Normal mode:

1. Select the **CONTROLS** symbol on the main menu bar. The System Control screen is displayed.
2. If not already selected, select UPS on the System Control screen.
3. On the UPS System Control screen, select the **BYPASS → NORMAL** command, then press the **RETURN** pushbutton.

All of the UPSs transfer to Normal mode. If the power module is not available, the system remains on bypass and an alarm sounds.

The **NORMAL** status indicator is illuminated.

7.4.5 Transfer from HE Normal Mode to Standard Normal Mode

To transfer the load to Standard Normal mode:

1. Select the **CONTROLS** symbol on the main menu bar. The System Control screen is displayed.
2. If not already selected, select UPS on the System Control screen.
3. On the UPS System Control screen, select the **HE: ENABLE → DISABLE** command, then press the **RETURN** pushbutton.

All of the UPSs transfer to Standard Normal mode.

The **NORMAL** status indicator is illuminated.

7.4.6 Transfer from Standard Normal Mode to HE Normal mode

To transfer the load to HE Normal mode:

1. Select the **CONTROLS** symbol on the main menu bar. The System Control screen is displayed.
2. If not already selected, select UPS on the System Control screen.
3. On the UPS System Control screen, select the **HE: DISABLE → ENABLE** command, then press the **RETURN** pushbutton.

All of the UPSs transfer to HE Normal mode if no abnormal power conditions are detected. If abnormal power conditions are detected, the UPSs will wait and transfer to HE mode when conditions are cleared.

The **NORMAL** status indicator is illuminated.

7.4.7 Single UPS Shutdown

To shut down a single UPS:

1. Open the MOB for the UPS being shut down.
2. Select the **CONTROLS** symbol on the main menu bar. The System Control screen is displayed.
3. If not already selected, select UPS on the System Control screen.
4. On the UPS System Control screen, select the **NORMAL → UPS OFF** command, then press the **RETURN** pushbutton.

The inverter and bypass switchgear open, and the power module is turned off on the UPS being shut down.

Logic power remains on.



WARNING

Power is present inside the UPS cabinet until the upstream input feeder circuit breaker is opened.

5. Open the UPS input feeder circuit breaker for the UPS being shut down.
6. If the UPS is dual-feed, open the bypass feeder circuit breaker for the UPS being shut down.
7. If the UPS is EBC capable, open the UPS battery breaker.
8. If EBCs are installed, open all battery breakers

The UPS is now completely shut down.

7.4.8 Single UPS Restart

To restart a single UPS from a shutdown state:

1. Close the MOB for the UPS being restarted.
2. Close the UPS input feeder circuit breaker for the UPS being restarted.
3. If the UPS is dual-feed, close the bypass feeder circuit breaker for the UPS being restarted.
4. Close the input breaker.
5. If the UPS is EBC capable, close the UPS battery breaker.
6. If EBCs are installed, close the battery breakers.
7. On the UPS being restarted, observe the UPS control panel display becoming active, indicating logic power.
8. Verify no alarms are active on the UPS being restarted.

9. On the UPS being restarted, select the **CONTROLS** symbol on the main menu bar. The System Control screen is displayed.
10. If not already selected, select UPS on the System Control screen.
11. On the UPS System Control screen, select the **UPS OFF → NORMAL** command, then press the **RETURN** pushbutton.
12. If requested, enter the Level 1 password. Default password is 1111.

The rectifier and inverter turn on. The inverter continues to ramp up to full voltage.

Once the inverter reaches full voltage, the UPS inverter switchgear closes and the static switch turns off. Power is now supplied to the critical load in HE Normal mode along with the other UPSs online. It takes approximately one minute for the UPS to achieve HE Normal mode.

The Normal status indicator is illuminated.

7.4.9 UPS and Critical Load Shutdown

To perform maintenance or service on the critical load, shut down power to the load:

1. Turn off all equipment that is being powered by the UPS parallel system.
2. Transfer the UPSs to bypass by performing the procedure in paragraph [7.4.3 Transfer from Normal to Bypass Mode](#).
3. Perform the LOAD OFF procedure in paragraph [7.4.12 Using the UPS LOAD OFF Command](#).

The inverter and bypass switchgear open, and the power module is turned off.

4. Perform the battery charger off procedure in paragraph [7.4.10 Charger Control](#) for each UPS.

The rectifier and battery switchgear open.



WARNING

Power is present inside the UPS cabinets after the upstream input feeder circuit breakers are opened because of the installed internal batteries.

5. Open all of the UPS input circuit breakers.
6. Open all of the MOBs.
7. Open all UPSs input feeder circuit breakers.
8. If the UPSs are dual-feed, open all bypass feeder circuit breakers.
9. If the UPSs are EBC capable, open all UPSs battery breakers.
10. If EBCs are installed, open all battery breakers

7.4.10 Charger Control

To turn an individual UPS battery charger on:

1. Select the **CONTROLS** symbol on the main menu bar on the UPS requiring the charger to be turned on. The System Control screen is displayed.
2. Select Battery on the System Control screen.
3. On the Battery System Control screen, select the **RESTING → CHARGING** command, then press the **RETURN** pushbutton.

To turn an individual UPS battery charger off:

1. Select the **CONTROLS** symbol on the main menu bar on the UPS requiring the charger to be turned off. The System Control screen is displayed.
2. Select Battery on the System Control screen.
3. On the Battery System Control screen, select the **CHARGING → RESTING** command, then press the **RETURN** pushbutton.

7.4.11 Battery Test

NOTE 1 This UPS has a user initiated battery test intended to determine if the batteries are able to support the load.



NOTE 2 The battery test is only able to be initiated when the battery is fully charged. This normally occurs within 72 hours of the start of a charging cycle. The command will not be shown if the test is not able to be run.

To start an individual UPS battery test:

1. Select the **CONTROLS** symbol on the main menu bar on the UPS to be tested. The System Control screen is displayed.
2. Select Battery on the System Control screen.
3. On the Battery System Control screen, select the **RESTING → TESTING** command, then press the **RETURN** pushbutton.

7.4.12 Using the UPS LOAD OFF Command

A UPS Load Off is initiated by the Load Off command on the UPS Control screen. The UPS **LOAD OFF** controls the UPSs output by powering down the UPS and de-energizing the critical load.

The UPSs (including Bypass) remains off until restarted.

To use the **LOAD OFF** command:

1. Select the **CONTROLS** symbol on the main menu bar on the UPS to be shut down. The System Control screen is displayed.
2. Select UPS on the System Control screen.
3. On the UPS System Control screen, select the **NORMAL → LOAD OFF** or **BYPASS → LOAD OFF** command depending on the UPS mode, then press the **RETURN** pushbutton.

The Verify Action screen is displayed, providing a choice to proceed or abort the shutdown.

CAUTION

All power to the critical load is lost when the LOAD OFF is selected in the following step. You should use this feature only when you want to de-energize the critical load.

4. Select Yes or no, then press the **RETURN** pushbutton.
 Selecting Yes will immediately shut down the UPS and de-energize the critical load. Selecting No will abort the shutdown.
5. If another UPS is to be shut down, proceed to that UPS and repeat [Step 1](#) through [Step 4](#).

CAUTION

Do not attempt to restart the system after Load Off until the cause of the shutdown has been identified and cleared.

6. To restart the UPS after pressing the **LOAD OFF** pushbutton, follow the procedure in paragraph [7.4.1 Starting the Parallel UPS in High-Efficiency Normal Mode \(Default Mode\)](#) or [7.4.2 Starting the Parallel UPS in Bypass Mode](#).

**WARNING**

Power is present inside the UPS cabinet after the upstream input feeder circuit breakers are opened because of the installed internal batteries.

7.4.13 Using the Remote Emergency Power-off Switch

A UPS emergency power-off is initiated by the REPO pushbutton switch. In an emergency, you can use this switch to control the UPS output. The REPO switch de-energizes the critical load and powers down the UPSs immediately, without asking for verification.

The UPSs, including Bypass, remains off until restarted.

**CAUTION**

All power to the critical load is lost when the REPO switch is activated in the following step. You should use this feature only when you want to de-energize the critical load.

**NOTE**

The following instructions are for the Eaton-supplied REPO switch. If a customer-supplied REPO switch is used, it may not activate in the same manner; refer to the operating instructions provided with the switch.

To use the REPO switch:

1. Firmly push the red pushbutton until it locks into place. The switch latches into the activated state (see [Figure 45](#)).

The rectifier, inverter, battery, and bypass switchgear open, and the power module is turned off immediately, without asking for verification.

**CAUTION**

Do not attempt to restart the system after the REPO until the cause of the shutdown has been identified and cleared.

2. To deactivate the REPO switch in preparation for restarting the UPS, insert the supplied key and rotate clockwise until the red pushbutton releases (see [Figure 45](#)). To remove the key, rotate the key back to the vertical position.
3. Restart the UPS by following the procedure in paragraph [7.4.1 Starting the Parallel UPS in High-Efficiency Normal Mode \(Default Mode\)](#) or [7.4.2 Starting the Parallel UPS in Bypass Mode](#).

**WARNING**

Power is present inside the UPS cabinet after the upstream input feeder circuit breakers are opened because of the installed internal batteries.

Chapter 8 Communication

This chapter describes the communication features of the Eaton 93E UPS.

8.1 Mini-Slot Cards

The Eaton 93E UPS has two standard, factory-installed Mini-Slot communication bays. The UPS is compatible with the following Mini-Slot cards (see [Figure 46](#)):

Network Cards:

**NOTE**

Only one of the four following network cards can be used for network connectivity at one time.

- Eaton Gigabit Network Card (NETWORK-M2) – Eaton’s latest UPS connectivity device that delivers better speed and cybersecurity, the Gigabit Network Card improves business continuity in two ways: by providing warnings of pending issues to administrators and helping to perform orderly shutdown of servers and storage.
- Eaton Industrial Gateway Card (INDGW-M2) – combines the features of an SNMP agent, HTTP/web server and a Modbus card to facilitate remote monitoring of your UPS system through any Building Management System. Enjoy the freedom to customize and schedule actions, like shutdown protocols and load shedding, and receive immediate notifications during power events, without having to be onsite.
- Modbus-MS Card (MODBUS-MS) – provides remote monitoring through a Web browser interface, e-mail, and a network management system (NMS) using SNMP and connects to a twisted-pair Ethernet (10/100BaseT) network. The card also provides direct integration of UPS information (meters and status) to a Building Management System (BMS) using the Modbus RTU protocol.
- Network Management Card (NETWORK-MS) – provides remote monitoring through a Web browser interface, e-mail, and a network management system (NMS) using SNMP and connects to a twisted-pair Ethernet (10/100BaseT) network.

Relay Cards:

- Relay Card-MS (RELAY-MS) – contains two types of interfaces via a DB9 connector are available with this card. Dry contact mode provides a simple way to transmit UPS information to an alarm system, PLC, or computer system via dry relay contacts. Normal, Bypass, Battery, and Alarm modes can be monitored. See [Table 21](#) for default triggers. RS232 mode provides an RS232 interface for connection to a PC or to a UPS Control display unit. Jumpers are used to select the interface (contacts or RS232).
- Industrial Relay Card-Minislot (INDRELAY-MS) – can be used to indicate the operating status of the UPS system using the customer’s monitoring equipment. The Industrial Relay Card uses five isolated normally-open or normally-closed dry relay contacts to indicate the UPS status. Normal, Bypass, Battery, and Alarm modes can be monitored. See [Table 21](#) for default triggers. The contact ratings and wire range are listed in the IRC-MS installation guide. One input can be activated by a switch or dry contact. The voltage source is provided by the card, no external voltage source is needed.

LAN and telephone drops for use with Mini-Slot connectivity cards must be supplied by facility planners or the customer.

**NOTE**

For installation, setup, and operation of a Mini-Slot card, refer to the instructions supplied with the Mini-Slot card. For additional assistance, contact an Eaton service representative.

Figure 46. Optional Mini-Slot Cards

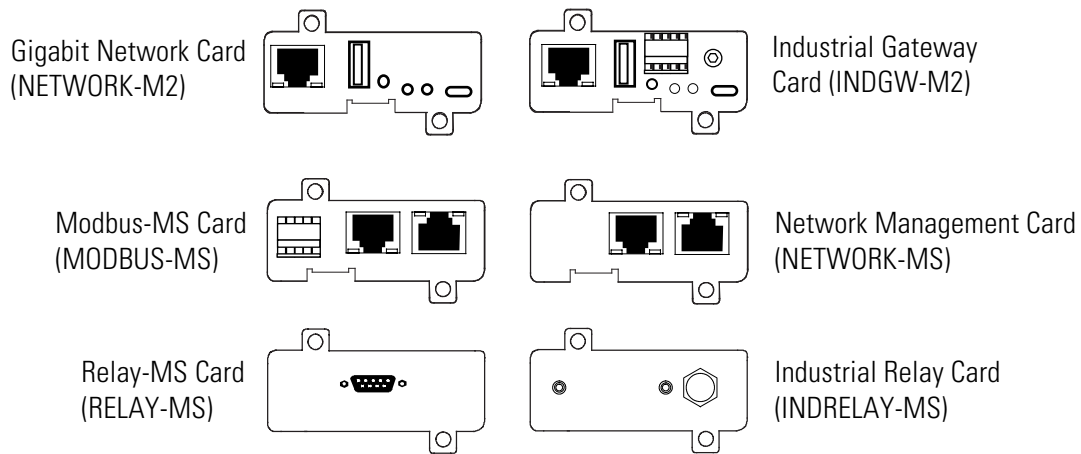

Table 21. Relay Card-MS and Industrial Relay Card IRC-MS Default Triggers

UPS Alarm	Relay	Trigger	Indicator
On Normal	K1	UPS supporting the load	Normal indicator is illuminated
On Battery	K2	UPS on Battery	Battery indicator is illuminated
Alarm	K3	Summary alarm / Active Alarms	Alarm indicator is illuminated
On Bypass	K4	UPS on bypass	Bypass indicator is illuminated
Battery Low	K5	UPS battery voltage level below the low voltage threshold	Low Battery warning is active

NOTE Each relay connection has a NO and NC contact and an isolated relay

8.2 XCP Communication Ports

The USB port and the RS-232 (DB9) port, both located behind the control panel, are used for XCP communication. The ports are accessed by opening the UPS door, see [Figure 47](#) for port location.

Figure 47. XCP Communication Ports

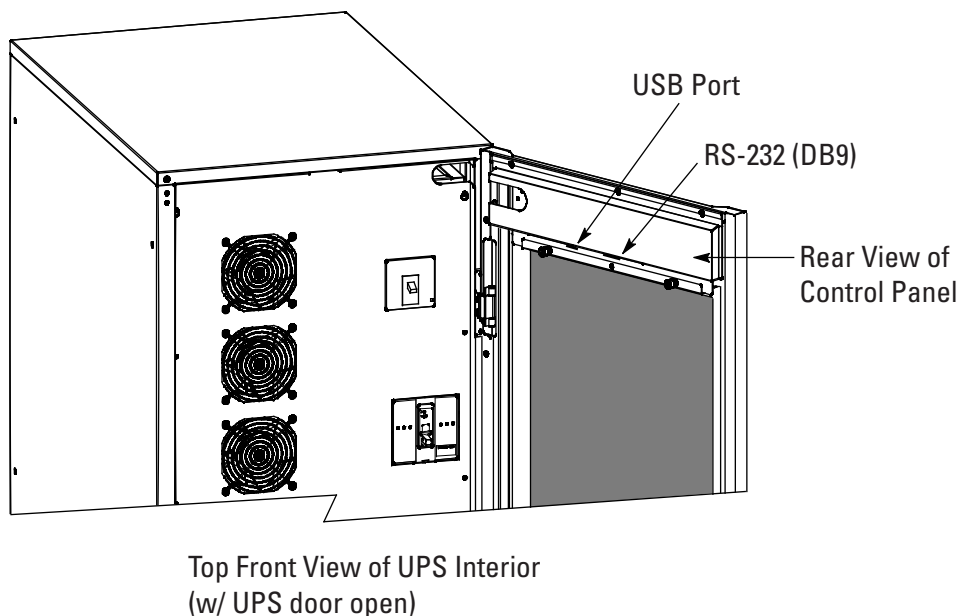

8.3 Building Alarm Monitoring

This standard feature lets you connect the UPS to your building alarms, such as smoke detectors or overtemperature alarms. The customer interface terminals for external connections are located inside the UPS. Use twisted-pair wires for each alarm input and common.

The building alarms can be programmed to display the alarm functional name.

8.4 Predict Pulse Remote Monitoring and Management Service

The Eaton 93E UPS supports Eaton's PredictPulse remote monitoring and management service. PredictPulse is a subscription monitoring and management service that collects and analyzes data from connected power infrastructure devices, providing us with the insight needed to make recommendations and take action on your behalf. It's also powered by CA Technologies, bringing together the best in hardware and software. PredictPulse Service is included at no charge during the first year of Eaton 93E UPS operation (warranty period) along with the required connectivity parts. Beyond that, it may be purchased with Eaton Support Agreements or as a standalone subscription after the initial warranty expires. PredictPulse may also be subscribed to for free as part of a 90-day trial period. PredictPulse availability and first year bundled offers may vary by market. For more information, visit www.eaton.com/predictpulse.

8.4.1 PredictPulse Service Features

PredictPulse provides proactive monitoring, an online dashboard, mobile app with alarm status information and a monthly report detailing the ongoing health of your Eaton 93E UPS. Features include:

- Proactive monitoring that automatically analyzes the status of the Eaton 93E UPS 96 times every day (every 15 minutes). All health data gathered from the unit, current and historical, is analyzed at the

Customer Reliability Center (CRC). Algorithms and sophisticated analytics software is constantly scanning your UPS's data for potential failures. Anomalies are escalated to a Software and Monitoring analyst or Technical Support specialist. Critical events are remotely diagnosed to expedite repairs, including smart dispatch of field technicians with probable cause and likely parts (avoiding return visits due to lack of required parts). Through this service, the CRC can take pre-emptive, corrective action to ensure the highest level of availability of your Eaton 93E UPS.

- Easy self-installation in minutes from a wizard installer or directly from the PXGMS card. PredictPulse uses standard Eaton connectivity hardware, requiring no special software (devices only need to be connected to a network).
- Ability to give an unlimited number of coworkers access to the real-time data and reports found in PredictPulse's online dashboard and mobile app. This allows you to collaborate and Eaton to notify the most appropriate person responsible for a specific site or device.
- Real-time access to key performance information, alarms and trended health data about your Eaton 93E UPS via the PredictPulse online dashboard. Depending on the model, the dashboard aggregates all subscribed devices and provides detailed information about voltages, loads, energy savings, service levels, external factors such as temperature and humidity, attached batteries, and system availability. All of these factors contribute to the Relative Performance Index (RPI) score that allows you to compare your unit's health relative to Eaton's optimum UPS operating levels.
- Real-time alarm events for all subscribed devices via the PredictPulse mobile app (Apple and Android). You can track all alarms by device. As critical alarms occur, Eaton will acknowledge them so you know when Eaton has diagnosed the alarm (and pending notification of resolution).
- A monthly summary report that delivers key performance information, alarms and trended health data about your Eaton 93E UPS, based on the prior month's data.
- A foundation based on CA Technologies' leading Data Center Infrastructure Management (DCIM) software application. This enables powerful reporting, analytics, security, and compatibility with hundreds of power infrastructure devices.

8.4.2 Installing PredictPulse

A quick start guide and self-installation wizard tool are available at www.eaton.com/predictpulse. The latest updates, installation tips and information on connecting PredictPulse are also available at that link. For installation support or questions about PredictPulse, contact predictpulsesupport@eaton.com.

Chapter 9 UPS Maintenance

The components inside the UPS cabinet are secured to a sturdy metal frame. All repairable parts and assemblies are located for easy removal, with very little disassembly. This design allows authorized service personnel to perform routine maintenance and servicing quickly.

You must schedule periodic performance checks of your UPS system to keep it running properly. Regular routine checks of operation and system parameters enable your system to function efficiently for many trouble-free years.

9.1 Important Safety Instructions

Remember that your UPS system is designed to supply power **EVEN WHEN DISCONNECTED FROM THE UTILITY POWER**. The UPS module interiors are unsafe until the DC power source is disconnected and the electrolytic capacitors are discharged. After disconnecting the utility power and the DC power, authorized service personnel should wait at least five minutes for capacitor bleedoff before attempting internal access to the UPS module.



- Servicing and maintenance should be performed by qualified service personnel only.
- LETHAL VOLTAGE PRESENT. This unit should not be operated with the cabinet doors open or protective panels removed. Do not make any assumptions about the electrical state of any cabinet in the UPS system.

Each battery string is an energy source in itself. **DO NOT ATTEMPT TO ACCESS ANY INTERNAL AREA OF THE BATTERY STRING YOURSELF. VOLTAGES ARE ALWAYS PRESENT IN THE BATTERY STRING.** If you suspect that a battery string needs service, contact an Eaton service representative.

If the string requires service contact an Eaton service representative.

Observe these precautions when working on or around batteries:

- Remove watches, rings, or other metal objects.
- Use tools with insulated handles.
- Wear rubber gloves and boots.
- Do not lay tools or metal parts on top of batteries.
- Disconnect the charging source prior to connecting or disconnecting terminals.
- Determine if the battery is inadvertently grounded. If it is, remove the source of the ground. Contact with any part of a grounded battery can result in electrical shock. The likelihood of such shock is reduced if such grounds are removed during installation and maintenance.
- When replacing batteries, use the same number of sealed, lead-acid batteries.
- Proper disposal of batteries is required. Refer to your local codes for disposal requirements.
- Do not dispose of batteries in a fire. Batteries may explode when exposed to flame.
- Do not open or mutilate batteries. Released electrolyte is harmful to the skin and eyes. It may be toxic.

9.2 Performing Preventive Maintenance

The UPS system requires very little preventive maintenance. However, the system should be inspected periodically to verify that the units are operating normally and that the batteries are in good condition.

9.2.1 DAILY Maintenance

Perform the following steps daily:

1. Check the area surrounding the UPS system. Ensure the area is not cluttered, allowing free access to the unit.
2. Ensure the air intakes (vents on the front door of the UPS cabinet and the exhaust openings (on the rear of the UPS cabinet) are not blocked.
3. Ensure the operating environment is within the parameters specified in paragraph [3.2.1 Environmental and Installation Considerations](#) and [Chapter 10 Product Specifications](#).
4. Ensure the UPS is in Normal mode (Normal status indicator is illuminated). If an alarm lamp is illuminated or the Normal status indicator is not illuminated, contact an Eaton service representative.

9.2.2 MONTHLY Maintenance

Perform the following steps monthly:

1. Monitor system parameters as described in paragraph [7.2 Using the Control Panel](#).
2. Check the UPS air filters (located behind the front door) and wash or replace as necessary. See [Figure 48](#) for filter location. Contact an Eaton service representative for replacement filters.

To remove the filters:

 **CAUTION**

Verify washed filter is thoroughly dry before reinstalling.

- a. Unfasten the front door by lifting the latch from the bottom and turning to the right (counterclockwise) and swing the door open.
 - b. Loosen thumbscrews securing filter retaining brackets.
 - c. Remove the foam filter from the frame on the front door.
 - d. Replace the washed or new foam filter into the frame on the front door.
-

 **IMPORTANT**

The foam filters are to be replaced with new or washed filter immediately. The UPS is not meant to be run without filters installed.

- e. Secure filter retaining brackets with thumbscrews.
 - f. Close the front door and secure the latch.
3. Record maintenance results and any corrective actions in a suitable log.

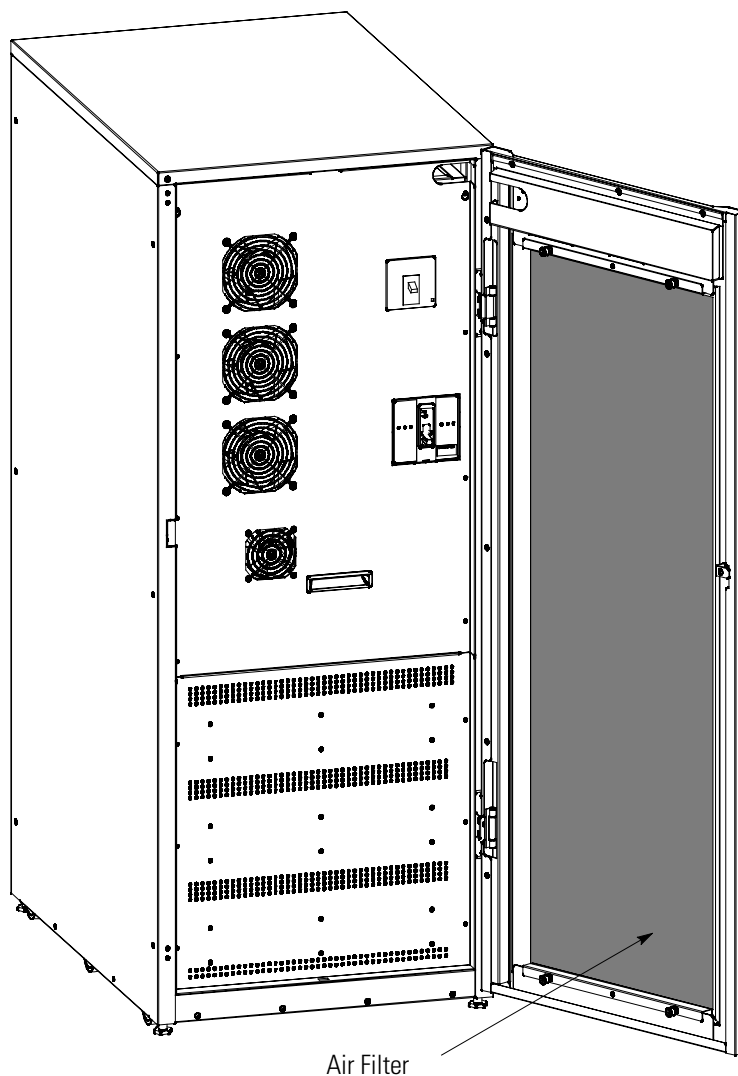
Figure 48. Air Filter Location

9.2.3 PERIODIC Maintenance

Periodic inspections of the UPS should be made to determine if components, wiring, and connections exhibit evidence of overheating. Particular attention should be given to the compression lug connections. Maintenance procedures should specify that the compression lug connections be retorqued to values listed in this manual.

9.2.4 ANNUAL Maintenance

Annual preventive maintenance should be performed only by authorized service personnel familiar with maintenance and servicing of the UPS system. Contact an Eaton service representative for more information about service offerings.

9.2.5 BATTERY Maintenance

Contact an Eaton service representative for battery maintenance. Battery replacement and maintenance should be performed only by authorized service personnel.

9.3 Installing Batteries

Install batteries in accordance with the battery and battery system manufacturer's instructions.

9.4 Recycling the Used Battery or UPS

Contact your local recycling or hazardous waste center for information on proper disposal of the used battery or UPS.



WARNING

- Do not dispose of the battery or batteries in a fire. Batteries may explode. Proper disposal of batteries is required. Refer to your local codes for disposal requirements.
- Do not open or mutilate the battery or batteries. Released electrolyte is harmful to the skin and eyes. It may be toxic.
- A battery can cause electrical shock, burn from high short-circuit current, or fire. Observe proper precautions.



ATTENTION!

- Une batterie peut présenter un risque de choc électrique, de brûlure, ou d'incendie. Suivre les précautions qui s'imposent.
- Pour le remplacement, utiliser le même nombre et modèle des batteries.
- L'élimination des batteries est réglementée. Consulter les codes locaux à cet effet.



CAUTION

Do not discard the UPS or the UPS batteries in the trash. This product contains sealed, lead-acid batteries and must be disposed of properly. For more information, contact your local recycling/reuse or hazardous waste center.



CAUTION

Do not discard waste electrical or electronic equipment (WEEE) in the trash. For proper disposal, contact your local recycling/reuse or hazardous waste center.

9.5 Maintenance Training

A basic training course, available from Eaton, gives you a competent working knowledge of the UPS system operation and teaches you how to perform first level corrective maintenance. For more information about training and other services, contact the Help Desk (see paragraph [1.8 Getting Help](#)).

Chapter 10 Product Specifications

10.1 Model Numbers

The UPS is housed in a free-standing cabinet with safety shields behind the door. The UPS is available in 50 or 60 Hz with various output power ratings.

Models	Power Rating	Frequency
Eaton 93E–20	20 kVA	50/60 Hz
Eaton 93E–30/20	20 kVA	50/60 Hz
Eaton 93E–30/30	30 kVA	50/60 Hz

10.2 Specifications

The following sections detail the input, output, environmental, and battery specifications for the UPS.

10.2.1 UPS Input

Operating Input Voltage	208/220 Vac
Operating Input Frequency Range	50/60 Hz
Operating Input Current	See Table 5 . Reduced for Generator Adjustable
Input Current Harmonic Content	5% THD at full load
Power Factor	Minimum 0.99
Line Surges	4 kV OC, 3 kA SC per ANSI 62.41 and IEC 801 4
Battery Voltage	216 Vdc
Battery Charging Capacity	Up to a maximum of 20A at any load up to 100% load (supports internal and internal plus external battery configurations)

10.2.2 UPS Output

UPS Output Capacity	100% rated current
Output Voltage Regulation	± 1% (10% to 100% load)
Nominal Output Voltage	208 Vac and 220 Vac nominal
Output Voltage Harmonic Content	2% maximum THD (linear load) 5% maximum THD (nonlinear load)
Output Current	See Table 5 .
Output Voltage Balance	< 2% for 100% maximum load imbalance (linear load)
Output Voltage Phase Displacement	< 2.5° for 100% maximum load imbalance (linear load)

Frequency Regulation	0.1 Hz free running
Synchronous to Bypass	± 4 Hz (default setting)
Frequency Slew Rate	3 Hz per second (default setting)
Load Compatibility	0.8 pF Leading 0.8 pF Lagging
Overload Capability	<110% for 10 minutes <125% for 30 seconds <150% for 150 milliseconds >150% for 40 milliseconds

10.2.3 UPS Environmental

Operating Temperature	0 to 30°C (32 to 86°F) without derating. The recommended operating temperature is 25°C (77°F).
Operating Altitude	Maximum 1500m (5000 ft) at 30°C without derating
Storage Temperature	-25 to +55°C, excluding batteries (prolonged storage above 40°C causes rapid battery self-discharge)
Relative Humidity (operating and storage)	5% to 95% maximum noncondensing
Acoustical Noise	Less than or equal to 57 dBA at a 1m distance, per ISO 7779
EMI Emissions and Immunity	Meets IEC 62040-2 C3 and FCC Part 15 Subpart B, ICES-003, CISPR 22, CISPR 24, and VCCI: Class A
Electrostatic Discharge (ESD) Immunity	Meets IEC 61000-4-5 Level 4 specifications. Withstands up to 4 kV pulse without damage and with no disturbance or adverse effect to the critical load.

10.2.4 UPS Internal Battery Runtimes (in Minutes) at Full load

UPS Model	UPS Rating	Number of UPS Battery Strings	Runtime
93E-20	20 kVA	4	12.0
93E-30/20	20 kVA	6	22.0
93E-30/30	30 kVA	6	12.0

NOTE Battery times are approximate and vary depending on the load configuration and battery charge.

10.2.5 UPS Internal Battery Plus External Battery Cabinet Runtimes (in Minutes) at Full load

UPS Model	UPS Rating	Number of UPS Battery Strings	EBC Model	Number of EBCs	Number of EBC Battery Strings	Runtime
93E-30/20	20 kVA	6	93E 30EBC	1	3	74.6
93E-30/20	20 kVA	6	93E 30EBC	2	6	138.0
93E-30/30	30 kVA	6	93E 30EBC	1	3	45.6
93E-30/30	30 kVA	6	93E 30EBC	2	6	84.5

NOTE Battery times are approximate and vary depending on the load configuration and battery charge.

Chapter 11 Warranty

For warranty information, please refer to the Resources link on our website, www.eaton.com/93E.

EQUIPMENT REGISTRATION

Please visit www.eaton.com/pg/register to register your new Eaton UPS / Eaton UPS Accessory.

Model Number:

Serial Number:



164000301 04