

DuraRac[®]

Rear DuraRac Installation Instructions

Nissan NV1500/2500/3500 - Low/High Roof

Frame Kit Part #: CRC 05-1000-002

V1.0.12.03.18



IMPORTANT INSTALLATION STEPS ARE DENOTED USING A STOP SIGN. THESE STEPS MUST BE PERFORMED IN THE SPECIFIED ORDER TO ENSURE PROPER INSTALLATION AND MUST BE FOLLOWED IN ORDER TO MAINTAIN YOUR PRODUCT WARRANTY!



CRITICAL INFORMATION PERTAINING TO USER AND/OR VEHICLE SAFETY IS DENOTED USING A CAUTION SIGN. SAFETY ITEMS MUST BE STRICTLY ADHERED TO IN ORDER TO ENSURE A SAFE WORKING ENVIRONMENT!



WARNING

THE USE OF DRILLS WITH INTEGRAL DRILL STOPS ALONG WITH PROPER INSPECTION FOR GAS TANK, GAS LINES, BRAKE LINES AND ELECTRICAL LINES PRIOR TO DRILLING ANY MOUNTING HOLES IS STRONGLY RECOMMENDED TO ENSURE THAT VEHICLE DAMAGE IS AVOIDED!



THE USE OF AIR OR ELECTRIC IMPACT TOOLS FOR THE ASSEMBLY OF FASTENERS COULD CAUSE FASTENER FAILURE!



THE USE OF NON-STANDARD FASTENERS AND/OR DEVIATING FROM THE FASTENERS SPECIFIED IN THESE INSTRUCTIONS MAY VOID YOUR PRODUCT WARRANTY!









ALL DRILLED HOLES IN THE VEHICLES SHOULD HAVE THE RAW METAL EDGES SEALED WITH A SELF-ETCHING PRIMER TO RESIST CORROSION AND POTENTIAL FASTENER POINT FAILURE!



DuraRac Installation Instructions – TOOL LIST



Safety glasses **MUST** be worn at all times!

TOOLS		
<p>Drill</p> 	<p>Drill Bits</p>  <p>1/2"</p>	<p>Drill Stop</p>  <p>1/2"</p>
<p>Drill</p>  <p>7/16", 13mm Socket; T45 TORX Bit with Misc. Extensions</p>	<p>Box End Wrench</p>  <p>7/16", 9/16"</p>	<p>Ratchet Wrench</p> 
<p>RECOMMENDED TOOLS:</p> <ul style="list-style-type: none"> • Inch-pound Torque Wrench • Pneumatic Plus Nut Gun • Impact Gun • Leveling Gauge 		









ALL VEHICLE CAD MODELS SHOW A LOW ROOF MODEL VEHICLE. WHILE THE ROOF HEIGHT DOES CHANGE, THE MOUNTING POINTS DO NOT CHANGE FROM LOW ROOF TO HIGH ROOF.

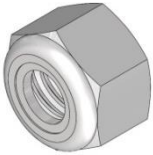

DuraRac Installation Instructions

Hardware:

						
FAS 37018 NYLOCK NUT, 1/4"-20 (QTY: 8)	FAS 19903 SERRATED FLANGE BOLT, 1/4"-20 X 3/4" (QTY: 8)	FAS 33078 FLAT WASHER, 1/4" X 5/8" O.D. (QTY: 8)	FAS 48603 3/8"-16 STRUT NUT, TALL SPRING (QTY: 4)	FAS 37341 SERRATED FLANGE NUT, 3/8" (QTY: 4)	FAS 33221 FENDER WASHER, 3/8" (QTY: 4)	FAS 10140022 TORX HEAD SCREW 3/8"-16 X 0.75"L (QTY: 8)

Step 1: Assemble Side Frame Subassemblies **Notes:**

If pre-assembled from manufacturer proceed to Step 2.

A. Assemble strut channels, angle, and baseplates into subassemblies. 1/4"-20 hardware is used at the top, and 3/8"-16 hardware is used at the bottom.

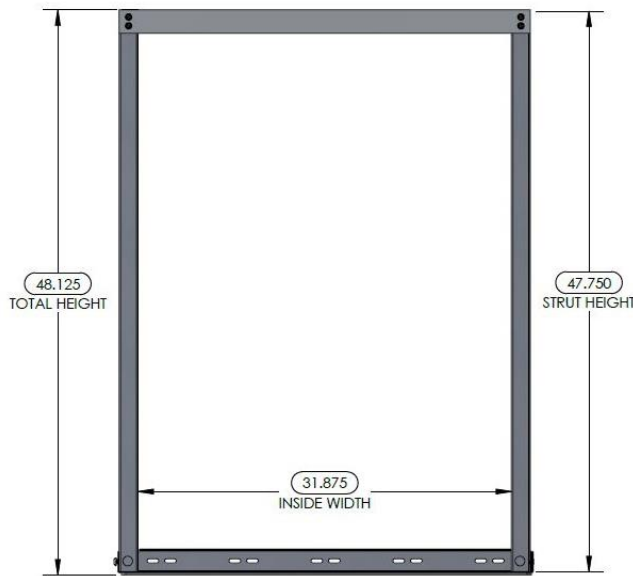





Continually check that the frame is square during assembly.

Baseplates have Curbside and Streetside callouts.

DuraRac Installation Instructions

Hardware:

 <p>FAS 0158990 M8-1.25 HEX BOLT, 40mm L (QTY: 6)</p>	 <p>FAS 33620 WASHER LOCK, 5/16" (QTY: 6)</p>	 <p>FAS 33006 5/16" FLAT WASHER(QTY: 6)</p>	 <p>FAS 12319-02380 M8-1.25 PLUS NUT (QTY: 1)</p>
---	---	--	---

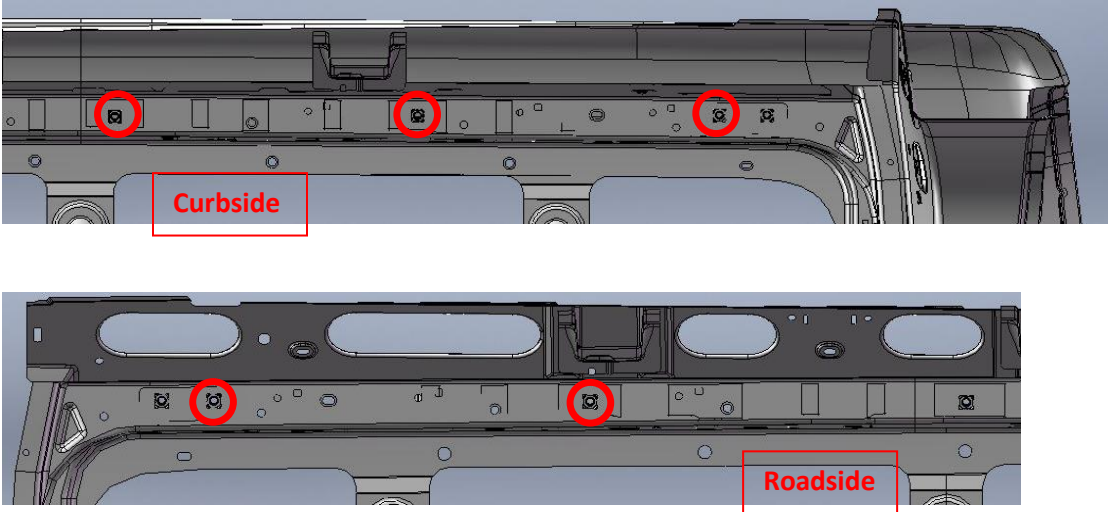
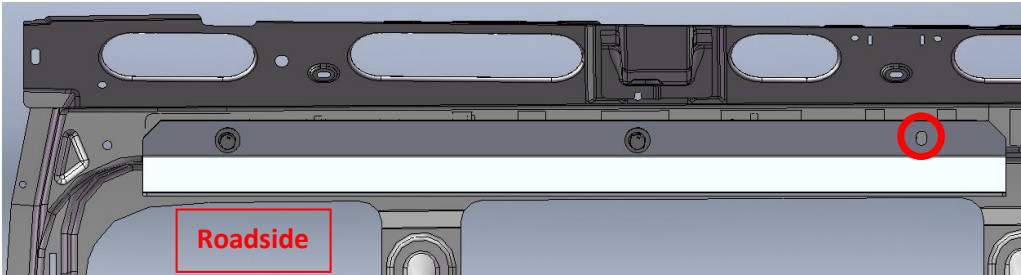





Step 2: Install Upper Mounting Brackets		Notes:
A.	<p>Insert (5) FAS 0158990 into the specified OEM holes below to mount upper mounting brackets, fasten loosely.</p> 	<p>Upper mounting brackets have callouts for Streetside and Curbside.</p> <p>Include flat and lock washers when fastening FAS 0158990.</p>
B.	<p>On the Roadside, once the first (2) bolts are in, make it so that the upper mounting bracket is parallel to the floor. Once done, drill through the last hole in the upper mounting bracket using a 1/2" drill bit. Insert a plus nut in there and loosely fasten with FAS 0158990.</p> 	<p>Use drill stop when drilling into vehicle.</p> <p>Use rust blocker or any other form of rust protection spray on drilled out holes.</p> <p>Refer to the next page on how to install plus nuts.</p>

DuraRac Installation Instructions

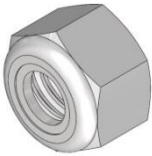
Step 2: Install Upper Mounting Brackets, <i>CONT'd.</i>		Notes:
<p data-bbox="191 426 277 495"></p> <p data-bbox="386 422 1235 485">Before drilling check all mounting locations to prevent penetration of: <i>Gas Lines, Gas Tanks, Break Lines, Wiring or any other vehicle structure.</i></p> <p data-bbox="1333 426 1419 495"></p> <p data-bbox="164 506 1463 541">There are 2 methods for installing the Plus Nuts: Manual & Automatic (They are both listed below)</p>		
C.	<p data-bbox="180 577 444 611">First Method: Manual</p> <div data-bbox="280 646 1159 863"> </div> <ol data-bbox="228 919 1227 1094" style="list-style-type: none"> 1. The Plus Nut is Pre-bulbed for easy installation. 2. The Plus Nut is pre-assembled with hex cap and hex bolt, then inserted into pre-drilled hole. 3. As the bolt is tightened the Plus Nut expands holding in place. 4. Full tightened Plus Nut provides reliable nut plate for fastening. <p data-bbox="180 1163 930 1197">Second Method: Automatic (Requires Pneumatic Plus Nut Gun)</p> <div data-bbox="420 1211 984 1665"> </div> <ol data-bbox="228 1682 922 1782" style="list-style-type: none"> 1. Thread Plus Nut onto Plus Nut Gun. 2. Screw Plus Nut into Hole. 3. When Plus Nut is fully tightened remove Plus Nut Gun. 	

DuraRac Installation Instructions

Hardware:

 <p>FAS 37018 NYLOCK NUT, 1/4"-20 (QTY: 8)</p>	 <p>FAS 19903 SERRATED FLANGE BOLT, 1/4"-20 X 3/4" (QTY: 8)</p>	 <p>FAS 33078 FLAT WASHER, 1/4" X 5/8" O.D. (QTY: 8)</p>	 <p>FAS 33620 WASHER LOCK, 5/16" (QTY: 6)</p>	 <p>FAS 33006 5/16" FLAT WASHER(QTY: 6)</p>	 <p>FAS 0158990 M8-1.25 HEX BOLT, 40mm L (QTY: 6)</p>
--	---	--	---	---	---

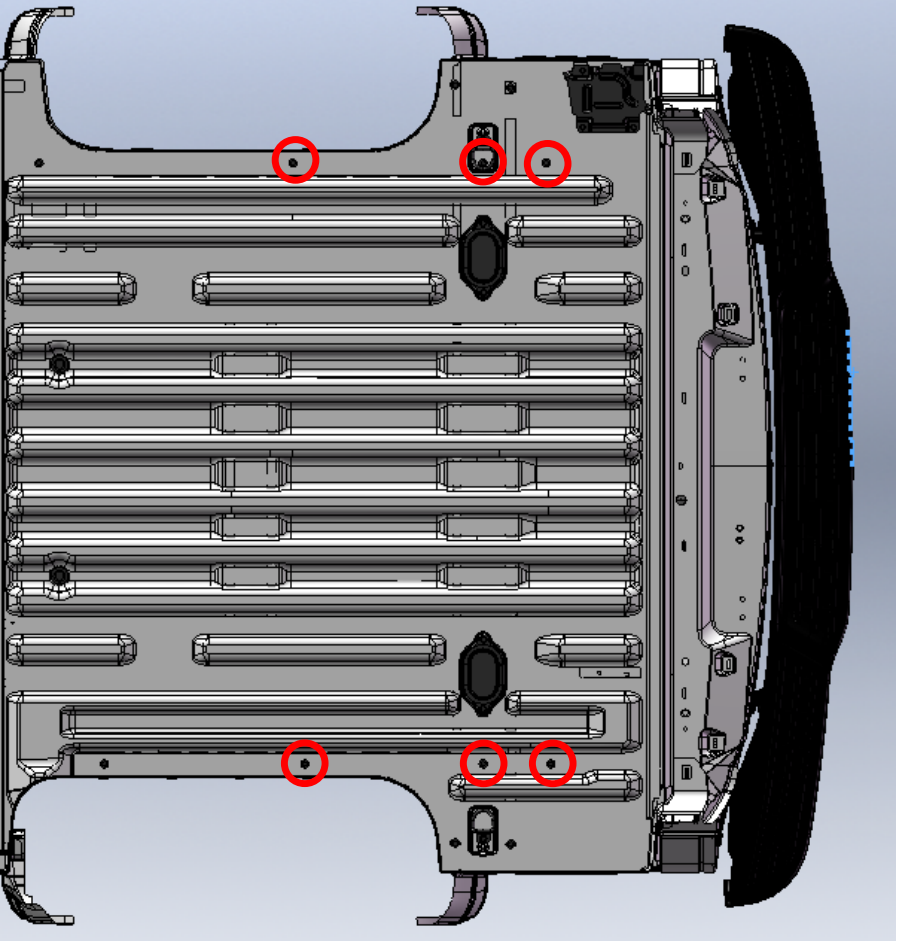
Step 3: Mount the Frame Kit in the Vehicle		Notes:
A.	<p>Remove the (6) OEM M8-1.25 bolts from the floor of the vehicle.</p>  <p>The diagram shows a top-down view of the vehicle's floor pan. Six red circles are drawn around the locations of the OEM M8-1.25 bolts that need to be removed. The bolts are located on the front and rear crossmembers, and on the side rails. The frame kit components are shown in a light gray color, and the vehicle floor is in a darker gray color.</p>	
B.	<p>Place frame kit inside the vehicle. Make sure that you have shims underneath frame kit; whether it be just placing them under loose or temporarily taping shims to baseplates.</p>	

DuraRac Installation Instructions

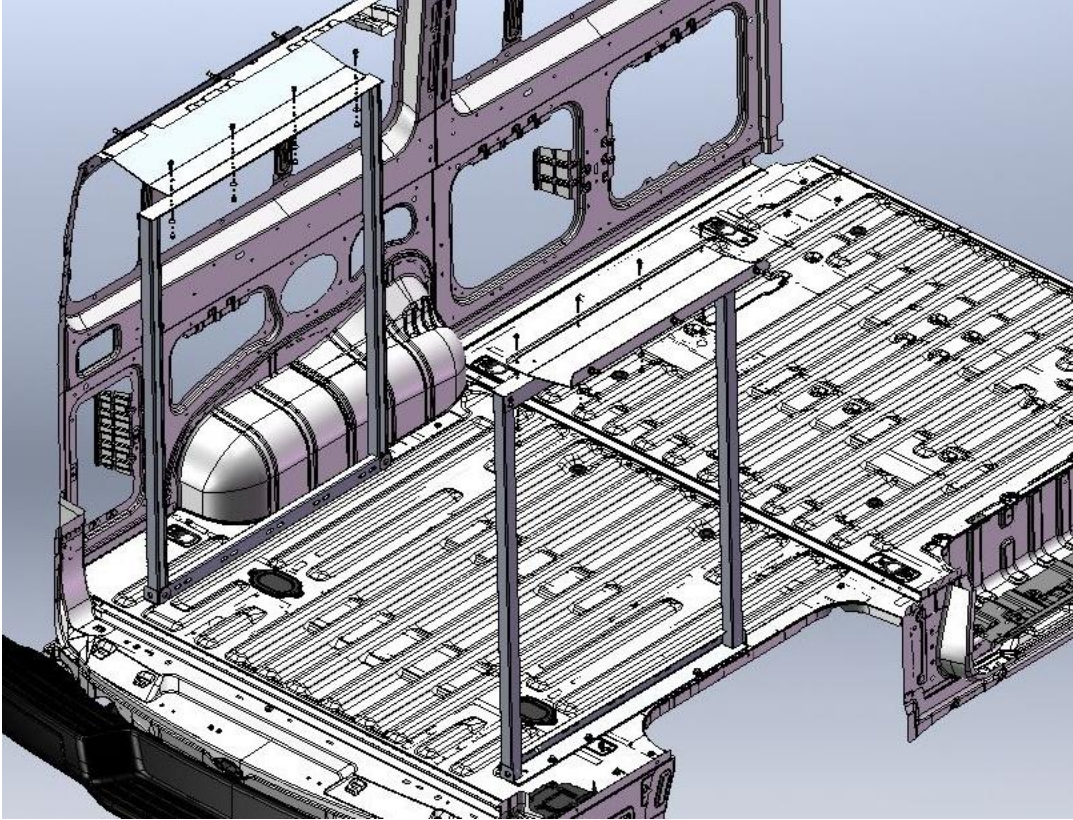
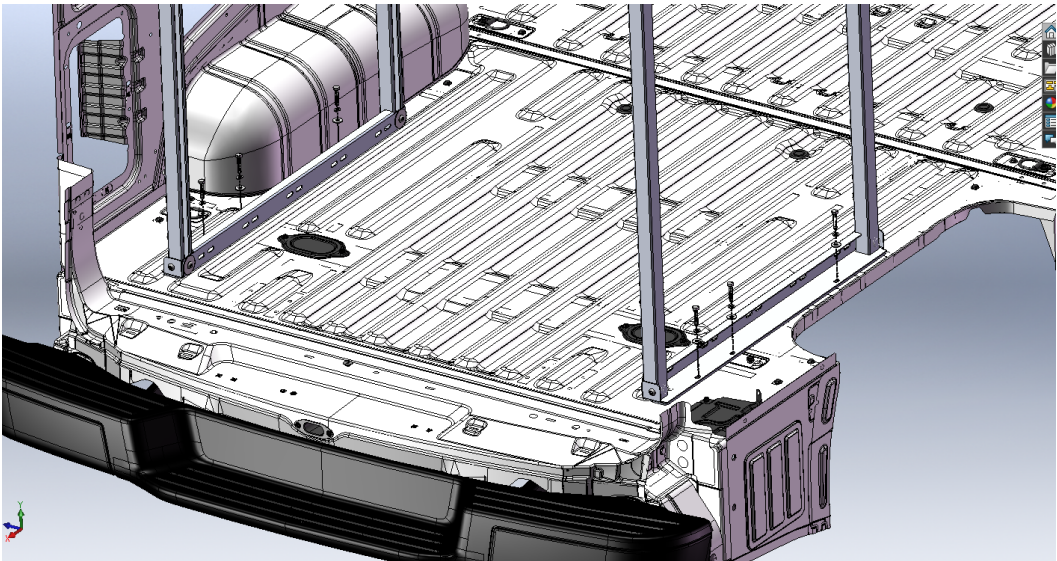
Step 3: Mount the Frame Kit in the Vehicle, <i>CONT'd.</i>		Notes:
C.	<p>Loosely fasten frame kit to upper mounting brackets using 1/4"-20 serrated bolts.</p> 	
D.	<p>Now that the frame kit is attached to the upper mounting brackets, the baseplates should be sitting above the OEM holes in the floor you removed the bolts from. Fasten baseplates loosely using (6) FAS 0158990.</p> 	<p>Include flat and lock washers when fastening FAS 0158990.</p>

DuraRac Installation Instructions

Step 3: Mount the Frame Kit in the Vehicle, *CONT'd.*

Notes:



IMPORTANT!

BEFORE MOUNTING BASEPLATES, SQUARE UP THE FRAME KIT AND MAINTAIN 48.625" IN BETWEEN THE STRUTS IN BOTH THE CURBSIDE AND ROADSIDE, AS WELL AS AT THE TOP AND BOTTOM OF THE STRUTS



E. Use a leveling gauge to confirm that the frame kit is square and confirm the following dimensions below.

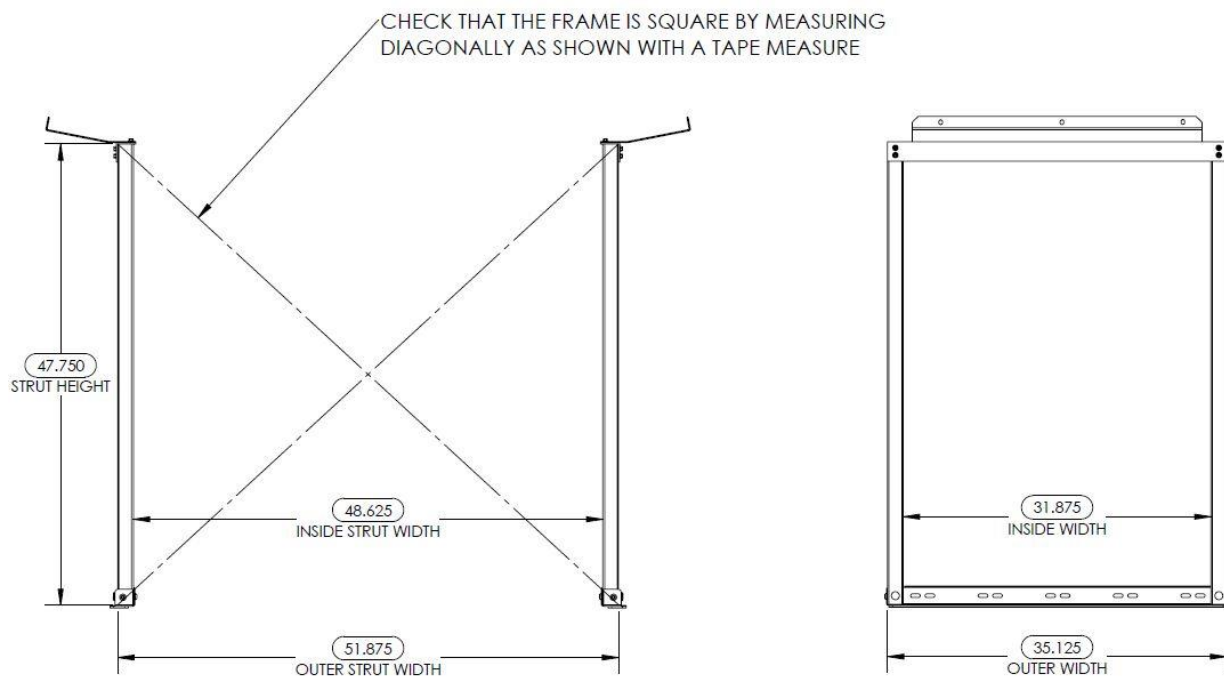

F. Once dimensions are confirmed, fasten all of the upper mounting bracket bolts and floor mounting bolts.

DuraRac Installation Instructions

Hardware:

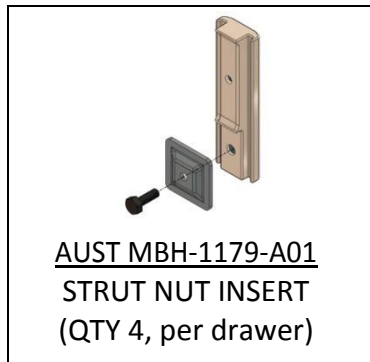

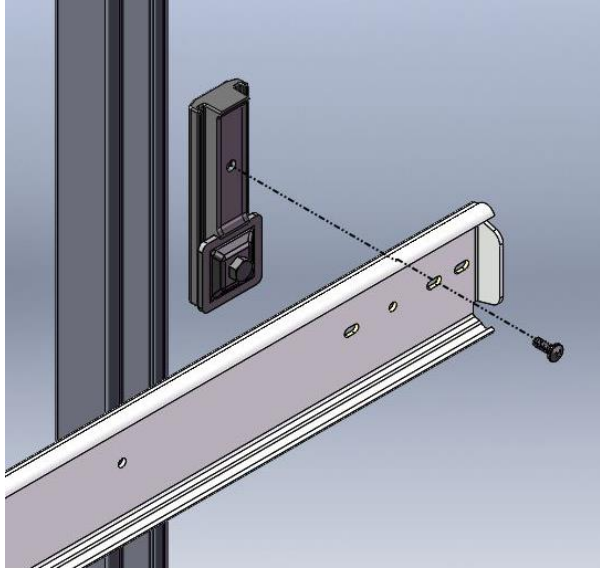
Step 4: Drawer Installation		Notes:
A.	Insert the Strut Nut assemblies into the strut channel at the exact same height and snug down $\frac{1}{4}$ "-20 hex bolts with wrench.	Align all 4 Strut Nut inserts vertically.
B.	Extend drawer fully to the locked out position. Using the (4) Pan Head Screws supplied with strut nut, securely attach slide to inserts. 	One bolt at each strut nut kit at each vertical strut
C.	Place Drawer back to the closed position (at your desired shelf height) and tighten the $\frac{1}{4}$ "-20 hex bolts to 80 in-lbs.	To adjust the shelving height, loosen $\frac{1}{4}$ "-20 hex bolts. Moving drawer parallel to floor with a second person to keep level.
D.	Repeat steps A, B, and C for each additional drawer you wish to add.	

DuraRac Installation Instructions – Bill of Material

ITEM NO.	PART NUMBER	DESCRIPTION	QTY.
1	CRF 05-1100-003	BASEPLATE SHIM, RS	1
2	CRF 05-1400-002	BASEPLATE SHIM, CS	1
3	CRF 05-1400-001	BASEPLATE, CS	1
4	CRF 05-1100-001	BASEPLATE, RS	1
5	AUST TB9002	STRUT CHANNEL, 47.75"L	4
6	CRF 05-1400-004	UPPER FRAME ANGLE	2
7	CRF 05-1100-002	UPPER MOUNTING BRACKET CS	1
8	CRF 05-1400-003	UPPER MOUNTING BRACKET RS	1
9	CRC 21-2100-001	REAR DURARAC DRAWER	TBD
10	FAS 19903	SERRATED FLANGE BOLT, 1/4"-20 X 3/4"	16
11	FAS 33078	FLAT WASHER, 1/4" X 5/8" O.D.	16
12	FAS 37018	NYLOCK NUT, 1/4"-20	16
13	FAS 33221	FENDER WASHER, 3/8" I.D. X 1.75" O.D.	4
14	FAS 10140022	BOLT, TORX, 3/8"-16 X 3/4"	8
15	FAS 48603	3/8"-16 STRUT NUT, TALL SPRING	4
16	FAS 33006	WASHER, FLAT, 5/16"	12
17	FAS 33620	WASHER, LOCK, 5/16"	12
18	FAS 0158990	M8-1.25 X 40MM HEX BOLT	12
19	FAS 37341	3/8"-16 SERRATED FLANGE NUT	4
20	FAS 12319-02380	M8-1.25 PLUS NUT	1
21	AUST MBH-1179-A01	STRUT NUT INSERT (4 PER DRAWER)	TBD

DuraRac Installation Instructions – Technical Drawing

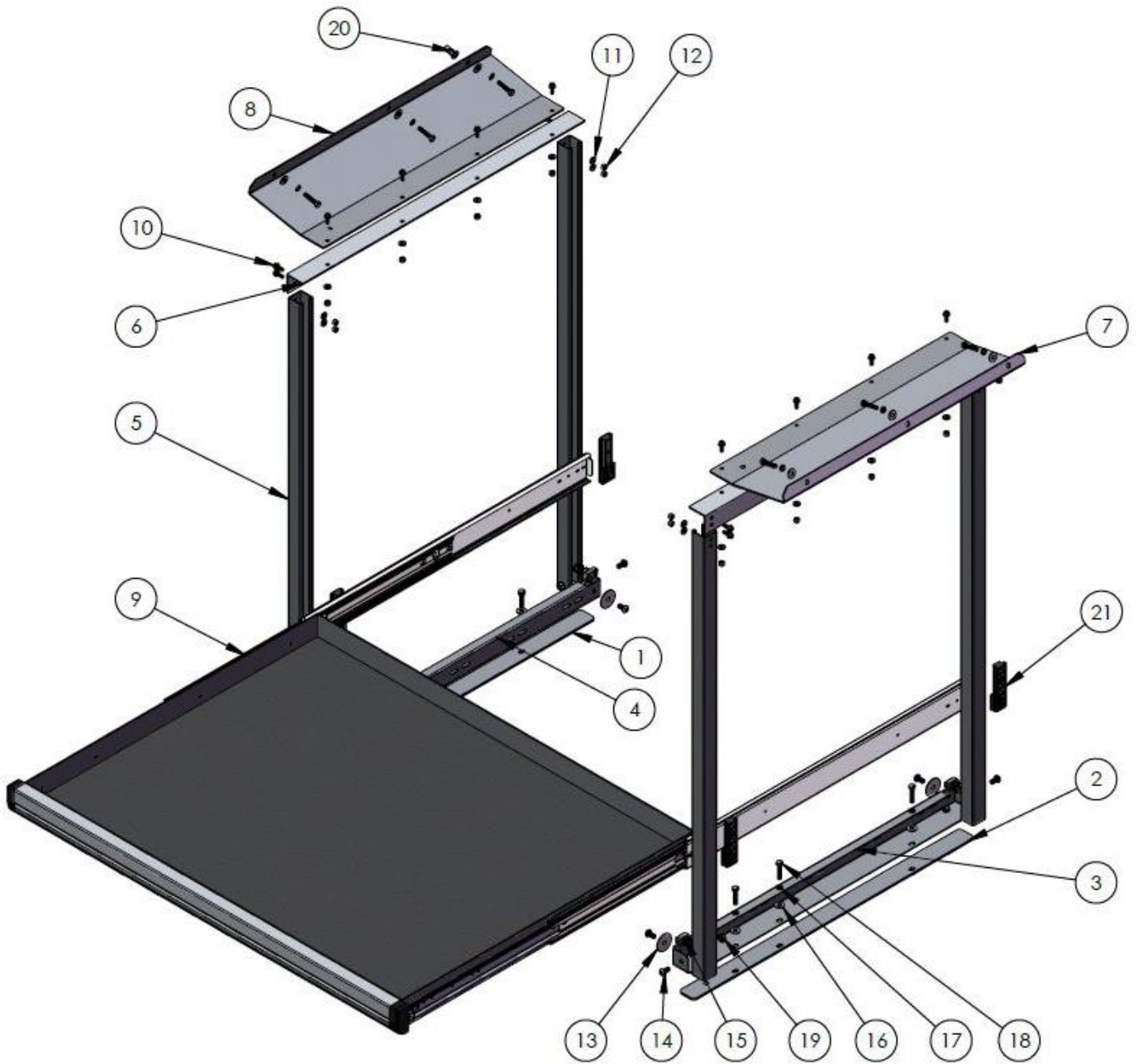

DuraRac Installation Instructions – Inspection Dimensions

