

DTP HD DA 4K Series

DTP HDMI Distribution Amplifiers



Safety Instructions

Safety Instructions • English

WARNING: This symbol, ⚠, when used on the product, is intended to alert the user of the presence of uninsulated dangerous voltage within the product's enclosure that may present a risk of electric shock.

ATTENTION: This symbol, ⚠, when used on the product, is intended to alert the user of important operating and maintenance (servicing) instructions in the literature provided with the equipment.

For information on safety guidelines, regulatory compliances, EMI/EMF compatibility, accessibility, and related topics, see the Extron Safety and Regulatory Compliance Guide, part number 68-290-01, on the Extron website, www.extron.com.

Sicherheitsanweisungen • Deutsch

WARNUNG: Dieses Symbol ⚠ auf dem Produkt soll den Benutzer darauf aufmerksam machen, dass im Inneren des Gehäuses dieses Produktes gefährliche Spannungen herrschen, die nicht isoliert sind und die einen elektrischen Schlag verursachen können.

VORSICHT: Dieses Symbol ⚠ auf dem Produkt soll dem Benutzer in der im Lieferumfang enthaltenen Dokumentation besonders wichtige Hinweise zur Bedienung und Wartung (Instandhaltung) geben.

Weitere Informationen über die Sicherheitsrichtlinien, Produkthandhabung, EMI/EMF-Kompatibilität, Zugänglichkeit und verwandte Themen finden Sie in den Extron-Richtlinien für Sicherheit und Handhabung (Artikelnummer 68-290-01) auf der Extron-Website, www.extron.com.

Instrucciones de seguridad • Español

ADVERTENCIA: Este símbolo, ⚠, cuando se utiliza en el producto, avisa al usuario de la presencia de voltaje peligroso sin aislar dentro del producto, lo que puede representar un riesgo de descarga eléctrica.

ATENCIÓN: Este símbolo, ⚠, cuando se utiliza en el producto, avisa al usuario de la presencia de importantes instrucciones de uso y mantenimiento recogidas en la documentación proporcionada con el equipo.

Para obtener información sobre directrices de seguridad, cumplimiento de normativas, compatibilidad electromagnética, accesibilidad y temas relacionados, consulte la Guía de cumplimiento de normativas y seguridad de Extron, referencia 68-290-01, en el sitio Web de Extron, www.extron.com.

Instructions de sécurité • Français

AVERTISSEMENT : Ce pictogramme, ⚠, lorsqu'il est utilisé sur le produit, signale à l'utilisateur la présence à l'intérieur du boîtier du produit d'une tension électrique dangereuse susceptible de provoquer un choc électrique.

ATTENTION : Ce pictogramme, ⚠, lorsqu'il est utilisé sur le produit, signale à l'utilisateur des instructions d'utilisation ou de maintenance importantes qui se trouvent dans la documentation fournie avec le matériel.

Pour en savoir plus sur les règles de sécurité, la conformité à la réglementation, la compatibilité EMI/EMF, l'accessibilité, et autres sujets connexes, lisez les informations de sécurité et de conformité Extron, réf. 68-290-01, sur le site Extron, www.extron.com.

Istruzioni di sicurezza • Italiano

AVVISO: Questo simbolo, ⚠, quando viene utilizzato il prodotto, serve ad avvisare l'utente della presenza di tensioni pericolose non isolate all'interno del prodotto, che può presentare un rischio di scosse elettriche.

ATTENZIONE: Questo simbolo, ⚠, quando viene utilizzato il prodotto, serve ad avvisare l'utente di importanti istruzioni di uso e manutenzione (assistenza) nella letteratura fornita con l'apparecchiatura.

Per informazioni sulle linee guida di sicurezza, adempimenti normativi, compatibilità EMI/EMF, accessibilità e argomenti correlati, vedere la sicurezza di Extron e Regulatory Compliance Guide, parte numero 68-290-01, sul sito Web Extron, www.extron.com.

Instrukcje bezpieczeństwa • Polska

OSTRZEŻENIE: Ten symbol, ⚠, gdy używany na produkt, ma na celu poinformować użytkownika o obecności izolowanego i niebezpiecznego napięcia wewnątrz obudowy produktu, który może stanowić zagrożenie porażenia prądem elektrycznym.

UWAGI: Ten symbol, ⚠, gdy używany na produkt, jest przeznaczony do ostrzegania użytkownika ważne operacyjne oraz instrukcje konserwacji (obsługi) w literaturze, wyposażone w sprzęt.

Informacji na temat wytycznych w sprawie bezpieczeństwa, regulacji wzajemnej zgodności, zgodność EMI/EMF, dostępności i Tematy pokrewne, zobacz Extron bezpieczeństwa i regulacyjnego zgodności przewodnik, część numer 68-290-01, na stronie internetowej Extron, www.extron.com.

Инструкция по технике безопасности • Русский

ПРЕДУПРЕЖДЕНИЕ: Данный символ, ⚠, если указан на продукте, предупреждает пользователя о наличии неизолированного опасного напряжения внутри корпуса продукта, которое может привести к поражению электрическим током.

ВНИМАНИЕ: Данный символ, ⚠, если указан на продукте, предупреждает пользователя о наличии важных инструкций по эксплуатации и обслуживанию в руководстве, прилагаемом к данному оборудованию.

Для получения информации о правилах техники безопасности, соблюдении нормативных требований, электромагнитной совместимости (ЭМП/ЭДС), возможности доступа и других вопросах см. руководство по безопасности и соблюдению нормативных требований Extron на сайте Extron: , www.extron.com, номер по каталогу - 68-290-01.

安全说明 • 简体中文

警告: ⚠产品上的这个标志意在警告用户该产品机壳内有暴露的危险电压, 有触电危险。

注意: ⚠产品上的这个标志意在提示用户设备随附的用户手册中有重要的操作和维护(维修)说明。

关于我们产品的安全指南、遵循的规范、EMI/EMF的兼容性、无障碍使用的特性等相关内容, 敬请访问 Extron 网站, www.extron.com, 参见 Extron 安全规范指南, 产品编号 68-290-01。

安全記事・繁體中文

警告: ⚠ 若產品上使用此符號，是為了提醒使用者，產品機殼內存在著可能會導致觸電之風險的未絕緣危險電壓。

注意: ⚠ 若產品上使用此符號，是為了提醒使用者，設備隨附的用戶手冊中有重要的操作和維護（維修）說明。

有關安全性指導方針、法規遵守、EMI/EMF 相容性、存取範圍和相關主題的詳細資訊，請瀏覽 Extron 網站：www.extron.com，然後參閱《Extron 安全性與法規遵守手冊》，準則編號 68-290-01。

安全上のご注意・日本語

警告: この記号 ⚠ が製品上に表示されている場合は、筐体内に絶縁されていない高電圧が流れ、感電の危険があることを示しています。

注意: この記号 ⚠ が製品上に表示されている場合は、本機の取扱説明書に記載されている重要な操作と保守(整備)の指示についてユーザーの注意を喚起するものです。

安全上のご注意、法規遵守、EMI/EMF適合性、その他の関連項目については、エクストロンのウェブサイト www.extron.com より『Extron Safety and Regulatory Compliance Guide』(P/N 68-290-01) をご覧ください。

안전 지침・한국어

경고: 이 기호 ⚠ 가 제품에 사용될 경우, 제품의 인클로저 내에 있는 접지되지 않은 위험한 전류로 인해 사용자가 감전될 위험이 있음을 경고합니다.

주의: 이 기호 ⚠ 가 제품에 사용될 경우, 장비와 함께 제공된 책자에 나와 있는 주요 운영 및 유지보수(정비) 지침을 경고합니다.

안전 가이드라인, 규제 준수, EMI/EMF 호환성, 접근성, 그리고 관련 항목에 대한 자세한 내용은 Extron 웹 사이트(www.extron.com)의 Extron 안전 및 규제 준수 안내서, 68-290-01 조항을 참조하십시오.

FCC Class A Notice

This equipment has been tested and found to comply with the limits for a Class A digital device, pursuant to part 15 of the FCC rules. The Class A limits provide reasonable protection against harmful interference when the equipment is operated in a commercial environment. This equipment generates, uses, and can radiate radio frequency energy and, if not installed and used in accordance with the instruction manual, may cause harmful interference to radio communications. Operation of this equipment in a residential area is likely to cause interference. This interference must be corrected at the expense of the user.

ATTENTION: The Twisted Pair Extension technology works with unshielded twisted pair (UTP) or shielded twisted pair (STP) cables; **but to ensure FCC Class A and CE compliance, STP cables and STP Connectors are required.**

For more information on safety guidelines, regulatory compliances, EMI/EMF compatibility, accessibility, and related topics, see the “[Extron Safety and Regulatory Compliance Guide](#)” on the Extron website.

Battery Notice

This product contains a battery. **Do not open the unit to replace the battery.** If the battery needs replacing, return the entire unit to Extron (for the correct address, see the [Extron Warranty](#) section on the last page of this guide).

CAUTION: Risk of explosion. Do not replace the battery with an incorrect type. Dispose of used batteries according to the instructions.

ATTENTION : Risque d’explosion. Ne pas remplacer la pile par le mauvais type de pile. Débarrassez-vous des piles usagées selon le mode d’emploi.

Copyright

© 2018 Extron Electronics. All rights reserved.

Trademarks

All trademarks mentioned in this guide are the properties of their respective owners.

All trademarks mentioned in this guide are the properties of their respective owners.

The following registered trademarks^(®), registered service marks^(SM), and trademarks^(TM) are the property of RGB Systems, Inc. or Extron Electronics (see the current list of trademarks on the [Terms of Use](#) page at www.extron.com):

Registered Trademarks ^(®)
Extron, AVTrac, Cable Cubby, ControlScript, CrossPoint, DTP, eBUS, EDID Manager, EDID Minder, Flat Field, FlexOS, Global Configurator, Global Scriptor, GlobalViewer, Hideaway, Inline, IP Intercom, IP Link, Key Minder, LinkLicense, LockIt, MediaLink, MediaPort, NetPA, PlenumVault, PoleVault, PowerCage, PURE3, Quantum, SoundField, SpeedMount, SpeedSwitch, System <i>INTEGRATOR</i> , TeamWork, TouchLink, V-Lock, VersaTools, VN-Matrix, VoiceLift, WallVault, WindoWall, XTP, and XTP Systems
Registered Service Mark^(SM) : S3 Service Support Solutions
Trademarks ^(TM)
AAP, AFL (Accu-Rate Frame Lock), ADSP (Advanced Digital Sync Processing), Auto-Image, CableCover, CDRS (Class D Ripple Suppression), DDSP (Digital Display Sync Processing), DMI (Dynamic Motion Interpolation), Driver Configurator, DSP Configurator, DSVP (Digital Sync Validation Processing), eLink, EQIP, EverLast, FastBite, FOX, FOXBOX, HyperLane, IP Intercom HelpDesk, MAAp, MicroDigital, Opti-Torque, ProDSP, QS-FPC (QuickSwitch Front Panel Controller), Room Agent, Scope-Trigger, ShareLink, SIS, Simple Instruction Set, Skew-Free, SpeedNav, Triple-Action Switching, True4K, Vector TM 4K , WebShare, XTRA, ZipCaddy, and ZipClip

Conventions Used in this Guide

Notifications

The following notifications are used in this guide:

CAUTION: Risk of minor personal injury.

ATTENTION : Risque de blessure mineure.

ATTENTION:

- Risk of property damage.
- Risque de dommages matériels.

NOTE: A note draws attention to important information.

TIP: A tip provides a suggestion to make working with the application easier.

Software Commands

Commands are written in the fonts shown here:

```
^ARMerge Scene, ,Op1 scene 1,1 ^B 51 ^W^C  
[ 01 ] R000400300004000080000600 [ 02 ] 35 [ 17 ] [ 03 ]
```

```
Esc|X1*|X17*|X20*|X23*|X21|CE ←
```

NOTE: For commands and examples of computer or device responses mentioned in this guide, the character “0” is used for the number zero and “O” is the capital letter “o.”

Computer responses and directory paths that do not have variables are written in the font shown here:

```
Reply from 208.132.180.48: bytes=32 times=2ms TTL=32  
C:\Program Files\Extron
```

Variables are written in slanted form as shown here:

```
ping xxx.xxx.xxx.xxx -t  
SOH R Data STX Command ETB ETX
```

Selectable items, such as menu names, menu options, buttons, tabs, and field names are written in the font shown here:

```
From the File menu, select New.  
Click the OK button.
```

Specifications Availability

Product specifications are available on the Extron website, www.extron.com.

Extron Glossary of Terms

A glossary of terms is available at www.extron.com/technology/glossary.aspx.



Contents

Introduction.....	1
DTP HD DA 4K Series Description.....	1
Features	1
Application Diagrams.....	3

Installation and Operation.....	4
Mounting the Units	4
Tabletop Use	4
Mounting Kits	4
UL Rack-Mounting Guidelines	4
Front Panel Features.....	5
Rear Panel Features	6
Connecting the Input Source	8
Twisted Pair Recommendations for DTP Communication	9
Supported Cables	9
Cable Recommendations	9
Wiring for RS-232 Control	10

SIS Commands	11
Introduction to SIS	11
Host-to-Distribution Amplifier Communications	11
Distribution Amplifier-initiated Messages	11
Copyright Information	11
Symbols Used in this Guide.....	12
Symbol Definitions	12
Error Messages	14
EDID.....	14
DTP HD DA 4K Series EDID Memory Locations.....	15
Command and Response Table for SIS Commands	16

Reference Information	21
Using the Internal Web Pages.....	21
Accessing the Internal Web Pages.....	21
Setting Up the Device with the Internal Web Pages.....	22
Updating the Device Firmware	23
Downloading Firmware	23
Downloading and Installing PCS	23
Loading Firmware to the DA with PCS.....	24
Loading Firmware to the DA with Internal Web Pages.....	26

Introduction

This guide describes the function, installation, and operation of the DTP HD DA4 4K and DTP HD DA8 4K series of distribution amplifiers. Unless otherwise stated, the terms “distribution amplifier” or “DA” refer to any of the products in the series.

This section provides the following information:

- [DTP HD DA 4K Series Description](#)
- [Features](#)
- [Application Diagrams](#)

DTP HD DA 4K Series Description

These Extron distribution amplifiers distribute one HDMI input signal to four (DTP HD DA4 4K 230 and DTP HD DA4 4K 330 models) or eight (DTP HD DA8 4K 230 and DTP HD DA8 4K 330 models) simultaneous outputs over shielded twisted pair (STP) cables. The 230 models distribute one HDMI input signal up to 230 feet (70 meters) and the 330 models distribute one HDMI input signal up to 330 feet (100 meters). All models are fully High-bandwidth Digital Content Protection (HDCP) compliant.

These distribution amplifiers support data rates up to 10.2 Gbps (3.4 Gbps per color) with up to 12-bit deep color and use the EDID Minder feature for EDID management.

The automatic output compatibility correction feature scans each output device to ensure that the output signal is compatible with the color depth and format requirements of the device. Each output is adjusted independently.

Features

- **Distributes HDMI plus control and analog audio up to 230 feet (70 meters) or 330 feet (100 meters) over STP cable (depending on the model)**
- **Inputs: One HDMI with buffered input loop-through, one 3.5 mm stereo mini jack for audio with loop-through**
- **Outputs: Four (DTP HD DA4 4K models) or eight (DTP HD DA8 4K models) DTP twisted pair outputs on RJ-45**
- **Supports computer video up to 2560x1600, HDTV 1080p/60 Deep Color, and 4K resolutions**
- **DTP outputs are compatible with HDBaseT-enabled devices** — Each DTP output can be configured to send video and embedded audio, plus bidirectional RS-232 and IR signals to an HDBaseT-enabled device.
- **HDMI input loop-through** — The DTP HD DA 4K series features an active local HDMI output for local monitor support or system expansion.
- **Audio input with loop-through accepts additional analog stereo audio signals** — The DTP HD DA 4K series accepts stereo analog audio signals for simultaneous transmission over the same shielded twisted pair cable, and it includes a loop-through for local audio system and monitoring needs. Analog audio is not embedded onto the digital video signal, nor is digital audio de-embedded from the digital video signal.

- **Supports multiple embedded audio formats** — The DTP HD DA 4K series is compatible with a broad range of multi-channel audio signals, providing reliable operation with HDMI sources.
- **Remote powering of DTP receivers** — The DTP HD DA 4K series can provide power to four or eight DTP receivers over the twisted pair connections, eliminating the need for separate power supplies at the remote units.
- **RS-232 insertion from the Ethernet control port** — System level AV device control to all remote locations via the Ethernet port on the distribution amplifier, providing control of the attached devices without needing additional equipment.
- **Bidirectional RS-232 and IR pass-through for AV device control** — Bidirectional RS-232 control and IR signals can be transmitted alongside the video signal, allowing remote AV devices to be controlled without the need for additional cabling.
- **HDCP compliant**
- **Supported HDMI specification features include data rates up to 10.2 Gbps, Deep Color up to 12-bit, 3D, and HD lossless audio formats**
- **Key Minder continuously verifies HDCP compliance** — Key Minder authenticates and maintains continuous HDCP encryption between input and output devices to enable simultaneous distribution of a single source signal to two or more displays.
- **EDID Minder automatically manages EDID communication between connected devices** — EDID Minder ensures that the source powers up properly and reliably outputs content for display.
- **Supports EDID and HDCP transmission** — DDC channels are actively buffered, allowing continuous communication between source and display.
- **HDCP authentication and signal presence confirmation** — Provides real-time verification of HDCP status for each digital video input and output.
- **HDCP Visual Confirmation provides a green signal when encrypted content is sent to a non-compliant display** — A full-screen green signal is sent when HDCP-encrypted content is transmitted to a non-HDCP compliant display, providing immediate visual confirmation that protected content cannot be viewed on the display.
- **HDMI to DVI Interface Format Correction** — Automatically enables or disables embedded audio and InfoFrames, and sets the correct color space for proper connection to HDMI and DVI displays.
- **RS-232 control port** — Enables the use of serial commands for integration into a control system. Extron products use the SIS - Simple Instruction Set command protocol, a set of basic ASCII commands that allow for quick and easy programming.
- **RJ-45 signal and link LED indicators for DTP ports** — Provides a means for validating signal flow and operation.
- **Compatible with all DTP 230 and DTP 330 Series receivers and DTP-enabled products** — Enables mixing and matching with desktop and wallplate receivers, as well as other DTP-enabled products to meet application requirements.

Application Diagrams

The diagrams below show typical applications for the DTP HD DA 4K series.

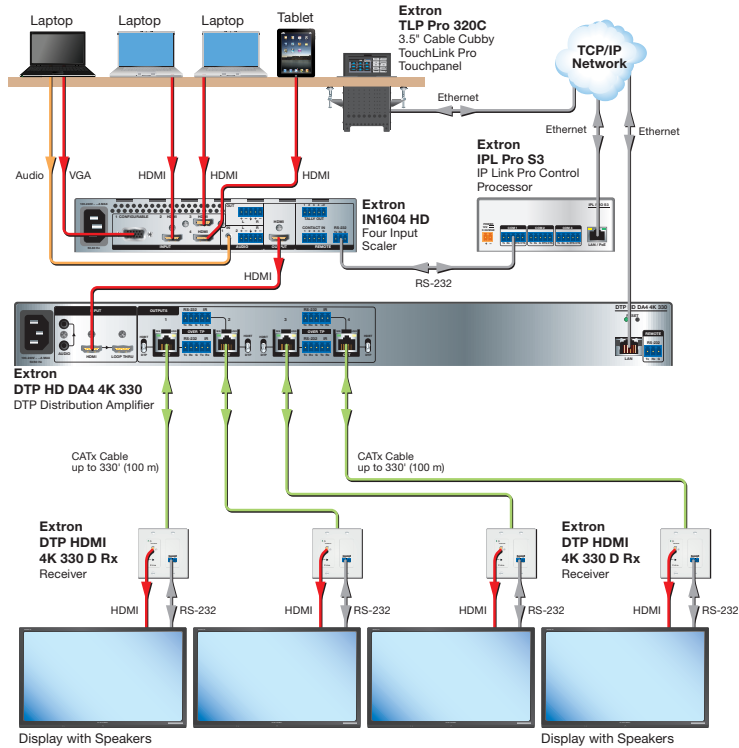

Figure 1. DTP HD DA4 4K Application Diagram

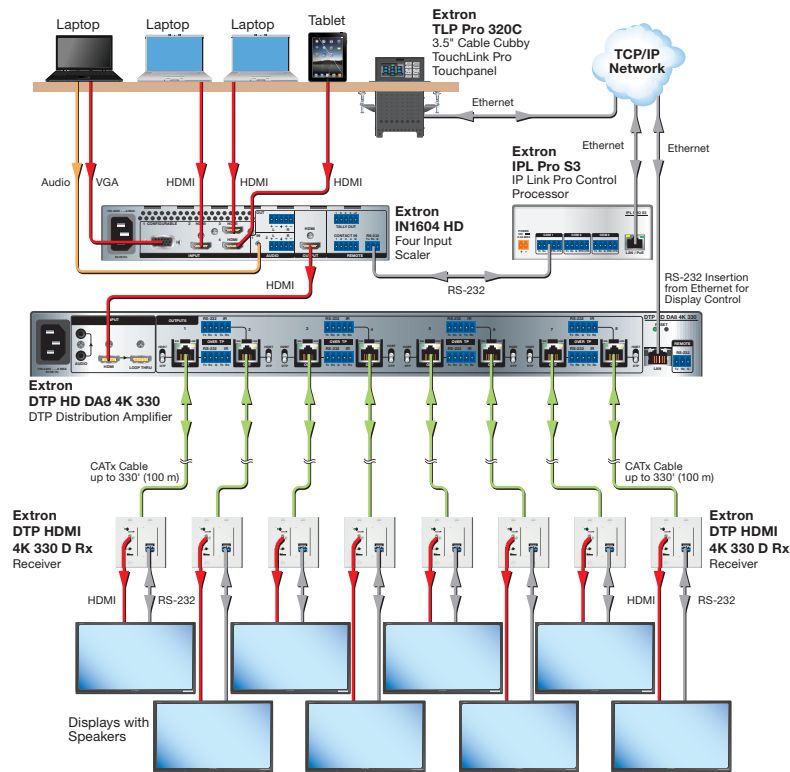

Figure 2. DTP HD DA8 4K Application Diagram

Installation and Operation

This section of the guide describes the following topics concerned with the installation, setup, and operation of the DTP HD DA 4K series of distribution amplifiers.

- **Mounting the Units**
- **Front Panel Features**
- **Rear Panel Features**
- **Connecting the Input Source**
- **Twisted Pair Recommendations for DTP Communication**
- **Wiring for RS-232 Control**

Mounting the Units

ATTENTION:

- Installation and service must be performed by authorized personnel only.
- L'installation et l'entretien doivent être effectués par le personnel autorisé uniquement.

The DTP HD DA 4K series of distribution amplifiers can be placed on a table, mounted in a rack, or mounted under a desk or table.

Tabletop Use

Attach the included rubber feet to the bottom of the unit and place it in any convenient location.

Mounting Kits

Mount the unit using any optional compatible mounting kit listed on the Extron website (www.extron.com), in accordance with the directions included with the kit. For rack mounting, see "UL Rack-Mounting Guidelines" below.

UL Rack-Mounting Guidelines

The following Underwriters Laboratories (UL) requirements pertain to the installation of the unit into a rack.

- **Elevated operating ambient temperature** — If installed in a closed or multi-unit rack assembly, the operating ambient temperature of the rack environment may be greater than room ambient. Therefore, consider installing the equipment in an environment compatible with the maximum ambient temperature (TMA = +122 °F, +50 °C) specified by Extron.

- **Reduced air flow** — Installation of the equipment in a rack should be such that the amount of air flow required for safe operation of the equipment is not compromised.
- **Mechanical loading** — Mounting of the equipment in the rack should be such that a hazardous condition is not achieved due to uneven mechanical loading.
- **Circuit overloading** — Consideration should be given to the connection of the equipment to the supply circuit and the effect that overloading of the circuits might have on overcurrent protection and supply wiring. Appropriate consideration of equipment nameplate ratings should be used when addressing this concern.
- **Reliable Earthing** — Reliable earthing of rack-mounted equipment should be maintained. Particular attention should be given to supply a connection other than a direct connection to a branch circuit, such as by using a power strip.

Front Panel Features

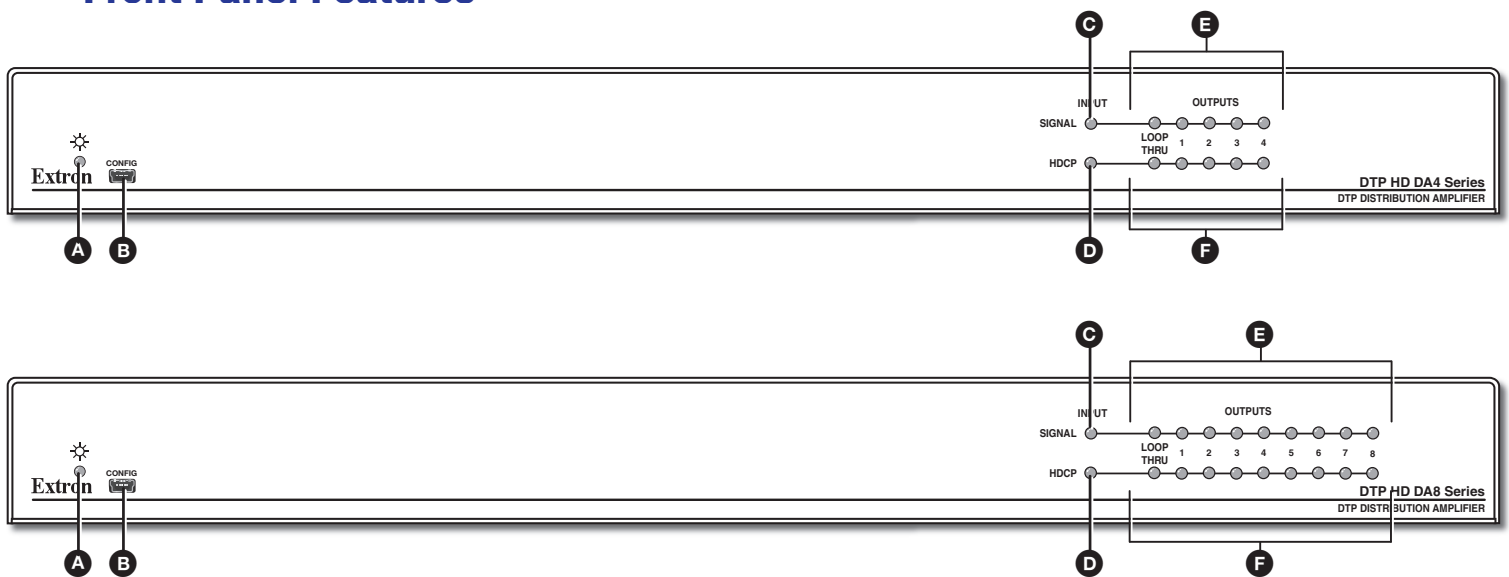

Figure 3. DTP HD DA 4K Series Front Panel

- A Power status LED** — Lights green when power is applied to the unit.
- B USB Config port** — Used for firmware updates, SIS configuration, and software control. This port can be used as an alternative to the rear panel Remote RS-232 captive screw connector (See Rear Panel Features on the following page).

NOTES:

- Neither port has precedence and commands from either port are handled in the order they are received.
- Extron recommends that the USB port is used for temporary connections. If a permanent connection is required, the RS-232 port or an IP connection should be used.

- C Input Signal LED** — Lights green when a signal is detected on the HDMI input.
- D Input HDCP LED** — Lights green when HDCP presence is detected on the HDMI input.
- E Output Signal LEDs** — Light green when a signal is detected on the HDMI outputs.
- F Output HDCP LEDs** — Light green when HDCP presence is detected on the HDMI outputs.

Rear Panel Features

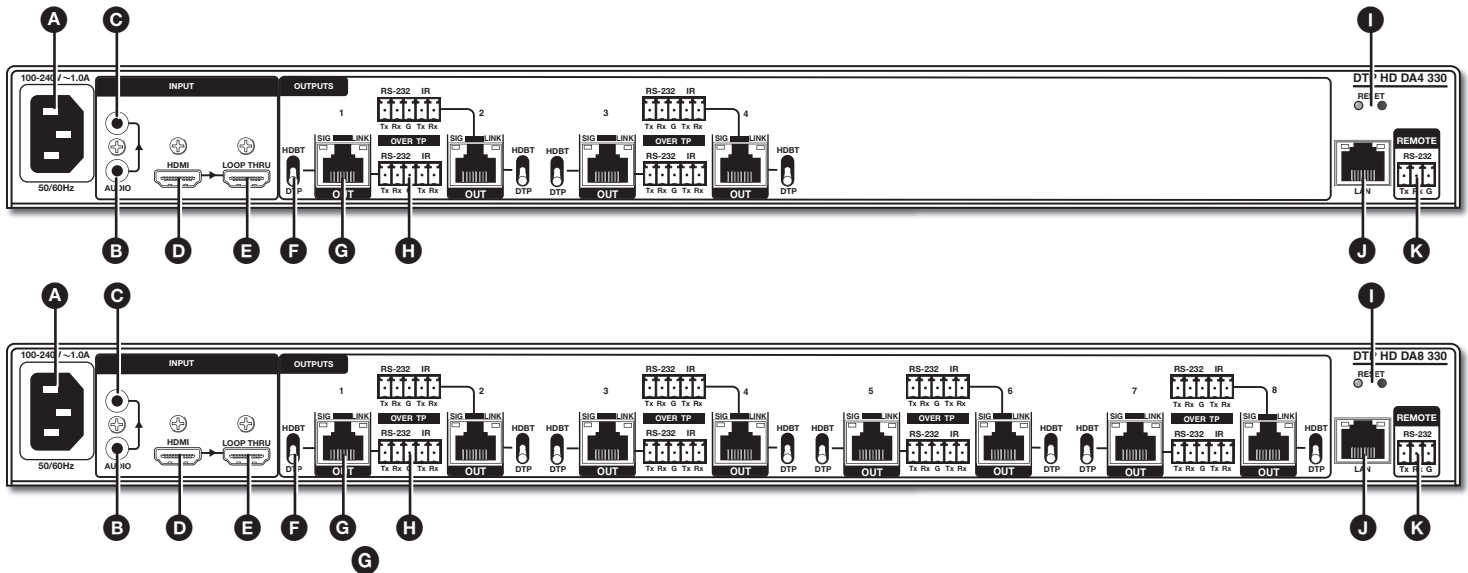

- A Power input**
- B Analog audio input**
- C Analog audio Loop Thru**
- D HDMI input**
- E HDMI Loop Thru**
- F DTP/HDBaseT configuration switches**
- G DTP/HDBaseT outputs**
- H Over TP RS-232/IR connectors**
- I Reset button and LED**
- J LAN connector**
- K Remote RS-232 connector**

Figure 4. DTP HD DA 4K Series Rear Panel

- A Power input** — Connect the provided IEC connector to a 100-240 VAC (50 or 60 Hz) power source.
- B Analog audio input** — Connect an unbalanced stereo audio source to these 3.5 mm mini stereo jacks.

NOTE: The units do NOT embed analog audio onto the HDMI signal. This analog audio signal is transmitted simultaneously with audio embedded within the HDMI signal.

- C Analog audio Loop Thru** — Connect an audio system to this 3.5 mm mini stereo jack for local loop-through monitoring of the source audio.
- D HDMI input** — Connect a source device to this female HDMI type A connector (see [Connecting the Input Source](#) on page 8 for more information).
- E HDMI Loop Thru** — Connect a display to this female HDMI type A connector for local loop-through monitoring of the source signal (see [Connecting the Input Source](#) on page 8 for more information).
- F DTP/HDBaseT configuration switch** — Set this 2-position, recessed switch to configure the output between DTP and HDBaseT modes. When configured for DTP, use a DTP-compatible receiver. When configured for HDBaseT, use an HDBaseT-compatible receiver.
- G DTP/HDBaseT outputs** — Use STP cables to connect these 4 (DA4 models) or 8 (DA8 models) outputs (see Figure 4 on the previous page) to the inputs of a compatible receiver (see [Twisted Pair Recommendations for DTP Communication](#) on page 9

for more information).

ATTENTION:

- Do not connect these outputs to a telecommunications or computer data network.
- Ne connectez pas ces appareils à des données informatiques ou à un réseau de télécommunications.

H RS-232 Over TP port — To pass bidirectional serial control between DTP-compatible or HDBaseT-compatible devices, connect a control device to the 5-pole captive screw connector. This port includes only the 3 poles labeled “RS-232” (see image below for wiring instructions).

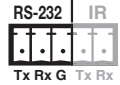

IR Over TP port — To transmit and receive IR signals, connect a control device to the 5-pole captive screw connector. This port includes only the 2 poles labeled “IR” and shares the ground pole with the RS-232 port (see figure 5 for wiring instructions).

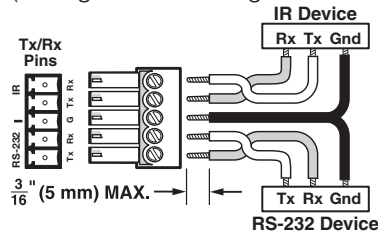
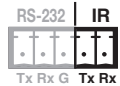

Figure 5. RS-232 and IR Wiring for the Over TP Port

NOTE: RS-232 and IR data can be transmitted simultaneously.

I Reset button and LED — To reset the unit to factory default settings, press and hold this **reset** button for approximately 9 seconds. The reset LED flashes green 3 times, once every 3 seconds. After the third flash, release the button and quickly press it once more to complete the reset. The LED flashes green 3 times indicating that the default settings have been restored.

J LAN (Ethernet) connector — Use an RJ-45 cable to connect this jack to a LAN (Ethernet) for control of the device.

- Use a straight-through cable for connection to a switch, hub, or router.
- Use a crossover cable or a straight-through cable for connection directly to a PC. Wire the connector as shown in figure 6.

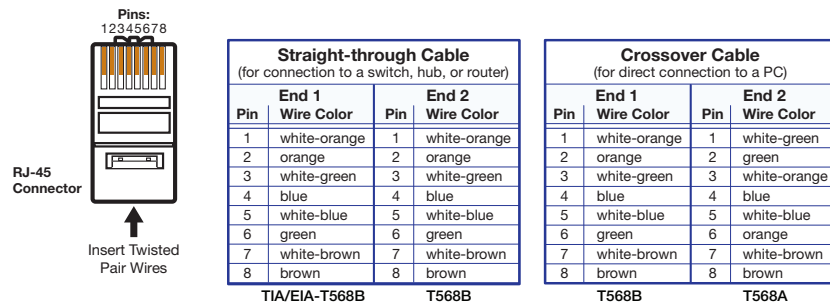

Figure 6. LAN Connector Wiring

K Remote RS-232 connector — (see Figure 4 on page 6) To control the unit, connect an RS-232 device to this 3-pole, 3.5 mm captive screw connector and configure it as follows: 9600 baud rate, 8 data bits, 1 stop bit, no parity (see **Wiring for RS-232**

Control on page 10 for more information).

Connecting the Input Source

Use an HDMI cable to connect the input source to the female HDMI socket on the rear panel (6).

Follow these instructions to secure the input and output HDMI connectors to the unit with the LockIt HDMI lacing bracket provided:

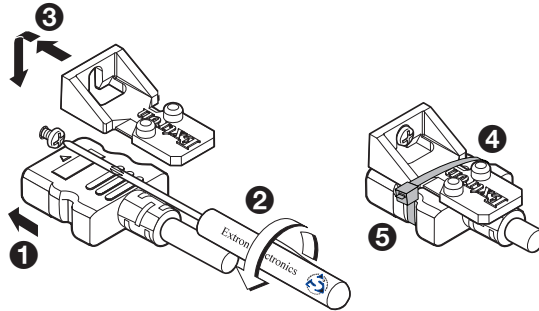

Figure 7. LockIt Installation

1. Plug the HDMI cable into the rear panel connection (1).
2. Loosen the HDMI connection mounting screw from the panel enough to allow the LockIt lacing bracket to be placed over it (2). The screw does not have to be removed.
3. Place the LockIt lacing bracket on the screw and against the HDMI connector, then tighten the screw to secure the bracket (3).

ATTENTION:

- Do not overtighten the HDMI connection mounting screw. The shield it fastens to is very thin and can easily be stripped.
- Ne serrez pas trop la vis de montage de la connexion HDMI. Le blindage auquel elle est attachée est très fin et peut facilement être dénudé.

4. Loosely place the included tie wrap around the HDMI connector and the LockIt lacing bracket as shown (4).
5. While holding the connector securely against the lacing bracket, tighten the tie wrap, then remove any excess length (5).

Twisted Pair Recommendations for DTP Communication

Use the following pin configurations for shielded twisted pair cables.

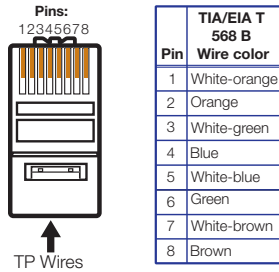

Figure 8. Twisted Pair Wiring Diagram

Supported Cables

The distribution amplifiers are compatible with shielded twisted pair cable (F/UTP, SF/UTP, and S/FTP).

ATTENTION:

- Do not use Extron UTP23SF-4 Enhanced Skew-Free AV UTP cable or STP201 cable to link the device with DTP transmitters or receivers.
- N'utilisez pas le câble AV Skew-Free UTP version améliorée UTP23SF d'Extron ou le câble STP201 pour relier le appareil avec les émetteurs ou les récepteurs DTP.

Cable Recommendations

Extron recommends using the following practices to achieve full transmission distances and reduce transmission errors.

- Use the following Extron XTP DTP 24 SF/UTP cables and connectors for the best performance:
 - **XTP DTP 24/1000** Non-Plenum 1000' (305 m) spool 22-236-03
 - **XTP DTP 24P/1000** Plenum 1000' (305 m) spool 22-235-03
 - **XTP DTP 24 Plug** Package of 10 101-005-02
- If not using XTP DTP 24 cable, at a minimum, Extron recommends 24 AWG, solid conductor, STP cable with a minimum bandwidth of 400 MHz.
- Terminate cables with shielded connectors to the TIA/EIA-T568B standard.
- Limit the use of more than two pass-through points, which may include patch points, punch down connectors, couplers, and power injectors. If these pass-through points are required, use shielded couplers and punch down connectors.

NOTE: When using shielded twisted pair cable in bundles or conduits, consider the following:

- Do not exceed 40% fill capacity in conduits.
- Do not comb the cable for the first 20 meters, where cables are straightened, aligned, and secured in tight bundles.
- Loosely place cables and limit the use of tie wraps or hook-and-loop fasteners.
- Separate twisted pair cables from AC power cables.

Wiring for RS-232 Control

RS-232 communication between the distribution amplifier and a host PC can be used to update firmware or configure the unit using SIS commands (see **Command and Response Table for SIS Commands** on page 16).

The computer connects to either the rear panel 3-pole RS-232 port (K on page 8) or the front panel USB port (see Figure 4 B on page 6) of the distribution amplifier.

NOTES:

- Neither port has precedence and commands from either port are handled in the order they are received.
- Extron recommends that the USB port is used for temporary connections. If a permanent connection is required, the RS-232 port should be used.

1. Connect an RS-232 cable to the computer, using a female 9-pin D connector (see figure 4):
 - Data received by the computer = pin 2
 - Data transmitted by the computer = pin 3
 - Ground = pin 5
2. Wire the opposite end of the cable to the provided 3-pole captive screw plug (see figure 9):
 - Data transmitted by the DA plugs into the Tx (transmit) port
 - Data received by the DA plugs into the Rx (receive) port
 - Ground plugs into the G (ground) port

NOTES:

- The wiring in the RS-232 cables crosses over so that the Tx on the distribution amplifier connects to the Rx of the control device and vice versa. Ground always connects to ground.
- If the cable has a drain wire, tie the drain wire to the ground at both ends.

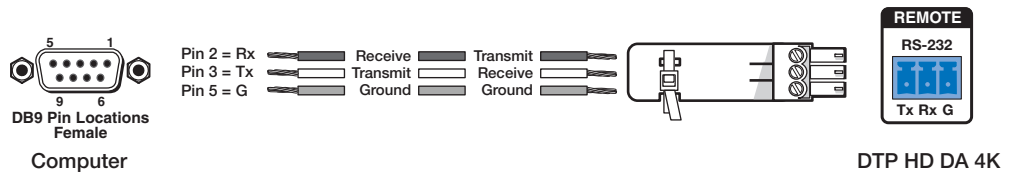

Figure 9. Wiring the DTP HD DA 4K Series for RS-232 Control

SIS Commands

This section provides information about the SIS commands that are used to configure the DTP HD DA 4K series. The following topics are discussed:

- [Introduction to SIS](#)
- [Symbols Used in this Guide](#)
- [DTP HD DA4 Series EDID Memory Locations](#)
- [Command and Response Table for SIS Commands](#)

Introduction to SIS

The distribution amplifiers can be set up and controlled remotely via Extron SIS commands that are issued from a host computer running the Extron DataViewer utility or other control system. The host device can be connected to the RJ-45 LAN connector on the rear panel, the 3-pole captive screw connector on the rear panel, or to the mini USB config port on the front panel.

The serial protocol is 9600 baud, 8 data bit, 1 stop bit, and no parity.

NOTE: The wiring in the RS-232 cables crosses over so that the distribution amplifier transmit (Tx) wire connects with the control device receive (Rx) and vice versa.

Host-to-Distribution Amplifier Communications

SIS commands consist of strings (one or more characters per command field). No special characters are required to begin or end a command sequence. Unless otherwise stated, upper and lower case characters can be used interchangeably. Most responses from the distribution amplifier end with a carriage return and a line feed (CR/LF = `↵`), which signal the end of the response character string. When the switcher determines that a command is valid, it executes the command and sends a response to the host device.

Distribution Amplifier-Initiated Messages

When a local event such as a change in signal status takes place, the distribution amplifier responds by sending a message to the host, indicating the status change. No response is required from the host.

Copyright Information

The copyright message is displayed upon connecting to a DA via TCP/IP or Telnet or after a power cycle via RS-232. An example is provided below.

```
↵ (©) Copyright 20yy, Extron Electronics, DTP HD DA8 4K 330, Vx.xx,  
60-xxxx-01↵
```

```
Mon, 6 Feb 2017 11:27:33 ↵
```

20yy is the year the currently installed firmware was released, Vx.xx is the firmware version number, and 60-xxxx-01 is the catalog part number.

This is followed by a **Password** prompt if a password has been set.

Symbols Used in this Guide

When programming in the field, certain characters are most conveniently represented by their hexadecimal rather than their ASCII values. The table below shows the hexadecimal equivalent of each ASCII character:

ASCII to HEX Conversion Table										Esc	1B	CR	0D	LF	0A
Space	20	!	21	"	22	#	23	\$	24	%	25	&	26	'	27
(28)	29	*	2A	+	2B	,	2C	-	2D	.	2E	/	2F
0	30	1	31	2	32	3	33	4	34	5	35	6	36	7	37
8	38	9	39	:	3A	:	3B	<	3C	=	3D	>	3E	?	3F
@	40	A	41	B	42	C	43	D	44	E	45	F	46	G	47
H	48	I	49	J	4A	K	4B	L	4C	M	4D	N	4E	O	4F
P	50	Q	51	R	52	S	53	T	54	U	55	V	56	W	57
X	58	Y	59	Z	5A	[5B	\	5C]	5D	^	5E	_	5F
`	60	a	61	b	62	c	63	d	64	e	65	f	66	g	67
h	68	i	69	j	6A	k	6B	l	6C	m	6D	n	6E	o	6F
p	70	q	71	r	72	s	73	t	74	u	75	v	76	w	77
x	78	y	79	z	7A	{	7B		7C	}	7D	~	7E	DEL	7F

Figure 10. ASCII to HEX Conversion Table

Symbol Definitions

- = Space
- ↵ = Carriage return with line feed
- | or ← = Carriage return with no line feed
- Esc** = Escape
or W
- X1** = Output selection
 - Ø - 4 or loop out to 4 (DTP HD DA4 models)
 - Ø - 8 or loop out to 8 (DTP HD DA8 models)
- X2** = Status
 - Ø = disabled/off/undetected
 - 1 = enabled/on/detected
- X3** = Video color bit depth
 - Ø = auto (based on EDID of sink, **default**)
 - 1 = force 8-bit
- X4** = EDID memory location
 - See the **DTP HD DA4/DA8 EDID Memory Locations** table on page 15.
- X5** = EDID data as 256 bytes of hex data (text representation)
- X6** = Native resolution and refresh rate (translated from hex)
 - Example: 1600x1200 @60Hz*
- X7** = Controller firmware version to the second decimal place
- X8** = Unit name: Up to 24 alphanumeric characters (including the hyphen [-])
 - No spaces allowed
 - No distinction between upper and lower case letters
 - First character must be a letter
 - Last character cannot be a hyphen (-)
 - Default is model name followed by last 3 pairs of digits of MAC address
- X9** = Output 5V mode
 - Ø = Auto (5V enabled when 5V source present, else off)
 - 1 = 5V always enabled (**default**)
- X10** = RS-232 insertion mode
 - Ø = RS-232 pass through (**default**)
 - 1 = Embedded RS-232

X11	=	TMD5 output format	<p>∅ = Auto (default), pass through if HDMI sink, force DVI format if DVI sink</p> <p>1 = DVI</p> <p>2 = HDMI RGB "Full"</p> <p>3 = HDMI RGB "Limited"</p> <p>4 = HDMI YUV 444 "Limited"</p> <p>5 = HDMI YUV 444 "Full"</p> <p>6 = HDMI YUV 422 "Limited"</p> <p>7 = HDMI YUV 422 "Full"</p>
X12	=	HDCP output mode	<p>∅ = Encrypt as required by input (Continuous trials for HDMI sinks, attempt for 10 seconds on DVI sinks, then fail)</p> <p>1 = Always encrypt (Continuous trials for HDMI sinks, attempt for 10 seconds on DVI sinks, then fail)</p> <p>2 = Encrypt as required by input (Continuous trials for HDMI sinks and DVI sinks)</p> <p>3 = Always encrypt (Continuous trials for HDMI sinks and DVI sinks)</p>
X13	=	DTP/HDBaseT switch position	<p>∅ = DTP mode</p> <p>1 = HDBaseT mode</p>
X14	=	Verbose mode	<p>∅ = Clear/none (default for telnet)</p> <p>1 = Verbose mode (default for RS-232 and USB)</p> <p>2 = Tagged responses for queries</p> <p>3 = Verbose mode and tagged responses for queries</p>
X15	=	Set date/time	<p>MM/DD/YY-HH:MM:SS</p> <p>Example: 06/21/02-10:54:00</p>
X16	=	IP address	<p>xxx.xxx.xxx.xxx</p> <p>(192.168.254.254 = default)</p>
X17	=	MAC address	∅∅-∅5-A6-xx-xx-xx
X18	=	Subnet mask	xxx.xxx.xxx.xxx (255.255.∅.∅ = default)
X19	=	Password	12 digits and alphanumeric characters for user or admin passwords.
X57	=	Port number	<p>∅1 = Remote RS-232/RS-422 port</p> <p>∅2 = unused</p> <p>∅3-1∅ = UARTs 1 through 8</p>
X58	=	Baud rate	<p>Default = 9600</p> <p>Port 1 is fixed at 9600</p>
X59	=	Parity	Odd, Even, None (default), Mark, Space (only the first letter is required)
X60	=	Data bits	<p>7-8</p> <p>(8 = default)</p>
X61	=	Stop bits	<p>1, 2</p> <p>(1 = default)</p>
X64	=	Port timeout intervals	<p>1-65∅∅∅</p> <p>(1 = 10 seconds; default = 30 - 300 seconds = 5 minutes, in 10-second increments)</p>
X65	=	Start point for UART ports	1999 = default
X66	=	Video mute	<p>∅ = Video mute disabled</p> <p>1 = Video mute</p> <p>2 = Video and sync mute</p>
X67	=	View HDCP Notification	∅ = Green Screen (default); 1 = Black Screen

Error Messages

- E01 — Invalid input channel number
- E10 — Invalid command
- E13 — Invalid value
- E24 — Privilege violation
- E28 — Bad filename / File not found

EDID

User assigned mode

In user assigned mode, the user can select from 55 factory loaded EDID files, each categorized by rate type (PC or HDTV), video format (DVI or HDMI), audio type (2-Ch or Multi-Ch), and native resolution. The unit retains this setting after a power cycle.

Additionally, two user-loaded slots are available to save the EDID of any connected display. EDID saved to these slots are retained after a power cycle. Upon a factory reset, these EDID revert to the factory default (720p @ 60 Hz, 2-Ch audio).

A table showing the factory loaded EDID options is shown on the following page. The EDID memory location is labelled **x4** for consistency with the value in the SIS commands.

DTP HD DA 4K Series EDID Memory Locations

4	Native Resolution	Refresh Rate	Rate Type	Video Format	Audio Type	File Name	4	Native Resolution	Refresh Rate	Rate Type	Video Format	Audio Type	File Name
1	800x600	60 Hz	PC	DVI	n/a	EXN_DV1_800x600_60.bin	36	480p	60 Hz	HDTV	HDMI	2-ch	EXN_HDMI20_480p60_2Ch Audio.bin
2	1024x768	60 Hz	PC	DVI	n/a	EXN_DV2_1024x768_60.bin	37	576p	50 Hz	HDTV	HDMI	2-ch	EXN_HDMI21_576p60_2Ch Audio.bin
3	1280x720	60 Hz	PC	DVI	n/a	EXN_DV3_1280x720_60.bin	38	720p	50 Hz	HDTV	HDMI	2-ch	EXN_HDMI22_720p60_2Ch Audio.bin
4	1280x768	60 Hz	PC	DVI	n/a	EXN_DV4_1280x768_60.bin	39*	720p	60 Hz	HDTV	HDMI	2-ch	EXN_HDMI23_720p60_2Ch Audio.bin
5	1280x800	60 Hz	PC	DVI	n/a	EXN_DV5_1280x800_60.bin	40	1080i	50 Hz	HDTV	HDMI	2-ch	EXN_HDMI24_1080i50_2Ch Audio.bin
6	1280x1024	60 Hz	PC	DVI	n/a	EXN_DV6_1280x1024_60.bin	41	1080i	60 Hz	HDTV	HDMI	2-ch	EXN_HDMI25_1080i60_2Ch Audio.bin
7	1360x768	60 Hz	PC	DVI	n/a	EXN_DV7_1360x768_60.bin	42	1080p	50/25 Hz	HDTV	HDMI	2-ch	EXN_HDMI26_1080p50_25_2Ch Audio.bin
8	1366x768	60 Hz	PC	DVI	n/a	EXN_DV8_1366x768_60.bin	43	1080p	50 Hz	HDTV	HDMI	2-ch	EXN_HDMI27_1080p50_2Ch Audio.bin
9	1400x1050	60 Hz	PC	DVI	n/a	EXN_DV9_1400x1050_60.bin	44	1080p	60/24 Hz	HDTV	HDMI	2-ch	EXN_HDMI28_1080p60_24_2Ch Audio.bin
10	1440x900	60 Hz	PC	DVI	n/a	EXN_DV10_1440x900_60.bin	45	1080p	60 Hz	HDTV	HDMI	2-ch	EXN_HDMI29_1080p60_2Ch Audio.bin
11	1600x900	60 Hz	PC	DVI	n/a	EXN_DV11_1600x900_60.bin	46	4k / UHD	30 Hz	HDTV	HDMI	2-ch	EXN_HDMI30_4KUHD_30_2Ch Audio.bin
12	1600x1200	60 Hz	PC	DVI	n/a	EXN_DV12_1600x1200_60.bin	47	720p	50 Hz	HDTV	HDMI	multi-ch	EXN_HDMI31_720p50_MultiCh Audio.bin
13	1680x1050	60 Hz	PC	DVI	n/a	EXN_DV13_1680x1050_60.bin	48	720p	60 Hz	HDTV	HDMI	multi-ch	EXN_HDMI32_720p60_MultiCh Audio.bin
14	1920x1080	60 Hz	PC	DVI	n/a	EXN_DV14_1920x1080_60.bin	49	1080i	50 Hz	HDTV	HDMI	multi-ch	EXN_HDMI33_1080i50_MultiCh Audio.bin
15	1920x1200	60 Hz	PC	DVI	n/a	EXN_DV15_1920x1200_60.bin	50	1080i	60 Hz	HDTV	HDMI	multi-ch	EXN_HDMI34_1080i60_MultiCh Audio.bin
16	2048x1080	60 Hz	PC	DVI	n/a	EXN_DV16_2048x1080_60.bin	51	1080p	50/25 Hz	HDTV	HDMI	multi-ch	EXN_HDMI35_1080p50_25_MultiCh Audio.bin
17	800x600	60 Hz	PC	HDMI	2-ch	EXN_HDMI1_800x600_60_2Ch Audio.bin	52	1080p	50 Hz	HDTV	HDMI	multi-ch	EXN_HDMI36_1080p50_MultiCh Audio.bin
18	1024x768	60 Hz	PC	HDMI	2-ch	EXN_HDMI2_1024x768_60_2Ch Audio.bin	53	1080p	60/24 Hz	HDTV	HDMI	multi-ch	EXN_HDMI37_1080p60_24_MultiCh Audio.bin
19	1280x768	60 Hz	PC	HDMI	2-ch	EXN_HDMI3_1280x768_60_2Ch Audio.bin	54	1080p	60 Hz	HDTV	HDMI	multi-ch	EXN_HDMI38_1080p60_MultiCh Audio.bin
20	1280x800	60 Hz	PC	HDMI	2-ch	EXN_HDMI4_1280x800_60_2Ch Audio.bin	55	4k / UHD	30 Hz	HDTV	HDMI	multi-ch	EXN_HDMI39_4KUHD_30_MultiCh Audio.bin
21	1280x1024	60 Hz	PC	HDMI	2-ch	EXN_HDMI5_1280x1024_60_2Ch Audio.bin	56	Loop-Through					
22	1360x768	60 Hz	PC	HDMI	2-ch	EXN_HDMI6_1360x768_60_2Ch Audio.bin	57	Output 1					
23	1366x768	60 Hz	PC	HDMI	2-ch	EXN_HDMI7_1366x768_60_2Ch Audio.bin	58	Output 2					
24	1400x1050	60 Hz	PC	HDMI	2-ch	EXN_HDMI8_1400x1050_60_2Ch Audio.bin	59	Output 3					
25	1440x900	60 Hz	PC	HDMI	2-ch	EXN_HDMI9_1440x900_60_2Ch Audio.bin	60	Output 4					
26	1600x900	60 Hz	PC	HDMI	2-ch	EXN_HDMI10_1600x900_60_2Ch Audio.bin	61	Output 5 (DA8)					
27	1600x1200	60 Hz	PC	HDMI	2-ch	EXN_HDMI11_1600x1200_60_2Ch Audio.bin	62	Output 6 (DA8)					
28	1680x1050	60 Hz	PC	HDMI	2-ch	EXN_HDMI12_1680x1050_60_2Ch Audio.bin	63	Output 7 (DA8)					
29	1920x1200	60 Hz	PC	HDMI	2-ch	EXN_HDMI13_1920x1200_60_2Ch Audio.bin	64	Output 8 (DA8)					
30	1920x2160	60 Hz	PC	HDMI	2-ch	EXN_HDMI14_1920x2160_60_2Ch Audio.bin	65	User loaded slot 1					
31	2048x1080	60 Hz	PC	HDMI	2-ch	EXN_HDMI15_2048x1080_60_2Ch Audio.bin	66	User loaded slot 2					Manually populated by user
32	2048x2160	60 Hz	PC	HDMI	2-ch	EXN_HDMI16_2048x2160_60_2Ch Audio.bin	*Default						
33	2560x1080	60 Hz	PC	HDMI	2-ch	EXN_HDMI17_2560x1080_60_2Ch Audio.bin							
34	2560x1440	60 Hz	PC	HDMI	2-ch	EXN_HDMI18_2560x1440_60_2Ch Audio.bin							
35	2560x1600	60 Hz	PC	HDMI	2-ch	EXN_HDMI19_2560x1600_60_2Ch Audio.bin							

Command and Response Table for SIS Commands

Command	ASCII Command (host to unit)	Response (unit to host)	Additional Description
Video Mute			
Video mute single output	X1 * X66 B	Vmt X1 * X66 ↵	Video mute output X1 only 1, 2, 3, or 4 (DA4) 1, 2, 3, 4, 5, 6, 7, or 8 (DA8) X66 = 0 (video mute disabled) or 1 (video mute TMDS) or 2 (video and sync mute)
Video mute all outputs	X66 B	Vmt X66 ↵	
Query video mute status	B	X66 • X66 •...• X66 ↵	Video mute status of outputs 0 to 4 (0 = loop out) for DA4, or 0 to 8 (0 = loop out) for DA8
Analog Audio Mute			
Audio mute single output	X1 * X2 Z	Amt X1 * X2 ↵	Audio mute output X1 only X2 = 0 (audio mute disabled) or 1 (audio mute)
Audio mute all outputs	X2 Z	Amt X2 ↵	
Query audio mute status	Z	X2 • X2 •...• X2 ↵	Audio mute status of outputs 0 to 4 (0 = loop out) for DA4, or 0 to 8 (0 = loop out) for DA8
HDMI (embedded) Audio Mute			
Audio mute single output	Esc X1 * X2 AFMT ←	Afmt X1 * X2 ↵	Audio mute output X1 only X2 = 0 (audio mute disabled) or 1 (audio mute)
Audio mute all outputs	Esc X2 AFMT ←	Afmt X2 ↵	
Query audio mute status	Esc AFMT ←	X2 • X2 •...• X2 ↵	Audio mute status of outputs 0 to 4 (0 = loop out) for DA4, or 0 to 8 (0 = loop out) for DA8
TMDS Output Format			
Set format for single output	Esc X1 * X11 VTPO ←	Vtpo X1 * X11 ↵	X11 = 0 - 7 (0 = default)
Set format for all outputs	Esc X11 VTPO ←	Vtpo X11 ↵	
Query format settings	Esc VTPO ←	X11 • X11 •...• X11 ↵	TMDS settings of outputs 0 to 4 (0 = loop out) for DA4, or 0 to 8 (0 = loop out) for DA8
Video Color Bit Depth			
Set video bit depth for a single output	Esc V X1 * X3 BITD ←	BitdV X1 * X3 ↵	X3 = 0 (auto, sink EDID, default) 1 (force 8-bit)
Set video bit depth for all outputs	Esc V X3 BITD ←	BitdV X3 ↵	
Query video bit depth for all outputs	Esc VBITD ←	X3 • X3 •...• X3 ↵	Video bit depth of outputs 0 to 4 (0 = loop out) for DA4, or 0 to 8 (0 = loop out) for DA8

Command	ASCII Command (host to unit)	Response (unit to host)	Additional Description
HDCP Output Mode			
Set HDCP output mode for a single output	[Esc]S [X1]*[X12] HDCP ←	HdcpS [X1]*[X12] ↵	[X1] = 1 - 4 (DA4) or 1 - 8 (DA8)
Set HDCP output mode for all outputs	[Esc]S [X12] HDCP ←	HdcpS [X12] ↵	[X12] = 0 - 3 (0 is default)
Query HDCP output mode for all outputs	[Esc]S HDCP ←	[X12]•[X12]•...[X12] ↵	Video bit depth of outputs 0 to 4 (0 = loop out) for DA4, or 0 to 8 (0 = loop out) for DA8
Signal Status (unsolicited)			
Request all signal status	[Esc]L S ←	[X2]*[X2]•[X2]•...[X2] ↵	Input * Outputs local-max
Request all HDCP status	[Esc] HDCP ←	[X2]*[X2]•[X2]•...[X2] ↵	Input * Outputs local-max
HDCP Authorized Device			
HDCP authorization enable/disable	[Esc]E [X2] HDCP ←	HdcpE [X2] ↵	[X2] = 0 (disabled) 1 (enabled, default)
Query HDCP authorization status	[Esc]E HDCP ←	[X2] ↵	
EDID Minder			
Assign EDID to input	[Esc]A [X4] EDID ←	EdidA [X4] ↵	[X4] = EDID memory location (1 - 66) see the DTP HD DA4/DA8 4K EDID Memory Locations table on page 15 (default is 39 [720p @ 60 Hz, 2-ch audio])
View EDID assignment	[Esc]A EDID ←	[X4] ↵	
Save EDID of output to user location	[Esc]S [X1]*[X4] EDID ←	EdidS [X1]*[X4] ↵	Store the EDID of output [X1] into EDID memory location [X4] (65 or 66)
View/Read EDID in Hex	[Esc]R EDID ←	[X5] ↵	Read out EDID in Hex from currently selected EDID
View EDID native resolution	[Esc]N EDID ←	[X6] ↵	Resolution and refresh rate of currently selected EDID <i>Example: 1600x1200@60Hz</i>
Import EDID to user slot	[Esc]I [X4], filename EDID ←	EdidI [X4] ↵	Import EDID from <i>filename</i> into specified user slot [X4] = 65 or 66
Upload EDID file to unit	[Esc]+U <i>file size, filename</i> ←	Up1↵	
Export EDID to file	[Esc]E [X4], filename EDID ←	EdidE [X4] ↵	Export EDID from specified EDID table slot to <i>filename</i> [X4] = 1 - 66
Send file from unit to PC	[Esc] <i>filename</i> SF ←	File data (128 or 256 bytes)	Send <i>filename</i> from unit to connected PC

Command	ASCII Command (host to unit)	Response (unit to host)	Additional Description
NOTE: <i>filename</i> can optionally carry a full path name. The EDID file format is .bin, carrying 128 or 256 bytes of binary data.			
IP Configuration/Setup			
Set date/time	Esc [X15]CT ←	Ipt[X15]↵	
View date/time	Esc CT ←	[X15]↵	
Set DHCP mode	Esc [X2]DH ←	Idh[X2]↵	
View DHCP mode	Esc DH ←	[X2]↵	
Set IP address	Esc [X16]CI ←	Ipi[X16]↵	Default = 192.168.254.254
View IP address	Esc CI ←	[X16]↵	
View MAC address	Esc CH ←	Iph[X17]↵	Verbose mode 2/3
Set subnet mask	Esc [X18]CS ←	Ips[X18]↵	Default = 255.255.0.0
View subnet mask	Esc CS ←	[X18]↵	
Set gateway IP address	Esc [X16]CG ←	Ipg[X16]↵	Default = 0.0.0.0
View gateway IP address	Esc CG ←	[X16]↵	
Set DNS server IP address	Esc [X16]DI ←	Ipd[X16]↵	Default = 0.0.0.0
View DNS server IP address	Esc DI ←	[X16]↵	
Get number of connections	Esc CC ←	{Number of connections}↵	
Set admin password	Esc [X19]CA ←	Ipa•[X19]↵	
Clear admin password	Esc •CA ←	Ipa•↵	
View admin password	Esc CA ←	[X19]↵	
Set user password	Esc [X19]CU ←	Ipu•[X19]↵	
Clear user password	Esc •CU ←	Ipu•↵	
View user password	Esc CU ←	[X19]↵	
RS-232 Insertion Port Setup			
Enable output RS-232 port	Esc 0[X1]*ØLRPT ←	Lrpt0[X1]*Ø↵	Set RS-232 to pass through (default) [X1] = 1 - 4 (DA4) or 1 - 8 (DA8)
Enable output UART port	Esc 0[X1]*1LRPT ←	Lrpt0[X1]*1↵	Set RS-232 to Ethernet insertion
Set all ports	Esc 0[X10]*LRPT ←	Lrpt0[X10]↵	Set all ports to pass through or Ethernet insertion
View Insertion Port Setup			
View output insert setting	Esc 0[X1]LRPT ←	[X10]↵	View port setting [X1] = 1 - 4 (DA4) or 1 - 8 (DA8)

Command	ASCII Command (host to unit)	Response (unit to host)	Additional Description
View all output insert port setting	Esc OLRPT ←	X10 ¹ X10 ² X10 ³ ... X10 ⁿ ← Lrpt000* X10 ¹ X10 ² ... X10 ⁿ ←	Verbose mode 2/3
Serial Port Configuration			
Set serial port parameters	Esc X57 * X58 , X59 , X60 , X61 CP ←	Cpn X57 •Ccp X58 , X59 , X60 , X61 ←	
Query serial port parameters	Esc X57 CP ←	X58 , X59 , X60 , X61 ←	Read port parameters
Configure current port timeout	Esc 0* X64 TC ←	Pti0* X64 ←	Set timeout
View current port timeout	Esc 0TC ←	X64 ←	View timeout
Configure global port timeout	Esc 1* X64 TC ←	Pti1* X64 ←	
View global port timeout	Esc 1TC ←	X64 ←	
Set UART start point	Esc X65 *MD ←	Pmd X65 ←	Default = 1999 Output 1 uses 2001 Output 8 uses 2008
Query UART start point	Esc MD ←	X65 ←	Read start point for UART
Unit Name			
Set unit name	Esc X8 CN ←	Ipn• X8 ←	X8 = Up to 24 alphanumeric characters, including "-"
Set unit name to factory default	Esc •CN ←	Ipn•{Default} ←	<i>Example:</i> DTP-HD-DA8-4K-330-0B-4A-45 (Model name and last 3 pairs of MAC address)
View unit name	Esc CN ←	X8 ←	
Other			
Set verbose mode	Esc X14 CV ←	Vrb X14 ←	In modes 2 and 3, all "view" commands return the prefix and the value, just as the "set" commands do
Query verbose mode	Esc CV ←	X14 ←	
Query DTP mode	Esc 0HDBT ←	X13 • X13 • X13 X13 ←	This command returns the rear panel DTP/HDBaseT switch status
Request part number	N/n	60-1437-01 ← 60-1438-01 ← 60-1437-51 ← 60-1438-51 ←	DTP HD DA4 4K 230 DTP HD DA8 4K 230 DTP HD DA4 4K 330 DTP HD DA8 4K 330
Query firmware version	Q/q	X7 ←	
Query firmware version with build	*Q/q	x.xx.xxxx ←	Firmware build
Reset settings (retain IP settings)	Esc ZXXX ←	Zpx ←	
Reset all settings (including IP settings)	Esc ZQQQ ←	Zpq ←	

Command	ASCII Command (host to unit)	Response (unit to host)	Additional Description
View HDCP Notifications			
Set green screen	Esc N 0 HDCP ←	HdcpN 0 ←	X67 = 0 = Green Screen (default)
Set black screen	Esc N 1 HDCP ←	HdcpN 1 ←	1 = Black Screen
View HDCP notifications	Esc N HDCP ←	X67 ← HdcpN X67 ←	Verbose 2/3

Reference Information

This section provides information about updating the firmware of the DTP HD DA 4K models. The following topics are discussed:

- [Using the Internal Web Pages](#)
- [Updating the Device Firmware](#)

Using the Internal Web Page

The DTP HD DA 4K series Internal Web Page allows for monitoring and set up of the device via an Ethernet connection.

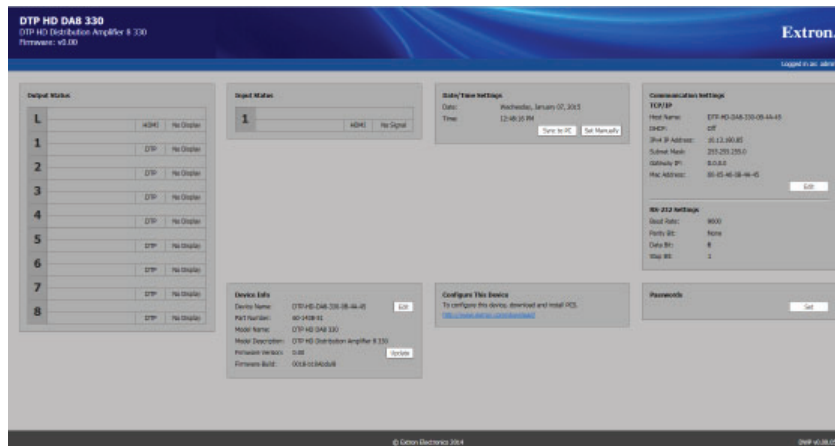

Figure 11. DTP HD DA 4K Internal Web Page

Accessing the Internal Web Page

To access the Internal Web Page:

1. Using an RJ-45 cable, connect the device to a LAN via the rear panel LAN connector (see **J** on [page 7](#)).
2. Enter the device IP address into a Web browser address bar.

Setting Up the Device with the Internal Web Page

Output status

This section displays the status of all connected outputs. This section is not configurable.

Input status

This section displays the status of the connected input. This section is not configurable.

Device info

This section displays device information including:

- **Device Name** — Displays the device name. Click the **Edit** button to configure the name.
- **Part Number** — Displays the device part number (non-configurable)
- **Model Name** — Displays the device model number (non-configurable)
- **Model Description** — Displays a description of the connected model (non-configurable)
- **Firmware Version** — Displays the current firmware version number. Click the **Update** button to load new firmware to the device (see the following section for more information)
- **Firmware Build** — Displays the current firmware build (non-configurable)

Date/Time settings

This section displays the date and time settings of the device. Click **Sync to PC** to automatically sync the time to the connected PC. Click **Set Manually** to set a desired time.

Configure this device

Click the link in this section to go to the Extron website where the Product Configuration Software (PCS) can be downloaded. For more information about PCS, see the PCS Help File, which is packaged with the software.

Communication settings

This section displays the TCP/IP and RS-232 device communications settings.

TCP/IP

If necessary, click the **Edit** button to change the TCP/IP settings.

RS-232

This section is non-configurable.

Passwords

Click the **Set** button to set up a password for the device.

Updating the Device Firmware

Update the device firmware via either the Internal Web Page or the Extron PCS software.

Downloading Firmware

To obtain the latest version of firmware for your distribution amplifier:

1. At www.extron.com, click the **Download** link at the top of the page (figure 12, ❶), then click the **Firmware** link (❷) on the left sidebar menu.

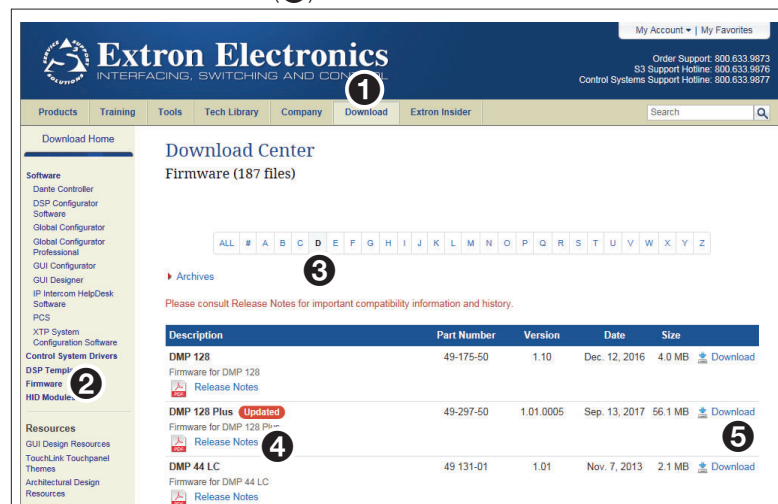

Figure 12. Firmware Link on the Download Tab

2. On the **Download Center** screen, click the letter **D** (❸).
3. Locate the necessary firmware in the list and click **Download** (❺).
4. (Optional) click **Release Notes** (❹) next to the necessary firmware. These notes show the issues that are addressed by the latest update. If these issues do not affect the current device, updating the firmware may not be necessary.
5. On the next screen that appears, enter the requested user information, then click the **Download** button.
6. Follow the instructions on the rest of the download screens to save the executable firmware file to the computer. Note the folder to which the file was saved.
7. In Windows Explorer or another file browser, locate the downloaded executable file and double-click it to run it.
8. Follow the instructions on the **Installation Wizard** screens to install the new firmware on the computer. A Release Notes file and a set of instructions for updating the firmware are also loaded.

Downloading and Installing PCS

Extron recommends using the PCS software to update the firmware on Extron products. If PCS is not already installed on the connected computer, download it as follows:

1. Go to www.extron.com and click the **Download** tab.
2. On the **Download Center** screen, click the **Software** link on the left sidebar menu.

- On the next **Download Center** screen, locate PCS and click its **Download** link.

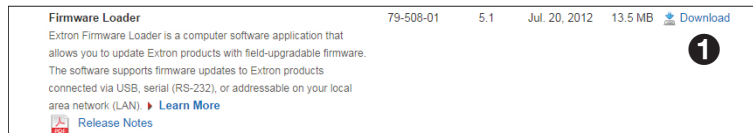

Figure 13. PCS Download Link

- On the next screen, enter the requested information, then click the **Download PCS_vnxn.exe** button (where n is the PCS version number).
- Follow the instructions on the rest of the download screens to save the executable PCS installer file to the computer. Note the folder to which the file was saved.
- In Windows Explorer or another file browser, locate the downloaded executable installer file and double-click it to open it.
- Follow the instructions on the Installation Wizard screens to install PCS on the computer. Unless you specify otherwise, the installer program places the PCS file, **FWLoader.exe**, at **c:\Program Files\Extron\Extron PCS**.

Loading Firmware to the DA with PCS

To load a new version of firmware to the distribution amplifier using PCS, follow these instructions.

- If not already installed, download and install the PCS executable installer file to the computer (see **Downloading and Installing PCS** on the previous page).
- If necessary, download the latest version of firmware for the desired product (see **Downloading Firmware** on the previous page).
- Connect the distribution amplifier to the computer using the front panel USB connector (**B** on page 5), the rear panel LAN connector (**J** on page 7), or the rear panel RS-232 connector (**K** on page 8).
- Open Firmware Loader. If there is no desktop icon, open the program from the Start menu by selecting:
Start > All Programs > Extron Electronics > Extron Product Configuration Software > Product Configuration Software
 The PCS dialog box opens with the **Add Device...** dialog box in front of it.

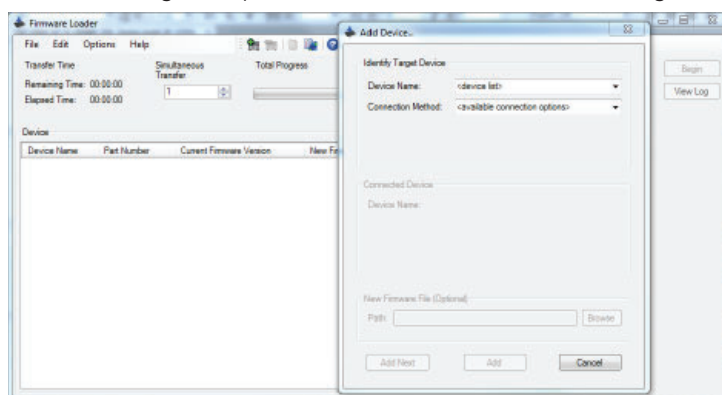

Figure 14. Opening PCS

- Select the **DTP HD DA 4K** product from the **Device Name** menu.
- Select **RS-232**, **USB**, or **TCP/IP** from the **Connection Method** menu.

7. Depending on the connection method that selected, additional options appear. Make the appropriate selections for the connection method.
 - **RS-232:** Select the appropriate options from the Com Port and Baud Rate menus.
 - **USB:** Only the Extron USB Device_0 option is available on the Available Devices menu. Make sure that it is selected.
 - **TCP/IP:** Enter the IP address (default is 192.168.254.254), port number, and password (if necessary).
8. Click **Connect**. If the connection is successful, DTP HD DA4 4K 230/330 or DTP HD DA8 4K 230/330 is displayed in green in the **Connected Device** panel, followed by a green check mark.
9. Click **Browse** to locate the Firmware file that was downloaded in step 2.

ATTENTION:

- Valid firmware files must have the file extension S19. A file with any other extension is not a firmware upgrade for this device and could cause the device to stop functioning.
- Les fichiers firmware valides doivent contenir l'extension fichier S19. Un fichier avec n'importe quelle autre extension n'est pas une mise à jour de firmware pour cet appareil et l'appareil pourrait arrêter de fonctionner.

NOTES:

- The original factory-installed firmware is permanently available on the DA units. If the attempted firmware upload fails for any reason, the unit reverts to the factory version.
- By default, when the firmware is downloaded from the Extron site, it is saved in one of the following paths:
 C:\Program Files\Extron\Firmware*folder_name* (Windows XP) or
 C:\Program Files (x86)\Extron\Firmware*folder_name* (Windows 7) where *folder_name* may be named for the specific model needed.

10. If multiple units are connected to the computer, it is possible to upload the same firmware to all of them simultaneously. Click **Add Next**.
 The first device is added to the **Devices** section and the **Add Device...** dialog box remains open. Add additional devices, by repeating this step.
 When adding the last device, (or if only updating a single unit) click **Add** (do not press Add Next). The device is added to the device list in the **Firmware Loader** window and the **Add Device...** dialog box closes.
11. Highlight the distribution amplifier in the device list and click **Begin**. The following indicators show the progress of the update:
 - The **Transfer Time** section shows the amounts of remaining and elapsed time for the update.
 - The **Total Progress** section displays a progress bar with **Uploading...** above it.
 - In the **Devices** section, the **Progress** column displays an incrementing percentage and another progress bar. The **Status** column displays **Uploading**.
12. The upload is complete when the **Remaining Time** field shows 00.00.00, the **Progress** column shows 100%, and **Completed** is displayed above the progress bar and in the **Status** field. Close the **Firmware Loader** software.

Loading Firmware to the DA with Internal Web Page

The firmware can also be updated via the DTP HD DA 4K internal web page.

To update the firmware via the internal web page:

1. Using an internet browser, navigate to the device Internal Web Page.
2. In the **Device Info** section, click the **Update** button.

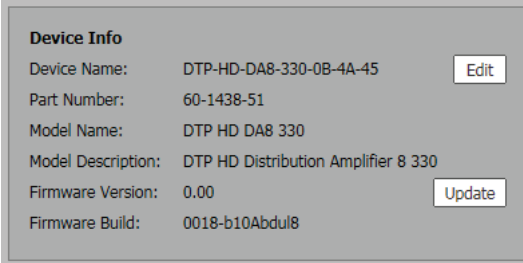

Device Info		
Device Name:	DTP-HD-DA8-330-0B-4A-45	<input type="button" value="Edit"/>
Part Number:	60-1438-51	
Model Name:	DTP HD DA8 330	
Model Description:	DTP HD Distribution Amplifier 8 330	
Firmware Version:	0.00	<input type="button" value="Update"/>
Firmware Build:	0018-b10Abdul8	

Figure 15. Device Info Section

3. Click the **Browse** button and locate and select the desired firmware file, then click **Open**.
4. Click the **Upload** button.

Extron Warranty

Extron Electronics warrants this product against defects in materials and workmanship for a period of three years from the date of purchase. In the event of malfunction during the warranty period attributable directly to faulty workmanship and/or materials, Extron Electronics will, at its option, repair or replace said products or components, to whatever extent it shall deem necessary to restore said product to proper operating condition, provided that it is returned within the warranty period, with proof of purchase and description of malfunction to:

USA, Canada, South America,

and Central America:
Extron Electronics
1230 South Lewis Street
Anaheim, CA 92805
U.S.A.

Japan:

Extron Electronics, Japan
Kyodo Building, 16 Ichibancho
Chiyoda-ku, Tokyo 102-0082
Japan

Europe and Africa:

Extron Europe
Hanzeboulevard 10
3825 PH Amersfoort
The Netherlands

China:

Extron China
686 Ronghua Road
Songjiang District
Shanghai 201611
China

Asia:

Extron Asia Pte Ltd
135 Joo Seng Road, #04-01
PM Industrial Bldg.
Singapore 368363
Singapore

Middle East:

Extron Middle East
Dubai Airport Free Zone
F13, PO Box 293666
United Arab Emirates, Dubai

This Limited Warranty does not apply if the fault has been caused by misuse, improper handling care, electrical or mechanical abuse, abnormal operating conditions, or if modifications were made to the product that were not authorized by Extron.

NOTE: If a product is defective, please call Extron and ask for an Application Engineer to receive an RA (Return Authorization) number. This will begin the repair process.

USA: 714.491.1500 or 800.633.9876

Asia: 65.6383.4400

Europe: 31.33.453.4040

Japan: 81.3.3511.7655

Units must be returned insured, with shipping charges prepaid. If not insured, you assume the risk of loss or damage during shipment. Returned units must include the serial number and a description of the problem, as well as the name of the person to contact in case there are any questions.

Extron Electronics makes no further warranties either expressed or implied with respect to the product and its quality, performance, merchantability, or fitness for any particular use. In no event will Extron Electronics be liable for direct, indirect, or consequential damages resulting from any defect in this product even if Extron Electronics has been advised of such damage.

Please note that laws vary from state to state and country to country, and that some provisions of this warranty may not apply to you.