

# INSTRUCTION MANUAL

---

## INSTALLATION - OPERATION - MAINTENANCE

**HCV-5HA Vacuum Contactor, 7.2kV – 400A – 7.0kA (4.5kA@7.2kV)**  
**HCV-5HAL Vacuum Contactor, 7.2kV – 400A – 7.0kA (4.5kA@7.2kV)**

Issued: 4/20

Manufactured in the USA



**READ THIS MANUAL** carefully for important information about safety, handling, and maintenance, for general-purpose NEMA Class E magnetic controllers.

This manual and all accompanying drawings should be considered a permanent part of the equipment. They should be readily available for review and reference at all times.

**DIMENSIONS** shown in the manual are in metric and/or their English equivalent.

These instructions are not intended to cover all details, combinations, or variations of the equipment, storage, or installation.

**PROBLEMS OR QUESTIONS** should be addressed to:

Field Service Department  
Toshiba International Corporation  
13131 West Little York Road  
Houston, Texas 77041 USA  
Telephone: (713) 466-0277  
(800) 231-1412  
(800) 527-1204 (Canada)  
FAX: (713) 466-8773

**▲ WARNING**

Use only Toshiba-authorized replacement parts.

**▲ WARNING**

This equipment is designed and built in accordance with applicable safety standards in effect on the date of manufacture. Unauthorized modifications can result in severe injury, death and property damage. Do not make any modifications to this equipment without the written approval of Toshiba.

	<b>Page</b>		<b>Page</b>
<b>SAFETY DATA</b>	<b>4</b>	<b>MAINTENANCE</b>	<b>17</b>
Safety Data Information	4	General Inspection	17
		Vacuum Interrupter	18
		Bearing	19
<b>GENERAL</b>	<b>6</b>	Closing Coils	19
Recommended Procedure	6	Latch Mechanism	19
		Auxiliary Switch	19
<b>RECEIVING &amp; HANDLING</b>	<b>7</b>	<b>TROUBLESHOOTING</b>	<b>20</b>
Receiving	7		
Handling	7	<b>OUTLINE DIAGRAM</b>	<b>21</b>
Storage	7		
<b>GENERAL DESCRIPTION</b>	<b>8</b>		
Application	8		
Load Data	8		
Location Condition	8		
Ratings	9		
Construction	10		
<b>PRE-OPERATION SET-UP</b>	<b>11</b>		
Application Precautions	11		
Installation	11		
Controls	12		
Power Connections-Standard	13		
Power Connections-Latched	13		
Drive Unit Configuration	14		
Standard Circuit Diagram	14		
Latched Circuit Diagrams	15		
Trial Operation	16		

**QUALIFIED OPERATORS ONLY**

Only qualified persons are to install, operate, or service this equipment according to all applicable codes and established safety practices.

A qualified person must:

- 1) Carefully read the entire instruction manual.
- 2) Be skilled in the installation, construction or operation of the equipment and aware of the hazards involved.
- 3) Be trained and authorized to safely energize, de-energize, clear, ground, lockout and tag circuits in accordance with established safety practice.
- 4) Be trained and authorized to perform the service, maintenance or repair of this equipment.
- 5) Be trained in the proper care and use of protective equipment such as rubber gloves, hard hat, safety glasses, face shield, flash clothing, etc. in accordance with established practices.
- 6) Be trained in rendering first aid.

**SAFETY CODES**

Toshiba medium voltage controllers are general purpose, Class E, magnetic controllers designed and built in accordance with the latest applicable provisions of NEMA ICS 3 Part 2, UL 347 and the National Electrical Code. Installations must comply with all applicable state and local codes, adhere to all applicable National Electric Code (NFPA 70) standards and instructions provided in this manual.

**IMPORTANT MESSAGES**

Read this manual and follow its instructions. Signal words such as **DANGER**, **WARNING**, **CAUTION**, and **NOTE** will be followed by important safety information that must be carefully reviewed.

**▲ DANGER**

Indicates a situation which will result in death, serious injury, and severe property damage if you do not follow instructions.

**▲ WARNING**

Means that you might be seriously injured or killed if you do not follow instructions. Severe property damage might also occur.

**▲ CAUTION**

Means that you might be injured if you do not follow instructions. Equipment damage might also occur.

**NOTE** Gives you helpful information.

**READ SAFETY SIGNS**

To avoid injury, you must read and follow the instructions in this manual and on the safety signs located on the equipment.

Keep the safety signs visible and in good shape.  
Never remove, damage, or cover any safety sign.

Please read this manual and all accompanying documentation in its entirety prior to installation and operation. These instructions are not intended to cover all details, combinations or variations of the equipment, storage or installation.

Toshiba medium voltage vacuum contactors are UL recognized and built in accordance with the latest applicable provisions of NEMA ICS 3 Part 2, UL 347 and the National Electrical Code.

<b>▲ WARNING</b>
<b>There is a hazard of shock or burn whenever working on or near electrical equipment.</b>
<b>ALL POWER supplying the equipment should be turned off before starting work, and disconnecting means should be locked out and/or tagged out in accordance with NFPA 70 E, NFPA 70 E, Part II and ANSI Z244.1</b>

Where it is not feasible to de-energize the unit, the following precautions should be taken;

- A. Persons working near exposed parts that are or may be energized should be instructed to and should use practices (including appropriate apparel, equipment and tools) in accordance with NFPA 70 E, Part II.
- B. Persons working on exposed parts that are or may be energized should, in addition to A, be qualified persons who have been trained to work on energized equipment.

### RECOMMENDED PROCEDURE

The successful and safe operation of medium voltage control equipment is dependent upon handling, installation, operation and maintenance by qualified personnel. Failure to follow fundamental installation and maintenance recommendations could lead to personal injury and damage to the equipment and other property. When referred to in this manual and on product labels, a qualified person is one who is familiar with installation, construction or operation of the equipment and the hazards involved. In addition, this person should have the following qualifications;

- 1) Is trained and authorized to energize, de-energize, clear, ground and tag circuits in accordance with established safety practices.
- 2) Is trained in the proper care and use of protective equipment such as rubber gloves, hard hat, safety glasses or face shields, flash clothing, etc. in accordance with established practices.
- 3) Is trained in rendering first aid.

**KEEP THESE INSTRUCTIONS FOR FUTURE REFERENCE**

**RECEIVING**

Upon receipt of the equipment, make an immediate inspection for any damages which may have occurred during shipment. When the contactor is received it should be unpacked sufficiently to inspect for concealed damage and to determine that the shipment is complete and correct. If any damage is found it should be noted prior to accepting the shipment if possible.

Check for things such as, damage to the container, water seepage or moisture on the contactor. Check the nameplate to confirm that the ratings meet the intended application.

If any parts are damaged or missing, file a claim immediately with the carrier and notify the Toshiba sales office. Try to give as much information as possible when filing a claim.

**HANDLING & STORAGE**

Vacuum contactors should be handled with care to avoid damage. Contactors should be kept in an upright position and moved with suitable equipment.

If the contactor is to be stored over any length of time, the packing material should be restored for protection during that period. Where conditions permit, the packing should be left intact until the contactor is ready for installation. Store the contactor in a dry and dust free area. It should not be left outdoors or in adverse conditions. If unprotected, corrosion, rust and insulation deterioration will occur.

**SERVICE CONDITIONS**

**Application Condition**

The type HCV vacuum contactor is manufactured in accordance with IEC 60470 (1974), NEMA ICS 3 Part 2 (1993). The vacuum contactor should be used in the following conditions.

**Table 1  
Normal Service Conditions**

- Altitude:	Less than 2,000 m (6600 ft) Above 2,000 m consult factory
-Ambient temperature:	-5°C min. to +40°C max. Its average over a period of 24 hr does not exceed +35°C.
-Relative humidity:	45% min. to 85% max.
-Vibration:	20 Hz - 1G or less
-Shock	30G
-Weight	43 lbs. Latched type 44 lbs.

If the contactor is to be used in conditions other than those specified above, please consult Toshiba International Corporation.

**Table 2  
General Application and Load Data**

System Voltage	0.8PF Ind/Syn Motor	1.0PF Syn Motor	3 Phase Transformer	3 Phase Capacitor
2.2-2.5kV	1750HP	2000HP	1500kVA	1500kVAR
3.0-3.3kV	2250HP	2500HP	2000kVA	2000kVAR
4.0-5.0kV	3000HP	3500HP	3000kVA	2000kVAR
6.0-6.6kV	4500HP	5000HP	4000kVA	2000kVAR

The above table is based on general load data and standard application. Lower limitations may apply on specific applications (i.e. applications above 6600 feet elevations).

**Location condition**

The location where the contactor is to be installed should be free from dust, corrosive gas and moisture. When it is to be used in a chemical plant or in outdoor applications, take necessary precautions against corrosion, water seepage and condensation.

**CONTACTOR RATINGS**

**HCV-5HA**

Rated Voltage	7200 Volts
Rated Current	400 Amps
Interrupting Capacity	7000A RMS Symmetrical @5000V Max. 4500A RMS Symmetrical @7200V Max.
Permissible Switching Frequency	1200/Hour
Mechanical Life	2,500,000 Operations
Electrical Life	250,000 Operations
Closing Time *	50 - 90 ms
Opening Time *	15 - 40 ms
Arcing Time	10 ms or less
Pick-Up Voltage AC or DC (Max.) *	85% Rated (Hot) - 70% Rated (Cold)
Drop-Out Voltage AC or DC (Max.) *	70% Rated (Hot) - 60% Rated (Cold)
Rated Control Voltage AC	115/120 or 230/240 V 50/60 Hz
Rated Control Voltage DC	120/125 or 240/250 V
Coil Circuit Inrush	670 VA AC (700 W DC)
Coil Circuit Holding	85 VA AC (85 W DC)
Auxiliary Contact Arrangement	3 N.O. - 3 N.C.
Auxiliary Contact Rating	10 A, 600 V (NEMA Class A600)

\* These are typical values measured under the following conditions:

- a) No external devices connected to the mechanism.
- b) At sea level.
- c) 120Vac control power applied to terminals 1 & 2.
- d) Contactor controlled (open/close) via terminals 3 & 4.

**HCV-5HAL (Latched Type Only)**

Permissible Switching Frequency	300/Hour
Mechanical Life	250,000 Operations
Tripping Voltage	40-60% Rating DC
Tripping Current	4.8 A DC Max

Fig. 1 Construction of HCV-5HA & HCV-5HAL

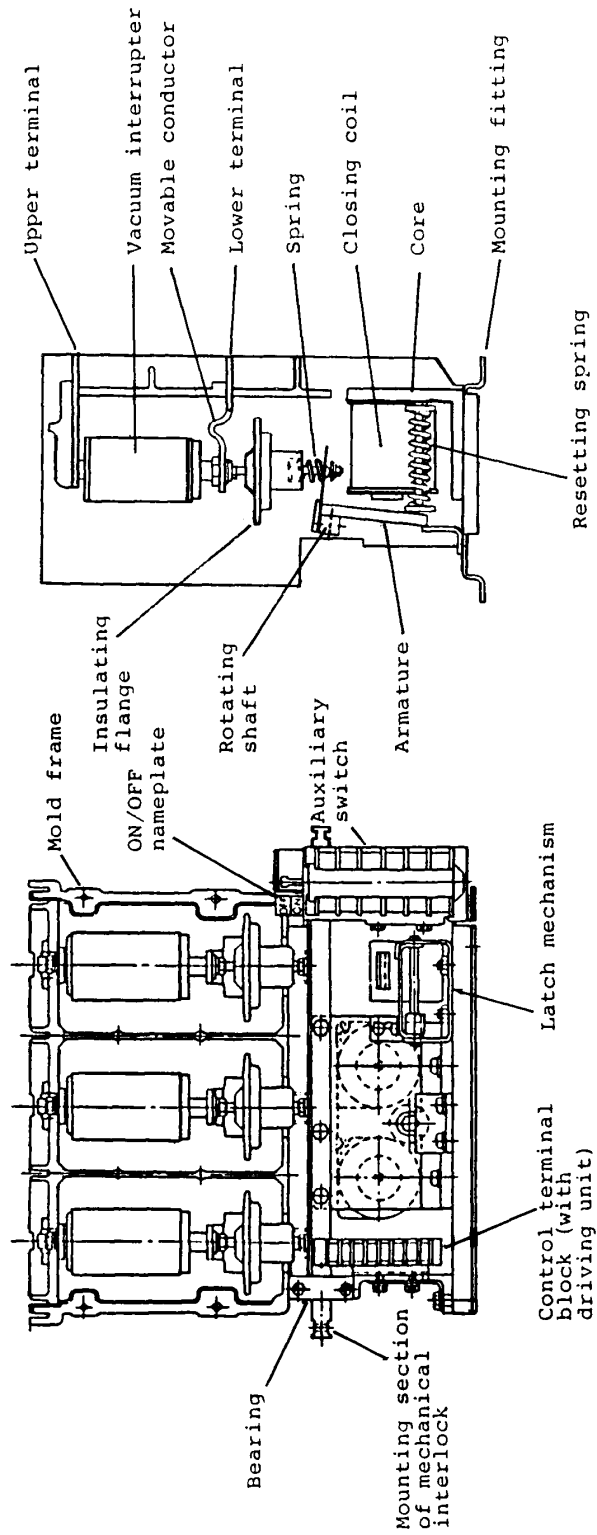

**APPLICATION PRECAUTIONS**

- 1) Verify that the voltage and current applied is within the specified ratings. (See application table, page 5).
- 2) When the contactor is used with an induction heater facility, the switching life of the vacuum interrupter is approximately 250,000 operations. The vacuum interrupter should be replaced after 250,000 operations.
- 3) When the contactor is applied to a capacitor load, be sure to use a space heater to keep the temperature above the dew point and prevent condensation. Be sure to use a heater adequately sized for the compartment in which the contactor is installed. The contactor should always be applied with a protective power fuse.

**INSTALLATION**

During installation, protect the contactor from dust and falling debris.

The following precautions should be taken,

- 1) The mounting surface should be horizontal (level:  $\pm 1$  mm). If the mounting surface is not level, adjust with spacers or shims.
- 2) The contactor base has four (4) mounting holes. Use M8 or 5/16 bolts to securely mount the contactor.
- 3) In wiring the main circuit, wires should be given sufficient length to be flexible for service. The ground wires should be #10 AWG or larger.
- 4) Avoid touching the surface of the vacuum interrupter with soiled hands. You can damage the silicon finish on the interrupter. If the interrupter becomes dirty, simply clean it with a non-tracking cleaner such as rubbing alcohol.

**CONTROLS**

The drive unit for the closing coil assembly is installed in a cavity in the molded frame housing. The closing circuit can be operated by applying either AC or DC to this drive unit. The optional latch trip circuit uses DC as standard. When a latched contactor is operated using AC power, it is recommended that a capacitor trip device be used.

The standard control voltage (factory preset) is 120V AC. To operate at other ratings see the selection chart below.

**Fig. 2 Control Voltage Selection for Closing Coils**

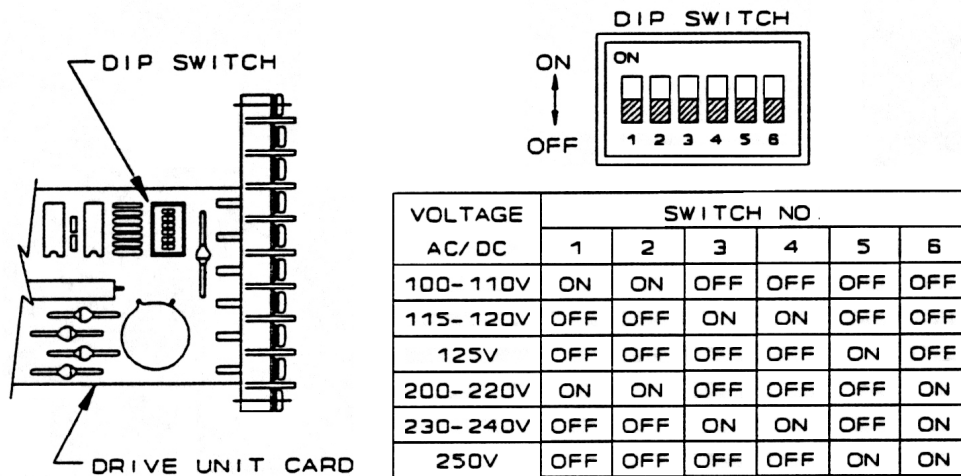

The following is a list of the available trip coil voltages for a latched type contactor:

24 V DC  
125 V DC

32 V DC  
250 V DC

48 V DC

CONNECTION OF CONTROL POWER SUPPLY

Figures 3 and 4 show the internal connections of the magnetically held (normally energized) type and the latched type respectively. Connect control power and open/close control signals according to these connection diagrams.

Note: Connections are the same for 100V and 200V class. Only the drive unit settings should be changed to match the application control voltage.

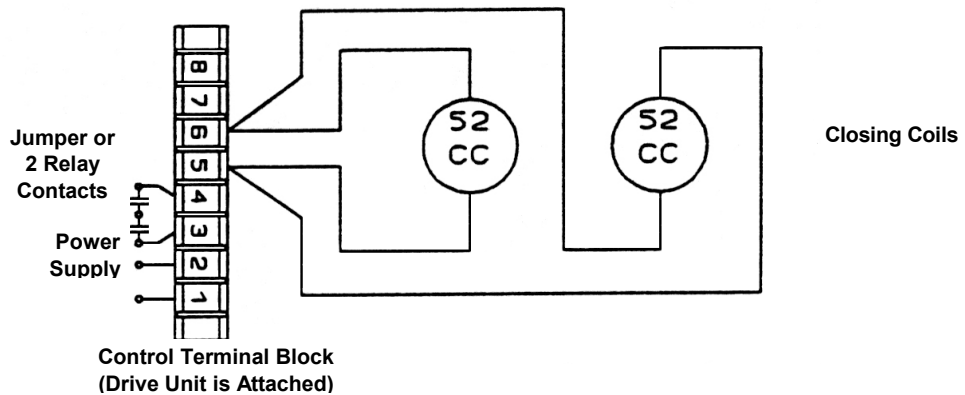

Fig. 3 Connections for Magnetically Held Type.

Note: Terminals 3 and 4 are rated for 4.8A DC max. A wire jumper (14 AWG or larger) can be used instead of a relay on 3 and 4.

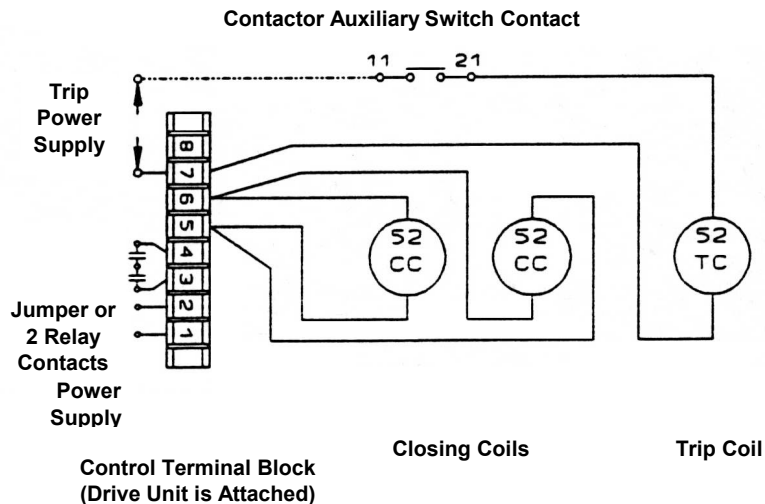

Fig. 4 Connections for Mechanically Latched Type.

Note: Terminals 3 and 4 are rated for 4.8A DC max. A wire jumper (14 AWG or larger) can be used instead of a relay contact on 3 and 4.

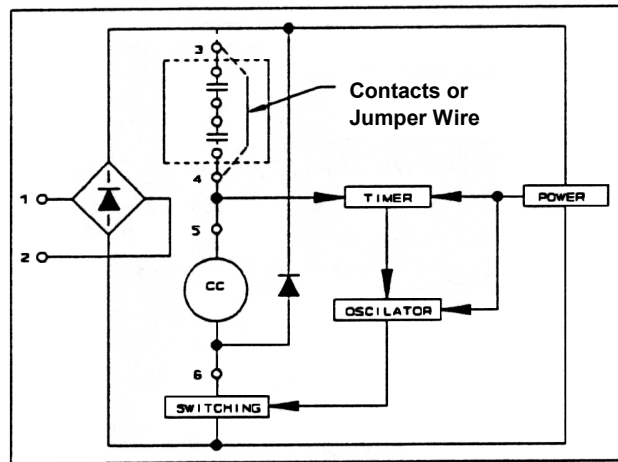

Fig. 5 Internal Configuration of Drive Unit.

STANDARD OPERATION CIRCUIT

The following figures illustrate the vacuum contactor and its auxiliary circuits (control and monitoring). Fig. 6 represents the standard operation circuit diagram of the normally energized type and Fig. 7 (a & b) the latched type. Wiring should be implemented according to these circuit diagrams.

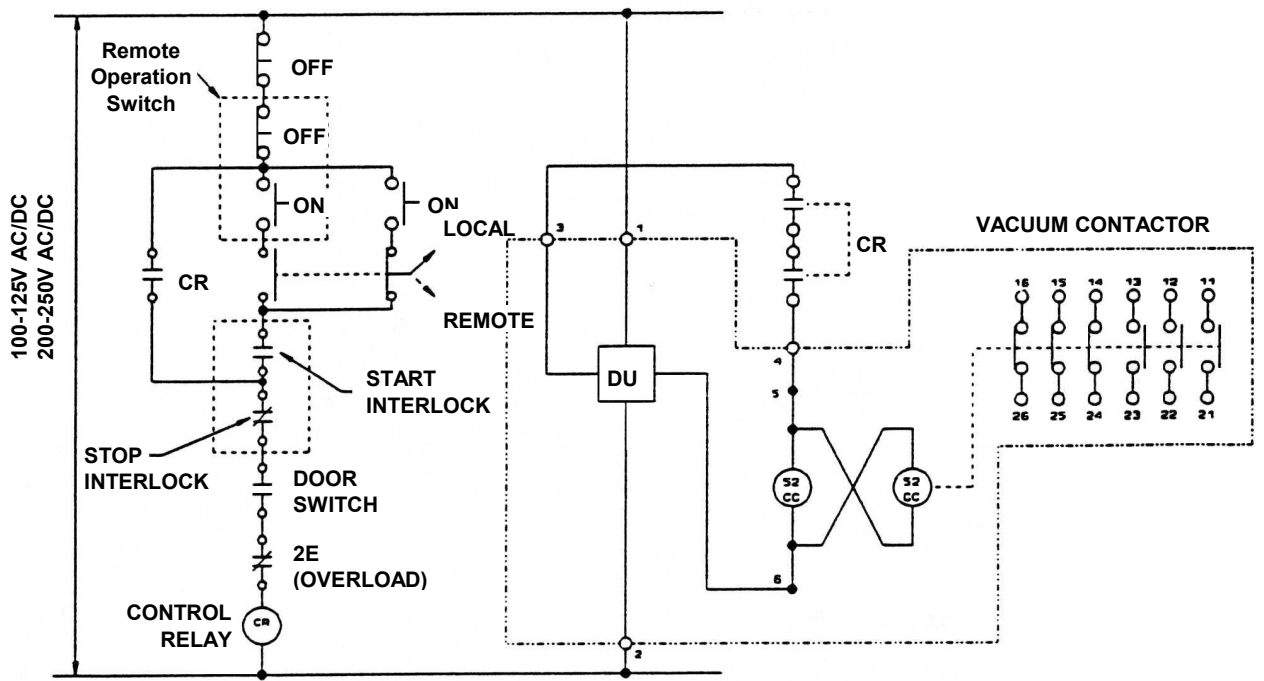

Fig. 6 Standard Operation Circuit Diagram of Normally Energized Type.



## TRIAL OPERATION

**WARNING** MAKE SURE MAIN POWER IS OFF.

After mounting and wiring of the vacuum contactor, make the following inspections.

- 1) Check for any loose connections.
- 2) Check for any wiring errors. Perform this test with only the control circuit energized.

Confirm that the operation is correct. For the latched type contactor, check that the latch correctly engages and trips when the close/trip signals are applied. Also, manually trip the contactor using the trip lever to verify proper operation. For latch kit adjustment and maintenance please refer to manual no. 6F9G0132 - Installation Instructions of Latch Kits for HCV-5HA.

**GENERAL INSPECTION**

**MAINTENANCE AND INSPECTION**

The following maintenance and inspections are recommended to maintain the performance level and extend the operational life of the vacuum contactor.



**BEFORE CONDUCTING MAINTENANCE AND INSPECTIONS, MAKE SURE THAT ALL POWER IS TURNED OFF.**

**Table 3 Items for Inspection**

PARTS TO BE INSPECTED	INSPECTION ITEM	CRACKS	DISCOLORATION	CONTAMINATION	RUST	WEAR	LOOSE PARTS	INCOMPLETE OPERATION	VIBRATION SOUND	INSPECTION INTERVALS
MAIN CIRCUIT	VACUUM INTERRUPTER			○	○	○			○	VISUAL CHECK ONCE A YEAR OR EVERY 20,000 OPERATIONS
	MOVABLE CONDUCTOR	○	○							
	UPPER & LOWER TERMINALS		○				○			
MECHANISM SECTION	MOLDED FRAME	○	○	○						
	INSULATION FLANGE	○					○			
	BEARING					○	○			
ELECTRO-MAGNET	CLOSING COIL		○							
	ARMATURE & CORE				○		○			
	AUXILIARY SWITCH	○	○				○			
LATCH MECHANISM	TRIP COIL		○							
	ROLLER	○				○	○	○		
OTHERS	BOLTS & NUTS						○			
	INSULATION WIRE	○								
NOTE	THE LIFE EXPECTANCY OF THE ELECTRICAL PARTS (VACUUM INTERRUPTER, AUXILIARY SWITCH) IS 250,000 OPERATIONS									

**▲ WARNING** Make Sure Power Is Turned Off.

**MAINTENANCE**

Location	Maintenance Procedure
<p>Vacuum Interrupter</p>	<ul style="list-style-type: none"> <li>▪ Check the upper and lower flanges and interrupter shaft to see if they are contaminated or corroded.</li> </ul> <p>If contaminated, use a clean cloth and rubbing alcohol.</p> <p>If corroded, replace with a new interrupter.</p> <p><b>NOTE:</b> Avoid touching the ceramic surface. Skin oils may harm the silicon varnish.</p> <ul style="list-style-type: none"> <li>▪ Check the main contact wear in the vacuum interrupter.</li> </ul> <p>If the wear gauge can be inserted, then there is sufficient contact material available for continued use.</p> <p>If the gauge cannot be inserted, replace the interrupter.</p> <p><b>NOTE:</b> This check is made with the contactor closed.</p> <ul style="list-style-type: none"> <li>▪ Check vacuum in the vacuum interrupter.</li> </ul> <p>Apply 10kVAC between the upper and lower terminals for one minute.</p> <p>If there is no voltage breakdown, the vacuum interrupter is acceptable for continued use.</p> <p>If there is voltage breakdown, replace with a new vacuum interrupter before continued use.</p> <p><b>NOTE:</b> If there is a vacuum failure, it can be confirmed by pushing down on the insulating flange below the vacuum interrupter. If the interrupter shaft can easily be moved, then the interrupter has lost vacuum.</p>

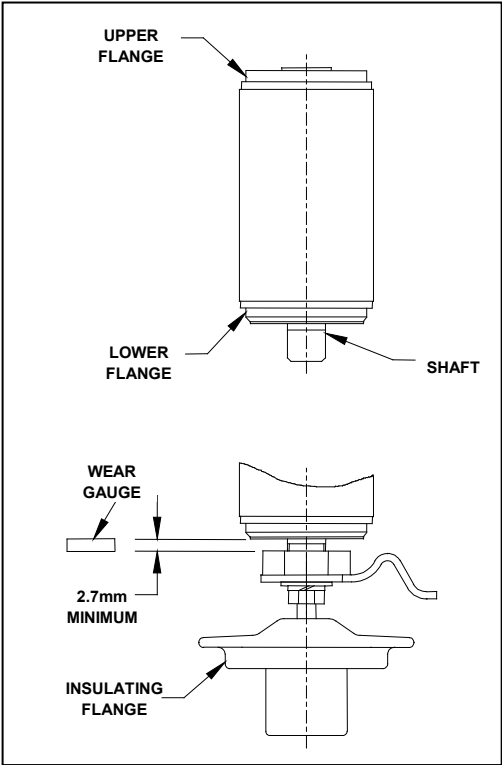

Location	Maintenance Procedure			
Vacuum Interrupter	<b>Gap/Wipe Standard Values (contactor in new condition)</b>			
	Contactor	Contact Gap	Wipe (new)	Allowable Wear
	Normally Energized Type	4.0-4.2mm	>2.3mm	1.8mm
Latched Type	4.0-4.2mm	>2.1mm	1.6mm	
Bearing	* Check for loose mounting bolts. Tighten if loose. Torque M6 bolts to 48 in-lb.			
Closing Coil	* Check for discoloration. Yellow (Gold) ..... available for continued use. Dark Brown or Black ..... replace with new coil. If the closing coil is overheating, contact Toshiba.			
Latch Mechanism	* Check that the holding latch reliably engages. Note: To manually close the latch, hold the central area of the rotating shaft with a wrench and operate it. * Check the condition of the roller. It should be smooth. * Lubricate the rotating parts with a molybdenum disulfide or gear lubricant.			
Auxiliary Switch	* Verify that there is remaining auxiliary shaft travel. Approximately 2.3 - 2.5mm.			
	* Check for burnt or worn contacts. Replace if burnt or worn.			
	* Check if auxiliary switch is mounted at an incline or if mounting plate is loose. If inclined or loose, correct it.			
	<b>(Reference) Values for gap and wipe</b>			
	Contact Type	Contact Gap	Wipe	
Normally Open Contact	4mm +/- 0.4	3mm +/- 0.3		
Normally Closed Contact	4mm +/- 0.4	3mm +/- 0.3		
Delayed N.C. Contact (For latched type contactor only. Contacts 16-26)	2.5mm +/- 0.3	4.5mm +/- 0.5		

## TROUBLESHOOTING

Turn off main power before any inspections are conducted.

Table 4 Trouble Shooting Procedure

SYMPTOM					SOURCE OF TROUBLE/PROBLEM	SOLUTION
Contactor does not close.	Contactor does not open (Latch type).	Trip coil overheated.	Closing coil overheated.	Latch does not engage.	Conduct investigation with main power "OFF".	If inspection and/or countermeasure is difficult, inform Toshiba immediately.
0	0			0		
0	0	0	0	0	Control power supply is low.	Lower the voltage drop to increase the voltage to 90% or more of the rating.
0	0				Incorrect control voltage.	Apply proper rating.
0	0				Defective control circuit.	Check connection diagram.
0	0			0	Bad connection and/or loose connection.	Make proper connection.
0	0				Bad control switch contact.	Clean or replace device.
0	0			0	Incorrect terminal connection.	Connect correctly.
0				0	Blown power supply fuse(s).	Remove cause of fault and replace fuse(s).
0	0				Disconnected coil.	Survey cause and reconnect coil.
0			0		Faulty drive unit.	Replace drive unit.
0			0	0	Defective latch mechanism.	Excite closing coil and check latch hook.
0				0	Mechanism jammed.	Lubricate corresponding portion.
		0			Incorrect auxiliary adjustment.	Adjust delayed N.C. contact gap to 2.5mm +/- 0.3mm when connected.
	0				Bad auxiliary contact.	Clean or replace auxiliary contact block.

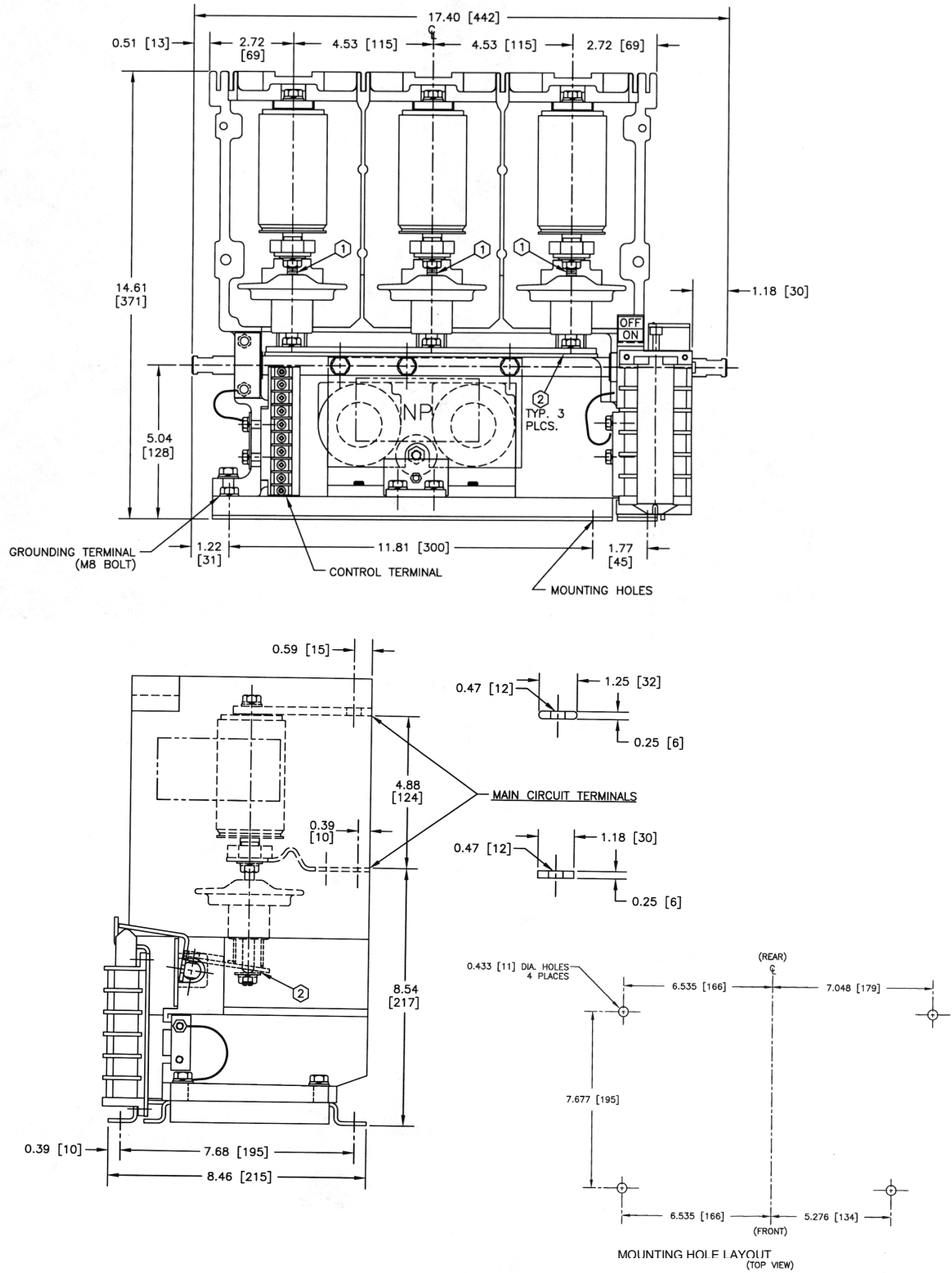

Fig. 12 Types HCV-5HA, HCV-5HAL

# **TOSHIBA**

**TOSHIBA INTERNATIONAL CORPORATION**

Motors and Drives Division  
Power Apparatus & Components  
13131 West Little York Road | Houston, TX 77041  
Tel: 713-466-0277 | US: 800-231-1412 | CAN: 800-872-2192

**[www.toshiba.com/tic](http://www.toshiba.com/tic)**

Printed in USA