

CONTENTS

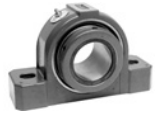

S-2000

Features / Benefits	B12-2
Specifications.....	B12-4
How to Order	B12-4
Nomenclature.....	B12-5
Selection	B12-7
Dimensions	
Pillow Block	B12-14
Flanges	B12-30
Piloted Flange.....	B12-38
Wide-Slot Take-Ups	B12-42
TP Take-Up.....	B12-46
Bearing Inserts	B12-48
End Cap	B12-50
Part Number Index.....	INDEX-1
Key Word Index	KEYWORD-1

Bearing Reference Guide

E-Family Roller Bearings

Specialty Tapered Products

S-2000

UNISPHERE II

IMPERIAL

UNIFIED SAF

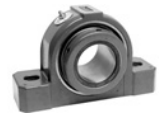

FEATURES/BENEFITS

S-2000

Longer Bearing Life By Design . . .

High capacity double row spherical rollers offer up to 250% more L₁₀ life than competitive brands

- Larger rollers
- More contact area
- Case-carburized inner rings resist cracking
- Static or dynamic misalignment up to $\pm 1^\circ$
- Expansion capability up to 3/8" (9.5mm)

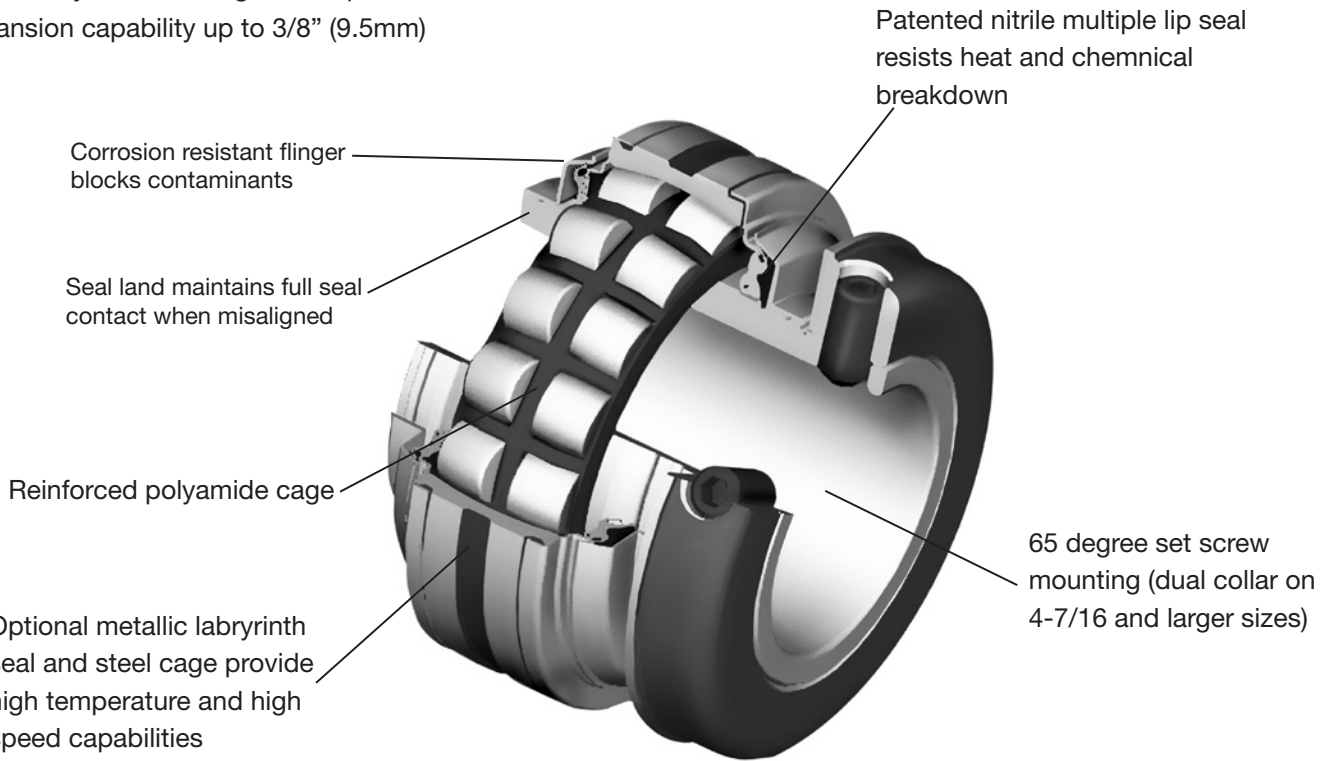

Installation Savings . . .

- Factory lubed, sealed and adjusted, ready to slip onto the shaft
- 65° Springlok collar mount for increased holding power versus 90° or 120°
- Field convertible from non-expansion to expansion and expansion to non-expansion
- Elongated pillow block bolt holes to facilitate mounting

Bearing Reference Guide

E-Family Roller Bearings

Specialty Tapered Products

S-2000

UNISPHERE II

IMPERIAL

UNIFIED SAF

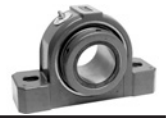

FEATURES/BENEFITS

S-2000

S-2000 Bearings Offer Patented Seal Options To Maximize Bearing Life . . .

TRIDENT™ Seals for low to medium speed

- Face rubbing triple lip seal
- Flinger to shield seal and bearing from contamination/damage
- Seal/land positive contact up to $\pm 1^\circ$ degree of misalignment
- Patented design

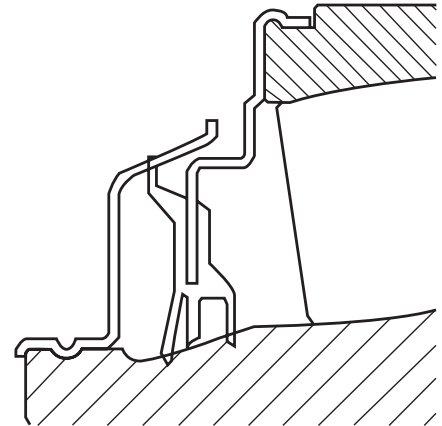

Labyrinth seals for higher speeds

- High speed for relatively clean environments
- Flinger shields seal and bearing from contamination/damage
- Seal operates with up to $\pm 1^\circ$ degree of misalignment
- Patented design

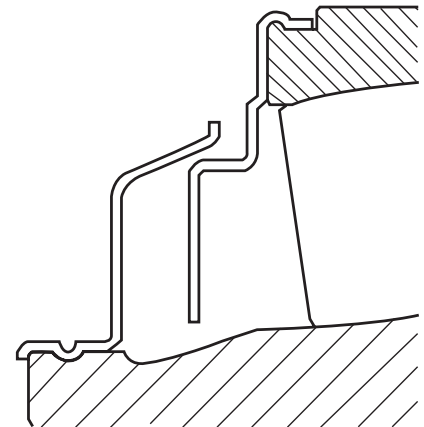

NOTE: Instruction manuals for Dodge bearings are available on www.dodge-pt.com



SPECIFICATION

S-2000

INCH

DODGE Spherical Bearings, including S-2000 bearings, are general purpose, high-capacity, double-row spherical roller bearings. All are mounted in single piece precision machined housings. Bearings are mounted to shafts by means of set screw collars, with 65 degree set screw spacing for maximum clamping force.

ASTM A48 Class 30 cast iron is the standard material used in S-2000 housings. A-27 Grade 70-36 Class 1 Steel is the standard material used in Steel S2000-HD

housings. Housing designs are available for survival in extreme harsh environments, through the use of special finishes and stainless hardware.

Housings are available in a variety of standard configurations, including pillow blocks, flanges, piloted flanges and take-up bearings. TRIDENT triple lip contact seal and Labyrinth seals are available on S-2000 bearings.



HOW TO ORDER

There are two ways to specify DODGE Bearings. Most of the product offerings have part numbers with listings shown throughout this catalog. Use of part numbers ensures accurate order processing.

When part numbers are not shown, the product may be specified by description or part name. This method is used when ordering units that include modifications or options. To order by description, use the nomenclature key shown on page B12-5 and add any special instructions to the end of the description for options not covered by the nomenclature.

DODGE Spherical Bearings are factory adjusted and pre-lubricated. For applications where extreme ambient temperatures, high speeds, or high loads are expected, a variety of specialty lubricants is available. Standard grease provided is lithium complex base Mobilgrease XHP222. High temperature

greases available include Mobil HTS #2. Other special lubricants are available upon request. Special lubricant options usually involve set-up charges, minimum quantities and list price premiums. To order, specify type of lubricant required at the end of the product name or after the standard part number.

Example: 070320 except with Mobil HTS #2 grease
or
P2BS2108L except with Mobil HTS #2 grease

For applications requiring modifications not listed, we encourage you to contact our Application Engineering Department for Bearings at 864-284-5700.

NOMENCLATURE

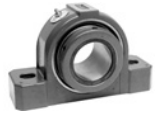

S-2000

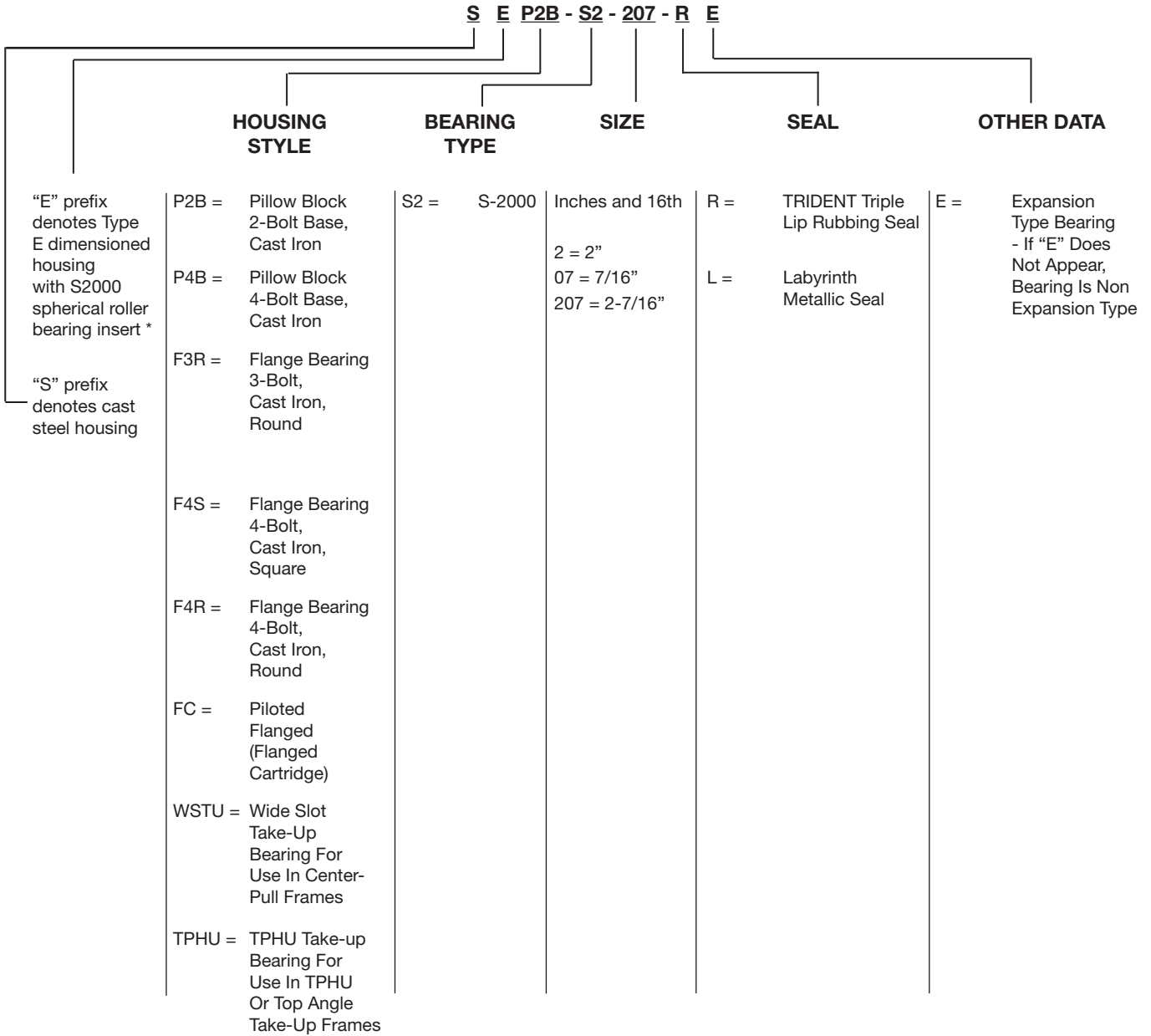

* Available in two or four bolt pillow blocks, four bolt square flanges and piloted flanges

FEATURES/BENEFITS PAGE B12-2	SPECIFICATION PAGE B12-4	SELECTION PAGE B12-7	DIMENSIONS PAGE B12-14
---------------------------------	-----------------------------	-------------------------	---------------------------

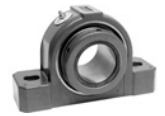

FEATURES/BENEFITS

Bearing Reference Guide

E-Family Roller Bearings

Specialty Tapered Products

S-2000

UNISPHERE II

IMPERIAL

UNIFIED SAF

S-2000-E

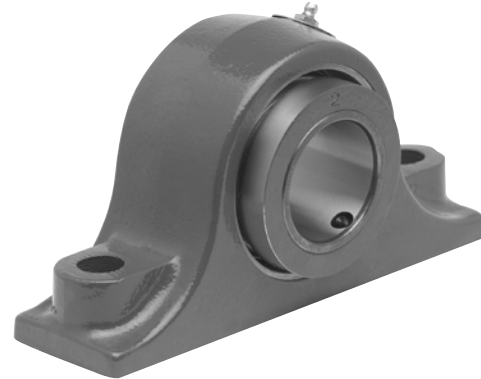

- Interchangeable with Type E style pillow blocks and flanges
- Same proven DODGE S-2000 double row spherical insert
- 65° springlock collar mounting
- Up to $\pm 1^\circ$ misalignment capability
- Seal land on OD of inner ring maintains full contact pressure even when misaligned
- High capacity double row spherical bearing
- 2-bolt pillow blocks in sizes 1-3/8 to 3-7/16"
- 4-bolt pillow blocks in sizes 2-7/16 to 4-15/16"
- Flange bearings in sizes 1-3/8 to 4-7/16"
- Piloted flange bearings in sizes 1-3/8 to 4-15/16"

S-2000-HD



Dodge S2000-HD mounted bearings feature proven S2000 technology deployed in steel housings designed specifically for harsh applications that demand superior housing strength. Major features include set screw mounting systems, high capacity cast steel housings with industry common dimensions, as well as high capacity, double row spherical inserts that are protected with either one of two effective sealing systems plus both closed & shaft-through end covers.

In addition, S2000-HD feature single piece, sealed inserts that can be easily replaced in the field, without the time & trouble of a bearing tear down & rebuild. Field conversion between Non-Expansion & Expansion (fixed & float) can also be accomplished with the repositioning of a single snap ring.

Housing configurations include two and four bolt base pillow blocks, and four bolt flanges.



SELECTION

S-2000 SPHERICAL ROLLER BEARINGS

DODGE Spherical Roller Bearings have the capacity to carry heavy radial loads and combined radial and thrust loads. The maximum recommended load which can be applied is limited by various components in the system such as bearing, housing, shaft, shaft attachment, speed and life requirements as listed in this catalog. DODGE spherical roller bearings have been applied successfully even when these limits have been exceeded under controlled operating conditions. Contact DODGE Application Engineering (864-284-5700) for applications which exceed the recommendations of this catalog.

L₁₀ Hours Life - The life which may be expected from at least 90% of a given group of bearings operating under identical conditions.

$$L_{10} \text{ Life, Hours} = \left(\frac{C}{P} \right)^{10/3} \times \left(\frac{16667}{\text{RPM}} \right)$$

Where: C = Dynamic Capacity
(Table 1 on page B12-9) lbs.

P = Equivalent Radial Load, lbs.

GENERAL

Heavy Service - For heavy shock loads, frequent shock loads, or severe vibrations, add up to 50% (according to severity of conditions) to the Equivalent Radial Load to obtain a Modified Equivalent Radial Load. Consult DODGE Application Engineering for additional selection assistance.

Thrust load values shown in the table below are recommended as a guide for general applications that will give adequate L₁₀ life. Spherical bearings require a radial load at least equal to the thrust load for proper operation. If the thrust load exceeds this limit, consult Application Engineering. Where substantial radial load is also present, it is advisable to calculate actual L₁₀ life to assure that it meets the requirements. The effectiveness of the shaft attachment to carry thrust load depends on proper tightening of the set screws, shaft tolerance and shaft deflections. Therefore, it is advisable to use auxiliary thrust carrying devices such as shaft shoulder, snap ring or a thrust collar to locate the bearing under thrust loads heavier than shown below, or where extreme reliability is desired.

RPM	20-200	201 - 2000	Over 2000
Recommended Thrust Load	C/20	C/40	C/60

The shaft tolerances recommended below are adequate for normal radial and radial/thrust load applications. The radial load is limited by the attachment to the shaft (see Table 1 on page B12-9). Where the applied radial load (F_R) exceeds this limit (maximum allowable slip fit radial load), a snug-to-light press fit of the shaft is required. Since the allowable load, especially at a

low speed, is very large, the shaft should be checked to assure adequate shaft strength.

The magnitude and direction of both the thrust and radial load must be taken into account when selecting a housing. **When pillow blocks are utilized, heavy loads should be directed through the base. Where uplift loads are involved, see Tables 6, 7 and 8 on pages B12-12 and B12-13 and for maximum values.** Where a load pulls the housing away from the mounting base, both the hold-down bolts and housing must be of adequate strength. Auxiliary load carrying devices such as shear bars are advisable for side or end loading of pillow blocks and radial loads for flange units.

Shaft Tolerances	
Shaft Size	S-2000
UP TO 1-1/2"	+.0000 -.0005"
1-9/16 TO 4"	+.000 -.001"
4-7/16 TO 5"	+.000 -.0015"

BEARING SUPPORTING RADIAL LOADS ONLY

1. Define L₁₀ Life Hours desired.

2. Establish bearing radial load, F_R

(F_R = P for Pure Radial Load Conditions). The DODGE program BEST™* can be used to find application loads.

3. Establish RPM.

Using the easy selection Table 4 on page B12-10, find, under the RPM column, the equivalent radial load that equals or is slightly higher than the application radial load for the desired life. The shaft size on the far left will be the minimum shaft size that you can use for your application.

If the desired life is different than the values shown on the chart, use alternate Method A shown below.

Example: 1. L₁₀ Life = 30,000 Hours
2. Radial load = 4000 lbs.
3. RPM = 1,020

At the intersection of the 1,020 RPM column and the 30,000 hours L₁₀ life row, the equivalent radial load of 4092 lbs. exceeds the 4000 lbs. radial load for shaft size 2-7/16". A bearing with bore 2-7/16", or larger, may be used for this application.

* The DODGE Bearing Evaluation and Selection Technique (BEST) is a menu driven computer program that calculates bearing loads, fatigue life and operating temperature for a two bearing shaft system based on user supplied input parameters. This interactive program is available at www.ptwizard.com under the Product Selection area.

FEATURES/BENEFITS PAGE B12-2	SPECIFICATION PAGE B12-4	HOW TO ORDER/NOMENCLATURE PAGE B12-5	DIMENSIONS PAGE B12-14
---------------------------------	-----------------------------	---	---------------------------

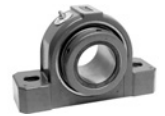

SELECTION

Bearing Reference Guide

E-Family Roller Bearings

Specialty Tapered Products

S-2000

UNISPHERE II

IMPERIAL

UNIFIED SAF

ALTERNATE METHOD A - SELECTING A BEARING FOR AN L₁₀ LIFE VALUE NOT SHOWN IN THE EASY SELECTION CHART.

The L₁₀ life equation can be rearranged so that the bearing dynamic capacity **C** is identified in terms of L₁₀, RPM and P

$$C = \left(\frac{L_{10} \times \text{RPM}}{16667} \right)^{0.3} \times P$$

(P = F_R for Pure Radial Load Conditions)

Since the L₁₀, RPM and P are known, solve for C. Select from the dynamic capacity column on Table 1 on page B12-9 the **C** value equal to or greater than the **C** value just calculated. The bore size on the far left represents the proper bore size selection. Check that the application RPM does not exceed the MAX. RPM on Table 1. Also check that the radial load does not exceed the Maximum Allowable Slip Fit Radial Load shown on Table 1 on page B12-9. If it does, a line-to-line to light press fit of shaft is required. When selecting an L₁₀ life of less than 30,000 hours, particular attention must be paid to shaft deflection and proper lubricant selection.

SELECTING BEARINGS SUPPORTING COMBINATION RADIAL AND THRUST LOADS

When a bearing supports both a radial load and a thrust load, the loading on the two rows is shared unequally depending on the ratio of thrust to radial load. The use of the X (radial factor) and Y (thrust factor) from Table 1 converts the applied thrust load and radial loads to an equivalent radial load having the same effect on the life of the bearing as a radial load of this magnitude.

The equivalent radial load $P = XF_R + YF_A$

Where:

P = Equivalent radial load, lbs.

F_R = Radial load, lbs. (see Table 1 for allowable slip fit maximum load)

F_A = Thrust (axial) load, lbs.

e = Thrust load to radial load factor (Table 1)

X = Radial load factor (Table 1)

Y = Thrust load factor (Table 1)

To find X and Y, calculate F_A/F_R and compare to **e** for the selected bore size. Determine X and Y from Table 1 on page B12-9 depending on whether F_A/F_R is equal to or less than **e**,

or F_A/F_R is greater than **e**. Substitute all known values into the equivalent radial load equation. P (equivalent radial load) can be used in the life formula to determine L₁₀, or it can be compared to the allowable equivalent radial load ratings for the speed and hours life desired in the easy selection Table 4 on page B12-10.

SELECTING BEARINGS SUPPORTING ONLY THRUST LOADS

Spherical Roller Bearings generally are not recommended for pure thrust load applications. However, they will perform satisfactorily under very light pure thrust loads. Consult DODGE Application Engineering (864-284-5700).

SELECTING LUBRICATION

DODGE S2000 spherical roller bearings are lubricated at the factory with Mobilgrease XHP 222 grease. Mobilgrease XHP 222 grease is a superior industrial grease using a lithium complex thickener and highly refined base oil. This grease will adequately handle low and medium speeds with low and medium loads at normal temperatures as defined on Table 5 on page B12-11. For very low and high speeds, for heavy loads and for low and high temperatures, special greases must be used. Contact DODGE Application Engineering (864-284-5700). DODGE engineers will recommend bearings and lubricants for the above unusual conditions. DODGE also has the expertise to custom design and build special bearings for your needs. The only maintenance requirement for DODGE Unitized roller bearings is periodic relubrication at regular intervals as outlined in the appropriate instruction manuals.

MISALIGNMENT CONSIDERATIONS

In nearly all applications, good design practice requires two bearings supporting the shaft. In cases where three or more bearings are installed, unless precautions are taken to line the bearings up both vertically and horizontally, it is possible to induce heavy loads. In the case of two bearings, alignment is not as critical, especially with DODGE Unitized Spherical Roller Bearings. S2000 bearings are designed to allow a maximum of ±1° of static and dynamic misalignment. To ensure good alignment, mounting surfaces must be checked for flatness and must lie in the same plane. When tightening base bolts, each bolt should be alternately tightened in incremental torque values until full torque is achieved to prevent the angular shifting of the pillow block that occurs when one bolt is tightened to its full torque. Shimming may be required to minimize misalignment.

FEATURES/BENEFITS PAGE B12-2	SPECIFICATION PAGE B12-4	HOW TO ORDER/NOMENCLATURE PAGE B12-5	DIMENSIONS PAGE B12-14
---------------------------------	-----------------------------	---	---------------------------



SELECTION

S-2000

Bearing Reference Guide

E-Family Roller Bearings

Specialty Tapered Products

S-2000

UNISPHERE II

IMPERIAL

UNIFIED SAF

Table 1: S2000-HD Spherical Roller Bearings

Shaft Size Inches	Basic Bearing Description	e	F _A /F _R < e		F _A /F _R > e		Max. Allowable Slip Fit Radial Load F _R * lbs.	Dynamic Capacity (C) lbs.	Static Capacity Co lbs.	Maximum Speed **	
			X	Y	X	Y				Labyrinth RPM	TRIDENT Triple Lip RPM
1-3/8 1-7/16 1-1/2	22208	0.28	1.0	2.4	0.67	3.6	3,750	20,800	21,000	3,600	2,900
1-11/16 1-3/4	22209	0.26	1.0	2.6	0.67	3.9	3,750	20,800	22,000	3,360	2,460
1-15/16 2	22210	0.24	1.0	2.8	0.67	4.2	4,000	22,000	24,000	3,180	2,200
2-3/16	22211	0.23	1.0	2.9	0.67	4.3	4,860	27,000	29,000	2,700	1,950
2-7/16	22213	0.24	1.0	2.8	0.67	4.2	6,840	39,000	47,500	2,250	1,740
2-11/16 2-15/16 3	22215	0.22	1.0	3.1	0.67	4.6	7,500	41,500	53,000	2,040	1,490
3-7/16	22218	0.23	1.0	2.9	0.67	4.3	11,500	65,500	81,500	1,560	1,280
3-15/16	22220	0.24	1.0	2.8	0.67	4.2	14,400	83,000	104,000	1,320	1,075
4-7/16	22222	0.25	1.0	2.7	0.67	4.1	18,400	104,000	132,000	1,200	990
4-15/16	22226	0.26	1.0	2.6	0.67	3.9	25,700	146,000	196,000	1,020	870

* If load exceeds the maximum allowable slip fit load, line- to-line to light press fit of shaft required. Maximum slip fit radial loads apply if recommended shaft sizes are used.

** Maximum speed is dependent on load and ambient conditions, consult DODGE Engineering.

After final alignment of the shaft and installation of the housings, tighten both setscrews hand tight, then the setscrews should be tightened alternately and in small increments to the torque specified in Table 2. After 24 hours operation, the setscrews should be retightened to the torque in Table 2 to assure full locking of the inner race to the shaft. Care should be taken that the socket key or driver is in good condition with no rounded corners and the key is fully engaged in the setscrew and held square with the setscrew to prevent rounding out of the setscrew socket when applying maximum torque.

Table 2: Set Screw Torque Values

Set Screw Torque Table		
Shaft Size	Socket Set Screw Size	Tightening Torque
1-3/8 - 1-3/4 in.	5/16 in.	165 Inch Pounds
1-15/16 - 2-7/16 in.	3/8 in.	290 Inch Pounds
2-11/16 - 3-7/16 in.	1/2 in.	620 Inch Pounds
3-15/16 - 4-15/16 in.	5/8 in.	1325 Inch Pounds

Table 3: Lubrication Intervals

Lubrication Guide (In Weeks)								
Read Preceding Paragraphs Before Establishing Lubrication Schedule								
Hours Run per Day	1 to 250 RPM	251 to 500 RPM	501 to 750 RPM	751 to 1000 RPM	1001 to 1500 RPM	1501 to 2000 RPM	2001 to 2500 RPM	2501 to 3000 RPM
8	12	12	10	7	5	4	3	2
16	12	7	5	4	2	2	2	1
24	10	5	3	2	1	1	1	1



SELECTION

S-2000

Table 4: Easy Selection Table for S-2000 Double Row Spherical Roller Bearings

Shaft Size Inches	L ₁₀ Life Hours	Allowable Equivalent Radial Load Rating (lbs.) at Various Revolutions per Minute																
		50	100	150	250	500	870	1,020	1,200	1,320	1,560	1,750	2,040	2,250	2,700	3180	3360	3600
1-3/8 to 1-1/2	10,000	7,498	6,090	5,393	4,626	3,758	3,182	3,034	2,890	2,808	2,671	2,581	2,465	2,393	1,495	2,157	2,122	2,078
	30,000	5,393	4,380	3,878	3,327	2,703	2,289	2,182	2,078	2,020	1,921	1,856	1,773	1,721	1,495	1,552	1,526	1,495
	40,000	4,947	4,018	3,558	3,052	2,479	2,100	2,002	1,907	1,853	1,762	1,703	1,626	1,579	1,495	1,423	1,400	1,371
	60,000	4,380	3,558	3,150	2,703	2,195	1,859	1,773	1,688	1,641	1,560	1,508	1,440	1,398	1,324	1,260	1,240	1,214
1-11/16 to 1-3/4	10,000	7,498	6,090	5,393	4,626	3,758	3,182	3,034	2,890	2,808	2,671	2,581	2,465	1,579	2,266	2,157	2,122	
	30,000	5,393	4,380	3,878	3,327	2,703	2,289	2,182	2,078	2,020	1,921	1,856	1,773	1,579	1,630	1,552	1,526	
	40,000	4,947	4,018	3,558	3,052	2,479	2,100	2,002	1,907	1,853	1,762	1,703	1,626	1,579	1,495	1,423	1,400	
	60,000	4,380	3,558	3,150	2,703	2,195	1,859	1,773	1,688	1,641	1,560	1,508	1,440	1,398	1,324	1,260	1,240	
1-15/16 to 2	10,000	7,930	6,441	5,704	4,893	3,975	3,366	3,209	3,057	2,970	2,825	2,729	1,720	2,531	2,396	2,282		
	30,000	5,704	4,633	4,102	3,519	2,859	2,421	2,308	2,198	2,136	2,032	1,963	1,720	1,820	1,724	1,641		
	40,000	5,232	4,250	3,763	3,228	2,622	2,221	2,117	2,017	1,960	1,864	1,801	1,720	1,670	1,581	1,505		
	60,000	4,633	3,763	3,332	2,859	2,322	1,966	1,875	1,786	1,735	1,650	1,594	1,523	1,479	1,400	1,333		
2-3/16	10,000	9,733	7,905	7,000	6,005	4,878	4,131	3,939	3,751	3,645	3,467	2,210	3,199	3,106	2,941			
	30,000	7,000	5,686	5,035	4,319	3,508	2,971	2,833	2,698	2,622	2,494	2,210	2,301	2,234	2,115			
	40,000	6,421	5,216	4,618	3,962	3,218	2,726	2,599	2,475	2,405	2,288	2,210	2,111	2,050	1,940			
	60,000	5,686	4,618	4,089	3,508	2,850	2,413	2,301	2,191	2,130	2,026	1,957	1,869	1,815	1,718			
2-7/16	10,000	14,058	11,419	10,111	8,674	7,046	5,967	5,689	5,418	5,266	5,008	4,838	4,621	4,487				
	30,000	10,111	8,213	7,272	6,239	5,068	4,292	4,092	3,897	3,787	3,602	3,480	3,324	3,227				
	40,000	9,275	7,534	6,671	5,723	4,649	3,937	3,753	3,575	3,474	3,304	3,192	3,049	2,960				
	60,000	8,213	6,671	5,907	5,068	4,116	3,486	3,324	3,165	3,076	2,926	2,827	2,700	2,621				
2-11/16 to 3	10,000	14,959	12,151	10,759	9,230	7,497	6,350	6,054	5,766	5,666	5,329	5,149	4,917					
	30,000	10,759	8,739	7,738	6,639	5,392	4,567	4,354	4,147	3,697	3,833	3,703	3,537					
	40,000	9,870	8,017	7,098	6,090	4,946	4,189	3,994	3,804	3,697	3,516	3,397	3,244					
	60,000	8,739	7,098	6,285	5,392	4,380	3,709	3,537	3,368	3,273	3,113	3,008	2,873					
3-7/16	10,000	23,611	19,178	16,981	14,569	11,833	10,022	9,555	9,004	8,844	8,411							
	30,000	16,981	13,793	12,213	10,478	8,511	7,208	6,872	6,004	6,360	6,050							
	40,000	15,577	12,653	11,203	9,612	7,807	6,612	6,304	6,004	5,835	5,549							
	60,000	13,793	11,203	9,920	8,511	6,913	5,855	5,582	5,316	5,166	4,914							
100,000	11,833	9,612	8,511	7,302	5,931	5,023	4,789	4,561	4,432	4,216								

Only the labyrinth seal (L seal) may be used to the right of the heavy line.

In the light shaded area, a line-to-line to light press fit on the shaft is required.

For applications in the dark shaded area, the maximum load for the specific speed is shown. The load does not correspond to the 10 shown at the left.

FEATURES/BENEFITS PAGE B12-2	SPECIFICATION PAGE B12-4	HOW TO ORDER/NOMENCLATURE PAGE B12-5	DIMENSIONS PAGE B12-14
---------------------------------	-----------------------------	---	---------------------------

SELECTION

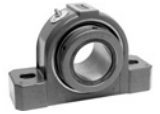

S-2000

Table 4: Easy Selection Table for S-2000 Double Row Spherical Roller Bearings (continued)

Shaft Size Inches	L ₁₀ Life Hours	Allowable Equivalent Radial Load Rating (Lbs.) At Various Revolutions Per Minute																		
		50	100	150	250	500	870	1,020	1,200	1,320	1,560	1,750	2,040	2,250	2,700	3180	3360	3600		
3-15/16	10,000	29,919	24,302	21,518	18,461	14,995	12,699	7,988	11,531	11,206										
	30,000	21,518	17,478	15,476	13,278	10,785	9,134	7,988	8,294	8,060										
	40,000	19,739	16,033	14,197	12,180	9,893	8,378	7,988	7,608	7,393										
	60,000	17,478	14,197	12,571	10,785	8,760	7,419	7,073	6,737	6,547										
	100,000	14,995	12,180	10,785	9,252	7,515	6,365	6,068	5,779	5,616										
4-7/16	10,000	37,489	30,450	26,963	23,132	18,789	10,498	15,171	14,449											
	30,000	26,963	21,901	19,392	16,637	13,513	10,498	10,911	10,392											
	40,000	24,733	20,090	17,789	15,261	12,396	10,498	10,009	9,533											
	60,000	21,901	17,789	15,751	13,513	10,976	9,296	8,863	8,441											
	100,000	18,789	15,261	13,513	11,593	9,417	7,975	7,603	7,242											
4-15/16	10,000	52,628	42,747	37,851	32,473	26,377	14,738	21,298												
	30,000	37,851	30,745	27,224	23,356	18,971	14,738	15,318												
	40,000	34,722	28,203	24,973	21,424	17,402	14,738	14,051												
	60,000	30,745	24,973	22,112	18,971	15,409	13,050	12,442												
	100,000	26,377	21,424	18,971	16,275	13,220	11,196	10,674												

Only the labyrinth seal (L seal) may be used to the right of the heavy line.

In the light shaded area, a line-to-line to light press fit on the shaft is required.

For applications in the dark shaded area, the maximum load for the specific speed is shown. The load does not correspond to the L₁₀ shown at the left.

Table 5: Definition Of Operating Conditions For Unitized Spherical Roller Bearings

LOW SPEED	UP TO 20% OF MAX. RPM (TABLE 1)
MEDIUM SPEED	OVER 20% TO 80% OF MAX. RPM
HIGH SPEED	MOVER 80% OF MAX. RPM
LIGHT LOAD	UP TO 8% OF C (TABLE 1)
NORMAL LOAD	OVER 8% TO 18% OF C
HEAVY LOAD	OVER 18% OF C
	C = DYNAMIC CAPACITY
LOW TEMPERATURE	-20 TO -100°F
MEDIUM TEMPERATURE	OVER 20°F TO 200°F
HIGH TEMPERATURE	OVER 200°F TO 250°F

FEATURES/BENEFITS PAGE B12-2	SPECIFICATION PAGE B12-4	HOW TO ORDER/NOMENCLATURE PAGE B12-5	DIMENSIONS PAGE B12-14
---------------------------------	-----------------------------	---	---------------------------

Bearing Reference Guide
E-Family Roller Bearings
Specialty Tapered Products
S-2000
UNISPHERE II
IMPERIAL
UNIFIED SAF



SELECTION

S-2000

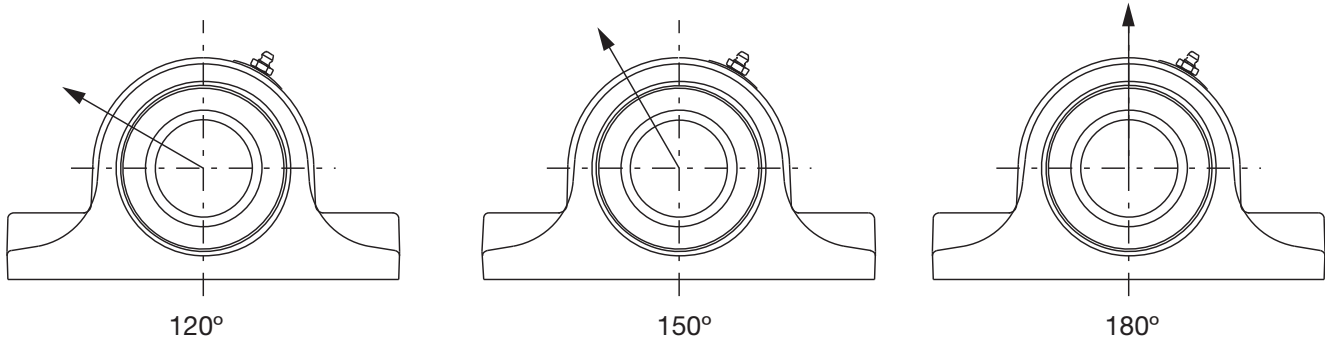

Table 6: S-2000 Housing Rating, 2-Bolt, Cast Iron*

Bore Size	Maximum Recommended Housing Cap Loads, lb		
	120°	150°	180°
1-3/8 to 1-1/2	2110	2640	3100
1-5/8 to 1-3/4	2380	2980	3500
1-15/16 to 2	3130	3910	4600
2-3/16	3330	4160	4900
2-7/16	3330	4160	4900
2-11/16 to 3	4420	5520	6500
3-3/16 to 3-7/16	4620	5780	6800
3-15/16	7500	9350	11000

Table 7: S-2000 Housing Rating, 4-Bolt, Cast Iron*

Bore Size	Maximum Recommended Housing Cap Loads, lb		
	120°	150°	180°
1-15/16 - 2	3200	4000	4700
2-3/16	3300	4100	4800
2-7/16	3810	4760	5600
2-11/16 to 3	4620	5780	6800
3-7/16	4700	5870	6900
3-15/16	7500	9350	11000
4-7/16	9900	12330	14500
4-15/16	13400	16750	19700

- * When utilizing heavy cap loads on pillow block housings, the installation must adhere to the following procedures:
1. The pillow block base bolts must be of high strength (Grade 8) bolts and properly tightened to mounting structure.
 2. Stop bars (shear strips) should be used against the plummer block where side loads are encountered.
 3. In all cases where loads are heavy, the L₁₀ life of the bearing should be checked for proper selection and life requirements.

FEATURES/BENEFITS PAGE B12-2	SPECIFICATION PAGE B12-4	HOW TO ORDER/NOMENCLATURE PAGE B12-5	DIMENSIONS PAGE B12-14
---------------------------------	-----------------------------	---	---------------------------

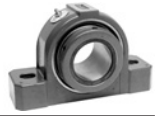

S2000-HD

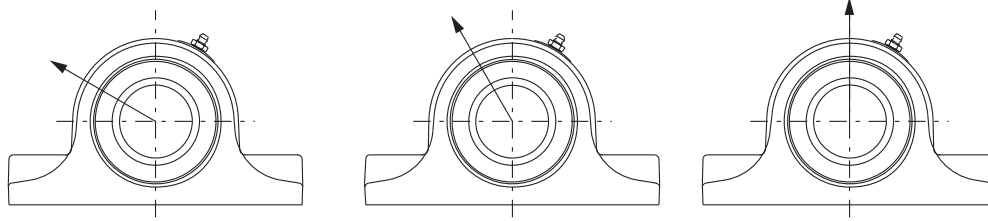

Table 8: Steel Housed S2000 - Housing Ratings*

Shaft Sizes	Basic Bearing Description	Maximum Recommended Housing Loads, lb	
		P2B	P4B
1-3/8 1-7/16 1-1/2	22208	24400	
1-11/16 1-3/4	22209	26400	
1-15/16 2	22210	30200	
2-3/16 2-7/16	22211 22213	35400 51300	52800
2-11/16 2-15/16 3	22215	59700	60000
3-7/16 3-15/16	22218 22220	90700	115000
4-7/16 4-15/16	22222 22226		152100 188200

* It is important to note that the values listed above are housing fracture loads from various applied directions. These loads may exceed bearing, mounting bolt and/or shaft capacities. Applications subject to heavy housing loads, particularly shock loads, must adhere to the following procedures:

- (1) The pillow block base bolts must be of high strength (Grade 8) bolts and properly tightened to mounting structure.
- (2) Stop bars (shear strips) should be used against the plummer block where side loads are encountered.
- (3) In all cases where loads are heavy, the L₁₀ life of the bearing should be checked for proper selection and life requirements.

FEATURES/BENEFITS PAGE B12-2	SPECIFICATION PAGE B12-4	HOW TO ORDER/NOMENCLATURE PAGE B12-5	DIMENSIONS PAGE B12-14
---------------------------------	-----------------------------	---	---------------------------

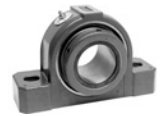

DIMENSIONS

**S-2000 Pillow Block
2-BOLT BASE - INCH**

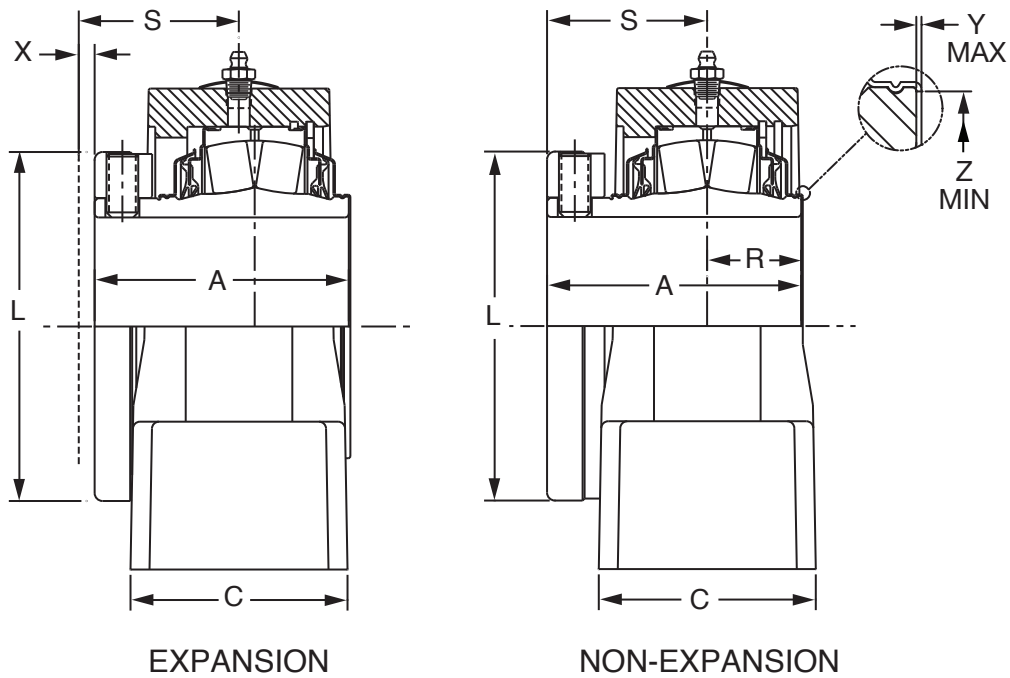
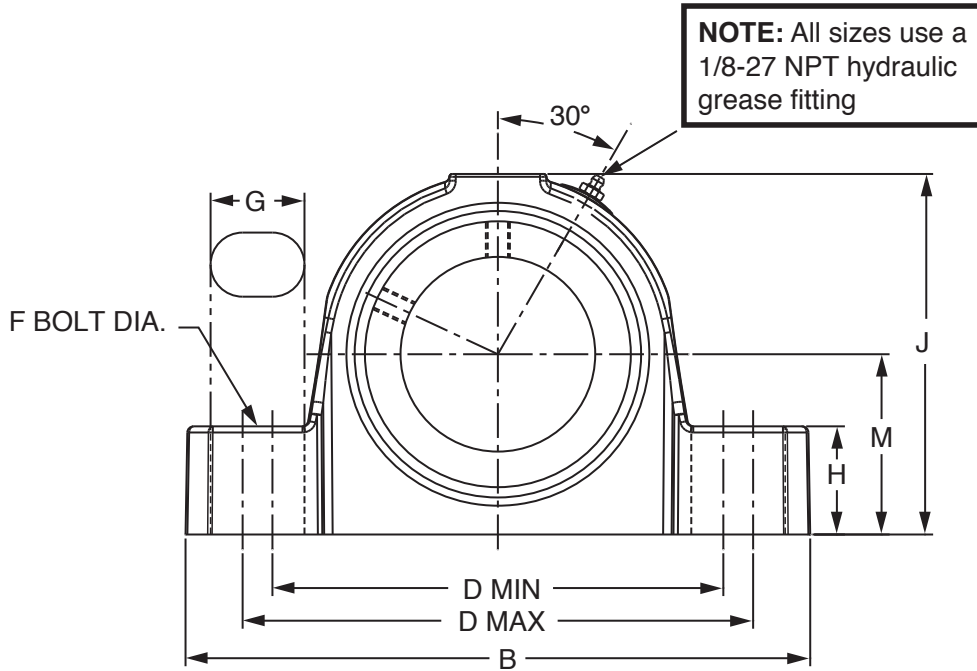



DIMENSIONS

S-2000 Pillow Block 2-BOLT BASE - INCH

Bearing Reference Guide

E-Family Roller Bearings

Specialty Tapered Products

S-2000

UNISPHERE II

IMPERIAL

UNIFIED SAF

Bearing	Shaft Size Inch	TRIDENT Seal				Labyrinth Seal			
		Non-Expansion		Expansion		Non-Expansion		Expansion	
		Part No.	Part Name	Part No.	Part Name	Part No.	Part Name	Part No.	Part Name
22208	1-3/8	070272	P2B-S2-106R	070295	P2B-S2-106RE	070318	P2B-S2-106L	070341	P2B-S2-106LE
	1-7/16	070273	P2B-S2-107R	070296	P2B-S2-107RE	070319	P2B-S2-107L	070342	P2B-S2-107LE
	1-1/2	070274	P2B-S2-108R	070297	P2B-S2-108RE	070320	P2B-S2-108L	070343	P2B-S2-108LE
22209	1-11/16	070276	P2B-S2-111R	070299	P2B-S2-111RE	070322	P2B-S2-111L	070345	P2B-S2-111LE
	1-3/4	070277	P2B-S2-112R	070300	P2B-S2-112RE	070323	P2B-S2-112L	070346	P2B-S2-112LE
22210	1-15/16	070278	P2B-S2-115R	070301	P2B-S2-115RE	070324	P2B-S2-115L	070347	P2B-S2-115LE
	2	070279	P2B-S2-200R	070302	P2B-S2-200RE	070325	P2B-S2-200L	070348	P2B-S2-200LE
22211	2-3/16	070280	P2B-S2-203R	070303	P2B-S2-203RE	070326	P2B-S2-203L	070349	P2B-S2-203LE
22213	2-7/16	070282	P2B-S2-207R	070305	P2B-S2-207RE	070328	P2B-S2-207L	070351	P2B-S2-207LE
22215	2-11/16	070284	P2B-S2-211R	070307	P2B-S2-211RE	070330	P2B-S2-211L	070353	P2B-S2-211LE
	2-15/16	070285	P2B-S2-215R	070308	P2B-S2-215RE	070331	P2B-S2-215L	070354	P2B-S2-215LE
	3	070286	P2B-S2-300R	070309	P2B-S2-300RE	070332	P2B-S2-300L	070355	P2B-S2-300LE
22218	3-7/16	070288	P2B-S2-307R	070311	P2B-S2-307RE	070334	P2B-S2-307L	070357	P2B-S2-307LE
22220	3-15/16	070290	P2B-S2-315R	070313	P2B-S2-315RE	070336	P2B-S2-315L	070359	P2B-S2-315LE

Shaft Size	A	B	C	D		F Bolt Dia.	G	H	J	L	M	R	S	X Total Exp.	Y	Z
				Min	Max											
1-3/8																
1-7/16	2.53	6.88	1.95	4.81	5.20	1/2	0.81	1.13	3.88	2.75	1.88	0.88	1.66	3/16	0.020	1.80
1-1/2																
1-11/16																
1-3/4	2.67	7.38	2.06	5.31	5.70	1/2	0.81	1.25	4.27	3.19	2.13	0.81	1.86	1/4	0.020	2.08
1-15/16																
2	2.84	8.38	2.50	6.06	6.44	5/8	0.95	1.31	4.56	3.44	2.25	0.86	1.98	1/4	0.020	2.30
2-3/16	2.94	8.88	2.63	6.56	6.94	5/8	0.95	1.50	5.00	3.75	2.50	0.91	2.03	1/4	0.025	2.60
2-7/16	3.20	9.25	2.81	6.94	7.31	5/8	0.95	1.63	5.59	4.06	2.75	1.13	2.08	1/4	0.025	2.95
2-11/16																
2-15/16	3.59	10.44	3.08	7.94	8.31	3/4	1.06	1.88	6.38	4.70	3.25	1.14	2.45	1/4	0.025	3.47
3																
3-7/16	4.02	13.00	3.42	9.38	10.63	7/8	1.63	2.25	7.50	5.50	3.75	1.41	2.61	1/4	0.025	4.05
3-15/16	4.47	15.25	3.94	10.63	12.88	1	2.25	2.44	8.38	6.00	4.25	1.56	2.91	5/16	0.025	4.50

FEATURES/BENEFITS PAGE B12-2	SPECIFICATION PAGE B12-4	HOW TO ORDER/NOMENCLATURE PAGE B12-4	SELECTIONS PAGE B12-7
---------------------------------	-----------------------------	---	--------------------------



DIMENSIONS

S-2000 Pillow Block with Type E Dimensions 2-BOLT

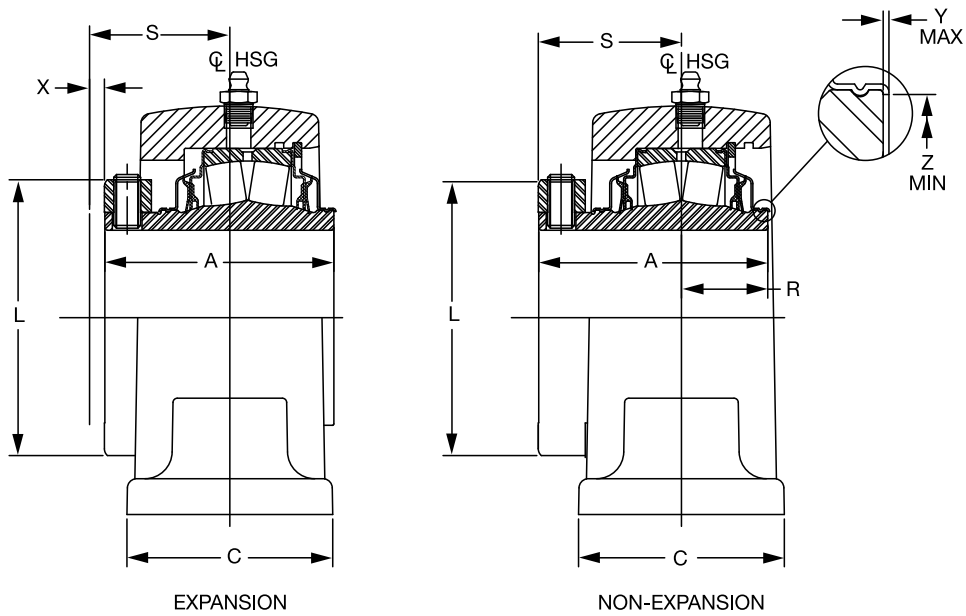
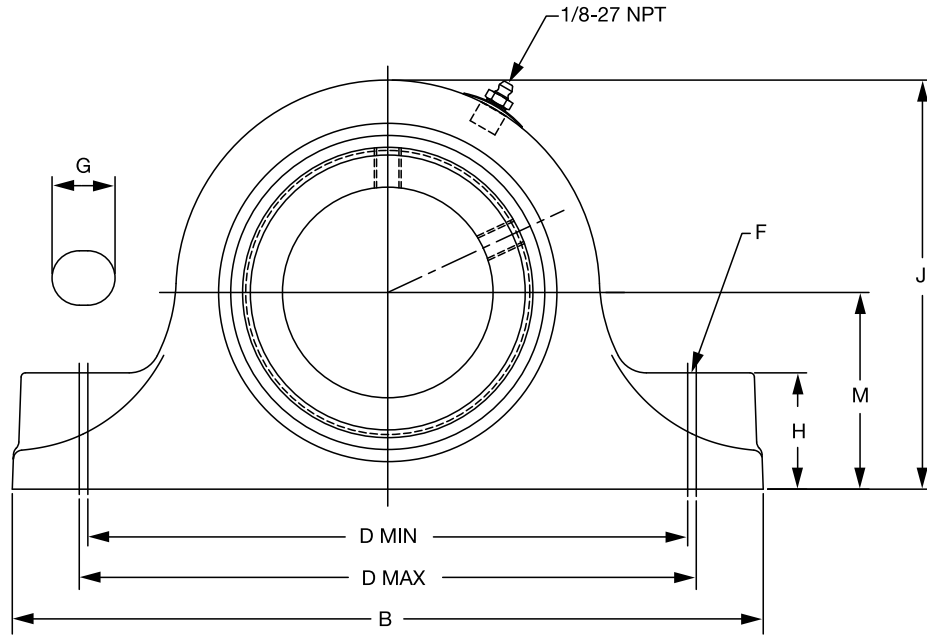

DIMENSIONS

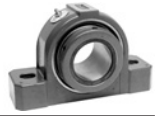

S-2000 Pillow Block with Type E Dimensions 2-BOLT

Bearing Reference Guide

E-Family Roller Bearings

Specialty Tapered Products

S-2000

UNISPHERE II

IMPERIAL

UNIFIED SAF

Bearing Series	Shaft Size*	TRIDENT Seal				Labyrinth Seal			
		Non Expansion		Expansion		Non Expansion		Expansion	
		Part No.	Part Name	Part No.	Part Name	Part No.	Part Name	Part No.	Part Name
22208	1-3/8	071389	EP2B-S2-106R	071400	EP2B-S2-106RE	071411	EP2B-S2-106L	071422	EP2B-S2-106LE
	1-7/16	071390	EP2B-S2-107R	071401	EP2B-S2-107RE	071412	EP2B-S2-107L	071423	EP2B-S2-107LE
22209	1-11/16	071391	EP2B-S2-111R	071402	EP2B-S2-111RE	071413	EP2B-S2-111L	071424	EP2B-S2-111LE
22210	1-15/16	071392	EP2B-S2-115R	071403	EP2B-S2-115RE	071414	EP2B-S2-115L	071425	EP2B-S2-115LE
	2	071393	EP2B-S2-200R	071404	EP2B-S2-200RE	071415	EP2B-S2-200L	071426	EP2B-S2-200LE
22211	2-3/16	071394	EP2B-S2-203R	071405	EP2B-S2-203RE	071416	EP2B-S2-203L	071427	EP2B-S2-203LE
22213	2-7/16	071395	EP2B-S2-207R	071406	EP2B-S2-207RE	071417	EP2B-S2-207L	071428	EP2B-S2-207LE
22215	2-11/16	071396	EP2B-S2-211R	071407	EP2B-S2-211RE	071418	EP2B-S2-211L	071429	EP2B-S2-211LE
	2-15/16	071397	EP2B-S2-215R	071408	EP2B-S2-215RE	071419	EP2B-S2-215L	071430	EP2B-S2-215LE
	3	071398	EP2B-S2-300R	071409	EP2B-S2-300RE	071420	EP2B-S2-300L	071431	EP2B-S2-300LE
22218	3-7/16	071399	EP2B-S2-307R	071410	EP2B-S2-307RE	071421	EP2B-S2-307L	071432	EP2B-S2-307LE

*Consult Dodge For Sizes Not Listed

Shaft Size	A	B#	C#	D		F Bolt Dia.	G#	H#	J#	L	M	R	S	X Total Exp.	Y	Z	Set Screw Size	S/S Torque In/Lbs
				Min	Max													
1-3/8 1-7/16	2.53	7.37	2.12	5.63	5.88	1/2	0.75	1.13	3.85	2.55	1.88	1.03	1.50	5/32	0.020	1.80	5/16-18	165
1-11/16	2.67	7.88	2.38	6.13	6.38	1/2	0.75	1.25	4.25	3.01	2.13	0.98	1.69	3/16	0.020	2.08	5/16-18	165
1-15/16 2	2.84	8.87	2.49	6.88	7.12	5/8	0.88	1.31	4.47	3.44	2.25	1.08	1.76	7/32	0.020	2.30	3/8-16	290
2-3/16	2.94	9.62	2.56	7.63	7.88	5/8	0.88	1.50	5.00	3.50	2.50	1.06	1.88	1/4	0.025	2.60	3/8-16	290
2-7/16	3.20	10.50	2.87	8.38	8.62	5/8	0.88	1.63	5.71	4.06	2.75	1.20	2.00	1/4	0.025	2.95	3/8-16	290
2-11/16	3.59	12.00	2.99	9.31	9.69	3/4	1.07	1.88	6.32	4.61	3.13	1.34	2.25	1/4	0.025	3.47	1/2-13	620
2-15/16 3																		
3-7/16	4.01	14.00	3.49	10.81	11.19	7/8	1.19	2.25	7.69	5.50	3.75	1.51	2.50	1/4	0.025	4.05	1/2-13	620

Notes: "A" And "R" Dimensions Do Not Include "Y" Dimension

Reference Dimension Only

FEATURES/BENEFITS PAGE B12-2	SPECIFICATION PAGE B12-4	HOW TO ORDER/NOMENCLATURE PAGE B12-4	SELECTIONS PAGE B12-7
---------------------------------	-----------------------------	---	--------------------------



DIMENSIONS

Steel S-2000-HD Pillow Block 2-Bolt

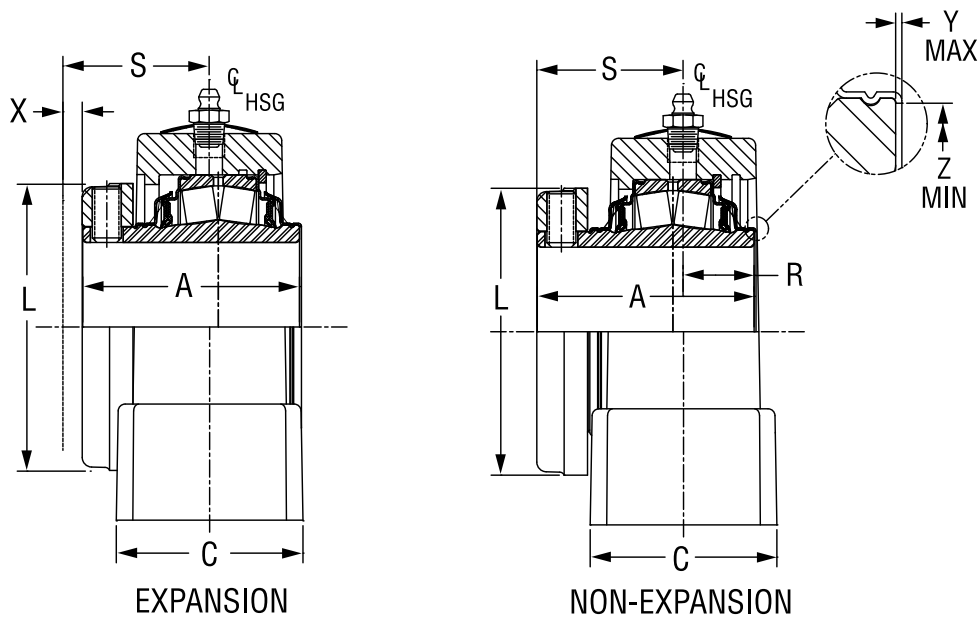
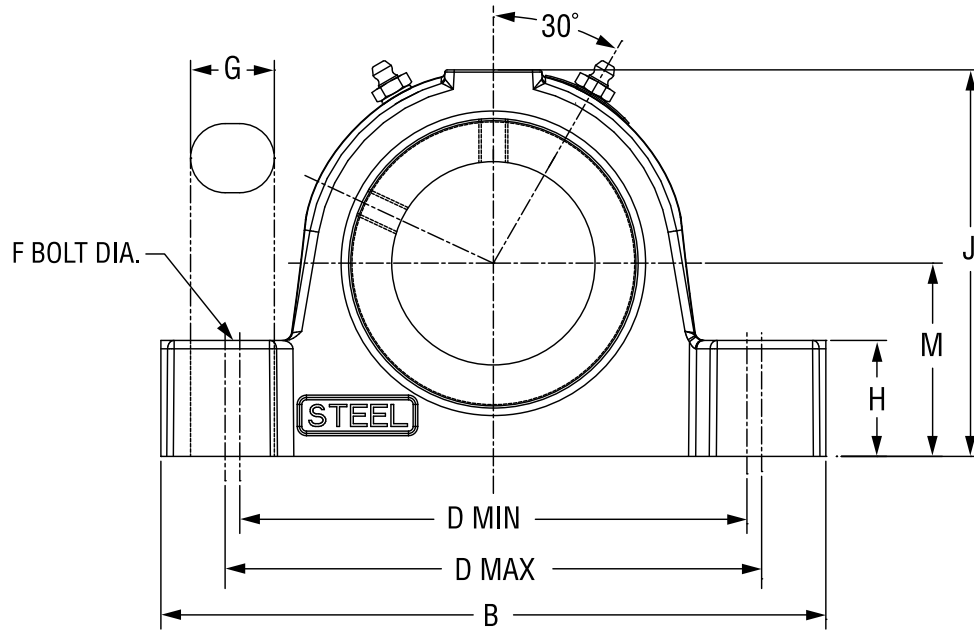



SELECTION

Steel S-2000-HD Pillow Block 2-Bolt

Bearing Reference Guide

E-Family Roller Bearings

Specialty Tapered Products

S-2000

UNISPHERE II

IMPERIAL

UNIFIED SAF

Shaft Size	Dodge Non-Expansion		Dodge Expansion	
	Part No.	Description	Part No.	Description
1-3/8	071790	SP2B-S2-106R	071804	SP2B-S2-106RE
1-7/16	071791	SP2B-S2-107R	071805	SP2B-S2-107RE
1-1/2	071792	SP2B-S2-108R	071806	SP2B-S2-108RE
1-11/16	071793	SP2B-S2-111R	071807	SP2B-S2-111RE
1-3/4	071794	SP2B-S2-112R	071808	SP2B-S2-112RE
1-15/16	071795	SP2B-S2-115R	071809	SP2B-S2-115RE
2	071796	SP2B-S2-200R	071810	SP2B-S2-200RE
2-3/16	071797	SP2B-S2-203R	071811	SP2B-S2-203RE
2-7/16	071798	SP2B-S2-207R	071812	SP2B-S2-207RE
2-11/16	071799	SP2B-S2-211R	071813	SP2B-S2-211RE
2-15/16	071800	SP2B-S2-215R	071814	SP2B-S2-215RE
3	071801	SP2B-S2-300R	071815	SP2B-S2-300RE
3-7/16	071802	SP2B-S2-307R	071816	SP2B-S2-307RE
3-15/16	071803	SP2B-S2-315R	071817	SP2B-S2-315RE

Shaft Size	A	B	C	D		F Bolt Dia.	G	H	J	L	M	R	S	"X Total Exp"	Y	Z
				Min	Max											
1-3/8																
1-7/16	2.53	6.88	2.25	4.69	6.00	1/2	1.28	1.13	3.88	2.75	1.88	0.86	1.67	3/16	0.020	1.80
1-1/2																
1-11/16	2.67	7.13	2.37	5.25	5.75	1/2	0.88	1.25	4.27	3.19	2.13	0.91	1.76	1/4	0.020	2.08
1-3/4																
1-15/16	2.84	8.38	2.44	5.93	6.36	5/8	0.97	1.31	4.56	3.44	2.25	0.89	1.95	1/4	0.020	2.30
2																
2-3/16	2.94	8.88	2.50	6.50	7.00	5/8	1.04	1.50	5.00	3.75	2.50	0.99	1.95	1/4	0.025	2.59
2-7/16	3.00	9.25	2.90	6.81	7.43	5/8	1.07	1.63	5.60	4.06	2.75	1.17	2.03	1/4	0.025	2.94
2-11/16																
2-15/16	3.59	10.44	2.91	7.70	8.40	3/4	1.23	1.88	6.38	4.70	3.25	1.11	2.48	1/4	0.025	3.47
3																
3-7/16	4.02	13.00	3.41	9.25	10.75	7/8	1.75	2.25	7.50	5.50	3.75	1.43	2.61	1/4	0.025	4.05
3-15/16	4.47	14.25	3.89	10.04	12.6	1	2.40	2.44	8.37	6.00	4.25	1.59	2.91	5/16	0.025	4.50

"A" & "R" Dimensions Do Not Include "Y" Dimension

FEATURES/BENEFITS PAGE B12-2	SPECIFICATION PAGE B12-4	HOW TO ORDER/NOMENCLATURE PAGE B12-5	DIMENSIONS PAGE B12-14
---------------------------------	-----------------------------	---	---------------------------



SELECTION

Steel S-2000-HD Pillow Block 2-Bolt With Type E Dimensions

Bearing Reference Guide

E-Family Roller Bearings

Specialty Tapered Products

S-2000

UNISPHERE II

IMPERIAL

UNIFIED SAF

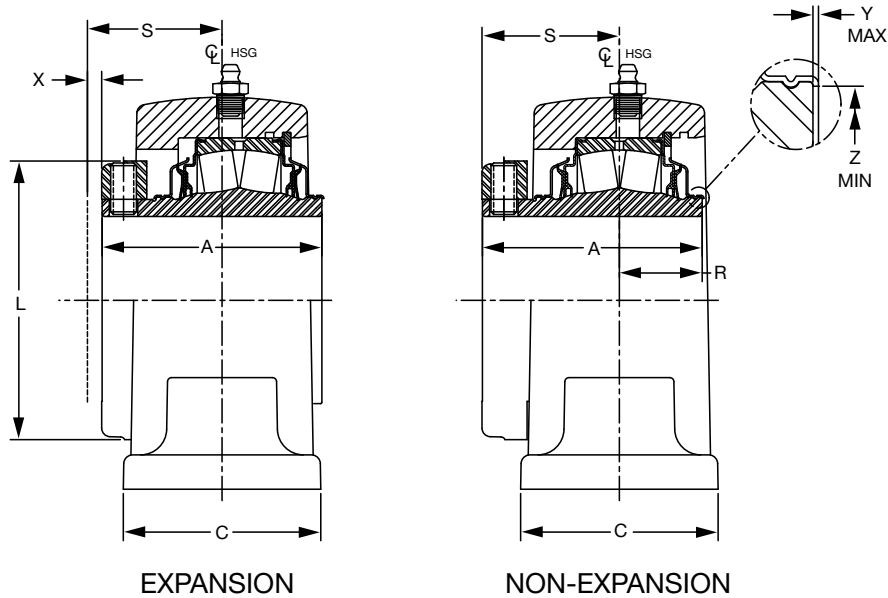
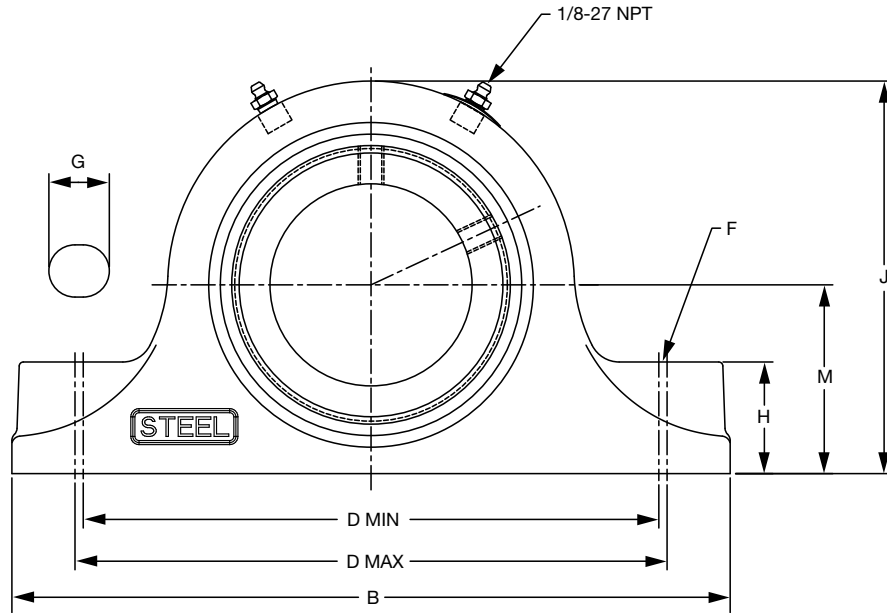

FEATURES/BENEFITS
PAGE B12-2

SPECIFICATION
PAGE B12-4

HOW TO ORDER/NOMENCLATURE
PAGE B12-5

DIMENSIONS
PAGE B12-14

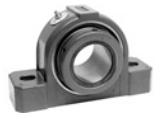

DIMENSIONS

Steel S-2000-HD Pillow Block 2-BOLT With Type E Dimensions

Shaft Size	Dodge Non-Expansion		Dodge Expansion	
	Part No.	Description	Part No.	Description
1-3/8	071940	SEP2B-S2-106R	071951	SEP2B-S2-106RE
1-7/16	071941	SEP2B-S2-107R	071952	SEP2B-S2-107RE
1-11/16	071942	SEP2B-S2-111R	071953	SEP2B-S2-111RE
1-15/16	071943	SEP2B-S2-115R	071954	SEP2B-S2-115RE
2	071944	SEP2B-S2-200R	071955	SEP2B-S2-200RE
2-3/16	071945	SEP2B-S2-203R	071956	SEP2B-S2-203RE
2-7/16	071946	SEP2B-S2-207R	071957	SEP2B-S2-207RE
2-11/16	071947	SEP2B-S2-211R	071958	SEP2B-S2-211RE
2-15/16	071948	SEP2B-S2-215R	071959	SEP2B-S2-215RE
3	071949	SEP2B-S2-300R	071960	SEP2B-S2-300RE
3-7/16	071950	SEP2B-S2-307R	071961	SEP2B-S2-307RE

Shaft Size	A	B	C	D		F Bolt Dia	G	H	J	L	M	R	S	X Total Exp	Y	Z	Set Screw Size	SS Torque In/lbs
				Min	Max													
1-3/8 1-7/16	2.53	6.88	2.25	4.69	5.88	1/2	1.22	1.13	3.84	2.55	1.88	1.03	1.50	5/32	0.020	1.80	5/16-18	165
1-11/16	2.67	7.88	2.38	5.70	6.50	1/2	1.02	1.25	4.26	3.01	2.13	0.98	1.69	3/16	0.020	2.08	5/16-18	165
1-15/16 2	2.84	8.88	2.44	6.00	7.12	5/8	1.32	1.31	4.47	3.26	2.25	1.08	1.76	7/32	0.020	2.30	3/8-16	290
2-3/16	2.94	9.63	2.50	6.50	7.88	5/8	1.45	1.50	5.00	3.50	2.50	1.06	1.88	1/4	0.025	2.60	3/8-16	290
2-7/16 2-11/16	3.20	10.25	2.90	6.88	8.62	5/8	1.63	1.63	5.71	3.86	2.75	1.20	2.00	1/4	0.025	2.95	3/8-16	290
2-15/16 3	3.59	11.63	2.91	7.88	9.62	3/4	1.75	1.88	6.32	4.61	3.13	1.34	2.25	1/4	0.025	3.47	1/2-13	620
3-7/16	4.01	13.50	3.41	9.38	11.25	7/8	1.94	2.25	7.69	5.50	3.75	1.51	2.50	1/4	0.025	4.05	1/2-13	620

"A" & "R" Dimensions Do Not Include "Y" Dimension

FEATURES/BENEFITS PAGE B12-2	SPECIFICATION PAGE B12-4	HOW TO ORDER/NOMENCLATURE PAGE B12-4	SELECTIONS PAGE B12-7
---------------------------------	-----------------------------	---	--------------------------

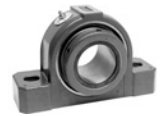

DIMENSIONS

S-2000 Pillow Block 4-BOLT BASE

Bearing Reference Guide

E-Family Roller Bearings

Specialty Tapered Products

S-2000

UNISPHERE II

IMPERIAL

UNIFIED SAF

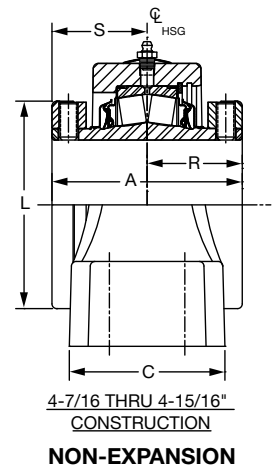
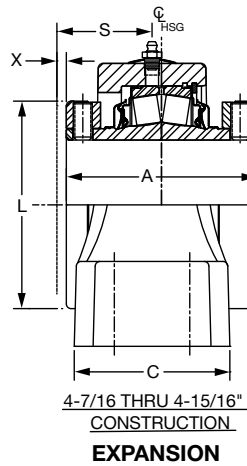
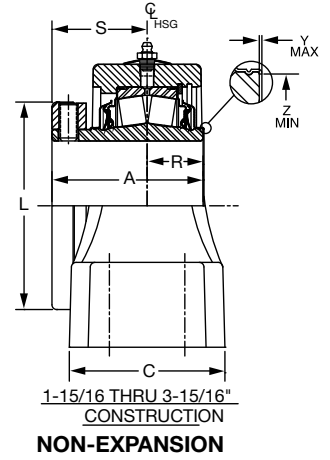
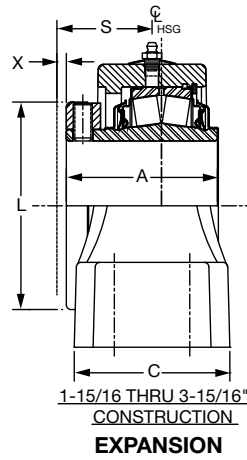
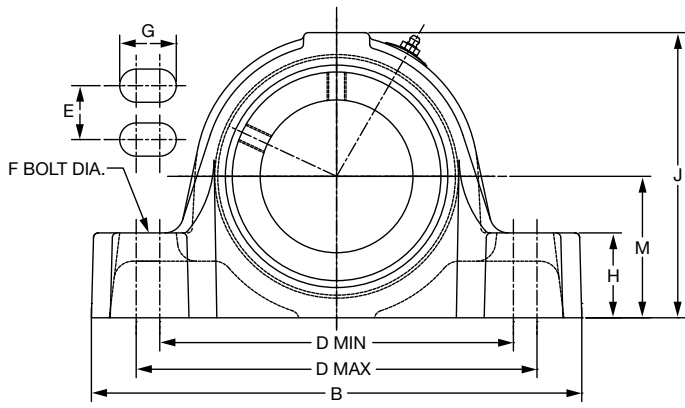

FEATURES/BENEFITS PAGE B12-2	SPECIFICATION PAGE B12-4	HOW TO ORDER/NOMENCLATURE PAGE B12-4	SELECTIONS PAGE B12-7
---------------------------------	-----------------------------	---	--------------------------



DIMENSIONS

S-2000 Pillow Block 4-BOLT BASE

Bearing	Shaft Size Inch	TRIDENT Seal				Labyrinth Seal			
		Non-Expansion		Expansion		Non-Expansion		Expansion	
		Part No.	Part Name	Part No.	Part Name	Part No.	Part Name	Part No.	Part Name
22210	1-15/16 2	070361	P4B-S2-115R	070379	P4B-S2-115RE	070397	P4B-S2-115L	070415	P4B-S2-115LE
		070362	P4B-S2-200R	070380	P4B-S2-200RE	070398	P4B-S2-200L	070416	P4B-S2-200LE
22211	2-3/16	070363	P4B-S2-203R	070381	P4B-S2-203RE	070399	P4B-S2-203L	070417	P4B-S2-203LE
22213	2-7/16	070365	P4B-S2-207R	070383	P4B-S2-207RE	070401	P4B-S2-207L	070419	P4B-S2-207LE
22215	2-11/16 2-15/16 3	070367	P4B-S2-211R	070385	P4B-S2-211RE	070403	P4B-S2-211L	070421	P4B-S2-211LE
		070368	P4B-S2-215R	070386	P4B-S2-215RE	070404	P4B-S2-215L	070422	P4B-S2-215LE
		070369	P4B-S2-300R	070387	P4B-S2-300RE	070405	P4B-S2-300L	070423	P4B-S2-300LE
22218	3-7/16	070371	P4B-S2-307R	070389	P4B-S2-307RE	070407	P4B-S2-307L	070425	P4B-S2-307LE
22220	3-15/16	070373	P4B-S2-315R	070391	P4B-S2-315RE	070409	P4B-S2-315L	070427	P4B-S2-315LE
22222	4-7/16	070375	P4B-S2-407R	070393	P4B-S2-407RE	070411	P4B-S2-407L	070429	P4B-S2-407LE
22226	4-15/16	070377	P4B-S2-415R	070395	P4B-S2-415RE	070413	P4B-S2-415L	070431	P4B-S2-415LE

Shaft Size	A	B	C	D		E	F Bolt Dia.	G	H	J	L	M	R	S	X Total Exp.	Y	Z
				Min	Max												
1-15/16 2	2.84	8.00	3.19	6.06	6.44	1.59	1/2	0.81	1.31	4.56	3.44	2.25	.84	2.0	1/4	0.020	2.30
2-3/16	2.94	8.88	3.25	6.56	6.94	1.69	1/2	0.81	1.50	5.00	3.75	2.50	0.91	2.03	1/4	0.025	2.60
2-7/16	3.20	9.25	3.38	6.94	7.31	1.75	1/2	0.81	1.63	5.59	4.06	2.75	1.08	2.13	1/4	0.025	2.95
2-11/16	3.59	10.44	3.75	7.94	8.31	1.88	5/8	0.94	1.88	6.44	4.70	3.25	1.09	2.50	1/4	0.025	3.47
2-15/16																	
3																	
3-7/16	4.02	13.00	4.13	9.38	10.63	2.00	3/4	1.50	2.25	7.56	5.50	3.75	1.44	2.58	1/4	0.025	4.05
3-15/16	4.47	15.25	4.50	12.13	12.88	2.25	3/4	1.25	2.44	8.44	6.00	4.25	1.64	2.83	5/16	0.025	4.50
4-7/16	6.53	16.50	4.75	13.00	14.00	2.50	3/4	1.38	2.75	9.63	6.45	4.75	3.08	3.45	3/8	N/A	N/A
4-15/16	6.91	18.63	5.38	15.00	16.00	2.75	7/8	1.50	3.00	11.13	7.45	5.50	3.27	3.64	3/8	N/A	N/A

FEATURES/BENEFITS PAGE B12-2	SPECIFICATION PAGE B12-4	HOW TO ORDER/NOMENCLATURE PAGE B12-4	SELECTIONS PAGE B12-7
---------------------------------	-----------------------------	---	--------------------------

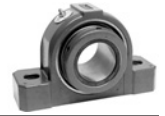

DIMENSIONS

S-2000 Pillow Block with Type E Dimensions 4-BOLT

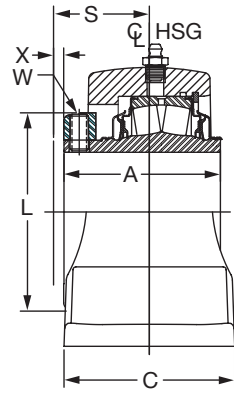
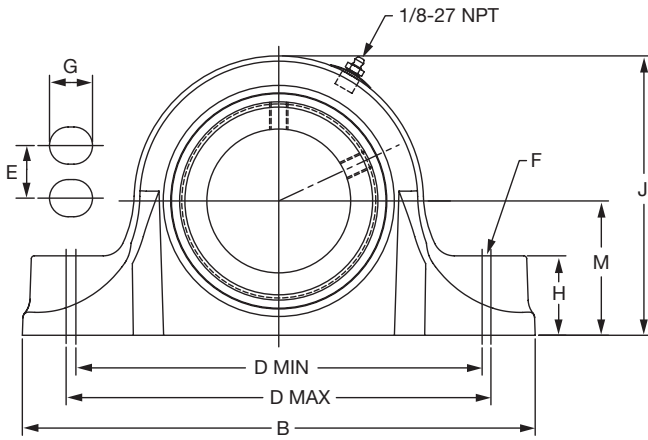

2-7/16 THRU 3-15/16"
CONSTRUCTION

EXPANSION

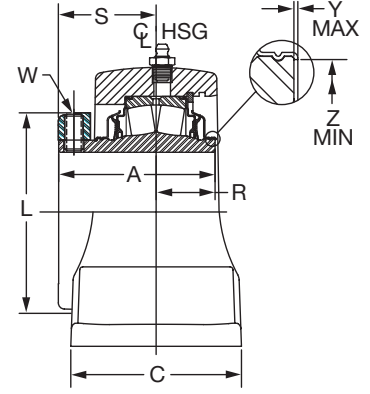

2-7/16 THRU 3-15/16"
CONSTRUCTION

NON-EXPANSION

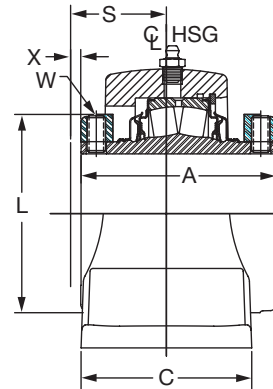

4-7/16 THRU 4-15/16"
CONSTRUCTION

EXPANSION

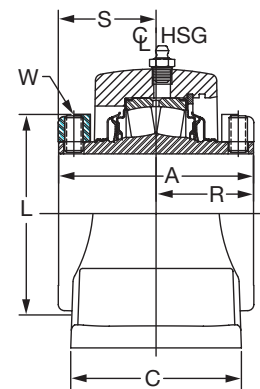

4-7/16 THRU 4-15/16"
CONSTRUCTION

NON-EXPANSION



DIMENSIONS

S-2000 Pillow Block with Type E Dimensions 4-BOLT

Bearing Series	Shaft Size*	TRIDENT Seal				Labyrinth Seal			
		Non Expansion		Expansion		Non Expansion		Expansion	
		Part No.	Part Name	Part No.	Part Name	Part No.	Part Name	Part No.	Part Name
22213	2-7/16	071433	EP4B-S2-207R	071441	EP4B-S2-207RE	071449	EP4B-S2-207L	071457	EP4B-S2-207LE
22215	2-11/16	071434	EP4B-S2-211R	071442	EP4B-S2-211RE	071450	EP4B-S2-211L	071458	EP4B-S2-211LE
	2-15/16	071435	EP4B-S2-215R	071443	EP4B-S2-215RE	071451	EP4B-S2-215L	071459	EP4B-S2-215LE
	3	071436	EP4B-S2-300R	071444	EP4B-S2-300RE	071452	EP4B-S2-300L	071460	EP4B-S2-300LE
22218	3-7/16	071437	EP4B-S2-307R	071445	EP4B-S2-307RE	071453	EP4B-S2-307L	071461	EP4B-S2-307LE
22220	3-15/16	071438	EP4B-S2-315R	071446	EP4B-S2-315RE	071454	EP4B-S2-315L	071462	EP4B-S2-315LE
22222	4-7/16	071439	EP4B-S2-407R	071447	EP4B-S2-407RE	071455	EP4B-S2-407L	071463	EP4B-S2-407LE
22226	4-15/16	071440	EP4B-S2-415R	071448	EP4B-S2-415RE	071456	EP4B-S2-415L	071464	EP4B-S2-415LE

*Consult Dodge For Sizes Not Listed

Shaft Size	A	B#	C#	D		E	F Bolt Dia.	G #	H #	J #	L	M	R	S	X Total Exp.	Y	Z	Set Screw Size	S/S Torque In/Lbs
				Min	Max														
2-7/16	3.20	10.50	3.49	8.31	8.69	1.87	5/8	0.87	1.63	5.72	4.06	2.75	1.20	2.00	1/4	0.025	2.94	3/8	290
2-11/16	3.59	12.00	4.00	9.18	9.82	2.13	5/8	1.00	1.88	6.33	4.61	3.13	1.34	2.25	1/4	0.025	3.47	1/2	620
2-15/16																			
3																			
3-7/16	4.01	13.50	4.49	10.75	11.25	2.37	3/4	1.13	2.25	7.69	5.50	3.75	1.51	2.50	1/4	0.025	4.05	1/2	620
3-15/16	4.47	15.25	4.50	12.25	12.75	2.25	3/4	1.13	2.44	8.70	6.00	4.25	1.34	3.13	5/16	0.025	4.50	5/8	1325
4-7/16	6.53	16.63	4.63	13.25	13.75	2.50	3/4	1.13	2.75	9.67	6.45	4.75	3.08	3.38	3/8	N/A	N/A	5/8	1325
4-15/16	6.91	18.50	5.13	15.25	15.75	2.87	7/8	1.25	3.00	11.16	7.45	5.50	3.29	3.62	3/8	N/A	N/A	5/8	1325

Notes: "A" And "R" Dimensions Do Not Include "Y" Dimension

Reference Dimension Only

FEATURES/BENEFITS PAGE B12-2	SPECIFICATION PAGE B12-4	HOW TO ORDER/NOMENCLATURE PAGE B12-4	SELECTIONS PAGE B12-7
---------------------------------	-----------------------------	---	--------------------------

DIMENSIONS



Steel S-2000-HD Pillow Block 4-Bolt

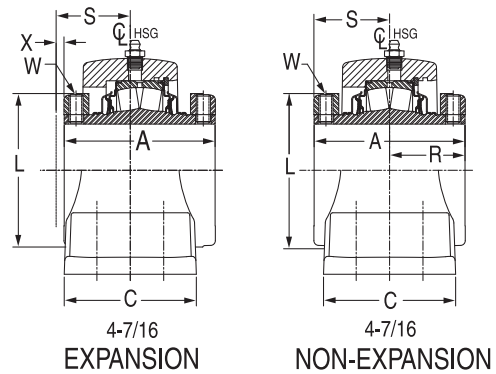
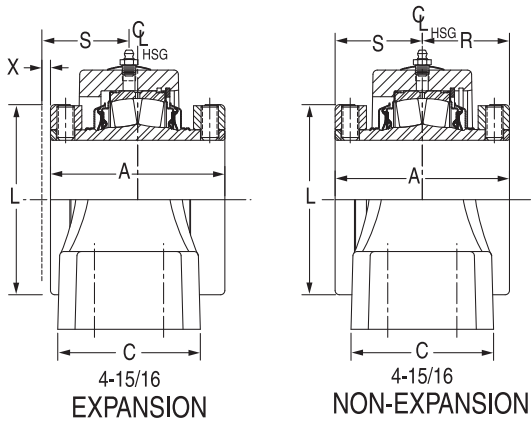
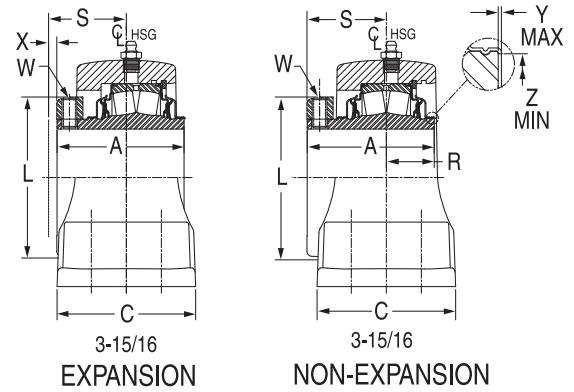
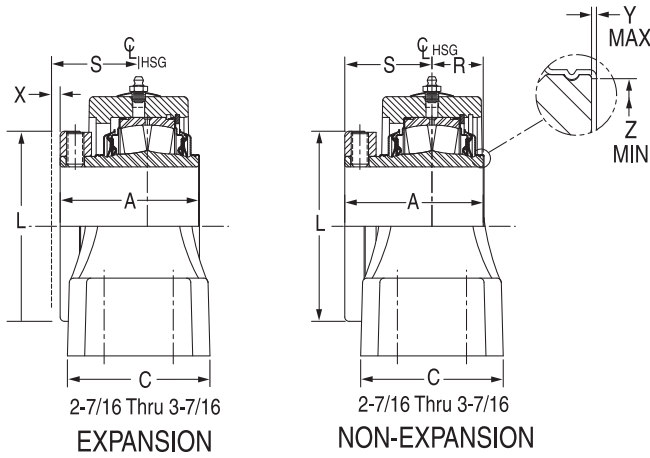
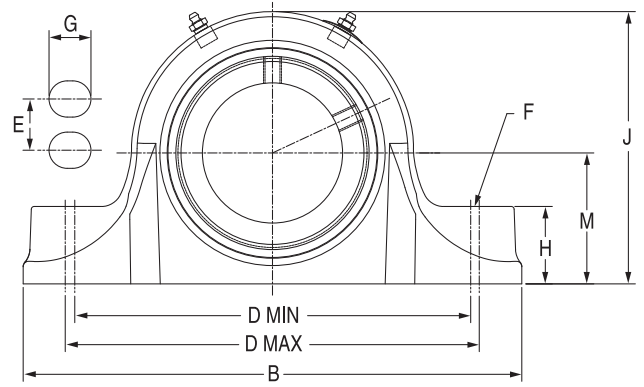
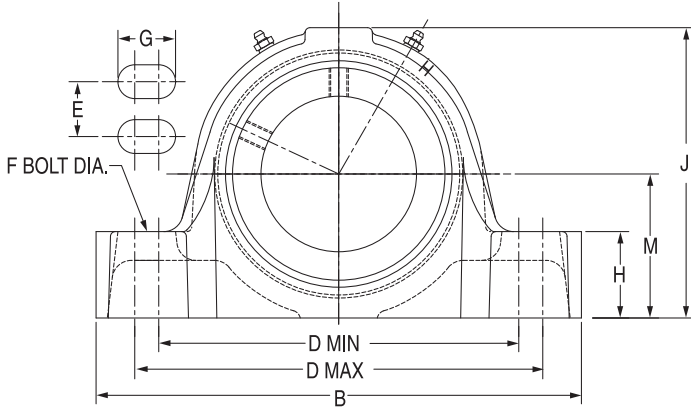

FEATURES/BENEFITS
PAGE B12-2

SPECIFICATION
PAGE B12-4

HOW TO ORDER/NOMENCLATURE
PAGE B12-4

SELECTIONS
PAGE B12-7

DIMENSIONS

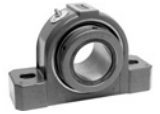

Steel S-2000-HD Pillow Block 4-Bolt

Bearing Reference Guide

E-Family Roller Bearings

Specialty Tapered Products

S-2000

UNISPHERE II

IMPERIAL

UNIFIED SAF

Shaft Size	Dodge Non-Expansion		Dodge Expansion	
	Dodge Part No.	Description	Dodge Part No.	Description
2-7/16	071821	SP4B-S2-207R	071832	SP4B-S2-207RE
2-11/16	071822	SP4B-S2-211R	071833	SP4B-S2-211RE
2-15/16	071823	SP4B-S2-215R	071834	SP4B-S2-215RE
3	071824	SP4B-S2-300R	071835	SP4B-S2-300RE
3-7/16	071825	SP4B-S2-307R	071836	SP4B-S2-307RE
3-15/16	071826	SP4B-S2-315R	071837	SP4B-S2-315RE
4-7/16	071827	SP4B-S2-407R	071838	SP4B-S2-407RE
4-15/16	071828	SP4B-S2-415R	071839	SP4B-S2-415RE

Shaft Size	A	B	C	D		E	F Bolt Dia.	G	H	J	L	M	R	S	X Total Exp	Y	Z
				Min	Max												
2-7/16 2-11/16	3.20	9.25	3.00	6.88	7.63	1.75	1/2	1.06	1.63	5.61	4.06	2.75	1.19	2.90	1/4	0.025	2.94
2-15/16 3	3.59	10.44	3.13	7.60	9.10	1.88	5/8	1.43	1.88	6.44	4.70	3.00	1.14	2.46	1/4	0.025	3.47
3-7/16	4.02	12.30	3.75	8.88	10.88	2.00	3/4	1.88	2.25	7.56	5.50	3.75	1.48	2.54	1/4	0.025	4.05
3-15/16	4.47	14.88	4.31	10.88	13.38	2.25	3/4	2.13	2.44	8.70	6.00	4.25	1.25	3.22	5/16	0.025	4.50
4-7/16	6.53	16.13	4.75	11.88	14.5	2.50	3/4	2.19	2.75	9.67	6.45	4.75	2.87	3.66	3/8	0.036	5.00
4-15/16	6.91	17.50	5.03	15.13	15.88	2.75	7/8	1.37	3.00	11.12	7.45	5.50	3.35	3.56	3/8	0.036	5.84

"A" & "R" Dimensions Do Not Include "Y" Dimension

FEATURES/BENEFITS PAGE B12-2	SPECIFICATION PAGE B12-4	HOW TO ORDER/NOMENCLATURE PAGE B12-4	SELECTIONS PAGE B12-7
---------------------------------	-----------------------------	---	--------------------------



DIMENSIONS

Steel S2000-HD Pillow Block 4-Bolt With Type E Dimensions

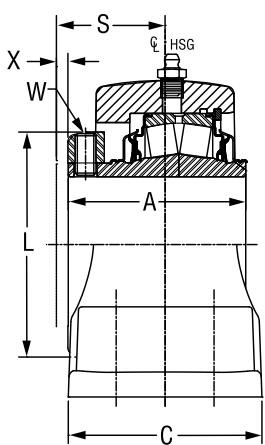
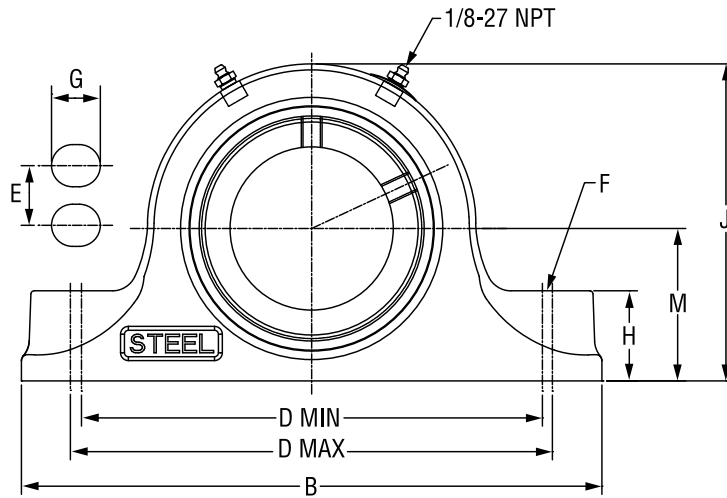

2-7/16 THRU 3-15/16
CONSTRUCTION
EXPANSION

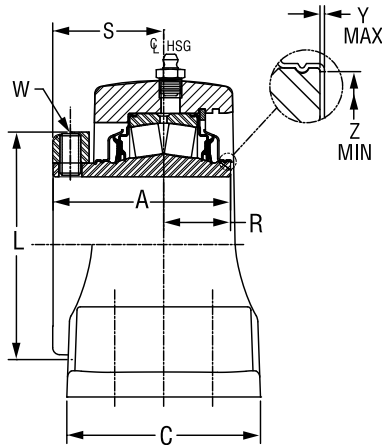

2-7/16 THRU 3-15/16
CONSTRUCTION
NON-EXPANSION

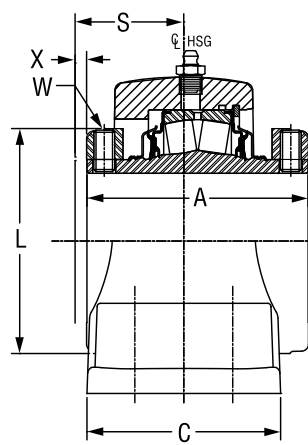

4-7/16 THRU 4-15/16
CONSTRUCTION
EXPANSION

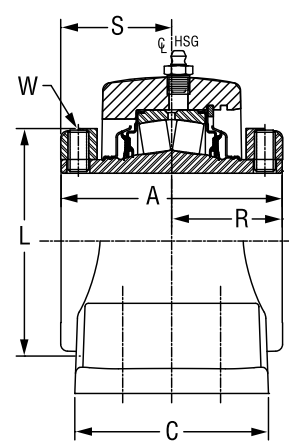

4-7/16 THRU 4-15/16
CONSTRUCTION
NON-EXPANSION



DIMENSIONS

Steel S2000-HD Pillow Block 4-Bolt With Type E Dimensions

Shaft Size	Dodge Non-Expansion		Dodge Expansion	
	Dodge Part No.	Description	Dodge Part No.	Description
2-7/16	071962	SEP4B-S2-207R	071970	SEP4B-S2-207RE
2-11/16	071963	SEP4B-S2-211R	071971	SEP4B-S2-211RE
2-15/16	071964	SEP4B-S2-215R	071972	SEP4B-S2-215RE
3	071965	SEP4B-S2-300R	071973	SEP4B-S2-300RE
3-7/16	071966	SEP4B-S2-307R	071974	SEP4B-S2-307RE
3-15/16	071967	SEP4B-S2-315R	071975	SEP4B-S2-315RE
4-7/16	071968	SEP4B-S2-407R	071976	SEP4B-S2-407RE
4-15/16	071969	SEP4B-S2-415R	071977	SEP4B-S2-415RE

Shaft Size	A	B	C	D Min	D Max	E	F Bolt Dia	G	H
2-7/16	3.20	10.25	3.25	7.13	8.75	1.88	5/8	1.57	1.63
2-11/16	3.59	10.83	3.38	8.00	9.60	2.12	5/8	1.56	1.88
2-15/16									
3	4.01	13.63	3.75	9.25	11.25	2.38	3/4	1.88	2.25
3-7/16									
3-15/16	4.47	14.88	4.31	10.88	13.88	2.25	3/4	2.13	2.44
4-7/16	6.53	16.13	4.75	11.88	14.50	2.50	3/4	2.19	2.75
4-15/16	6.91	17.50	5.04	15.13	15.88	2.88	7/8	1.38	3.00

"A" & "R" Dimensions Do Not Include "Y" Dimension

Reference Dimension Only

Shaft Size	J	L	M	R	S	X Total Exp	Y	Z	Set Screw Size	S/S Torque In/Lbs
2-7/16	5.71	3.86	2.75	1.20	2.00	1/4	0.025	2.94	3/8	290
2-11/16	6.32	4.61	3.13	1.34	2.25	1/4	0.025	3.47	1/2	620
2-15/16										
3	7.69	5.50	3.75	1.51	2.50	1/4	0.025	4.05	1/2	620
3-7/16										
3-15/16	8.70	6.00	4.25	1.25	3.22	5/16	0.025	4.50	5/8	1325
4-7/16	9.67	6.45	4.75	2.87	3.66	3/8	0.036	5.00	5/8	1325
4-15/16	11.16	7.45	5.50	3.29	3.62	3/8	N/A	N/A	5/8	1325

"A" & "R" Dimensions Do Not Include "Y" Dimension

FEATURES/BENEFITS PAGE B12-2	SPECIFICATION PAGE B12-4	HOW TO ORDER/NOMENCLATURE PAGE B12-4	SELECTIONS PAGE B12-7
---------------------------------	-----------------------------	---	--------------------------

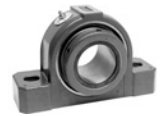

DIMENSIONS

S-2000 Flange Bearing - Round

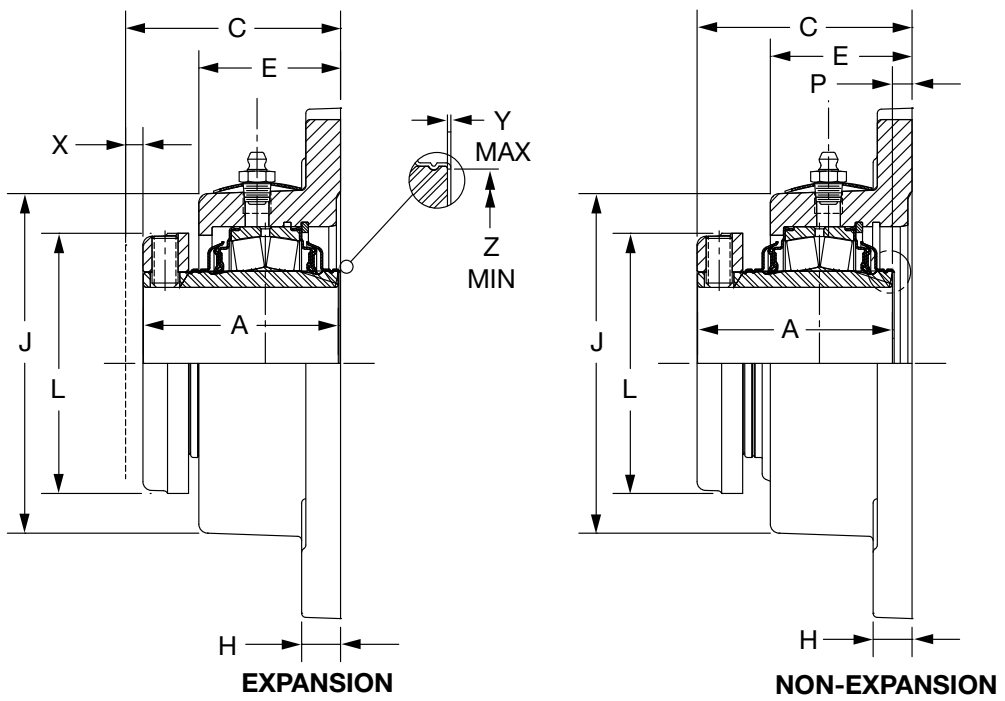
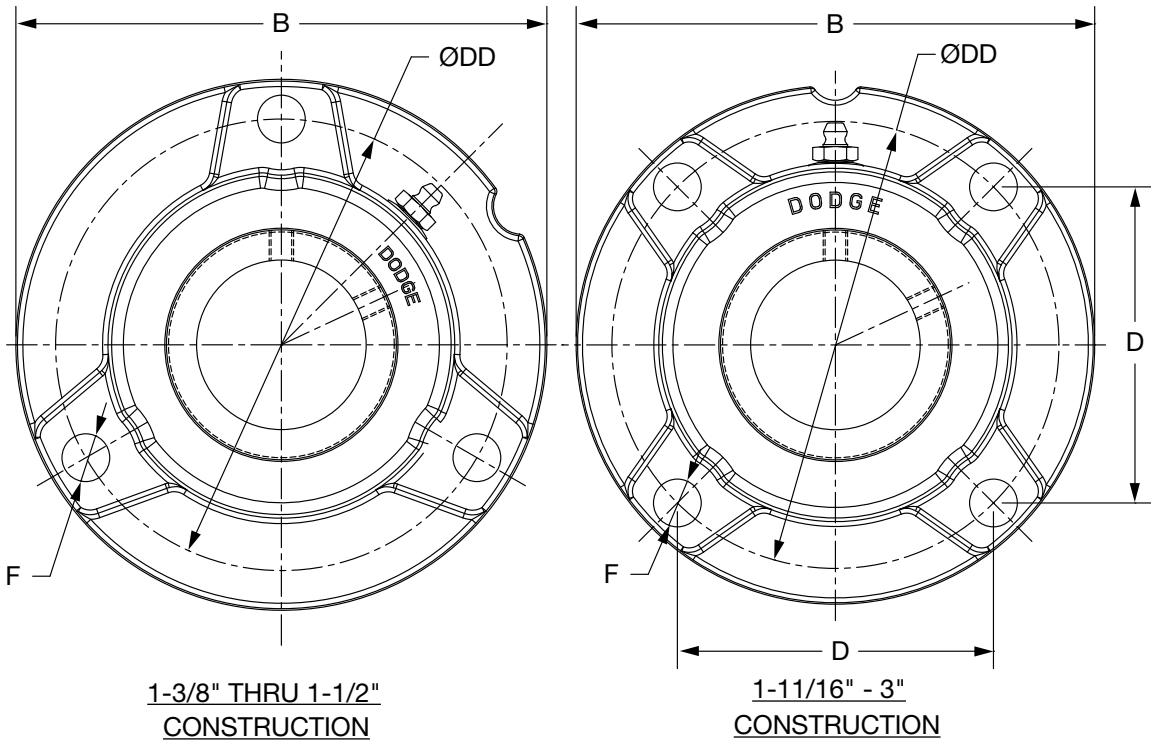

FEATURES/BENEFITS
PAGE B12-2

SPECIFICATION
PAGE B12-4

HOW TO ORDER/NOMENCLATURE
PAGE B12-4

SELECTIONS
PAGE B12-7

DIMENSIONS

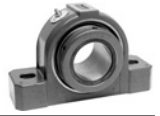

S-2000 Flange Bearing - Round

Bearing	Shaft Size Inch	TRIDENT Seal				Labyrinth Seal			
		Non-Expansion		Expansion		Non-Expansion		Expansion	
		Part No.	Part Name	Part No.	Part Name	Part No.	Part Name	Part No.	Part Name
22208	1 - 3/8	070436	F3R-S2-106R	070470	F3R-S2-106RE	070491	F3R-S2-106L	070523	F3R-S2-106LE
	1 - 7/16	070437	F3R-S2-107R	070471	F3R-S2-107RE	070492	F3R-S2-107L	070524	F3R-S2-107LE
	1 - 1/2	070438	F3R-S2-108R	070472	F3R-S2-108RE	070493	F3R-S2-108L	070525	F3R-S2-108LE
22209	1 - 11/16	070440	F4R-S2-111R	070474	F4R-S2-111RE	070495	F4R-S2-111L	070527	F4R-S2-111LE
	1 - 3/4	070441	F4R-S2-112R	070475	F4R-S2-112RE	070496	F4R-S2-112L	070528	F4R-S2-112LE
22210	1 - 15/16	070442	F4R-S2-115R	070476	F4R-S2-115RE	070497	F4R-S2-115L	070529	F4R-S2-115LE
	2	070443	F4R-S2-200R	070477	F4R-S2-200RE	070498	F4R-S2-200L	070530	F4R-S2-200LE
22211	2 - 3/16	070444	F4R-S2-203R	070478	F4R-S2-203RE	070499	F4R-S2-203L	070531	F4R-S2-203LE
22213	2-7/16	070446	F4R-S2-207R	070480	F4R-S2-207RE	070501	F4R-S2-207L	070533	F4R-S2-207LE
22215	2-11/16	070448	F4R-S2-211R	070482	F4R-S2-211RE	070503	F4R-S2-211L	070535	F4R-S2-211LE
	2-15/16	070449	F4R-S2-215R	070483	F4R-S2-215RE	070504	F4R-S2-215L	070536	F4R-S2-215LE
	3	070450	F4R-S2-300R	070484	F4R-S2-300RE	070505	F4R-S2-300L	070537	F4R-S2-300LE

Shaft Size	A	B	C	D	DD	E	F Bolt Dia.	H	J	L	P	X Total Exp.	Y	Z
1 - 3/8														
1 - 7/16	2.53	5.88	2.77	3.53	5.00	1.80	1/2*	0.50	3.84	2.75	0.23	3/16	0.020	1.80
1 - 1/2														
1 - 11/16	2.67	6.38	2.97	3.89	5.50	1.89	1/2**	0.50	4.34	3.19	0.30	1/4	0.020	2.08
1 - 3/4														
1 - 15/16	2.84	6.69	3.14	4.06	5.75	1.92	1/2**	0.56	4.59	3.44	0.30	1/4	0.020	2.30
2														
2 - 3/16	2.94	7.38	3.23	4.50	6.38	2.05	5/8**	0.56	4.98	3.75	0.30	1/4	0.025	2.60
2-7/16	3.20	7.75	3.50	4.77	6.75	2.38	5/8**	0.77	5.50	4.06	0.30	1/4	0.025	2.95
2-11/16														
2-15/16	3.59	9.25	3.89	5.56	7.88	2.39	3/4**	0.88	6.36	4.70	0.30	1/4	0.025	3.47
3														

* 3 Equally spaced bolt holes

** 4 Equally spaced bolt holes

FEATURES/BENEFITS PAGE B12-2	SPECIFICATION PAGE B12-4	HOW TO ORDER/NOMENCLATURE PAGE B12-4	SELECTIONS PAGE B12-7
---------------------------------	-----------------------------	---	--------------------------



DIMENSIONS

S-2000 Flange Bearing - Square

Bearing Reference Guide

E-Family Roller Bearings

Specialty Tapered Products

S-2000

UNISPHERE II

IMPERIAL

UNIFIED SAF

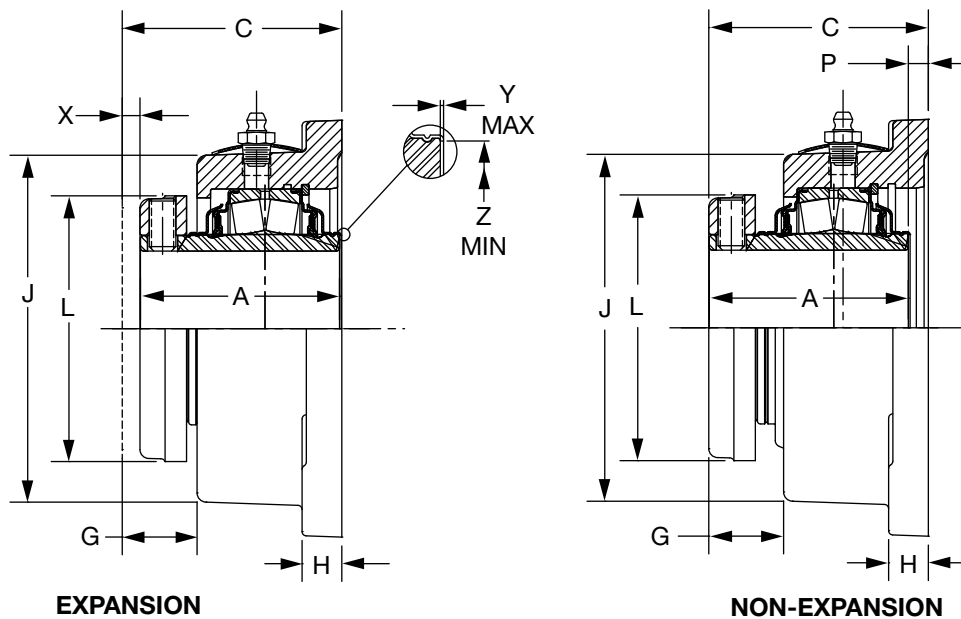
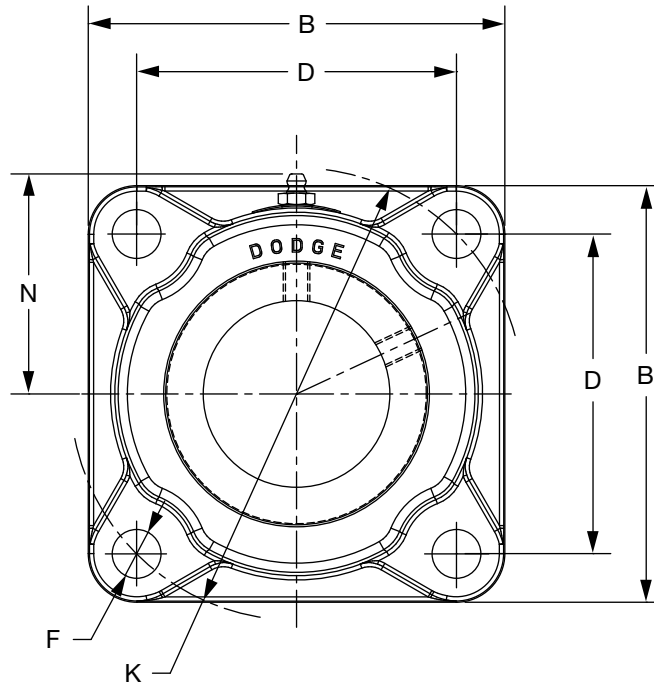

FEATURES/BENEFITS PAGE B12-2	SPECIFICATION PAGE B12-4	HOW TO ORDER/NOMENCLATURE PAGE B12-4	SELECTIONS PAGE B12-7
---------------------------------	-----------------------------	---	--------------------------

DIMENSIONS

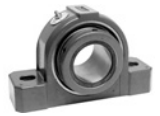

S-2000 Flange Bearing - Square

Bearing	Shaft Size Inch	TRIDENT Seal				Labyrinth Seal			
		Non-Expansion		Expansion		Non-Expansion		Expansion	
		Part No.	Part Name	Part No.	Part Name	Part No.	Part Name	Part No.	Part Name
22208	1-3/8	070541	F4S-S2-106R	070564	F4S-S2-106RE	070600	F4S-S2-106L	070853	F4S-S2-106LE
	1-7/16	070542	F4S-S2-107R	070565	F4S-S2-107RE	070601	F4S-S2-107L	070854	F4S-S2-107LE
	1-1/2	070543	F4S-S2-108R	070566	F4S-S2-108RE	070602	F4S-S2-108L	070855	F4S-S2-108LE
22209	1-11/16	070545	F4S-S2-111R	070568	F4S-S2-111RE	070604	F4S-S2-111L	070857	F4S-S2-111LE
	1-3/4	070546	F4S-S2-112R	070569	F4S-S2-112RE	070605	F4S-S2-112L	070858	F4S-S2-112LE
22210	1-15/16	070547	F4S-S2-115R	070570	F4S-S2-115RE	070606	F4S-S2-115L	070859	F4S-S2-115LE
	2	070548	F4S-S2-200R	070571	F4S-S2-200RE	070607	F4S-S2-200L	070860	F4S-S2-200LE
22211	2-3/16	070549	F4S-S2-203R	070572	F4S-S2-203RE	070608	F4S-S2-203L	070861	F4S-S2-203LE
22213	2-7/16	070551	F4S-S2-207R	070574	F4S-S2-207RE	070610	F4S-S2-207L	070863	F4S-S2-207LE
22215	2-11/16	070553	F4S-S2-211R	070576	F4S-S2-211RE	070612	F4S-S2-211L	070865	F4S-S2-211LE
	2-15/16	070554	F4S-S2-215R	070577	F4S-S2-215RE	070613	F4S-S2-215L	070866	F4S-S2-215LE
	3	070555	F4S-S2-300R	070578	F4S-S2-300RE	070614	F4S-S2-300L	070867	F4S-S2-300LE
22218	3-7/16	070557	F4S-S2-307R	070580	F4S-S2-307RE	070616	F4S-S2-307L	070869	F4S-S2-307LE
22220	3-15/16	070559	F4S-S2-315R	070582	F4S-S2-315RE	070618	F4S-S2-315L	070871	F4S-S2-315LE

Shaft Size	A	B	C	D	F Bolt Dia	G	H	J	K	L	N	P	X Total Exp.	Y	Z
1-3/8															
1-7/16	2.53	4.75	2.77	3.53	1/2	0.99	0.50	3.81	5.00	2.75	2.48	0.23	3/16	0.020	1.80
1-1/2															
1-11/16	2.67	5.13	2.97	3.89	1/2	1.08	0.50	4.41	5.50	3.19	2.78	0.30	1/4	0.020	2.08
1-3/4															
1-15/16	2.84	5.30	3.16	4.06	1/2	1.23	0.56	4.97	5.75	3.44	2.91	0.31	1/4	0.020	2.30
2															
2-3/16	2.94	5.88	3.25	4.52	5/8	1.20	0.56	5.02	6.38	3.75	3.09	0.31	1/4	0.025	2.60
2-7/16	3.20	6.13	3.52	4.78	5/8	1.14	0.64	5.63	6.75	4.06	3.41	0.31	1/4	0.025	2.95
2-11/16															
2-15/16	3.59	7.19	3.91	5.56	3/4	1.52	0.75	6.50	7.88	4.70	3.84	0.31	1/4	0.025	3.47
3															
3-7/16	4.00	8.25	4.31	6.72	3/4	1.44	0.94	7.48	9.50	5.50	4.33	0.31	1/4	0.025	4.05
3-15/16	4.47	9.25	4.84	7.61	7/8	1.55	1.06	8.22	10.75	6.00	4.70	0.38	5/16	0.025	4.50

FEATURES/BENEFITS PAGE B12-2	SPECIFICATION PAGE B12-4	HOW TO ORDER/NOMENCLATURE PAGE B12-4	SELECTIONS PAGE B12-7
---------------------------------	-----------------------------	---	--------------------------



S-2000 Flange Bearing - Square with Type E Dimensions

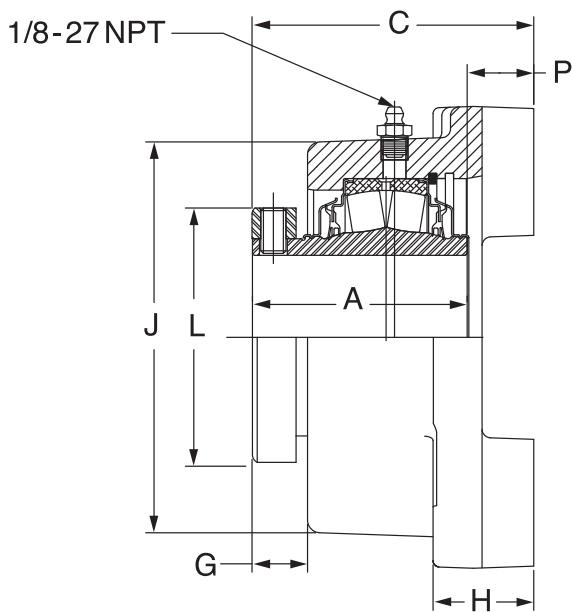
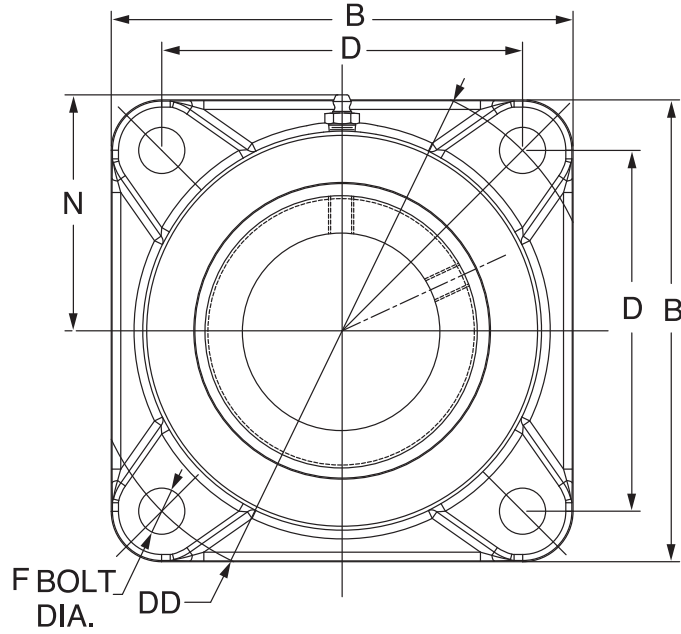

NON-EXPANSION

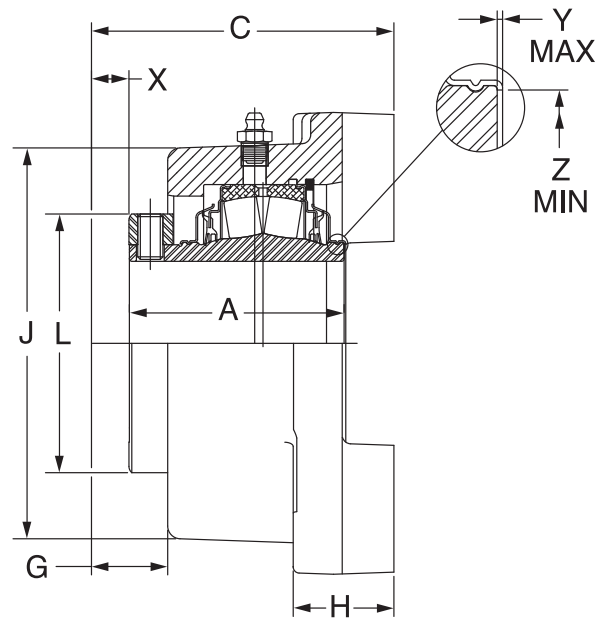

EXPANSION

FEATURES/BENEFITS PAGE B12-2	SPECIFICATION PAGE B12-4	HOW TO ORDER/NOMENCLATURE PAGE B12-4	SELECTIONS PAGE B12-7
---------------------------------	-----------------------------	---	--------------------------



DIMENSIONS

S-2000 Flange Bearing - Square with Type E Dimensions

Bearing Series	Shaft Size*	TRIDENT Seal				Labyrinth Seal			
		Non Expansion		Expansion		Non Expansion		Expansion	
		Part No.	Part Name	Part No.	Part Name	Part No.	Part Name	Part No.	Part Name
22208	1-3/8	071469	EF4B-S2-106R	071482	EF4B-S2-106RE	071495	EF4B-S2-106L	071508	EF4B-S2-106LE
	1-7/16	071470	EF4B-S2-107R	071483	EF4B-S2-107RE	071496	EF4B-S2-107L	071509	EF4B-S2-107LE
22209	1-11/16	071471	EF4B-S2-111R	071484	EF4B-S2-111RE	071497	EF4B-S2-111L	071510	EF4B-S2-111LE
22210	1-15/16	071472	EF4B-S2-115R	071485	EF4B-S2-115RE	071498	EF4B-S2-115L	071511	EF4B-S2-115LE
	2	071473	EF4B-S2-200R	071486	EF4B-S2-200RE	071499	EF4B-S2-200L	071512	EF4B-S2-200LE
22211	2-3/16	071474	EF4B-S2-203R	071487	EF4B-S2-203RE	071500	EF4B-S2-203L	071513	EF4B-S2-203LE
22213	2-7/16	071475	EF4B-S2-207R	071488	EF4B-S2-207RE	071501	EF4B-S2-207L	071514	EF4B-S2-207LE
	2-11/16	071476	EF4B-S2-211R	071489	EF4B-S2-211RE	071502	EF4B-S2-211L	071515	EF4B-S2-211LE
22215	2-15/16	071477	EF4B-S2-215R	071490	EF4B-S2-215RE	071503	EF4B-S2-215L	071516	EF4B-S2-215LE
	3	071478	EF4B-S2-300R	071491	EF4B-S2-300RE	071504	EF4B-S2-300L	071517	EF4B-S2-300LE
22218	3-7/16	071479	EF4B-S2-307R	071492	EF4B-S2-307RE	071505	EF4B-S2-307L	071518	EF4B-S2-307LE
22220	3-15/16	071480	EF4B-S2-315R	071493	EF4B-S2-315RE	071506	EF4B-S2-315L	071519	EF4B-S2-315LE
22222	4-7/16	071481	EF4B-S2-407R	071494	EF4B-S2-407RE	071507	EF4B-S2-407L	071520	EF4B-S2-407LE

*Consult Dodge For Sizes Not Listed

Shaft Size	A	B #	C #	D	DD	F Bolt Dia.	G	H #	J #	L	N	P	X Total Exp.	Y	Z	Set Screw Size	S/S Torque In/Lbs
1-3/8 1-7/16	2.53	4.62	3.06	3.50	4.95	1/2	0.57	1.06	3.88	2.55	2.34	0.53	5/32	0.020	1.80	5/16-18	165
1-11/16	2.67	5.37	3.50	4.13	5.83	1/2	0.53	1.19	4.18	3.01	2.51	0.84	3/16	0.020	2.08	5/16-18	165
1-15/16 2	2.84	5.62	3.63	4.37	6.19	1/2	0.65	1.18	4.36	3.44	2.60	0.78	7/32	0.020	2.30	3/8-16	290
2-3/16	2.94	6.25	3.87	4.87	6.89	5/8	0.60	1.38	4.88	3.50	2.88	0.93	1/4	0.025	2.60	3/8-16	290
2-7/16	3.20	6.88	4.19	5.37	7.60	5/8	0.83	1.50	5.81	4.06	3.32	0.98	1/4	0.025	2.95	3/8-16	290
2-11/16 2-15/16 3	3.59	7.76	4.69	6.00	8.49	3/4	0.88	1.61	6.30	4.61	3.58	1.09	1/4	0.025	3.47	1/2-13	620
3-7/16	4.01	9.25	5.25	7.00	9.90	3/4	0.96	1.87	7.44	5.50	4.15	1.24	1/4	0.025	4.05	1/2-13	620
3-15/16	4.48	10.25	6.50	7.75	10.96	7/8	1.00	2.12	8.27	6.00	4.58	2.02	5/16	0.025	4.50	5/8-11	1325
4-7/16	6.53	10.88	7.10	8.75	12.37	7/8	1.39	2.43	9.13	6.45	5.01	0.56	3/8	N/A	N/A	5/8-11	1325

Note(S): "P" Dimension Is For Non-Expansion Only

"A" And "P" Dimensions Do Not Include "Y" Dimension

- Reference Dimensions Only

FEATURES/BENEFITS PAGE B12-2	SPECIFICATION PAGE B12-4	HOW TO ORDER/NOMENCLATURE PAGE B12-4	SELECTIONS PAGE B12-7
---------------------------------	-----------------------------	---	--------------------------



DIMENSIONS

Steel S-2000-HD Flange 4-Bolt

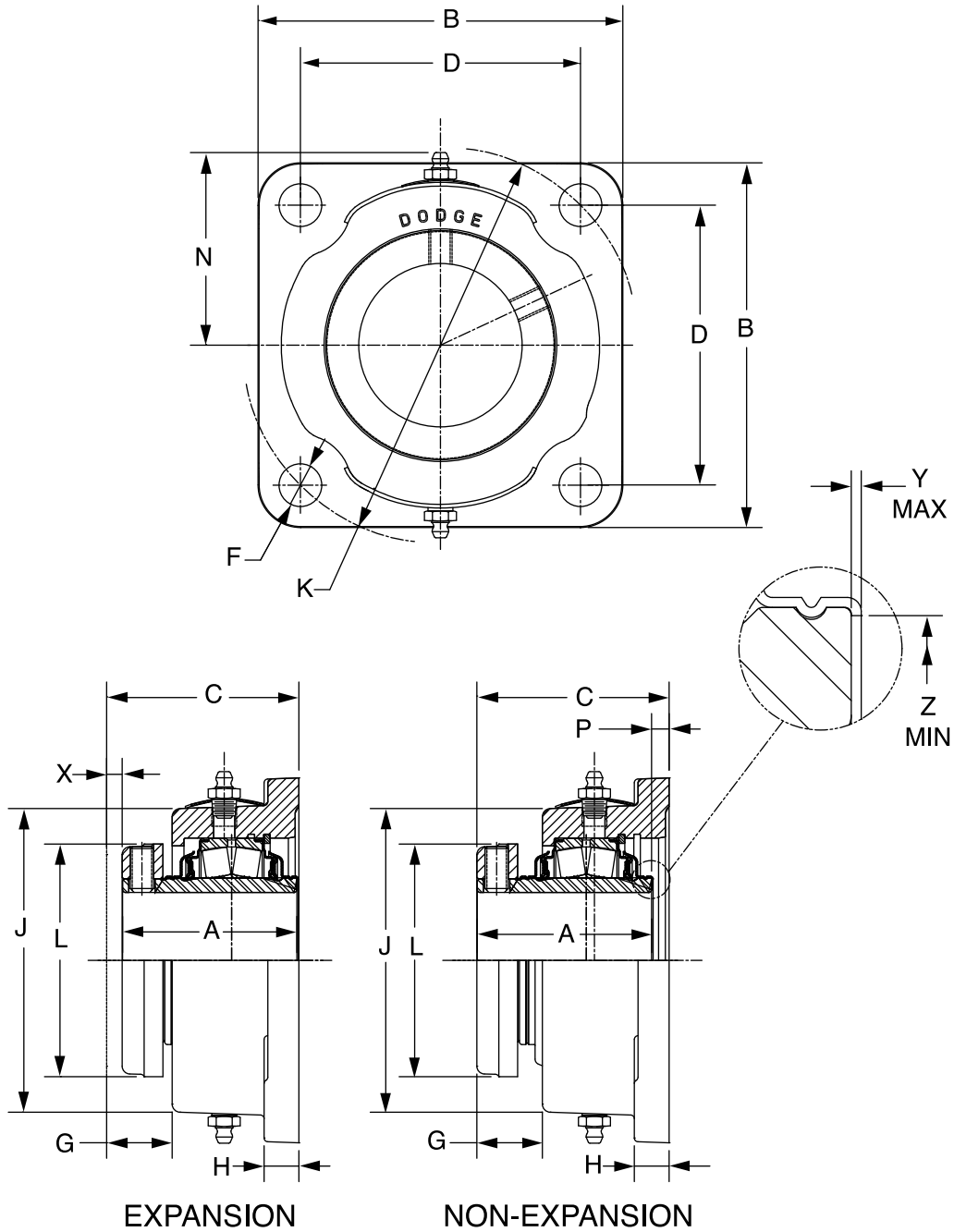

FEATURES/BENEFITS
PAGE B12-2

SPECIFICATION
PAGE B12-4

HOW TO ORDER/NOMENCLATURE
PAGE B12-4

SELECTIONS
PAGE B12-7

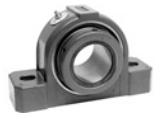

DIMENSIONS

Steel S-2000-HD Flange 4-Bolt

Shaft Size	Dodge Non-Expansion		Dodge Expansion	
	Dodge Part No.	Description	Dodge Part No.	Description
1-3/8	072386	SF4S-S2-106R	072400	SF4S-S2-106RE
1-7/16	072387	SF4S-S2-107R	072401	SF4S-S2-107RE
1-1/2	072388	SF4S-S2-108R	072402	SF4S-S2-108RE
1-11/16	072389	SF4S-S2-111R	072403	SF4S-S2-111RE
1-3/4	072390	SF4S-S2-112R	072404	SF4S-S2-112RE
1-15/16	072391	SF4S-S2-115R	072405	SF4S-S2-115RE
2	072392	SF4S-S2-200R	072406	SF4S-S2-200RE
2-3/16	072393	SF4S-S2-203R	072407	SF4S-S2-203RE
2-7/16	072394	SF4S-S2-207R	072408	SF4S-S2-207RE
2-11/16	072395	SF4S-S2-211R	072409	SF4S-S2-211RE
2-15/16	072396	SF4S-S2-215R	072410	SF4S-S2-215RE
3	072397	SF4S-S2-300R	072411	SF4S-S2-300RE
3-7/16	072398	SF4S-S2-307R	072412	SF4S-S2-307RE
3-15/16	072399	SF4S-S2-315R	072413	SF4S-S2-315RE

Shaft Size	A	B	C	D	F Bolt Dia.	G	H	J	K	L	N	P	X Total Exp	Y	Z
1-3/8															
1-7/16	2.53	4.62	2.77	3.54	1/2	0.76	0.88	3.70	5.00	2.75	2.25	0.24	3/16	0.02	1.80
1-1/2															
1-11/16	2.67	5.37	2.87	3.89	1/2	0.77	0.88	4.41	5.50	3.19	2.62	0.20	1/4	0.02	2.08
1-3/4															
1-15/16	2.84	5.18	3.16	4.07	1/2	0.91	0.91	4.66	5.75	3.44	2.75	0.32	1/4	0.02	2.30
2															
2-3/16	2.94	5.87	3.16	4.51	5/8	0.83	0.75	5.03	6.38	3.75	2.93	0.22	1/4	0.02	2.59
2-7/16	3.20	6.18	3.34	4.77	5/8	0.72	1.00	5.63	6.75	4.06	3.23	0.14	1/4	0.025	2.94
2-11/16															
2-15/16	3.59	7.18	3.87	5.57	3/4	1.04	1.06	6.51	7.88	4.70	3.75	0.28	1/4	0.025	3.47
3															
3-7/16	4.00	8.37	4.11	6.72	3/4	0.78	1.28	7.49	9.50	5.50	4.17	0.11	1/4	0.025	4.05
3-15/16	4.48	9.49	4.84	7.60	1	0.85	1.50	8.22	10.75	6.00	4.68	0.36	5/32	0.025	4.50

"P" Dimension Is For Non-Expansion Only

"A" & "P" Dimensions Do Not Include "Y" Dimension

FEATURES/BENEFITS PAGE B12-2	SPECIFICATION PAGE B12-4	HOW TO ORDER/NOMENCLATURE PAGE B12-4	SELECTIONS PAGE B12-7
---------------------------------	-----------------------------	---	--------------------------

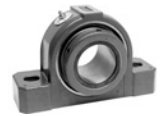

DIMENSIONS

S-2000 Piloted Flange

Bearing Reference Guide

E-Family Roller Bearings

Specialty Tapered Products

S-2000

UNISPHERE II

IMPERIAL

UNIFIED SAF

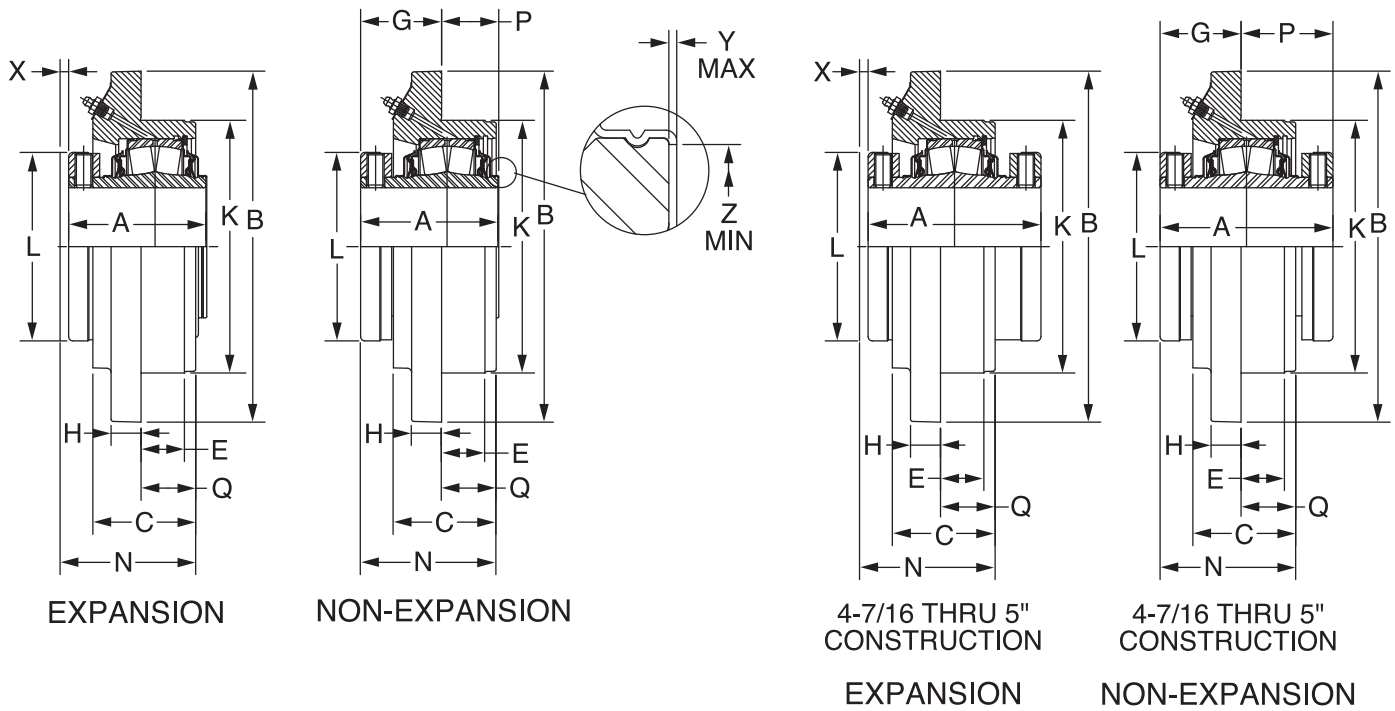
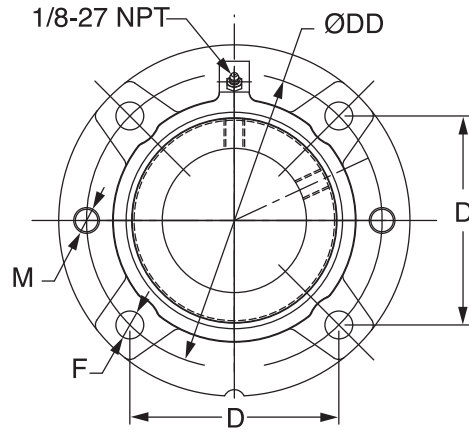

FEATURES/BENEFITS PAGE B12-2	SPECIFICATION PAGE B12-4	HOW TO ORDER/NOMENCLATURE PAGE B12-4	SELECTIONS PAGE B12-7
---------------------------------	-----------------------------	---	--------------------------

DIMENSIONS

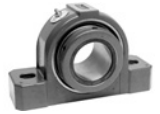

S-2000 Piloted Flange

Bearing	Shaft Size Inch	TRIDENT Seal				Labyrinth Seal			
		Non-Expansion		Expansion		Non-Expansion		Expansion	
		Part No.	Part Name	Part No.	Part Name	Part No.	Part Name	Part No.	Part Name
22208	1-3/8	070644	FC-S2-106R	070671	FC-S2-106RE	070698	FC-S2-106L	070725	FC-S2-106LE
	1-7/16	070645	FC-S2-107R	070672	FC-S2-107RE	070699	FC-S2-107L	070726	FC-S2-107LE
	1-1/2	070646	FC-S2-108R	070673	FC-S2-108RE	070700	FC-S2-108L	070727	FC-S2-108LE
22209	1-11/16	070648	FC-S2-111R	070675	FC-S2-111RE	070702	FC-S2-111L	070729	FC-S2-111LE
	1-3/4	070649	FC-S2-112R	070676	FC-S2-112RE	070703	FC-S2-112L	070730	FC-S2-112LE
22210	1-15/16	070650	FC-S2-115R	070677	FC-S2-115RE	070704	FC-S2-115L	070731	FC-S2-115LE
	2	070651	FC-S2-200R	070678	FC-S2-200RE	070705	FC-S2-200L	070732	FC-S2-200LE
22211	2-3/16	070652	FC-S2-203R	070679	FC-S2-203RE	070706	FC-S2-203L	070733	FC-S2-203LE
22213	2-7/16	070654	FC-S2-207R	070681	FC-S2-207RE	070708	FC-S2-207L	070735	FC-S2-207LE
22215	2-11/16	070656	FC-S2-211R	070683	FC-S2-211RE	070710	FC-S2-211L	070737	FC-S2-211LE
	2-15/16	070657	FC-S2-215R	070684	FC-S2-215RE	070711	FC-S2-215L	070738	FC-S2-215LE
	3	070658	FC-S2-300R	070685	FC-S2-300RE	070712	FC-S2-300L	070739	FC-S2-300LE
22218	3-7/16	070660	FC-S2-307R	070687	FC-S2-307RE	070714	FC-S2-307L	070741	FC-S2-307LE
22220	3-15/16	070662	FC-S2-315R	070689	FC-S2-315RE	070716	FC-S2-315L	070743	FC-S2-315LE
22222	4-7/16 **	070664	FC-S2-407R	070691	FC-S2-407RE	070718	FC-S2-407L	070745	FC-S2-407LE
22226	4-15/16 **	070666	FC-S2-415R	070693	FC-S2-415RE	070720	FC-S2-415L	070747	FC-S2-415LE

Shaft Size	A	B	C	D	DD	E	F Bolt Dia.	G	H	* K	L	M	N	P	Q	X Total Exp.	Y	Z
1-3/8																		
1-7/16	2.53	5.25	1.84	3.09	4.38	0.75	3/8	1.31	0.50	3.63	2.75	3/8-16	2.55	1.22	1.22	3/16	0.020	1.80
1-1/2																		
1-11/16	2.67	6.13	1.91	3.63	5.13	0.88	7/16	1.45	0.50	4.25	3.19	7/16-14	2.72	1.22	1.27	1/4	0.020	2.08
1-3/4																		
1-15/16	2.84	6.38	2.00	3.80	5.38	0.88	7/16	1.59	0.56	4.50	3.44	7/16-14	2.86	1.25	1.27	1/4	0.020	2.30
2																		
2-3/16	2.94	7.13	2.19	4.25	6.00	1.00	1/2	1.56	0.56	5.00	3.75	1/2-13	2.98	1.38	1.42	1/4	0.025	2.59
2-7/16	3.20	7.63	2.50	4.59	6.50	1.00	1/2	1.64	0.63	5.50	4.06	1/2-13	3.20	1.56	1.56	1/4	0.025	2.94
2-11/16																		
2-15/16	3.59	8.75	2.63	5.30	7.50	1.25	5/8	2.03	0.75	6.38	4.70	5/8-11	3.64	1.56	1.63	1/4	0.025	3.47
3																		
3-7/16	4.00	10.25	3.00	6.09	8.63	1.27	3/4	2.36	0.94	7.38	5.50	3/4-10	3.88	1.64	1.52	1/4	0.025	4.05
3-15/16	4.47	10.88	3.50	6.63	9.38	1.47	3/4	2.66	1.13	8.13	6.00	3/4-10	4.56	1-31	1.91	5/16	0.025	4.50
4-7/16	6.53	13.58	4.00	5.88	11.75	1.45	3/4**	3.53	1.00	10.25	6.45	3/4-10	5.50	3.00	1.98	3/8	N/A	N/A
4-15/16	6.91	14.84	4.38	6.38	12.75	1.70	7/8**	3.44	1.25	11.00	7.45	7/8-9	5.86	3.47	2.42	3/8	N/A	N/A

** Housing utilize 6 bolts equally spaced

* +.000/- .002"

FEATURES/BENEFITS PAGE B12-2	SPECIFICATION PAGE B12-4	HOW TO ORDER/NOMENCLATURE PAGE B12-4	SELECTIONS PAGE B12-7
---------------------------------	-----------------------------	---	--------------------------

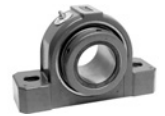

DIMENSIONS

S-2000 Piloted Flange with Type E Dimensions

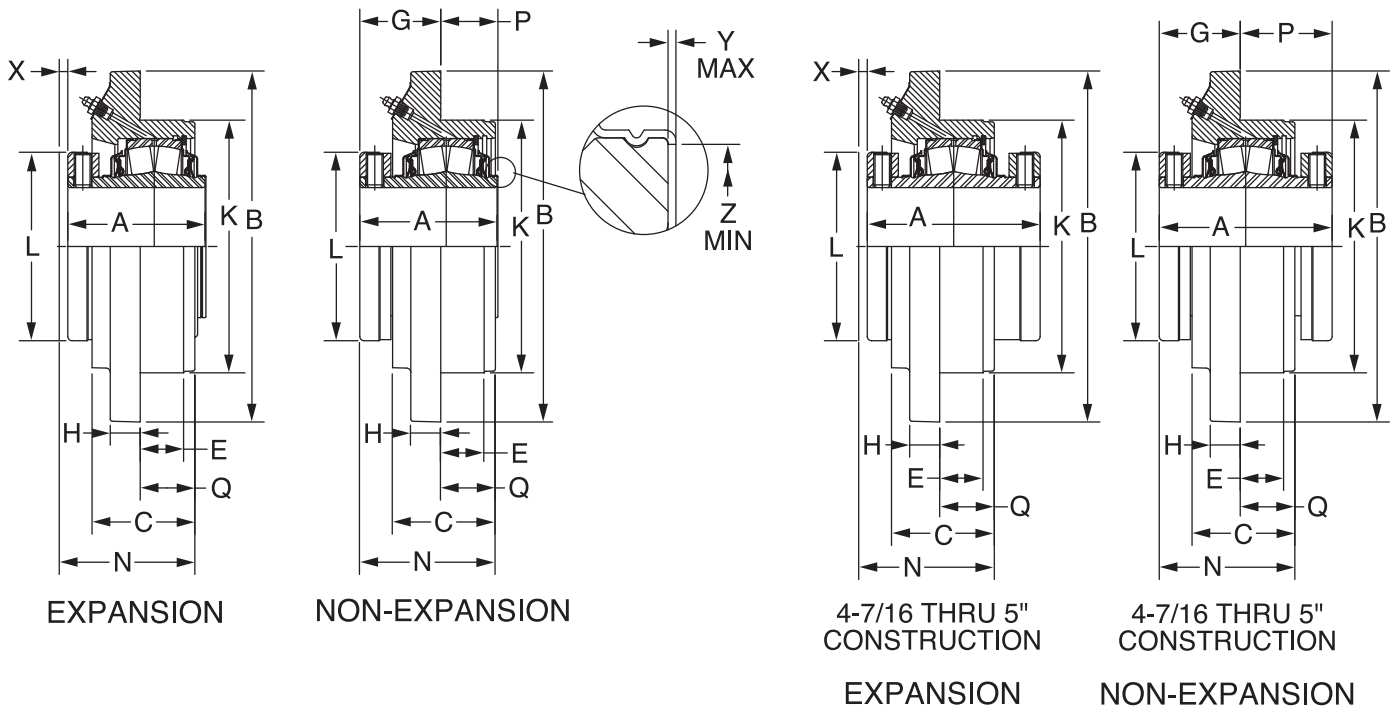
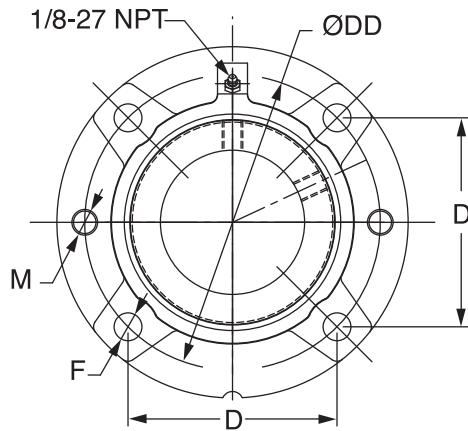



DIMENSIONS

S-2000 Piloted Flange with Type E Dimensions

Bearing Series	Shaft Size*	TRIDENT SEAL				Labyrinth Seal			
		Non Expansion		Expansion		Non Expansion		Expansion	
		Part No.	Part Name	Part No.	Part Name	Part No.	Part Name	Part No.	Part Name
22208	1-3/8	070644	FC-S2-106R	070671	FC-S2-106RE	070698	FC-S2-106L	070725	FC-S2-106LE
	1-7/16	070645	FC-S2-107R	070672	FC-S2-107RE	070699	FC-S2-107L	070726	FC-S2-107LE
22209	1-11/16	070648	FC-S2-111R	070675	FC-S2-111RE	070702	FC-S2-111L	070729	FC-S2-111LE
22210	1-15/16	070650	FC-S2-115R	070677	FC-S2-115RE	070704	FC-S2-115L	070731	FC-S2-115LE
	2	070651	FC-S2-200R	070678	FC-S2-200RE	070705	FC-S2-200L	070732	FC-S2-200LE
22211	2-3/16	070652	FC-S2-203R	070679	FC-S2-203RE	070706	FC-S2-203L	070733	FC-S2-203LE
22213	2-7/16	070654	FC-S2-207R	070681	FC-S2-207RE	070708	FC-S2-207L	070735	FC-S2-207LE
22215	2-11/16	070656	FC-S2-211R	070683	FC-S2-211RE	070710	FC-S2-211L	070737	FC-S2-211LE
	2-15/16	070657	FC-S2-215R	070684	FC-S2-215RE	070711	FC-S2-215L	070738	FC-S2-215LE
	3	070658	FC-S2-300R	070685	FC-S2-300RE	070712	FC-S2-300L	070739	FC-S2-300LE
22218	3-7/16	070660	FC-S2-307R	070687	FC-S2-307RE	070714	FC-S2-307L	070741	FC-S2-307LE
22220	3-15/16	070662	FC-S2-315R	070689	FC-S2-315RE	070716	FC-S2-315L	070743	FC-S2-315LE
22222	4-7/16	071521	EFC-S2-407R	071523	EFC-S2-407RE	071525	EFC-S2-407L	071527	EFC-S2-407LE
22226	4-15/16	071522	EFC-S2-415R	071524	EFC-S2-415RE	071526	EFC-S2-415L	071528	EFC-S2-415LE

Shaft Size	A	B #	C #	D	DD	E #	F Bolt Dia.	G	H #	K ##	L	M	N	P	Q #	X Total Exp.	Y	Z	Set Screw Size	S/S Torque In/Lbs
1-3/8	2.53	5.25	1.84	3.09	4.38	0.75	3/8	1.31	0.50	3.625	2.55	3/8-16	2.53	1.22	1.22	3/16	0.020	1.80	5/16	165
1-7/16	2.67	6.13	1.91	3.63	5.13	0.88	7/16	1.45	0.50	4.250	3.01	7/16-14	2.72	1.22	1.26	1/4	0.020	2.08	5/16	165
1-11/16	2.84	6.38	2.00	3.80	5.38	0.88	7/16	1.59	0.56	4.500	3.44	7/16-14	2.86	1.25	1.26	1/4	0.020	2.30	3/8	290
2-3/16	2.94	7.13	2.19	4.25	6.00	1.00	1/2	1.56	0.56	5.000	3.50	1/2-13	2.98	1.38	1.42	1/4	0.025	2.59	3/8	290
2-7/16	3.20	7.63	2.50	4.59	6.50	1.00	1/2	1.64	0.63	5.500	4.06	1/2-13	3.20	1.56	1.56	1/4	0.025	2.94	3/8	290
2-11/16	3.59	8.75	2.63	5.30	7.50	1.25	5/8	2.03	0.75	6.375	4.61	5/8-11	3.64	1.56	1.63	1/4	0.025	3.47	1/2	620
2-15/16	3.59	8.75	2.63	5.30	7.50	1.25	5/8	2.03	0.75	6.375	4.61	5/8-11	3.64	1.56	1.63	1/4	0.025	3.47	1/2	620
3-7/16	4.01	10.25	3.00	6.09	8.63	1.26	3/4	2.36	0.94	7.375	5.50	3/4-10	3.88	1.65	1.52	1/4	0.025	4.05	1/2	620
3-15/16	4.47	10.88	3.50	6.63	9.38	1.47	3/4	2.66	1.13	8.125	6.00	3/4-10	4.56	1.81	1.91	5/16	0.025	4.50	5/8	1325
4-7/16	6.53	13.50	4.58	5.88	11.75	1.45	3/4 **	3.00	0.94	10.250	6.45	3/4-10	5.63	3.53	2.63	3/8	N/A	N/A	5/8	1325
4-15/16	6.91	14.75	4.88	6.38	12.75	1.70	7/8 **	2.97	1.25	11.000	7.45	7/8-9	5.95	3.94	3.01	3/8	N/A	N/A	5/8	1325

- +0.000 Note(S): "P" And "G" Dimensions Are For Non-Expansion Only
 -0.002 "A" And "P" Dimensions Do Not Include "Y" Dimension

- Reference Dimension Only

FEATURES/BENEFITS PAGE B12-2	SPECIFICATION PAGE B12-4	HOW TO ORDER/NOMENCLATURE PAGE B12-4	SELECTIONS PAGE B12-7
---------------------------------	-----------------------------	---	--------------------------



DIMENSIONS

S-2000 Wide Slot Take-Up 1-3/8 THRU 2-3/16 INCH

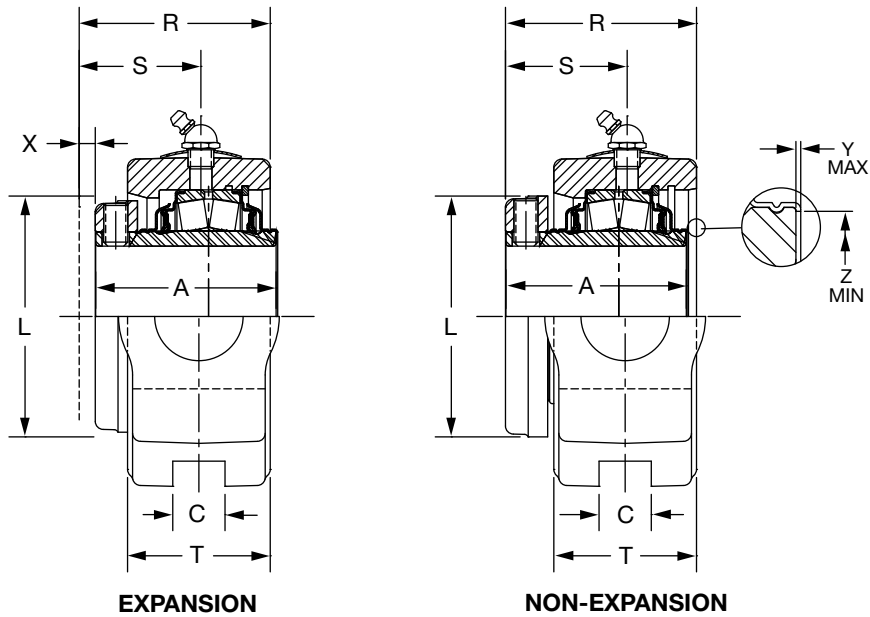
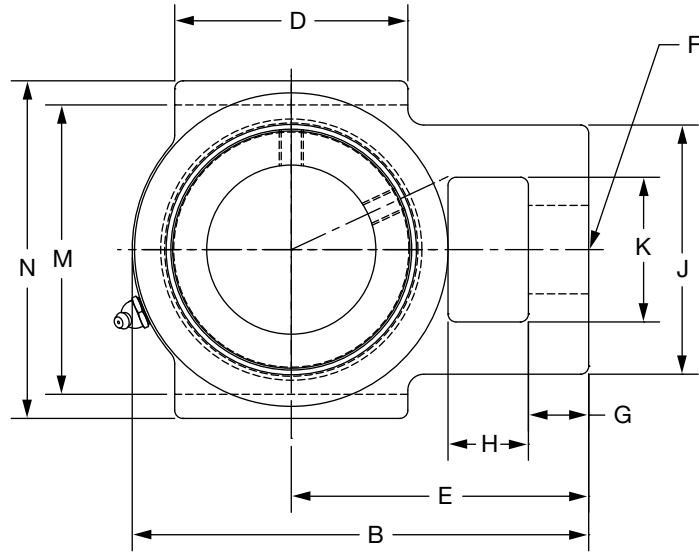

EXPANSION

NON-EXPANSION



DIMENSIONS

S-2000 Wide Slot Take-Up 1-3/8 THRU 2-3/16 INCH

Bearing	Shaft Size Inch	Take-Up Frame	TRIDENT Seal			
			Non-Expansion		Expansion	
			Part No.	Part Name	Part No.	Part Name
22208	1-3/8	CP-308	070752	WSTU-S2-106R	070779	WSTU-S2-106RE
	1-7/16		070753	WSTU-S2-107R	070780	WSTU-S2-107RE
	1-1/2		070754	WSTU-S2-108R	070781	WSTU-S2-108RE
22209	1-11/16	CP-400	070756	WSTU-S2-111R	070783	WSTU-S2-111RE
	1-3/4		070757	WSTU-S2-112R	070784	WSTU-S2-112RE
22210	1-15/16	CP-400	070758	WSTU-S2-115R	070785	WSTU-S2-115RE
	2		070759	WSTU-S2-200R	070786	WSTU-S2-200RE
22211	2-3/16	CP-408	070760	WSTU-S2-203R	070787	WSTU-S2-203RE

Shaft Size	A	B	C	D	E	F	G	H	J	K
1-3/8										
1-7/16	2.53	5.06	0.53	2.75	3.19	7/8	0.69	0.63	2.44	1.44
1-1/2										
1-11/16	2.67	5.94	0.69	3.13	3.81	1-1/8	0.94	0.75	3.31	1.94
1-3/4										
1-15/16	2.84	6.19	0.69	3.63	3.94	1-1/8	0.94	0.75	3.31	1.94
2										
2-3/16	2.94	7.06	0.81	3.63	4.63	1-3/8	0.94	1.25	3.88	2.25

Shaft Size	L	M	N	R	S	T	X Total Exp	Y	Z
1-3/8									
1-7/16	2.75	3.50	4.13	2.73	1.70	2.06	3/16	0.020	1.80
1-1/2									
1-11/16	3.19	4.00	4.75	2.83	1.81	2.03	1/4	0.020	2.08
1-3/4									
1-15/16	3.44	4.00	4.75	2.94	1.94	2.00	1/4	0.020	2.30
2									
2-3/16	3.75	4.50	5.25	3.09	1.98	2.22	1/4	0.020	2.59

FEATURES/BENEFITS PAGE B12-2	SPECIFICATION PAGE B12-4	HOW TO ORDER/NOMENCLATURE PAGE B12-4	SELECTIONS PAGE B12-7
---------------------------------	-----------------------------	---	--------------------------



DIMENSIONS

S-2000 Wide Slot Take-Up 2-7/16 THRU 4-15/16 INCH

Bearing Reference Guide

E-Family Roller Bearings

Specialty Tapered Products

S-2000

UNISPHERE II

IMPERIAL

UNIFIED SAF

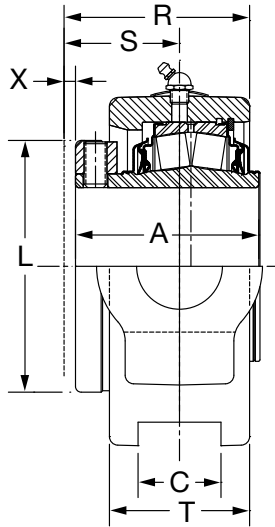
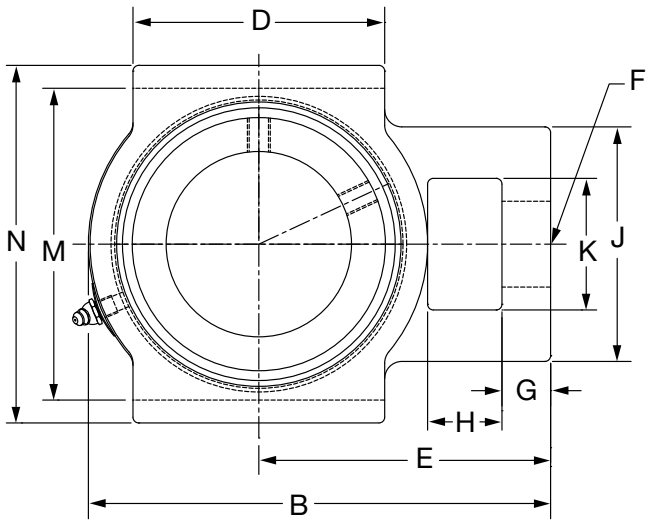

**1-3/8 THRU 3-15/16"
CONSTRUCTION**

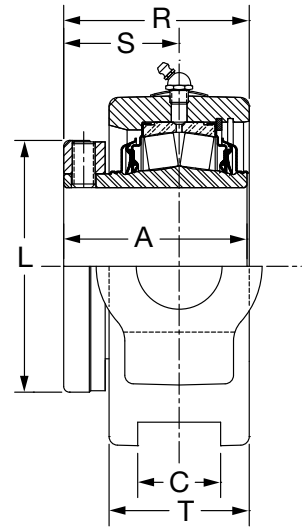

**1-3/8 THRU 3-15/16"
CONSTRUCTION**

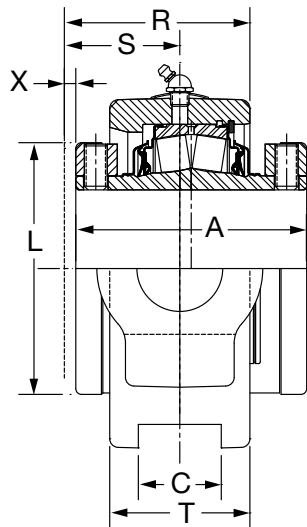

**4-7/16 THRU 4-15/16"
CONSTRUCTION**

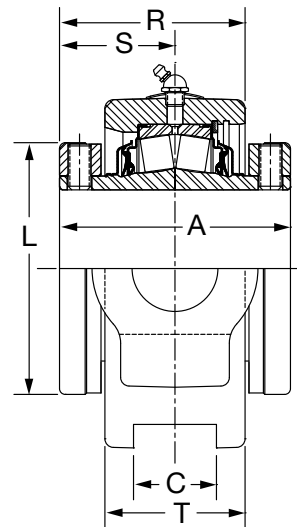

**4-7/16 THRU 4-15/16"
CONSTRUCTION**

FEATURES/BENEFITS
PAGE B12-2

SPECIFICATION
PAGE B12-4

HOW TO ORDER/NOMENCLATURE
PAGE B12-4

SELECTIONS
PAGE B12-7

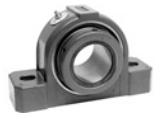

DIMENSIONS

S-2000 Wide Slot Take-Up 2-7/16 THRU 4-15/16 INCH

Bearing	Shaft Size Inch	Take-Up Frame	TRIDENT Seal			
			Non-Expansion		Expansion	
			Part Number	Part Name	Part Number	Part Name
22213	2-7/16	CP-502	070762	WSTU-S2-207R	070789	WSTU-S2-207RE
22215	2-11/16	CP-515	070764	WSTU-S2-211R	070791	WSTU-S2-211RE
	2-15/16		070765	WSTU-S2-215R	070792	WSTU-S2-215RE
	3		070766	WSTU-S2-300R	070793	WSTU-S2-300RE
22218	3-7/16	CP-613	070768	WSTU-S2-307R	070795	WSTU-S2-307RE
22220	3-15/16	CP-810	070770	WSTU-S2-315R	070797	WSTU-S2-315RE
22222	4-7/16	CP-908	070772	WSTU-S2-407R	070799	WSTU-S2-407RE
22226	4-15/16	CP-1004	070774	WSTU-S2-415R	070801	WSTU-S2-415RE

Shaft Size	A	B	C	D	E	F	G	H	J	K
2-7/16	3.20	7.69	1.06	4.38	5.00	1-3/8	1.06	1.25	4.25	2.50
2-11/16	3.59	8.88	1.81	4.50	5.75	1-5/8	1.13	1.50	4.88	2.75
2-15/16										
3	4.00	10.06	1.81	5.50	6.38	1-7/8	1.06	1.63	5.13	2.88
3-7/16										
3-15/16										
4-7/16	6.53	13.38	2.06	7.00	8.75	2-1/8	2.00	2.13	6.78	3.38
4-15/16	6.91	15.63	2.06	9.00	10.31	2-3/8	2.50	2.50	7.00	3.75

Shaft Size	L	M	N	R	S	T	X Total Exp	Y	Z
2-7/16	4.06	5.13	5.88	3.20	2.00	2.44	1/4	0.025	2.94
2-11/16	4.70	5.94	6.69	3.75	2.41	2.69	1/4	0.025	3.47
2-15/16									
3	5.50	6.81	7.81	4.05	2.52	3.06	1/4	0.025	4.05
3-7/16									
3-15/16									
4-7/16	6.45	9.50	10.33	5.34	3.47	3.75	3/8	N/A	N/A
4-15/16	7.45	10.25	11.25	5.73	3.64	4.19	3/8	N/A	N/A

See Page B15-20 for CP Take-Up Frame

FEATURES/BENEFITS PAGE B12-2	SPECIFICATION PAGE B12-4	HOW TO ORDER/NOMENCLATURE PAGE B12-4	SELECTIONS PAGE B12-7
---------------------------------	-----------------------------	---	--------------------------



DIMENSIONS

TPHU Take-Up

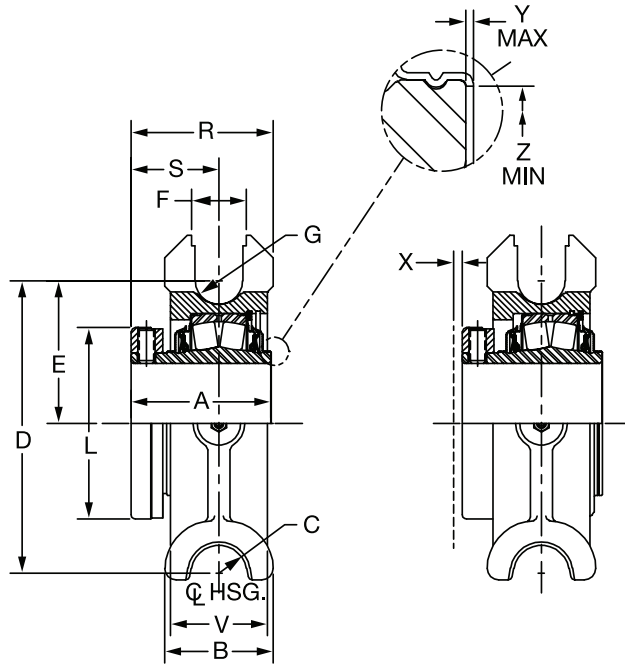
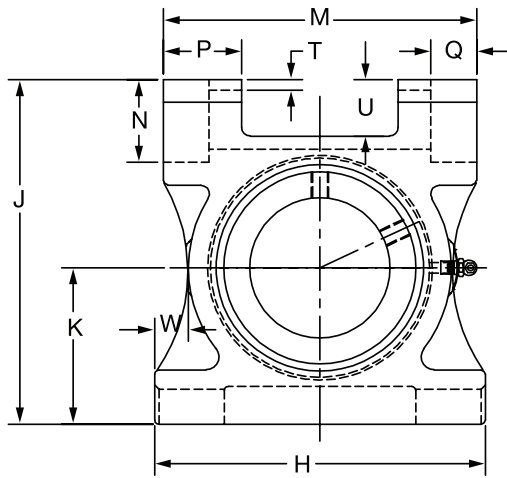

1-3/8" THRU 3-15/16"
CONSTRUCTION
NON-EXPANSION

1-3-8" THRU 3-15/16
CONSTRUCTION
EXPANSION

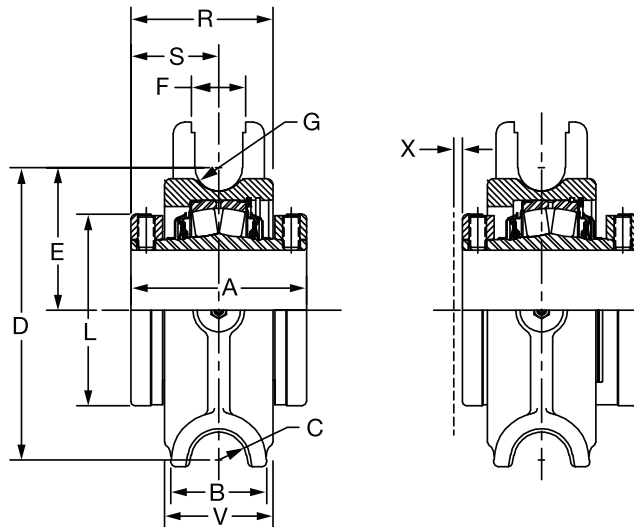

4-7/16" THRU 5"
CONSTRUCTION
NON-EXPANSION

4-7-16" THRU 5"
CONSTRUCTION
EXPANSION

FEATURES/BENEFITS
PAGE B12-2

SPECIFICATION
PAGE B12-4

HOW TO ORDER/NOMENCLATURE
PAGE B12-4

SELECTIONS
PAGE B12-7

DIMENSIONS

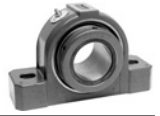

TPHU Take-Up

Bearing Inch	Shaft Size	Take-Up Frame		TRIDENT Seal			
				Non-Expansion		Expansion	
				Part Number	Part Name	Part Number	Part Name
22210	1-15/16 2	TP10	TPHU110	070811	TPHU-S2-115R	070829	TPHU-S2-115RE
				070812	TPHU-S2-200R	070830	TPHU-S2-200RE
22211	2-3/16	TP30	TPHU120	070813	TPHU-S2-203R	070831	TPHU-S2-203RE
22213	2-7/16	TP40	TPHU130	070815	TPHU-S2-207R	070833	TPHU-S2-207RE
22215	2-11/16 2-15/16 3	TP40	TPHU140	070817	TPHU-S2-211R	070835	TPHU-S2-211RE
				070818	TPHU-S2-215R	070836	TPHU-S2-215RE
				070819	TPHU-S2-300R	070837	TPHU-S2-300RE
22218	3-7/16	TP50	TPHU150	070821	TPHU-S2-307R	070839	TPHU-S2-307RE
22220	3-15/16	TP60	TPHU160	070823	TPHU-S2-315R	070841	TPHU-S2-315RE
22222	4-7/16	N/A	TPHU170	070825	TPHU-S2-407R	070843	TPHU-S2-407RE
22226	4-15/16	N/A	TPHU180	070827	TPHU-S2-415R	070845	TPHU-S2-415RE

Shaft Size	A	B	C	D	E	F	G	H	J	K	L	M
1-15/16 2	2.84	2.38	0.81	5.19	2.38	1.06	0.44	6.50	6.44	3.06	3.44	6.00
2-3/16	2.94	2.75	0.81	6.25	3.00	1.44	0.56	7.50	7.63	3.50	3.75	7.00
2-7/16	3.20	2.75	0.81	7.14	3.33	1.44	0.56	8.50	8.28	3.84	4.06	8.00
2-11/16 2-15/16 3	3.59	2.75	0.81	7.13	3.31	1.44	0.56	8.50	8.50	4.00	4.70	8.00
3-7/16	4.00	3.13	0.81	8.41	4.09	1.56	0.69	9.50	10.06	4.50	5.50	9.00
3-15/16	4.47	3.13	0.81	9.25	4.56	1.56	0.69	11.00	11.50	5.50	6.00	10.50
4-7/16	6.53	3.38	0.81	10.19	5.00	1.56	0.69	11.00	12.38	6.00	6.45	10.50
4-15/16	6.91	3.50	0.81	12.44	6.06	1.81	0.69	14.38	14.63	7.19	7.45	13.88

See Page B19-20 Thru B19-25 For TP And TPHU Frames

Shaft Size	N	P	Q	R	S	T	U	V	W	X Total Exp	Y	Z
1-15/16 2	1.66	1.25	0.81	3.19	2.00	0.31	1.06	2.00	0.88	0.25	0.020	2.30
2-3/16	1.94	1.75	1.06	3.39	2.02	0.31	1.56	2.25	0.94	0.25	0.025	2.59
2-7/16	1.88	1.75	1.06	3.53	2.16	0.31	1.44	2.75	1.00	0.25	0.025	2.94
2-11/16 2-15/16 3	1.94	1.75	1.06	3.83	2.45	0.31	1.50	2.75	1.00	0.25	0.025	3.47
3-7/16	2.53	2.25	1.31	4.22	2.66	0.31	1.78	3.13	0.97	0.25	0.025	4.05
3-15/16	2.50	2.31	1.31	4.52	2.95	0.31	2.00	3.13	1.25	0.31	0.025	4.50
4-7/16	2.44	2.31	1.31	5.45	3.45	0.38	1.94	4.00	0.86	0.38	0.036	5.00
4-15/16	2.38	3.94	1.31	5.88	3.66	0.38	1.94	4.45	1.42	0.38	0.036	5.84

See Page B19-20 Thru B19-25 For TP And TPHU Frames

FEATURES/BENEFITS PAGE B12-2	SPECIFICATION PAGE B12-4	HOW TO ORDER/NOMENCLATURE PAGE B12-4	SELECTIONS PAGE B12-7
---------------------------------	-----------------------------	---	--------------------------

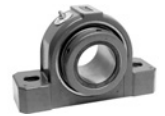

DIMENSIONS

S-2000 Bearing Insert

Bearing Reference Guide

E-Family Roller Bearings

Specialty Tapered Products

S-2000

UNISPHERE II

IMPERIAL

UNIFIED SAF

CONTACT SEAL

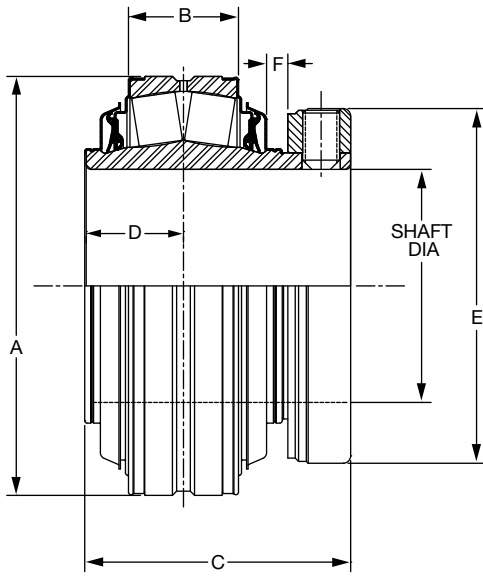

1-3/8 THRU 3-15/16" CONSTRUCTION

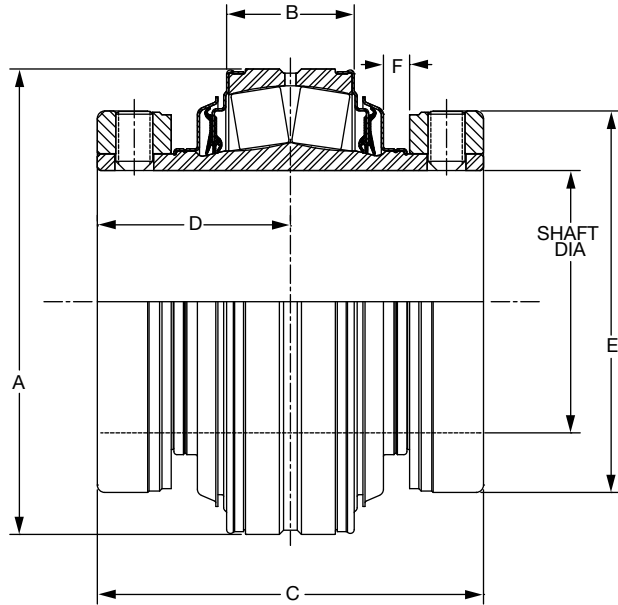

4-7/16 THRU 4-15/16" CONSTRUCTION

LABYRINTH SEAL

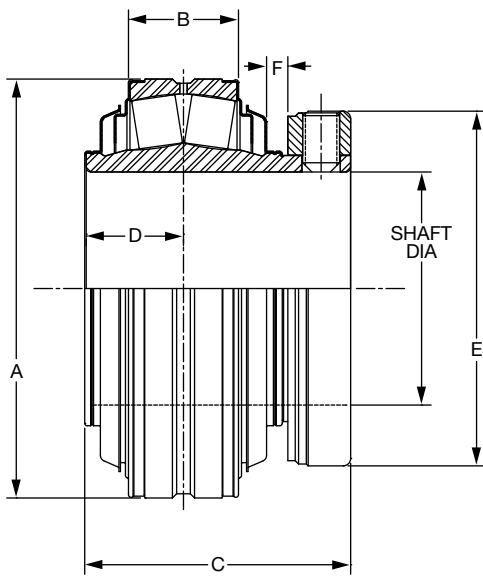

1-3/8 THRU 3-15/16" CONSTRUCTION

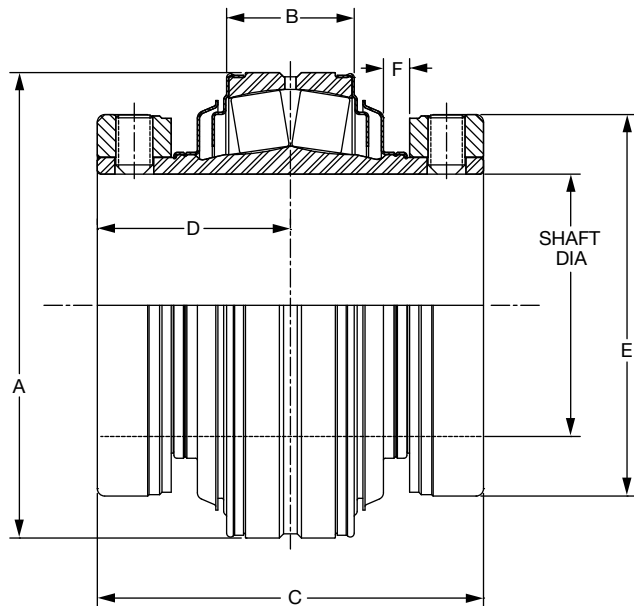

4-7/16 THRU 4-15/16" CONSTRUCTION

FEATURES/BENEFITS PAGE B12-2	SPECIFICATION PAGE B12-4	HOW TO ORDER/NOMENCLATURE PAGE B12-4	SELECTIONS PAGE B12-7
---------------------------------	-----------------------------	---	--------------------------



DIMENSIONS

S-2000 Bearing Insert

Bearing	Shaft Size	TRIDENT Seal		Labyrinth Seal	
		Part Number	Part Name	Part Number	Part Name
22208	1-3/8	070000	INS-S2-106R	070016	INS-S2-106L
	1-7/16	070001	INS-S2-107R	070017	INS-S2-107L
	1-1/2	070002	INS-S2-108R	070018	INS-S2-108L
22209	1-11/16	070003	INS-S2-111R	070019	INS-S2-111L
	1-3/4	070004	INS-S2-112R	070020	INS-S2-112L
22210	1-15/16	070005	INS-S2-115R	070021	INS-S2-115L
	2	070006	INS-S2-200R	070022	INS-S2-200L
22211	2-3/16	070007	INS-S2-203R	070023	INS-S2-203L
22213	2-7/16	070008	INS-S2-207R	070024	INS-S2-207L
22215	2-11/16	070009	INS-S2-211R	070025	INS-S2-211L
	2-15/16	070010	INS-S2-215R	070026	INS-S2-215L
	3	070011	INS-S2-300R	070027	INS-S2-300L
22218	3-7/16	070012	INS-S2-307R	070028	INS-S2-307L
22220	3-15/16	070013	INS-S2-315R	070029	INS-S2-315L
22222	4-7/16	070014	INS-S2-407R	070030	INS-S2-407L
22226	4-15/16	070015	INS-S2-415R	070031	INS-S2-415L

Shaft Size	A	B	C	D	E
1-3/8					
1-7/16	3.15	0.95	2.53	0.97	2.66
1-1/2					
1-11/16	3.35	0.95	2.66	0.95	3.10
1-3/4					
1-15/16	3.54	0.95	2.84	1.00	3.34
2					
2-3/16	3.94	1.05	2.94	1.05	3.66
2-7/16	4.72	1.28	3.20	1.21	3.97
2-11/16					
2-15/16	5.12	1.28	3.59	1.22	4.63
3					
3-7/16	6.30	1.63	4.00	1.48	5.50
3-15/16	7.10	1.88	4.48	1.65	6.00
4-7/16	7.87	2.16	6.53	3.27	6.45
4-15/16	9.10	2.59	6.91	3.45	7.45

FEATURES/BENEFITS PAGE B12-2	SPECIFICATION PAGE B12-4	HOW TO ORDER/NOMENCLATURE PAGE B12-4	SELECTIONS PAGE B12-7
---------------------------------	-----------------------------	---	--------------------------

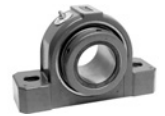

DIMENSIONS

Steel S-2000 Open End Covers



Shaft Size	Front End				Backside			
	S2000 & S2000-HD		E-S2000 & ES2000-HD		S2000 & S2000-HD		E-S2000 & ES2000-HD	
	Dodge Part No.	Description	Dodge Part No.	Description	Dodge Part No.	Description	Dodge Part No.	Description
1-3/8	070240	S2ECO-08-106	070240	S2ECO-08-106	072503	S2IPBECO-08-106	072503	S2IPBECO-08-106
1-7/16	070241	S2ECO-08-107	070241	S2ECO-08-107	072504	S2IPBECO-08-107	072504	S2IPBECO-08-107
1-1/2	070242	S2ECO-08-108	070242	S2ECO-08-108	072505	S2IPBECO-08-108	072506	ES2IPBECO-09-108
1-11/16	070243	S2ECO-09-111	070243	S2ECO-09-111	072508	S2IPBECO-09-111	072508	S2IPBECO-09-111
1-3/4	070244	S2ECO-09-112	070244	S2ECO-09-112	072509	S2IPBECO-09-112	072510	ES2IPBECO-10-112
1-15/16	070245	S2ECO-10-115	070245	S2ECO-10-115	072512	S2IPBECO-10-115	072512	S2IPBECO-10-115
2	070246	S2ECO-10-200	070246	S2ECO-10-200	072513	S2IPBECO-10-200	072513	S2IPBECO-10-200
2-3/16	070247	S2ECO-11-203	070247	S2ECO-11-203	072514	S2IPBECO-11-203	072514	S2IPBECO-11-203
2-7/16	070178	S2IPECO-13-207	070178	S2IPECO-13-207	072518	S2IPBECO-13-207	072518	S2IPBECO-13-207
2-11/16	070248	S2ECO-15-211	070248	S2ECO-15-211	072520	S2IPBECO-15-211	072520	S2IPBECO-15-211
2-15/16	070249	S2ECO-15-215	070249	S2ECO-15-215	072522	S2IPBECO-15-215	072522	S2IPBECO-15-215
3	070250	S2ECO-15-300	070250	S2ECO-15-300	072523	S2IPBECO-15-300	072523	S2IPBECO-15-300
3-7/16	070186	S2IPECO-18-307	070186	S2IPECO-18-307	072526	S2IPBECO-18-307	072526	S2IPBECO-18-307
3-15/16	070189	S2IPECO-20-315	070189	S2IPECO-20-315	072529	S2IPBECO-20-315	072529	S2IPBECO-20-315
4-7/16	070191	S2IPECO-22-407	070191	S2IPECO-22-407	072532	S2BECO-22-407	072532	S2BECO-22-407
4-15/16	070193	S2IPECO-26-415	070193	S2IPECO-26-415	072535	S2BECO-26-415	072535	S2BECO-26-415

DIMENSIONS

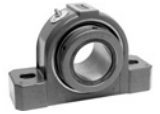

Steel S-2000 Closed End Covers



Shaft Size	S2000 & S2000-HD		E-S2000 & ES2000-HD	
	Dodge Part No.	Description	Dodge Part No.	Description
1-3/8 to 1-1/2	069970	S2EC08	069960	IPEC08
1-11/16 to 1-3/4	069971	S2EC09	069961	IPEC09
1-15/16 to 2	069972	S2EC10	069962	IPEC10
2-3/16	069973	S2EC11	069963	IPEC11
2-7/16	069964	S2EC13	069964	IPEC13
2-11/16 to 3	069975	S2EC15	069965	IPEC15
3-7/16	069966	S2IPEC18	069966	S2IPEC18
3-15/16	069967	S2IPEC20	069967	S2IPEC20
4-7/16	069968	S2IPEC22	069968	S2IPEC22
4-15/16	069969	S2IPEC26	069969	S2IPEC26

Bearing Reference Guide

E-Family Roller Bearings

Specialty Tapered Products

S-2000

UNISPHERE II

IMPERIAL

UNIFIED SAF

FEATURES/BENEFITS PAGE B12-2	SPECIFICATION PAGE B12-4	HOW TO ORDER/NOMENCLATURE PAGE B12-4	SELECTIONS PAGE B12-7
---------------------------------	-----------------------------	---	--------------------------



DIMENSIONS

S2000 End Cover

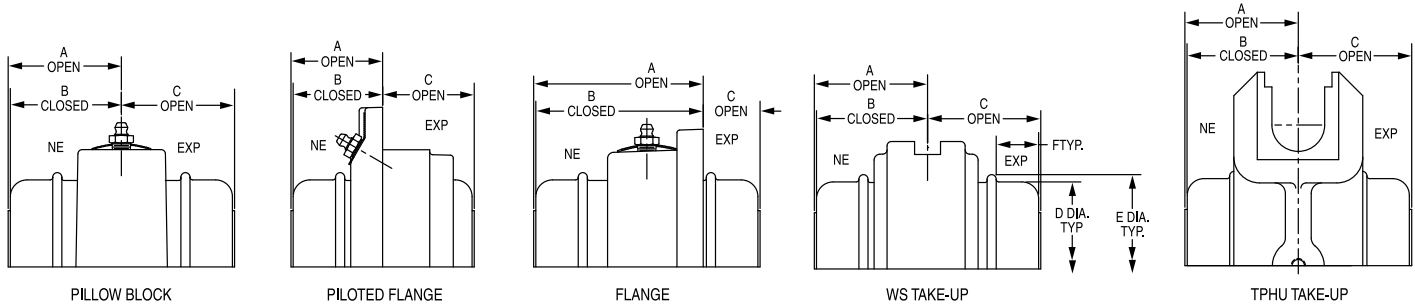

Bearing Reference Guide

E-Family Roller Bearings

Specialty Tapered Products

S-2000

UNISPHERE II

IMPERIAL

UNIFIED SAF

	Shaft Size	S2000 Pillow Block (2-Bolt)	S2000 Pillow Block (4-Bolt)	*E-S2000 Pillow Block (2-Bolt)	*E-S2000 Pillow Block (4-Bolt)	S2000 Piloted Flange	*E-S2000 Piloted Flange	S2000 Round Flange	S2000 Square Flange	*E-S2000 Square Flange	Wide Slot Take-Up	Top Angle Take-Up	D	E	F
A OPEN	1-3/8	2.03		2.03		1.67	1.67	3.12	3.45	3.45	2.06				
B CLOSED	1-7/16	1.97	N/A	1.97	N/A	1.61	1.61	3.06	3.39	3.39	2.00	N/A	2.94	3.19	0.75
C OPEN	1-1/2	2.11		2.11		2.46	2.46	0.99	0.99	1.20	2.10				
A OPEN		2.22		2.22		1.83	1.83	3.33	4.07	4.07	2.19				
B CLOSED	1-11/16	2.16	N/A	2.16	N/A	1.77	1.77	3.27	4.01	4.01	2.13	N/A	3.27	3.39	0.88
C OPEN		2.25		2.25		2.60	2.60	1.10	1.10	1.20	2.25				
A OPEN		2.22		2.22		1.83	1.83	3.33	4.07	4.07	2.19				
B CLOSED	1-3/4	2.16	N/A	2.16	N/A	1.77	1.77	3.27	4.01	4.01	2.13	N/A	3.27	3.39	0.88
C OPEN		2.25		2.25		2.60	2.60	1.10	1.10	1.20	2.25				
A OPEN	1-15/16	2.31	2.31	2.31		1.92	1.92	3.47	3.95	3.95	2.25	2.31			
B CLOSED	THRU	2.25	2.25	2.25	N/A	1.86	1.86	3.41	3.89	3.89	2.19	2.25	3.52	3.61	1.02
C OPEN	2	2.45	2.45	2.45		2.83	2.83	1.28	1.28	1.38	2.45	2.43			
A OPEN		2.47	2.47	2.47		2.00	2.00	3.69	4.53	4.53	2.42	2.47			
B CLOSED	2-3/16	2.41	2.41	2.41	N/A	1.94	1.94	3.63	4.47	4.47	2.36	2.40	3.77	3.95	1.03
C OPEN		2.54	2.54	2.54		3.00	3.00	1.32	1.32	1.40	2.54	2.54			
A OPEN		2.53	2.53	2.53	2.53	2.18	2.18	4.04	4.72	4.72	2.53	2.70			
B CLOSED	2-7/16	2.44	2.44	2.44	2.44	2.09	2.09	3.95	4.63	4.63	2.44	2.61	4.41	4.64	1.00
C OPEN		2.77	2.77	2.77	2.77	3.24	3.24	1.37	1.37	2.77	2.77	2.72			
A OPEN	2-11/16	2.65	2.65	2.65	2.65	2.29	2.29	4.18	5.06	5.06	2.70	2.73			
B CLOSED	2-15/16	2.56	2.56	2.56	2.56	2.20	2.20	4.09	4.97	4.97	2.61	2.64	4.92	5.06	1.22
C OPEN	3	3.06	3.06	3.06	3.06	3.54	3.54	1.66	1.66	1.69	3.06	3.06			
A OPEN		3.07	3.07	3.07	3.07	2.91	2.91		5.78	5.78	3.07	3.07			
B CLOSED	3-7/16	2.94	2.94	2.94	2.94	2.78	2.78	N/A	5.65	5.65	2.94	2.94	5.98	6.22	1.13
C OPEN		3.31	3.31	3.31	3.31	3.59	3.59		1.63	1.66	3.31	3.31			
A OPEN		3.49	3.49		3.49	3.32	3.32		7.17	7.17	3.52	3.61			
B CLOSED	3-15/16	3.36	3.36	N/A	3.36	3.19	3.19	N/A	7.04	7.04	3.39	3.48	6.67	6.91	1.38
C OPEN		3.80	3.80		3.80	4.13	4.13		1.94	1.38	3.80	3.83			
A OPEN			3.96		3.91	4.02	3.85			7.62	3.97	3.96			
B CLOSED	4-7/16	N/A	3.83	N/A	3.78	3.89	3.72	N/A	N/A	7.49	3.84	3.83	7.31	7.56	1.67
C OPEN			4.23		4.23	4.16	4.68			2.06	4.23	4.23			
A OPEN			4.49		4.46	4.24	4.08				4.49	4.49			
B CLOSED	5	N/A	4.36	N/A	4.33	4.11	3.95	N/A	N/A	N/A	4.36	4.36	8.44	8.69	1.91
C OPEN			4.69		4.69	4.91	5.37				4.69	4.68			

FEATURES/BENEFITS PAGE B12-2	SPECIFICATION PAGE B12-4	HOW TO ORDER/NOMENCLATURE PAGE B12-4	SELECTIONS PAGE B12-7
---------------------------------	-----------------------------	---	--------------------------