

Description

The Renesas WP15WBD-RK Evaluation Kit demonstrates 15W wireless power transfer and bi-directional data communication between a transmitter (Tx) board with the Renesas P9242-R3 Wireless Power Transmitter IC and a receiver (Rx) board with the Renesas P9221-R3 Wireless Power Receiver IC. The bi-directional data communication channel enables users to authenticate a wirelessly charged receiver device with a specific charging transmitter base or to transfer system data without any additional hardware.

This evaluation kit adds bi-directional communication to Renesas' standard, WPC 1.2-compliant, 15W transmitter P9242-R and receiver P9221-R evaluation kits without compromising any existing features. Its main contents are the transmitter P9242-R3-EVK Evaluation Board and the receiver P9221-R3-EVK Evaluation Board.

In customer end systems, the transmitter and receiver boards need to have external microcontrollers (MCU) to orchestrate the bi-directional communication. The MCU on the receiver board loads data into the user outgoing data registers and triggers the communication by writing to the *Command* register. The transmitter receives the data and interrupts the external MCU on the transmitter pad. The transmitter follows the same procedure to send the data to the receiver. There are no external MCU's on the P9242-R3-EVK and P9221-R3-EVK Evaluation Boards. Instead, *IDT I2C Lite*, an intuitive I2C-based graphical user interface (GUI), and two USB-to-I2C dongles are used to emulate external MCUs. The USB-to-I2C dongles are included in the kit. The latest version of the *IDT I2C Lite* software is available on the IDT webpage.

This manual focuses on demonstrating the bi-directional data communication features of the P9242-R3 and P9221-R3. The P9242-R3-EVK and P9221-R3-EVK offer the flexibility to program parameters such as the over-current limit and foreign-object detection (FOD) limits by changing resistors. Refer to the user manuals for the P9242-R-EVK Transmitter Evaluation Board and P9221-R-EVK Receiver Evaluation Board for more details related to programming parameters.

Features

- Supports bi-directional data communication
- Enables device authentication and system data transfer
- Up to 15W of power transfer
- 87% end-to-end efficiency
- Flexibility to program parameters
- Intuitive *IDT I2C Lite* GUI
- Base kit is WPC-1.2-compliant

Kit Contents

- P9242-R3-EVK V 2.1 Transmitter Evaluation Board
- P9221-R3-EVK V2.2 Receiver Evaluation Board
- Two USB-to-I2C Dongles
- Adapter: 12V/2A AC

Additional Support

This flexible, turn-key reference design is supported by online design resources to significantly expedite the design-in effort and enable rapid prototyping:

- Schematics
- Allegro® layout files

System Block Diagram

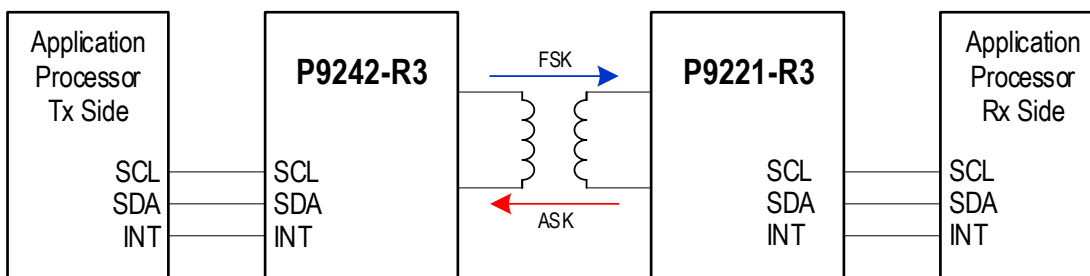

* Allegro® is a trademark of Cadence Systems.

Important Notes

Disclaimer

Integrated Device Technology, Inc. and its affiliated companies (herein referred to as "IDT") shall not be liable for any damages arising out of defects resulting from

- (i) delivered hardware or software
- (ii) non-observance of instructions contained in this manual and in any other documentation provided to user, or
- (iii) misuse, abuse, use under abnormal conditions, or alteration by anyone other than IDT.

TO THE EXTENT PERMITTED BY LAW, IDT HEREBY EXPRESSLY DISCLAIMS AND USER EXPRESSLY WAIVES ANY AND ALL WARRANTIES, WHETHER EXPRESS, IMPLIED, OR STATUTORY, INCLUDING, WITHOUT LIMITATION, IMPLIED WARRANTIES OF MERCHANTABILITY AND OF FITNESS FOR A PARTICULAR PURPOSE, STATUTORY WARRANTY OF NON-INFRINGEMENT, AND ANY OTHER WARRANTY THAT MAY ARISE BY REASON OF USAGE OF TRADE, CUSTOM, OR COURSE OF DEALING.

Restrictions in Use

Renesas' WP15WBD-RK Evaluation Kit is designed for evaluation purposes only. It must not be used for module production or production test setups.

Contents

1. Setup	4
1.1 Required or Recommended User Equipment.....	4
1.2 Required Software on Computer	4
1.2.1 Software Installation	4
1.3 Kit Hardware Connections.....	5
2. Usage Guide.....	7
2.1 Overview of the P9221-R3-EVK	7
2.2 Overview of the P9242-R3-EVK	8
3. Evaluating Bi Directional Data Communication	10
3.1 Transferring Data from the Receiver to the Transmitter	10
3.2 Transferring Data from the Transmitter to the Receiver	12
4. Schematics, Bill of Materials (BOM), and Board Layout.....	13
4.1 P9221-R3-EVK Evaluation Board Schematics V2.2.....	13
4.2 P9242-R3-EVK Evaluation Board Schematics V2.1.....	14
5. Bill of Materials (BOM).....	15
6. Partner Products Information.....	19
6.1 Evaluation Kits.....	19
6.2 Transmitter Coils	19
6.3 Receiver Coils	20
7. Ordering Information.....	20
8. Revision History.....	20

List of Figures

Figure 1. Windows Device Manager Display for Troubleshooting the USB Connection.....	4
Figure 2. Evaluation Kit Connections using the P9242-R3 Transmitter Evaluation Board and the P9221-R3 Receiver Evaluation Board.....	5
Figure 3. I2C Header Connection to the P9221-R3-EVK Receiver Board.....	6
Figure 4. I2C Header Connection to the P9242-R3-EVK Transmitter Board.....	6
Figure 5. I2C Dongle Header.....	6
Figure 6. P9221-R3 V2.2 Evaluation Board Features.....	7
Figure 7. P9242-R3 V2.1 Evaluation Board Features.....	8
Figure 8. P9242-R3 V2.1 Evaluation Board Details.....	9
Figure 9. <i>IDT I2C Lite</i> Software Overview	10

List of Tables

Table 1. P9221-R3-EVK BOM V2.2	15
Table 2. P9242-R3-EVK BOM V2.1	16
Table 3. Recommended Transmitter Coil Manufactures	19
Table 4. Recommended Receiver Coil Manufacturers.....	20

1. Setup

1.1 Required or Recommended User Equipment

The following additional lab equipment is required for using the kit:

- Computer with the Windows® 7 or Windows® 10 operating system.
Note: An optional second computer can expedite the evaluation. For this option, a second USB-to-I2C dongle is provided in the kit. In this case, repeat the setup procedures in section 1.2 for the second computer using the second dongle.
- Oscilloscope
- Multimeter
- Power cables

1.2 Required Software on Computer

Visit the WP15WBD-RK website at www.IDT.com/WP15WBD-RK, and download latest version of the *IDT I2C Lite* software, script files, and USB drivers from the IDT website. The software provides an intuitive graphical user interface for sending I2C commands using the USB-to-I2C dongle shipped with the Evaluation Kit.

1.2.1 Software Installation

Follow these procedures to install the software:

1. Do not connect the USB-to-I2C dongle before installing the software.
2. Run the downloaded *USB Drivers Setup* executable file and follow the user prompts to install the USB drivers.
3. After finishing the setup of the USB drivers, connect one of the USB-to-I2C dongles to the USB port. Wait for a few moments to let Windows® map the drivers for the dongle.
4. Open the Device Manager from the Windows control panel and check the devices listed under “Universal Serial Bus controllers” section. “FT4222H Interface A” and “FT4222H Interface B” should appear in this section as shown in Figure 1.
5. Run the *IDT I2C Lite Setup* file and follow the user prompts to install the *IDT I2C Lite* software.
6. Place the downloaded script files in the *C:\Users\...\AppData\Roaming\IDT I2C Lite* folder to expedite loading the script files into the *IDT I2C Lite* software. These scripts contain a series of I2C commands to send and receive data on the receiver and transmitter.

Figure 1. Windows Device Manager Display for Troubleshooting the USB Connection

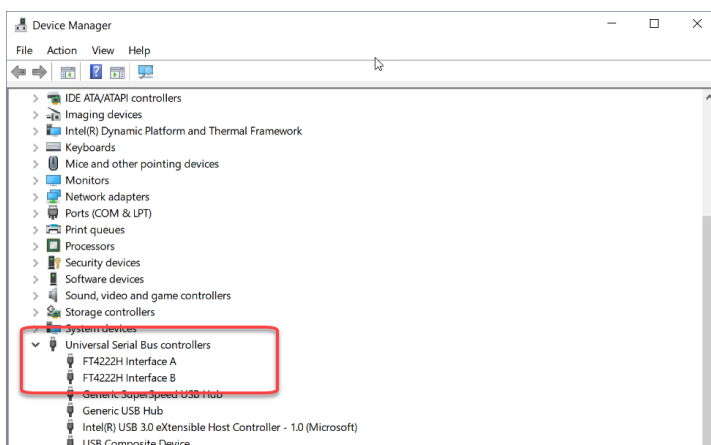

1.3 Kit Hardware Connections

Follow these procedures to set up the kit as shown in Figure 2.

1. Plug the 12V adapter or user's power supply into the J3 barrel connector on the bottom of the P9242-R3-EVK board (see Figure 7).
2. Place the P9221-R3-EVK on the transmitter (TX) pad with the components facing up as shown in Figure 2.
3. Verify that the two green LEDs identified in Figure 2 are illuminated indicating that coupling has been established.
4. Connect wires to the VOUT and GND test points on the P9221-R3-EVK receiver to measure the output voltage (see Figure 6) and apply a load requiring less than the programmed current limit.
5. Connect the USB-to-I2C dongle to the computer's USB port. If using a second computer, connect the second dongle to its USB port.
6. To send I2C commands to the P9221-R3-EVK, connect the I2C header on one of the connected dongles to J1 on the P9221-R3-EVK as shown in Figure 3. The black wire on the dongle should be on the GND pin of the J1 Header. See sections 3.1 and 3.2 for detailed instructions.
7. To send I2C commands to the P9242-R3-EVK, connect the I2C header on one of the connected dongles to J2 on the P9242-R3-EVK as shown in Figure 4. The black wire on the dongle should be on the GND pin of the J2 header. See sections 3.1 and 3.2 for detailed instructions.

Figure 2. Evaluation Kit Connections using the P9242-R3 Transmitter Evaluation Board and the P9221-R3 Receiver Evaluation Board

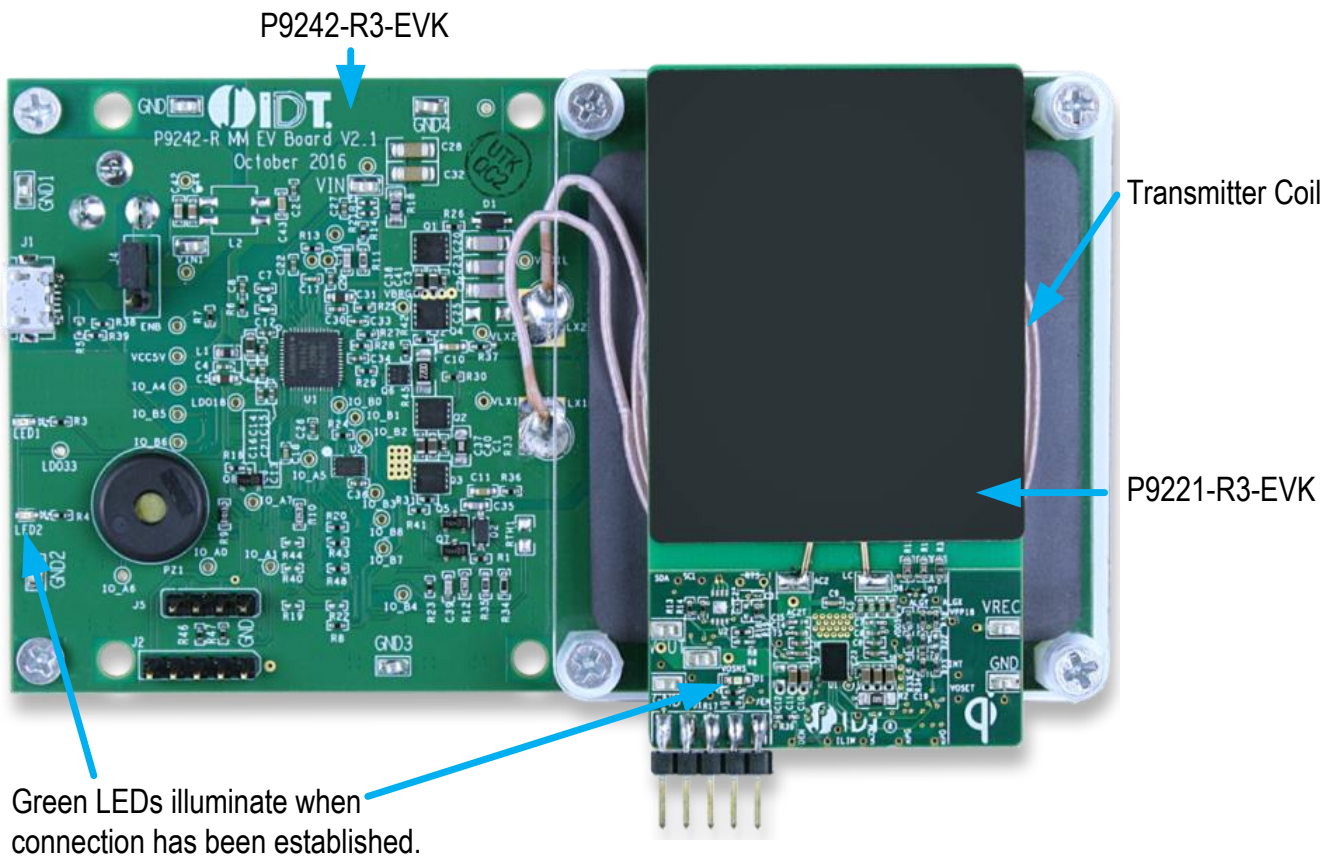

Note: The buzzer shown on the P9242-R3-EVK is not placed for this kit.

Figure 3. I2C Header Connection to the P9221-R3-EVK Receiver Board

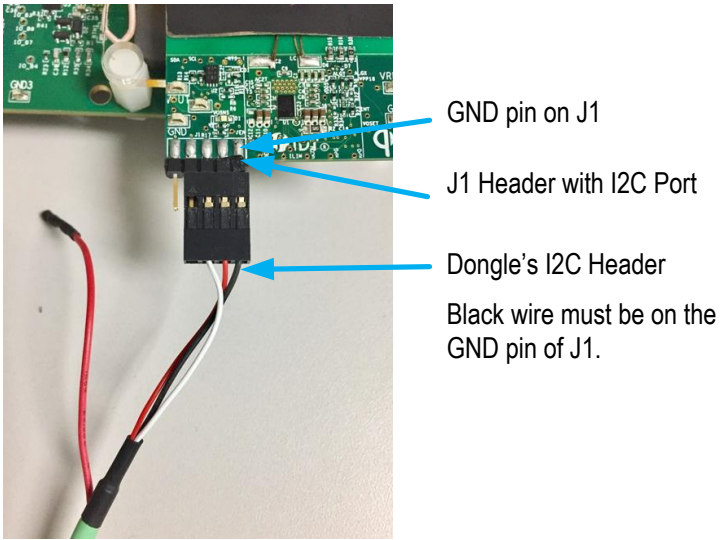

Figure 4. I2C Header Connection to the P9242-R3-EVK Transmitter Board

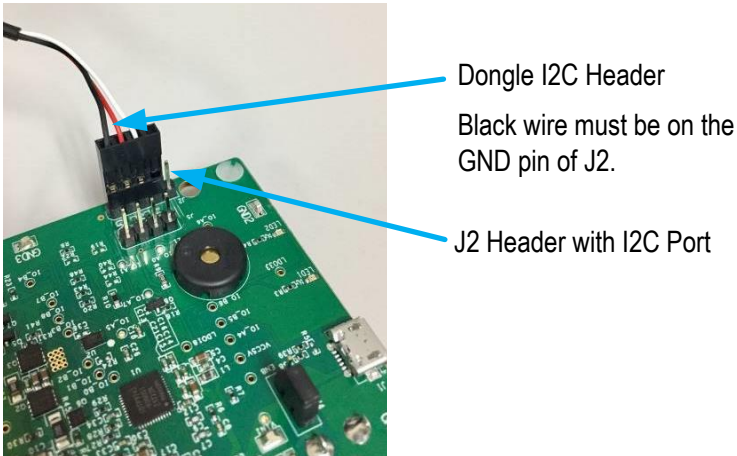
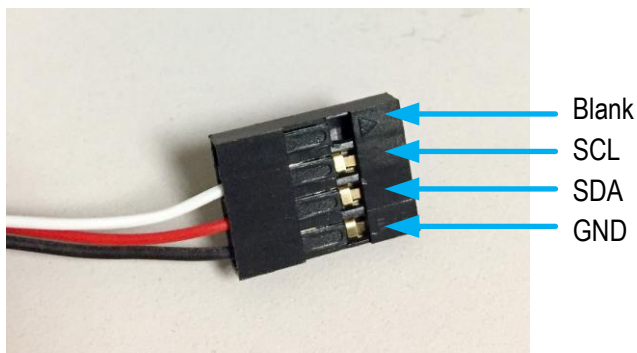

Figure 5. I2C Dongle Header



2. Usage Guide

2.1 Overview of the P9221-R3-EVK

Figure 6. P9221-R3 V2.2 Evaluation Board Features

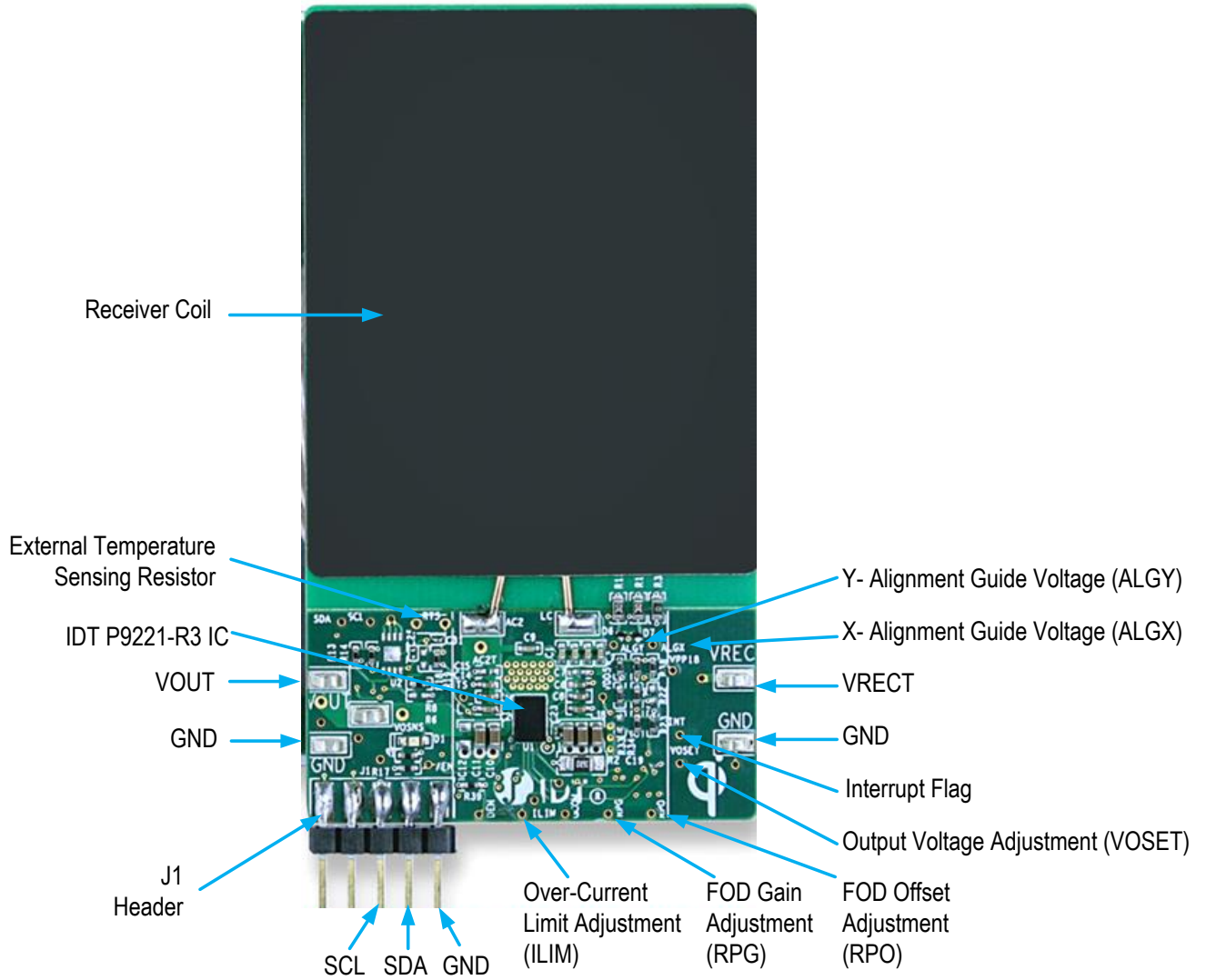

2.2 Overview of the P9242-R3-EVK

Figure 7. P9242-R3 V2.1 Evaluation Board Features

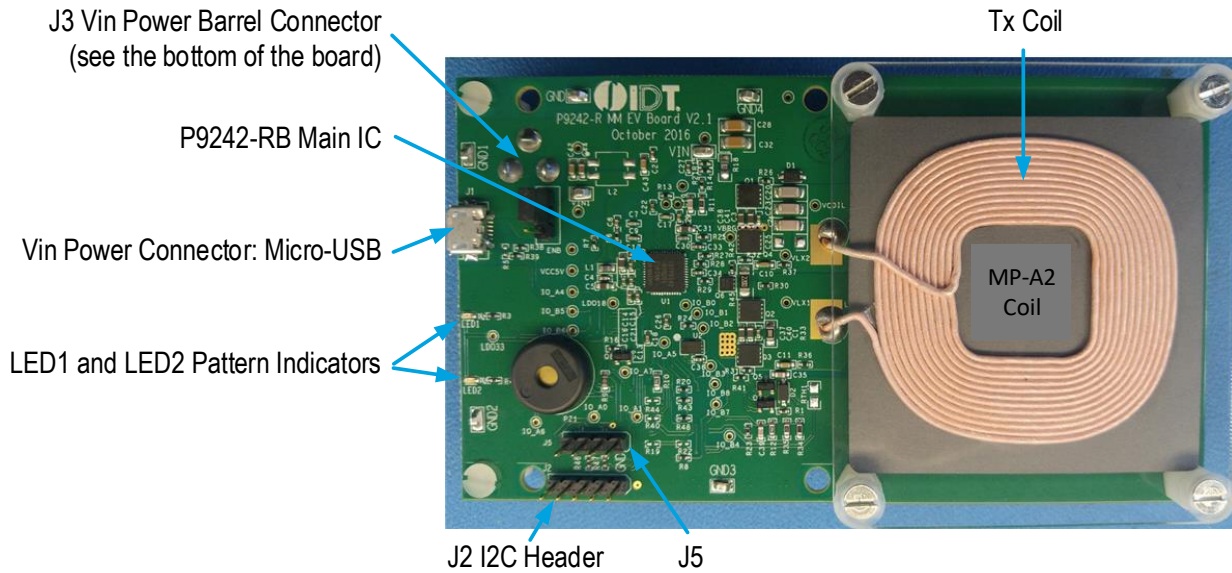

Note: The P9242-RB IC is used on the P9242-R3 V2.1 Evaluation board instead of the P9242-R3 IC. The P9242-R3 has bi-directional communication firmware pre-programmed into its one-time programmable memory and does not allow the firmware to be customized. The P9242-RB offers a pre-programmed bootloader that must be used in conjunction with an external flash. Bidirectional communications firmware is loaded into the external flash. The firmware can be customized in external flash. There is no functionality difference between the P9242-R3 V2.1 Evaluation board with P9242-R3 IC and the P9242-RB with external flash.

Figure 8. P9242-R3 V2.1 Evaluation Board Details

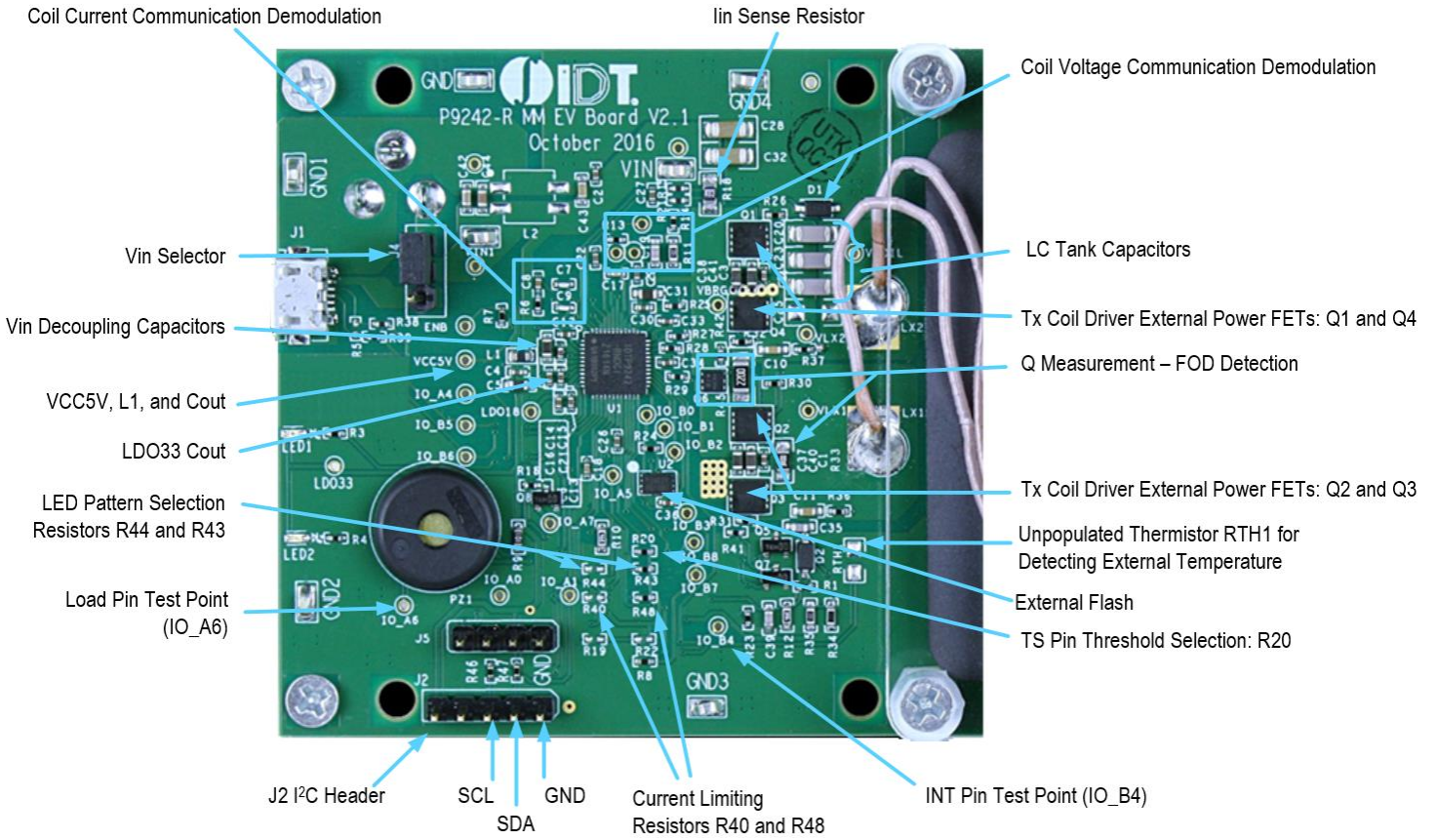

3. Evaluating Bi Directional Data Communication

3.1 Transferring Data from the Receiver to the Transmitter

To send the data from the P9221-R3 to the P9242-R3, the external microcontroller (MCU) on the receiver loads data into the user outgoing data registers of the P9221-R3 and triggers the communication by writing to the *Command* register of the P9221-R3 via the I2C bus. The P9242-R3 receives the data and interrupts the external MCU on the transmitter pad. The external MCU on the transmitter pad reads the user incoming data registers via the I2C bus after it receives the interrupt. More details on the data transfer algorithm are in the P9221-R3 and P9242-R3 datasheets.

There are no external MCUs on the receiver and transmitter evaluation boards in the WP15WBD-RD Evaluation Kit. Instead the *IDT I2C Lite* software and USB-to-I2C dongles are used to simulate an external MCU. The USB-to-I2C dongle does not have the capability to generate interrupts for the *IDT I2C Lite* software, so it is necessary to poll the *Status* register to check for incoming data or probe the \overline{INT} test point on the P9242-R3-EVK (IO_B4 test point) using an oscilloscope.

Follow these procedures to transfer the data from the receiver board to the transmitter board:

1. Power up the transmitter and receiver evaluation boards by following the steps in section 1.3.
2. Verify that the green LEDs (identified in Figure 2) on both the transmitter and receiver boards are illuminated indicating that devices are in the power transfer phase. Bi-directional communication is enabled only when the devices are in the power transfer phase.
3. Connect the USB-to-I2C dongle to the computer's USB port and connect the I2C header of the dongle to J1 on the P9221-R3-EVK board as shown in Figure 3. The black wire on the dongle should be on the GND pin of the J1 header.
4. Open the *IDT I2C Lite* GUI by going to the Windows start menu: IDT GUI Application → IDT I2C Lite. Figure 9 shows an overview.

Figure 9. IDT I2C Lite Software Overview

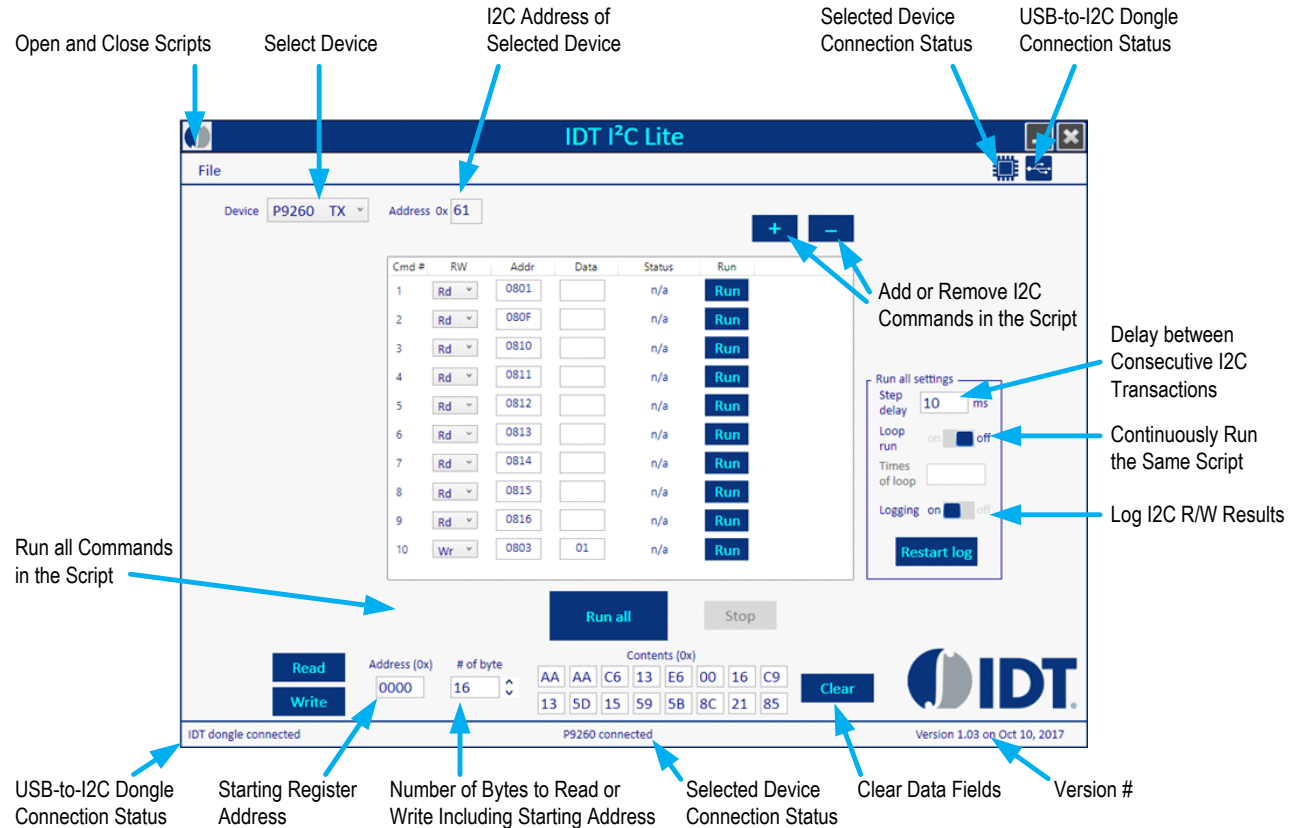

5. Verify the proper USB dongle connection by checking the USB icon status in the top right corner of the GUI. When the USB dongle is properly connected, the USB icon should be bright blue and the bottom left corner should indicate "IDT dongle connected."
6. Select "P9221 RX" from the "Device" drop-down menu in the GUI.
7. Verify that the proper P9221-R3-EVK connection is recognized by the GUI by checking the device icon in the top right corner of the GUI. When the P9221-R3-EVK is properly connected, the selected device icon should be bright blue and the message in the middle of the bottom status bar in the GUI should indicate "P9221 connected."
8. Click "Open Script" from the "File" menu in the top left corner of the GUI, and navigate to the "Send 8 bytes from Rx to Tx" script. This script has all the I2C commands required to send the data from the P9221-R3 to the P9242-R3. The script can be customized by using the "+" and "-" buttons in the GUI.
9. Click the "Run all" button to run all the I2C commands in the script to send the data from the P9221-R3 to the P9242-R3.
10. If using only one computer, gently disconnect the dongle I2C header from the receiver board, and connect the I2C header to J2 of the P9242-R3-EVK transmitter board as shown in Figure 4. The black wire on the dongle should be on the GND pin on the J2 header.
If using two computers, follow the subsequent steps on the second computer to read the data.
11. Select "P9242 TX" from the "Device" drop down menu in the GUI.
12. Verify the proper P9242-R3-EVK connection to GUI by checking the selected device icon in the top right corner of the GUI. When the P9242-R3-EVK is properly connected, the icon should be in bright blue color and the bottom status bar in the GUI should indicate "P9242 connected."
13. Click "Open Script" from the "File" menu in the top left corner of the GUI, and navigate to the "Read 8 bytes of data on Tx" script. This script has all the I2C commands required to read data coming into the P9242-R3. The script can be customized by using the "+" and "-" buttons in the GUI.
14. Click the "Run all" button to run all the I2C commands in the script to read the incoming data in the P9242-R3.
15. Verify that the incoming data on the P9242-R3 matches the P9221-R3 outgoing data.

3.2 Transferring Data from the Transmitter to the Receiver

To send the data from the P9242-R3 to the P9221-R3, the external microcontroller (MCU) on the transmitter loads data into the user outgoing data registers of the P9242-R3 and triggers the communication by writing to the *Command* register of the P242-R3 via the I2C bus. The P9221-R3 receives the data and interrupts the external MCU on the receiver board. The external MCU on the receiver board reads the user incoming data registers via the I2C bus after it receives the interrupt. More details on the data transfer algorithm are in the P9221-R3 and P9242-R3 datasheets.

There are no external MCU's on the receiver and transmitter evaluation boards in the WP15WBD-RD Evaluation Kit. Instead, the *IDT I2C Lite* software and USB-to-I2C dongle are used to simulate an external MCU. The USB-to-I2C dongle does not have the capability to generate interrupts for the *IDT I2C Lite* software, so it is necessary to poll the *Data Received Status* register to check for incoming data or probe the interrupt pin on the P9221-R3 (pin 2 on the J1 header on the P9221-R3-EVK board) using an oscilloscope.

Follow these procedures to transfer the data from the transmitter board to the receiver board:

1. Power up the transmitter and receiver evaluation boards by following the steps in section 1.3.
2. Verify that the green LEDs (identified in Figure 2) on both transmitter and receiver boards are illuminated indicating that devices are in the power transfer phase. Bi-directional communication is enabled only when the devices are in the power transfer phase.
3. Connect the USB-to-I2C dongle to the computer's USB port and connect the I2C header of the dongle to J2 on the P9242-R3-EVK board as shown in Figure 4. The black wire on the dongle should be on the GND pin of the J2 header.
4. Open the *IDT I2C Lite* GUI by going to the Windows start menu: IDT GUI Application → IDT I2C Lite. See Figure 9.
5. Verify the proper USB dongle connection by checking the USB icon status in the top right corner of the GUI. When the USB dongle is properly connected, the USB icon should be bright blue and the bottom left corner should indicate "IDT dongle connected."
6. Select "P9242 TX" from the "Device" drop-down menu in the GUI.
7. Verify that the proper P9242-R3-EVK connection is recognized by the GUI by checking the selected device icon in the top right corner of the GUI. When the P9242-R3-EVK evaluation board is properly connected, the icon should be bright blue and the message in the middle of the bottom status bar in the GUI should indicate "P9242 connected."
8. Click "Open Script" from the "File" menu in the top left corner of the GUI, and navigate to the "Send 2 bytes from Tx to Rx" script. This script has all the I2C commands required to send the data from the P9242-R3 to the P9221-R3. The script can be customized by using the "+" and "-" buttons in the GUI.
9. Click the "Run all" button to run all the I2C commands in the script to send the data from the P9242-R3 to the P9221-R3.
10. If using only one computer, gently disconnect the dongle I2C header from the transmitter board, and connect the I2C header to J1 on the P9221-R3-EVK receiver board as shown in Figure 3. The black wire on the dongle should be on the GND pin of the J1 header.
If using two computers, follow the subsequent steps on the second computer to read the data.
11. Select "P9221 RX" from the "Device" drop-down menu in the GUI.
12. Verify the proper P9221-R3-EVK connection to the GUI by checking the selected device icon in the top right corner of the GUI. When the P9221-R3-EVK evaluation board is properly connected, the icon should be bright blue and the bottom status bar in the GUI should indicate "P9221 connected."
13. Click "Open Script" from the "File" menu in the top left corner of the GUI, and navigate to the "Read 2 bytes of data on Rx" script. This script has all the I2C commands required to read data coming into the P9221-R3. The script can be customized by using the "+" and "-" buttons in the GUI.
14. Click the "Run all" button to run all the I2C commands in the script to read the data coming into the P9221-R3.
15. Verify that the incoming data on the P9221-R3 matches the P9242-R3 outgoing data.

4. Schematics, Bill of Materials (BOM), and Board Layout

4.1 P9221-R3-EVK Evaluation Board Schematics V2.2

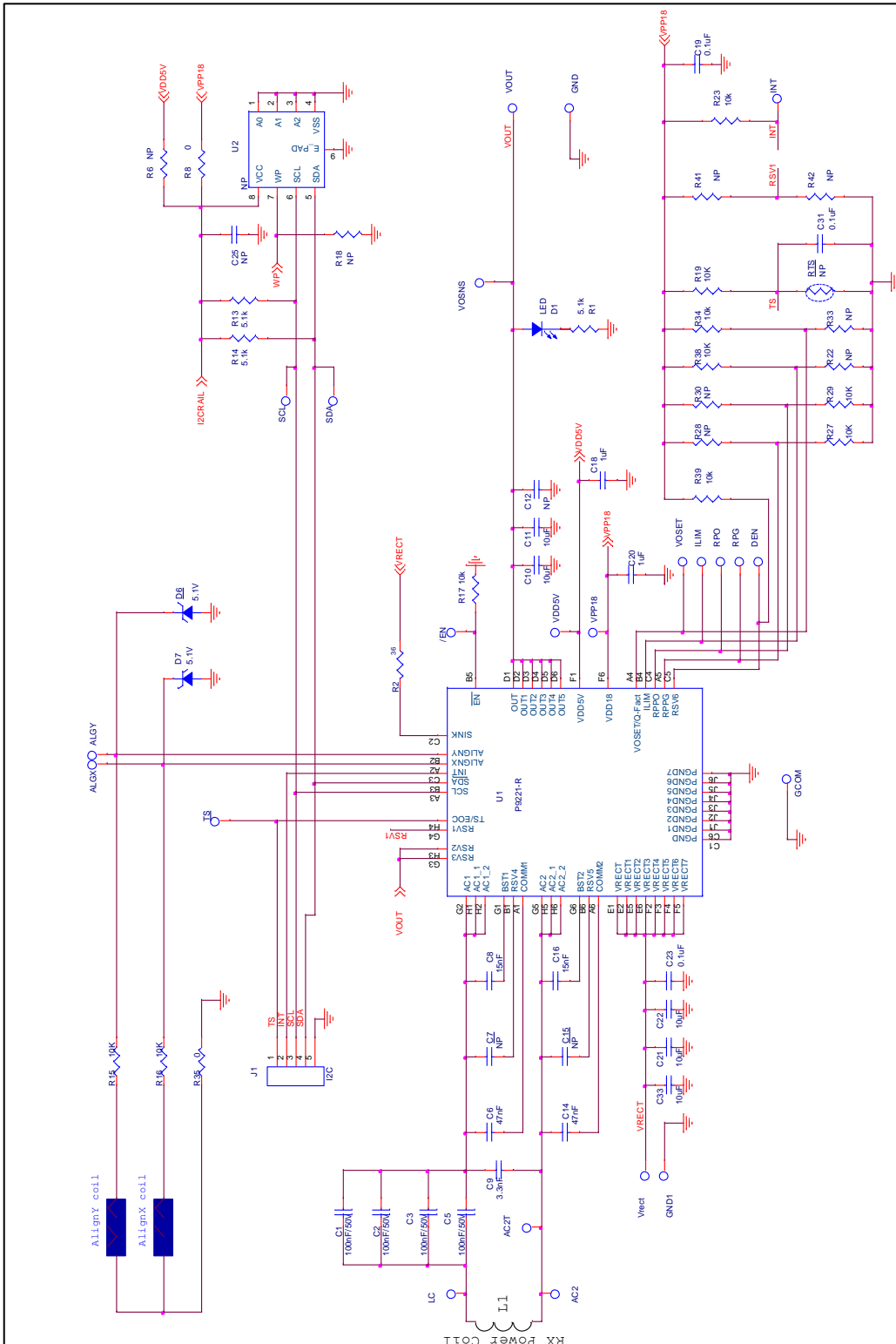

4.2 P9242-R3-EVK Evaluation Board Schematics V2.1

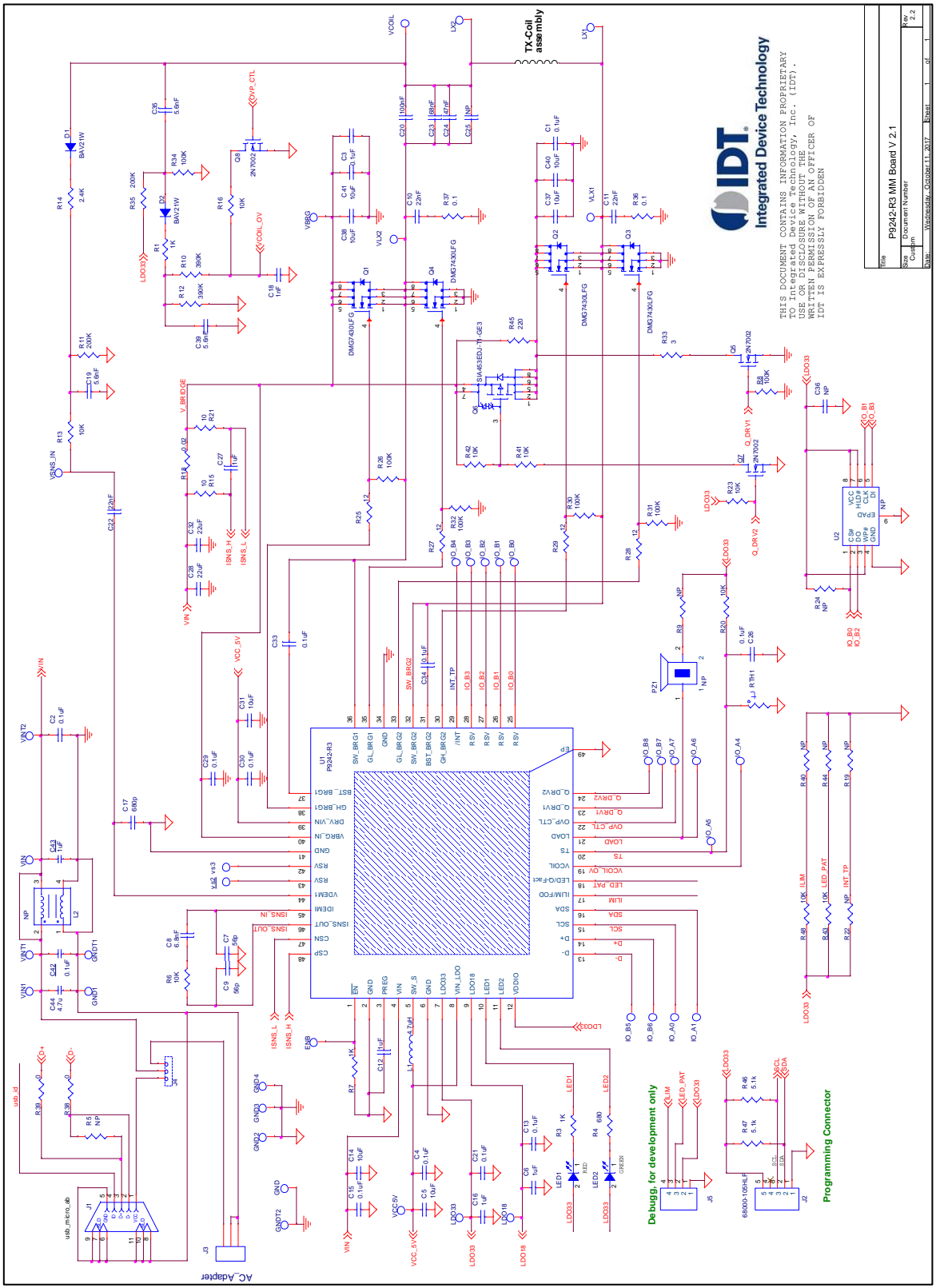

IDT
Integrated Device Technology

THIS DOCUMENT CONTAINS INFORMATION PROPRIETARY TO INTEGRATED DEVICE TECHNOLOGY, INC. (IDT). WRITTEN PERMISSION OF AN OFFICER OF IDT IS EXPRESSLY FORBIDDEN.

Rev	P9242-R3 MM Board V 2.1
Size	Document Number
Config	Manufacture: October 11, 2017
Sheet	1 of 1
Rev	2.2

5. Bill of Materials (BOM)

Table 1. P9221-R3-EVK BOM V2.2

Item	Quantity	Reference	Value	Description	Part Number	PCB Footprint
1	16	AC2T, VDD5V, VPP18, VOSET, TS, SDA, SCL, RPO, RPG, INT, ILIM, GCOM, DEN, ALGY, ALGX, /EN	PTH_TP	Test Pad		10MIL_35PAD
2	2	AC2, LC	NP	Test Point		test_pt_sm_135x70
3	4	C1, C2, C3, C5	100nF/ 50V	CAP CER 0.1UF 50V X5R 0402	GRM155R61H104KE19D	0402
4	2	C6, C14	47nF	CAP CER 0.047UF 50V X7R 0402	C1005X7R1H473K050BB	0402
5	2	C7, C15	NP	CAP CER 0.047UF 50V X7R 0402	C1005X7R1H473K050BB	0402
6	2	C8, C16	15nF	CAP CER 0.015UF 50V X7R 0402	GRM155R71H153KA12J	0402
7	1	C9	3.3nF	CAP CER 3300PF 50V X7R 0402	CL05B332KB5NNNC	0402
8	5	C10, C11, C21, C22, C33	10µF	CAP CER 10UF 25V X5R 0603	CL10A106MA8NRNC	0603
9	1	C12	NP	CAP CER 10UF 25V X5R 0603	CL10A106MA8NRNC	0603
10	1	C18	NP	CAP CER 1UF 10V X5R 0402	GRM155R61A105KE15D	0402
11	1	C20	1µF	CAP CER 1UF 10V X5R 0402	GRM155R61A105KE15D	0402
12	3	C19, C25, C31	0.1µF	CAP CER 0.1UF 10V X5R 0201	C0603X5R1A104K030BC	0201
13	1	C23	0.1µF	CAP CER 0.1UF 25V X5R 0201	CL03A104KA3NNNC	0201
14	1	D1	LED	LED GREEN CLEAR 0603 SMD	150060GS75000	0603_diode
15	2	D6,D7	5.1V	DIODE ZENER 5.1V 100MW 0201	CZRZ5V1B-HF	0201
16	5	GND1, VRECT, VOUT, VOSNS, GND	Test Point	TEST POINT PC MINIATURE SMT	5015	test_pt_sm_135x70
17	1	L1	RX coil	AMOTECH, Rx Power Coil	ASC-504060M22-S00	10MIL_35PAD
18	1	J1	NP	HEADER_1X5_0P1PITCH60P42D	68002-205HLF	header_1x5_0p1Pitch60 p42d
19	1	RTS	NP			NTC2
20	3	R1, R13, R14	5.1kΩ	RES SMD 5.1K OHM 5% 1/16W 0402	MCR01MRTJ512	0402
21	1	R2	36Ω	RES SMD 36 OHM 5% 1/2W 0805	ERJ-P06J360V	0805
22	1	R6	NP	RES SMD 0.00HM 1/10W 0402	ERJ-2GE0R00X	0402
23	1	R8	0Ω	RES SMD 0.00HM 1/10W 0402	ERJ-2GE0R00X	0402
24	2	R15, R16	10kΩ	RES SMD 10KOHM 1% 1/10W 0603	RC0603FR-0710KL	0603
25	10	R17, R19, R23, R27, R28, R29, R30, R34, R38, R39	10kΩ	RES SMD 10K OHM 5% 1/10W 0402	ERJ-2GEJ103X	0402
26	3	R18, R22, ,R33	NP	RES SMD 10K OHM 5% 1/10W 0402	ERJ-2GEJ103X	0402
27	1	R35	0Ω	RES SMD 0.00HM JUMPER 1/10W 0603	MCR03EZPJ000	0603

Item	Quantity	Reference	Value	Description	Part Number	PCB Footprint
28	1	U1	P9221-R3	Wireless power receiver	P9221-R3	csp52_2p64x3p94_0p4mm
29	1	U2	NP	IC EEPROM 128KBIT 400KHZ 8TDFN	24AA128T-I/MNY	TDFN08

Table 2. P9242-R3-EVK BOM V2.1

Item	Quantity	Reference	Value	Description	Part Number	PCB Footprint
1	12	C1, C2, C3, C4, C13, C15, C21, C26, C29, C30, C33, C34	0.1μF	CAP CER 0.1μF 25V 10% X7R 0402	C1005X7R1E104K050BB	0402
2	7	C5, C14, C31, C37, C38, C40, C41	10μF	CAP CER 10μF 25V 20% X5R 0603	C1608X5R1E106M080AC	0603
3	4	C6, C12, C16, C27	1μF	CAP CER 1μF 25V 20% X5R 0402	C1005X5R1E105M050BC	0402
4	2	C7, C9	56pF	CAP CER 56PF 50V NP0 0402	CL05C560JB5NNNC	0402
5	1	C8	6.8nF	CAP CER 6800PF 25V X7R 0402	GRM155R71E682KA01D	0402
6	2	C10, C11	22nF	0.022μF 50V Ceramic Capacitor X7R 0603	GCM188R71H223KA37D	0603
7	1	C17	680pF	CAP CER 680PF 50V X7R 0402	CL05B681KB5NNNC	0402
8	1	C18	1nF	CAP CER 1000pF ±10% 50V X7R 0402	GRM155R71H102KA01D	0402
9	3	C19, C35, C39	5.6nF	5600pF 100V Ceramic Capacitor C0G, NP0 0603	C1608C0G2A562J080AC	0603
10	1	C20	100nF	CAP CER 0.1μF 100V C0G 1206	C3216C0G2A104K160AC	1206
11	1	C22	22nF	CAP CER 0.022μF 50V 10% X7R 0402	GRM155R71H223KA12D	0402
12	1	C23	68nF	CAP CER 0.068μF 100V NP0 1206	C3216C0G2A683K160AC	1206
13	1	C24	47nF	CAP CER 0.047μF 100V NP0 1206	C3216C0G2A473J115AC	1206
14	1	C25	NP	CAP CER 10000PF 100V C0G 1206	C3216C0G2A103J115AA	1206
15	2	C28, C32	22μF	CAP CER 22μF 25V 20% X5R 1206	GRM31CR61E226KE15L	1206
16	1	C36	0.1uF	CAP CER 0.1μF 25V 10% X7R 0402	C1005X7R1E104K050BB	0402
17	1	C42	0.1μF	0.10μF 50V Ceramic Capacitor X7R 0603	GRM188R71H104KA93D	0603
18	1	C43	1μF	1μF 25V Ceramic Capacitor X5R 0603	GRM188R61E105KA12D	0603
19	1	C44	4.7μF	4.7μF 25V Ceramic Capacitor X5R 0603	GRM188R61E475KE11D	0603
20	2	D1, D2	BAV21W	DIODE GEN PURP 80V 125MA DFN	BAV21W-7-F	sod123

Item	Quantity	Reference	Value	Description	Part Number	PCB Footprint
21	30	VLX1, VINT1, IO_B1, IO_A1, GNDT1, vs2, VLX2, VINT2, IO_B2, GNDT2, vs3, IO_B3, IO_B4, IO_A4, VCC5V, IO_B5, IO_A5, IO_B6, IO_A6, IO_B7, IO_A7, IO_B8, LDO18, LDO33, VSNS_IN, VCOIL, VBRG, IO_B0, IO_A0, ENB	PTH_TP	30 GAUGE WIRE PAD	NP	TEST_PT30DPAD
22	7	VIN1, GND1, GND2, GND3, GND4, VIN, GND	TP	TEST POINT PC MINIATURE SMT	5015	test_pt_sm_135x70
23	1	J1	5P	CONN RCPT MCR USB AB SMD TH SHLL	ZX62D-AB-5P8	usb_micro_ab
24	1	J2	68000-105HLF	BERGSTIK II .100" SR STRAIGHT	68000-105HLF	sip5
25	1	J3	AC Adapter	CONN POWER JACK 2.5X5.5MM HI CUR	PJ-002AH	CONN_POWER_JACK5_5MM
26	1	J4	TP	CONN HEADER 3POS .100" STR GOLD	901200763	sip3
27	1	J5	SIP con	4-position header	961104-6404-AR	sip-4
28	1	LED1	LED	LED RED CLEAR 0603 SMD	150060RS75000	0603_diode
29	1	LED2	LED	LED GREEN CLEAR 0603 SMD	150060GS75000	0603_diode
30	2	LX1, LX2	NP	Tx coil assemble through hole	NA	TP_TXCoil
31	1	L1	4.7μH	FIXED IND 4.7μH 620MA 500 MOHM	CIG10W4R7MNC	L0603
32	1	L2	NP	Common mode EMI choke	ACM4520-901-2P-T-000	EMI_TDK_ACM4520L
33	1	PZ1	NP	BUZZER PIEZO 4KHZ 12.2MM PC MNT	PS1240P02CT3	9235_buzzer
34	4	Q1, Q2, Q3, Q4	DMG7430LFG	MOSFET N-CH 30V 10.5A PWRDI3333	DMG7430LFG-7	powerdi3333_8ld_fet
35	3	Q5, Q7, Q8	2N7002	N-Channel 60-V (D-S) MOSFET	2N7002KT1G	SOT23_3
36	1	Q6	MOSFET	MOSFET P-CH 30V 24A PPAK SC-70-6	SIA453EDJ-T1-GE3	sc70_6ld_fet
37	1	RTH1	NP	NTC thermistor 10k bead	NTCLE203E3103JB0	0805
38	3	R1, R3, R7	1kΩ	RES SMD 1K OHM 5% 1/16W 0402	RC0402JR-071KL	0402
39	1	R4	680Ω	RES SMD 680 OHM 5% 1/16W 0402	RC0402JR-07680RL	0402
40	1	R5	NP	RES SMD 0.0 OHM JUMPER 1/10W	RC0402JR-070RL	0402
41	9	R6, R13, , R16, R20, R23, R41, R42, R43, R48	10kΩ	RES SMD 10K OHM 1% 1/10W 0402	RC0402FR-0710KL	0402
42	5	R8, R26, R30, R31, R32	100kΩ	RES SMD 100K OHM 5% 1/10W 0402	ERJ-2GEJ104X	0402

Item	Quantity	Reference	Value	Description	Part Number	PCB Footprint
43	1	R24	100K	RES SMD 100K OHM 5% 1/10W 0402	ERJ-2GEJ104X	0402
44	1	R9	NP	RES SMD 100 OHM 5% 1/10W 0603	RC0603JR-07100RL	0603
45	2	R10, R12	390k Ω	RES SMD 390K OHM 5% 1/10W 0603	ERJ-3GEYJ394V	0603
46	1	R14	2.4k Ω	RES SMD 2.4K OHM 5% 1/10W 0402	ERJ-2GEJ242X	0402
47	2	R11, R35	200k Ω	RES SMD 200K OHM 1% 1/10W 0603	RC1608F204CS	0603
48	2	R15, R21	10 Ω	RES SMD 10 OHM 1% 1/10W 0402	ERJ-2RKF10R0X	0402
49	1	R18	0.02 Ω	RES SMD 0.02 OHM 1% 1/8W 0805	WSL0805R0200FEA	0805
50	4	R19, R22, R40, R44	NP	RES SMD 10K OHM 1% 1/10W 0402	RC0402FR-0710KL	0402
51	4	R25, R27, R28, R29	12 Ω	RES SMD 12 OHM 5% 1/10W 0402	ERJ-2GEJ120X	0402
52	1	R33	3 Ω	RES SMD 3 OHM 1% 1/8W 0805	RC0805FR-073RL	0805
53	1	R34	100k Ω	RES SMD 100K OHM 1% 1/10W 0603	ERJ-3EKF1003V	0603
54	2	R36, R37	0.1 Ω	RES SMD 0.1 OHM 5% 1/6W 0402	ERJ-2BSJR10X	0402
55	2	R38, R39	0 Ω	RES SMD 0.0 OHM JUMPER 1/10W	RC0402JR-070RL	0402
56	1	R45	220 Ω	RES SMD 220 OHM 1% 0.4W 0805	RC1206FR-07220RL	1206
57	2	R46, R47	5.1k Ω	RES SMD 5.1K OHM 5% 1/16W 0402	MCR01MRTJ512	0402
58	1	U1 ^[a]	P9242-RB	Transmitter (Bootloader Part)	P9242-RB	socketqfn_48_6x6_0p4
59	1	U2	W25X20 CLUXIG	SPIFLASH 2M-BIT 4KB UNIFORM SECT	W25X20CLUXIG TR	uson_2x3_8LD

[a] The P9242-RB offers a pre-programmed bootloader that must be used in conjunction with an external flash. Bi-directional communications firmware is loaded into the external flash. The firmware can be customized in external flash. There is no functionality difference between the P9242-R3 V2.1 Evaluation board with P9242-R3 IC and the P9242-RB with external flash.

6. Partner Products Information

6.1 Evaluation Kits

Renesas partnered with Würth Elektronik to build a development kit for customers with the same bill of materials and reference designators as the WP15WBD-RK. For more information on the development kit, see the Würth Elektronik [website](#).



6.2 Transmitter Coils

Table 3. Recommended Transmitter Coil Manufactures

Output Power	Vendor	Part Number	Inductance at 100kHz	DCR at 20°C
15W	SUNLORD	SWA53N53H30C11B	10 μ H	50m Ω
15W	TDK	WT525225-12F2-MA2-G	10.6 μ H	40m Ω
15W	WURTH	760308103102	10 μ H	55m Ω

6.3 Receiver Coils

Table 4. Recommended Receiver Coil Manufacturers

Output Power	Vendor	Part Number	Inductance at 100kHz	ACR at 20°C	Series Resonant Capacitance
15W	AMOTECH	ASC-504060E00-S00	8.2μH	220mΩ	400nF
15W	TDK	WR424245-13K2-G	11.2μH	170mΩ	300nF
15W	SUNLORD	SWA50R40H06C02B	8.4μH	150mΩ	400nF
15W	WURTH	760308102207	8.0μH	80mΩ	400nF

7. Ordering Information

Orderable Part Number	Description
WP15WBD-RK	WP15WBD-RK Bi-directional Data Transfer Evaluation Kit including P9242-R3-EVK Transmitter Evaluation Board, P9221-R3-EVK Receiver Evaluation Board, two USB to I2C Dongles, and 12V/2A AC Adapter.

8. Revision History

Revision Date	Description of Change
April 3, 2020	<ul style="list-style-type: none"> ▪ Added Partner Products Information
November 21, 2018	<ul style="list-style-type: none"> ▪ Updated Figure 7 (and added note below figure) and Figure 8 ▪ Updated Table 2
October 19, 2017	Initial release.

IMPORTANT NOTICE AND DISCLAIMER

RENESAS ELECTRONICS CORPORATION AND ITS SUBSIDIARIES (“RENESAS”) PROVIDES TECHNICAL SPECIFICATIONS AND RELIABILITY DATA (INCLUDING DATASHEETS), DESIGN RESOURCES (INCLUDING REFERENCE DESIGNS), APPLICATION OR OTHER DESIGN ADVICE, WEB TOOLS, SAFETY INFORMATION, AND OTHER RESOURCES “AS IS” AND WITH ALL FAULTS, AND DISCLAIMS ALL WARRANTIES, EXPRESS OR IMPLIED, INCLUDING, WITHOUT LIMITATION, ANY IMPLIED WARRANTIES OF MERCHANTABILITY, FITNESS FOR A PARTICULAR PURPOSE, OR NON-INFRINGEMENT OF THIRD PARTY INTELLECTUAL PROPERTY RIGHTS.

These resources are intended for developers skilled in the art designing with Renesas products. You are solely responsible for (1) selecting the appropriate products for your application, (2) designing, validating, and testing your application, and (3) ensuring your application meets applicable standards, and any other safety, security, or other requirements. These resources are subject to change without notice. Renesas grants you permission to use these resources only for development of an application that uses Renesas products. Other reproduction or use of these resources is strictly prohibited. No license is granted to any other Renesas intellectual property or to any third party intellectual property. Renesas disclaims responsibility for, and you will fully indemnify Renesas and its representatives against, any claims, damages, costs, losses, or liabilities arising out of your use of these resources. Renesas' products are provided only subject to Renesas' Terms and Conditions of Sale or other applicable terms agreed to in writing. No use of any Renesas resources expands or otherwise alters any applicable warranties or warranty disclaimers for these products.

(Rev.1.0 Mar 2020)

Corporate Headquarters

TOYOSU FORESIA, 3-2-24 Toyosu,
Koto-ku, Tokyo 135-0061, Japan
www.renesas.com

Contact Information

For further information on a product, technology, the most up-to-date version of a document, or your nearest sales office, please visit:
www.renesas.com/contact/

Trademarks

Renesas and the Renesas logo are trademarks of Renesas Electronics Corporation. All trademarks and registered trademarks are the property of their respective owners.