

File: EQUIPMENT MANUAL - Section 610
Replaces: NOTHING
Dist: 1, 1a, 1b, 1c, 4, 4b, 4c

AGHN

NH₃ Evaporator

Ammonia Industrial Applications 1-63 Tons

Manufactured with Stainless Steel Tubes



CONTENTS

STANDARD FEATURES	3
CASING.....	3
DRAIN PAN	3
TUBE.....	3
FINS.....	3
COIL CIRCUITING.....	3
FANS & MOTORS.....	3
DEFROST	4
ELECTRICAL.....	4
PACKING AND PREPARATION FOR SHIPMENT	4
OPTIONAL FEATURES.....	4
CONSTRUCTION MATERIALS	4
FANS AND MOTORS	4
DEFROST OPTIONS.....	4
ELECTRICAL.....	4
NOMENCLATURE.....	5
PERFORMANCE DATA: 1 FAN MODELS	6
PHYSICAL, SOUND, ELECTRICAL DATA: 1 FAN MODELS.....	7
PERFORMANCE DATA: 2 FAN MODELS	9
PHYSICAL, SOUND, ELECTRICAL DATA: 2 FAN MODELS.....	10
PERFORMANCE DATA: 3 FAN MODELS	12
PHYSICAL, SOUND, ELECTRICAL DATA: 3 FAN MODELS.....	13
PERFORMANCE DATA: 4 FAN MODELS.....	15
PHYSICAL, SOUND, ELECTRICAL DATA: 4 FAN MODELS	16
DIMENSIONS: 1 FAN MODELS	18
DRAWING: 1 FAN MODELS.....	19
DIMENSIONS: 2 FAN MODELS	20
DRAWING: 2 FAN MODELS	21
DIMENSIONS: 3 FAN MODELS	22
DIMENSIONS: 3 FAN MODELS	22
DRAWING: 3 FAN MODELS	23
DRAWING: 3 FAN MODELS	23
DIMENSIONS: 4 FAN MODELS.....	24
DRAWING: 4 FAN MODELS.....	25

STANDARD FEATURES

CASING

The casing is treated, corrosion resistant, and painted galvanized steel sheet for models 28" (710 mm) diameter and larger. Corrosion, seawater resistant aluminum (AlMg3) is available for fan diameters up to 20" (500 mm). All casing is powder coated - color RAL 9003 (Signal White) and suitable for stringent, USDA food industry applications.

The casing design provides easy access and does not allow for "tight spots". Components are easy to reach for service and cleaning purposes. Components can be easily accessed through hinged side panels that have snap lock on models with 28" (710 mm) fans or larger.

Fan orifices, with full Venturi nozzles, are optimized to assure maximum efficiency, air throw, and airflow. All fans are individually compartmented within complete tube sheets to allow fan cycling for capacity control.

All hangers and fittings used for construction and assembly are manufactured from stainless steel 304. Easily removable side panels, complete with PVC handles, simplify access to internal and electrical components.

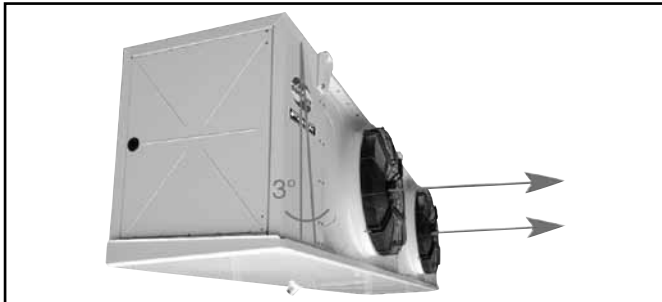

Figure 1 - Unit with 3° inclination

New incline design provides efficient drainage and air flow. The inclination is 3° on 710 mm and up. See Figure 1.

DRAIN PAN

The casing is treated, corrosion resistant, and painted galvanized steel sheet for models 28" (710 mm) diameter and larger. Corrosion, seawater resistant aluminum (AlMg3) is available for fan diameters up to 20" (500 mm). Drain pans (outer) are powder coated color RAL 9003 (Signal White). All drain pans are unique "hinged" type and can be either dropped down or completely removed, if required, for cleaning purposes. Sloped design of the drain pan (Figure 2) for all models ensures maximum and efficient drainage during defrost cycle.

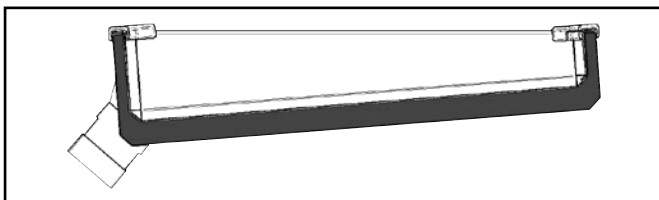

Figure 2 - Sloped Drain Pan

TUBE

All tubing, headers and connections are 5/8" (15 mm) 304 stainless steel. Parallel, "in-line," 1.969" x 1.969" (50 x 50 mm) allows for reduced air-side pressure drop through the coil. Tubes are mechanically expanded to assure bonding and efficient heat transfer from fin to tube. Our proven "floating coil" with support tubes does not permit the refrigerant tubes to come into contact with the tube / end plates and eliminates risk of tube failure at the end plates. All coils are hydrostatically tested to 450 psig with dry air, under water, and shipped with a holding charge.

FINS

Aluminum fins with corrugated pattern enhance air turbulence, assuring contact with all surfaces within the coil bundle. Die-formed finned collars, 100% drawn, are standard and result in accurate fin spacings of 6.3, 4.2, 3.2, 2.5, and 2.1 FPI (4, 6, 8, 10, and 12 mm). All fins are manufactured to reduce the risk of frost build-up, air-side pressure drops, dust, dirt and bacteria - simplifying any cleaning procedure.

COIL CIRCUITING

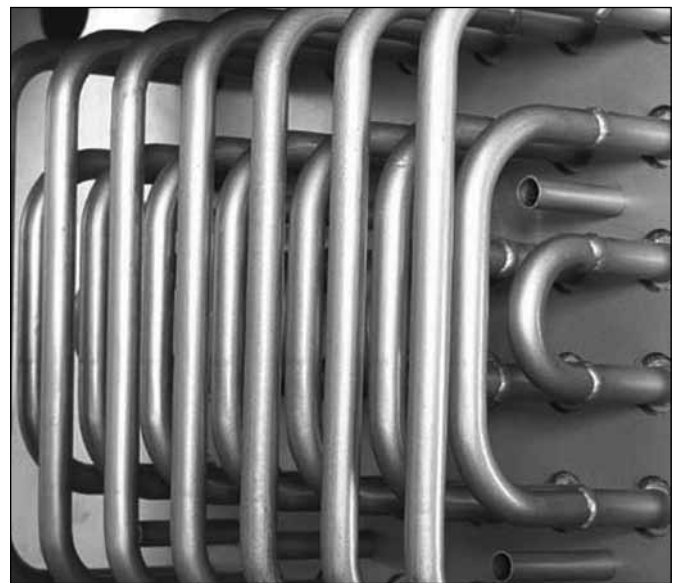

Figure 3 - Coil Circuiting

Each unit is specifically circuited to optimize coil performance and capacity with a low pressure drop. We recommend consulting selection software to obtain best circuiting for each application. Horizontal headers are standard for recirculated and flooded applications. For larger capacities and vertical headers, please consult our application engineers. Standard coil connections are manufactured from carbon black steel, as per ASME B31.5 requirements.

FANS & MOTORS

External rotor axial fans are standard for the entire range at 0" ESP and some 1/4" ESP applications. Prop-type impellers are used for higher ESP's. Standard impellers are die cast aluminum. External rotor motors are maintenance free and provide extended life and low noise levels. Fan guards are galvanized steel and PVC coated. All motors are of the draw-through type. Standard voltages include 230V and 460V for 60Hz applications and 400V for 50Hz applications.

DEFROST

Air, electric, hot gas or water defrost are standard options for all units. Electric heater elements are stainless steel sheathed and fit directly into tubes within the coil bundle to provide for enhanced heat transfer during the defrost cycle. Elements are held in place with clips to prevent them from moving during transport or operation.

ELECTRICAL

All fan motors are factory wired to the junction box with single-point connection (factory installed jumpers can be removed for individual / capacity control). All heater wiring is terminated within a junction box for quick and simple field connections. When heater circuit amperages are in excess of 48 amps, multiple circuits are provided in order to comply with the NEC limitation of 48 amps per circuit.

PACKING AND PREPARATION FOR SHIPMENT

All units are positioned, crated and shipped to facilitate installation. Drain pans may be supplied separately in the same crate and can be fitted to the unit after the unit is hung. For leg mount units the drain pan is usually prefitted.

OPTIONAL FEATURES

CONSTRUCTION MATERIALS

- Change entire casing, tube sheets, and drain pan to either 304 or 316 stainless steel
- Units are supplied standard with carbon steel black pipe connections but can be ordered with either stainless steel pipe, flanges (ANSI B16.5) or carbon steel threaded connection (ASME B1.20).
- Insulated drain pan (recommended for certain food / processing applications)
- Oversized, extended drain pan
- Epoxy-coated aluminum or stainless steel (304 or 316) fins
- Choice of coil connection side
- Variable fin spacing
- Leg mounts (galvanized or stainless) or wall mount for all units (Ceiling hung is standard)
- Extended legs / leg mounts

FANS AND MOTORS

- Two-speed, premium efficiency or explosion proof motors
- Air throw unit / streamer factory fitted to fan guard (shipped loose)
- Air distribution sock connections on fan panel
- Swiveling fans (see Figure 4)
- Blow-through option on some models

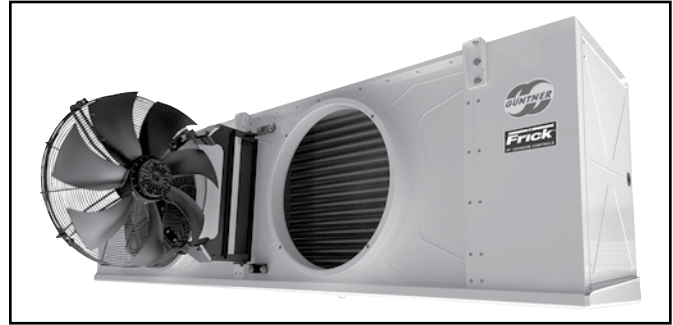

Figure 4 - Swiveling Fans

DEFROST OPTIONS

Air, electric, hot gas or water defrost are standard options for all units. Additional options are listed below.

- Water defrost pan – Overall height, depth and width will change
- Reheat coils – separated from the cooling coil by means of an air gap
- Fan ring heater – normal and low temperature versions, available in 230 and 460V
- For electric defrost - defrost termination and fan delay thermostat are factory installed
- Heater limit thermostat installed and prewired
- Factory installed check valve
- Defrost flap – Contains heat within the evaporator casing

ELECTRICAL

- Wired to junction box
- All motors wired to common/individual nonfused disconnect.
- All motors wired to common fused disconnect with thermal protection for each motor.
- All motors wired to fused disconnect with single starter and thermal protection for each motor.
- Custom: Various wiring options are available – please consult with application engineer for an alternative to suit your specific requirements.

NOMENCLATURE

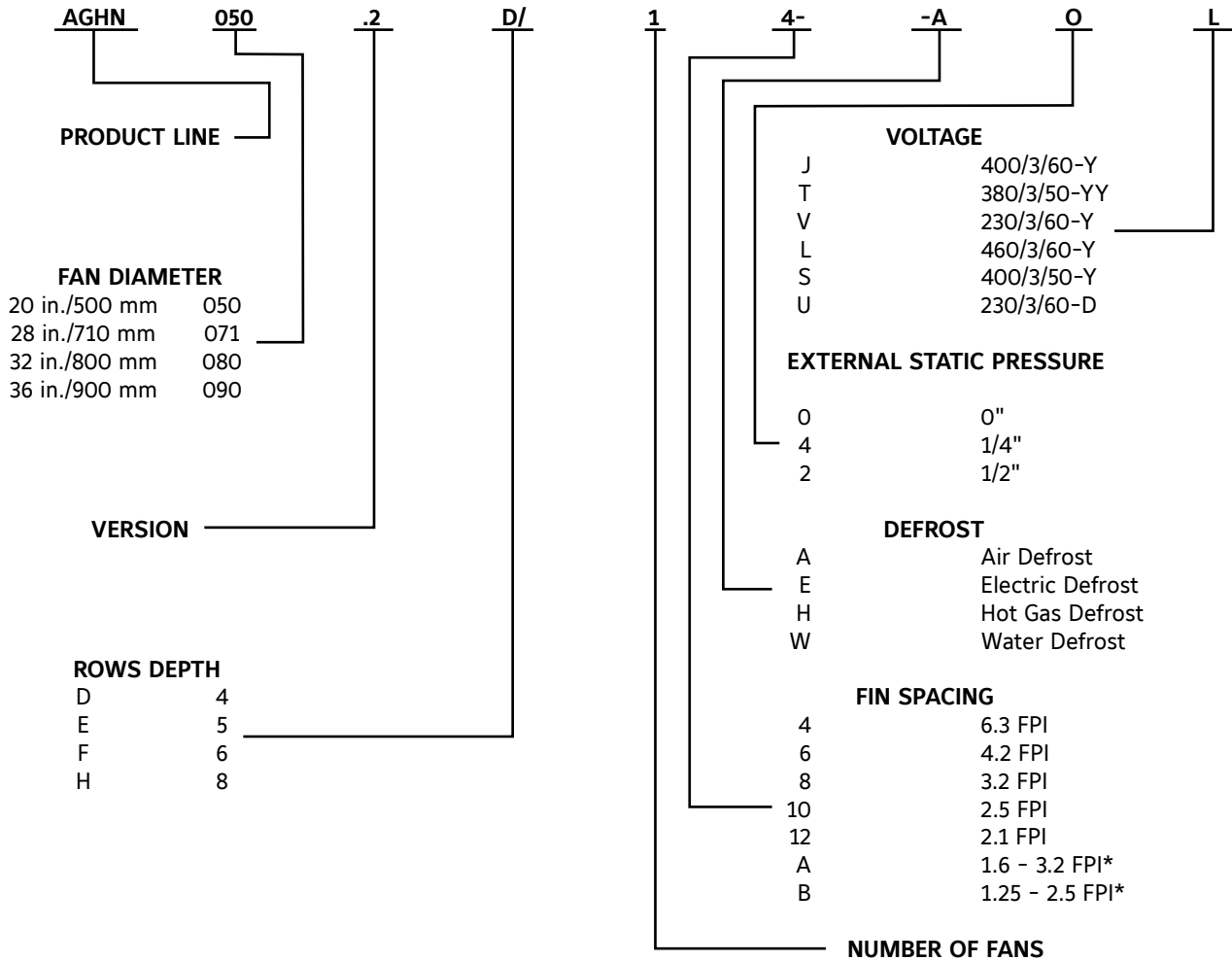

*First 2 rows in the air inlet side direction have the wider fin spacing

FAN MOTORS - ELECTRICAL SPECIFICATIONS									
ESP	UNIT MODEL FAN	FAN DIAMETER		Motor Ratings @3Ph/60Hz (ea.)				SOUND Power Level dB (A)	Spare Part No.
		mm	inch	Voltage	HP	rpm	FLA		
0	050...	500	19 ¹ / ₁₆	460	1/2	1390	1.25	56	VT01283U
	071...	710	28	460	3/4	1160	1.85	63	VT01245U
	080...	800	31 ¹ / ₂	460	1	1090	2.30	64	VT01249U
	090...	900	35 ⁷ / ₁₆	460	1 ¹ / ₂	700	4.10	60	VT01197U
1/2	050...	500	19 ¹ / ₁₆	460	1	1725	1.70	65	56081
	071...	710	28	460	1 ¹ / ₂	1725	2.40	64	56082
	080...	800	31 ¹ / ₂	460	3	1725	4.15	68	56084
	090...	900	35 ⁷ / ₁₆	460	5	1160	7.50	68	56087
1/4	050...	500	19 ¹ / ₁₆	460	3/4	1725	1.50	62	56080
	071...	710	28	460	1	1160	1.80	61	56083
	080...	800	31 ¹ / ₂	460	2	1160	3.50	64	56085
	090...	900	35 ⁷ / ₁₆	460	3	1160	4.60	65	56086

PERFORMANCE DATA: 1 FAN MODELS

Model No. AGHN 2	Coil Capacity & Air Flow											
	ESP: 0 in H ₂ O				ESP: 1/4 in H ₂ O				ESP: 1/2 in H ₂ O			
	Wet	Frosted	Air Flow	Face Velocity	Wet	Frosted	Air Flow	Face Velocity	Wet	Frosted	Air Flow	Face Velocity
	Btu/hr °F TD	Btu/hr °F TD	cfm	fpm	Btu/hr °F TD	Btu/hr °F TD	cfm	fpm	Btu/hr °F TD	Btu/hr °F TD	cfm	fpm
050.2D/14-	2,696	2,395	3,962	495	2,671	2,372	3,856	482	2,865	2,551	4,792	599
050.2E/14-	3,241	3,038	3,856	482	3,196	3,006	3,739	467	3,489	3,231	4,657	582
050.2F/14-	3,985	3,608	3,786	473	3,915	3,559	3,633	454	4,303	3,828	4,557	570
071.2D/14-	4,722	4,257	6,747	519	4,642	4,189	6,435	495	5,063	4,544	8,248	634
071.2E/14-	5,797	5,283	6,488	499	5,701	5,214	6,229	479	6,296	5,585	8,019	617
071.2F/14-	6,851	6,996	6,253	481	6,738	5,926	6,017	463	7,496	6,437	7,807	601
080.2D/14-	7,407	6,703	10,580	504	7,407	6,703	10,580	504	8,014	7,182	13,347	636
080.2E/14-	9,046	8,360	10,215	486	9,061	8,371	10,256	488	9,948	9,047	13,023	620
080.2F/14-	10,897	10,059	10,380	494	10,724	9,915	9,968	475	11,820	10,769	12,741	607
090.2E/14-	12,819	10,789	14,136	487	12,819	10,789	14,136	487	14,038	11,458	18,257	630
090.2F/14-	15,060	13,876	13,736	474	15,060	13,876	13,736	474	16,673	15,216	17,857	616
050.2E/16-	2,112	2,049	4,051	506	2,081	2,020	3,903	488	2,259	2,187	4,822	603
050.2F/16-	2,911	2,825	3,974	497	2,866	2,783	3,815	477	3,109	3,011	4,745	593
050.2H/16-	3,935	3,818	3,815	477	3,861	3,752	3,633	454	4,209	4,075	4,557	570
071.2E/16-	4,538	3,778	6,847	527	3,827	3,717	6,565	505	4,202	4,069	8,354	643
071.2F/16-	5,843	4,605	6,694	515	4,657	4,522	6,382	491	5,125	4,961	8,172	629
071.2H/16-	7,850	7,091	6,329	487	6,985	6,788	6,046	465	7,657	7,421	7,783	599
080.2E/16-	7,033	6,839	10,703	510	6,839	6,839	10,703	510	7,646	7,415	13,512	643
080.2F/16-	8,592	8,351	10,497	500	8,580	8,339	10,456	498	9,330	9,043	13,223	630
080.2H/16-	11,608	11,278	10,009	477	11,608	11,278	10,009	477	12,649	12,263	12,699	605
090.2F/16-	11,852	11,519	14,536	501	11,817	11,485	14,418	497	12,797	12,406	17,969	620
090.2H/16-	15,977	15,523	13,794	476	16,568	16,100	13,794	476	18,170	17,606	17,857	616
050.2D/18-	1,806	1,621	4,198	525	1,783	1,604	4,068	509	1,933	1,709	4,987	623
050.2E/18-	2,123	2,039	4,127	516	2,089	2,008	3,974	497	2,284	2,181	4,910	614
050.2F/18-	2,714	2,562	4,062	508	2,667	2,523	3,903	488	2,924	2,733	4,840	605
050.2H/18-	3,698	3,324	3,933	492	3,622	3,270	3,756	470	3,981	3,515	4,657	582
071.2E/18-	3,842	3,648	7,030	541	3,768	3,585	6,718	517	4,175	3,927	8,560	658
071.2F/18-	4,770	4,417	6,877	529	4,675	4,343	6,565	505	5,185	4,731	8,378	644
071.2H/18-	5,888	5,709	6,565	505	5,762	5,597	6,276	483	6,460	6,217	8,019	617
080.2E/18-	5,935	5,672	10,904	519	5,935	5,672	10,904	519	6,547	6,198	13,753	655
080.2F/18-	7,222	6,905	10,745	512	7,222	6,905	10,745	512	7,982	7,553	13,553	645
080.2H/18-	9,588	9,212	10,380	494	9,552	9,181	10,297	490	10,643	10,105	13,023	620
090.2F/18-	9,740	9,409	14,937	515	9,690	9,364	14,766	509	10,798	10,355	18,940	653
090.2H/18-	13,195	12,750	14,307	493	13,146	12,707	14,195	489	14,769	14,114	18,257	630
050.2D/110-	1,539	1,416	4,157	520	1,532	1,410	4,109	514	1,665	1,511	5,028	628
050.2E/110-	1,940	1,712	4,098	512	1,931	1,703	4,051	506	2,092	1,851	4,969	621
050.2F/110-	2,293	2,188	4,062	508	2,271	2,169	3,974	497	2,489	2,356	4,910	614
050.2H/110-	3,198	2,937	3,962	495	3,155	2,904	3,845	481	3,459	3,128	4,739	592
071.2E/110-	3,230	3,097	7,059	543	3,183	3,054	6,824	525	3,533	3,361	8,690	668
071.2F/110-	4,074	3,833	7,006	539	4,000	3,771	6,718	517	4,440	4,128	8,560	658
071.2H/110-	5,457	5,147	6,718	517	5,350	5,059	6,435	495	5,967	5,555	8,195	630
080.2F/110-	6,134	5,901	10,904	519	6,134	5,901	10,904	519	6,787	6,478	13,753	655
080.2H/110-	8,254	7,963	10,539	502	8,254	7,963	10,539	502	9,164	8,760	13,265	632
090.2F/110-	8,484	8,189	15,225	525	8,412	8,124	14,937	515	9,384	8,996	19,170	661
090.2H/110-	12,091	11,260	14,648	505	12,026	11,209	14,477	499	13,441	12,290	18,599	641
050.2D/112-	1,363	1,272	4,198	525	1,357	1,267	4,157	520	1,477	1,363	5,075	634
050.2E/112-	1,719	1,535	4,157	520	1,711	1,529	4,109	514	1,858	1,630	5,028	628
050.2F/112-	2,012	1,931	4,127	516	1,996	1,916	4,051	506	2,187	2,085	4,987	623
050.2H/112-	2,835	2,641	4,004	500	2,813	2,623	3,933	492	3,083	2,832	4,840	605
071.2E/112-	2,965	2,746	7,265	559	2,909	2,697	6,953	535	3,221	2,976	8,849	681
071.2F/112-	3,672	3,409	7,159	551	3,605	3,348	6,847	527	3,978	3,680	8,719	671
071.2H/112-	4,855	4,615	6,877	529	4,761	4,535	6,588	507	5,306	4,990	8,378	644
080.2F/112-	5,375	5,188	11,069	527	5,375	5,188	11,069	527	5,955	5,711	13,959	665
080.2H/112-	7,300	7,056	10,703	510	7,313	7,068	10,745	512	8,125	7,794	13,553	645
090.2F/112-	7,442	7,196	15,508	535	7,368	7,127	15,166	523	8,219	7,905	19,399	669
090.2H/112-	10,110	9,791	14,995	517	10,037	9,725	14,766	509	11,243	10,818	18,940	653
050.2F/1A-	2,724	2,570	4,098	512	2,684	2,537	3,962	495	2,939	2,745	4,898	612
050.2H/1A-	3,710	3,332	3,962	495	3,648	3,289	3,815	477	4,003	3,529	4,716	589
071.2F/1A-	4,793	4,434	6,953	535	4,715	4,374	6,694	515	5,217	4,755	8,507	654
071.2H/1A-	5,910	5,729	6,618	509	5,798	5,630	6,359	489	6,496	6,249	8,119	625
080.2F/1A-	7,246	6,926	10,827	516	7,259	6,937	10,868	518	8,021	7,585	13,712	653

Performance Data: Sensible capacity at specific conditions

PERFORMANCE DATA: 1 FAN MODELS

Model No. AGHN 2	Coil Capacity & Air Flow											
	ESP: 0 in H ₂ O				ESP: 1/4 in H ₂ O				ESP: 1/2 in H ₂ O			
	Wet	Frosted	Air Flow	Face Velocity	Wet	Frosted	Air Flow	Face Velocity	Wet	Frosted	Air Flow	Face Velocity
	Btu/hr /°FTD	Btu/hr /°FTD	cfm	fpm	Btu/hr /°FTD	Btu/hr /°FTD	cfm	fpm	Btu/hr /°FTD	Btu/hr /°FTD	cfm	fpm
080.2H/1A-	9,604	9,225	10,415	496	9,619	9,239	10,450	498	10,688	10,143	13,147	626
090.2F/1A-	10,046	9,651	15,166	523	9,961	9,576	14,878	513	11,101	10,570	19,117	659
090.2H/1A-	13,270	12,816	14,477	499	13,221	12,773	14,366	495	14,830	14,166	18,428	635
050.2F/1B-	2,309	2,202	4,127	516	2,290	2,186	4,051	506	2,506	2,370	4,987	623
050.2H/1B-	3,223	2,956	4,033	504	3,177	2,921	3,903	488	3,484	3,147	4,822	603
071.2F/1B-	4,164	3,571	7,159	551	4,303	3,987	7,783	599	4,495	4,156	8,719	671
071.2H/1B-	5,486	5,170	6,794	523	5,726	5,365	7,471	575	6,017	5,595	8,354	643
080.2F/1B-	6,175	5,938	11,069	527	6,175	5,938	11,069	527	6,830	6,516	13,959	665
080.2H/1B-	8,284	7,990	10,621	506	8,314	8,016	10,703	510	9,227	8,814	13,471	641
090.2F/1B-	8,554	8,252	15,508	535	8,470	8,176	15,166	523	9,432	9,039	19,399	669
090.2H/1B-	11,479	11,107	14,878	513	11,418	11,051	14,707	507	12,777	12,261	18,828	649

Performance Data: Sensible capacity at specific conditions

PHYSICAL, SOUND, ELECTRICAL DATA: 1 FAN MODELS

Model No. AGHN 2	Coil				Unit		Electrical Defrost			
	Face Area ft ²	Surface Area ft ²	Tube Volume ft ³	Fin Spacing fpi	Sound Pressure Level dB(A)	Air Throw ft	Total kW	Coil W	Tray W	AMP DRAWS @ 3/460 ** A
050.2D/14-	8	724	0.393	6.3	62	62	4.30	3,000	1,300	5.4
050.2E/14-	8	905	0.491		62	62	5.05	3,750	1,300	6.3
050.2F/14-	8	1,086	0.589		65	59	6.45	4,500	1,950	8.1
071.2D/14-	13	1,266	0.656		64	105	8.95	6,250	2,700	11.2
071.2E/14-	13	1,582	0.802		64	105	10.20	7,500	2,700	12.8
071.2F/14-	13	1,898	0.984		64	102	11.45	8,750	2,700	14.4
080.2D/14-	21	1,985	1.009		68	128	12.45	9,000	3,450	15.6
080.2E/14-	21	2,481	1.262		68	125	15.45	12,000	3,450	19.4
080.2F/14-	21	2,978	1.514		68	121	16.95	13,500	3,450	21.3
090.2E/14-	29	3,490	1.752		68	98	19.95	16,200	3,750	25.0
090.2F/14-	29	4,187	2.102	68	102	25.35	21,600	3,750	31.8	
050.2E/16-	8	615	0.491	4.2	65	62	5.05	3,750	1,300	6.3
050.2F/16-	8	738	0.589		65	59	6.45	4,500	1,950	8.1
050.2H/16-	8	985	0.786		65	62	9.45	6,750	2,700	11.9
071.2E/16-	13	1,076	0.802		64	105	10.20	7,500	2,700	12.8
071.2F/16-	13	1,291	0.984		64	102	11.45	8,750	2,700	14.4
071.2H/16-	13	1,722	1.313		64	105	13.95	11,250	2,700	17.5
080.2E/16-	21	1,688	1.262		68	125	15.45	12,000	3,450	19.4
080.2F/16-	21	2,025	1.514		68	121	16.95	13,500	3,450	21.3
080.2H/16-	21	2,701	2.019		68	125	21.45	18,000	3,450	26.9
090.2F/16-	29	2,848	2.102		68	102	25.35	21,600	3,750	31.8
090.2H/16-	29	3,798	2.803	68	98	32.00	27,000	5,000	40.2	
050.2D/18-	8	376	0.393	3.2	65	62	4.30	3,000	1,300	5.4
050.2E/18-	8	470	0.477		65	62	5.05	3,750	1,300	6.3
050.2F/18-	8	564	0.589		65	59	6.45	4,500	1,950	8.1
050.2H/18-	8	752	0.786		65	62	9.45	6,750	2,700	11.9
071.2E/18-	13	822	0.820		64	105	10.20	7,500	2,700	12.8
071.2F/18-	13	987	0.984		64	102	11.45	8,750	2,700	14.4
071.2H/18-	13	1,316	1.313		64	105	12.45	9,000	3,450	15.6
080.2E/18-	21	1,290	1.262		68	125	15.45	12,000	3,450	19.4
080.2F/18-	21	1,548	1.514		68	121	16.95	13,500	3,450	21.3
080.2H/18-	21	2,064	2.019		68	125	21.45	18,000	3,450	26.9
090.2F/18-	29	2,176	2.102	68	102	25.35	21,600	3,750	31.8	
090.2H/18-	29	2,902	2.803	68	98	32.00	27,000	5,000	40.2	

* First 2 rows on air inlet side have wider fin spacing

** Units with heater amp draws greater than 48 amps will be supplied with multiple circuits as required by the NEC

PHYSICAL, SOUND, ELECTRICAL DATA: 1 FAN MODELS

Model No. AGHN 2	Coil				Unit		Electrical Defrost			
	Face Area ft ²	Surface Area ft ²	Tube Volume ft ³	Fin Spacing fpi	Sound Pressure Level dB(A)	Air Throw ft	Total kW	Coil W	Tray W	AMP DRAWS @ 3/460 ** A
050.2D/110-	8	307	0.393	2.5	65	62	4.30	3,000	1,300	5.4
050.2E/110-	8	384	0.491		65	62	5.05	3,750	1,300	6.3
050.2F/110-	8	460	0.589		65	59	6.45	4,500	1,950	8.1
050.2H/110-	8	614	0.786		65	62	8.70	6,750	1,950	10.9
071.2E/110-	13	671	0.820		64	105	10.20	7,500	2,700	12.8
071.2F/110-	13	805	0.984		64	102	11.45	8,750	2,700	14.4
071.2H/110-	13	1,073	1.313		64	105	13.95	11,250	2,700	17.5
080.2F/110-	21	1,262	1.514		68	121	16.95	13,500	3,450	21.3
080.2H/110-	21	1,683	2.019		68	125	21.45	18,000	3,450	26.9
090.2F/110-	29	1,775	2.102		68	102	25.35	21,600	3,750	31.8
090.2H/110-	29	2,367	2.803		68	98	32.00	27,000	5,000	40.2
050.2D/112-	8	261	0.393	2.1	65	62	4.30	3,000	1,300	5.4
050.2E/112-	8	326	0.491		65	62	5.05	3,750	1,300	6.3
050.2F/112-	8	391	0.589		65	59	6.45	4,500	1,950	8.1
050.2H/112-	8	521	0.786		65	62	8.70	6,750	1,950	10.9
071.2E/112-	13	570	0.802		64	105	10.20	7,500	2,700	12.8
071.2F/112-	13	683	0.984		64	102	11.45	8,750	2,700	14.4
071.2H/112-	13	911	1.313		64	105	13.95	11,250	2,700	17.5
080.2F/112-	21	1,072	1.514		68	121	16.95	13,500	3,450	21.3
080.2H/112-	21	1,429	2.019		68	125	21.45	18,000	3,450	26.9
090.2F/112-	29	1,508	2.102		68	102	25.35	21,600	3,750	31.8
090.2H/112-	29	2,010	2.803		68	98	32.00	27,000	5,000	40.2
050.2F/1A-	8	478	0.590	1.6 - 3.2*	65	59	6.45	4,500	1,950	8.1
050.2H/1A-	8	666	0.788		65	62	8.70	6,750	1,950	10.9
071.2F/1A-	13	835	0.935		64	102	11.45	8,750	2,700	14.4
071.2H/1A-	13	1,165	1.314		64	105	13.95	11,250	2,700	17.5
080.2F/1A-	21	1,311	1.515		68	121	16.95	13,500	3,450	21.3
080.2H/1A-	21	1,827	2.020		68	125	21.45	18,000	3,450	26.9
090.2F/1A-	29	1,843	2.101		68	102	25.35	21,600	3,750	31.8
090.2H/1A-	29	2,569	2.804		68	98	32.00	27,000	5,000	40.2
050.2F/1B-	8	391	0.590		1.25 - 2.5*	65	59	6.45	4,500	1,950
050.2H/1B-	8	545	0.788	65		62	8.70	6,750	1,950	10.9
071.2F/1B-	13	684	0.935	64		102	11.45	8,750	2,700	14.4
071.2H/1B-	13	952	1.314	64		105	13.95	11,250	2,700	17.5
080.2F/1B-	21	1,073	1.515	68		121	16.95	13,500	3,450	21.3
080.2H/1B-	21	1,494	2.020	68		125	21.45	18,000	3,450	26.9
090.2F/1B-	29	1,508	2.101	68		102	25.35	21,600	3,750	31.8
090.2H/1B-	29	2,100	2.804	68		98	32.00	27,000	5,000	40.2

* First 2 rows on air inlet side have wider fin spacing

** Units with heater amp draws greater than 48 amps will be supplied with multiple circuits as required by the NEC

PERFORMANCE DATA: 2 FAN MODELS

Model No. AGHN 2	Coil Capacity & Air Flow											
	ESP: 0 in H ₂ O				ESP: 1/4 in H ₂ O				ESP: 1/2 in H ₂ O			
	Wet	Frosted	Air Flow	Face Velocity	Wet	Frosted	Air Flow	Face Velocity	Wet	Frosted	Air Flow	Face Velocity
	Btu/hr °F TD	Btu/hr °F TD	cfm	fpm	Btu/hr °F TD	Btu/hr °F TD	cfm	fpm	Btu/hr °F TD	Btu/hr °F TD	cfm	fpm
050.2D/24-	5,425	4,803	7,925	528	5,375	4,757	7,713	514	5,770	5,109	9,585	639
050.2E/24-	6,612	6,020	7,713	514	6,533	5,950	7,477	498	7,092	6,183	9,314	621
050.2F/24-	7,983	7,165	7,565	504	7,854	7,050	7,265	484	8,563	7,668	9,114	608
071.2D/24-	9,473	8,541	13,488	519	9,312	8,404	12,870	495	10,162	9,121	16,497	634
071.2E/24-	11,735	10,310	12,970	499	11,550	10,153	12,458	479	12,703	11,132	16,038	617
071.2F/24-	13,742	12,560	12,505	481	13,514	12,371	12,034	463	15,045	13,637	15,614	601
080.2D/24-	14,859	13,462	21,160	516	14,859	13,462	21,160	516	16,086	14,435	26,694	651
080.2E/24-	18,114	16,790	20,430	498	18,144	16,812	20,512	500	19,926	18,148	26,046	635
080.2F/24-	21,880	20,201	20,753	506	21,533	19,912	19,935	486	23,675	21,643	25,481	621
090.2E/24-	25,054	23,522	28,272	487	25,054	23,522	28,272	487	27,730	25,590	36,514	630
090.2F/24-	29,500	27,835	27,471	474	29,500	27,835	27,471	474	32,951	30,544	35,714	616
050.2E/26-	5,186	5,044	8,101	540	5,117	4,980	7,807	520	5,511	5,351	9,644	643
050.2F/26-	6,692	6,511	7,954	530	6,597	6,421	7,630	509	7,106	6,900	9,491	633
050.2H/26-	9,080	8,829	7,624	508	8,930	8,688	7,265	484	9,646	9,361	9,114	608
071.2E/26-	9,339	9,089	13,700	527	9,198	8,956	13,129	505	10,014	9,725	16,709	643
071.2F/26-	11,405	11,086	13,388	515	11,204	10,905	12,764	491	12,220	11,860	16,344	629
071.2H/26-	15,374	14,952	12,658	487	16,533	16,037	12,093	465	15,126	14,717	15,567	599
080.2E/26-	14,964	14,580	21,407	522	14,964	14,580	21,407	522	16,200	15,744	27,024	659
080.2F/26-	18,181	17,697	21,001	512	18,154	17,672	20,912	510	19,663	19,091	26,447	645
080.2H/26-	24,331	23,662	20,023	488	26,420	25,620	20,018	488	24,328	23,660	25,399	619
090.2F/26-	24,578	23,899	29,072	501	24,506	23,831	28,837	497	26,516	25,718	35,937	620
090.2H/26-	33,174	32,252	27,583	476	33,177	32,254	27,589	476	36,398	35,264	35,714	616
050.2D/28-	3,621	3,268	8,396	560	3,575	3,235	8,137	542	3,877	3,451	9,973	665
050.2E/28-	4,395	4,126	8,248	550	4,328	4,070	7,948	530	4,722	4,388	9,820	655
050.2F/28-	5,587	5,027	8,131	542	5,492	4,963	7,807	520	6,001	5,314	9,679	645
050.2H/28-	6,853	6,643	7,866	524	6,706	6,510	7,512	501	7,406	7,136	9,314	621
071.2E/28-	7,881	7,320	14,059	541	7,731	7,201	13,435	517	8,551	7,838	17,121	658
071.2F/28-	9,550	8,871	13,747	529	9,361	8,723	13,129	505	10,385	9,511	16,756	644
071.2H/28-	12,426	11,811	13,129	505	12,163	11,593	12,552	483	13,624	12,783	16,038	617
080.2E/28-	11,878	11,367	21,813	532	11,876	11,366	21,807	532	13,102	12,423	27,506	671
080.2F/28-	14,452	13,837	21,489	524	14,452	13,837	21,489	524	15,974	15,140	27,106	661
080.2H/28-	19,184	18,457	20,753	506	19,114	18,397	20,594	502	21,299	20,257	26,046	635
090.2F/28-	20,619	19,532	29,873	515	20,515	19,445	29,532	509	22,830	21,343	37,880	653
090.2H/28-	26,400	25,535	28,613	493	26,301	25,448	28,390	489	29,552	28,276	36,514	630
050.2D/210-	3,084	2,849	8,307	554	3,070	2,839	8,219	548	3,338	3,044	10,056	670
050.2E/210-	3,683	3,507	8,190	546	3,667	3,492	8,101	540	3,997	3,773	9,938	663
050.2F/210-	4,751	4,379	8,131	542	4,705	4,343	7,948	530	5,144	4,675	9,820	655
050.2H/210-	6,409	5,913	7,925	528	6,322	5,847	7,689	513	6,934	6,304	9,479	632
071.2E/210-	6,642	6,273	14,112	543	6,546	6,193	13,647	525	7,259	6,781	17,380	668
071.2F/210-	8,154	7,690	14,006	539	8,007	7,567	13,435	517	8,889	8,289	17,121	658
071.2H/210-	10,926	10,330	13,441	517	10,709	10,151	12,870	495	11,947	11,156	16,391	630
080.2F/210-	12,816	12,023	21,813	532	12,814	12,022	21,807	532	14,152	13,088	27,506	671
080.2H/210-	16,515	15,948	21,077	514	16,515	15,948	21,077	514	18,337	17,550	26,529	647
090.2F/210-	17,567	16,799	30,444	525	17,420	16,671	29,873	515	19,417	18,389	38,339	661
090.2H/210-	23,578	22,608	29,302	505	23,447	22,495	28,955	499	26,271	24,899	37,197	641
050.2D/212-	2,730	2,556	8,396	560	2,718	2,546	8,307	554	2,959	2,741	10,150	677
050.2E/212-	3,236	3,101	8,307	554	3,221	3,088	8,219	548	3,513	3,344	10,056	670
050.2F/212-	4,180	3,909	8,248	550	4,148	3,882	8,101	540	4,537	4,192	9,973	665
050.2H/212-	5,681	5,311	8,013	534	5,634	5,273	7,866	524	6,177	5,700	9,679	645
071.2E/212-	5,875	5,595	14,530	559	5,762	5,498	13,906	535	6,400	6,043	17,698	681
071.2F/212-	7,184	6,835	14,318	551	7,043	6,714	13,694	527	7,829	7,382	17,439	671
071.2H/212-	9,716	9,253	13,747	529	9,528	9,093	13,176	507	10,621	10,012	16,756	644
080.2F/212-	11,260	10,675	22,137	540	11,260	10,675	22,137	540	12,456	11,670	27,919	681
080.2H/212-	15,272	14,487	21,407	522	15,299	14,510	21,489	524	16,974	15,888	27,106	661
090.2F/212-	15,432	14,836	31,015	535	15,279	14,699	30,332	523	17,030	16,246	38,799	669
090.2H/212-	20,943	20,159	29,985	517	20,795	20,028	29,532	509	23,280	22,200	37,880	653
050.2F/2A-	5,604	5,039	8,190	546	5,527	4,984	7,925	528	6,030	5,334	9,797	653
050.2H/2A-	6,877	6,664	7,925	528	6,755	6,555	7,630	509	7,448	7,173	9,432	629
071.2F/2A-	9,598	8,909	13,906	535	9,442	8,786	13,388	515	10,451	9,561	17,015	654
071.2H/2A-	12,471	11,848	13,229	509	12,240	11,656	12,717	489	13,700	12,843	16,238	625
080.2F/2A-	15,069	13,887	21,648	528	15,096	13,907	21,737	530	16,636	15,051	27,424	669

Performance Data: Sensible capacity at specific conditions

PERFORMANCE DATA: 2 FAN MODELS

Model No. AGHN 2	Coil Capacity & Air Flow											
	ESP: 0 in H ₂ O				ESP: 1/4 in H ₂ O				ESP: 1/2 in H ₂ O			
	Wet	Frosted	Air Flow	Face Velocity	Wet	Frosted	Air Flow	Face Velocity	Wet	Frosted	Air Flow	Face Velocity
	Btu/hr °F TD	Btu/hr °F TD	cfm	fpm	Btu/hr °F TD	Btu/hr °F TD	cfm	fpm	Btu/hr °F TD	Btu/hr °F TD	cfm	fpm
080.2H/2A-	19,220	18,488	20,836	508	19,249	18,513	20,901	510	21,389	20,332	26,294	641
090.2F/2A-	20,758	19,647	30,332	523	20,583	19,502	29,755	513	22,919	21,414	38,233	659
090.2H/2A-	26,549	25,667	28,955	499	26,452	25,581	28,731	495	29,676	28,382	36,856	635
050.2F/2B-	4,780	4,401	8,248	550	4,743	4,373	8,101	540	5,177	4,700	9,973	665
050.2H/2B-	6,462	5,953	8,072	538	6,365	5,880	7,807	520	6,985	6,342	9,644	643
071.2F/2B-	8,233	7,755	14,318	551	8,536	8,003	15,567	599	8,959	8,345	17,439	671
071.2H/2B-	10,983	10,377	13,594	523	11,465	10,769	14,942	575	12,048	11,236	16,709	643
080.2F/2B-	12,898	12,090	22,137	540	12,898	12,090	22,137	540	14,240	13,157	27,919	681
080.2H/2B-	17,282	16,239	21,242	518	17,343	16,288	21,407	522	19,212	17,760	26,941	657
090.2F/2B-	17,712	16,925	31,015	535	17,538	16,774	30,332	523	19,516	18,469	38,799	669
090.2H/2B-	23,747	22,753	29,755	513	23,620	22,644	29,414	507	26,414	25,018	37,656	649

Performance Data: Sensible capacity at specific conditions

PHYSICAL, SOUND, ELECTRICAL DATA: 2 FAN MODELS

Model No. AGHN 2	Coil				Unit		Electrical Defrost			
	Face Area ft ²	Surface Area ft ²	Tube Volume ft ³	Fin Spacing fpi	Sound Pressure Level dB(A)	Air Throw ft	Total kW	Coil W	Tray W	AMP DRAWS @ 3/460 ** A
050.2D/24-	15	1,447	0.719	6.3	68	69	9.40	7,000	2,400	11.8
050.2E/24-	15	1,809	0.848		68	69	11.15	8,750	2,400	14.0
050.2F/24-	15	2,171	1.079		68	66	14.10	10,500	3,600	17.7
071.2D/24-	26	2,531	1.227		66	115	17.00	12,500	4,500	21.3
071.2E/24-	26	3,164	1.534		66	115	19.50	15,000	4,500	24.5
071.2F/24-	26	3,797	1.841		66	112	22.00	17,500	4,500	27.6
080.2D/24-	41	3,970	1.905		71	128	24.00	18,000	6,000	30.1
080.2E/24-	41	4,963	2.381		71	138	30.00	24,000	6,000	37.7
080.2F/24-	41	5,955	2.857		71	135	33.00	27,000	6,000	41.4
090.2E/24-	58	6,979	3.326		70	108	35.25	28,800	6,450	44.2
090.2F/24-	58	8,375	3.992	70	105	44.85	38,400	6,450	56.3	
050.2E/26-	15	1,231	0.874	4.2	68	69	11.15	8,750	2,400	14.0
050.2F/26-	15	1,477	1.079		68	66	14.10	10,500	3,600	17.7
050.2H/26-	15	1,969	1.439		68	69	19.35	15,750	3,600	24.3
071.2E/26-	26	2,152	1.534		66	115	19.50	15,000	4,500	24.5
071.2F/26-	26	2,582	1.841		66	112	22.00	17,500	4,500	27.6
071.2H/26-	26	3,443	2.454		66	115	27.00	22,500	4,500	33.9
080.2E/26-	41	3,376	2.381		71	138	30.00	24,000	6,000	37.7
080.2F/26-	41	4,051	2.857		71	135	33.00	27,000	6,000	41.4
080.2H/26-	41	5,401	3.810		71	138	42.00	36,000	6,000	52.7
090.2F/26-	58	5,696	3.992		70	105	44.85	38,400	6,450	56.3
090.2H/26-	58	7,595	5.322	70	105	56.60	48,000	8,600	71.0	
050.2D/28-	15	752	0.719	3.2	68	69	9.40	7,000	2,400	11.8
050.2E/28-	15	940	0.848		68	69	11.15	8,750	2,400	14.0
050.2F/28-	15	1,129	1.079		68	66	14.10	10,500	3,600	17.7
050.2H/28-	15	1,505	1.439		68	69	19.35	15,750	3,600	24.3
071.2E/28-	26	1,644	1.534		66	115	19.50	15,000	4,500	24.5
071.2F/28-	26	1,973	1.841		66	112	22.00	17,500	4,500	27.6
071.2H/28-	26	2,631	2.454		66	115	27.00	22,500	4,500	33.9
080.2E/28-	41	2,579	2.381		71	138	30.00	24,000	6,000	37.7
080.2F/28-	41	3,095	2.857		71	135	33.00	27,000	6,000	41.4
080.2H/28-	41	4,127	3.810		71	138	42.00	36,000	6,000	52.7
090.2F/28-	58	4,353	3.992		70	105	44.85	38,400	6,450	56.3
090.2H/28-	58	5,804	5.322		70	105	56.60	48,000	8,600	71.0

* First 2 rows on air inlet side have wider fin spacing

** Units with heater amp draws greater than 48 amps will be supplied with multiple circuits as required by the NEC

PHYSICAL, SOUND, ELECTRICAL DATA: 2 FAN MODELS

Model No. AGHN 2	Coil			Fin Spacing fpi	Unit		Electrical Defrost			AMP DRAWS @ 3/460 ** A
	Face Area ft ²	Surface Area ft ²	Tube Volume ft ³		Sound Pressure Level dB(A)	Air Throw ft	Total kW	Coil W	Tray W	
050.2D/210-	15	614	0.719	2.5	68	69	9.40	7,000	2,400	11.8
050.2E/210-	15	767	0.848		68	69	11.15	8,750	2,400	14.0
050.2F/210-	15	920	1.079		68	66	14.10	10,500	3,600	17.7
050.2H/210-	15	1,227	1.439		68	69	19.35	15,750	3,600	24.3
071.2E/210-	26	1,341	1.534		66	115	19.50	15,000	4,500	24.5
071.2F/210-	26	1,609	1.841		66	112	22.00	17,500	4,500	27.6
071.2H/210-	26	2,146	2.454		66	115	27.00	22,500	4,500	33.9
080.2F/210-	41	2,525	2.857		71	135	33.00	27,000	6,000	41.4
080.2H/210-	41	3,366	3.810		71	138	42.00	36,000	6,000	52.7
090.2F/210-	58	3,550	3.992		70	105	44.85	38,400	6,450	56.3
090.2H/210-	58	4,734	5.322		70	105	56.60	48,000	8,600	71.0
050.2D/212-	15	521	0.719	2.1	68	69	9.40	7,000	2,400	11.8
050.2E/212-	15	651	0.848		68	69	11.15	8,750	2,400	14.0
050.2F/212-	15	782	1.079		68	66	14.10	10,500	3,600	17.7
050.2H/212-	15	1,042	1.439		68	69	19.35	15,750	3,600	24.3
071.2E/212-	26	1,139	1.534		66	115	19.50	15,000	4,500	24.5
071.2F/212-	26	1,367	1.841		66	112	22.00	17,500	4,500	27.6
071.2H/212-	26	1,822	2.454		66	115	27.00	22,500	4,500	33.9
080.2F/212-	41	2,144	2.857		71	135	33.00	27,000	6,000	41.4
080.2H/212-	41	2,859	3.810		71	138	42.00	36,000	6,000	52.7
090.2F/212-	58	3,015	3.992		70	105	44.85	38,400	6,450	56.3
090.2H/212-	58	4,020	5.322		70	105	56.60	48,000	8,600	71.0
050.2F/2A-	15	956	1.081	1.6 - 3.2*	68	66	14.10	10,500	3,600	17.7
050.2H/2A-	15	1,332	1.437		68	69	19.35	15,750	3,600	24.3
071.2F/2A-	26	1,671	1.840		66	112	22.00	17,500	4,500	27.6
071.2H/2A-	26	2,329	2.454		66	115	27.00	22,500	4,500	33.9
080.2F/2A-	41	2,621	2.857		71	135	33.00	27,000	6,000	41.4
080.2H/2A-	41	3,653	3.810		71	138	42.00	36,000	6,000	52.7
090.2F/2A-	58	3,686	3.991		70	105	44.85	38,400	6,450	56.3
090.2H/2A-	58	5,138	5.322		70	105	56.60	48,000	8,600	71.0
050.2F/2B-	15	782	1.081		1.25 - 2.5*	68	66	14.10	10,500	3,600
050.2H/2B-	15	1,089	1.437	68		69	19.35	15,750	3,600	24.3
071.2F/2B-	26	1,368	1.840	66		112	22.00	17,500	4,500	27.6
071.2H/2B-	26	1,904	2.454	66		115	27.00	22,500	4,500	33.9
080.2F/2B-	41	2,145	2.857	71		135	33.00	27,000	6,000	41.4
080.2H/2B-	41	2,987	3.810	71		138	42.00	36,000	6,000	52.7
090.2F/2B-	58	3,017	3.991	70		105	44.85	38,400	6,450	56.3
090.2H/2B-	58	4,201	5.322	70		105	56.60	48,000	8,600	71.0

* First 2 rows on air inlet side have wider fin spacing

** Units with heater amp draws greater than 48 amps will be supplied with multiple circuits as required by the NEC

PERFORMANCE DATA: 3 FAN MODELS

Model No. AGHN 2	Coil Capacity & Air Flow											
	ESP: 0 in H ₂ O				ESP: 1/4 in H ₂ O				ESP: 1/2 in H ₂ O			
	Wet	Frosted	Air Flow	Face Velocity	Wet	Frosted	Air Flow	Face Velocity	Wet	Frosted	Air Flow	Face Velocity
	Btu/hr °F TD	Btu/hr °F TD	cfm	fpm	Btu/hr °F TD	Btu/hr °F TD	cfm	fpm	Btu/hr °F TD	Btu/hr °F TD	cfm	fpm
050.2D/34-	8,145	7,355	11,887	517	8,063	7,296	11,569	503	8,727	7,760	14,377	625
050.2E/34-	10,153	9,200	11,575	503	10,025	9,110	11,216	488	10,916	9,768	13,971	607
050.2F/34-	11,995	11,065	11,351	494	11,783	10,900	10,898	474	12,961	11,807	13,671	594
071.2D/34-	14,225	12,825	20,235	506	13,982	12,620	19,305	483	15,262	12,990	24,745	619
071.2E/34-	17,430	15,971	19,458	486	17,143	15,760	18,687	467	18,941	17,048	24,056	601
071.2F/34-	20,632	18,190	18,758	469	20,290	17,972	18,051	451	22,593	19,395	23,420	586
080.2D/34-	22,134	20,223	31,740	512	22,134	20,223	31,740	512	23,858	21,688	40,041	646
080.2E/34-	27,687	25,220	30,644	494	27,731	25,254	30,768	496	30,320	27,240	39,069	630
080.2F/34-	32,866	30,345	31,133	502	32,343	29,908	29,903	482	35,530	32,517	38,222	616
090.2E/34-	38,612	35,087	42,408	487	38,612	35,087	42,408	487	42,321	38,330	54,771	630
090.2F/34-	45,352	41,520	41,201	474	45,354	41,522	41,207	474	50,261	45,758	53,570	616
050.2D/36-	7,936	7,716	12,152	528	7,829	7,616	11,710	509	8,442	8,197	14,466	629
050.2F/36-	9,699	9,424	11,928	519	9,554	9,288	11,445	498	10,322	10,017	14,236	619
050.2H/36-	13,141	12,762	11,439	497	12,910	12,534	10,898	474	14,010	13,575	13,671	594
071.2E/36-	14,423	14,053	20,547	514	14,212	13,853	19,694	492	15,428	15,003	25,063	627
071.2F/36-	17,589	17,130	20,082	502	17,289	16,854	19,146	479	18,819	18,290	24,516	613
071.2H/36-	23,819	23,182	18,987	475	23,451	22,835	18,139	453	25,415	24,688	23,350	584
080.2E/36-	21,895	21,320	32,110	518	21,895	21,320	32,110	518	23,787	23,086	40,535	654
080.2F/36-	27,289	26,560	31,498	508	27,250	26,525	31,369	506	29,517	28,657	39,670	640
080.2H/36-	34,885	33,889	30,032	484	34,883	33,886	30,026	484	38,019	36,827	38,098	614
090.2F/36-	37,948	36,933	43,609	501	37,840	36,831	43,255	497	40,804	39,703	53,906	620
090.2H/36-	51,297	49,905	41,377	476	51,300	49,907	41,383	476	56,040	54,441	53,570	616
050.2D/38-	5,273	5,000	12,593	548	5,204	4,941	12,205	531	5,664	5,328	14,960	650
050.2E/38-	6,702	6,351	12,376	538	6,596	6,261	11,922	518	7,211	6,775	14,731	640
050.2F/38-	8,155	7,728	12,193	530	8,012	7,608	11,710	509	8,788	8,251	14,519	631
050.2H/38-	10,839	10,318	11,793	513	10,610	10,127	11,269	490	11,713	11,036	13,971	607
071.2E/38-	11,538	10,983	21,089	527	11,314	10,792	20,153	504	12,538	11,830	25,681	642
071.2F/38-	14,333	13,328	20,624	516	14,048	13,103	19,694	492	15,586	14,292	25,134	628
071.2H/38-	18,897	17,678	19,688	492	18,503	17,368	18,828	471	20,703	19,060	24,056	601
080.2E/38-	17,819	17,061	32,717	528	17,818	17,060	32,711	528	19,657	18,649	41,260	665
080.2F/38-	21,680	20,768	32,228	520	21,682	20,769	32,234	520	23,966	22,728	40,659	656
080.2H/38-	28,783	27,705	31,133	502	28,676	27,613	30,892	498	31,956	30,409	39,069	630
090.2F/38-	31,663	28,950	44,810	515	31,508	28,834	44,298	509	34,957	31,329	56,820	653
090.2H/38-	40,858	38,941	42,920	493	40,705	38,814	42,584	489	45,702	42,896	54,771	630
050.2D/310-	4,466	4,276	12,464	542	4,445	4,257	12,328	536	4,844	4,606	15,084	656
050.2E/310-	5,609	5,372	12,287	534	5,581	5,348	12,152	528	6,095	5,796	14,907	648
050.2F/310-	6,889	6,593	12,193	530	6,820	6,533	11,922	518	7,478	7,102	14,731	640
050.2H/310-	9,307	8,925	11,887	517	9,178	8,814	11,534	501	10,094	9,599	14,218	618
071.2E/310-	10,151	9,312	21,171	529	10,015	9,185	20,471	512	11,015	10,115	26,070	652
071.2F/310-	12,236	11,548	21,012	525	12,013	11,363	20,153	504	13,340	12,450	25,681	642
071.2H/310-	16,393	15,512	20,159	504	16,068	15,243	19,305	483	17,926	16,756	24,586	615
080.2F/310-	18,411	17,738	32,717	528	18,410	17,737	32,711	528	20,372	19,477	41,260	665
080.2H/310-	24,778	23,936	31,622	510	24,775	23,934	31,616	510	27,510	26,340	39,794	642
090.2F/310-	27,092	25,250	45,669	525	26,869	25,072	44,810	515	29,885	27,426	57,509	661
090.2H/310-	35,372	33,931	43,950	505	35,177	33,762	43,432	499	39,415	37,375	55,796	641
050.2D/312-	4,021	3,790	12,593	548	4,004	3,774	12,464	542	4,357	4,093	15,225	662
050.2E/312-	4,921	4,737	12,464	542	4,898	4,716	12,328	536	5,350	5,120	15,084	656
050.2F/312-	6,041	5,811	12,376	538	5,992	5,766	12,152	528	6,567	6,277	14,960	650
050.2H/312-	8,218	7,913	12,016	522	8,150	7,852	11,799	513	8,953	8,558	14,519	631
071.2E/312-	9,051	8,252	21,790	545	8,888	7,947	20,859	521	9,809	8,949	26,547	664
071.2F/312-	10,779	10,261	21,478	537	10,567	10,079	20,541	514	11,747	11,084	26,158	654
071.2H/312-	14,578	13,893	20,624	516	14,295	13,652	19,764	494	15,936	15,034	25,134	628
080.2F/312-	16,131	15,586	33,206	536	16,131	15,586	33,206	536	17,873	17,163	41,878	675
080.2H/312-	21,908	21,200	32,110	518	21,946	21,235	32,234	520	24,387	23,425	40,659	656
090.2F/312-	23,858	22,502	46,523	535	23,624	22,307	45,499	523	26,290	24,489	58,198	669
090.2H/312-	31,418	30,253	44,981	517	31,197	30,057	44,298	509	34,926	33,319	56,820	653
050.2F/3A-	8,182	7,751	12,287	534	8,065	7,652	11,887	517	8,833	8,287	14,695	639
050.2H/3A-	10,879	10,352	11,887	517	10,688	10,193	11,445	498	11,779	11,089	14,148	615
071.2F/3A-	14,404	1,383	20,859	521	14,168	13,199	20,082	502	15,685	14,366	25,522	638
071.2H/3A-	18,969	17,734	19,847	496	18,618	17,459	19,076	477	20,816	19,146	24,357	609
080.2F/3A-	21,753	20,831	32,475	524	21,791	20,864	32,605	526	24,083	22,827	41,136	663

Performance Data: Sensible capacity at specific conditions

PERFORMANCE DATA: 3 FAN MODELS

Model No. AGHN 2	Coil Capacity & Air Flow											
	ESP: 0 in H ₂ O				ESP: 1/4 in H ₂ O				ESP: 1/2 in H ₂ O			
	Wet	Frosted	Air Flow	Face Velocity	Wet	Frosted	Air Flow	Face Velocity	Wet	Frosted	Air Flow	Face Velocity
	Btu/hr /°F TD	Btu/hr /°F TD	cfm	fpm	Btu/hr /°F TD	Btu/hr /°F TD	cfm	fpm	Btu/hr /°F TD	Btu/hr /°F TD	cfm	fpm
080.2H/3A-	28,834	27,749	31,251	504	28,878	27,787	31,351	506	32,091	30,523	39,440	636
090.2F/3A-	31,870	29,102	45,493	523	31,612	28,911	44,639	513	35,088	31,421	57,350	659
090.2H/3A-	41,088	39,133	43,432	499	40,938	39,007	43,097	495	45,891	43,047	55,284	635
050.2F/3B-	6,934	6,632	12,376	538	6,878	6,584	12,152	528	7,528	7,144	14,960	650
050.2H/3B-	9,386	8,993	12,105	526	9,243	8,870	11,710	509	10,171	9,664	14,466	629
071.2F/3B-	12,354	11,645	21,478	537	12,809	12,020	23,350	584	13,444	12,534	26,158	654
071.2H/3B-	16,479	15,582	20,388	510	17,203	16,174	22,414	560	18,079	16,876	25,063	627
080.2F/3B-	18,533	17,847	33,206	536	18,533	17,847	33,206	536	20,502	19,591	41,878	675
080.2H/3B-	24,865	24,014	31,863	514	24,955	24,094	32,110	518	27,698	26,504	40,412	652
090.2F/3B-	27,311	25,424	46,523	535	27,048	25,215	45,499	523	30,034	27,539	58,198	669
090.2H/3B-	35,628	34,152	44,639	513	35,436	33,986	44,121	507	39,629	37,555	56,485	649

Performance Data: Sensible capacity at specific conditions

PHYSICAL, SOUND, ELECTRICAL DATA: 3 FAN MODELS

Model No. AGHN 2	Coil				Unit		Electrical Defrost			
	Face Area ft ²	Surface Area ft ²	Tube Volume ft ³	Fin Spacing fpi	Sound Pressure Level dB(A)	Air Throw ft	Total kW	Coil W	Tray W	AMP DRAWS @ 3/460 ** A
050.2D/34-	23	2,171	1.046	6.3	69	72	12.8	9,600	3,200	16.1
050.2E/34-	23	2,714	1.233		69	72	15.2	12,000	3,200	19.1
050.2F/34-	23	3,257	1.569		69	69	19.2	14,400	4,800	24.1
071.2D/34-	40	3,797	1.798		67	121	25.3	19,000	6,300	31.8
071.2E/34-	40	4,746	2.248		67	121	29.1	22,800	6,300	36.5
071.2F/34-	40	5,695	2.697		67	118	32.9	26,600	6,300	41.3
080.2D/34-	62	5,955	2.801		72	148	35.7	27,000	8,700	44.8
080.2E/34-	62	7,444	3.501		72	144	44.7	36,000	8,700	56.1
080.2F/34-	62	8,933	4.201		72	141	49.2	40,500	8,700	61.8
090.2E/34-	87	10,469	4.901		72	115	58.20	48,600	9,600	73.0
090.2F/34-	87	12,562	5.881	72	112	74.40	64,800	9,600	93.4	
050.2E/36-	23	1,846	1.233	4.2	69	72	15.20	12,000	3,200	19.1
050.2F/36-	23	2,215	1.569		69	69	19.20	14,400	4,800	24.1
050.2H/36-	23	2,954	2.092		69	72	26.40	21,600	4,800	33.1
071.2E/36-	40	3,228	2.248		67	121	29.10	22,800	6,300	36.5
071.2F/36-	40	3,874	2.697		67	118	32.90	26,600	6,300	41.3
071.2H/36-	40	5,165	3.596		67	121	40.50	34,200	6,300	50.8
080.2E/36-	62	5,063	3.501		72	144	44.70	36,000	8,700	56.1
080.2F/36-	62	6,076	4.201		72	141	49.20	40,500	8,700	61.8
080.2H/36-	62	8,102	5.601		72	144	62.70	54,000	8,700	78.7
090.2F/36-	87	8,545	5.881		72	112	74.40	64,800	9,600	93.4
090.2H/36-	87	11,393	7.841	72	112	93.80	81,000	12,800	117.7	
050.2D/38-	23	1,129	1.046	3.2	69	72	12.80	9,600	3,200	16.1
050.2E/38-	23	1,411	1.307		69	72	15.20	12,000	3,200	19.1
050.2F/38-	23	1,693	1.569		69	69	19.20	14,400	4,800	24.1
050.2H/38-	23	2,257	2.092		69	72	26.40	21,600	4,800	33.1
071.2E/38-	40	2,467	2.248		67	121	29.10	22,800	6,300	36.5
071.2F/38-	40	2,960	2.697		67	118	32.90	26,600	6,300	41.3
071.2H/38-	40	3,947	3.596		67	121	40.50	34,200	6,300	50.8
080.2E/38-	62	3,869	3.501		72	144	44.70	36,000	8,700	56.1
080.2F/38-	62	4,643	4.201		72	141	49.20	40,500	8,700	61.8
080.2H/38-	62	6,191	5.601		72	144	62.70	54,000	8,700	78.7
090.2F/38-	87	6,529	5.881	72	112	74.40	64,800	9,600	93.4	
090.2H/38-	87	8,706	7.841	72	112	93.80	81,000	12,800	117.7	

* First 2 rows on air inlet side have wider fin spacing

** Units with heater amp draws greater than 48 amps will be supplied with multiple circuits as required by the NEC

PHYSICAL, SOUND, ELECTRICAL DATA: 3 FAN MODELS

Model No. AGHN 2	Coil				Unit		Electrical Defrost				
	Face Area ft ²	Surface Area ft ²	Tube Volume ft ³	Fin Spacing fpi	Sound Pressure Level dB(A)	Air Throw ft	Total kW	Coil W	Tray W	AMP DRAWS @ 3/460 ** A	
050.2D/310-	23	920	1.046	2.5	69	72	12.80	9,600	3,200	16.1	
050.2E/310-	23	1,151	1.307		69	72	15.20	12,000	3,200	19.1	
050.2F/310-	23	1,381	1.569		69	69	19.20	14,400	4,800	24.1	
050.2H/310-	23	1,841	2.092		69	72	26.40	21,600	4,800	33.1	
071.2E/310-	40	2,012	2.248		67	121	29.10	22,800	6,300	36.5	
071.2F/310-	40	2,414	2.697		67	118	32.90	26,600	6,300	41.3	
071.2H/310-	40	3,219	3.596		67	121	40.50	34,200	6,300	50.8	
080.2F/310-	62	3,787	4.201		72	141	49.20	40,500	8,700	61.8	
080.2H/310-	62	5,049	5.601		72	144	62.70	54,000	8,700	78.7	
090.2F/310-	87	5,325	5.881		72	112	74.40	64,800	9,600	93.4	
090.2H/310-	87	7,100	7.841		72	112	93.80	81,000	12,800	117.7	
050.2D/312-	23	782	1.009	2.1	69	72	12.80	9,600	3,200	16.1	
050.2E/312-	23	977	1.307		69	72	15.20	12,000	3,200	19.1	
050.2F/312-	23	1,173	1.569		69	69	19.20	14,400	4,800	24.1	
050.2H/312-	23	1,563	2.092		69	72	26.40	21,600	4,800	33.1	
071.2E/312-	40	1,709	2.248		67	121	29.10	22,800	6,300	36.5	
071.2F/312-	40	2,050	2.697		67	118	32.90	26,600	6,300	41.3	
071.2H/312-	40	2,734	3.596		67	121	40.50	34,200	6,300	50.8	
080.2F/312-	62	3,216	4.201		72	141	49.20	40,500	8,700	61.8	
080.2H/312-	62	4,288	5.601		72	144	62.70	54,000	8,700	78.7	
090.2F/312-	87	4,523	5.881		72	112	74.40	64,800	9,600	93.4	
090.2H/312-	87	6,030	7.841		72	112	93.80	81,000	12,800	117.7	
050.2F/3A-	23	1,433	1.568	1.6 - 3.2*	69	69	19.20	14,400	4,800	24.1	
050.2H/3A-	23	1,998	2.091		69	72	26.40	21,600	4,800	33.1	
071.2F/3A-	40	2,506	2.698		67	118	32.90	26,600	6,300	41.3	
071.2H/3A-	40	3,494	3.599		67	121	40.50	34,200	6,300	50.8	
080.2F/3A-	62	3,932	4.202		72	141	49.20	40,500	8,700	61.8	
080.2H/3A-	62	5,480	5.601		72	144	62.70	54,000	8,700	78.7	
090.2F/3A-	87	5,529	5.880		72	112	74.40	64,800	9,600	93.4	
090.2H/3A-	87	7,706	7.843		72	112	93.80	81,000	12,800	117.7	
050.2F/3B-	23	1,173	1.568		1.25 - 2.5*	69	69	19.20	14,400	4,800	24.1
050.2H/3B-	23	1,634	2.091			69	72	26.40	21,600	4,800	33.1
071.2F/3B-	40	2,051	2.599	67		118	32.90	26,600	6,300	41.3	
071.2H/3B-	40	2,856	3.599	67		121	40.50	34,200	6,300	50.8	
080.2F/3B-	62	3,218	4.202	72		141	49.20	40,500	8,700	61.8	
080.2H/3B-	62	4,481	5.604	72		144	62.70	54,000	8,700	78.7	
090.2F/3B-	87	4,525	5.880	72		112	74.40	64,800	9,600	93.4	
090.2H/3B-	87	6,301	7.843	72		112	93.80	81,000	12,800	117.7	

* First 2 rows on air inlet side have wider fin spacing

** Units with heater amp draws greater than 48 amps will be supplied with multiple circuits as required by the NEC

PERFORMANCE DATA: 4 FAN MODELS

Model No. AGHN 2	Coil Capacity & Air Flow											
	ESP: 0 in H ₂ O				ESP: 1/4 in H ₂ O				ESP: 1/2 in H ₂ O			
	Wet	Frosted	Air Flow	Face Velocity	Wet	Frosted	Air Flow	Face Velocity	Wet	Frosted	Air Flow	Face Velocity
	Btu/hr °F TD	Btu/hr °F TD	cfm	fpm	Btu/hr °F TD	Btu/hr °F TD	cfm	fpm	Btu/hr °F TD	Btu/hr °F TD	cfm	fpm
050.2D/34-	8,145	7,355	11,887	517	8,063	7,296	11,569	503	8,727	7,760	14,377	625
050.2E/34-	10,153	9,200	11,575	503	10,025	9,110	11,216	488	10,916	9,768	13,971	607
050.2F/34-	11,995	11,065	11,351	494	11,783	10,900	10,898	474	12,961	11,807	13,671	594
071.2D/34-	14,225	12,825	20,235	506	13,982	12,620	19,305	483	15,262	12,990	24,745	619
071.2E/34-	17,430	15,971	19,458	486	17,143	15,760	18,687	467	18,941	17,048	24,056	601
071.2F/34-	20,632	18,190	18,758	469	20,290	17,972	18,051	451	22,593	19,395	23,420	586
080.2D/34-	22,134	20,223	31,740	512	22,134	20,223	31,740	512	23,858	21,688	40,041	646
080.2E/34-	27,687	25,220	30,644	494	27,731	25,254	30,768	496	30,320	27,240	39,069	630
080.2F/34-	32,866	30,345	31,133	502	32,343	29,908	29,903	482	35,530	32,517	38,222	616
090.2E/34-	38,612	35,087	42,408	487	38,612	35,087	42,408	487	42,321	38,330	54,771	630
090.2F/34-	45,352	41,520	41,201	474	45,354	41,522	41,207	474	50,261	45,758	53,570	616
050.2E/36-	7,936	7,716	12,152	528	7,829	7,616	11,710	509	8,442	8,197	14,466	629
050.2F/36-	9,699	9,424	11,928	519	9,554	9,288	11,445	498	10,322	10,017	14,236	619
050.2H/36-	13,141	12,762	11,439	497	12,910	12,534	10,898	474	14,010	13,575	13,671	594
071.2E/36-	14,423	14,053	20,547	514	14,212	13,853	19,694	492	15,428	15,003	25,063	627
071.2F/36-	17,589	17,130	20,082	502	17,289	16,854	19,146	479	18,819	18,290	24,516	613
071.2H/36-	23,819	23,182	18,987	475	23,451	22,835	18,139	453	25,415	24,688	23,350	584
080.2E/36-	21,895	21,320	32,110	518	21,895	21,320	32,110	518	23,787	23,086	40,535	654
080.2F/36-	27,289	26,560	31,498	508	27,250	26,525	31,369	506	29,517	28,657	39,670	640
080.2H/36-	34,885	33,889	30,032	484	34,883	33,886	30,026	484	38,019	36,827	38,098	614
090.2F/36-	37,948	36,933	43,609	501	37,840	36,831	43,255	497	40,804	39,703	53,906	620
090.2H/36-	51,297	49,905	41,377	476	51,300	49,907	41,383	476	56,040	54,441	53,570	616
050.2D/38-	5,273	5,000	12,593	548	5,204	4,941	12,205	531	5,664	5,328	14,960	650
050.2E/38-	6,702	6,351	12,376	538	6,596	6,261	11,922	518	7,211	6,775	14,731	640
050.2F/38-	8,155	7,728	12,193	530	8,012	7,608	11,710	509	8,788	8,251	14,519	631
050.2H/38-	10,839	10,318	11,793	513	10,610	10,127	11,269	490	11,713	11,036	13,971	607
071.2E/38-	11,538	10,983	21,089	527	11,314	10,792	20,153	504	12,538	11,830	25,681	642
071.2F/38-	14,333	13,328	20,624	516	14,048	13,103	19,694	492	15,586	14,292	25,134	628
071.2H/38-	18,897	17,678	19,688	492	18,503	17,368	18,828	471	20,703	19,060	24,056	601
080.2E/38-	17,819	17,061	32,717	528	17,818	17,060	32,711	528	19,657	18,649	41,260	665
080.2F/38-	21,680	20,768	32,228	520	21,682	20,769	32,234	520	23,966	22,728	40,659	656
080.2H/38-	28,783	27,705	31,133	502	28,676	27,613	30,892	498	31,956	30,409	39,069	630
090.2F/38-	31,663	28,950	44,810	515	31,508	28,834	44,298	509	34,957	31,329	56,820	653
090.2H/38-	40,858	38,941	42,920	493	40,705	38,814	42,584	489	45,702	42,896	54,771	630
050.2D/310-	4,466	4,276	12,464	542	4,445	4,257	12,328	536	4,844	4,606	15,084	656
050.2E/310-	5,609	5,372	12,287	534	5,581	5,348	12,152	528	6,095	5,796	14,907	648
050.2F/310-	6,889	6,593	12,193	530	6,820	6,533	11,922	518	7,478	7,102	14,731	640
050.2H/310-	9,307	8,925	11,887	517	9,178	8,814	11,534	501	10,094	9,599	14,218	618
071.2E/310-	10,151	9,312	21,171	529	10,015	9,185	20,471	512	11,015	10,115	26,070	652
071.2F/310-	12,236	11,548	21,012	525	12,013	11,363	20,153	504	13,340	12,450	25,681	642
071.2H/310-	16,393	15,512	20,159	504	16,068	15,243	19,305	483	17,926	16,756	24,586	615
080.2F/310-	18,411	17,738	32,717	528	18,410	17,737	32,711	528	20,372	19,477	41,260	665
080.2H/310-	24,778	23,936	31,622	510	24,775	23,934	31,616	510	27,510	26,340	39,794	642
090.2F/310-	27,092	25,250	45,669	525	26,869	25,072	44,810	515	29,885	27,426	57,509	661
090.2H/310-	35,372	33,931	43,950	505	35,177	33,762	43,432	499	39,415	37,375	55,796	641
050.2D/312-	4,021	3,790	12,593	548	4,004	3,774	12,464	542	4,357	4,093	15,225	662
050.2E/312-	4,921	4,737	12,464	542	4,898	4,716	12,328	536	5,350	5,120	15,084	656
050.2F/312-	6,041	5,811	12,376	538	5,992	5,766	12,152	528	6,567	6,277	14,960	650
050.2H/312-	8,218	7,913	12,016	522	8,150	7,852	11,799	513	8,953	8,558	14,519	631
071.2E/312-	9,051	8,252	21,790	545	8,888	7,947	20,859	521	9,809	8,949	26,547	664
071.2F/312-	10,779	10,261	21,478	537	10,567	10,079	20,541	514	11,747	11,084	26,158	654
071.2H/312-	14,578	13,893	20,624	516	14,295	13,652	19,764	494	15,936	15,034	25,134	628
080.2F/312-	16,131	15,586	33,206	536	16,131	15,586	33,206	536	17,873	17,163	41,878	675
080.2H/312-	21,908	21,200	32,110	518	21,946	21,235	32,234	520	24,387	23,425	40,659	656
090.2F/312-	23,858	22,502	46,523	535	23,624	22,307	45,499	523	26,290	24,489	58,198	669
090.2H/312-	31,418	30,253	44,981	517	31,197	30,057	44,298	509	34,926	33,319	56,820	653
050.2F/3A-	8,182	7,751	12,287	534	8,065	7,652	11,887	517	8,833	8,287	14,695	639
050.2H/3A-	10,879	10,352	11,887	517	10,688	10,193	11,445	498	11,779	11,089	14,148	615
071.2F/3A-	14,404	1,383	20,859	521	14,168	13,199	20,082	502	15,685	14,366	25,522	638
071.2H/3A-	18,969	17,734	19,847	496	18,618	17,459	19,076	477	20,816	19,146	24,357	609
080.2F/3A-	21,753	20,831	32,475	524	21,791	20,864	32,605	526	24,083	22,827	41,136	663

Performance Data: Sensible capacity at specific conditions

PERFORMANCE DATA: 4 FAN MODELS

Model No. AGHN 2	Coil Capacity & Air Flow											
	ESP: 0 in H ₂ O				ESP: 1/4 in H ₂ O				ESP: 1/2 in H ₂ O			
	Wet	Frosted	Air Flow	Face Velocity	Wet	Frosted	Air Flow	Face Velocity	Wet	Frosted	Air Flow	Face Velocity
	Btu/hr °F TD	Btu/hr °F TD	cfm	fpm	Btu/hr °F TD	Btu/hr °F TD	cfm	fpm	Btu/hr °F TD	Btu/hr °F TD	cfm	fpm
080.2H/3A-	28,834	27,749	31,251	504	28,878	27,787	31,351	506	32,091	30,523	39,440	636
090.2F/3A-	31,870	29,102	45,493	523	31,612	28,911	44,639	513	35,088	31,421	57,350	659
090.2H/3A-	41,088	39,133	43,432	499	40,938	39,007	43,097	495	45,891	43,047	55,284	635
050.2F/3B-	6,934	6,632	12,376	538	6,878	6,584	12,152	528	7,528	7,144	14,960	650
050.2H/3B-	9,386	8,993	12,105	526	9,243	8,870	11,710	509	10,171	9,664	14,466	629
071.2F/3B-	12,354	11,645	21,478	537	12,809	12,020	23,350	584	13,444	12,534	26,158	654
071.2H/3B-	16,479	15,582	20,388	510	17,203	16,174	22,414	560	18,079	16,876	25,063	627
080.2F/3B-	18,533	17,847	33,206	536	18,533	17,847	33,206	536	20,502	19,591	41,878	675
080.2H/3B-	24,865	24,014	31,863	514	24,955	24,094	32,110	518	27,698	26,504	40,412	652
090.2F/3B-	27,311	25,424	46,523	535	27,048	25,215	45,499	523	30,034	27,539	58,198	669
090.2H/3B-	35,628	34,152	44,639	513	35,436	33,986	44,121	507	39,629	37,555	56,485	649

Performance Data: Sensible capacity at specific conditions

PHYSICAL, SOUND, ELECTRICAL DATA: 4 FAN MODELS

Model No. AGHN 2	Coil				Unit		Electrical Defrost			
	Face Area ft ²	Surface Area ft ²	Tube Volume ft ³	Fin Spacing fpi	Sound Pressure Level dB(A)	Air Throw ft	Total kW	Coil W	Tray W	AMP DRAWS @ 3/460 ** A
050.2D/44-	30	2,895	1.372	6.3	70	75	17.6	14,000	3,600	22.1
050.2E/44-	30	3,619	1.716		70	75	21.1	17,500	3,600	26.5
050.2F/44-	30	4,343	2.059		70	72	26.4	21,000	5,400	33.1
071.2D/44-	53	5,062	2.369		68	125	35.7	27,000	8,700	44.8
071.2E/44-	53	6,328	2.961		68	125	41.1	32,400	8,700	51.6
071.2F/44-	53	7,593	3.554		68	121	46.5	37,800	8,700	58.4
080.2D/44-	83	7,941	3.696		73	154	46.2	36,000	10,200	58.0
080.2E/44-	83	9,926	4.620		73	154	58.2	48,000	10,200	73.0
080.2F/44-	83	11,911	5.544		73	151	64.2	54,000	10,200	80.6
090.2E/44-	116	13,958	6.475		72	118	76.20	64,800	11,400	95.6
090.2F/44-	116	16,750	7.770	72	115	97.80	86,400	11,400	122.7	
050.2E/46-	30	2,461	1.716	4.2	70	75	21.10	17,500	3,600	26.5
050.2F/46-	30	2,954	2.059		70	72	26.40	21,000	5,400	33.1
050.2H/46-	30	3,938	2.745		70	75	36.90	31,500	5,400	46.3
071.2E/46-	53	4,304	2.961		68	125	35.70	27,000	8,700	44.8
071.2F/46-	53	5,165	3.554		68	125	41.10	32,400	8,700	51.6
071.2H/46-	53	6,886	4.738		68	121	46.50	37,800	8,700	58.4
080.2E/46-	83	6,751	4.620		73	154	46.20	36,000	10,200	58.0
080.2F/46-	83	8,102	5.544		73	154	58.20	48,000	10,200	73.0
080.2H/46-	83	10,802	7.392		73	151	64.20	54,000	10,200	80.6
090.2F/46-	116	11,393	7.770		72	118	76.20	64,800	11,400	95.6
090.2H/46-	116	15,190	10.360	72	115	97.80	86,400	11,400	122.7	
050.2D/48-	30	1,505	1.372	3.2	70	75	17.60	14,000	3,600	22.1
050.2E/48-	30	1,881	1.716		70	75	21.10	17,500	3,600	26.5
050.2F/48-	30	2,257	2.059		70	72	26.40	21,000	5,400	33.1
050.2H/48-	30	3,009	2.745		70	75	36.90	31,500	5,400	46.3
071.2E/48-	53	3,289	2.961		68	125	35.70	27,000	8,700	44.8
071.2F/48-	53	3,947	3.554		68	125	41.10	32,400	8,700	51.6
071.2H/48-	53	5,262	4.738		68	121	46.50	37,800	8,700	58.4
080.2E/48-	83	5,159	4.620		73	154	46.20	36,000	10,200	58.0
080.2F/48-	83	6,191	5.544		73	154	58.20	48,000	10,200	73.0
080.2H/48-	83	8,254	7.392		73	151	64.20	54,000	10,200	80.6
090.2F/48-	116	8,706	7.770	72	118	76.20	64,800	11,400	95.6	
090.2H/48-	116	11,608	10.360	72	115	97.80	86,400	11,400	122.7	

* First 2 rows on air inlet side have wider fin spacing

** Units with heater amp draws greater than 48 amps will be supplied with multiple circuits as required by the NEC

PHYSICAL, SOUND, ELECTRICAL DATA: 4 FAN MODELS

Model No. AGHN 2	Coil				Unit		Electrical Defrost			
	Face Area ft ²	Surface Area ft ²	Tube Volume ft ³	Fin Spacing fpi	Sound Pressure Level dB(A)	Air Throw ft	Total kW	Coil W	Tray W	AMP DRAWS @ 3/460 ** A
050.2D/410-	30	1,227	1.372	2.5	70	75	17.60	14,000	3,600	22.1
050.2E/410-	30	1,534	1.716		70	75	21.10	17,500	3,600	26.5
050.2F/410-	30	1,841	2.059		70	72	26.40	21,000	5,400	33.1
050.2H/410-	30	2,454	2.745		70	75	36.90	31,500	5,400	46.3
071.2E/410-	53	2,682	2.961		68	125	35.70	27,000	8,700	44.8
071.2F/410-	53	3,219	3.554		68	125	41.10	32,400	8,700	51.6
071.2H/410-	53	4,292	4.738		68	121	46.50	37,800	8,700	58.4
080.2F/410-	83	5,049	5.544		73	154	58.20	48,000	10,200	73.0
080.2H/410-	83	6,732	7.392		73	151	64.20	54,000	10,200	80.6
090.2F/410-	116	7,100	7.597		72	118	76.20	64,800	11,400	95.6
090.2H/410-	116	9,467	10.360	72	115	97.80	86,400	11,400	122.7	
050.2D/412-	30	1,042	1.372	2.1	70	75	17.60	14,000	3,600	22.1
050.2E/412-	30	1,303	1.716		70	75	21.10	17,500	3,600	26.5
050.2F/412-	30	1,563	2.059		70	72	26.40	21,000	5,400	33.1
050.2H/412-	30	2,085	2.745		70	75	36.90	31,500	5,400	46.3
071.2E/412-	53	2,278	2.961		68	125	35.70	27,000	8,700	44.8
071.2F/412-	53	2,734	3.554		68	125	41.10	32,400	8,700	51.6
071.2H/412-	53	3,645	4.738		68	121	46.50	37,800	8,700	58.4
080.2F/412-	83	4,288	5.544		73	154	58.20	48,000	10,200	73.0
080.2H/412-	83	5,718	7.392		73	151	64.20	54,000	10,200	80.6
090.2F/412-	116	6,030	7.770		72	118	76.20	64,800	11,400	95.6
090.2H/412-	116	8,040	10.360	72	115	97.80	86,400	11,400	122.7	
050.2F/4A-	30	1,911	2.059	1.6 - 3.2*	70	72	26.40	21,000	5,400	33.1
050.2H/4A-	30	2,664	2.744		70	75	36.90	31,500	5,400	46.3
071.2F/4A-	53	3,342	3.553		68	125	41.10	32,400	8,700	51.6
071.2H/4A-	53	4,658	4.739		68	121	46.50	37,800	8,700	58.4
080.2F/4A-	83	5,242	5.544		73	154	58.20	48,000	10,200	73.0
080.2H/4A-	83	7,307	7.395		73	151	64.20	54,000	10,200	80.6
090.2F/4A-	116	7,372	7.773		72	118	76.20	64,800	11,400	95.6
090.2H/4A-	116	10,275	10.361		72	115	97.80	86,400	11,400	122.7
050.2F/4B-	30	1,564	2.059		1.25 - 2.5*	70	72	26.40	21,000	5,400
050.2H/4B-	30	2,178	2.744	70		75	36.90	31,500	5,400	46.3
071.2F/4B-	53	2,735	3.553	68		125	41.10	32,400	8,700	51.6
071.2H/4B-	53	3,809	4.739	68		121	46.50	37,800	8,700	58.4
080.2F/4B-	83	4,290	5.544	73		154	58.20	48,000	10,200	73.0
080.2H/4B-	83	5,974	7.395	73		151	64.20	54,000	10,200	80.6
090.2F/4B-	116	6,033	7.773	72		118	76.20	64,800	11,400	95.6
090.2H/4B-	116	8,401	10.361	72		115	97.80	86,400	11,400	122.7

* First 2 rows on air inlet side have wider fin spacing

** Units with heater amp draws greater than 48 amps will be supplied with multiple circuits as required by the NEC

DIMENSIONS: 1 FAN MODELS

Model No. AGHN	DIMENSIONS					CONNECTIONS				Dry Weight lb
	L inch	B inch	H inch	E inch	F inch	Refrigerant *		Hot Gas	Drain	
						IN inch	OUT inch	IN inch	K NPT	
050.2D/14-	57 $\frac{7}{8}$	25 $\frac{3}{8}$	29 $\frac{1}{2}$	39 $\frac{3}{8}$	21 $\frac{1}{2}$	1/2	*	1/2	1 $\frac{1}{4}$	207
050.2E/14-	57 $\frac{7}{8}$	25 $\frac{3}{8}$	29 $\frac{1}{2}$	39 $\frac{3}{8}$	21 $\frac{1}{2}$	1/2	*	1/2	1 $\frac{1}{4}$	227
050.2F/14-	57 $\frac{7}{8}$	32 $\frac{1}{2}$	29 $\frac{7}{8}$	39 $\frac{3}{8}$	27 $\frac{1}{2}$	1/2	*	1/2	1 $\frac{1}{4}$	258
071.2D/14-	82 $\frac{5}{8}$	35 $\frac{3}{8}$	37 $\frac{3}{8}$	53 $\frac{1}{2}$	28 $\frac{1}{8}$	1/2	*	1/2	2	459
071.2E/14-	82 $\frac{5}{8}$	35 $\frac{3}{8}$	37 $\frac{3}{8}$	53 $\frac{1}{2}$	28 $\frac{1}{8}$	1/2	*	1/2	2	494
071.2F/14-	82 $\frac{5}{8}$	41 $\frac{3}{8}$	38	53 $\frac{1}{2}$	34	1/2	*	1/2	2	580
080.2D/14-	92 $\frac{1}{8}$	35 $\frac{7}{8}$	49 $\frac{1}{4}$	63	28 $\frac{1}{8}$	3/4	*	3/4	2	694
080.2E/14-	92 $\frac{1}{8}$	35 $\frac{7}{8}$	49 $\frac{1}{4}$	63	28 $\frac{1}{8}$	3/4	*	3/4	2	745
080.2F/14-	92 $\frac{1}{8}$	41 $\frac{3}{4}$	49 $\frac{5}{8}$	63	34	3/4	*	3/4	2	838
090.2E/14-	98 $\frac{7}{8}$	44 $\frac{1}{8}$	61 $\frac{1}{8}$	70 $\frac{7}{8}$	35	1/2	*	1/2	2	1,124
090.2F/14-	98 $\frac{7}{8}$	44 $\frac{1}{8}$	61 $\frac{1}{8}$	70 $\frac{7}{8}$	35	1/2	*	1/2	2	1,197
050.2E/16-	57 $\frac{7}{8}$	25 $\frac{3}{8}$	29 $\frac{1}{2}$	39 $\frac{3}{8}$	21 $\frac{1}{2}$	1/2	*	1/2	1 $\frac{1}{4}$	209
050.2F/16-	57 $\frac{7}{8}$	32 $\frac{1}{2}$	29 $\frac{7}{8}$	39 $\frac{3}{8}$	27 $\frac{1}{2}$	1/2	*	1/2	1 $\frac{1}{4}$	231
050.2H/16-	57 $\frac{7}{8}$	32 $\frac{1}{2}$	29 $\frac{7}{8}$	39 $\frac{3}{8}$	27 $\frac{1}{2}$	1/2	*	1/2	1 $\frac{1}{4}$	291
071.2E/16-	82 $\frac{5}{8}$	35 $\frac{3}{8}$	37 $\frac{3}{8}$	53 $\frac{1}{2}$	28 $\frac{1}{8}$	1/2	*	1/2	2	472
071.2F/16-	82 $\frac{5}{8}$	41 $\frac{3}{8}$	38	53 $\frac{1}{2}$	34	1/2	*	1/2	2	527
071.2H/16-	82 $\frac{5}{8}$	41 $\frac{3}{8}$	38	53 $\frac{1}{2}$	34	1/2	*	1/2	2	624
080.2E/16-	92 $\frac{1}{8}$	35 $\frac{7}{8}$	49 $\frac{1}{4}$	63	28 $\frac{1}{8}$	3/4	*	3/4	2	688
080.2F/16-	92 $\frac{1}{8}$	41 $\frac{3}{4}$	49 $\frac{5}{8}$	63	34	3/4	*	3/4	2	983
080.2H/16-	92 $\frac{1}{8}$	41 $\frac{3}{4}$	49 $\frac{5}{8}$	63	34	3/4	*	3/4	2	917
090.2F/16-	98 $\frac{7}{8}$	44 $\frac{1}{8}$	61 $\frac{1}{8}$	70 $\frac{7}{8}$	35	1/2	*	1/2	2	1,102
090.2H/16-	98 $\frac{7}{8}$	48	61 $\frac{1}{8}$	70 $\frac{7}{8}$	39	1/2	*	1/2	2	1,369
050.2D/18-	57 $\frac{7}{8}$	25 $\frac{3}{8}$	29 $\frac{1}{2}$	39 $\frac{3}{8}$	21 $\frac{1}{2}$	1/2	*	1/2	1 $\frac{1}{4}$	190
050.2E/18-	57 $\frac{7}{8}$	25 $\frac{3}{8}$	29 $\frac{1}{2}$	39 $\frac{3}{8}$	21 $\frac{1}{2}$	1/2	*	1/2	1 $\frac{1}{4}$	209
050.2F/18-	57 $\frac{7}{8}$	32 $\frac{1}{2}$	29 $\frac{7}{8}$	39 $\frac{3}{8}$	27 $\frac{1}{2}$	1/2	*	1/2	1 $\frac{1}{4}$	231
050.2H/18-	57 $\frac{7}{8}$	32 $\frac{1}{2}$	29 $\frac{7}{8}$	39 $\frac{3}{8}$	27 $\frac{1}{2}$	1/2	*	1/2	1 $\frac{1}{4}$	269
071.2E/18-	82 $\frac{5}{8}$	35 $\frac{3}{8}$	37 $\frac{3}{8}$	53 $\frac{1}{2}$	28 $\frac{1}{8}$	1/2	*	1/2	2	472
071.2F/18-	82 $\frac{5}{8}$	41 $\frac{3}{8}$	38	53 $\frac{1}{2}$	34	1/2	*	1/2	2	531
071.2H/18-	82 $\frac{5}{8}$	41 $\frac{3}{8}$	38	53 $\frac{1}{2}$	34	1/2	*	1/2	2	584
080.2E/18-	92 $\frac{1}{8}$	35 $\frac{7}{8}$	49 $\frac{1}{4}$	63	28 $\frac{1}{8}$	3/4	*	3/4	2	694
080.2F/18-	92 $\frac{1}{8}$	41 $\frac{3}{4}$	49 $\frac{5}{8}$	63	34	3/4	*	3/4	2	769
080.2H/18-	92 $\frac{1}{8}$	41 $\frac{3}{4}$	49 $\frac{5}{8}$	63	34	3/4	*	3/4	2	851
090.2F/18-	98 $\frac{7}{8}$	44 $\frac{1}{8}$	61 $\frac{1}{8}$	70 $\frac{7}{8}$	35	1/2	*	1/2	2	1,111
090.2H/18-	98 $\frac{7}{8}$	48	61 $\frac{1}{8}$	70 $\frac{7}{8}$	39	1/2	*	1/2	2	1,283
050.2D/110	57 $\frac{7}{8}$	25 $\frac{3}{8}$	29 $\frac{1}{2}$	39 $\frac{3}{8}$	21 $\frac{1}{2}$	1/2	*	1/2	1 $\frac{1}{4}$	183
050.2E/110	57 $\frac{7}{8}$	25 $\frac{3}{8}$	29 $\frac{1}{2}$	39 $\frac{3}{8}$	21 $\frac{1}{2}$	1/2	*	1/2	1 $\frac{1}{4}$	203
050.2F/110	57 $\frac{7}{8}$	32 $\frac{1}{2}$	29 $\frac{7}{8}$	39 $\frac{3}{8}$	27 $\frac{1}{2}$	1/2	*	1/2	1 $\frac{1}{4}$	227
050.2H/110	57 $\frac{7}{8}$	32 $\frac{1}{2}$	29 $\frac{7}{8}$	39 $\frac{3}{8}$	27 $\frac{1}{2}$	1/2	*	1/2	1 $\frac{1}{4}$	251
071.2E/110	82 $\frac{5}{8}$	35 $\frac{3}{8}$	37 $\frac{3}{8}$	53 $\frac{1}{2}$	28 $\frac{1}{8}$	1/2	*	1/2	2	441
071.2F/110	82 $\frac{5}{8}$	41 $\frac{3}{8}$	38	53 $\frac{1}{2}$	34	1/2	*	1/2	2	516
071.2H/110	82 $\frac{5}{8}$	41 $\frac{3}{8}$	38	53 $\frac{1}{2}$	34	1/2	*	1/2	2	567
080.2F/110	92 $\frac{1}{8}$	41 $\frac{3}{4}$	49 $\frac{5}{8}$	63	34	3/4	*	3/4	2	741
080.2H/110	92 $\frac{1}{8}$	41 $\frac{3}{4}$	49 $\frac{5}{8}$	63	34	3/4	*	3/4	2	818
090.2F/110	98 $\frac{7}{8}$	44 $\frac{1}{8}$	61 $\frac{1}{8}$	70 $\frac{7}{8}$	35	1/2	*	1/2	2	1,071
090.2H/110	98 $\frac{7}{8}$	48	61 $\frac{1}{8}$	70 $\frac{7}{8}$	39	1/2	*	1/2	2	1,228
050.2D/112	57 $\frac{7}{8}$	25 $\frac{3}{8}$	29 $\frac{1}{2}$	39 $\frac{3}{8}$	21 $\frac{1}{2}$	1/2	*	1/2	1 $\frac{1}{4}$	181
050.2E/112	57 $\frac{7}{8}$	25 $\frac{3}{8}$	29 $\frac{1}{2}$	39 $\frac{3}{8}$	21 $\frac{1}{2}$	1/2	*	1/2	1 $\frac{1}{4}$	198
050.2F/112	57 $\frac{7}{8}$	32 $\frac{1}{2}$	29 $\frac{7}{8}$	39 $\frac{3}{8}$	27 $\frac{1}{2}$	1/2	*	1/2	1 $\frac{1}{4}$	220
050.2H/112	57 $\frac{7}{8}$	32 $\frac{1}{2}$	29 $\frac{7}{8}$	39 $\frac{3}{8}$	27 $\frac{1}{2}$	1/2	*	1/2	1 $\frac{1}{4}$	243
071.2E/112	82 $\frac{5}{8}$	35 $\frac{3}{8}$	37 $\frac{3}{8}$	53 $\frac{1}{2}$	28 $\frac{1}{8}$	1/2	*	1/2	2	430
071.2F/112	82 $\frac{5}{8}$	41 $\frac{3}{8}$	38	53 $\frac{1}{2}$	34	1/2	*	1/2	2	503
071.2H/112	82 $\frac{5}{8}$	41 $\frac{3}{8}$	38	53 $\frac{1}{2}$	34	1/2	*	1/2	2	549
080.2F/112	92 $\frac{1}{8}$	41 $\frac{3}{4}$	49 $\frac{5}{8}$	63	34	3/4	*	3/4	2	721
080.2H/112	92 $\frac{1}{8}$	41 $\frac{3}{4}$	49 $\frac{5}{8}$	63	34	3/4	*	3/4	2	794
090.2F/112	98 $\frac{7}{8}$	44 $\frac{1}{8}$	61 $\frac{1}{8}$	70 $\frac{7}{8}$	35	1/2	*	1/2	2	1,045
090.2H/112	98 $\frac{7}{8}$	48	61 $\frac{1}{8}$	70 $\frac{7}{8}$	39	1/2	*	1/2	2	1,193
050.2F/1A-	57 $\frac{7}{8}$	32 $\frac{1}{2}$	29 $\frac{7}{8}$	39 $\frac{3}{8}$	27 $\frac{1}{2}$	1/2	*	1/2	1 $\frac{1}{4}$	227
050.2H/1A-	57 $\frac{7}{8}$	32 $\frac{1}{2}$	29 $\frac{7}{8}$	39 $\frac{3}{8}$	27 $\frac{1}{2}$	1/2	*	1/2	1 $\frac{1}{4}$	260
071.2F/1A-	82 $\frac{5}{8}$	41 $\frac{3}{8}$	38	53 $\frac{1}{2}$	34	1/2	*	1/2	2	516
071.2H/1A-	82 $\frac{5}{8}$	41 $\frac{3}{8}$	38	53 $\frac{1}{2}$	34	1/2	*	1/2	2	569
080.2F/1A-	92 $\frac{1}{8}$	41 $\frac{3}{4}$	49 $\frac{5}{8}$	63	34	3/4	*	3/4	2	745

Model No. AGHN	DIMENSIONS					CONNECTIONS				Dry Weight lb
	L inch	B inch	H inch	E inch	F inch	Refrigerant *		Hot Gas	Drain	
						IN inch	OUT inch	IN inch	K NPT	
080.2H/1A-	92 $\frac{1}{8}$	41 $\frac{3}{4}$	49 $\frac{5}{8}$	63	34	3/4	*	3/4	2	831
090.2F/1A-	98 $\frac{7}{8}$	44 $\frac{1}{8}$	61 $\frac{3}{8}$	70 $\frac{7}{8}$	35	1/2	*	1/2	2	1,078
090.2H/1A-	98 $\frac{7}{8}$	48	61 $\frac{3}{8}$	70 $\frac{7}{8}$	39	1/2	*	1/2	2	1,248
050.2F/1B-	57 $\frac{7}{8}$	32 $\frac{1}{2}$	29 $\frac{7}{8}$	39 $\frac{3}{8}$	27 $\frac{1}{2}$	1/2	*	1/2	1 $\frac{1}{4}$	220
050.2H/1B-	57 $\frac{7}{8}$	32 $\frac{1}{2}$	29 $\frac{7}{8}$	39 $\frac{3}{8}$	27 $\frac{1}{2}$	1/2	*	1/2	1 $\frac{1}{4}$	249
071.2F/1B-	82 $\frac{5}{8}$	41 $\frac{3}{8}$	38	53 $\frac{1}{2}$	34	1/2	*	1/2	2	503
071.2H/1B-	82 $\frac{5}{8}$	41 $\frac{3}{8}$	38	53 $\frac{1}{2}$	34	1/2	*	1/2	2	549
080.2F/1B-	92 $\frac{1}{8}$	41 $\frac{3}{4}$	49 $\frac{5}{8}$	63	34	3/4	*	3/4	2	723
080.2H/1B-	92 $\frac{1}{8}$	41 $\frac{3}{4}$	49 $\frac{5}{8}$	63	34	3/4	*	3/4	2	798
090.2F/1B-	98 $\frac{7}{8}$	44 $\frac{1}{8}$	61 $\frac{3}{8}$	70 $\frac{7}{8}$	35	1/2	*	1/2	2	1,047
090.2H/1B-	98 $\frac{7}{8}$	48	61 $\frac{3}{8}$	70 $\frac{7}{8}$	39	1/2	*	1/2	2	1,202

* Refrigerant connections, in and out, vary depending on operating conditions. Consult Coolware for correct connection size.

DRAWING: 1 FAN MODELS

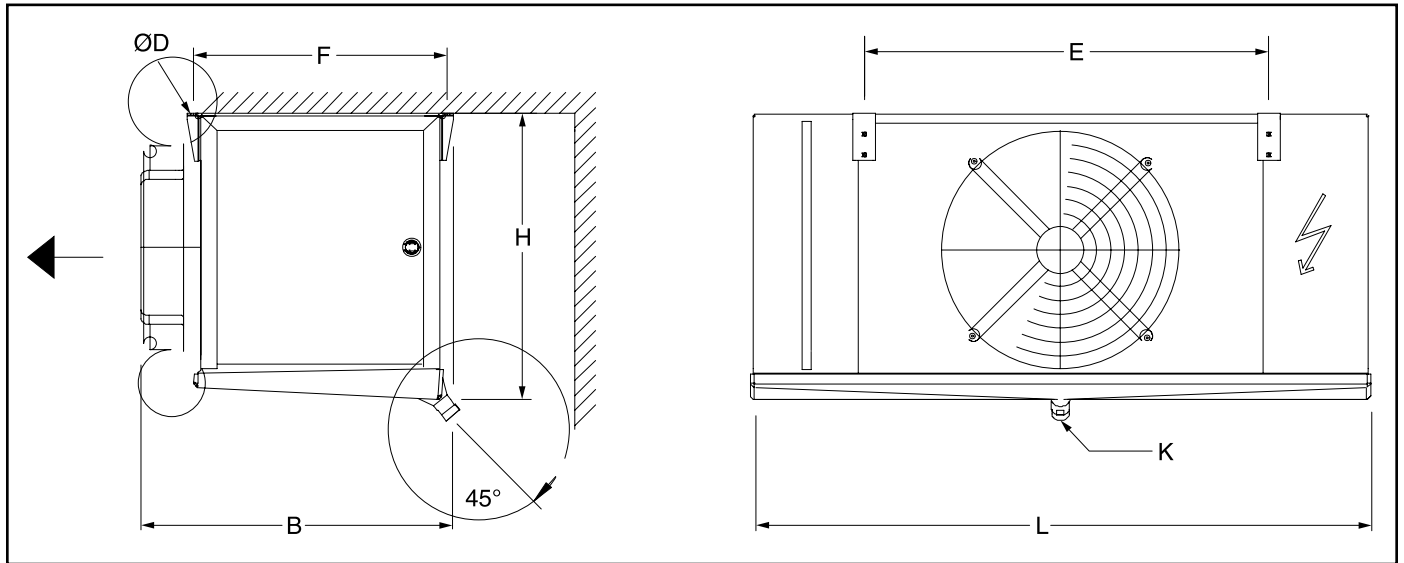

DIMENSIONS: 2 FAN MODELS

Model No AGHN	DIMENSIONS					CONNECTIONS				Dry Weight lb
	L inch	B inch	H inch	E inch	F inch	Refrigerant *		Hot Gas	Drain	
						IN inch	OUT inch	IN inch	K NPT	
050.2D/24-	97¼	25¾	29½	78¾	21¾	1/2	*	1/2	1¼	368
050.2E/24-	97¼	25¾	29½	78¾	21¾	1/2	*	1/2	1¼	408
050.2F/24-	97¼	32½	29⅞	78¾	26¾	3/4	*	3/4	1¼	485
071.2D/24-	136¼	35¾	37%	107⅞	26%	3/4	*	3/4	2	800
071.2E/24-	136¼	35¾	37%	107⅞	26%	3/4	*	3/4	2	873
071.2F/24-	136¼	41¾	38	107⅞	26¾	3/4	*	3/4	2	992
080.2D/24-	155⅞	35¾	49¼	126	26%	3/4	*	3/4	2	1,224
080.2E/24-	155½	35¾	49¼	126	26%	3/4	*	3/4	2	1,332
080.2F/24-	155½	41¾	49%	126	33%	1	*	1	2	1,497
090.2E/24-	169¾	44¼	61%	70%	26%	3/4	*	3/4	2	2,024
090.2F/24-	169¾	44¼	61%	70%	33%	1	*	1	2	2,172
050.2E/26-	97¼	25¾	29½	78¾	21¾	1/2	*	1/2	1¼	368
050.2F/26-	97¼	32½	29⅞	78¾	26%	3/4	*	3/4	1¼	434
050.2H/26-	97¼	32½	29⅞	78¾	26%	3/4	*	3/4	1¼	542
071.2E/26-	136¼	35¾	37%	107⅞	26%	3/4	*	3/4	2	802
071.2F/26-	136¼	41¾	38	107⅞	26%	3/4	*	3/4	2	895
071.2H/26-	136¼	41¾	38	107⅞	26%	3/4	*	3/4	2	1,089
080.2E/26-	155½	35¾	49¼	126	26%	3/4	*	3/4	2	1,210
080.2F/26-	155½	41¾	49%	126	33%	1	*	1	2	1,340
080.2H/26-	155½	41¾	49%	126	33%	1	*	1	2	1,647
090.2F/26-	169¾	44¼	61%	70%	33%	1	*	1	2	1,980
090.2H/26-	169¾	48	61%	70%	33%	1	*	1	2	2,432
050.2D/28-	97¼	25¾	29½	78¾	21¾	1/2	*	1/2	1¼	337
050.2E/28-	97¼	25¾	29½	78¾	21¾	1/2	*	1/2	1¼	368
050.2F/28-	97¼	32½	29⅞	78¾	26%	3/4	*	3/4	1¼	434
050.2H/28-	97¼	32½	29⅞	78¾	26%	3/4	*	3/4	1¼	498
071.2E/28-	136¼	35¾	37%	107⅞	26%	3/4	*	3/4	2	802
071.2F/28-	136¼	41¾	38	107⅞	26%	3/4	*	3/4	2	902
071.2H/28-	136¼	41¾	38	107⅞	26%	3/4	*	3/4	2	1,008
080.2E/28-	155½	35¾	49¼	126	26%	3/4	*	3/4	2	1,221
080.2F/28-	155½	41¾	49%	126	33%	1	*	1	2	1,354
080.2H/28-	155½	41¾	49%	126	33%	1	*	1	2	1,521
090.2F/28-	169¾	44¼	61%	70%	33%	1	*	1	2	2,000
090.2H/28-	169¾	48	61%	70%	33%	1	*	1	2	2,253
050.2D/210	97¼	25¾	29½	78¾	21¾	1/2	*	1/2	1¼	322
050.2E/210	97¼	25¾	29½	78¾	21¾	1/2	*	1/2	1¼	355
050.2F/210	97¼	32½	29⅞	78¾	26%	3/4	*	3/4	1¼	417
050.2H/210	97¼	32½	29⅞	78¾	26%	3/4	*	3/4	1¼	474
071.2E/210	136¼	35¾	37%	107⅞	26%	3/4	*	3/4	2	767
071.2F/210	136¼	41¾	38	107⅞	26%	3/4	*	3/4	2	862
071.2H/210	136¼	41¾	38	107⅞	26%	3/4	*	3/4	2	963
080.2F/210	155½	41¾	49%	126	33%	1	*	1	2	1,299
080.2H/210	155½	41¾	49%	126	33%	1	*	1	2	1,457
090.2F/210	169¾	44¼	61%	70%	33%	1	*	1	2	1,918
090.2H/210	169¾	48	61%	70%	33%	1	*	1	2	2,147
050.2D/212	97¼	25¾	29½	78¾	21¾	1/2	*	1/2	1¼	313
050.2E/212	97¼	25¾	29½	78¾	21¾	1/2	*	1/2	1¼	344
050.2F/212	97¼	32½	29⅞	78¾	26%	3/4	*	3/4	1¼	403
050.2H/212	97¼	32½	29⅞	78¾	26%	3/4	*	3/4	1¼	452
071.2E/212	136¼	35¾	37%	107⅞	26%	3/4	*	3/4	2	745
071.2F/212	136¼	41¾	38	107⅞	26%	3/4	*	3/4	2	838
071.2H/212	136¼	41¾	38	107⅞	26%	3/4	*	3/4	2	928
080.2F/212	155½	41¾	49%	126	33%	1	*	1	2	1,259
080.2H/212	155½	41¾	49%	126	33%	1	*	1	2	1,402
090.2F/212	169¾	44¼	61%	70%	33%	1	*	1	2	1,865
090.2H/212	169¾	48	61%	70%	33%	1	*	1	2	2,075
050.2F/2A-	97¼	32½	29⅞	78¾	26%	3/4	*	3/4	1¼	421
050.2H/2A-	97¼	32½	29⅞	78¾	26%	3/4	*	3/4	1¼	483
071.2F/2A-	136¼	41¾	38	107⅞	26%	3/4	*	3/4	2	873
071.2H/2A-	136¼	41¾	38	107⅞	26%	3/4	*	3/4	2	979
080.2F/2A-	155½	41¾	49%	126	33%	1	*	1	2	1,305

Model No AGHN	DIMENSIONS					CONNECTIONS				Dry Weight lb
	L inch	B inch	H inch	E inch	F inch	Refrigerant *		Hot Gas	Drain	
						IN inch	OUT inch	IN inch	K NPT	
080.2H/2A-	155½	41¾	49⅝	126	33⅜	1	*	1	2	1,473
090.2F/2A-	169⅝	44⅞	61⅜	70⅞	33⅜	1	*	1	2	1,931
090.2H/2A-	169⅝	48	61⅜	70⅞	33⅜	1	*	1	2	2,187
050.2F/2B-	97¼	32½	29⅞	78¾	26⅞	¾	*	¾	1¼	403
050.2H/2B-	97¼	32½	29⅞	78¾	26⅞	¾	*	¾	1¼	461
071.2F/2B-	136¼	41⅜	38	107⅞	26⅞	¾	*	¾	2	847
071.2H/2B-	136¼	41⅜	38	107⅞	26⅞	¾	*	¾	2	937
080.2F/2B-	155½	41¾	49⅝	126	33⅜	1	*	1	2	1,261
080.2H/2B-	155½	41¾	49⅝	126	33⅜	1	*	1	2	1,411
090.2F/2B-	169⅝	44⅞	61⅜	70⅞	33⅜	1	*	1	2	1,865
090.2H/2B-	169⅝	48	61⅜	70⅞	33⅜	1	*	1	2	2,092

* Refrigerant connections, in and out, vary depending on operating conditions. Consult Coolware for correct connection size.

DRAWING: 2 FAN MODELS

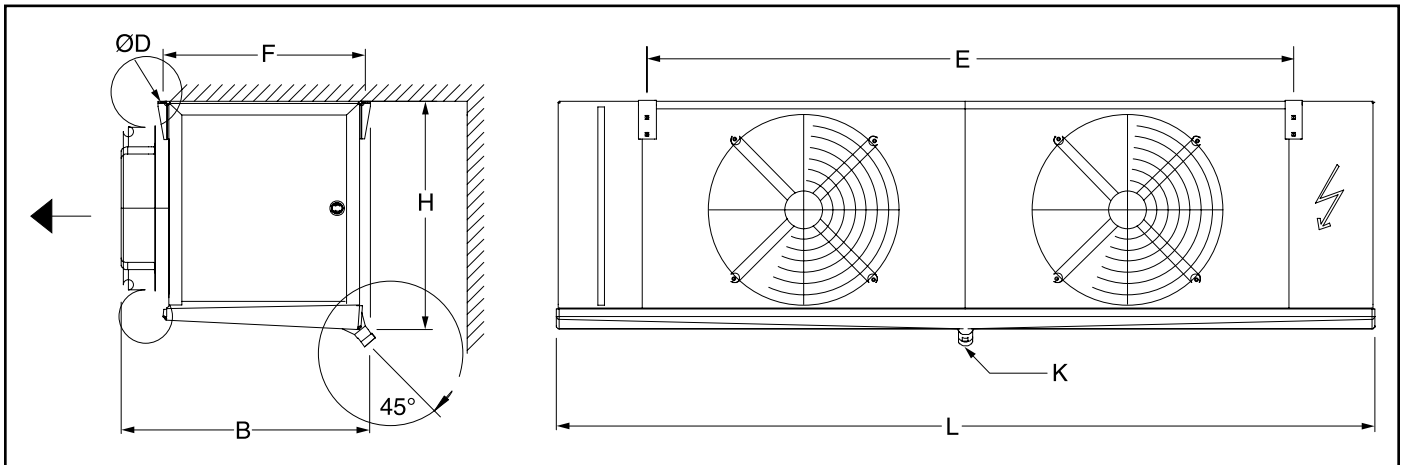

DIMENSIONS: 3 FAN MODELS

Model No AGHN	DIMENSIONS					CONNECTIONS				Dry Weight lb
	L inch	B inch	H inch	E inch	F inch	Refrigerant *		Hot Gas	Drain	
						IN inch	OUT inch	IN inch	K NPT	
050.2D/34-	140½	25¾	29½	39¾	21½	¾	*	¾	¼	536
050.2E/34-	140½	25¾	29½	39¾	21½	¾	*	¾	¼	595
050.2F/34-	140½	32½	29⅞	39⅞	27½	¾	*	¾	¼	690
071.2D/34-	189¾	35¾	37%	53½	28⅞	¾	*	¾	2	1,142
071.2E/34-	189¾	35¾	37%	53½	28⅞	¾	*	¾	2	1,246
071.2F/34-	189¾	41⅞	38	53½	34	¾	*	¾	2	1,409
080.2D/34-	218½	35¾	49¼	63	28⅞	1	*	1	2	1,759
080.2E/34-	218½	35¾	49¼	63	28⅞	1	*	1	2	1,925
080.2F/34-	218½	41¾	49⅞	63	34	1¼	*	1¼	2	2,163
090.2E/34-	240½	44⅞	61¾	70⅞	35	1	*	1	2	2,888
090.2F/34-	240½	44⅞	61¾	70⅞	35	1¼	*	1¼	2	3,108
050.2E/36-	140½	25¾	29½	39¾	21½	¾	*	¾	¼	534
050.2F/36-	140½	32½	29⅞	39¾	27½	¾	*	¾	¼	622
050.2H/36-	140½	32½	29⅞	39¾	27½	¾	*	¾	¼	778
071.2E/36-	189¾	35¾	37%	53½	28⅞	¾	*	¾	2	1,153
071.2F/36-	189¾	41⅞	38	53½	34	¾	*	¾	2	1,281
071.2H/36-	189¾	41⅞	38	53½	34	¾	*	¾	2	1,574
080.2E/36-	218½	35¾	49¼	63	28⅞	1	*	1	2	1,746
080.2F/36-	218½	41¾	49⅞	63	34	1¼	*	1¼	2	1,936
080.2H/36-	218½	41¾	49⅞	63	34	1¼	*	1¼	2	2,394
090.2F/36-	240½	44⅞	61¾	70⅞	35	1¼	*	1¼	2	2,822
090.2H/36-	240½	48	61¾	70⅞	39	1¼	*	1¼	2	3,496
050.2D/38-	140½	25¾	29½	39¾	21½	¾	*	¾	¼	487
050.2E/38-	140½	25¾	29½	39¾	21½	¾	*	¾	¼	542
050.2F/38-	140½	32½	29⅞	39¾	27½	¾	*	¾	¼	622
050.2H/38-	140½	32½	29⅞	39¾	27½	¾	*	¾	¼	710
071.2E/38-	189¾	35¾	37%	53½	28⅞	¾	*	¾	2	1,164
071.2F/38-	189¾	41⅞	38	53½	34	¾	*	¾	2	1,294
071.2H/38-	189¾	41⅞	38	53½	34	¾	*	¾	2	1,451
080.2E/38-	218½	35¾	49¼	63	28⅞	1	*	1	2	1,761
080.2F/38-	218½	41¾	49⅞	63	34	1¼	*	1¼	2	1,953
080.2H/38-	218½	41¾	49⅞	63	34	1¼	*	1¼	2	2,205
090.2F/38-	240½	44⅞	61¾	70⅞	35	1¼	*	1¼	2	2,848
090.2H/38-	240½	48	61¾	70⅞	39	1¼	*	1¼	2	3,230
050.2D/310	140½	25¾	29½	39¾	21½	¾	*	¾	¼	467
050.2E/310	140½	25¾	29½	39¾	21½	¾	*	¾	¼	516
050.2F/310	140½	32½	29⅞	39¾	27½	¾	*	¾	¼	589
050.2H/310	140½	32½	29⅞	39¾	27½	¾	*	¾	¼	672
071.2E/310	189¾	35¾	37%	53½	28⅞	¾	*	¾	2	1,089
071.2F/310	189¾	41⅞	38	53½	34	¾	*	¾	2	1,221
071.2H/310	189¾	41⅞	38	53½	34	¾	*	¾	2	1,371
080.2F/310	218½	41¾	49⅞	63	34	1¼	*	1¼	2	1,867
080.2H/310	218½	41¾	49⅞	63	34	1¼	*	1¼	2	2,110
090.2F/310	240½	44⅞	61¾	70⅞	35	1¼	*	1¼	2	2,727
090.2H/310	240½	48	61¾	70⅞	39	1¼	*	1¼	2	3,069
050.2D/312	140½	25¾	29½	39¾	21½	¾	*	¾	¼	454
050.2E/312	140½	25¾	29½	39¾	21½	¾	*	¾	¼	500
050.2F/312	140½	32½	29⅞	39¾	27½	¾	*	¾	¼	569
050.2H/312	140½	32½	29⅞	39¾	27½	¾	*	¾	¼	642
071.2E/312	189¾	35¾	37%	53½	28⅞	¾	*	¾	2	1,056
071.2F/312	189¾	41⅞	38	53½	34	¾	*	¾	2	1,182
071.2H/312	189¾	41⅞	38	53½	34	¾	*	¾	2	1,318
080.2F/312	218½	41¾	49⅞	63	34	1¼	*	1¼	2	1,797
080.2H/312	218½	41¾	49⅞	63	34	1¼	*	1¼	2	2,022
090.2F/312	240½	44⅞	61¾	70⅞	35	1¼	*	1¼	2	2,648
090.2H/312	240½	48	61¾	70⅞	39	1¼	*	1¼	2	2,963
050.2F/3A-	140½	32½	29⅞	39¾	27½	¾	*	¾	¼	593
050.2H/3A-	140½	32½	29⅞	39¾	27½	¾	*	¾	¼	683
071.2F/3A-	189¾	41⅞	38	53½	34	¾	*	¾	2	1,252
071.2H/3A-	189¾	41⅞	38	53½	34	¾	*	¾	2	1,407
080.2F/3A-	218½	41¾	49⅞	63	34	1¼	*	1¼	2	1,883

Model No AGHN	DIMENSIONS					CONNECTIONS				Dry Weight lb
	L inch	B inch	H inch	E inch	F inch	Refrigerant *		Hot Gas	Drain	
						IN inch	OUT inch	IN inch	K NPT	
080.2H/3A-	218½	41¾	49¾	63	34	1¼	*	1¼	2	2,134
090.2F/3A-	240½	44½	61¾	70¾	35	1¼	*	1¼	2	2,749
090.2H/3A-	240½	48	61¾	70¾	39	1¼	*	1¼	2	3,131
050.2F/3B-	140½	32½	29¾	39¾	27½	¾	*	¾	1¼	569
050.2H/3B-	140½	32½	29¾	39¾	27½	¾	*	¾	1¼	650
071.2F/3B-	189¾	41¾	38	53½	34	¾	*	¾	2	1,208
071.2H/3B-	189¾	41¾	38	53½	34	¾	*	¾	2	1,347
080.2F/3B-	218½	41¾	49¾	63	34	1¼	*	1¼	2	1,817
080.2H/3B-	218½	41¾	49¾	63	34	1¼	*	1¼	2	2,039
090.2F/3B-	240½	44½	61¾	70¾	35	1¼	*	1¼	2	2,648
090.2H/3B-	240½	48	61¾	70¾	39	1¼	*	1¼	2	2,989

* Refrigerant connections, in and out, vary depending on operating conditions. Consult Coolware for correct connection size.

DRAWING: 3 FAN MODELS

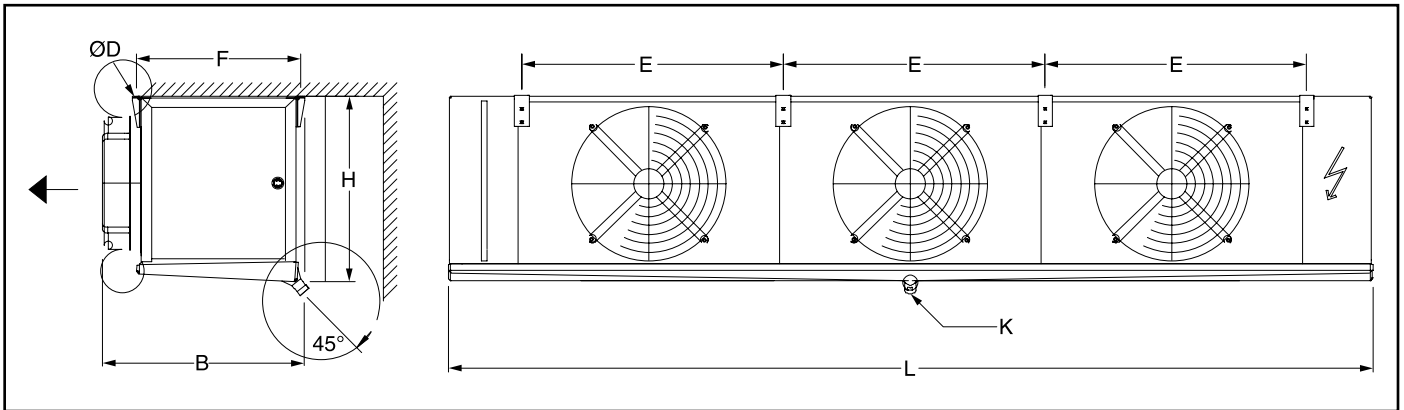

DIMENSIONS: 4 FAN MODELS

Model No AGHN	DIMENSIONS					CONNECTIONS				Dry Weight lb
	L inch	B inch	H inch	E inch	F inch	Refrigerant *		Hot Gas	Drain	
						IN inch	OUT inch	IN inch	K NPT	
050.2D/44-	179 ⁷ / ₈	25 ³ / ₈	29 ¹ / ₂	39 ³ / ₈	21 ¹ / ₂	3/4	*	3/4	1 ¹ / ₄	697
050.2E/44-	179 ⁷ / ₈	25 ³ / ₈	29 ¹ / ₂	39 ³ / ₈	21 ¹ / ₂	3/4	*	3/4	1 ¹ / ₄	776
050.2F/44-	179 ⁷ / ₈	32 ¹ / ₂	29 ⁷ / ₈	39 ³ / ₈	27 ¹ / ₂	3/4	*	3/4	1 ¹ / ₄	917
071.2D/44-	243 ¹ / ₄	35 ³ / ₈	37 ³ / ₈	53 ¹ / ₂	28 ¹ / ₈	3/4	*	3/4	2	1,519
071.2E/44-	243 ¹ / ₄	35 ³ / ₈	37 ³ / ₈	53 ¹ / ₂	28 ¹ / ₈	3/4	*	3/4	2	1,649
071.2F/44-	243 ¹ / ₄	41 ³ / ₈	38	53 ¹ / ₂	34	1	*	1	2	1,847
080.2D/44-	281 ¹ / ₈	35 ⁷ / ₈	49 ¹ / ₄	63	28 ¹ / ₈	1	*	1	2	2,315
080.2E/44-	281 ¹ / ₈	35 ⁷ / ₈	49 ¹ / ₄	63	28 ¹ / ₈	1	*	1	2	2,515
080.2F/44-	281 ¹ / ₈	41 ³ / ₄	49 ⁵ / ₈	63	34	1 ¹ / ₄	*	1 ¹ / ₄	2	2,981
090.2E/44-	311 ³ / ₈	44 ¹ / ₈	61 ¹ / ₈	70 ⁷ / ₈	35	1 ¹ / ₄	*	1 ¹ / ₄	2	3,759
090.2F/44-	311 ³ / ₈	44 ¹ / ₈	61 ¹ / ₈	70 ⁷ / ₈	35	1 ¹ / ₄	*	1 ¹ / ₄	2	4,083
050.2E/46-	179 ⁷ / ₈	25 ³ / ₈	29 ¹ / ₂	39 ³ / ₈	21 ¹ / ₂	3/4	*	3/4	1 ¹ / ₄	701
050.2F/46-	179 ⁷ / ₈	32 ¹ / ₂	29 ⁷ / ₈	39 ³ / ₈	27 ¹ / ₂	3/4	*	3/4	1 ¹ / ₄	811
050.2H/46-	179 ⁷ / ₈	32 ¹ / ₂	29 ⁷ / ₈	39 ³ / ₈	27 ¹ / ₂	3/4	*	3/4	1 ¹ / ₄	1,032
071.2E/46-	243 ¹ / ₄	35 ³ / ₈	37 ³ / ₈	53 ¹ / ₂	28 ¹ / ₈	3/4	*	3/4	2	1,508
071.2F/46-	243 ¹ / ₄	41 ³ / ₈	38	53 ¹ / ₂	34	1	*	1	2	1,673
071.2H/46-	243 ¹ / ₄	41 ³ / ₈	38	53 ¹ / ₂	34	1	*	1	2	2,064
080.2E/46-	281 ¹ / ₈	35 ⁷ / ₈	49 ¹ / ₄	63	28 ¹ / ₈	1	*	1	2	2,288
080.2F/46-	281 ¹ / ₈	41 ³ / ₄	49 ⁵ / ₈	63	34	1 ¹ / ₄	*	1 ¹ / ₄	2	2,537
080.2H/46-	281 ¹ / ₈	41 ³ / ₄	49 ⁵ / ₈	63	34	1 ¹ / ₄	*	1 ¹ / ₄	2	3,150
090.2F/46-	311 ³ / ₈	44 ¹ / ₈	61 ¹ / ₈	70 ⁷ / ₈	35	1 ¹ / ₄	*	1 ¹ / ₄	2	3,702
090.2H/46-	311 ³ / ₈	48	61 ¹ / ₈	70 ⁷ / ₈	39	1 ¹ / ₄	*	1 ¹ / ₄	2	4,590
050.2D/48-	179 ⁷ / ₈	25 ³ / ₈	29 ¹ / ₂	39 ³ / ₈	21 ¹ / ₂	3/4	*	3/4	1 ¹ / ₄	635
050.2E/48-	179 ⁷ / ₈	25 ³ / ₈	29 ¹ / ₂	39 ³ / ₈	21 ¹ / ₂	3/4	*	3/4	1 ¹ / ₄	705
050.2F/48-	179 ⁷ / ₈	32 ¹ / ₂	29 ⁷ / ₈	39 ³ / ₈	27 ¹ / ₂	3/4	*	3/4	1 ¹ / ₄	820
050.2H/48-	179 ⁷ / ₈	32 ¹ / ₂	29 ⁷ / ₈	39 ³ / ₈	27 ¹ / ₂	3/4	*	3/4	1 ¹ / ₄	941
071.2E/48-	243 ¹ / ₄	35 ³ / ₈	37 ³ / ₈	53 ¹ / ₂	28 ¹ / ₈	3/4	*	3/4	2	1,521
071.2F/48-	243 ¹ / ₄	41 ³ / ₈	38	53 ¹ / ₂	34	1	*	1	2	1,689
071.2H/48-	243 ¹ / ₄	41 ³ / ₈	38	53 ¹ / ₂	34	1	*	1	2	1,903
080.2E/48-	281 ¹ / ₈	35 ⁷ / ₈	49 ¹ / ₄	63	28 ¹ / ₈	1	*	1	2	2,308
080.2F/48-	281 ¹ / ₈	41 ³ / ₄	49 ⁵ / ₈	63	34	1 ¹ / ₄	*	1 ¹ / ₄	2	2,564
080.2H/48-	281 ¹ / ₈	41 ³ / ₄	49 ⁵ / ₈	63	34	1 ¹ / ₄	*	1 ¹ / ₄	2	2,897
090.2F/48-	311 ³ / ₈	44 ¹ / ₈	61 ¹ / ₈	70 ⁷ / ₈	35	1 ¹ / ₄	*	1 ¹ / ₄	2	3,737
090.2H/48-	311 ³ / ₈	48	61 ¹ / ₈	70 ⁷ / ₈	39	1 ¹ / ₄	*	1 ¹ / ₄	2	4,233
050.2D/410	179 ⁷ / ₈	25 ³ / ₈	29 ¹ / ₂	39 ³ / ₈	21 ¹ / ₂	3/4	*	3/4	1 ¹ / ₄	608
050.2E/410	179 ⁷ / ₈	25 ³ / ₈	29 ¹ / ₂	39 ³ / ₈	21 ¹ / ₂	3/4	*	3/4	1 ¹ / ₄	675
050.2F/410	179 ⁷ / ₈	32 ¹ / ₂	29 ⁷ / ₈	39 ³ / ₈	27 ¹ / ₂	3/4	*	3/4	1 ¹ / ₄	778
050.2H/410	179 ⁷ / ₈	32 ¹ / ₂	29 ⁷ / ₈	39 ³ / ₈	27 ¹ / ₂	3/4	*	3/4	1 ¹ / ₄	888
071.2E/410	243 ¹ / ₄	35 ³ / ₈	37 ³ / ₈	53 ¹ / ₂	28 ¹ / ₈	3/4	*	3/4	2	1,459
071.2F/410	243 ¹ / ₄	41 ³ / ₈	38	53 ¹ / ₂	34	1	*	1	2	1,625
071.2H/410	243 ¹ / ₄	41 ³ / ₈	38	53 ¹ / ₂	34	1	*	1	2	1,817
080.2F/410	281 ¹ / ₈	41 ³ / ₄	49 ⁵ / ₈	63	34	1 ¹ / ₄	*	1 ¹ / ₄	2	2,452
080.2H/410	281 ¹ / ₈	41 ³ / ₄	49 ⁵ / ₈	63	34	1 ¹ / ₄	*	1 ¹ / ₄	2	2,760
090.2F/410	311 ³ / ₈	44 ¹ / ₈	61 ¹ / ₈	70 ⁷ / ₈	35	1 ¹ / ₄	*	1 ¹ / ₄	2	3,576
090.2H/410	311 ³ / ₈	48	61 ¹ / ₈	70 ⁷ / ₈	39	1 ¹ / ₄	*	1 ¹ / ₄	2	4,019
050.2D/412	179 ⁷ / ₈	25 ³ / ₈	29 ¹ / ₂	39 ³ / ₈	21 ¹ / ₂	3/4	*	3/4	1 ¹ / ₄	589
050.2E/412	179 ⁷ / ₈	25 ³ / ₈	29 ¹ / ₂	39 ³ / ₈	21 ¹ / ₂	3/4	*	3/4	1 ¹ / ₄	650
050.2F/412	179 ⁷ / ₈	32 ¹ / ₂	29 ⁷ / ₈	39 ³ / ₈	27 ¹ / ₂	3/4	*	3/4	1 ¹ / ₄	752
050.2H/412	179 ⁷ / ₈	32 ¹ / ₂	29 ⁷ / ₈	39 ³ / ₈	27 ¹ / ₂	3/4	*	3/4	1 ¹ / ₄	849
071.2E/412	243 ¹ / ₄	35 ³ / ₈	37 ³ / ₈	53 ¹ / ₂	28 ¹ / ₈	3/4	*	3/4	2	1,420
071.2F/412	243 ¹ / ₄	41 ³ / ₈	38	53 ¹ / ₂	34	1	*	1	2	1,596
071.2H/412	243 ¹ / ₄	41 ³ / ₈	38	53 ¹ / ₂	34	1	*	1	2	1,777
080.2F/412	281 ¹ / ₈	41 ³ / ₄	49 ⁵ / ₈	63	34	1 ¹ / ₄	*	1 ¹ / ₄	2	2,418
080.2H/412	281 ¹ / ₈	41 ³ / ₄	49 ⁵ / ₈	63	34	1 ¹ / ₄	*	1 ¹ / ₄	2	2,701
090.2F/412	311 ³ / ₈	44 ¹ / ₈	61 ¹ / ₈	70 ⁷ / ₈	35	1 ¹ / ₄	*	1 ¹ / ₄	2	3,468
090.2H/412	311 ³ / ₈	48	61 ¹ / ₈	70 ⁷ / ₈	39	1 ¹ / ₄	*	1 ¹ / ₄	2	3,878
050.2F/4A-	179 ⁷ / ₈	32 ¹ / ₂	29 ⁷ / ₈	39 ³ / ₈	27 ¹ / ₂	3/4	*	3/4	1 ¹ / ₄	787
050.2H/4A-	179 ⁷ / ₈	32 ¹ / ₂	29 ⁷ / ₈	39 ³ / ₈	27 ¹ / ₂	3/4	*	3/4	1 ¹ / ₄	860
071.2F/4A-	243 ¹ / ₄	41 ³ / ₈	38	53 ¹ / ₂	34	1	*	1	2	1,634
071.2H/4A-	243 ¹ / ₄	41 ³ / ₈	38	53 ¹ / ₂	34	1	*	1	2	1,841
080.2F/4A-	281 ¹ / ₈	41 ³ / ₄	49 ⁵ / ₈	63	34	1 ¹ / ₄	*	1 ¹ / ₄	2	2,467

Model No AGHN	DIMENSIONS					CONNECTIONS				Dry Weight lb
	L inch	B inch	H inch	E inch	F inch	Refrigerant *		Hot Gas	Drain	
						IN inch	OUT inch	IN inch	K NPT	
080.2H/4A-	281 $\frac{1}{8}$	41 $\frac{3}{4}$	49 $\frac{5}{8}$	63	34	1 $\frac{1}{4}$	*	1 $\frac{1}{4}$	2	2,802
090.2F/4A-	311 $\frac{3}{8}$	44 $\frac{1}{8}$	61 $\frac{3}{8}$	70 $\frac{7}{8}$	35	1 $\frac{1}{4}$	*	1 $\frac{1}{4}$	2	3,602
090.2H/4A-	311 $\frac{3}{8}$	48	61 $\frac{3}{8}$	70 $\frac{7}{8}$	39	1 $\frac{1}{4}$	*	1 $\frac{1}{4}$	2	4,101
050.2F/4B-	179 $\frac{7}{8}$	32 $\frac{1}{2}$	29 $\frac{7}{8}$	39 $\frac{3}{8}$	27 $\frac{1}{2}$	3/4	*	3/4	1 $\frac{1}{4}$	752
050.2H/4B-	179 $\frac{7}{8}$	32 $\frac{1}{2}$	29 $\frac{7}{8}$	39 $\frac{3}{8}$	27 $\frac{1}{2}$	3/4	*	3/4	1 $\frac{1}{4}$	860
071.2F/4B-	243 $\frac{1}{4}$	41 $\frac{3}{8}$	38	53 $\frac{1}{2}$	34	1	*	1	2	1,578
071.2H/4B-	243 $\frac{1}{4}$	41 $\frac{3}{8}$	38	53 $\frac{1}{2}$	34	1	*	1	2	1,761
080.2F/4B-	281 $\frac{1}{8}$	41 $\frac{3}{4}$	49 $\frac{5}{8}$	63	34	1 $\frac{1}{4}$	*	1 $\frac{1}{4}$	2	2,381
080.2H/4B-	281 $\frac{1}{8}$	41 $\frac{3}{4}$	49 $\frac{5}{8}$	63	34	1 $\frac{1}{4}$	*	1 $\frac{1}{4}$	2	2,676
090.2F/4B-	311 $\frac{3}{8}$	44 $\frac{1}{8}$	61 $\frac{3}{8}$	70 $\frac{7}{8}$	35	1 $\frac{1}{4}$	*	1 $\frac{1}{4}$	2	3,468
090.2H/4B-	311 $\frac{3}{8}$	48	61 $\frac{3}{8}$	70 $\frac{7}{8}$	39	1 $\frac{1}{4}$	*	1 $\frac{1}{4}$	2	3,913

* Refrigerant connections, in and out, vary depending on operating conditions. Consult Coolware for correct connection size.

DRAWING: 4 FAN MODELS

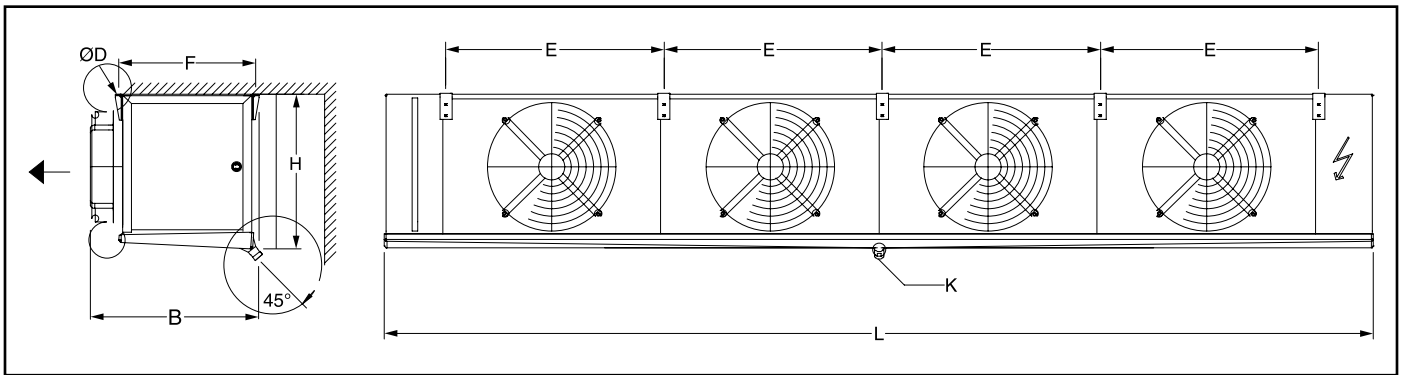

Form 610-10-SED2 (2010-02)
Supersedes: NOTHING
Subject to change without notice
Published in USA • GUI 1M

© 2009 Johnson Controls Inc. - ALL RIGHTS RESERVED



JOHNSON CONTROLS
100 CV Avenue • P.O. Box 997
Waynesboro, PA 17268-0997 USA
Phone: 717-762-2121 • FAX: 717-762-8624
www.johnsoncontrols.com