



# OMNI-Test Laboratories, Inc.

EPA Standard of Performance for New Residential Wood Heaters

## Certification Test Report

### Non-Confidential Business Information (Non-CBI)

**Manufacturer:** Hearth & Home Technologies, Inc.  
**Heater Type:** Wood-Fired, Non-Catalytic Fireplace  
**Model:** Pioneer III

**Prepared for:** Hearth & Home Technologies, Inc.  
1951 W Saunders St.  
Mt. Pleasant, IA 52641  
USA

**Prepared by:** OMNI-Test Laboratories, Inc.  
13327 NE Airport Way  
Portland, OR 97230  
(503) 643-3788

**Test Period:** January 29-31, 2019

**Report Date:** March 11, 2019

**Report Number:** 0061WF102E

***All data and information contained in this report are confidential and proprietary to Hearth & Home Technologies, Inc.. Its significance is subject to the adequacy and representative character of the samples and to the comprehensiveness of the tests, examinations, or surveys made. The contents of this report cannot be copied or quoted, except in full, without specific, written authorization from Hearth & Home Technologies, Inc. and OMNI-Test Laboratories, Inc. No use of the OMNI-Test Laboratories, Inc. name, logo, or registered mark (O-TL) is permitted, except as expressly authorized by OMNI-Test Laboratories, Inc. in writing.***

## AUTHORIZED SIGNATORIES

This report has been reviewed and approved by the following authorized signatories:

### Evaluator:

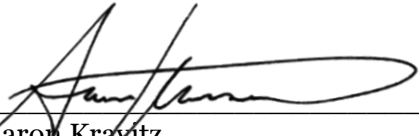

---

Aaron Krawitz  
Testing Supervisor

### QA Review:



---

Alex Tiegs  
President

## TABLE OF CONTENTS

PREFACE .....	(3 pages)
<b>Section 1 –Appliance, Testing, &amp; Results .....</b>	<b>4</b>
1.1 Summary Tables .....	5
Table 1 – ASTM E3053 Weighted Averages.....	5
Table 2 – Weighted Average Summary.....	5
Table 3 – First Hour Emissions .....	5
Table 4 – Test Run Results Summary.....	6
Table 5 – Test Conditions Summary.....	7
1.2 Procedures & Results Summary .....	8
1.3 Appliance Description .....	10
1.4 Photographs .....	11
<b>Section 2 – Test Data .....</b>	<b>16</b>
2.1 Manufacturer’s Specified Procedures .....	17
2.2 Test Data by Run.....	20
2.3 Sample Analysis & Tares.....	48
<b>Section 3 –Laboratory Quality Assurance .....</b>	<b>60</b>
3.1 Quality Assurance/Quality Control.....	61
3.2 Calibration Data.....	62
3.3 Example Calculations .....	80
<b>Appendix A – Labeling &amp; Owner’s Manual</b>	
<b>Appendix B - Alt-125 Letter</b>	

# **Section 1**

## **Appliance, Testing, & Results**

- 1.1 – Summary Tables
- 1.2 – Procedures and Results Summary
- 1.3 – Appliance Description
- 1.4 – Photographs

## 1.1 – Summary Tables

**Table 1 – ASTM E3053 Weighted Averages**

PM Emission Rate - g/h	2.0
CO Emissions Rate - g/min	2.56
Overall Efficiency - CSA B415.1-10	
% HHV Basis	69.1%
% LHV Basis	74.3%
Heat Output Range - Btu/h	14,657 to 72,724

**Table 2 – Weighted Average Summary**

Average for Each Test Run Category	L	M	H
Burn Rate - kg/h DB	1.07	1.16	6.30
PM Emission Rate - g/h	0.96	1.70	4.44
CO Emissions Rate - g/min	1.97	2.165	3.55
Overall Efficiency - CSA B415.1-10			
% HHV Basis	69.5%	68.5%	69.6%
% LHV Basis	74.7%	73.6%	74.7%
Heat Output - Btu/h	14657	15500	72724
Category Weighting	40%	40%	20%

**Table 3 – First Hour Emissions**

Test Run #	1 (High)	1 (Med)	2 (Low)
First Hour PM Emission Rate - g/h	8.58	16.68	13.49

## 1.1 – Summary Tables

**Table 4 – Test Run Results Summary**

Test Run #	1 (High)	1 (Med)	2 (Low)
Date Tested	1/29/19	1/29/19	1/31/19
Test Run Category	H	M	L
Burn Rate - kg/h DB	6.30	1.16	1.07
Burn Rate - As % of Low to High Midpoint	N/A	104%	na
Burn Duration - h	2.95	15.05	16.48
Heat Output - Btu/h	72724	15500	14657
Average Dilution Tunnel Flow Rate - dscfm	128.93	151.88	153.83
Average Sample Flow Rates - dscfm			
Train 1	0.143	0.142	0.139
Train 2	0.140	0.142	0.139
Total PM Emissions - g			
Train 1	12.79	25.77	17.30
Train 2	13.42	25.42	14.46
Average	13.11	25.60	15.88
PM Emission Train Precision - %	1.2%	0.3%	9.0%
PM Emission Train Precision - g/kg	0.02	0.01	0.16
PM Emission Rate - g/h	4.44	1.70	0.96
Total CO Emissions - g	624	1955	1949
CO Emissions Rate - g/min	1.97	3.165	3.55
Overall Efficiency - CSA B415.1-10			
% HHV Basis	69.6%	68.5%	69.5%
% LHV Basis	74.7%	73.6%	74.7%

## 1.1 – Summary Tables

**Table 5 – Test Conditions Summary**

Test Run #	1 (High)	1 (Med)	2 (Low)
Date Tested	1/29/2019	1/29/2019	1/31/2019
Test Run Category (L, M, H)	H	M	L
Average Barometric Pressure - in Hg	29.40	29.43	29.53
Max. Observed Ambient Temp - °F	78	78	82
Min. Observed Ambient Temp - °F	67	71	69
Max. Observed Filter Temp - °F	87	90	87
<b>Test Run Air Settings</b>			
Primary (measured up from minimum)	Auto - High	Auto - Med	Auto - Min
Secondary (measured up from minimum)	Auto	Auto	Auto
Convection Air Fan Setting	Auto	Auto	Auto
<b>Test Fuel Load</b>			
Cordwood Fuel Species	White Oak	White Oak	White Oak
Specific Gravity	0.71	0.71	0.71
Higher Heating Value - Btu/lb	8819	8819	8819
Nom. Test Fuel Load Piece Length - in.	24	24	24
Number of Test Fuel Pieces	5	6	6
<b>Test Fuel Weight</b>			
Kindling - As Fired lb	6.70	N/A	N/A
Kindling Wt. - As % of Test Fuel Load	17%	N/A	N/A
Kindling Moisture - % DB	7.3%	N/A	N/A
Kindling - kg DB	2.83	N/A	N/A
SU Fuel - As Fired lb	11.30	N/A	N/A
SU Fuel Wt. - As % of Test Fuel Load	30%	N/A	N/A
SU Fuel Moisture - % DB	24.2%	N/A	N/A
SU Fuel - kg DB	4.13	N/A	N/A
Test Fuel Load - As Fired lb	38.30	47.30	47.80
Ave. Test Fuel Load MC % DB	21.2%	22.6%	22.4%
Test Fuel Load - kg DB	14.34	17.49	17.71
Test Fuel Loading Density - lb/ft <sup>3</sup>	9.58	11.83	11.95
Residual SU Fuel Wt. - As Fired lb	7.50	N/A	N/A
Residual SU Fuel Wt. - As % of Test Fuel Load	20%	N/A	N/A
Test Run Duration - minutes	177	903	989
Test Run Duration - h	2.95	15.05	16.48
Test Fuel Load Wt. at End of Test - As Fired lb	3.5	0	0
Total Total Fuel Burned - kg DB	16.31	17.49	17.71
% Test Fuel Load Wt. at End of Test	9.1%	0.0%	0.0%

## **1.2 – Procedures and Results Summary**

### **TESTING PROCEDURE**

The Pioneer III was tested in accordance with the U.S. EPA 40 CFR Part 60, Subpart AAA – Standards of Performance for New Residential Wood Heaters using ASTM E2515, ASTM E3053, and EPA ALT-125. The fuel used for certification testing was white oak cordwood meeting the specifications of ASTM E3053. Particulate emissions were measured using dual sampling trains consisting of two sets of filters (front and back).

The unit was installed in accordance with the manufacturer's instructions. Two complete test runs were performed, each consisting of a high burn rate test started from cold and a low or medium burn rate test started from the high burn's coal bed. Emissions were sampled for only one of the high burn rate tests.

The Pioneer III's control system uses a programmable thermostat, so burn rates were achieved by setting the thermostat, per the manufacturer's instructions, to call for less heat to achieve a low burn. The high fire tests were conducted with a constant call for heat.

### **RESULTS SUMMARY**

Proportionality results of the integrated test run, in addition to all other validity criteria, were within specified limits, and no sampling anomalies occurred. All burn rate categories were achieved. Therefore, all test runs are considered valid.

The results of the integrated test run indicate a weighted average particulate emission rate of 2.0 g/hr. The Pioneer III results are within the emission limit of 2.5 g/hr for affected appliances manufactured or sold at retail on or after May 15, 2020.

The model Pioneer III was tested for thermal efficiency and carbon monoxide (CO) emissions in accordance with CSA B415.1-10. The heater has a demonstrated an average thermal efficiency of 69.1%. The calculated CO emission rate was 2.56 g/min.

Upon completion of emissions certification testing, the sample unit was sealed and will be stored by the manufacturer in accordance with the requirements of the CFR.



## 1.2 - Procedures and Results Summary

### RUN NARRATIVE

**Run 1 – High** – This run was performed as a cold start per ASTM E3053. Sampling was conducted in accordance with ASTM E2515 and EPA ALT-125. The thermostat was set to call for heat at all times. Ignition was achieved by the use of a propane torch for 60 seconds. Startup fuel was loaded at 9 minutes after the start of sampling, and the test fuel load was loaded at 26 minutes. All air adjustments were completed by 30 minutes. In addition to the 60-minute filter, three front filters were changed in order to maintain sample rates. The test was concluded with 3.5 lb of residual fuel in the firebox. All proportionality, sampling, and procedural requirements were met, so this is a valid run for inclusion in the weighted average.

**Run 1 – Medium** – This run was performed as a hot start per ASTM E3053, using the remainder of Run 1- High as a coal bed. Sampling was conducted in accordance with ASTM E2515 and EPA ALT-125. The thermostat was set to call for heat on after 13 hours of elapsed test time. The test fuel was loaded by 30 seconds of test time. All air adjustments were completed by 4 minutes. In addition to the 60-minute filter, five front filters were changed in order to maintain sample rates. The test was concluded with zero residual fuel in the firebox. All proportionality, sampling, and procedural requirements were met, so this is a valid run for inclusion in the weighted average.

**Run 2 – High** – This run was performed as a cold start per ASTM E3053. No sampling was conducted for this run. The thermostat was set to call for heat at all times. Ignition was achieved by the use of a propane torch for 60 seconds. Startup fuel was loaded at 10 minutes after the start of the test, and the test fuel load was loaded at 27 minutes. All air adjustments were completed by 28 minutes. The test was concluded with 3.5 lb of residual fuel in the firebox. All procedural requirements were met, so this is a valid run for use as a coal bed.

**Run 2 – Low** – This run was performed as a hot start per ASTM E3053, using the remainder of Run 2- High as a coal bed. Sampling was conducted in accordance with ASTM E2515 and EPA ALT-125. The thermostat was set to call for heat on after 16 hours of elapsed test time. The test fuel was loaded by 30 seconds of test time. All air adjustments were completed by 4:30. In addition to the 60-minute filter, two front filters were changed in order to maintain sample rates. The test was concluded with zero residual fuel in the firebox. All proportionality, sampling, and procedural requirements were met, so this is a valid run for inclusion in the weighted average.

### 1.3 - Appliance Description

**Manufacturer:** Hearth & Home Technologies, Inc.

**Fireplace Model:** Pioneer III

**Type:** Wood fired, noncatalytic, thermostatically controlled fireplace.

The Pioneer III is a factory-built fireplace featuring automatically controlled combustion air, a loading door with a large glass viewing window, room air blowers, and an insulated enclosure. Firebox volume was calculated at 4.06 cubic feet, see section C of this report for details.

Air enters through an intake, varied in area by a thermostatically controlled linear actuator. At minimum setting, the intake area is 0.149 in<sup>2</sup>, and at maximum it is 6.138in<sup>2</sup>

Air travels from the intake to a variety of primary and secondary combustion air ports within the firebox. Primary air enters through an air wash above the loading door and a pilot air port at the lower front of the firebox. Secondary air enters through three secondary tubes located at the top of the firebox under the baffle and through ports adjacent to the air wash directed over the top of the baffle. After travelling around the baffle, combustion products exit the firebox through an 8" flue collar located at the top of the unit.

Electrical functions are regulated by a digital control board supplied by a 115V cord connection or, in the event of a power failure, a battery backup. The intake can be temporarily set to maintain a fully open "boost" position with a user-actuated button. Users cannot adjust the "boost" setting duration. The only other user-controlled setting is the room air fans, which can be controlled by a knob on the front of the enclosure. However, the control system can override the user setting to keep the firebox temperature inside the manufacturer's specified optimum range.

The glass panel is constructed of 5mm ceramic glass and is 15" x 24" with a rounded top. The refractory bricks are oversized 13.25" x 4.5" x 1.5" and feature steel corner protection on each vertical brick. Firebox insulation panels are 1.5" thick fiberglass blanket.

More detailed information is shown in the manufacturer's design drawings, Appendix C of this report. This information is considered confidential business information (CBI) by the manufacturer and is not included in the non-CBI version of this report.



**Pioneer III – Sealed Test Unit**

## 1.4 - Photographs



**Pioneer III Front**



**Pioneer III Back**



**Pioneer III Left**



**Pioneer III Right**

## 1.4 - Photographs



Run 1 Kindling



Run 1 Startup Fuel



Run 1 (High) Core Load



Run 1 (High) Remainder Load



Run 1 (High) Kindling Loaded



Run 1 (High) Test Fuel Loaded

## 1.4 - Photographs



Run 1 (Med) Core Load



Run 1 (Med) Remainder Load



Run 1 (Med) Coal Bed



Run 1 (Med) Test Fuel Loaded

## 1.4 - Photographs



Run 2 Kindling



Run 2 Startup Fuel



Run 2 (High) Core Load



Run 2 (High) Remainder Load



Run 2 (High) Kindling Loaded



Run 2 (High) Test Fuel Loaded

## 1.4 - Photographs



Run 2 (Low) Core Load



Run 2 (Low) Remainder Load



Run 2 (Low) Coal Bed



Run 2 (Low) Test Fuel Loaded

## **Section 2**

### **Test Data**

2.1 Manufacturer's Specified Procedures

2.1 Test Data by Run

2.2 Sample Analysis & Tares



## **2.1 - Manufacturer's Specified Procedures**

## **PIONEER III LAB NOTES FOR LOADING FIREPLACE**

- **Leave the door open 2 inches for up to 3 minutes or when a good strong flame is present close the door latching it lightly then push the SBT button.**
- **After a good strong flame gets established approximately 6 minutes shut and latch the door then push the SBT button.**
- **When ½ to 2/3 of the kindling burns down and a good strong flame is present open the door, push the SBT button and level out the firebox.**
- **Add 11 to 12 pounds of start-up wood (1-3 inch diameter pieces of cord wood) by stacking them in a crisscross pattern. This will allow for proper air flow.**
- **Leave the door slightly open 2 inches for up to 3 minutes or until a good strong flame is present. Then close the door, latching it lightly and push the SBT button.**
- **In approximately 5 minutes or when the flame is good and strong shut and latch the door. Then push the SBT button.**
- **When the kindling has burned down approximately ½ to 2/3rds and a good strong flame is present press the SBT button and open the door.**
- **Level the coal bed insuring that the combustion air holes are not blocked.**

- **Load 5-6 pieces of cord wood 24 inches long to achieve maximum firebox volume, stack 2-3 pieces high in the back first, making sure to work the bottom piece into the coal bed to insure a solid stack. Then load 2-3 pieces in the front, making sure to work the bottom pieces into the coal bed to insure a solid stack once all the wood is loaded. Leave at least a 1 inch air gap between the two stacks to insure good air flow around the wood and at least a ½ inch back from the dog house (primary air).**
- **Leave the door slightly open 2 inches for up to 3 minutes or until a good strong flame is present. Then close the door, latching it lightly and push the SBT button.**
- **In approximately 5 minutes or when the flame is good and strong shut and latch the door. Then push the SBT button.**

## **2.2 - Test Data by Run**

Run 1 (High) Notes & Results

Run 1 (Med) Notes & Results

Run 2 (High) Notes & Fuel

Run 2 (Low) Notes & Results

## ASTM E3053 / ASTM E2515 Emissions Results

Manufacturer: HHT Mt. Pleasant  
 Model: Pioneer III  
 Project No.: 0061WF102E  
 Tracking No.: N/A  
 Run: 1 High  
 Test Date: 01/29/19

Technician Signature: 

Integrated Test Run	
Particulate Emission Rate	4.44 g/hr
Total Particulate Emissions - $E_T$	13.11 g
Emissions Factor	0.80 g/kg
CSA B415 Efficiency	69.6% HHV

First Hour Emissions	
Particulate Emission Rate	8.58 g/hr
Total Particulate Emissions - $E_T$	8.58 g
Emissions Factor	-1.04 g/kg

Burn Rate	5.53 kg/hr dry
Average Tunnel Temperature	223 degrees F
Avg. Velocity in Dilution Tunnel - $v_s$	14.64 ft/second
Avg. Flow Rate in Dilution Tunnel - $Q_{sd}$	7736.1 dscf/hour
Average $\Delta p$	0.044 inches H2O
Average $\Delta H$	1.39 inches H2O
Total Time of Test	177 minutes

## ASTM E3053 / ASTM E2515 Emissions Results

Manufacturer: HHT Mt. Pleasant  
 Model: Pioneer III  
 Project No.: 0061WF102E  
 Tracking No.: N/A  
 Run: 1 High  
 Test Date: 01/29/19

Technician Signature: 

	1 <sup>st</sup> Hour	Sample Train 1	Sample Train 2	Sample	Unit
Total Sample Volume - $V_m$	9.004	26.627	25.959	N/A	ft <sup>3</sup>
Average Gas Meter Temperature	75.27	75.27	77.83		°F
Sample Volume (Std. Conditions) - $V_{mstd}$	8.565	25.329	24.826		dsf <sup>3</sup>
Total Particulates - $m_n$	9.5	14.2	14.6		mg
Particulate Concentration - $C_r/C_s$	1.109E-03	5.61E-04	5.88E-04		g/dsf <sup>3</sup>
Total Particulate Emissions - $E_T$	8.58	12.79	13.42		g
Particulate Emission Rate	8.58	4.34	4.55		g/hr
Emissions Factor	-1.04	0.78	0.82		g/kg
Delta from Avg. Particulate Emissions		0.31	0.31		g

### Quality Checks

Filter Temps 80 - 90 °F	OK	Ambient Temp (55-90°F)	OK
Filter Face Velocity	OK	Negative Probe Weight	OK
Leakage Rate	OK	Pro-Rate Variation	CHECK 10 MIN.
		Dual Train Comparison	OK

### CSA B415.1 Results - Test Load

**Manufacturer:** HHT Mt. Pleasant                      **Control #:** 0061WF102E  
**Model:** Pioneer III    **Test Duration:** 150  
**Date:** 01/29/19    **Output Category:** High  
**Run:** 1 High

Test Results in Accordance with CSA B415.1-09

	HHV Basis	LHV Basis
Overall Efficiency	69.6%	74.7%
Combustion Efficiency	97.4%	97.4%
Heat Transfer Efficiency	71%	76.8%

	kJ/h	BTU/h
Output Rate	76,663	72,724
Input Rate	110,201	104,538

	kg/h	lb/h
Burn Rate	5.38	11.85

	dry kg	dry lb
Test Load Weight	13.44	29.62

MC wet (%)	17.49
MC dry (%)	21.20
Particulate (g )	24.83
CO (g)	529
Test Duration (h)	2.50

	g/MJ Output	g/kg Dry Fuel	g/h	lb/MM Btu Output
Particulate Emissions	0.13	1.85	9.93	0.30
CO Emissions	2.76	39.37	211.65	6.42
Air/Fuel Ratio (A/F)	9.64			

**VERSION                      2-2                      12/14/2009                      Modified to fit this Format**

Client: HHT  
 Model: Pioneer III  
 Project: 0061WF102E

### High Burn 1

Required Load Density (WB)	10	lb/ft <sup>3</sup>
Usable Firebox Volume	4.00	ft <sup>3</sup>
Total Load Target	40	lb

### Load Parameters

	Target Range (lb)
Total Load	42 - 38
Core Load	18 - 26; 6 - 10 ea.
Remainder Load	14 - 22; 4 - 22 ea.
Kindling	0 - 7.66
Startup Fuel	0 - 11.49
Residual Startup Weight	3.83 - 7.66

### Load Inputs

	Weight (lb)	Moisture Readings (% DB)			Average
		1	2	3	
Core Load Piece 1	6.6	24.5	16	16.5	19.0
Core Load Piece 2	7.8	24.5	20.5	16	20.3
Core Load Piece 3	7.8	24	20.5	18	20.8
Remainder Load Piece 1	7.5	25.5	21	15.5	20.7
Remainder Load Piece 2	8.6	25	29	19.5	24.5
Remainder Load Piece 3					
Test Load Total	38.30				
Core Total	22.20				
Remainder Total	16.10				
Kindling	6.7	6.5	9	6.5	7.3
Startup Fuel	11.3	25	25.5	22	24.2
Residual Startup Weight	7.5				
Actual Fuel Load Ending	3.5				

### Input Validations

	Moisture (% DB)		Weight (lb, WB)	
	Moisture	Moisture	Weight	Weight
Core Load Piece 1	19.0	In Range	6.6	In Range
Core Load Piece 2	20.3	In Range	7.8	In Range
Core Load Piece 3	20.8	In Range	7.8	In Range
Remainder Load Piece 1	20.7	In Range	7.5	In Range
Remainder Load Piece 2	24.5	In Range	8.6	In Range



**Client:** HHT  
**Model:** Pioneer III  
**Project:** 0061WF102E

**High Burn 1**

Remainder Load Piece 3				
Total Load % DB	21.2	In Range		
Residual Startup Weight			7.5	In Range
Actual Fuel Load Ending			3.5	Valid Test

Core % of Total Wt.	58%	In Range	45-65%
Remainder % of Total Wt.	42%	In Range	35-55%
Actual Load % of Target	96%	In Range	95-105%

**Additional Information**

WB Moisture	17.5	%
Total Test Load WB	31.61	kg
Total Fuel Burned	28.1	lb
Total Fuel Burned During Test	34.8	≥ 90%
Actual Fuel Load Density	9.6	lb/ft <sup>3</sup>

### ASTM E2780 Wood Heater Run Sheets

Client: HHT Project Number: 0061WF102E Run Number: I High

Model: Pioneer III Tracking Number: N/A Date: 1/29/2019

Test Crew: Aaron Kravitz

OMNI Equipment ID numbers: 132, 283A, 296-T32, 371, 372, 431, 559, 592, 635, 637

#### Wood Heater Run Notes

##### Air Control Settings

Primary:

Thermostat programmed to call for heat at all times

Secondary: Controlled w/

primary

Tertiary/Pilot: Fixed

Fan: Auto

##### Test Notes

Start up procedures & Timeline:

*High:*

Ignition: 60 s w/ torch

Residual: 2.8 lb

Startup Fuel: Loaded @ 9 min

Residual: 7.5 lb

Test Loading: Fuel loaded from ET= 26-27

Door closed at ET=30

Air set, boost activated ET=30

*Med/Low:*

Coal Bed: N/A

Test Loading: \_\_\_\_\_

\_\_\_\_\_

\_\_\_\_\_

\_\_\_\_\_

Time	Notes
34:00	Changed Filter A
35:00	Changed Filter B
60:00	Changed Filter A
68:00	Changed Filter B

Technician Signature: 

Date: 2/4/19

### ASTM E2780 Wood Heater Run Sheets

Client: HHT Project Number: 0061WF102E Run Number: I High  
 Model: Pioneer III Tracking Number: N/A Date: 1/29/2019  
 Test Crew: Aaron Kravitz  
 OMNI Equipment ID numbers: 132, 283A, 296-T32, 371, 372, 431, 559, 592, 635, 637

#### ASTM E2515 Sampling Information

Test Location: HHT Mt. Pleasant Clock Time @ ET=0: 12:12  
 Span Gas Concentrations: CO<sub>2</sub>(%): 15.05 CO(%): 5.093 CO(ppm): N/A

Test Run Validation Checks	Pre Test	Post Test
Zero Stack Gas Leakage	✓	✓
Zero Pitot Line Leakage	✓	✓
Zero Induced Draft	✓	
100% Smoke Capture	✓	

Test Run Validation Measurements	Pre Test		Post Test	
Scale Audit (lbs)	10.0		10.0	
CO <sub>2</sub> % (Zero/Span)	0.12	15.16	0.14	14.93
CO % (Zero/Span)	0.009	5.099	0.011	5.047
CO ppm (Zero/Span)	N/A			
Sample A Leakage (cfm @ "Hg)	0 @ -16		0.001 @ -14	
Sample B Leakage (cfm @ "Hg)	0.002 @ -13		0 @ -13	
Room Air Velocity (ft/min)	< 50		< 50	
Barometric Pressure ("Hg)	29.4		29.4	
Relative Humidity (%)	34%		41%	
Tunnel Static ("H <sub>2</sub> O)	-0.2		-0.2	

#### Last Cleaning Dates

Flue Pipe	1/29/19	A
Dilution Tunnel	1/28/19	A
Sample Dryers	1/18/19	A

#### Dilution Tunnel Traverse

Traverse Point	1	2	3	3	4	5	6	7	Center
Δp ("H <sub>2</sub> O)	0.040	0.042	0.046	0.038	0.034	0.044	0.046	0.047	0.050
T (°F)	74	74	74	74	74	74	74	74	74

Technician Signature: 

Date: 2/4/19

### Wood Heater Test Data - ASTM E3053 / ASTM E2515

Run: 1 High  
 Manufacturer: HHT Mt. Pleasant  
 Model: Pioneer III  
 Tracking No.: N/A  
 Project No.: 0061WF102E  
 Test Date: 29-Jan-19  
 Beginning Clock Time: 12:12

Total Sampling Time: 177 min  
 Recording Interval: 1 min  
 Background Sample Volume:          cubic feet

Meter Box Y Factor: 0.974 (1) 0.983 (2)          (Amb)

Barometric Pressure:          Begin          Middle          End          Average          "Hg  
29.60 29.50 29.50 29.53

PM Control Modules: 371/372  
 Dilution Tunnel MW(dry): 29.00 lb/lb-mole  
 Dilution Tunnel MW(wet): 28.78 lb/lb-mole  
 Dilution Tunnel H2O: 2.00 percent  
 Dilution Tunnel Static: -0.200 "H<sub>2</sub>O  
 Tunnel Area: 0.1963 ft<sup>2</sup>  
 Pitot Tube Cp: 0.99

Avg. Tunnel Velocity: 14.64 ft./sec.  
 Initial Tunnel Flow: 154.7 scfm  
 Average Tunnel Flow: 128.9 scfm  
 Post-Test Leak Check (1): 0.000 cfm @ -10 in. Hg  
 Post-Test Leak Check (2): 0.000 cfm @ -14 in. Hg

Velocity Traverse Data									
	Pt.1	Pt.2	Pt.3	Pt.4	Pt.5	Pt.6	Pt.7	Pt.8	Center
Initial dP	0.040	0.042	0.046	0.038	0.034	0.044	0.046	0.047	0.050
Temp:	74	74	74	74	74	74	74	74	74
V <sub>strav</sub>	13.74			ft/sec			V <sub>scnt</sub>	14.99	
F <sub>p</sub>	0.917			ft/sec					

Run:	Particulate Sampling Data												Fuel Weight (lb)		Temperature Data (°F)							Stack Gas Data				
	Elapsed Time (min)	Gas Meter 1 (ft <sup>3</sup> )	Gas Meter 2 (ft <sup>3</sup> )	Sample Rate 1 (cfm)	Sample Rate 2 (cfm)	Orifice dH 1 ("H <sub>2</sub> O)	Meter Temp 1 (°F)	Meter Vacuum 1 ("Hg)	Orifice dH 2 ("H <sub>2</sub> O)	Meter Temp 2 (°F)	Meter Vacuum 2 ("Hg)	Dilution Tunnel (°F)	Tunnel Center dP	Pro. Rate 1	Pro. Rate 2	Scale Reading	Weight Change	Stack	Filter 1	Dryer 1	Filter 2	Dryer 2	Ambient	Avg. Surface	Draft ("H <sub>2</sub> O)	CO <sub>2</sub> (%)
0	0.000	0.000			0.81	73	0.67	0.05	74	0.00	74	0.050			6.8		73	84	71	83	72	72	72	0.021	0.13	0.080
1	0.142	0.122	0.14	0.12	1.43	73	0.94	1.71	74	1.20	129	0.049	84	74	6.7	-0.1	146	83	72	83	72	73	74	0.049	0.90	0.130
2	0.293	0.264	0.15	0.14	1.34	73	0.93	1.60	74	1.30	296	0.046	104	101	5.9	-0.8	417	85	72	85	72	72	84	0.083	2.07	0.140
3	0.434	0.396	0.14	0.13	1.17	73	1.14	1.38	75	1.20	306	0.044	100	96	5.0	-0.9	674	90	72	88	72	72	109	0.079	4.61	0.110
4	0.582	0.533	0.15	0.14	1.34	73	1.44	1.50	75	1.70	455	0.042	117	112	3.1	-1.9	958	88	72	89	72	72	141	0.087	6.78	0.060
5	0.729	0.665	0.15	0.13	1.33	73	1.43	1.50	75	1.60	334	0.041	110	101	3.7	0.6	826	89	72	89	73	72	171	0.081	9.99	0.030
6	0.876	0.807	0.15	0.14	1.38	73	1.45	1.77	75	1.70	286	0.043	104	103	3.4	-0.3	732	89	72	87	73	72	194	0.077	10.36	0.030
7	1.027	0.952	0.15	0.15	1.41	73	1.42	1.76	75	1.70	250	0.043	104	103	3.2	-0.2	656	90	73	86	73	72	208	0.074	7.89	0.070
8	1.177	1.098	0.15	0.15	1.41	73	1.47	1.77	75	1.70	222	0.044	100	100	3.1	-0.1	594	87	73	84	74	72	216	0.072	4.21	0.450
9	1.329	1.244	0.15	0.15	1.43	73	1.49	1.76	75	1.60	204	0.044	100	99	3.0	-0.1	555	84	73	83	74	73	221	0.071	3.96	1.140
10	1.480	1.389	0.15	0.15	1.38	73	1.43	1.69	75	1.30	306	0.045	106	104	14.0	11.0	528	84	73	82	74	73	223	0.076	3.77	2.820
11	1.628	1.531	0.15	0.14	1.35	73	1.56	1.66	75	1.90	351	0.044	108	106	13.4	-0.6	543	85	73	83	74	73	223	0.074	10.24	0.230
12	1.782	1.674	0.15	0.14	1.43	73	1.65	1.75	75	1.60	385	0.044	115	109	11.8	-1.6	578	87	73	84	74	73	222	0.081	9.73	0.170
13	1.933	1.817	0.15	0.14	1.41	73	1.70	1.70	75	1.60	343	0.041	114	110	12.2	0.4	642	89	73	87	74	73	229	0.078	9.01	0.120
14	2.082	1.965	0.15	0.15	1.52	73	1.92	1.83	75	2.00	350	0.042	111	113	11.8	-0.4	697	90	73	89	74	73	240	0.080	8.12	0.100
15	2.236	2.111	0.15	0.15	1.42	74	1.90	1.74	76	2.30	373	0.042	116	113	11.3	-0.5	759	89	73	89	74	74	256	0.082	7.26	0.090
16	2.374	2.255	0.14	0.14	1.05	74	2.45	1.71	76	2.10	337	0.042	102	109	10.8	-0.5	699	89	73	90	74	73	270	0.078	6.42	0.080
17	2.504	2.397	0.13	0.14	1.25	74	2.65	1.68	76	2.30	323	0.042	95	107	10.3	-0.5	714	88	74	90	74	73	278	0.082	5.73	0.090
18	2.660	2.542	0.16	0.15	1.52	74	2.98	1.78	76	2.20	272	0.043	109	104	10.0	-0.3	666	88	74	90	75	73	288	0.075	5.27	0.120
19	2.812	2.685	0.15	0.14	1.39	74	3.06	1.66	76	2.30	268	0.043	106	103	9.6	-0.4	684	89	74	87	75	73	294	0.081	4.93	0.200
20	2.949	2.814	0.14	0.13	1.51	74	3.35	1.85	76	2.40	266	0.042	97	93	9.2	-0.4	711	89	74	86	75	73	305	0.080	4.81	0.300
21	3.103	2.961	0.15	0.15	1.53	74	3.39	1.64	76	2.70	257	0.042	108	106	8.9	-0.3	703	89	75	87	75	73	316	0.080	5.32	0.420
22	3.258	3.104	0.16	0.14	1.57	74	3.31	1.90	76	4.40	253	0.043	107	101	8.5	-0.4	696	89	75	87	75	73	327	0.079	6.86	0.530
23	3.411	3.252	0.15	0.15	1.50	74	2.88	1.83	76	3.90	246	0.044	104	103	8.2	-0.3	695	89	75	86	75	74	337	0.079	8.47	0.670
24	3.566	3.396	0.16	0.14	1.57	74	2.71	1.86	76	3.80	241	0.045	104	99	7.9	-0.3	696	89	75	86	75	74	347	0.080	9.53	0.860
25	3.715	3.539	0.15	0.14	1.48	74	2.50	1.92	76	3.50	240	0.045	100	98	7.7	-0.2	699	89	75	86	75	74	354	0.079	10.19	1.100
26	3.861	3.677	0.15	0.14	1.49	74	2.48	1.83	76	2.90	238	0.047	95	93	7.4	-0.3	701	88	74	85	75	74	361	0.080	10.98	1.140
27	3.998	3.808	0.14	0.13	1.45	74	2.52	1.78	76	3.00	341	0.049	94	92	39.3	31.9	686	88	74	86	75	75	364	0.080	11.82	0.920
28	4.117	3.920	0.12	0.11	1.44	74	2.72	1.76	76	3.30	340	0.047	83	81	37.7	-1.6	556	87	74	85	75	75	355	0.070	12.34	0.740
29	4.216	4.012	0.10	0.09	1.35	74	2.96	1.51	76	3.70	361	0.046	71	68	37.2	-0.5	539	88	74	86	75	74	346	0.074	12.62	0.710
30	4.307	4.080	0.09	0.07	1.11	74	3.52	0.98	76	4.80	359	0.044	67	51	36.4	-0.8	603	89	74	85	75	74	341	0.081	12.90	0.740
31	4.637	4.320	0.33	0.24	1.14	74	3.74	1.93	76	6.90	314	0.044	235	175	36.1	-0.3	660	89	74	86	75	74	344	0.078	13.25	0.770
32	4.783	4.477	0.15	0.16	0.99	74	6.03	1.05	76	9.10	258	0.044	100	111	35.8	-0.3	619	89	74	88	75	74	347	0.074	13.48	0.730
33	4.884	4.578	0.10	0.10	0.38	74	16.46	0.48	76	16.80	234	0.047	66	68	35.6	-0.2	514	89	74	89	75	74	346	0.070	12.98	0.570
34	4.962	4.653	0.08	0.07	0.59	74	15.39	0.35	76	17.40	208	0.045	51	50	35.4	-0.2	523	84	74	88	74	74	345	0.072	11.64	0.400
35	5.152	4.717	0.19	0.06	1.26	74	1.01	0.28	76	17.80	200	0.045	123	43	35.2	-0.2	530	82	73	87	74	74	346	0.072	9.97	0.290
36	5.308	4.829	0.16	0.11	1.44	74	1.36	2.48	76	1.50	189	0.045	101	74	35.0	-0.2	523	84	72	85	73	73	346	0.072	8.53	0.300
37	5.460	4.973	0.15	0.14	1.43	74	1.34	1.81	76	1.70	182	0.046	96	94	34.8	-0.2	515	84	72	83	73	74	346	0.071	7.48	0.480
38	5.612	5.142	0.15	0.17	1.42	74	1.37	1.80	76	1.60	178	0.046	96	110	34.6	-0.2	506	84	72	83	73	74	346	0.071	7.02	0.640
39	5.764	5.290	0.15	0.15	1.42	74	1.28	1.81	76	1.20	172	0.047	95	95	34.4	-0.2	495	84	72	80	73	74	344	0.071	7.23	0.680
40	5.919	5.439	0.15	0.15	1.50	74	1.46	1.85	76	1.10	169	0.046	97	96	34.2	-0.2	485	84	72	80	73	74	342	0.069	7.44	0.710
41	6.085	5.590	0.17	0.15	1.49	74	1.32	1.91	76	1.30	166	0.046	104	97	34.0	-0.2	481	84	72	81	73	74	342	0.069	7.38	0.730
42	6.251	5.744	0.17	0.15	1.50	74	1.27	1.93	76	1.10	167	0.046	104	99	33.8	-0.2	488	85	72	82	73	74	342	0.071	7.30	0.750
43	6.415	5.895	0.16	0.15	1.44	74	1.27	1.85	76	1.30	173	0.046	103	98	33.5	-0.3	506	86	72	83	73	74	343	0.073	7.34	0.760
44	6.573	6.041	0.16	0.15	1.33	74	1.32	1.73	76	1.50	181	0.046	100	95	33.2	-0.3	541	88	72	83	73	73	346	0.076	7.35	0.770
45	6.728	6.185	0.15	0.14	1.27	74	1.35	1.67	76	1.30	186	0.046	99	94	33.0	-0.2	570	86	72	84	73	74	351	0.075		

Run:	Particulate Sampling Data													Fuel Weight (lb)		Temperature Data (°F)							Stack Gas Data			
	Elapsed Time (min)	Gas Meter 1 (ft³)	Gas Meter 2 (ft³)	Sample Rate 1 (cfm)	Sample Rate 2 (cfm)	Orifice dH 1 (H <sub>2</sub> O)	Meter Temp 1 (°F)	Meter Vacuum 1 (°Hg)	Orifice dH 2 (H <sub>2</sub> O)	Meter Temp 2 (°F)	Meter Vacuum 2 (°Hg)	Dilution Tunnel (°F)	Tunnel Center dP	Pro. Rate 1	Pro. Rate 2	Scale Reading	Weight Change	Stack	Filter 1	Dryer 1	Filter 2	Dryer 2	Ambient	Avg. Surface	Draft (H <sub>2</sub> O)	CO <sub>2</sub> (%)
52	7.806	7.248	0.15	0.17	1.41	75	1.88	1.74	77	1.40	199	0.044	99	112	31.1	-0.2	607	87	73	85	74	73	372	0.076	9.64	0.620
53	7.957	7.423	0.15	0.18	1.45	75	1.94	1.73	77	1.40	200	0.045	98	117	30.8	-0.3	612	88	73	85	74	75	375	0.077	10.46	0.590
54	8.109	7.567	0.15	0.14	1.39	75	1.97	1.71	77	1.30	202	0.045	99	96	30.6	-0.2	618	88	73	85	74	74	377	0.078	10.86	0.560
55	8.257	7.713	0.15	0.15	1.33	75	2.17	1.79	77	1.30	204	0.046	95	96	30.2	-0.4	624	89	73	85	74	74	380	0.078	11.08	0.510
56	8.407	7.859	0.15	0.15	1.40	75	2.38	1.74	77	1.40	204	0.046	97	96	30.0	-0.2	629	89	73	85	74	74	382	0.077	11.24	0.460
57	8.557	8.003	0.15	0.14	1.40	75	3.14	1.80	77	1.80	208	0.046	97	95	29.7	-0.3	635	89	73	86	74	74	382	0.079	11.40	0.430
58	8.695	8.147	0.14	0.14	1.01	75	3.85	1.60	77	2.00	210	0.043	92	99	29.4	-0.3	641	89	74	86	74	74	383	0.079	11.52	0.420
59	8.854	8.292	0.16	0.15	1.59	75	5.30	1.96	77	2.40	213	0.045	104	98	29.1	-0.3	651	90	74	86	74	74	384	0.079	11.60	0.440
60	9.004	8.441	0.15	0.15	1.21	75	6.03	1.74	77	2.70	218	0.045	99	101	28.8	-0.3	660	90	74	86	74	74	385	0.080	11.70	0.450
61	9.203	8.578	0.20	0.14	3.32	75	1.93	1.34	77	3.10	222	0.045	131	93	28.5	-0.3	668	87	74	86	74	74	387	0.080	11.83	0.450
62	9.389	8.724	0.19	0.15	1.49	75	0.90	1.78	77	3.00	225	0.044	124	100	28.1	-0.4	677	88	73	86	74	74	390	0.081	11.99	0.450
63	9.534	8.834	0.15	0.11	1.48	75	0.95	1.13	77	3.90	228	0.044	97	76	27.8	-0.3	684	88	73	86	74	75	392	0.080	12.23	0.470
64	9.679	8.967	0.15	0.13	1.46	75	0.91	1.80	77	6.40	231	0.043	98	93	27.4	-0.4	688	88	73	85	74	73	393	0.081	12.51	0.520
65	9.822	9.097	0.14	0.13	1.44	75	0.92	1.40	77	6.30	232	0.044	96	90	27.1	-0.3	693	88	73	85	74	75	395	0.081	12.82	0.580
66	9.965	9.322	0.14	0.23	1.44	75	1.05	3.20	77	2.30	235	0.044	96	156	26.7	-0.4	697	88	73	84	74	74	397	0.080	13.13	0.640
67	10.109	9.518	0.14	0.20	1.43	75	1.01	1.86	77	1.30	235	0.045	96	134	26.4	-0.3	698	88	73	86	74	75	398	0.080	13.37	0.650
68	10.250	9.659	0.14	0.14	1.42	75	1.02	1.86	77	1.40	236	0.044	95	98	26.1	-0.3	701	88	74	87	74	75	400	0.080	13.54	0.630
69	10.392	9.810	0.14	0.15	1.41	75	0.95	1.87	77	1.00	237	0.045	95	103	25.8	-0.3	702	88	74	87	74	74	402	0.081	13.69	0.630
70	10.543	9.931	0.15	0.12	1.40	75	1.08	1.84	77	1.30	238	0.043	103	85	25.5	-0.3	707	89	74	87	74	75	404	0.081	13.77	0.630
71	10.693	10.110	0.15	0.18	1.38	75	1.04	1.86	79	1.20	240	0.043	103	125	25.1	-0.4	711	89	74	87	74	74	406	0.081	13.81	0.630
72	10.843	10.260	0.15	0.15	1.38	75	0.98	1.83	79	1.10	242	0.043	103	105	24.8	-0.3	719	89	74	87	74	74	409	0.081	13.85	0.630
73	10.991	10.408	0.15	0.15	1.37	75	1.05	1.82	79	1.10	244	0.044	100	103	24.5	-0.3	722	90	74	87	74	76	411	0.081	13.88	0.610
74	11.140	10.556	0.15	0.15	1.35	75	1.11	1.81	79	1.00	244	0.044	101	103	24.2	-0.3	726	90	74	87	74	75	412	0.082	13.94	0.580
75	11.286	10.703	0.15	0.15	1.34	75	1.14	1.79	79	1.00	243	0.046	97	100	23.8	-0.4	727	90	74	87	75	74	414	0.080	14.01	0.540
76	11.433	10.850	0.15	0.15	1.33	75	1.07	1.78	79	1.40	243	0.045	98	101	23.6	-0.2	725	90	74	87	75	75	416	0.082	14.11	0.520
77	11.579	10.997	0.15	0.15	1.31	75	1.14	1.77	79	1.00	244	0.043	100	103	23.2	-0.4	724	90	74	87	75	75	417	0.080	14.23	0.490
78	11.727	11.143	0.15	0.15	1.48	75	1.22	1.82	79	1.40	243	0.043	101	102	23.0	-0.2	722	90	74	87	75	75	418	0.082	14.34	0.470
79	11.882	11.292	0.15	0.15	1.47	75	1.22	1.80	79	1.00	244	0.043	106	104	22.6	-0.4	725	90	74	87	75	74	420	0.081	14.44	0.450
80	12.035	11.429	0.15	0.14	1.42	75	1.23	1.79	79	1.40	244	0.043	105	96	22.3	-0.3	726	89	74	86	75	74	421	0.081	14.50	0.420
81	12.186	11.587	0.15	0.16	1.43	75	1.25	1.79	79	1.40	244	0.043	103	111	22.1	-0.2	722	88	74	86	75	75	422	0.080	14.53	0.390
82	12.338	11.734	0.15	0.15	1.41	75	1.15	1.76	79	1.00	244	0.043	104	103	21.8	-0.3	721	87	74	86	75	75	423	0.081	14.53	0.360
83	12.489	11.880	0.15	0.15	1.40	75	1.28	1.77	79	1.10	243	0.042	105	104	21.4	-0.4	720	87	74	86	75	75	424	0.081	14.49	0.340
84	12.640	12.026	0.15	0.15	1.41	75	1.27	1.76	79	1.00	243	0.043	103	102	21.2	-0.2	719	87	74	86	75	74	425	0.080	14.44	0.330
85	12.791	12.172	0.15	0.15	1.40	75	1.25	1.76	79	1.00	242	0.043	103	102	20.9	-0.3	718	87	74	86	75	75	425	0.081	14.39	0.330
86	12.942	12.319	0.15	0.15	1.38	75	1.24	1.76	79	1.10	242	0.044	102	102	20.6	-0.3	716	87	74	86	75	74	426	0.080	14.39	0.330
87	13.092	12.465	0.15	0.15	1.42	76	1.26	1.76	79	1.30	242	0.040	106	106	20.2	-0.4	716	87	74	86	75	75	427	0.080	14.42	0.320
88	13.244	12.612	0.15	0.15	1.40	75	1.21	1.89	79	1.30	241	0.044	103	102	20.0	-0.2	716	87	74	86	75	76	428	0.080	14.46	0.320
89	13.394	12.763	0.15	0.15	1.40	75	1.22	1.87	79	1.40	241	0.041	105	108	19.7	-0.3	714	88	74	86	75	74	429	0.080	14.48	0.310
90	13.545	12.914	0.15	0.15	1.39	76	1.28	1.85	79	1.50	239	0.044	102	104	19.4	-0.3	713	88	74	86	75	76	430	0.081	14.50	0.320
91	13.696	13.063	0.15	0.15	1.41	76	1.27	1.85	79	1.50	240	0.043	103	104	19.1	-0.3	712	88	74	86	75	75	430	0.080	14.51	0.320
92	13.847	13.214	0.15	0.15	1.40	76	1.27	1.85	79	1.50	240	0.044	102	104	18.8	-0.3	712	88	74	86	75	75	431	0.080	14.54	0.320
93	13.998	13.364	0.15	0.15	1.40	76	1.16	1.88	79	1.50	240	0.044	102	104	18.5	-0.3	711	88	74	86	75	74	433	0.080	14.58	0.320
94	14.148	13.514	0.15	0.15	1.40	76	1.18	1.88	79	1.40	238	0.044	101	104	18.1	-0.4	708	89	74	86	75	76	434	0.080	14.62	0.320
95	14.298	13.665	0.15	0.15	1.40	76	1.29	1.87	79	1.20	237	0.043	102	105	17.9	-0.2	707	89	74	86	75	74	434	0.079	14.65	0.320
96	14.448	13.815	0.15	0.15	1.39	76	1.18	1.86	79	1.20	237	0.044	101	103	17.6	-0.3	707	89	74	86	75	75	436	0.080	14.67	0.320
97	14.598	13.966	0.15	0.15	1.39	76	1.18	1.85	79	1.40	236	0.043	102	105	17.3	-0.3	707	89	74	86	75	75	437	0.079	14.68	0.310
98	14.748	14.116	0.15	0.15	1.39	76	1.22	1.86	79	1.50	236	0.043	102	105	17.0	-0.3	706	89	74	87	75	75	438	0.080	14.69	0.310
99	14.898	14.267	0.15	0.15	1.39	76	1.20	1.86	79	1.30	235	0.044	101	104	16.7	-0.3	706	89	74	87	75	75	439	0.080	14.69	0.290
100	15.048	14.416	0.15	0.15	1.38	76	1.22	1.86	79	1.40	235	0.044	101	103	16.5	-0.2	706	89	74	87	75	75	440	0.080	14.69	0.280
101	15.198	14.567	0.15	0.15	1.39	76	1.30	1.87	79	1.20	234	0.044	101	104	16.2	-0.3	705	89	74	87	75	76	441	0.079	14.67	0.270
102	15.348	14.717	0.15	0.15	1.39	76	1.28	1.86	79	1.20	234	0.044	101	103	15.9	-0.3	707	89	74	87	75	76	442	0.080	14.64	0.260
103	15.498	14.867																								

Run:	Particulate Sampling Data														Fuel Weight (lb)		Temperature Data (°F)							Stack Gas Data		
	Elapsed Time (min)	Gas Meter 1 (ft³)	Gas Meter 2 (ft³)	Sample Rate 1 (cfm)	Sample Rate 2 (cfm)	Orifice dH 1 (H <sub>2</sub> O)	Meter Temp 1 (°F)	Meter Vacuum 1 (°Hg)	Orifice dH 2 (H <sub>2</sub> O)	Meter Temp 2 (°F)	Meter Vacuum 2 (°Hg)	Dilution Tunnel (°F)	Tunnel Center dP	Pro. Rate 1	Pro. Rate 2	Scale Reading	Weight Change	Stack	Filter 1	Dryer 1	Filter 2	Dryer 2	Ambient	Avg. Surface	Draft (H <sub>2</sub> O)	CO <sub>2</sub> (%)
118	17.728	17.092	0.15	0.15	1.33	76	1.23	1.77	79	1.60	231	0.044	99	101	11.4	-0.3	706	89	74	86	75	77	463	0.080	15.09	0.360
119	17.875	17.239	0.15	0.15	1.34	76	1.22	1.77	79	1.50	232	0.044	99	101	11.2	-0.2	708	89	74	85	75	75	465	0.079	15.13	0.350
120	18.022	17.385	0.15	0.15	1.34	76	1.34	1.77	79	1.60	231	0.046	96	98	10.9	-0.3	708	89	74	85	75	77	467	0.080	15.11	0.320
121	18.171	17.532	0.15	0.15	1.42	76	1.29	1.77	79	1.60	230	0.046	98	99	10.7	-0.2	707	89	74	85	75	76	468	0.079	15.02	0.290
122	18.322	17.678	0.15	0.15	1.41	76	1.37	1.76	79	1.30	230	0.044	101	100	10.4	-0.3	709	89	74	85	75	76	469	0.080	14.92	0.270
123	18.473	17.824	0.15	0.15	1.41	76	1.42	1.76	79	1.20	231	0.044	101	100	10.2	-0.2	712	89	74	85	75	76	470	0.079	14.81	0.260
124	18.625	17.970	0.15	0.15	1.40	76	1.39	1.76	79	1.60	231	0.044	102	100	9.9	-0.3	713	89	74	85	75	76	472	0.079	14.74	0.260
125	18.775	18.115	0.15	0.15	1.40	76	1.44	1.75	79	1.70	230	0.044	100	100	9.7	-0.2	711	89	74	85	75	76	472	0.078	14.72	0.270
126	18.925	18.261	0.15	0.15	1.40	76	1.44	1.75	79	1.60	229	0.045	99	99	9.5	-0.2	710	89	74	85	75	77	473	0.079	14.71	0.270
127	19.077	18.406	0.15	0.15	1.40	76	1.39	1.75	79	1.40	227	0.047	98	96	9.3	-0.2	707	89	74	86	75	76	473	0.078	14.66	0.280
128	19.227	18.551	0.15	0.15	1.39	76	1.34	1.72	79	1.20	227	0.046	98	97	9.1	-0.2	706	88	74	86	75	77	474	0.079	14.58	0.290
129	19.378	18.698	0.15	0.15	1.39	76	1.45	1.78	79	1.20	224	0.046	98	98	8.8	-0.3	704	88	74	86	74	76	473	0.078	14.55	0.290
130	19.528	18.844	0.15	0.15	1.40	76	1.36	1.79	79	1.60	223	0.045	99	99	8.5	-0.3	698	88	74	86	74	76	473	0.078	14.53	0.270
131	19.678	18.992	0.15	0.15	1.40	76	1.32	1.79	79	1.30	222	0.044	100	101	8.4	-0.1	692	88	74	86	74	76	472	0.078	14.51	0.250
132	19.830	19.140	0.15	0.15	1.40	76	1.31	1.84	79	1.80	220	0.045	100	100	8.3	-0.1	686	88	74	86	74	76	472	0.077	14.46	0.230
133	19.980	19.289	0.15	0.15	1.40	76	1.34	1.83	79	1.40	218	0.045	98	100	8.1	-0.2	681	88	74	86	74	76	471	0.077	14.36	0.220
134	20.130	19.439	0.15	0.15	1.40	76	1.30	1.84	79	1.70	216	0.045	98	101	7.9	-0.2	673	88	74	86	74	77	471	0.077	14.24	0.210
135	20.281	19.588	0.15	0.15	1.39	76	1.45	1.84	79	1.20	212	0.046	98	99	7.7	-0.2	665	89	74	86	74	76	470	0.077	14.08	0.200
136	20.431	19.739	0.15	0.15	1.41	76	1.41	1.83	79	1.30	208	0.047	96	99	7.5	-0.2	657	89	74	86	74	77	470	0.077	13.91	0.190
137	20.582	19.889	0.15	0.15	1.40	76	1.41	1.84	79	1.50	207	0.045	98	100	7.4	-0.1	650	89	74	86	74	76	470	0.076	13.73	0.180
138	20.733	20.039	0.15	0.15	1.40	76	1.45	1.85	79	1.30	205	0.045	98	100	7.2	-0.2	643	90	74	86	74	78	470	0.076	13.56	0.170
139	20.884	20.190	0.15	0.15	1.40	76	1.32	1.84	79	1.60	202	0.046	97	99	7.0	-0.2	637	90	74	86	74	78	470	0.075	13.40	0.160
140	21.035	20.339	0.15	0.15	1.41	76	1.39	1.85	79	1.40	201	0.046	97	98	6.8	-0.2	631	90	74	86	74	77	470	0.075	13.21	0.150
141	21.186	20.489	0.15	0.15	1.40	76	1.36	1.86	79	1.80	199	0.046	97	98	6.7	-0.1	626	90	73	85	74	77	470	0.075	12.98	0.140
142	21.338	20.640	0.15	0.15	1.40	76	1.32	1.84	79	1.80	198	0.045	98	100	6.5	-0.2	622	90	73	85	74	76	470	0.076	12.76	0.140
143	21.489	20.790	0.15	0.15	1.41	76	1.31	1.84	79	1.50	197	0.044	99	100	6.3	-0.2	618	90	73	85	74	76	470	0.075	12.57	0.130
144	21.640	20.941	0.15	0.15	1.41	76	1.29	1.85	79	1.60	195	0.043	100	102	6.2	-0.1	615	90	73	85	74	77	471	0.075	12.40	0.130
145	21.792	21.091	0.15	0.15	1.41	76	1.28	1.85	79	1.40	194	0.042	101	103	6.1	-0.1	611	90	73	85	74	76	471	0.075	12.25	0.130
146	21.943	21.241	0.15	0.15	1.42	76	1.44	1.84	79	1.80	190	0.046	96	98	5.9	-0.2	603	90	73	84	74	77	471	0.073	12.13	0.130
147	22.095	21.391	0.15	0.15	1.41	76	1.36	1.86	79	1.30	188	0.045	98	99	5.8	-0.1	595	89	73	84	74	77	471	0.073	12.01	0.130
148	22.247	21.541	0.15	0.15	1.41	76	1.31	1.86	79	1.80	186	0.044	98	100	5.6	-0.2	588	89	73	84	74	76	470	0.073	11.92	0.140
149	22.399	21.692	0.15	0.15	1.42	76	1.34	1.84	79	1.50	184	0.045	97	99	5.5	-0.1	582	89	73	85	73	77	470	0.073	11.84	0.140
150	22.551	21.843	0.15	0.15	1.42	76	1.30	1.84	79	1.70	181	0.046	96	98	5.4	-0.1	576	89	73	85	73	77	470	0.073	11.78	0.140
151	22.703	21.994	0.15	0.15	1.43	77	1.32	1.87	79	1.60	180	0.045	97	99	5.2	-0.2	572	89	73	85	73	76	469	0.072	11.72	0.140
152	22.855	22.146	0.15	0.15	1.42	76	1.35	1.87	79	1.30	179	0.044	98	100	5.1	-0.1	567	89	73	85	73	75	469	0.072	11.64	0.130
153	23.007	22.296	0.15	0.15	1.43	76	1.29	1.88	79	1.20	178	0.044	98	99	5.0	-0.1	563	89	73	85	73	75	469	0.072	11.51	0.130
154	23.160	22.447	0.15	0.15	1.43	76	1.35	1.88	79	1.30	177	0.044	98	100	4.9	-0.1	557	88	73	85	73	75	468	0.070	11.36	0.120
155	23.312	22.599	0.15	0.15	1.43	76	1.43	1.87	79	1.50	174	0.044	98	100	4.8	-0.1	550	88	73	85	73	77	467	0.070	11.21	0.110
156	23.466	22.751	0.15	0.15	1.43	76	1.41	1.86	79	1.60	171	0.044	99	100	4.7	-0.1	541	88	72	85	73	74	466	0.070	11.09	0.110
157	23.619	22.903	0.15	0.15	1.44	77	1.35	1.89	79	1.50	168	0.044	98	100	4.6	-0.1	531	88	72	85	73	76	464	0.069	11.00	0.110
158	23.773	23.054	0.15	0.15	1.45	77	1.39	1.90	79	1.70	165	0.044	98	99	4.5	-0.1	520	88	72	85	72	76	462	0.069	10.93	0.110
159	23.926	23.206	0.15	0.15	1.37	77	1.22	1.89	79	1.20	161	0.044	97	99	4.5	0.0	509	87	71	85	72	76	460	0.068	10.87	0.110
160	24.075	23.358	0.15	0.15	1.37	77	1.21	1.88	79	1.70	157	0.046	92	96	4.4	-0.1	500	87	69	85	72	77	457	0.068	10.79	0.110
161	24.225	23.510	0.15	0.15	1.37	77	1.28	1.87	79	1.20	156	0.043	96	100	4.3	-0.1	491	86	68	85	71	77	455	0.067	10.68	0.100
162	24.375	23.663	0.15	0.15	1.37	77	1.33	1.88	79	1.50	153	0.045	93	98	4.3	0.0	484	86	67	85	71	77	453	0.067	10.52	0.100
163	24.525	23.815	0.15	0.15	1.39	77	1.23	1.90	79	1.50	151	0.044	94	98	4.2	-0.1	477	86	66	84	71	76	452	0.066	10.30	0.110
164	24.674	23.967	0.15	0.15	1.38	77	1.33	1.90	79	1.40	149	0.044	94	98	4.1	-0.1	470	85	65	84	70	75	450	0.066	10.00	0.110
165	24.825	24.121	0.15	0.15	1.38	77	1.29	1.89	79	1.40	147	0.044	95	99	4.1	0.0	465	85	64	84	70	75	449	0.065	9.71	0.120
166	24.974	24.274	0.15	0.15	1.39	77	1.30	1.91	79	1.20	146	0.043	94	100	4.0	-0.1	462	85	63	84	70	76	448	0.065	9.41	0.130
167	25.125	24.426	0.15	0.15	1.38	77	1.31	1.91	79	1.30	145	0.045	93	97	3.9	-0.1	457	85	62	85	71	76	446	0.065	9.15	0.130
168	25.275	24.579	0.15	0.15	1.38	77	1.22	1.91	79	1.60	144	0.043	95	99	3.9	0.0	453	85	62	85	70	76	445	0.065	8.94	0.120
169	25.426	24.733	0																							

# Wood Heater Test Data - ASTM E2515 - Proportion Rate Validation

Run: **1 High (10 min)**

Manufacturer: HHT Mt. Pleasant

Model: Pioneer III

Tracking No.: N/A

Project No.: 0061WF102E

Test Date: 29-Jan-19

Total Sampling Time: 170 min

Recording Interval: 10 min

Run:	1 High															Particulate Sampling Data														
Elapsed Time (min)	Gas Meter 1 (ft <sup>3</sup> )	Gas Meter 2 (ft <sup>3</sup> )	Sample Rate 1 (cfm)	Sample Rate 2 (cfm)	Orifice dH 1 ("H <sub>2</sub> O)	Meter Temp 1 (°F)	Meter Vacuum 1 ("Hg)	Orifice dH 2 ("H <sub>2</sub> O)	Meter Temp 2 (°F)	Meter Vacuum 2 ("Hg)	Dilution Tunnel (°F)	Tunnel Center dP	sqrt dp	vs1	Pro. Rate 1	Pro. Rate 2														
0	0.000	0.000			0.81	73	0.67	0.05	74	0.00	74	0.050	0.224	13.75																
10	1.480	1.389	0.15	0.14	1.38	73	1.43	1.69	75	1.30	306	0.045	0.212	15.63	109	104														
20	2.949	2.814	0.15	0.14	1.51	74	3.35	1.85	76	2.40	266	0.042	0.205	14.70	108	108														
30	4.307	4.080	0.14	0.13	1.11	74	3.52	0.98	76	4.80	359	0.044	0.210	15.98	104	99														
40	5.919	5.439	0.16	0.14	1.50	74	1.46	1.85	76	1.10	169	0.046	0.214	14.32	106	91														
50	7.503	6.895	0.16	0.15	1.43	75	1.76	1.76	77	1.70	194	0.046	0.214	14.60	106	100														
60	9.004	8.441	0.15	0.15	1.21	75	6.03	1.74	77	2.70	218	0.045	0.212	14.70	103	109														
70	10.543	9.931	0.15	0.15	1.40	75	1.08	1.84	77	1.30	238	0.043	0.207	14.58	110	109														
80	12.035	11.429	0.15	0.15	1.42	75	1.23	1.79	79	1.00	244	0.043	0.207	14.64	107	110														
90	13.545	12.914	0.15	0.15	1.39	76	1.28	1.85	79	1.50	239	0.044	0.210	14.76	106	107														
100	15.048	14.416	0.15	0.15	1.38	76	1.22	1.86	79	1.40	235	0.044	0.210	14.72	106	108														
110	16.544	15.910	0.15	0.15	1.37	76	1.19	1.83	79	1.60	236	0.043	0.207	14.56	106	109														
120	18.022	17.385	0.15	0.15	1.34	76	1.34	1.77	79	1.60	231	0.046	0.214	15.01	101	103														
130	19.528	18.844	0.15	0.15	1.40	76	1.36	1.79	79	1.60	223	0.045	0.212	14.76	104	103														
140	21.035	20.339	0.15	0.15	1.41	76	1.39	1.85	79	1.40	201	0.046	0.214	14.68	101	102														
150	22.551	21.843	0.15	0.15	1.42	76	1.30	1.84	79	1.70	181	0.046	0.214	14.45	100	101														
160	24.075	23.358	0.15	0.15	1.37	77	1.21	1.88	79	1.70	157	0.046	0.214	14.18	98	100														
170	25.575	24.886	0.15	0.15	1.39	77	1.31	1.92	79	1.70	143	0.043	0.207	13.55	99	103														
Avg/Tot	25.575	24.886	0.15	0.15	0.15	8	0.20	0.19	9	0.19	24	0.01	0.212		104	104														

## ASTM E3053 / ASTM E2515 Emissions Results

Manufacturer: HHT Mt. Pleasant  
 Model: Pioneer III  
 Project No.: 0061WF102E  
 Tracking No.: N/A  
 Run: 1 (Med)  
 Test Date: 01/29/19

Technician Signature: 

Integrated Test Run	
Particulate Emission Rate	1.70 g/hr
Total Particulate Emissions - $E_T$	25.60 g
Emissions Factor	1.46 g/kg
CSA B415 Efficiency	68.5% HHV

First Hour Emissions	
Particulate Emission Rate	16.68 g/hr
Total Particulate Emissions - $E_T$	16.68 g
Emissions Factor	2.08 g/kg

Burn Rate	1.16 kg/hr dry
Average Tunnel Temperature	100 degrees F
Avg. Velocity in Dilution Tunnel - $v_s$	14.19 ft/second
Avg. Flow Rate in Dilution Tunnel - $Q_{sd}$	9112.7 dscf/hour
Average $\Delta p$	0.051 inches H2O
Average $\Delta H$	1.38 inches H2O
Total Time of Test	903 minutes



## ASTM E3053 / ASTM E2515 Emissions Results

Manufacturer: HHT Mt. Pleasant  
 Model: Pioneer III  
 Project No.: 0061WF102E  
 Tracking No.: N/A  
 Run: 1 (Med)  
 Test Date: 01/29/19

Technician Signature: 

	1 <sup>st</sup> Hour	Sample Train 1	Sample Train 2	Sample	Unit
Total Sample Volume - $V_m$	8.940	135.417	134.584	N/A	ft <sup>3</sup>
Average Gas Meter Temperature	75.76	75.71	77.45		°F
Sample Volume (Std. Conditions) - $V_{mstd}$	8.468	128.274	128.384		dsf <sup>3</sup>
Total Particulates - $m_n$	15.5	24.1	23.8		mg
Particulate Concentration - $C_r/C_s$	1.830E-03	1.88E-04	1.85E-04		g/dsf <sup>3</sup>
Total Particulate Emissions - $E_T$	16.68	25.77	25.42		g
Particulate Emission Rate	16.68	1.71	1.69		g/hr
Emissions Factor	2.08	1.47	1.45		g/kg
Delta from Avg. Particulate Emissions		0.17	0.17		g

### Quality Checks

Filter Temps 80 - 90 °F	OK	Ambient Temp (55-90°F)	OK
Filter Face Velocity	OK	Negative Probe Weight	OK
Leakage Rate	OK	Pro-Rate Variation	OK
		Dual Train Comparison	OK

## CSA B415.1 Results - Test Load

**Manufacturer:** HHT Mt. Pleasant      **Control #:** 0061WF102E  
**Model:** Pioneer III      **Test Duration:** 903  
**Date:** 01/29/19      **Output Category:** Medium  
**Run:** 1 (Med)

Test Results in Accordance with CSA B415.1-09

	HHV Basis	LHV Basis
Overall Efficiency	68.5%	73.6%
Combustion Efficiency	92.3%	92.3%
Heat Transfer Efficiency	74%	79.8%

	kJ/h	BTU/h
Output Rate	16,340	15,500
Input Rate	23,843	22,618

	kg/h	lb/h
Burn Rate	1.16	2.56

	dry kg	dry lb
Test Load Weight	17.50	38.58

MC wet (%)	18.43
MC dry (%)	22.60
Particulate (g )	128.38
CO (g)	1,955
Test Duration (h)	15.05

	g/MJ Output	g/kg Dry Fuel	g/h	lb/MM Btu Output
Particulate Emissions	0.52	7.33	8.53	1.21
CO Emissions	7.95	111.69	129.91	18.48
Air/Fuel Ratio (A/F)	12.11			

**VERSION      2-2      ~~12/14/2009~~      Modified to fit this Format**

### ASTM E2780 Wood Heater Run Sheets

Client: HHT Project Number: 0061WF102E Run Number: I Medium  
 Model: Pioneer III Tracking Number: N/A Date: 1/31/2019  
 Test Crew: Aaron Kravitz  
 OMNI Equipment ID numbers: 132, 283A, 296-T32, 371, 372, 431, 559, 592, 635, 637

#### Wood Heater Run Notes

#### Air Control Settings

Primary:

Thermostat programed for medium-length off cycle

Secondary: Controlled w/

primary

Tertiary/Pilot: Fixed

Fan: Auto

#### Test Notes

Start up procedures & Timeline:

*High:*

Ignition: \_\_\_\_\_  
 Residual: \_\_\_\_\_  
 Startup Fuel: \_\_\_\_\_  
 Residual: \_\_\_\_\_  
 Test Loading: \_\_\_\_\_  
 \_\_\_\_\_  
 \_\_\_\_\_

*Med/Low:*

Coal Bed: 9.0 lb  
 Test Loading: Fuel loaded by 30 sec  
Door closed at 2:30  
Air set, boost on at 4:00  
 \_\_\_\_\_

Time	Notes
36:00	Changed Filter A (T84S - T85S)
37:00	Changed Filter B (T101BP - T106)
60:00	Changed Filter A (T85S-T101AP)
114:00	Changed Filter B (T106-T107)
249:00	Changed Filter A (T101AP-T108)
884:00	Changed Filter B (T107-T109)

Technician Signature: 

Date: 2/4/19

### ASTM E2780 Wood Heater Run Sheets

Client: HHT Project Number: 0061WF102E Run Number: I Medium  
 Model: Pioneer III Tracking Number: N/A Date: 1/31/2019  
 Test Crew: Aaron Kravitz  
 OMNI Equipment ID numbers: 132, 283A, 296-T32, 371, 372, 431, 559, 592, 635, 637

#### ASTM E2515 Sampling Information

Test Location: HHT Mt. Pleasant Clock Time @ ET=0: 13:40  
 Span Gas Concentrations: CO<sub>2</sub>(%): 15.05 CO(%): 5.093 CO(ppm): N/A

Test Run Validation Checks	Pre Test	Post Test
Zero Stack Gas Leakage	✓	✓
Zero Pitot Line Leakage	✓	✓
Zero Induced Draft	✓	
100% Smoke Capture	✓	

Test Run Validation Measurements	Pre Test		Post Test	
Scale Audit (lbs)	10.0		10.0	
CO <sub>2</sub> % (Zero/Span)	0.12	15.11	0.14	14.93
CO % (Zero/Span)	0.009	5.099	0.011	5.047
CO ppm (Zero/Span)	N/A			
Sample A Leakage (cfm @ "Hg)	0		0.001 @ -14	
Sample B Leakage (cfm @ "Hg)	0.002		0 @ -13	
Room Air Velocity (ft/min)	450		450	
Barometric Pressure ("Hg)	29.4		29.5	
Relative Humidity (%)	41%		39%	
Tunnel Static ("H <sub>2</sub> O)	-0.2		-0.2	

#### Last Cleaning Dates

Flue Pipe	1/29/19
Dilution Tunnel	1/28/19
Sample Dryers	1/18/19

#### Dilution Tunnel Traverse

Traverse Point	1	2	3	3	4	5	6	7	Center
Δp ("H <sub>2</sub> O)	0.040	0.042	0.046	0.038	0.034	0.044	0.046	0.047	0.050
T (°F)	74	74	74	74	74	74	74	74	74

Technician Signature: 

Date: 2/4/19

# Wood Heater Test Data - ASTM E2515 - Proportion Rate Validation

Run: **1 (Med)** (10 min)

Manufacturer: HHT Mt. Pleasant

Model: Pioneer III

Tracking No.: N/A

Project No.: 0061WF102E

Test Date: 29-Jan-19

Total Sampling Time: 900 min

Recording Interval: 10 min

Run:	1 (Med) Particulate Sampling Data															
Elapsed Time (min)	Gas Meter 1 (ft <sup>3</sup> )	Gas Meter 2 (ft <sup>3</sup> )	Sample Rate 1 (cfm)	Sample Rate 2 (cfm)	Orifice dH 1 ("H <sub>2</sub> O)	Meter Temp 1 (°F)	Meter Vacuum 1 ("Hg)	Orifice dH 2 ("H <sub>2</sub> O)	Meter Temp 2 (°F)	Meter Vacuum 2 ("Hg)	Dilution Tunnel (°F)	Tunnel Center dP	sqrt dp	vs1	Pro. Rate 1	Pro. Rate 2
0	0.000	0.000			0.39	76	-0.01	0.59	78	0.50	141	0.048	0.220	14.37		
10	1.527	1.491	0.15	0.15	1.37	76	9.21	2.77	78	10.10	168	0.048	0.219	14.64	108	106
20	2.979	2.952	0.15	0.15	1.35	76	8.31	1.78	78	6.10	240	0.050	0.224	15.77	107	108
30	4.422	4.400	0.14	0.14	1.38	76	11.76	1.83	78	12.60	231	0.051	0.226	15.83	104	105
40	5.937	5.927	0.15	0.15	1.40	76	0.87	1.79	78	0.90	210	0.051	0.226	15.59	108	109
50	7.436	7.409	0.15	0.15	1.39	76	0.93	1.81	78	1.30	165	0.049	0.221	14.70	105	105
60	8.940	8.891	0.15	0.15	1.38	77	0.90	1.81	79	1.30	167	0.049	0.221	14.73	106	105
70	10.446	10.368	0.15	0.15	1.39	77	0.94	1.80	79	1.30	174	0.048	0.220	14.76	107	105
80	11.937	11.848	0.15	0.15	1.34	77	0.98	1.81	79	0.90	185	0.048	0.219	14.84	107	107
90	13.437	13.323	0.15	0.15	1.43	77	1.02	1.76	79	1.70	168	0.049	0.221	14.74	105	104
100	14.949	14.801	0.15	0.15	1.39	77	1.03	1.83	79	1.80	175	0.049	0.221	14.82	107	105
110	16.448	16.275	0.15	0.15	1.36	77	1.11	1.70	79	1.80	174	0.048	0.220	14.76	106	105
120	17.936	17.773	0.15	0.15	1.36	77	1.48	1.85	79	1.00	163	0.049	0.221	14.73	104	105
130	19.418	19.271	0.15	0.15	1.35	77	1.51	1.84	79	1.00	154	0.049	0.221	14.62	103	104
140	20.896	20.761	0.15	0.15	1.36	77	1.53	1.82	79	1.00	148	0.049	0.221	14.50	102	104
150	22.340	22.251	0.14	0.15	3.26	77	7.80	1.82	79	1.10	136	0.049	0.222	14.46	98	102
160	23.912	23.739	0.16	0.15	1.47	77	6.37	1.78	79	1.10	118	0.050	0.223	14.29	105	100
170	25.418	25.217	0.15	0.15	1.57	77	6.37	1.80	79	1.20	106	0.050	0.224	14.23	99	97
180	26.909	26.694	0.15	0.15	1.24	77	6.69	1.76	79	1.20	87	0.051	0.225	14.04	96	95
190	28.401	28.180	0.15	0.15	1.43	77	9.57	1.87	78	1.80	82	0.051	0.225	13.97	96	96
200	29.949	29.673	0.15	0.15	1.40	76	7.95	1.84	78	1.50	81	0.051	0.226	14.01	99	96
210	31.465	31.173	0.15	0.15	1.41	76	7.96	1.84	78	1.40	81	0.050	0.224	13.91	97	97
220	32.968	32.676	0.15	0.15	1.36	76	8.13	1.85	78	1.40	79	0.051	0.226	13.98	96	96
230	34.439	34.180	0.15	0.15	1.34	76	8.56	1.86	78	1.60	79	0.052	0.227	14.07	93	96
240	35.913	35.686	0.15	0.15	1.36	75	9.15	1.85	77	1.70	79	0.050	0.224	13.84	95	98
250	37.449	37.190	0.15	0.15	3.32	75	2.18	1.85	77	1.40	79	0.049	0.221	13.70	100	98
260	38.989	38.695	0.15	0.15	1.39	75	0.77	1.85	77	1.40	78	0.052	0.227	14.06	98	96
270	40.490	40.195	0.15	0.15	1.38	75	0.78	1.85	77	1.70	78	0.052	0.227	14.06	95	96
280	41.992	41.693	0.15	0.15	1.39	75	0.77	1.83	77	1.80	78	0.050	0.223	13.78	97	97
290	43.495	43.185	0.15	0.15	1.38	75	0.82	1.82	77	1.80	78	0.050	0.224	13.87	97	96

Run:	1 (Med) Particulate Sampling Data															
Elapsed Time (min)	Gas Meter 1 (ft <sup>3</sup> )	Gas Meter 2 (ft <sup>3</sup> )	Sample Rate 1 (cfm)	Sample Rate 2 (cfm)	Orifice dH 1 (H <sub>2</sub> O)	Meter Temp 1 (°F)	Meter Vacuum 1 (Hg)	Orifice dH 2 (H <sub>2</sub> O)	Meter Temp 2 (°F)	Meter Vacuum 2 (Hg)	Dilution Tunnel (°F)	Tunnel Center dP	sqrt dp	vsj	Pro. Rate 1	Pro. Rate 2
300	44.998	44.671	0.15	0.15	1.39	75	0.80	1.82	77	1.50	78	0.052	0.227	14.06	95	95
310	46.502	46.150	0.15	0.15	1.39	75	0.81	1.77	77	1.50	78	0.052	0.227	14.06	95	94
320	48.005	47.622	0.15	0.15	1.39	75	0.80	1.75	77	1.50	78	0.049	0.222	13.74	98	96
330	49.510	49.097	0.15	0.15	1.39	75	0.81	1.76	76	2.00	78	0.050	0.223	13.78	97	96
340	51.015	50.563	0.15	0.15	1.38	75	0.82	1.76	76	1.50	78	0.052	0.228	14.10	95	93
350	52.519	52.036	0.15	0.15	1.39	75	0.78	1.84	76	1.70	78	0.050	0.223	13.78	97	96
360	54.023	53.528	0.15	0.15	1.38	75	0.78	1.82	76	1.70	78	0.050	0.223	13.78	97	97
370	55.527	55.005	0.15	0.15	1.38	75	0.80	1.77	76	2.00	78	0.052	0.228	14.10	95	94
380	57.030	56.469	0.15	0.15	1.38	75	0.81	1.74	76	2.10	78	0.050	0.223	13.78	97	95
390	58.534	57.928	0.15	0.15	1.39	75	0.80	1.89	76	2.10	78	0.049	0.222	13.74	98	95
400	60.038	59.439	0.15	0.15	1.39	75	0.81	1.84	76	2.20	78	0.053	0.231	14.28	94	95
410	61.539	60.936	0.15	0.15	1.39	75	0.80	1.81	76	2.20	78	0.048	0.220	13.60	98	99
420	63.041	62.418	0.15	0.15	1.38	75	0.82	1.78	76	2.30	78	0.053	0.230	14.24	94	93
430	64.544	63.895	0.15	0.15	1.38	75	0.78	1.78	76	2.20	78	0.049	0.222	13.74	98	96
440	66.046	65.378	0.15	0.15	1.38	75	0.80	1.86	76	2.40	78	0.049	0.222	13.74	97	97
450	67.547	66.877	0.15	0.15	1.38	75	0.77	1.81	76	2.30	78	0.053	0.231	14.28	94	94
460	69.048	68.362	0.15	0.15	1.38	75	0.77	1.80	76	2.50	78	0.049	0.221	13.69	98	97
470	70.549	69.839	0.15	0.15	1.39	75	0.79	1.83	76	2.40	78	0.050	0.224	13.87	96	95
480	72.051	71.330	0.15	0.15	1.37	75	0.81	1.80	76	2.30	78	0.054	0.232	14.33	93	93
490	73.551	72.810	0.15	0.15	1.38	75	0.82	1.79	76	2.30	78	0.048	0.218	13.50	99	98
500	75.052	74.324	0.15	0.15	1.38	75	0.83	1.87	76	2.80	79	0.052	0.228	14.12	95	96
510	76.551	75.826	0.15	0.15	1.38	75	0.77	1.84	76	2.40	78	0.051	0.227	14.01	95	96
520	78.051	77.318	0.15	0.15	1.38	75	0.77	1.81	76	2.70	78	0.050	0.224	13.83	97	97
530	79.547	78.799	0.15	0.15	1.37	75	0.80	1.79	76	2.40	79	0.047	0.218	13.47	99	99
540	81.044	80.278	0.15	0.15	1.39	75	0.77	1.83	76	2.80	79	0.049	0.222	13.75	97	97
550	82.541	81.765	0.15	0.15	1.37	75	0.83	1.82	77	2.70	80	0.049	0.221	13.72	98	97
560	84.038	83.240	0.15	0.15	1.38	75	0.83	1.79	77	2.60	80	0.049	0.221	13.72	98	97
570	85.536	84.714	0.15	0.15	1.38	75	0.81	1.86	77	2.60	80	0.051	0.226	13.99	96	95
580	87.033	86.221	0.15	0.15	1.37	75	0.78	1.86	77	2.60	80	0.051	0.227	14.04	95	96
590	88.531	87.718	0.15	0.15	1.38	75	0.80	1.82	77	2.70	80	0.051	0.226	13.99	96	96
600	90.029	89.208	0.15	0.15	1.37	75	0.81	1.82	77	3.00	80	0.051	0.227	14.04	95	95
610	91.526	90.689	0.15	0.15	1.38	75	0.79	1.80	77	3.10	80	0.051	0.226	13.99	96	95
620	93.025	92.168	0.15	0.15	1.38	75	0.79	1.86	77	3.20	80	0.052	0.228	14.13	95	94
630	94.523	93.670	0.15	0.15	1.38	76	0.83	1.83	77	3.20	80	0.051	0.225	13.95	96	97
640	96.020	95.169	0.15	0.15	1.39	76	0.82	1.84	77	3.10	80	0.052	0.229	14.17	94	95
650	97.518	96.661	0.15	0.15	1.38	76	0.79	1.83	77	2.80	80	0.051	0.226	13.99	96	96
660	99.017	98.148	0.15	0.15	1.38	76	0.79	1.80	78	3.10	80	0.052	0.229	14.17	94	94
670	100.514	99.630	0.15	0.15	1.38	76	0.84	1.81	78	2.90	80	0.053	0.231	14.31	93	93
680	102.013	101.109	0.15	0.15	1.39	76	0.79	1.78	78	2.90	80	0.052	0.229	14.17	94	94
690	103.512	102.584	0.15	0.15	1.37	76	0.82	1.79	78	3.30	80	0.051	0.226	13.99	96	95

Run:	1 (Med) Particulate Sampling Data															
Elapsed Time (min)	Gas Meter 1 (ft <sup>3</sup> )	Gas Meter 2 (ft <sup>3</sup> )	Sample Rate 1 (cfm)	Sample Rate 2 (cfm)	Orifice dH 1 ("H <sub>2</sub> O)	Meter Temp 1 (° F)	Meter Vacuum 1 ("Hg)	Orifice dH 2 ("H <sub>2</sub> O)	Meter Temp 2 (° F)	Meter Vacuum 2 ("Hg)	Dilution Tunnel (° F)	Tunnel Center dP	sqrt dp	vsj	Pro. Rate 1	Pro. Rate 2
700	105.010	104.066	0.15	0.15	1.38	76	0.81	1.81	78	2.90	80	0.050	0.224	13.90	96	96
710	106.508	105.548	0.15	0.15	1.38	76	0.80	1.78	78	3.20	80	0.049	0.221	13.72	98	97
720	108.006	107.021	0.15	0.15	1.38	76	0.83	1.79	78	3.30	80	0.051	0.227	14.04	95	94
730	109.502	108.524	0.15	0.15	1.38	76	0.84	1.85	78	3.40	79	0.053	0.229	14.21	94	95
740	110.999	110.027	0.15	0.15	1.38	76	0.80	1.85	78	3.10	80	0.053	0.229	14.22	94	95
750	112.496	111.519	0.15	0.15	1.37	76	0.85	1.83	78	3.10	79	0.054	0.232	14.34	93	93
760	113.995	113.001	0.15	0.15	1.38	76	0.83	1.78	78	3.20	79	0.053	0.230	14.25	94	93
770	115.492	114.488	0.15	0.15	1.38	76	0.82	1.84	78	3.40	79	0.052	0.228	14.12	95	94
780	116.990	115.988	0.15	0.15	1.37	76	0.83	1.82	78	3.20	79	0.053	0.231	14.30	93	94
790	118.487	117.479	0.15	0.15	1.38	76	0.81	1.81	78	3.30	79	0.053	0.231	14.30	93	93
800	119.984	118.963	0.15	0.15	1.37	76	0.81	1.80	78	3.20	79	0.056	0.237	14.69	91	90
810	121.479	120.440	0.15	0.15	1.38	76	0.81	1.77	78	3.30	80	0.055	0.235	14.53	92	91
820	122.974	121.919	0.15	0.15	1.38	76	0.86	1.92	78	3.40	80	0.055	0.235	14.53	92	91
830	124.470	123.435	0.15	0.15	1.38	76	0.87	1.86	78	3.40	80	0.055	0.235	14.57	92	93
840	125.963	124.921	0.15	0.15	1.38	76	0.87	1.82	78	3.70	108	0.054	0.232	14.72	95	95
850	127.462	126.407	0.15	0.15	1.38	76	0.82	1.74	78	3.50	115	0.047	0.217	13.86	103	102
860	128.965	127.879	0.15	0.15	1.39	76	0.84	1.84	78	4.30	119	0.047	0.216	13.86	104	102
870	130.468	129.351	0.15	0.15	1.38	76	0.85	1.80	78	5.20	120	0.045	0.213	13.67	105	104
880	131.970	130.840	0.15	0.15	1.39	76	0.85	2.11	78	12.40	119	0.046	0.215	13.81	104	104
890	133.471	132.554	0.15	0.17	1.39	76	0.81	1.82	78	1.30	118	0.049	0.221	14.19	101	116
900	134.968	134.138	0.15	0.16	1.38	76	0.85	1.81	78	0.90	117	0.052	0.227	14.56	98	104
Avg/Tot	134.968	134.138	0.15	0.15	0.84	45	1.14	1.08	46	1.57	59	0.03	0.225		98	98

## ASTM E3053 / ASTM E2515 Emissions Results

Manufacturer: HHT Mt. Pleasant  
 Model: Pioneer III  
 Project No.: 0061WF102E  
 Tracking No.: N/A  
 Run: 2  
 Test Date: 01/31/19

Technician Signature: 

Integrated Test Run	
Particulate Emission Rate	<b>0.96 g/hr</b>
Total Particulate Emissions - E <sub>T</sub>	15.88 g
Emissions Factor	0.89 g/kg
CSA B415 Efficiency	<b>69.7% HHV</b>

First Hour Emissions	
Particulate Emission Rate	13.49 g/hr
Total Particulate Emissions - E <sub>T</sub>	13.49 g
Emissions Factor	1.68 g/kg

Burn Rate	<b>1.08 kg/hr dry</b>
Average Tunnel Temperature	97 degrees F
Avg. Velocity in Dilution Tunnel - v <sub>s</sub>	13.87 ft/second
Avg. Flow Rate in Dilution Tunnel - Q <sub>sd</sub>	8981.7 dscf/hour
Average Δp	0.053 inches H <sub>2</sub> O
Average ΔH	1.25 inches H <sub>2</sub> O
Total Time of Test	989 minutes



## ASTM E3053 / ASTM E2515 Emissions Results

Manufacturer: HHT Mt. Pleasant  
 Model: Pioneer III  
 Project No.: 0061WF102E  
 Tracking No.: N/A  
 Run: 2  
 Test Date: 01/31/19

Technician Signature: 

	1 <sup>st</sup> Hour	Sample Train 1	Sample Train 2	Sample	Unit
Total Sample Volume - $V_m$	8.763	141.530	141.296	N/A	ft <sup>3</sup>
Average Gas Meter Temperature	75.93	76.25	77.47		°F
Sample Volume (Std. Conditions) - $V_{mstd}$	8.323	134.338	135.190		dsf <sup>3</sup>
Total Particulates - $m_n$	12.5	15.7	13.2		mg
Particulate Concentration - $C_r/C_s$	1.502E-03	1.17E-04	9.76E-05		g/dsf <sup>3</sup>
Total Particulate Emissions - $E_T$	13.49	17.30	14.46		g
Particulate Emission Rate	13.49	1.05	0.88		g/hr
Emissions Factor	1.68	0.97	0.81		g/kg
Delta from Avg. Particulate Emissions		1.42	1.42		g

### Quality Checks

Filter Temps 80 - 90 °F	OK	Ambient Temp (55-90°F)	OK
Filter Face Velocity	OK	Negative Probe Weight	OK
Leakage Rate	OK	Pro-Rate Variation	CHECK 10 MIN.
		Dual Train Comparison	OK

## CSA B415.1 Results - Test Load

**Manufacturer:** HHT Mt. Pleasant      **Control #:** 0061WF102E  
**Model:** Pioneer III      **Test Duration:** 988  
**Date:** 01/31/19      **Output Category:** Low  
**Run:** 2

Test Results in Accordance with CSA B415.1-09

	HHV Basis	LHV Basis
Overall Efficiency	69.7%	74.9%
Combustion Efficiency	92.4%	92.4%
Heat Transfer Efficiency	75%	81.0%

	kJ/h	BTU/h
Output Rate	15,493	14,697
Input Rate	22,238	21,095

	kg/h	lb/h
Burn Rate	1.08	2.39

	dry kg	dry lb
Test Load Weight	17.72	39.05

MC wet (%)	18.30
MC dry (%)	22.40
Particulate (g )	135.19
CO (g)	1,931
Test Duration (h)	16.33

	g/MJ Output	g/kg Dry Fuel	g/h	lb/MM Btu Output
Particulate Emissions	0.53	7.63	8.28	1.24
CO Emissions	7.63	108.99	118.24	17.74
Air/Fuel Ratio (A/F)	12.51			

**VERSION**      **2-2**      **12/14/2009**      *Modified to fit this Format*

### ASTM E2780 Wood Heater Run Sheets

Client: HHT Project Number: 0061WF102E Run Number: 2  
 Model: Pioneer III Tracking Number: N/A Date: 1/31/2019  
 Test Crew: Aaron Kravitz  
 OMNI Equipment ID numbers: 132, 283A, 296-T32, 371, 372, 431, 559, 592, 635, 637

#### Wood Heater Run Notes

#### Air Control Settings

Primary:

Thermostat programed for longest possible off cycle

Secondary: Controlled w/

primary

Tertiary/Pilot: Fixed

Fan: Auto

#### Test Notes

Start up procedures & Timeline:

*High:*

Ignition: Torch, 60 s  
 Residual: 4.1 lb  
 Startup Fuel: 8 lb  
 Residual: 6.0 lb  
 Test Loading: Loaded by 1 min  
Door Closed at 1 min  
Air set at 1 min

*Med/Low:*

Coal Bed: 9.0 lb  
 Test Loading: Fuel loaded by 30 sec  
Door closed at 3:00  
Air set, boost on at 4:30

Time	Notes
38:00	Changed Filter A (T102AP)
39:00	Changed Filter B (T102BP)
60:00	Changed Filter A (T102AP-T103AP)

Technician Signature: 

Date: 2/4/19

### ASTM E2780 Wood Heater Run Sheets

Client: HHT Project Number: 0061WFI02E Run Number: 2  
 Model: Pioneer III Tracking Number: N/A Date: 1/31/2019  
 Test Crew: Aaron Kravitz  
 OMNI Equipment ID numbers: 132, 283A, 296-T32, 371, 372, 431, 559, 592, 635, 637

#### ASTM E2515 Sampling Information

Test Location: HHT Mt. Pleasant Clock Time @ ET=0: 7:17  
 Span Gas Concentrations: CO<sub>2</sub>(%): 15.05 CO(%): 5.093 CO(ppm): N/A

Test Run Validation Checks	Pre Test	Post Test
Zero Stack Gas Leakage	✓	✓
Zero Pitot Line Leakage	✓	✓
Zero Induced Draft	✓	
100% Smoke Capture	✓	

Test Run Validation Measurements	Pre Test		Post Test	
Scale Audit (lbs)	10.0		10.0	
CO <sub>2</sub> % (Zero/Span)	0.00	15.05	6.17	15.01
CO % (Zero/Span)	-0.001	5.093	0.010	5.072
CO ppm (Zero/Span)	N/A			
Sample A Leakage (cfm @"Hg)	∅		∅ @	-16
Sample B Leakage (cfm @"Hg)	∅		∅ @	-15
Room Air Velocity (ft/min)	250		250	
Barometric Pressure ("Hg)	29.6		29.5	
Relative Humidity (%)	52%		45%	
Tunnel Static ("H <sub>2</sub> O)	-0.2		-0.2	

#### Last Cleaning Dates

Flue Pipe	1/29/19
Dilution Tunnel	1/28/19
Sample Dryers	1/18/19

#### Dilution Tunnel Traverse

Traverse Point	1	2	3	4	5	6	7	8	Center
Δp ("H <sub>2</sub> O)	0.028	0.044	0.046	0.040	0.038	0.044	0.046	0.040	0.052
T (°F)	135	135	135	135	135	135	135	135	135

Technician Signature: 

Date: 2/4/19

# Wood Heater Test Data - ASTM E2515 - Proportion Rate Validation

Run: **2** (10 min)

Manufacturer: HHT Mt. Pleasant  
 Model: Pioneer III  
 Tracking No.: N/A  
 Project No.: 0061WF102E  
 Test Date: 31-Jan-19

Total Sampling Time: 989 min  
 Recording Interval: 10 min

Run:	2															
Particulate Sampling Data																
Elapsed Time (min)	Gas Meter 1 (ft <sup>3</sup> )	Gas Meter 2 (ft <sup>3</sup> )	Sample Rate 1 (cfm)	Sample Rate 2 (cfm)	Orifice dH 1 ("H <sub>2</sub> O)	Meter Temp 1 (°F)	Meter Vacuum 1 ("Hg)	Orifice dH 2 ("H <sub>2</sub> O)	Meter Temp 2 (°F)	Meter Vacuum 2 ("Hg)	Dilution Tunnel (°F)	Tunnel Center dP	sqrt dp	vsj	Pro. Rate 1	Pro. Rate 2
0	0.000	0.000			0.38	75	0.85	0.73	77	0.50	166	0.051	0.226	14.49		
10	1.437	1.419	0.14	0.14	1.22	75	5.41	1.79	77	4.70	194	0.053	0.230	15.09	110	108
20	2.892	2.871	0.15	0.15	1.27	75	5.57	1.67	77	4.90	204	0.055	0.235	15.49	110	109
30	4.320	4.320	0.14	0.14	1.25	75	10.47	1.76	77	10.30	175	0.053	0.230	14.87	107	109
40	5.760	5.730	0.14	0.14	1.31	76	0.85	3.05	77	1.50	186	0.053	0.230	15.00	109	107
50	7.207	7.188	0.14	0.15	1.26	76	0.91	1.67	78	1.10	168	0.054	0.232	14.93	107	108
60	8.763	8.629	0.16	0.14	1.30	76	0.92	1.67	78	0.90	183	0.053	0.230	14.97	117	109
70	10.260	10.080	0.15	0.15	1.26	76	0.85	1.69	78	1.40	170	0.055	0.235	15.09	110	106
80	11.680	11.503	0.14	0.14	1.23	76	0.98	1.68	78	0.90	184	0.054	0.232	15.12	106	106
90	13.114	12.932	0.14	0.14	1.28	76	0.97	1.70	78	1.30	175	0.056	0.237	15.29	105	104
100	14.553	14.366	0.14	0.14	1.28	76	0.84	1.72	78	1.30	165	0.056	0.237	15.17	104	104
110	15.994	15.803	0.14	0.14	1.28	76	0.87	1.70	78	1.30	158	0.055	0.235	14.95	105	104
120	17.432	17.238	0.14	0.14	1.28	76	0.99	1.70	78	1.10	151	0.050	0.224	14.17	109	109
130	18.868	18.669	0.14	0.14	1.27	76	0.84	1.70	78	1.30	151	0.049	0.221	14.03	110	109
140	20.299	20.098	0.14	0.14	1.27	76	0.84	1.69	78	0.90	140	0.049	0.221	13.90	108	108
150	21.730	21.527	0.14	0.14	1.27	76	1.00	1.67	78	1.40	119	0.049	0.221	13.66	107	106
160	23.168	22.956	0.14	0.14	1.28	76	0.86	1.69	78	1.30	113	0.051	0.226	13.86	104	104
170	24.608	24.381	0.14	0.14	1.28	76	0.89	1.68	78	0.90	113	0.050	0.224	13.72	106	104
180	26.047	25.803	0.14	0.14	1.27	76	0.88	1.66	78	0.90	111	0.053	0.230	14.10	102	101
190	27.484	27.223	0.14	0.14	1.23	76	0.82	1.66	78	0.90	112	0.052	0.228	13.98	103	102
200	28.898	28.640	0.14	0.14	1.26	76	0.93	1.69	78	0.90	119	0.049	0.221	13.66	105	105
210	30.326	30.069	0.14	0.14	1.25	76	0.91	1.68	78	0.90	110	0.049	0.221	13.55	105	106
220	31.753	31.496	0.14	0.14	1.25	76	0.99	1.69	78	1.40	104	0.050	0.224	13.61	104	104
230	33.181	32.924	0.14	0.14	1.26	76	0.88	1.68	78	1.00	95	0.052	0.228	13.77	101	101
240	34.632	34.389	0.15	0.15	1.26	76	0.86	1.68	78	1.30	87	0.052	0.228	13.67	102	103
250	36.085	35.856	0.15	0.15	1.26	76	0.90	1.68	78	1.10	85	0.053	0.230	13.78	101	102
260	37.539	37.325	0.15	0.15	1.25	76	0.84	1.70	78	1.00	84	0.053	0.230	13.77	101	102
270	38.991	38.792	0.15	0.15	1.26	76	0.88	1.68	78	0.90	84	0.053	0.230	13.77	101	102
280	40.443	40.260	0.15	0.15	1.26	76	0.84	1.69	77	1.40	84	0.053	0.230	13.77	101	102
290	41.890	41.722	0.14	0.15	1.25	76	0.87	1.68	77	1.30	83	0.055	0.235	14.01	98	100

Run:	2															
Elapsed Time (min)	Particulate Sampling Data															
	Gas Meter 1 (ft <sup>3</sup> )	Gas Meter 2 (ft <sup>3</sup> )	Sample Rate 1 (cfm)	Sample Rate 2 (cfm)	Orifice dH 1 (H <sub>2</sub> O)	Meter Temp 1 (°F)	Meter Vacuum 1 (Hg)	Orifice dH 2 (H <sub>2</sub> O)	Meter Temp 2 (°F)	Meter Vacuum 2 (Hg)	Dilution Tunnel (°F)	Tunnel Center dP	sqrt dp	vsj	Pro. Rate 1	Pro. Rate 2
300	43.338	43.185	0.14	0.15	1.24	76	0.84	1.66	77	1.40	83	0.053	0.230	13.75	100	102
310	44.764	44.610	0.14	0.14	1.24	76	0.86	1.67	77	1.20	82	0.053	0.230	13.74	99	99
320	46.187	46.031	0.14	0.14	1.24	76	0.99	1.65	77	1.20	82	0.054	0.232	13.87	98	98
330	47.607	47.448	0.14	0.14	1.24	76	0.84	1.66	77	1.00	82	0.052	0.228	13.61	99	99
340	49.025	48.863	0.14	0.14	1.23	76	0.85	1.63	77	1.00	81	0.053	0.230	13.73	98	98
350	50.454	50.295	0.14	0.14	1.24	76	0.87	1.70	77	0.90	80	0.053	0.230	13.72	99	99
360	51.872	51.726	0.14	0.14	1.23	76	0.96	1.66	77	1.00	81	0.054	0.232	13.86	97	98
370	53.287	53.152	0.14	0.14	1.23	76	0.92	1.65	77	1.40	80	0.053	0.230	13.72	98	99
380	54.698	54.574	0.14	0.14	1.22	76	1.00	1.67	77	1.00	81	0.054	0.232	13.86	97	98
390	56.119	55.998	0.14	0.14	1.26	76	0.96	1.70	77	1.00	80	0.053	0.230	13.72	98	99
400	57.552	57.430	0.14	0.14	1.26	76	0.90	1.68	77	1.00	80	0.054	0.232	13.84	98	98
410	58.983	58.858	0.14	0.14	1.25	76	0.98	1.68	77	1.30	80	0.053	0.230	13.72	99	99
420	60.412	60.284	0.14	0.14	1.25	76	1.01	1.67	77	1.10	79	0.053	0.230	13.70	99	99
430	61.839	61.707	0.14	0.14	1.24	76	1.03	1.66	77	1.00	80	0.053	0.230	13.72	99	99
440	63.264	63.127	0.14	0.14	1.25	76	0.95	1.64	77	1.30	79	0.052	0.228	13.57	99	99
450	64.688	64.544	0.14	0.14	1.24	76	1.02	1.65	77	1.40	80	0.053	0.230	13.72	98	98
460	66.109	65.959	0.14	0.14	1.24	76	1.06	1.65	77	1.40	80	0.052	0.228	13.59	99	99
470	67.529	67.372	0.14	0.14	1.24	76	0.93	1.65	77	1.50	79	0.053	0.230	13.70	98	98
480	68.962	68.806	0.14	0.14	1.26	76	0.98	1.68	77	1.30	79	0.053	0.230	13.70	99	99
490	70.399	70.243	0.14	0.14	1.26	76	1.09	1.70	77	1.00	78	0.053	0.230	13.69	99	99
500	71.833	71.679	0.14	0.14	1.25	76	1.07	1.70	77	1.20	79	0.053	0.230	13.70	99	99
510	73.266	73.113	0.14	0.14	1.25	76	1.04	1.67	77	1.00	79	0.053	0.230	13.70	99	99
520	74.698	74.545	0.14	0.14	1.26	76	0.98	1.69	77	1.50	78	0.054	0.232	13.82	98	98
530	76.127	75.975	0.14	0.14	1.26	76	1.09	1.66	77	1.20	79	0.053	0.230	13.70	99	99
540	77.555	77.403	0.14	0.14	1.25	76	0.98	1.69	77	1.20	79	0.053	0.230	13.70	99	99
550	78.982	78.830	0.14	0.14	1.24	76	1.01	1.67	77	1.50	79	0.053	0.230	13.70	99	99
560	80.407	80.255	0.14	0.14	1.25	76	1.10	1.66	77	1.00	80	0.052	0.228	13.59	99	100
570	81.832	81.679	0.14	0.14	1.23	76	1.10	1.67	77	1.20	79	0.053	0.230	13.70	98	99
580	83.255	83.103	0.14	0.14	1.23	76	0.96	1.66	77	1.50	80	0.053	0.230	13.72	98	99
590	84.676	84.524	0.14	0.14	1.23	76	0.95	1.67	77	1.20	79	0.052	0.228	13.57	99	99
600	86.098	85.944	0.14	0.14	1.23	76	1.08	1.67	77	1.10	80	0.052	0.228	13.59	99	99
610	87.517	87.363	0.14	0.14	1.23	76	0.99	1.67	77	1.30	79	0.053	0.230	13.70	98	98
620	88.937	88.781	0.14	0.14	1.23	76	0.96	1.66	77	1.20	80	0.052	0.228	13.59	99	99
630	90.357	90.199	0.14	0.14	1.23	76	1.05	1.66	77	1.10	79	0.054	0.232	13.83	97	97
640	91.776	91.616	0.14	0.14	1.23	76	1.11	1.65	77	1.40	79	0.053	0.230	13.70	98	98
650	93.194	93.032	0.14	0.14	1.22	76	1.12	1.62	77	1.30	79	0.053	0.230	13.70	98	98
660	94.612	94.448	0.14	0.14	1.26	76	0.99	1.67	77	1.50	79	0.052	0.228	13.57	99	99
670	96.045	95.879	0.14	0.14	1.25	76	1.12	1.69	77	1.10	79	0.052	0.228	13.57	100	100
680	97.477	97.308	0.14	0.14	1.25	76	0.98	1.67	77	1.10	78	0.053	0.230	13.69	99	99
690	98.908	98.736	0.14	0.14	1.25	76	1.01	1.68	77	1.30	79	0.053	0.230	13.70	99	99

Run:	2															
Elapsed Time (min)	Particulate Sampling Data															
	Gas Meter 1 (ft <sup>3</sup> )	Gas Meter 2 (ft <sup>3</sup> )	Sample Rate 1 (cfm)	Sample Rate 2 (cfm)	Orifice dH 1 ("H <sub>2</sub> O)	Meter Temp 1 (° F)	Meter Vacuum 1 ("Hg)	Orifice dH 2 ("H <sub>2</sub> O)	Meter Temp 2 (° F)	Meter Vacuum 2 ("Hg)	Dilution Tunnel (° F)	Tunnel Center dP	sqrt dp	vsj	Pro. Rate 1	Pro. Rate 2
700	100.338	100.163	0.14	0.14	1.25	76	0.99	1.67	77	1.50	79	0.053	0.230	13.70	99	99
710	101.768	101.589	0.14	0.14	1.24	77	1.07	1.66	77	1.40	78	0.052	0.228	13.56	99	100
720	103.195	103.014	0.14	0.14	1.24	77	1.10	1.66	77	1.40	79	0.052	0.228	13.57	99	100
730	104.622	104.439	0.14	0.14	1.25	77	1.16	1.66	77	1.20	79	0.052	0.228	13.57	99	100
740	106.048	105.862	0.14	0.14	1.22	77	1.11	1.67	77	1.60	78	0.051	0.226	13.43	100	100
750	107.473	107.283	0.14	0.14	1.24	77	1.16	1.67	77	1.50	79	0.052	0.228	13.57	99	99
760	108.897	108.705	0.14	0.14	1.24	77	1.03	1.66	78	1.60	79	0.052	0.228	13.57	99	99
770	110.322	110.126	0.14	0.14	1.23	77	1.15	1.66	78	1.10	78	0.052	0.228	13.56	99	99
780	111.744	111.545	0.14	0.14	1.23	77	1.08	1.66	78	1.10	79	0.051	0.226	13.44	100	100
790	113.166	112.964	0.14	0.14	1.23	77	1.15	1.68	78	1.30	79	0.053	0.230	13.70	98	98
800	114.592	114.394	0.14	0.14	1.24	77	1.01	1.66	78	1.20	79	0.051	0.226	13.44	100	101
810	116.021	115.823	0.14	0.14	1.25	77	1.09	1.68	78	1.50	78	0.052	0.228	13.56	99	100
820	117.451	117.251	0.14	0.14	1.24	77	1.01	1.66	78	1.50	78	0.052	0.228	13.56	99	99
830	118.880	118.680	0.14	0.14	1.24	77	1.03	1.65	78	1.20	78	0.052	0.228	13.56	99	100
840	120.307	120.106	0.14	0.14	1.24	77	1.12	1.68	78	1.40	78	0.052	0.228	13.56	99	99
850	121.733	121.531	0.14	0.14	1.24	77	1.13	1.66	78	1.50	78	0.053	0.230	13.69	98	98
860	123.159	122.956	0.14	0.14	1.23	77	1.15	1.64	78	1.30	78	0.051	0.226	13.43	100	100
870	124.585	124.380	0.14	0.14	1.24	77	1.03	1.67	78	1.20	78	0.051	0.226	13.43	100	100
880	126.009	125.803	0.14	0.14	1.23	77	1.02	1.67	78	1.60	79	0.053	0.230	13.70	98	98
890	127.433	127.224	0.14	0.14	1.23	77	1.13	1.67	78	1.60	78	0.052	0.228	13.56	99	99
900	128.856	128.646	0.14	0.14	1.23	77	1.01	1.66	78	1.20	78	0.052	0.228	13.56	99	99
910	130.279	130.066	0.14	0.14	1.23	77	1.14	1.65	78	1.30	78	0.052	0.228	13.56	99	99
920	131.701	131.485	0.14	0.14	1.24	77	1.13	1.66	78	1.30	78	0.052	0.228	13.56	99	99
930	133.122	132.904	0.14	0.14	1.23	77	1.13	1.66	78	1.60	78	0.052	0.228	13.56	99	99
940	134.543	134.322	0.14	0.14	1.23	77	1.16	1.65	78	1.60	78	0.052	0.228	13.56	99	99
950	135.963	135.740	0.14	0.14	1.23	77	1.02	1.66	78	1.30	78	0.052	0.228	13.56	99	99
960	137.384	137.158	0.14	0.14	1.27	77	1.13	1.72	78	1.20	86	0.053	0.230	13.79	99	99
970	138.820	138.590	0.14	0.14	1.24	77	1.17	1.65	78	1.40	97	0.052	0.228	13.80	102	102
980	140.242	140.010	0.14	0.14	1.23	77	1.07	1.63	78	1.30	106	0.051	0.226	13.77	102	102
Avg/Tot	140.242	140.010	0.14	0.14	1.24	76	1.18	1.68	77	1.40	97	0.05	0.229		101	101

## **2.3 - Sample Analysis & Tares**

Analysis Worksheets  
Tared Filter, Probe, and O-Ring Data

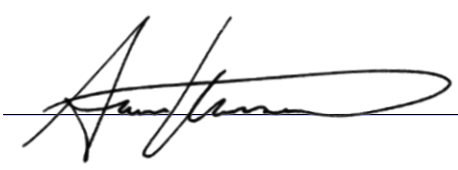

## Wood Heater Lab Data - ASTM E2515

Manufacturer: HHT Mt. Pleasant      Equipment Numbers: 283A, 592, 637  
 Model: Pioneer III  
 Tracking No.: N/A  
 Project No.: 0061WF102E  
 Run #: 1 High      Technician Signature:   
 Date: 1/29/19

### TRAIN 1 (First Hour emissions)

Sample Component	Reagent	Filter, Probe or Seal #	Mass Readings		
			Tare, mg	Final, mg	Particulate, mg
A. Front filter catch	Filter	T80S	85.3	92.1	6.8
B. Rear filter catch	Filter	T81S	85.3	88.0	2.7
C. Probe catch*	Probe				0.0
D. Filter seals catch*	Seals				0.0
1 <sup>st</sup> hour Sub-Total, mg:					9.5

### TRAIN 1 (Remainder of Test)

Sample Component	Reagent	Filter, Probe or Seal #	Mass Readings		
			Tare, mg	Final, mg	Particulate, mg
A. Front filter catch	Filter	T75AP	184.1	181.5	-2.6
B. Rear filter catch	Filter				0.0
C. Probe catch*	Probe	2	115014.6	115016.2	1.6
D. Filter seals catch*	Seals	R721	3344.2	3349.9	5.7
Remainder Sub-Total, mg:					4.7
Train 1 Aggregate, mg:					14.2

### TRAIN 2

Sample Component	Reagent	Filter, Probe or Seal #	Mass Readings		
			Tare, mg	Final, mg	Particulate, mg
A. Front filter catch	Filter	T75BP	176.8	181.4	4.6
B. Rear filter catch	Filter	T82S, T83S	170.3	176.4	6.1
C. Probe catch*	Probe	3.0	116009.4	116010.8	1.4
D. Filter seals catch*	Seals	R722	3335.3	3337.8	2.5
Train 2 Aggregate, mg:					14.6

### AMBIENT

Sample Component	Reagent	Filter, Probe or Seal #	Mass Readings		
			Tare, mg	Final, mg	Particulate, mg
A. Front filter catch*	Filter				0.0
Ambient Aggregate, mg:					0.0

\*Particulate catch that results in a negative number, is assumed to be zero for probes and seals, negative numbers for filters are assumed to be included in O-ring seal weights.

### ASTM E2780 Wood Heater Run Sheets

Client: **HHT** Project Number: **0061WF102E** Run Number: **I High**  
 Model: **Pioneer III** Tracking Number: **N/A** Date: **1/29/2019**  
 Test Crew: **Aaron Kravitz**  
 OMNI Equipment ID numbers: **132, 283A, 296-T32, 371, 372, 431, 559, 592, 635, 637**

#### ASTM E2515 Lab Sheet

Assembled By:

*A. Kravitz*

Date/Time in Desiccator:

*2/4/19*

Weighing #1	Weighing #2	Weighing #3	Weighing #4
Date/Time: <i>2/8/18</i>	Date: <i>2/12/19</i>	Date: <i>2/15/19</i>	Date:
R/H %: <i>14.1</i>	R/H %: <i>12.1</i>	R/H %: <i>14.7</i>	R/H %:
Temp (F): <i>71.2</i>	Temp (F): <i>70.8</i>	Temp (F): <i>70.7</i>	Temp (F):
Audit 1: <i>199.9</i>	Audit 1: <i>199.9</i>	Audit 1: <i>2000.2</i>	Audit 1:
Audit 2: <i>2000.2</i>	Audit 2: <i>2000.1</i>	Audit 2: <i>99997.7</i>	Audit 2:
Audit 3: <i>99995.0</i>	Audit 3: <i>99997.7</i>	Audit 3: <i>-</i>	Audit 3:
Initials: <i>AK</i>	Initials: <i>AK</i>	Initials: <i>AK</i>	Initials:

Train	Item	ID #	Tare (mg)	Weight (mg)	Weight (mg)	Weight (mg)	Weight (mg)
A	Filter (60 min)	T80S	85.3	<i>92.2</i>	<i>92.7</i>	-	
		T81S	85.3	<i>88.1</i>	<i>88.0</i>	-	
A	Front Filter (Remainder)	T75AP	184.1	<i>181.4</i>	<i>181.5</i>	-	
A	Probe	2	115014.6	<i>115016.0</i>	<i>115016.3</i>	<i>115016.2</i>	
A	O-Ring Set	R721	3344.2	<i>3350.1</i>	<i>3349.9</i>	-	
B	Filter	T75BP	176.8	<i>181.4</i>	<i>181.4</i>	-	
		T82S	85.3	<i>176.5</i>	<i>176.4</i>	-	
		T83S	85.0				
B	Probe	3	116009.4	<i>116010.7</i>	<i>116010.8</i>	-	
B	O-Ring Set	R722	3335.3	<i>3338.0</i>	<i>3337.8</i>	-	

Technician Signature: \_\_\_\_\_

*AK*

Date: \_\_\_\_\_

*2/15/19*

## Wood Heater Lab Data - ASTM E2515

Manufacturer: HHT Mt. Pleasant      Equipment Numbers: 283A, 592, 637

Model: Pioneer III

Tracking No.: N/A

Project No.: 0061WF102E

Run #: 1 (Med)

Date: 1/29/19

Technician Signature: \_\_\_\_\_

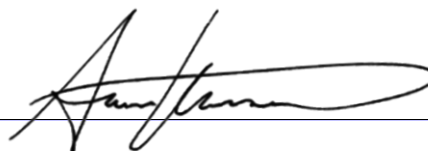

### TRAIN 1 (First Hour emissions)

Sample Component	Reagent	Filter, Probe or Seal #	Mass Readings		
			Tare, mg	Final, mg	Particulate, mg
A. Front filter catch	Filter	T84S	85.8	100.0	14.2
B. Rear filter catch	Filter	T85S	85.7	87.0	1.3
C. Probe catch*	Probe				0.0
D. Filter seals catch*	Seals				0.0
1 <sup>st</sup> hour Sub-Total, mg:					15.5

### TRAIN 1 (Remainder of Test)

Sample Component	Reagent	Filter, Probe or Seal #	Mass Readings		
			Tare, mg	Final, mg	Particulate, mg
A. Front filter catch	Filter	T101AP	170.5	175.0	4.5
B. Rear filter catch	Filter	T108	85.0	85.9	0.9
C. Probe catch*	Probe	OES 3	114768.0	114770.0	2.0
D. Filter seals catch*	Seals	R723	3356.2	3357.4	1.2
Remainder Sub-Total, mg:					8.6
Train 1 Aggregate, mg:					24.1

### TRAIN 2

Sample Component	Reagent	Filter, Probe or Seal #	Mass Readings		
			Tare, mg	Final, mg	Particulate, mg
A. Front filter catch	Filter	T101BP	171.9	184.2	12.3
B. Rear filter catch	Filter	T106/07/09	254.5	259.8	5.3
C. Probe catch*	Probe	OES 4	114145.1	114147.4	2.3
D. Filter seals catch*	Seals	R724	4095.7	4099.6	3.9
Train 2 Aggregate, mg:					23.8

### AMBIENT

Sample Component	Reagent	Filter, Probe or Seal #	Mass Readings		
			Tare, mg	Final, mg	Particulate, mg
A. Front filter catch*	Filter				0.0
Ambient Aggregate, mg:					0.0

\*Particulate catch that results in a negative number, is assumed to be zero for probes and seals, negative numbers for filters are assumed to be included in O-ring seal weights.

### ASTM E2780 Wood Heater Run Sheets

Client: HHT Project Number: 0061WF102E Run Number: I Medium  
 Model: Pioneer III Tracking Number: N/A Date: 1/31/2019  
 Test Crew: Aaron Kravitz  
 OMNI Equipment ID numbers: 132, 283A, 296-T32, 371, 372, 431, 559, 592, 635, 637

#### ASTM E2515 Lab Sheet

Assembled By:

*A. Kravitz*

Date/Time in Desiccator:

*2/4/19*

Weighing #1	Weighing #2	Weighing #3	Weighing #4
Date/Time: <i>2/8/19</i>	Date: <i>2/12/19</i>	Date: <i>2/15/19</i>	Date:
R/H %: <i>14.1</i>	R/H %: <i>12.1</i>	R/H %:	R/H %:
Temp (F): <i>71.2</i>	Temp (F): <i>70.8</i>	Temp (F):	Temp (F):
Audit 1: <i>122.9</i>	Audit 1: <i>122.9</i>	Audit 1:	Audit 1:
Audit 2: <i>2000.2</i>	Audit 2: <i>2000.1</i>	Audit 2:	Audit 2:
Audit 3: <i>22228.0</i>	Audit 3: <i>22227.7</i>	Audit 3:	Audit 3:
Initials: <i>A</i>	Initials: <i>A</i>	Initials:	Initials:

Train	Item	ID #	Tare (mg)	Weight (mg)	Weight (mg)	Weight (mg)	Weight (mg)
A	Filter (60 min)	T84S	85.8	<i>100.1</i>	<i>100.0</i>		
		T85S	85.7	<i>87.2</i>	<i>87.0</i>		
A	Front Filter (Remainder)	T101AP	170.5	<i>174.8</i>	<i>175.0</i>		
		T108	85.0	<i>86.0</i>	<del><i>86.0</i></del> <i>85.9</i>		
A	Probe	OES 3	114768.0	<i>114770.2</i>	<i>114770.0</i>		
A	O-Ring Set	R723	3356.2	<i>3357.5</i>	<i>3357.4</i>		
B	Filter	T101BP	171.9	<i>184.1</i>	<i>184.2</i>		
		T106	85.2	<i>259.9</i>	<i>259.8</i>		
		T107	84.7	<i>↗</i>			
		T109	84.6	<i>↗</i>			
B	Probe	OES 4	114145.1	<i>114147.2</i>	<i>114147.4</i>		
B	O-Ring Set	R724	4095.7	<i>4099.7</i>	<i>4099.6</i>		

Technician Signature: \_\_\_\_\_

*[Handwritten Signature]*

Date: \_\_\_\_\_

*2/15/19*

## Wood Heater Lab Data - ASTM E2515

Manufacturer: HHT Mt. Pleasant  
 Model: Pioneer III  
 Tracking No.: N/A  
 Project No.: 0061WF102E  
 Run #: 2  
 Date: 1/31/19

Equipment Numbers: 283A, 592, 637

Technician Signature: \_\_\_\_\_

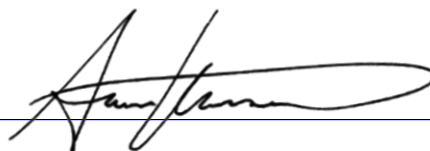

### TRAIN 1 (First Hour emissions)

Sample Component	Reagent	Filter, Probe or Seal #	Mass Readings		
			Tare, mg	Final, mg	Particulate, mg
A. Front filter catch	Filter	T102AP	171.4	183.9	12.5
B. Rear filter catch	Filter				0.0
C. Probe catch*	Probe				0.0
D. Filter seals catch*	Seals				0.0
1 <sup>st</sup> hour Sub-Total, mg:					12.5

### TRAIN 1 (Remainder of Test)

Sample Component	Reagent	Filter, Probe or Seal #	Mass Readings		
			Tare, mg	Final, mg	Particulate, mg
A. Front filter catch	Filter	T103AP	172.0	172.2	0.2
B. Rear filter catch	Filter				0.0
C. Probe catch*	Probe	7	114981.2	114981.0	0.0
D. Filter seals catch*	Seals	R725	3356.5	3359.5	3.0
Remainder Sub-Total, mg:					3.2
Train 1 Aggregate, mg:					15.7

### TRAIN 2

Sample Component	Reagent	Filter, Probe or Seal #	Mass Readings		
			Tare, mg	Final, mg	Particulate, mg
A. Front filter catch	Filter	T102BP	170.8	179.0	8.2
B. Rear filter catch	Filter	T103BP	172.2	174.5	2.3
C. Probe catch*	Probe	8.0	115592.9	115593.4	0.5
D. Filter seals catch*	Seals	R726	3266.4	3268.6	2.2
Train 2 Aggregate, mg:					13.2

### AMBIENT

Sample Component	Reagent	Filter, Probe or Seal #	Mass Readings		
			Tare, mg	Final, mg	Particulate, mg
A. Front filter catch*	Filter				0.0
Ambient Aggregate, mg:					0.0

\*Particulate catch that results in a negative number, is assumed to be zero for probes and seals, negative numbers for filters are assumed to be included in O-ring seal weights.

### ASTM E2780 Wood Heater Run Sheets

Client: **HHT** Project Number: **0061WF102E** Run Number: **2**

Model: **Pioneer III** Tracking Number: **N/A** Date: **1/31/2019**

Test Crew: **Aaron Kravitz**

OMNI Equipment ID numbers: **132, 283A, 296-T32, 371, 372, 431, 559, 592, 635, 637**

#### ASTM E2515 Lab Sheet

Assembled By:

*A. Kravitz*

Date/Time in Desiccator:

*2/4/19*

Weighing #1	Weighing #2	Weighing #3	Weighing #4
Date/Time: <i>2/8/19</i>	Date: <i>2/12/19</i>	Date: <i>2/15/19</i>	Date:
R/H %: <i>14.1</i>	R/H %: <i>12.1</i>	R/H %: <i>14.7</i>	R/H %:
Temp (F): <i>71.2</i>	Temp (F): <i>70.8</i>	Temp (F): <i>70.7</i>	Temp (F):
Audit 1: <i>199.9</i>	Audit 1: <i>199.6</i>	Audit 1: <i>2000.2</i>	Audit 1:
Audit 2: <i>2000.2</i>	Audit 2: <i>2000.1</i>	Audit 2: <i>99997.7</i>	Audit 2:
Audit 3: <i>99998.0</i>	Audit 3: <i>99997.7</i>	Audit 3: <i>-</i>	Audit 3:
Initials: <i>A</i>	Initials: <i>A</i>	Initials: <i>A</i>	Initials:

Train	Item	ID #	Tare (mg)	Weight (mg)	Weight (mg)	Weight (mg)	Weight (mg)
A	Filter (60 min)	T102AP	171.4	<i>184.0</i>	<i>183.9</i>	-	
A	Front Filter (Remainder)	T103AP	172.0	<i>172.1</i>	<i>172.2</i>	-	
A	Probe	7	114981.2	<i>114981.2</i>	<i>114981.0</i>		
A	O-Ring Set	R725	3356.5	<i>3359.8</i>	<i>3359.5</i>	<i>3359.5</i>	
B	Filter	T102BP	170.8	<i>178.9</i>	<i>179.0</i>	-	
		T103BP	172.2	<i>174.4</i>	<i>174.5</i>	-	
B	Probe	8	115592.9	<i>115593.5</i>	<i>115593.7</i>	<i>115593.4</i>	
B	O-Ring Set	R726	3260.4	<i>3268.7</i>	<i>3268.9</i>	-	

Technician Signature: \_\_\_\_\_



Date: \_\_\_\_\_

*2/15/19*

Tare Sheet: (check one)

Probes \_\_\_\_\_

47mm Filters

100mm Filters \_\_\_\_\_

O-Ring Pair \_\_\_\_\_

Prepared By: B Davis

Balance ID #: Omni-00637

Thermohygrometer ID #: Omni-00592 Audit Weight ID #/Mass: Omni-00283A / 200 mg

Placed in Desiccator:	Date: <u>11/6/18</u> Time: <u>0945</u> RH %: <u>15.3</u> T (°F): <u>71.9</u> Audit: <u>200.1</u>	Date: <u>11/7/18</u> Time: <u>0925</u> RH %: <u>17.6</u> T (°F): <u>71.8</u> Audit: <u>200.1</u>	Date: _____ Time: _____ RH %: _____ T (°F): _____ Audit: _____	Date: _____ Time: _____ RH %: _____ T (°F): _____ Audit: _____	Date Used	Project Number	Run No.
ID #							
T71AP	183.2	183.1	/				
T71BP	183.1	183.0	/				
T72AP	178.4	178.3	/				
T72BP	179.1	179.0	/				
T73AP	182.2	182.2	/				
T73BP	180.7	180.7	/				
T74AP	179.4	179.2	/				
T74BP	183.1	183.2	/				
T75AP	184.3	184.1	/		1/22/19	0061WF102E	1H
T75BP	176.9	176.8	/		↓	↓	↓
T76S	85.2	85.1	/				
T77S	85.0	85.0	/				
T78S	84.7	84.8	/				
T79S	85.3	85.3	/				
T80S	85.2	85.3	/		1/29/19	0061WF102E	1H
T81S	85.3	85.3	/		↓	↓	↓
T82S	85.0	85.0	/				
T83S	85.7	85.5	/				
T84S	85.8	85.8	/				1M
T85S	85.7	85.7	/				↓
Initials: <u>BR</u>	Initials: <u>BR</u>	Initials: _____	Initials: _____				

Final Technician Signature: [Signature]  
Control No. P-SFDP-0002.xls, Effective date: 2/1/2017

Date: 11/15/18

Evaluator signature: [Signature]





Tare Sheet: (check one)

Probes

47mm Filters

100mm Filters

O-Ring Pair

Prepared By: B Davis

Balance ID #: omni-00637

Thermohyrometer ID #: omni-00592

Audit Weight ID #/Mass: omni-00283A / 100g

Placed in Dessicator:	Date: <u>1/23/19</u>	Date: <u>1/24/19</u>	Date: <u>1/24/19</u>	Date: <u>1/25/19</u>	Date Used	Project Number	Run No.
Date: <u>1/22/19</u>	Time: <u>0840</u>	Time: <u>0910</u>	Time: <u>1600</u>	Time: <u>0802</u>			
Time: <u>0800</u>	RH %: <u>18.6</u>	RH %: <u>19.7</u>	RH %: <u>-</u>	RH %: <u>17.4</u>			
ID #	T (°F): <u>76.7</u>	T (°F): <u>72.1</u>	T (°F): <u>-</u>	T (°F): <u>72.2</u>			
	Audit: <u>99997.9</u>	Audit: <u>99997.8</u>	Audit: <u>-</u>	Audit: <u>99997.8</u>			
2	115015.2	115014.8	115014.4	115014.6	1/29/19	0061WF102E	14
3	116010.1	116009.6	116009.4	-			↓
OES 3	114768.9	114768.2	114768.0	-			IM
OES 4	114145.6	114145.1	114145.1	-			↓
8	115593.8	115592.9	115592.9	-	1/30/19		26
7	114981.4	114981.2	-				↓
9	115692.1	115691.9	-				
11	114186.4	114185.7	114185.7	-			
12	114283.7	114283.5	-				
16	114266.5	114266.1	114266.1	-			
14	114548.7	114547.9	114548.3	114548.3	-		
20	114253.2	114253.0	-				
21	114391.9	114391.3	114391.3	-			
22	114343.7	114343.3	114343.1	-			
23	114076.7	114076.1	114075.0	-			
31	114367.3	114367.0	114366.6	114366.8	-		

Initials: BZ Initials: BZ Initials: AL Initials: BR

Final Technician Signature: \_\_\_\_\_

Date: 2/20/19

Evaluator signature: [Signature]

Control No. P-SFDP-0002.xls, Effective date: 2/1/2017





# **Section 3**

## **Laboratory Quality Assurance**

3.1 - Quality Assurance/Quality Control

3.2 - Calibration Data

3.3 - Example Calculations

### **3.1 - Quality Assurance/Quality Control**

*OMNI* follows the guidelines of ISO/IEC 17025, “General Requirements for the Competence of Testing and Calibration Laboratories,” and the quality assurance/quality control (QA/QC) procedures found in *OMNI*'s Quality Assurance Manual.

*OMNI*'s scope of accreditation includes, but is not limited to, the following:

- ANSI (American National Standards Institute) for certification of product to safety standards.
- To perform product safety testing by the International Accreditation Service, Inc. (formerly ICBO ES) under accreditation as a testing laboratory designated TL-130.
- To perform product safety testing as a “Certification Organization” by the Standards Council of Canada (SCC).
- Serving as a testing laboratory for the certification of wood heaters by the U.S. Environmental Protection Agency.

This report is issued within the scope of *OMNI*'s accreditation. Accreditation certificates are available upon request.

The manufacturing facilities and quality control system for the production of the Pioneer III at Hearth & Home Technologies, Inc. were evaluated to determine if sufficient to maintain conformance with *OMNI*'s requirements for product certification. *OMNI* has concluded that the manufacturing facilities, processes, and quality control system are adequate to produce the appliance congruous with the standards and model codes to which it was evaluated.

This report shall not be reproduced, except in full, without the written approval of *OMNI-Test Laboratories, Inc.*

### 3.2 - Calibration Data

Equipment for ASTM E2515, ASTM E2779, & EPA Method 28R

ID #	Lab Name/Purpose	Log Name	Attachment Type
132	10 lb Weight	Weight Standard, 10 lb.	Calibration Log
185	1000lb Scale	Weight Indicator, Model WI-127	Calibration Certificate
283A	Audit Weight Set	Troemer weight set	Calibration Certificate
371	Sample Box / Dry Gas Meter	Apex Automated Emissions Sampling Box	Calibration Log
372	Sample Box / Dry Gas Meter	Apex Automated Emissions Sampling Box	Calibration Log
410	Microtector	Dwyer Microtector	Calibration Certificate
559	Vaneometer	Dwyer Vaneometer	Equipment Record
592	Thermohygrometer	Omega Digital Thermohygrometer	Calibration Log
419	Combustion Gas Analyzer	CAI Gas Analyzer	See Run Sheet
637	Milligram Balance	Analytical Balance - Mettler - Toledo	Calibration Certificate
650	Barometer/Hygrometer	Digital Barometer	Calibration Certificate

## SCALE WEIGHT CALIBRATION DATA SHEET

Weight to be calibrated: 10 pounds

ID Number: OMNI-00132

Standard Calibration Weight: 10 pounds

ID Number: OMNI-00255

Scale Used: MTW-150K

ID Number: OMNI-00353

Date: 2/23/2018

By: B. Davis

Standard Weight (A) (Lb.)	Weight Verified (B) (Lb.)	Difference (A - B)	% Error
10.0	10.0	0.0	0

\*Acceptable tolerance is 1%.

*This calibration is traceable to NIST using calibrated standard weights.*

Technician signature:  Date: 2/23/18



# Certificate of Calibration



9109767

Certificate Page 1 of 1

## Instrument Identification

Company ID: 96243  
TRAVIS INDUSTRIES, INC.  
RUSS MCBRIEN  
12521 HARBOUR REACH DR  
MUKILTEO, WA 98275

PO Number: 69479

Instrument ID: 110850562  
Manufacturer: WEIGH-TRONIX  
Description: SCALE, 0 TO 1000 LBS X 0.1

Model Number: E1010  
Serial Number: 110850562

Accuracy:  $\pm 0.2$  lbs

## Certificate Information

Reason For Service: ON-SITE CALIBRATION  
Type of Cal: NORMAL  
As Found Condition: IN TOLERANCE  
As Left Condition: IN TOLERANCE  
Procedure: NA17-20MM-01, JUL 1996 SCALES

Technician: TOM COSGROVE  
Cal Date 15Sep2014  
Cal Due Date: 15Sep2015  
Interval: 12 MONTHS  
Temperature: 23.0 C  
Humidity: 42.0 %

Remarks: *Refer to attached datasheet, 1 page*

Tektronix certifies the performance of the above instrument has been verified using test equipment of known accuracy, which is traceable to National Metrology Institutes (NIST, NPL, PTB) that are linked to the International System of Units (SI). The policies and procedures used comply with ANSI/NCSL Z540.1-1994 (R2002).

This certificate shall not be reproduced, except in full, without the written permission of Tektronix.

Approved By: TOM COSGROVE  
Service Representative

Issue Date: 9/15/2014

## Calibration Standards

NIST Traceable#	Inst. ID#	Description	Manufacturer	Model	Cal Date	Date Due
8683326	47-0085	WEIGHT SET, CLASS F	AKO	TSD2078	24Apr2014	24Apr2017

1420 75th St. SW • Everett, WA 98203 • Phone: 425-355-3700 • Fax: 425-355-3900  
7661 South 180th Street • Kent, WA 98032 • Phone: 425-286-1085 • Fax: 425-286-1093





Manufacturer: Welgh-Tronix  
Model Number: E1010

Calibration Date: 9/15/2014

Serial Number: 110850562  
Asset Number: 110850562

Procedure: NA17-20MM-01  
Revision/Date: 07/01/1996

Function / Range	Nominal Value	As Found	Result	As Left	Result	Min	Max	Units
<b>Readout Accuracy</b>								
Platform Linearity	5.00	5.00	Pass	5.00	Pass	4.98	5.02	lb
Mass	100.00	100.00	Pass	100.00	Pass	99.80	100.20	lb
Mass	250.00	250.00	Pass	250.00	Pass	249.80	250.20	lb
Mass	500.00	499.90	Pass	499.90	Pass	499.80	500.20	lb
Mass	750.00	749.90	Pass	749.90	Pass	749.80	750.20	lb
Mass	1000.00	999.90	Pass	999.90	Pass	999.80	1000.20	lb

\*\*\*\*\*END OF MEASUREMENT REPORT\*\*\*\*\*



Calibration complies with ISO/IEC 17025, ANSI/NCSL Z540-1, and 9001



Cert. No.: 6530-9263396

Traceable® Certificate of Calibration for Digital Barometer

Manufactured for and distributed by : Control Company "Drawer 58307,Houston,TX,77258,USA"

Instrument Identification:

Model: 6530, S/N: 181062211 Manufacturer: Control Company

Standards/Equipment:

Table with 4 columns: Description, Serial Number, Due Date, NIST Traceable Reference. Rows include Digital Barometer, Digital Thermometer, Chilled Mirror Hygrometer, and Climate Chamber.

Certificate Information:

Technician: 57 Procedure: CAL-31 Cal Date: 26 Feb 2018 Cal Due Date: 26 Feb 2020
Test Conditions: 54.9%RH 22.83°C 1023mBar

Calibration Data: (New Instrument)

Table with 11 columns: Unit(s), Nominal, As Found, In Tol, Nominal, As Left, In Tol, Min, Max, ±U, TUR. Rows show calibration data for %RH, °C, and mb/hPa.

This certificate indicates Traceability to standards provided by (NIST) National Institute of Standards and Technology and/or a National Standards Laboratory.

A Test Uncertainty Ratio of at least 4:1 is maintained unless otherwise stated and is calculated using the expanded measurement uncertainty. Uncertainty evaluation includes the instrument under test and is calculated in accordance with the ISO "Guide to the Expression of Uncertainty in Measurement : (GUM). The uncertainty represents an expanded uncertainty using a coverage factor k=2 to approximate a 95% confidence level.

Nominal=Standard's Reading; As Left=Instrument's Reading; In Tol=In Tolerance; Min/Max=Acceptance Range; ± U=Expanded Measurement Uncertainty; TUR=Test Uncertainty Ratio; Accuracy=±(Max-Min)/2; Min=As Left Nominal(Rounded) - Tolerance; Max= As Left Nominal(Rounded) + Tolerance;

Nicol Rodriguez, Quality Manager

Aaron Justice, Technical Manager

Maintaining Accuracy:

In our opinion once calibrated your Digital Barometer should maintain its accuracy. There is no exact way to determine how long calibration will be maintained. Digital Barometer change little, if any at all, but can be affected by aging, temperature, shock, and contamination.

Recalibration:

For factory calibration and re-certification traceable to National Institute of Standards and Technology contact Control Company.

CONTROL COMPANY 12554 Galveston RD Suite B230 Webster TX USA 77598
Phone 281 482-1714 Fax 281 482-9448 sales@control3.com www.control3.com

Control Company is an ISO/IEC 17025:2005 Calibration Laboratory Accredited by (A2LA) American Association for Laboratory Accreditation, Certificate No. 1750.01.
Control Company is ISO 9001:2008 Quality Certified by DNV GL, Certificate No. CERT-01805-2006-AQ-HOU-RvA.
International Laboratory Accreditation Cooperation (ILAC) - Multilateral Recognition Arrangement (MRA).

# Certificate of Calibration



**JJ Calibrations, Inc.**

7007 SE Lake Rd  
Portland, OR 97267-2105  
Phone 503.786.3005  
FAX 503.786.2994

Certificate Number: **685888**

**Omni-Test Laboratories**  
13327 NE Airport Way  
Portland, OR 97230

PO: **180188**  
Order Date: **10/09/2018**  
Authorized By: **N/A**



Property #: **OMNI-00283A**  
User: **N/A**  
Department: **N/A**  
Make: **Troemner Inc**  
Model: **1mg-100g (Class F)**  
Serial #: **47883**  
Description: **Mass Set, 21pc**  
Procedure: **DCN 500901**  
Accuracy: **Class F**

Calibrated on: **10/26/2018**  
\*Recommended Due: **10/26/2023**  
Environment: **20 °C 57 % RH**  
\* As Received: **Within Tolerance**  
\* As Returned: **Within Tolerance**  
Action Taken: **Calibrated**  
Technician: **139**

Remarks: \* Many factors may cause the unit to drift out of calibration before the recommended due date. Any reported error is the absolute value between the reference and the unit. Uncertainties include the effects of the unit.

**This set meets Class F specifications.**  
**Received and returned eight (8) masses in a black case secured by a rubber band.**

### Standards Used

Std ID	Manufacturer	Model	Nomenclature	Due Date	Trace ID
723A	Rice Lake	1mg-200g (Class 0)	Mass Set,	03/23/2019	668240
800A	Sartorius	MSA225W100DI	Analytical Balance	12/11/2018	663857

### Measurement Data

Parameter	Measurement Description	Range Unit	Reference	Min	Max	*Error	UUT	Uncertainty
<b>Before/After</b>								Accredited = ✓
<b>Mass</b>								
Dot	200 mg		200.00030	199.4603	200.5403	0.0500	200.0503 mg	6.2E-01 ✓
	1 g		1.00000880	0.9991088	1.0009088	0.0000000	1.0000088 g	1E-03 ✓
	2 g		2.00001470	1.9989147	2.0011147	0.0003250	2.0003397 g	1.3E-03 ✓
	5 g		5.00000840	4.9985084	5.0015084	0.0000400	4.9999684 g	1.7E-03 ✓
	10 g		10.0000100	9.998010	10.002010	0.000245	9.999765 g	2.3E-03 ✓
Dot	20 g		20.0000140	19.996014	20.004014	0.000990	20.001004 g	4.6E-03 ✓
	50 g		49.9999660	49.989966	50.009966	0.000595	49.999371 g	1.1E-02 ✓
	100 g		100.000000	99.98000	100.02000	0.00194	99.99806 g	2.3E-02 ✓

JJ Calibrations, Inc. certifies that this instrument has been calibrated in accordance with the JJ Calibrations Quality Assurance Manual with the stated procedure using standards that are traceable to the National Institute of Standards and Technology (NIST), or other National Measurement Institutes (NMI's), or by using natural physical constants, intrinsic standards or ratio calibration techniques. The quality system and this certificate are in compliance with ANSI/NCCL Z540-1-1994, ISO/IEC 17025-2005, ISO 10012-1, the ISO 9000 family and QS 9000. The expanded uncertainties of measurements for this calibration are based upon 95% (2 sigma) confidence limits. Unless otherwise stated, a test accuracy ratio (TAR) of 4:1, if achievable, is maintained. The results reported herein apply only to the calibration of the item described above. This report may not be reproduced, except in full, without prior written consent of JJ Calibrations, Inc.  
JJ Calibrations, Inc. quality system has been assessed and accredited to ISO/IEC 17025:2005.

Reviewer

3 Issued 10/29/2018 Rev # 15

Inspector

# Thermal Metering System Calibration Y Factor

Manufacturer: Apex  
 Model: XC-60-EP  
 Serial Number: 0702003  
 OMNI Tracking No.: OMNI-00371  
 Calibrated Orifice:           

<b>Average Gas Meter y Factor</b>
<b>0.983</b>

<b>Orifice Meter dH@</b>
<b>N/A</b>

Calibration Date: 07/16/18  
 Calibrated by: B. Davis  
 Calibration Frequency: 6 months  
 Next Calibration Due: 1/16/2019  
 Instrument Range: 1.000 cfm  
 Standard Temp.: 68 oF  
 Standard Press.: 29.92 "Hg  
 Barometric Press., Pb: 30.08 "Hg  
 Signature/Date: *B. Davis* 7/16/2018

### Previous Calibration Comparison

Date	<u>1/16/2018</u>	Acceptable Deviation (5%)	Deviation
y Factor	<u>0.997</u>	0.04985	0.014
Acceptance	<b>Acceptable</b>		

### Current Calibration

Acceptable y Deviation	0.020
Maximum y Deviation	0.007
Acceptable dH@ Deviation	N/A
Maximum dH@ Deviation	N/A
Acceptance	<b>Acceptable</b>

### Reference Standard \*

Standard Calibrator	Model	Standard Test Meter
	S/N	<u>OMNI-00001</u>
	Calib. Date	<u>30-Oct-17</u>
	Calib. Value	<u>0.9977</u> y factor (ref)

Calibration Parameters	Run 1	Run 2	Run 3
Reference Meter Pressure ("H2O), Pr	0.00	0.00	0.00
DGM Pressure ("H2O), Pd	3.00	1.70	1.00
Initial Reference Meter	534.8	524	529.6
Final Reference Meter	540.302	529.514	534.7
Initial DGM	0	0	0
Final DGM	5.505	5.593	5.22
Temp. Ref. Meter (°F), Tr	85.0	82.0	81.0
Temperature DGM (°F), Td	85.0	83.0	84.0
Time (min)	28.8	35.5	47.8
Net Volume Ref. Meter, Vr	5.502	5.514	5.100
Net Volume DGM, Vd	5.505	5.593	5.22
<b>Gas Meter y Factor =</b>	<b>0.990</b>	<b>0.981</b>	<b>0.978</b>
<b>Gas Meter y Factor Deviation (from avg.)</b>	0.007	0.002	0.005
<b>Orifice dH@</b>	N/A	N/A	N/A
<b>Orifice dH@ Deviation (from avg.)</b>	N/A	N/A	N/A

where:

1. Deviation = |Average value for all runs - current run value|
- \*\* 2.  $y = [Vr \times (y \text{ factor (ref)}) \times (Pb + (Pr / 13.6)) \times (Td + 460)] / [Vd \times (Pb + (Pd / 13.6)) \times (Tr + 460)]$
- \*\* 3.  $dH@ = 0.0317 \times Pd / (Pb (Td + 460)) \times [(Tr + 460) \times \text{time}] / Vr]^2$

\* Reference calibration is traceable to NIST through NIST Test # 40674, Kimble ASTM E1272, or NIST traceable laboratory

\*\* Equations come from EPA Method 5

The uncertainty of measurement is  $\pm 0.14 \text{ ft}^3/\text{min}$ . This is based on the reference standard having a TAR (Test Accuracy Ratio) of at least 4:1.

## DIFFERENTIAL PRESSURE GAUGE CALIBRATION DATA SHEET

Instrument to be calibrated: Pressure Transducer

Maximum Range: 0-2" WC ID Number: OMNI-00371

Calibration Instrument: Digital Manometer ID Number: OMNI-00395

Date: 7/16/18 By: B. Davis

**This form is to be used only in conjunction with Standard Procedure C-SPC.**

Range of Calibration Point ("WC)	Digital Manometer Input ("WC)	Pressure Gauge Response ("WC)	Difference (Input - Response)	% Error of Full Span*
0-20% Max. Range 0 - 0.4	0.231	0.223	0.008	0.4
20-40% Max. Range 0.4 - 0.8	0.571	0.564	0.007	0.35
40-60% Max. Range 0.8 - 1.2	0.991	0.985	0.006	0.3
60-80% Max. Range 1.2 - 1.6	1.228	1.219	0.009	0.45
80-100% Max. Range 1.6 - 2.0	1.840	1.827	0.013	0.65

\*Acceptable tolerance is 4%.

The uncertainty of measurement is  $\pm 0.4$ " WC. This is based on the reference standard having a TAR (Test Accuracy Ratio) of at least 4:1.

Technician signature:  Date: 7/16/18

Reviewed by:  Date: 7/20/2018

Temperature Calibration EPA Method 28R, ASTM 2515							
BOOTH:	TEMPERATURE MONITOR TYPE:				EQUIPMENT NUMBER:		
Mobile	National Instruments Logger				00371, 00372		
REFERENCE METER EQUIPMENT NUMBER: 00373				Calibration Due Date: 8/02/17			
CALIBRATION PERFORMED BY:		DATE:		AMBIENT TEMPERATURE:		BAROMETRIC PRESSURE:	
B. Davis		7/17/18		76		30.12	
Input Temperature (F)	Ambient	Meter A					FB Interior
			Meter B	Filter A	Filter B	Tunnel	
0	0	0	0	0	0	1	1
100	100	100	100	100	100	101	100
300	299	300	300	300	299	300	300
500	499	500	500	499	499	500	500
700	699	700	700	699	699	700	700
1000	999	1000	1000	999	999	1000	1000

Input (F)	FB Top	FB Bottom	FB Back	FB Left	FB Right	Imp A	Imp B	Cat	Stack
0	1	1	1	1	1	-1	-1	-1	1
100	101	101	101	100	100	99	99	99	101
300	300	300	300	300	300	299	299	299	300
500	500	500	500	500	500	499	499	499	500
700	700	700	700	700	700	699	699	699	700
1000	1000	1000	1000	1000	1000	999	999	999	1000

1500  
2000

1499  
1999

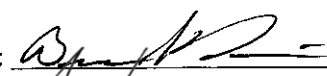
Technician signature:  Date: 7/17/18

Reviewed By:  Date: 7/20/18

# Thermal Metering System Calibration Y Factor

Manufacturer: Apex  
 Model: XC-60-EP  
 Serial Number: 0702004  
 OMNI Tracking No.: OMNI-00372  
 Calibrated Orifice:           

Date	1/17/2018	Acceptable Deviation (5%)	Deviation
y Factor	0.981	0.04905	0.007
Acceptance	Acceptable		

<b>Average Gas Meter y Factor</b> <b>0.974</b>
---

<b>Orifice Meter dH@</b> <b>N/A</b>
--

Calibration Date: 07/16/18  
 Calibrated by: B. Davis  
 Calibration Frequency: 6 months  
 Next Calibration Due: 1/16/2019  
 Instrument Range: 1.000 cfm  
 Standard Temp.: 68 oF  
 Standard Press.: 29.92 "Hg  
 Barometric Press., Pb: 30.08 "Hg  
 Signature/Date: *B. Davis* 7/16/2018

Acceptable y Deviation	0.020
Maximum y Deviation	0.008
Acceptable dH@ Deviation	N/A
Maximum dH@ Deviation	N/A
Acceptance	Acceptable

Standard	Model	Standard Test Meter
Calibrator	S/N	OMNI-00001
	Calib. Date	27-Oct-16
	Calib. Value	0.9977 y factor (ref)

Calibration Parameters	Run 1	Run 2	Run 3
Reference Meter Pressure ("H2O), Pr	0.00	0.00	0.00
DGM Pressure ("H2O), Pd	3.00	1.30	0.80
Initial Reference Meter	540.8	547.1	627.2
Final Reference Meter	547.004	552.102	633.4
Initial DGM	0	0	0
Final DGM	6.244	5.121	6.353
Temp. Ref. Meter (°F), Tr	86.0	88.0	88.0
Temperature DGM (°F), Td	85.0	87.0	87.0
Time (min)	27.5	34.5	56.5
Net Volume Ref. Meter, Vr	6.204	5.002	6.200
Net Volume DGM, Vd	6.244	5.121	6.353
<b>Gas Meter y Factor =</b>	<b>0.982</b>	<b>0.970</b>	<b>0.970</b>
<b>Gas Meter y Factor Deviation (from avg.)</b>	0.008	0.004	0.004
<b>Orifice dH@</b>	N/A	N/A	N/A
<b>Orifice dH@ Deviation (from avg.)</b>	N/A	N/A	N/A

where:

1. Deviation = |Average value for all runs - current run value|
- \*\* 2.  $y = [Vr \times (y \text{ factor (ref)}) \times (Pb + (Pr / 13.6)) \times (Td + 460)] / [Vd \times (Pb + (Pd / 13.6)) \times (Tr + 460)]$
- \*\* 3.  $dH@ = 0.0317 \times Pd / (Pb (Td + 460)) \times [(Tr + 460) \times \text{time}] / Vr^2$

\* Reference calibration is traceable to NIST through NIST Test # 40674, Kimble ASTM E1272, or NIST traceable laboratory

\*\* Equations come from EPA Method 5

The uncertainty of measurement is  $\pm 0.14 \text{ ft}^3/\text{min}$ . This is based on the reference standard having a TAR (Test Accuracy Ratio) of at least 4:1.

## DIFFERENTIAL PRESSURE GAUGE CALIBRATION DATA SHEET

Instrument to be calibrated: Pressure Transducer

Maximum Range: 0-2" WC ID Number: OMNI-00372

Calibration Instrument: Digital Manometer ID Number: OMNI-00395

Date: 7/16/18 By: B. Davis

**This form is to be used only in conjunction with Standard Procedure C-SPC.**

Range of Calibration Point ("WC)	Digital Manometer Input ("WC)	Pressure Gauge Response ("WC)	Difference (Input - Response)	% Error of Full Span*
0-20% Max. Range 0 - 0.4	0.037	0.042	0.005	0.25
20-40% Max. Range 0.4 - 0.8	0.512	0.509	0.003	0.15
40-60% Max. Range 0.8 - 1.2	1.169	1.164	0.005	0.25
60-80% Max. Range 1.2 - 1.6	1.540	1.533	0.007	0.35
80-100% Max. Range 1.6 - 2.0	1.772	1.776	0.004	0.20

\*Acceptable tolerance is 4%.

The uncertainty of measurement is  $\pm 0.4$ " WC. This is based on the reference standard having a TAR (Test Accuracy Ratio) of at least 4:1.

Technician signature:  Date: 7/16/18

Reviewed by:  Date: 7/20/2018





Temperature Calibration EPA Method 28R, ASTM 2515								
BOOTH:		TEMPERATURE MONITOR TYPE:				EQUIPMENT NUMBER:		
Mobile		National Instruments Logger				00371, 00372		
REFERENCE METER EQUIPMENT NUMBER: 00373					Calibration Due Date: 8/02/17			
CALIBRATION PERFORMED BY:			DATE:	AMBIENT TEMPERATURE:		BAROMETRIC PRESSURE:		
B. Davis			7/17/18	76		30.12		
Input Temperature (F)	Ambient	Meter A					Tunnel	FB Interior
			Meter B	Filter A	Filter B			
0	0	0	0	0	0	1	1	
100	100	100	100	100	100	101	100	
300	299	300	300	300	299	300	300	
500	499	500	500	499	499	500	500	
700	699	700	700	699	699	700	700	
1000	999	1000	1000	999	999	1000	1000	

Input (F)	FB Top	FB Bottom	FB Back	FB Left	FB Right	Imp A	Imp B	Cat	Stack
0	1	1	1	1	1	-1	-1	-1	1
100	101	101	101	100	100	99	99	99	101
300	300	300	300	300	300	299	299	299	300
500	500	500	500	500	500	499	499	499	500
700	700	700	700	700	700	699	699	699	700
1000	1000	1000	1000	1000	1000	999	999	999	1000

1500  
2000

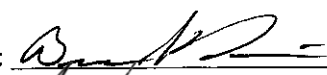
1499  
1999

Technician signature:  Date: 7/17/18  
 Reviewed By:  Date: 7/20/18

# Certificate of Calibration

Certificate Number: **686722**



**JJ Calibrations, Inc.**  
 7007 SE Lake Rd  
 Portland, OR 97267-2105  
 Phone 503.786.3005  
 FAX 503.786.2994

**Omni-Test Laboratories**  
 13327 NE Airport Way  
 Portland, OR 97230



PO: **180192**  
 Order Date: **10/22/2018**  
 Authorized By: **N/A**  
 Calibrated on: **10/30/2018**  
 \*Recommended Due: **10/30/2019**  
 Environment: **22 °C 44 % RH**  
 \* As Received: **Limited**  
 \* As Returned: **Limited**  
 Action Taken: **Calibrated**  
 Technician: **111**

Property #: **OMNI-00410**  
 User: **N/A**  
 Department: **N/A**  
 Make: **Dwyer**  
 Model: **1430**  
 Serial #: **OMNI-00410**  
 Description: **Microtector**  
 Procedure: **DCN 500908**  
 Accuracy: **±0.00025" WC**

Remarks: \* Many factors may cause the unit to drift out of calibration before the recommended due date. Any reported error is the absolute value between the reference and the unit. Uncertainties include the effects of the unit.

Previous limitation of micrometer head calibrated only continued. .001" reading micrometer head ±.001" (LSD) tolerance applied.

### Standards Used

Std ID	Manufacturer	Model	Nomenclature	Due Date	Trace ID
541A	Select	E8FED2	Gage Block Set, 8pc	12/18/2018	663864

### Measurement Data

Parameter	Measurement Description	Range	Unit	Reference	Min	Max	*Error	UUT	Uncertainty
<b>Before/After Length</b>									Accredited = ✓
		Inch		0.1300	0.129	0.131	0.001	0.129 Inch	1.1E-03 ✓
		Inch		0.3850	0.384	0.386	0.001	0.384 Inch	1.1E-03 ✓
		Inch		0.6150	0.614	0.616	0.001	0.614 Inch	1.1E-03 ✓
		Inch		0.8700	0.869	0.871	0.001	0.869 Inch	1.1E-03 ✓
		Inch		1.0000	0.999	1.001	0.001	0.999 Inch	1.1E-03 ✓

JJ Calibrations, Inc. certifies that this instrument has been calibrated in accordance with the JJ Calibrations Quality Assurance Manual with the stated procedure using standards that are traceable to the National Institute of Standards and Technology (NIST), or other National Measurement Institutes (NMI's), or by using natural physical constants, intrinsic standards or ratio calibration techniques. The quality system and this certificate are in compliance with ANSI/NC SL Z540-1-1994, ISO/IEC 17025-2005, ISO 10012-1, the ISO 9000 family and QS 9000. The expanded uncertainties of measurements for this calibration are based upon 95% (2 sigma) confidence limits. Unless otherwise stated, a test accuracy ratio (TAR) of 4:1, if achievable, is maintained. The results reported herein apply only to the calibration of the item described above. This report may not be reproduced, except in full, without prior written consent of JJ Calibrations, Inc.  
 JJ Calibrations, Inc. quality system has been assessed and accredited to ISO/IEC 17025:2005.

  
 Reviewer

3 Issued 10/31/2018 Rev # 15

  
 Inspector



## VWR Temperature Hygrometer Calibration Procedure and Data Sheet

Frequency: Every Two Years

Step 1: Locate NIST traceable standard.

Step 2: Place unit to be calibrated, tracking No. OMNI-00592, inside OMNI desiccate box on the same shelf with the NIST traceable standard.

Step 3: After a period of not less than four hours record the temperature and humidity of both units in the spaces provide below.

Step 4: If the unit to be calibrated matches the NIST standard within  $\pm 4\%$ , it is acceptable. If not, the unit needs to be sent to a repair company or replaced.

### Verification Data:

Date: 1/8/2018 Technician: B Davis

Time in desiccate: 0910 Recording time: 1335

NIST Standard Temperature: 28.3 °F NIST Standard Humidity: 74.5

Test Unit Temperature Reading: 25.4 °F Test Unit Humidity Reading: 74.3

Test unit OMNI- 00592 is X or was not      within acceptable limits.

Technician Signature: 

Comments: Full scale of OMNI-00592 is 90% RH, with a difference of 2.9 this gives a error percentage of 3.22%. This value is within the allowable 4%.

---

---

---

---

---

# ZRE

# NDIR/O<sub>2</sub>



# USER'S

# MANUAL



1312 West Grove Avenue  
Orange, CA 92865-4134  
Phone: 714-974-5560 Fax: 714-921-2531  
[www.gasanalyzers.com](http://www.gasanalyzers.com)

# Certificate of Calibration

Certificate Number: **692254**



**JJ Calibrations, Inc.**

7007 SE Lake Rd  
Portland, OR 97267-2105  
Phone 503.786.3005  
FAX 503.786.2994

**Omni-Test Laboratories**  
13327 NE Airport Way  
Portland, OR 97230

OnSite

PO: **181203**

Order Date: **01/11/2019**

Authorized By: **N/A**

Calibrated on: **01/11/2019**

\*Recommended Due: **07/11/2019**

Environment: **19 °C 43 % RH**

\* As Received: **Within Tolerance**

\* As Returned: **Within Tolerance**

Action Taken: **Calibrated**

Technician: **123**



Property #: **OMNI-00637**

User: **N/A**

Department: **N/A**

Make: **Mettler Toledo**

Model: **MS104TS/00**

Serial #: **B729400181**

Description: **Analytical Scale, 120g**

Procedure: **DCN 500887**

Accuracy: **±0.0005g**

Remarks: \* Many factors may cause the unit to drift out of calibration before the recommended due date. Any reported error is the absolute value between the reference and the unit. Uncertainties include the effects of the unit.

## Standards Used

Std ID	Manufacturer	Model	Nomenclature	Due Date	Trace ID
256A	Rice Lake	W0133K	Mass Set,	05/30/2019	660578

## Measurement Data

Parameter	Measurement Description	Range	Unit	Reference	Min	Max	*Error	UUT	Uncertainty
<b>Before/After Force</b>									Accredited = <b>U</b>
			g	10.00000	9.9995	10.0005	0.0000	10.0000 g	5.7E-04 <b>U</b>
			g	30.00000	29.9995	30.0005	0.0000	30.0000 g	5.7E-04 <b>U</b>
			g	60.00000	59.9995	60.0005	0.0002	59.9998 g	5.7E-04 <b>U</b>
			g	90.00000	89.9995	90.0005	0.0001	89.9999 g	5.7E-04 <b>U</b>
			g	120.00000	119.9995	120.0005	0.0002	119.9998 g	5.7E-04 <b>U</b>

JJ Calibrations, Inc. certifies that this instrument has been calibrated in accordance with the JJ Calibrations Quality Assurance Manual with the stated procedure using standards that are traceable to the National Institute of Standards and Technology (NIST), or other National Measurement Institutes (NMI's), or by using natural physical constants, intrinsic standards or ratio calibration techniques. The quality system and this certificate are in compliance with ANSI/NCSL Z540-1-1994, ISO/IEC 17025-2005, ISO 10012-1, the ISO 9000 family and QS 9000. The expanded uncertainties of measurements for this calibration are based upon 95% (2 sigma) confidence limits. Unless otherwise stated, a test accuracy ratio (TAR) of 4:1, if achievable, is maintained. The results reported herein apply only to the calibration of the item described above. This report may not be reproduced, except in full, without prior written consent of JJ Calibrations, Inc. JJ Calibrations, Inc. quality system has been assessed and accredited to ISO/IEC 17025:2005.

Reviewer

3 Issued 01/14/2019 Rev # 15

Inspector

# Certificate of Calibration

Certificate Number: **681844**



**JJ Calibrations, Inc.**  
 7007 SE Lake Rd  
 Portland, OR 97267-2105  
 Phone 503.786.3005  
 FAX 503.786.2994

**Omni-Test Laboratories**  
 13327 NE Airport Way  
 Portland, OR 97230

OnSite

PO: **180176**  
 Order Date: **08/07/2018**  
 Authorized By: **N/A**



Property #: **OMNI-00637**  
 User: **N/A**  
 Department: **N/A**  
 Make: **Mettler Toledo**  
 Model: **MS104TS/00**  
 Serial #: **B729400181**  
 Description: **Analytical Scale, 120g**  
 Procedure: **DCN 500887**  
 Accuracy: **±0.0005g**

Calibrated on: **08/07/2018**  
 \*Recommended Due: **02/07/2019**  
 Environment: **22 °C 38 % RH**  
 \* As Received: **Out of Tolerance**  
 \* As Returned: **Within Tolerance**  
 Action Taken: **Adjusted**  
 Technician: **III**

Remarks: \* Many factors may cause the unit to drift out of calibration before the recommended due date. Any reported error is the absolute value between the reference and the unit. Uncertainties include the effects of the unit.

Balance went into over range at max capacity. Adjusted balance to bring all points back into tolerance.

### Standards Used

Std ID	Manufacturer	Model	Nomenclature	Due Date	Trace ID
256A	Rice Lake	W0133K	Mass Set,	05/30/2019	660578

### Measurement Data

Parameter	Measurement Description	Range Unit	Reference	Min	Max	*Error	UUT	Uncertainty
<b>Before</b>	<b>Force</b>							Accredited = ✓
		g	10.00000	9.9995	10.0005	0.0004	10.0004 g	5.7E-04 ✓
		g	30.00000	29.9995	30.0005	0.0004	30.0004 g	5.7E-04 ✓
		g	60.00000	59.9995	60.0005	0.0004	60.0004 g	5.7E-04 ✓
		g	90.00000	89.9995	90.0005	0.0005	90.0005 g	5.7E-04 ✓
		g	120.00000	119.9995	120.0005	120.0000	0.0000 g	5.7E-04 ✓
<b>After</b>								Accredited = ✓
	g	10.00000	9.9995	10.0005	0.0000	10.0000 g	5.7E-04 ✓	
	g	30.00000	29.9995	30.0005	0.0001	29.9999 g	5.7E-04 ✓	
	g	60.00000	59.9995	60.0005	0.0001	60.0001 g	5.7E-04 ✓	
	g	90.00000	89.9995	90.0005	0.0002	89.9998 g	5.7E-04 ✓	
	g	120.00000	119.9995	120.0005	0.0002	119.9998 g	5.7E-04 ✓	

JJ Calibrations, Inc. certifies that this instrument has been calibrated in accordance with the JJ Calibrations Quality Assurance Manual with the stated procedure using standards that are traceable to the National Institute of Standards and Technology (NIST), or other National Measurement Institutes (NMI's), or by using natural physical constants, intrinsic standards or ratio calibration techniques. The quality system and this certificate are in compliance with ANSI/NCCL Z540-1-1994, ISO/IEC 17025-2005, ISO 10012-1, the ISO 9000 family and QS 9000. The expanded uncertainties of measurements for this calibration are based upon 95% (2 sigma) confidence limits. Unless otherwise stated, a test accuracy ratio (TAR) of 4:1, if achievable, is maintained. The results reported herein apply only to the calibration of the item described above. This report may not be reproduced, except in full, without prior written consent of JJ Calibrations, Inc.  
 JJ Calibrations, Inc. quality system has been assessed and accredited to ISO/IEC 17025:2005.

Reviewer:

3 Issued 08/09/2018 Rev # 15

Inspector:

### **3.3 - Example Calculations**



## Equations and Sample Calculations - ASTM E3053 & E2515

Manufacturer:	HHT Mt. Pleasant
Model:	Pioneer III
Run:	1 (Med)
Category:	Medium

Equations used to calculate the parameters listed below are described in this appendix. Sample calculations are provided for each equation. The raw data and printout results from a sample run are also provided for comparison to the sample calculations.

$M_{Bdb}$  - Weight of test fuel burned during test run, dry basis, kg

$M_{BSidb}$  - Weight of test fuel burned during test run segment  $i$ , dry basis, kg

BR - Average dry burn rate over full integrated test run, kg/hr

$BR_{Si}$  - Average dry burn rate over test run segment  $i$ , kg/hr

$V_s$  - Average gas velocity in the dilution tunnel, ft/sec

$Q_{sd}$  - Average gas flow rate in dilution tunnel, dscf/hr

$V_{m(std)}$  - Volume of Gas Sampled Corrected to Dry Standard Conditions, dscf

$m_n$  - Total Particulate Matter Collected, mg

$C_s$  - Concentration of particulate matter in tunnel gas, dry basis, corrected to standard conditions, g/dscf

$E_T$  - Total Particulate Emissions, g

PR - Proportional Rate Variation

$PM_R$  - Average particulate emissions for full integrated test run, g/hr

$PM_F$  - Average particulate emission factor for full integrated test run, g/dry kg of fuel burned

## Equations and Sample Calculations - ASTM E3053 & E2515

$M_{Bdb}$  - Weight of test fuel burned during test run, dry basis, kg

ASTM E3053 equation (1)

$$M_{Bdb} = (M_{Swb} - M_{Ewb})(100/(100 + FM))$$

Where,

- FM = average fuel moisture of test fuel, % dry basis
- $M_{Swb}$  = weight of test fuel in hopper at start of test run, wet basis, kg
- $M_{Ewb}$  = weight of test fuel in hopper at end of test run, wet basis, kg

Sample Calculation:

0 %

$$M_{Swb} = 47.3 \text{ lbs}$$

$$M_{Ewb} = 0.0 \text{ lbs}$$

0.4536 = Conversion factor from lbs to kg

$$M_{Bdb} = [(47.3 \times 0.4536) - (0.0 \times 0.4536)] (100/(100 + 0))$$

$$M_{Bdb} = 21.5 \text{ kg}$$

## Equations and Sample Calculations - ASTM E3053 & E2515

$M_{BSidb}$  - Weight of test fuel burned during test run segment  $i$ , dry basis, kg

ASTM E3053 equation (2)

$$M_{BSidb} = (M_{Ssiwb} - M_{Esiwb})(100/(100 + FM))$$

Where,

$M_{Ssiwb}$  = weight of test fuel in hopper at start of test run segment  $i$ , wet basis, kg

$M_{Esiwb}$  = weight of test fuel in hopper at end of test run segment  $i$ , wet basis, kg

Sample Calculation (from medium burn rate segment):

$$FM = 0 \quad \%$$

$$M_{Ssiwb} = 47.3 \text{ lbs}$$

$$M_{Esiwb} = 47.3 \text{ lbs}$$

0.4536 = Conversion factor from lbs to kg

$$M_{BSidb} = [(47.3 \times 0.4536) - (47.3 \times 0.4536)] (100/(100 + 0))$$

$$M_{BSidb} = 0 \text{ kg}$$

## Equations and Sample Calculations - ASTM E3053 & E2515

BR - Average dry burn rate over full integrated test run, kg/hr

ASTM E3053 equation (3)

$$BR = \frac{60 M_{Bdb}}{\theta}$$

Where,

$\theta$  = Total length of full intergrated test run, min

Sample Calculation:

$$M_{Bdb} = 21.46 \text{ kg}$$

$$\theta = 903 \text{ min}$$

$$BR = \frac{60 \times 21.5}{903}$$

$$BR = 1.43 \text{ kg/hr}$$

## Equations and Sample Calculations - ASTM E3053 & E2515

$V_s$  - Average gas velocity in the dilution tunnel, ft/sec

ASTM E2515 equations (9)

$$V_s = F_p \times K_p \times C_p \times (\sqrt{\Delta P})_{avg} \times \sqrt{\frac{T_s}{P_s \times M_s}}$$

Where:

- $F_p$  = djustment factor for center of tunnel pitot tube placement,  $F_p = \frac{V_{strav}}{V_{scent}}$ , ASTM E2515 Equation (1)
- $V_{scent}$  = Dilution tunnel velocity calculated after the multi-point pitot traverse at the center, ft/sec
- $V_{strav}$  = Dilution tunnel velocity calculated after the multi-point pitot traverse, ft/sec
- $k_p$  = Pitot tube constant, 85.49
- $C_p$  = Pitot tube coefficient: 0.99, unitless
- $\Delta P^*$  = Velocity pressure in the dilution tunnel, in H<sub>2</sub>O
- $T_s$  = Absolute average gas temperature in the dilution tunnel, °R; (°R = °F + 460)
- $P_s$  = Absolute average gas static pressure in diluion tunnel, =  $P_{bar} + P_g$ , in Hg
- $P_{bar}$  = Barometric pressure at test site, in. Hg
- $P_g$  = Static pressure of tunnel, in. H<sub>2</sub>O; (in Hg = in H<sub>2</sub>O/13.6)
- $M_s$  = \*\*The dilution tunnel wet molecular weight;  $M_s = 28.78$  assuming a dry weight of 29 lb/lb-mole

Sample calculation:

$$F_p = \frac{13.78}{15.04} = 0.917$$

$$V_s = 0.917 \times 85.49 \times 0.99 \times 0.225 \times \left( \frac{99.9 + 460}{29.43 + \frac{-0.20}{13.6}} \right)^{1/2} \times 28.78$$

$$V_s = 14.19 \text{ ft/s}$$

\*The ASTM test standard mistakenly has the square root of the average delta p instead of the average of the square root of delta p. The current EPA Method 2 is also incorrect. This was verified by Mike Toney at EPA.

\*\*The ASTM test standard mistakenly identifies  $M_s$  as the dry molecular weight. It should be the wet molecular weight as indicated in EPA Method 2.

## Equations and Sample Calculations - ASTM E3053 & E2515

$Q_{sd}$  - Average gas flow rate in dilution tunnel, dscf/hr

ASTM E2515 equation (3)

$$Q_{sd} = 3600 \times (1 - B_{ws}) \times v_s \times A \times \frac{T_{std}}{T_s} \times \frac{P_s}{P_{std}}$$

Where:

3600	=	Conversion from seconds to hours (ASTM method uses 60 to convert in minutes)
$B_{ws}$	=	Water vapor in gas stream, proportion by volume; assume 2%
A	=	Cross sectional area of dilution tunnel, ft <sup>2</sup>
$T_{std}$	=	Standard absolute temperature, 528 °R
$P_s$	=	Absolute average gas static pressure in dilution tunnel, = $P_{bar} + P_g$ , in Hg
$T_s$	=	Absolute average gas temperature in the dilution tunnel, °R; (°R = °F + 460)
$P_{std}$	=	Standard absolute pressure, 29.92 in Hg

Sample calculation:

$$Q_{sd} = 3600 \times (1 - 0.02) \times 14.19 \times 0.1963 \times \frac{528}{99.9 + 460} \times \frac{29.43 + \frac{-0.20}{13.6}}{29.92}$$

$$Q_{sd} = 9112.7 \text{ dscf/hr}$$

## Equations and Sample Calculations - ASTM E3053 & E2515

$V_{m(std)}$  - Volume of Gas Sampled Corrected to Dry Standard Conditions, dscf

ASTM E2515 equation (6)

$$V_{m(std)} = K_1 \times V_m \times Y \times \frac{P_{bar} + \left( \frac{\Delta H}{13.6} \right)}{T_m}$$

Where:

- $K_1$  = 17.64 °R/in. Hg
- $V_m$  = Volume of gas sample measured at the dry gas meter, dcf
- $Y$  = Dry gas meter calibration factor, dimensionless
- $P_{bar}$  = Barometric pressure at the testing site, in. Hg
- $\Delta H$  = Average pressure differential across the orifice meter, in. H<sub>2</sub>O
- $T_m$  = Absolute average dry gas meter temperature, °R

Sample Calculation:

Using equation for Train 1:

$$V_{m(std)} = 17.64 \times 135.417 \times 0.974 \times \frac{\left( 29.43 + \frac{1.38}{13.6} \right)}{\left( 75.7 + 460 \right)}$$

$$V_{m(std)} = 128.274 \text{ dscf}$$

Using equation for Train 2:

$$V_{m(std)} = 17.64 \times 134.584 \times 0.983 \times \frac{\left( 29.43 + \frac{1.81}{13.6} \right)}{\left( 77.4 + 460 \right)}$$

$$V_{m(std)} = 128.384 \text{ dscf}$$

Using equation for ambient train:

$$V_{m(std)} = 17.64 \times 0.00 \times 0 \times \frac{\left( 29.43 + \frac{0.00}{13.6} \right)}{\left( 73.4 + 460 \right)}$$

$$V_{m(std)} = 0.000 \text{ dscf}$$

## Equations and Sample Calculations - ASTM E3053 & E2515

$m_n$  - Total Particulate Matter Collected, mg

ASTM E2515 Equation (12)

$$m_n = m_p + m_f + m_g$$

Where:

$m_p$  = mass of particulate matter from probe, mg

$m_f$  = mass of particulate matter from filters, mg

$m_g$  = mass of particulate matter from filter seals, mg

Sample Calculation:

Using equation for Train 1 (first hour):

$$m_n = 0.0 + 15.5 + 0.0$$

$$m_n = 15.5 \text{ mg}$$

Using equation for Train 1 (remainder):

$$m_n = 2.0 + 5.4 + 1.2$$

$$m_n = 8.6 \text{ mg}$$

Train 1 Aggregate = **24.1 mg**

Using equation for Train 2:

$$m_n = 2.3 + 17.6 + 3.9$$

$$m_n = \mathbf{23.8 \text{ mg}}$$



## Equations and Sample Calculations - ASTM E3053 & E2515

$C_s$  - Concentration of particulate matter in tunnel gas, dry basis, corrected to standard conditions, g/dscf

ASTM E2515 equation (13)

$$C_s = K_2 \times \frac{m_n}{V_{m(\text{std})}}$$

Where:

$K_2$  = Constant, 0.001 g/mg

$m_n$  = Total mass of particulate matter collected in the sampling train, mg

$V_{m(\text{std})}$  = Volume of gas sampled corrected to dry standard conditions, dscf

Sample calculation:

For Train 1:

$$C_s = 0.001 \times \frac{24.1}{128.27}$$

$$C_s = 1.88\text{E-}04 \text{ g/dscf}$$

For Train 2

$$C_s = 0.001 \times \frac{23.8}{128.38}$$

$$C_s = 1.85\text{E-}04 \text{ g/dscf}$$

For Ambient Train

$$C_r = 0.001 \times \frac{0.0}{0.00}$$

$$C_r = 0.000000 \text{ g/dscf}$$

## Equations and Sample Calculations - ASTM E3053 & E2515

$E_T$  - Total Particulate Emissions, g

ASTM E2515 equation (15)

$$E_T = (c_s - c_r) \times Q_{std} \times \theta$$

Where:

- $C_s$  = Concentration of particulate matter in tunnel gas, g/dscf
- $C_r$  = Concentration particulate matter room air, g/dscf
- $Q_{std}$  = Average dilution tunnel gas flow rate, dscf/hr
- $\theta$  = Total time of test run, minutes

Sample calculation:

For Train 1

$$E_T = ( \underline{0.000188} - 0.000000 ) \times \underline{9112.7} \times \underline{903} / 60$$
$$E_T = \underline{25.77} \text{ g}$$

For Train 2

$$E_T = ( \underline{0.000185} - 0.000000 ) \times \underline{9112.7} \times \underline{903} / 60$$
$$E_T = \underline{25.42} \text{ g}$$

Average

$$E = \underline{25.60} \text{ g}$$

Total emission values shall not differ by more than 7.5% from the total average emissions

$$7.5\% \text{ of the average} = \underline{1.92}$$

$$\text{Train 1 difference} = \underline{0.17}$$

$$\text{Train 2 difference} = \underline{0.17}$$

## Equations and Sample Calculations - ASTM E3053 & E2515

### PR - Proportional Rate Variation

ASTM E2515 equation (16)

$$PR = \left[ \frac{\theta \times V_{mi} \times V_s \times T_m \times T_{si}}{\theta_i \times V_m \times V_{si} \times T_{mi} \times T_s} \right] \times 100$$

Where:

- $\theta$  = Total sampling time, min
- $\theta_i$  = Length of recording interval, min
- $V_{mi}$  = Volume of gas sample measured by the dry gas meter during the "ith" time interval, dcf
- $V_m$  = Volume of gas sample as measured by dry gas meter, dcf
- $V_{si}$  = Average gas velocity in the dilution tunnel during the "ith" time interval, ft/sec
- $V_s$  = Average gas velocity in the dilution tunnel, ft/sec
- $T_{mi}$  = Absolute average dry gas meter temperature during the "ith" time interval, °R
- $T_m$  = Absolute average dry gas meter temperature, °R
- $T_{si}$  = Absolute average gas temperature in the dilution tunnel during the "ith" time interval, °R
- $T_s$  = Absolute average gas temperature in the dilution tunnel, °R

Sample calculation (for the first 1 minute interval of Train 1):

$$PR = \left( \frac{903 \times 0.149 \times 14.19 \times (189.0 + 460) \times (75.7 + 460)}{1 \times 135.42 \times 14.83 \times (99.9 + 460) \times (77.0 + 460)} \right) \times 100$$

$$PR = \underline{110} \%$$

## Equations and Sample Calculations - ASTM E3053 & E2515

$PM_R$  - Average particulate emissions for full integrated test run, g/hr

ASTM E3053 equation (5)

$$PM_R = 60 (E_T / \theta)$$

Where,

$E_T$  = Total particulate emissions, grams

$\theta$  = Total length of full integrated test run, min

Sample Calculation:

$$E_T \text{ (Dual train average)} = 25.60 \text{ g}$$

$$\theta = 903 \text{ min}$$

$$PM_R = 60 \times ( 25.60 / 903 )$$

$$PM_R = 1.70 \text{ g/hr}$$

*Hearth & Home Technologies, Inc.  
Model: Pioneer III  
Report Number: 0061WF102E*

# **Appendix A – Labeling & Owner’s Manual**



UL 127-2011, CAN/ULC-S610



0061WF102E

# Model: Pioneer-III EPA CERTIFIED FIREPLACE



**NOTHING BURNS LIKE A QUAD**

A brand of Hearth & Home Technologies  
7571 - 215th Street West, Lakeville, MN. 55044  
www.quadrafire.com

SERIAL NO./NUMERO DESERE

MP182

MODEL/MODELE

PIONEER-III

FIRE CHAMBER INTENDED FOR USE WITH HEARTH & HOME TECHNOLOGIES LISTED FIREPLACE PARTS. SEE INSTALLATION AND OPERATING INSTRUCTIONS FOR THIS MODEL. REPLACE GLASS ONLY WITH CERAMIC.

DO NOT OVERFIRE. USE ONLY: SOLID WOOD FUEL. DO NOT USE A FIREPLACE INSERT OR OTHER PRODUCTS NOT SPECIFIED FOR USE WITH THIS PRODUCT.  
NE PAS surcuison. UTILISER UNIQUEMENT: COMBUSTIBLES SOLIDES OU BOIS COTÉES  
APPLIANCE DE GAZ DÉCORATIF. NE PAS UTILISER UN INSERT CHEMINEE OU AUTRES  
PRODUITS NON POUR USAGE SPÉCIFIÉ AVEC CE PRODUIT.

WARNING! THIS FIREPLACE HAS NOT BEEN TESTED WITH AN UNVENTED GAS LOG SET.  
TO REDUCE THE RISK OF FIRE OR INJURY,  
DO NOT INSTALL AN UNVENTED GAS LOG SET INTO FIREPLACE.  
AVERTISSEMENT! CE FOYER N'A PAS ÉTÉ TESTÉ AVEC UN  
JOURNAL DE GAZ NON APPROUVÉ. POUR RÉDUIRE LES RISQUES D'INCENDIE OU DE  
BLESSURES, N'INSTALLEZ PAS D'ENREGISTREMENT DE GAZ NON CONTINU AU FOYER.

DO NOT USE GRATE OR ELEVATE FIRE. BUILD WOOD FIRE DIRECTLY ON FIREBRICK.  
NE PAS UTILISER DE GRATE OU D'ÉLEVER UN FEU. CONSTRUISEZ UN FEU DE BOIS DIRECTEMENT SUR FIREBRICK.

WARNING! TO AVOID THE RISK OF DAMAGING FIREPLACE MATERIALS AND INCREASING THE RISK OF SPREADING A FIRE DO NOT USE THE  
FIREPLACE TO COOK OR WARM FOOD.  
ATTENTION! POUR ÉVITER LE RISQUE DE MATÉRIAUX ENDOMMAGER FOYER ET AUGMENTER LE RISQUE DE DIFFUSER UN  
INCENDIE NE PAS UTILISER LA FOYER À CHAUD DES ALIMENTS OU COOK.

FIREPLACE ALSO FOR USE  
IN MANUFACTURED/MOBILE  
HOMES WITH SOLID FUEL ONLY

YES  NO

FIREPLACE FOR USE  
OUTDOORS

YES  NO

CLEARANCE TO  
COMBUSTIBLES:  
DEGAGEMENT DES  
MATEAUX COMBUSTIBLES:

**CHIMNEY/CHEMNEE**  
**2 IN. MIN.**  
**51 MM**

		FIREBOX/ FOYER	
BACK	1	IN. MIN.	
RETOUR	25	MM MIN.	
SIDE	1-1/2	IN. MIN.	
COTÉ	38	MM MIN.	

IF INSTALLATION OR OPERATING INSTRUCTIONS ARE MISSING CONTACT:  
HEARTH & HOME TECHNOLOGIES,  
7571 215th Street West, Lakeville, MN 55044

This wood heater needs periodic inspection and repair for proper operation. Consult owner's manual for further information. It is against federal regulations to operate this wood heater in a manner inconsistent with the operating instructions in the owner's manual.

Cet appareil de chauffage au bois doit être inspecté et réparé périodiquement pour fonctionner correctement. Consultez le manuel du propriétaire pour plus d'informations. Il est contraire à la réglementation fédérale d'utiliser ce poêle à bois d'une manière non conforme aux instructions d'utilisation du manuel du propriétaire.

DO NOT REMOVE THIS LABEL  
NE PAS ENLEVER L'ÉTIQUETTE

Made in U.S.A. of US and imported parts  
Fabriqué aux États-Unis-d'Amérique par des pièces d'origine américaine et pièces importées.



2019 2020 2021 2022 2023 2024 Jan Feb Mar Apr May June July Aug Sept Oct. Nov. Dec.



U.S. ENVIRONMENTAL PROTECTION AGENCY - Certified to comply with 2020 particulate emission standards using cord wood.  
This wood heater was found to have an average emissions rate of 2.0g/hr using method ASTM E3053-17.

4182-990A

### NOTES:

1. Material: Metal
2. Copy: Black
3. Background: Silver
4. Size: 8" w x 5.5" h
5. Starting Serial No. MP182000001

					UNLESS OTHERWISE SPECIFIED: TOLERANCE - (2) PLACE DEC : ± 0.03 (3) PLACE DEC: ± 0.005 ANGLE: ± 2° FRACTION: ± 1/16					
					← OUTSIDE MATERIAL. ← NORMAL DIM & INSIDE MATERIAL. ← OUTSIDE APEX ← INSIDE APEX - DIMS ENCLOSED BY AN OVAL ARE CRITICAL DIMENSIONS					
					PART NAME: <b>Pioneer III Serial</b>					
					DRAWN BY: <b>pa</b>		SCALE: <b>NTS</b>		MATERIAL:	
					This print is checked and controlled by the engineering departments of Hearth & Home Technologies					
					SHEET: <b>1 OF 1</b>		PART NUMBER: <b>4182-990</b>		REV: <b>A</b>	
A Released		P16078		9/18		RG				
REV REVISIONS		ECO #		DATE		BY		Confidential property of Hearth & Home Technologies		

Bar Code Label  
1.5 in. x .400 in.

Bar code - 1st character  
must represent the letter S



Serial Number

# Owner's Manual

## Care and Operation

Pour demander un exemplaire en français de ce Manuel du propriétaire, visitez [www.quadra-fire.com/translations](http://www.quadra-fire.com/translations).

**INSTALLER:** Leave this manual with party responsible for use and operation.

**OWNER:** Retain this manual for future reference.

**NOTICE:** *DO NOT* discard this manual!

# QUADRA-FIRE®

Model(s):

**Pioneer-III-ABK**  
**Pioneer-III-RBK**

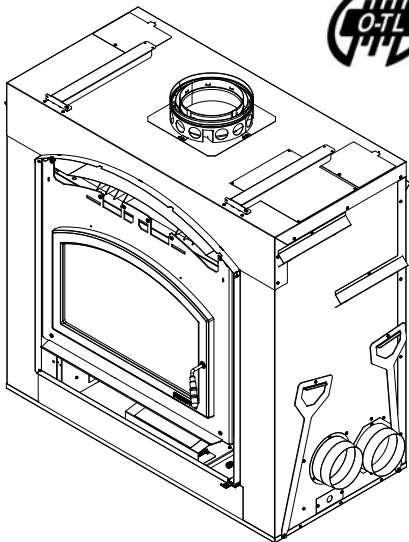

**EPA CERTIFIED WOODBURNING  
FIREPLACE**

Installation and service of this appliance should be performed by qualified personnel. Hearth & Home Technologies recommends HHT Factory Trained or NFI certified professionals.



**⚠ WARNING:** If the information in these instructions is not followed exactly, a fire or explosion may result causing property damage, personal injury, or death.

- **DO NOT** store or use gasoline or other flammable vapors and liquids in the vicinity of this or any other appliance.
- **DO NOT** overfire. Overfiring will void your warranty.
- Comply with all minimum clearances to combustibles as specified. Failure to comply may cause house fire.

### ⚠ WARNING



#### **HOT SURFACES!**

Glass and other surfaces are hot during operation AND cool down.

#### **Hot glass will cause burns.**

- **DO NOT** touch glass until it is cooled
  - **NEVER** allow children to touch glass
  - Keep children away
  - **CAREFULLY SUPERVISE** children in same room as fireplace.
  - Alert children and adults to hazards of high temperatures.
- High temperatures may ignite clothing or other flammable materials.**
- Keep clothing, furniture, draperies and other flammable materials away.

### ⚠ WARNING



#### **Fire Risk.**

For use with solid wood fuel only.  
Other fuels may overfire and generate poisonous gases (i.e. carbon monoxide).

## Safety Alert Key:

- **DANGER!** Indicates a hazardous situation which, if not avoided will result in death or serious injury.
- **WARNING!** Indicates a hazardous situation which, if not avoided could result in death or serious injury.
- **CAUTION!** Indicates a hazardous situation which, if not avoided, could result in minor or moderate injury.
- **NOTICE:** Indicates practices which may cause damage to the fireplace or to property.

## Table of Contents

<b>1 Welcome</b>		<b>4 Maintenance and Service</b>	
A. Congratulations	3	A. Maintenance Tasks-Homeowners	25
B. LIMITED LIFETIME WARRANTY	4	1. Chimney Inspection	25
<b>2 Product Specific Information</b>		2. Creosote (Chimney) Cleaning	26
A. Fireplace Certification	6	3. Care and Cleaning of Plated Surfaces	27
B. BTU & Efficiency Specifications	6	4. Glass Door	27
C. Mobile Home Approved	6	5. Glass Cleaning	27
D. Glass Specifications	6	6. Door Gasket	27
<b>3 Important Safety and Operating Information</b>		7. Ash Removal	27
A. Fireplace Safety	7	8. Baffle and Blanket	27
1. Clear Space	7	9. Firebrick	27
2. Firebrick	8	B. Replacement Maintenance	28
3. Baffle and Blanket	8	1. Glass Replacement	28
4. Over-Firing Your Fireplace	8	2. Tighten or Adjust Door Latch	28
5. Chimney Fire	8	3. Manifold Tubes Removal and Replacement	28
B. General Operating Parts	9	4. Door Handle Assembly	28
1. Smart Burn Technology System Activation	10	5. Firebrick Replacement	28
2. Thermostat Location & Wiring to Fireplace	11	6. Thermocouple Replacement	30
3. Programmable Wall Thermostat Install	12	7. Baffle Removal and Installation	31
4. Outside Air	16	8. Fan Replacement	31
5. Glass Doors	16	<b>5 Troubleshooting</b>	
6. Convection Fan Operation	16	A. FAQs	33
7. Battery Holder	16	B. Troubleshooting Table	35
C. Fuel	17	<b>6 Reference Materials</b>	
1. Hardwood vs. Softwood	18	A. Service Parts	38
2. Moisture Content	18	B. Contact Information	43
3. Seasoning	18		
4. Storing Wood	19		
5. Burning Process	19		
6. Dirty Glass	19		
7. Creosote Formation	19		
8. Opacity	19		
D. First Fire	19		
E. Lighting Instructions	20		
F. Heat Output Control	22		
G. Manual Override of Air Control	22		
H. Frequently Asked Questions	23		
I. Quick Start Guide	24		



# 1 Welcome

Read this manual before installing or operating this fireplace.  
Please retain this owner's manual for future references.

## A. Congratulations

Congratulations on selecting a Quadra-Fire wood burning fireplace. The Quadra-Fire fireplace you have selected is designed to provide the utmost in safety, reliability, and efficiency.

As the owner of a new fireplace, you'll want to read and carefully follow all of the instructions contained in this Owner's Manual. Pay special attention to all Cautions and Warnings.

This Owner's Manual should be retained for future reference. We suggest that you keep it with your other important documents and product manuals.

Your new Quadra-Fire wood burning fireplace will give you years of durable use and trouble-free enjoyment. Welcome to the Quadra-Fire family of fireplace products!

Quadra-fire is a registered trademark of Hearth & Home Technologies.

### Local Dealer Information

**DEALER:** Fill in your name, address, phone and email information here and fireplace information below.

Dealer Name: \_\_\_\_\_  
 Address: \_\_\_\_\_  
 \_\_\_\_\_  
 Phone: \_\_\_\_\_  
 Email: \_\_\_\_\_

#### Fireplace Information:

Brand: \_\_\_\_\_ Model Name: \_\_\_\_\_  
 Serial Number: \_\_\_\_\_ Date Installed: \_\_\_\_\_

### Listing Label Information/Location

The model information regarding your specific fireplace can be found on the rating plate usually located in the control area of the fireplace.

**Model:** Pioneer-III  
**EPA CERTIFIED FIREPLACE**

**QUADRA-FIRE**  
 NOTHING BURNS LIKE A QUAD

**SERIAL NO./NUMERO DESERE:** MP182  
**MODEL/MODELE:** PIONEER-III

**Model Number** (points to PIONEER-III)  
**Serial Number** (points to MP182)

**CHIMNEY/CHEMNEE CLEARANCE TO COMBUSTIBLES:**

BACK	1	IN. MIN.
RETOUR	25	MM MIN.
SIDE	1-1/2	IN. MIN.
COTE	38	MM MIN.

**DO NOT REMOVE THIS LABEL. NE PAS ENLEVER L'ETIQUETTE**

Mfg by: HEARTH & HOME technologies

2019 2020 2021 2022 2023 2024 Jan Feb Mar Apr May June July Aug Sept Oct. Nov. Dec.

U.S. ENVIRONMENTAL PROTECTION AGENCY - Certified to comply with 2020 particulate emission standards using cord wood.  
 This wood heater was found to have an average emissions rate of 2.0g/hr using method ASTM E3053-17.

4182-990A

## B. LIMITED LIFETIME WARRANTY

### Hearth & Home Technologies LIMITED LIFETIME WARRANTY

Hearth & Home Technologies, on behalf of its hearth brands (“HHT”), extends the following warranty for HHT gas, wood, pellet, coal and electric hearth appliances that are purchased from an HHT authorized dealer.

#### **WARRANTY COVERAGE:**

HHT warrants to the original owner of the HHT appliance at the site of installation, and to any transferee taking ownership of the appliance at the site of installation within two years following the date of original purchase, that the HHT appliance will be free from defects in materials and workmanship at the time of manufacture. After installation, if covered components manufactured by HHT are found to be defective in materials or workmanship during the applicable warranty period, HHT will, at its option, repair or replace the covered components. HHT, at its own discretion, may fully discharge all of its obligations under such warranties by replacing the product itself or refunding the verified purchase price of the product itself. The maximum amount recoverable under this warranty is limited to the purchase price of the product. This warranty is subject to conditions, exclusions and limitations as described below.

#### **WARRANTY PERIOD:**

Warranty coverage begins on the date of original purchase. In the case of new home construction, warranty coverage begins on the date of first occupancy of the dwelling or six months after the sale of the product by an independent, authorized HHT dealer/ distributor, whichever occurs earlier. The warranty shall commence no later than 24 months following the date of product shipment from HHT, regardless of the installation or occupancy date. The warranty period for parts and labor for covered components is produced in the following table.

The term “Limited Lifetime” in the table below is defined as: 20 years from the beginning date of warranty coverage for gas appliances, and 10 years from the beginning date of warranty coverage for wood, pellet, and coal appliances. These time periods reflect the minimum expected useful lives of the designated components under normal operating conditions.

Warranty Period		HHT Manufactured Appliances and Venting							Components Covered
Parts	Labor	Gas	Wood	Pellet	EPA Wood	Coal	Electric	Venting	
1 Year		X	X	X	X	X	X	X	All parts and material except as covered by Conditions, Exclusions, and Limitations listed
2 years				X	X	X			Igniters, electronic components, and glass
		X	X	X	X	X			Factory-installed blowers
			X						Molded refractory panels
		X							Ignition Modules
3 years				X					Firepots and burnpots
5 years	1 year			X	X				Castings and baffles
7 years	3 years		X	X	X				Manifold tubes, HHT chimney and termination
10 years	1 year	X							Burners, logs and refractory
Limited Lifetime	3 years	X	X	X	X	X			Firebox and heat exchanger
90 Days		X	X	X	X	X	X	X	All replacement parts beyond warranty period

See conditions, exclusions, and limitations on next page.

### **WARRANTY CONDITIONS:**

- This warranty only covers HHT appliances that are purchased through an HHT authorized dealer or distributor. A list of HHT authorized dealers is available on the HHT branded websites.
- This warranty is only valid while the HHT appliance remains at the site of original installation.
- This warranty is only valid in the country in which the HHT authorized dealer or distributor that sold the appliance resides.
- Contact your installing dealer for warranty service. If the installing dealer is unable to provide necessary parts, contact the nearest HHT authorized dealer or supplier. Additional service fees may apply if you are seeking warranty service from a dealer other than the dealer from whom you originally purchased the product.
- Check with your dealer in advance for any costs to you when arranging a warranty call. Travel and shipping charges for parts are not covered by this warranty.

### **WARRANTY EXCLUSIONS:**

This warranty does not cover the following:

- Changes in surface finishes as a result of normal use. As a heating appliance, some changes in color of interior and exterior surface finishes may occur. This is not a flaw and is not covered under warranty.
- Damage to printed, plated, or enameled surfaces caused by fingerprints, accidents, misuse, scratches, melted items, or other external sources and residues left on the plated surfaces from the use of abrasive cleaners or polishes.
- Repair or replacement of parts that are subject to normal wear and tear during the warranty period. These parts include: paint, wood, pellet and coal gaskets, firebricks, grates, flame guides, batteries and the discoloration of glass.
- Expansion, contraction, or movement of certain parts causing noise. These conditions are normal and complaints related to this noise are not covered by this warranty.
- Damages resulting from: (1) failure to install, operate, or maintain the appliance in accordance with the installation instructions, operating instructions, and listing agent identification label furnished with the appliance; (2) failure to install the appliance in accordance with local building codes; (3) shipping or improper handling; (4) improper operation, abuse, misuse, continued operation with damaged, corroded or failed components, accident, or improperly/incorrectly performed repairs; (5) environmental conditions, inadequate ventilation, negative pressure, or drafting caused by tightly sealed constructions, insufficient make-up air supply, or handling devices such as exhaust fans or forced air furnaces or other such causes; (6) use of fuels other than those specified in the operating instructions; (7) installation or use of components not supplied with the appliance or any other components not expressly authorized and approved by HHT; (8) modification of the appliance not expressly authorized and approved by HHT in writing; and/or (9) interruptions or fluctuations of electrical power supply to the appliance.
- Non-HHT venting components, hearth components or other accessories used in conjunction with the appliance.
- Any part of a pre-existing fireplace system in which an insert or a decorative gas appliance is installed.
- HHT's obligation under this warranty does not extend to the appliance's capability to heat the desired space. Information is provided to assist the consumer and the dealer in selecting the proper appliance for the application. Consideration must be given to appliance location and configuration, environmental conditions, insulation and air tightness of the structure.

### **This warranty is void if:**

- The appliance has been over-fired or operated in atmospheres contaminated by chlorine, fluorine, or other damaging chemicals. Over-firing can be identified by, but not limited to, warped plates or tubes, rust colored cast iron, bubbling, cracking and discoloration of steel or enamel finishes.
- The appliance is subjected to prolonged periods of dampness or condensation.
- There is any damage to the appliance or other components due to water or weather damage which is the result of, but not limited to, improper chimney or venting installation.

### **LIMITATIONS OF LIABILITY:**

- The owner's exclusive remedy and HHT's sole obligation under this warranty, under any other warranty, express or implied, or in contract, tort or otherwise, shall be limited to replacement, repair, or refund, as specified above. In no event will HHT be liable for any incidental or consequential damages caused by defects in the appliance. Some states do not allow exclusions or limitation of incidental or consequential damages, so these limitations may not apply to you. This warranty gives you specific rights; you may also have other rights, which vary from state to state. EXCEPT TO THE EXTENT PROVIDED BY LAW, HHT MAKES NO EXPRESS WARRANTIES OTHER THAN THE WARRANTY SPECIFIED HEREIN. THE DURATION OF ANY IMPLIED WARRANTY IS LIMITED TO DURATION OF THE EXPRESSED WARRANTY SPECIFIED ABOVE.

# 2 Listing and Code Approvals

## A. Appliance Certification

<b>Model:</b>	Pioneer III
<b>Laboratory:</b>	Underwriters Laboratories, Inc.
<b>Report No:</b>	Project 4788732172
<b>Type:</b>	Wood Fireplace
<b>Standard:</b>	UL 127 - 2011 and CAN/ULC S610-2018 (A1998) and (UM) 84-HUD, Manufactured Home Approved.

## B. BTU & Efficiency Specifications

EPA Certified Emissions:	2.0 grams per hour
*LHV Tested Efficiency:	74.3%
**HHV Tested Efficiency:	69.1%
***EPA BTU Output:	14,700-72,800
Vent Size:	8 inches
Firebox Size:	4.07 cubic feet
Recommended Log Length:	24 inches
Fuel	Seasoned Cord Wood less than 20% moisture
*Weighted average LHV (Low Heating Value) efficiency using cord wood and data collected during EPA emission test. LHV assumes the moisture is already in a vapor state so there is no loss in energy to vaporize.	
**Weighted average HHV (High Heating Value) efficiency using cord wood and data collected during EPA emission test. HHV includes the energy required to vaporize the water in the fuel.	
***A range of BTU outputs based on HHV and the burn rates from the low and high EPA tests, using cord wood.	

The Pioneer III is Certified to comply with 2020 particulate emission standards.



The PIONEER III Wood Appliance meets the U.S. ENVIRONMENTAL PROTECTION AGENCY Certified to comply with 2020 particulate emission standards using cord wood.

This wood heater needs periodic inspection and repair for proper operation. It is against federal regulations to operate this wood heater in a manner inconsistent with operating instructions in this manual.

## C. Mobile Home Approved

- This appliance is approved for mobile home installations when not installed in a sleeping room and when an outside combustion air inlet is provided.
- The structural integrity of the mobile home floor, ceiling, and walls must be maintained.
- The appliance must be properly grounded to the frame of the mobile home with #8 copper ground wire.
- Outside Air Kit must be installed in a mobile home installation.

## D. Glass Specifications

This fireplace is equipped with 5mm ceramic glass. Replace glass only with 5mm ceramic glass. Please contact your dealer for replacement glass.

### WARNING



#### Fire Risk.

Hearth & Home Technologies disclaims any responsibility for, and the warranty will be voided by, the following actions:

- Installation and use of any damaged appliance.
- Modification of the appliance.
- Installation other than as instructed by Hearth & Home Technologies.
- Installation and/or use of any component part not approved by Hearth & Home Technologies.
- Operating appliance without fully assembling all components.
- Do NOT Overfire - If appliance or chimney connector glows, you are overfiring.

Any such action that may cause a fire hazard.

Improper installation, adjustment, alteration, service or maintenance can cause injury or property damage.

For assistance or additional information, consult a qualified installer, service agency or your dealer.

NOTE: Hearth & Home Technologies, manufacturer of this appliance, reserves the right to alter its products, their specifications and/or price without notice.

Quadra-Fire is a registered trademark of Hearth & Home Technologies.

# 3 Important Safety and Operating Information

## A. Fireplace Safety

Most problems are caused by improper installation and operation of the fireplace. To provide reasonable fire safety, the following should be given serious consideration:

- The fire should be supervised whenever the fireplace is in use.
- An annual inspection should be performed on the fireplace system.
- Install at least one smoke detector on each floor of your home to ensure your safety.
- Install a CO detector in the room with the fireplace.
- Install a conveniently located Class A fire extinguisher near the fireplace.
- Devise a practiced evacuation plan, consisting of at least two escape routes.
- Devise a plan to deal with a chimney fire:
  - Close all openings into the fireplace.
  - Evacuate.
  - Notify the fire department.

**WARNING! Risk of Fire!** *Hearth & Home Technologies disclaims any responsibility for, and the warranty and agency listing will be voided by the following actions.*

### DO NOT:

- operate damaged fireplace
- modify fireplace
- overfire
- install any gas log set
- install any component not approved by *Hearth & Home Technologies*
- install parts or components not Listed or approved
- operate the fireplace without fully assembling all components

*Improper installation, adjustment, alteration, service or maintenance can cause injury or property damage.*

 **WARNING:** This product and the fuels used to operate this product (wood and wood pellets), and the products of combustion of such fuels, can expose you to chemicals including carbon black, which is known to the State of California to cause cancer and carbon monoxide, which is known to the State of California to cause birth defects or other reproductive harm. For more information go to: [www.P65Warnings.ca.gov](http://www.P65Warnings.ca.gov).

## 1. Clear Space

Combustible materials must not be stored on the hearth extension. Room furnishings such as drapes, curtains, chairs or other combustibles must be at least 4 ft (1219 mm) from the open front of the fireplace.

Combustible materials are materials made of or surfaced with any of the following materials:

- Wood
- Plant fibers
- Plywood/OSB
- Compressed paper
- Plastic
- Drywall
- Any material that can ignite and burn, flame proofed or not, plastered or un-plastered.

Non-combustible materials are materials which will not ignite and burn, composed of any combination of the following:

- Steel
- Brick
- Concrete
- Glass
- Iron
- Tile
- Slate
- Plasters

**WARNING! Risk of Fire!** *Keep combustible materials, gasoline and other flammable vapors and liquids clear of the fireplace.*

### DO NOT:

- store flammable materials close to the fireplace
- use gasoline, lantern fuel, kerosene, charcoal lighter fluid or similar liquids to start or “freshen up” a fire in this fireplace.

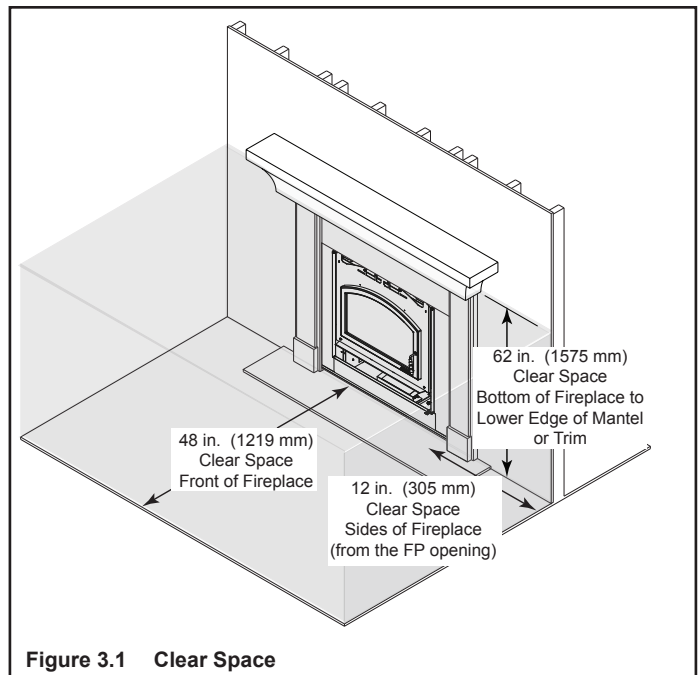

## 2. Firebrick

Your fireplace is lined with high quality firebrick, which has exceptional insulating properties.

Do not operate the fireplace without bricks. Make sure bricks are installed as shown in Section 5.

Do not use a grate; simply build a fire on the firebox floor.

## 3. Baffle and Blanket

Ensure correct baffle and baffle protection channel placement; replace baffle components if damaged or missing. (Please refer to Section 5.)

**NOTICE:** Firebox damage due to improper baffle placement is not covered by warranty. Operate the wood burning fireplace with the baffle in the correct position only. Not doing so could result in:

- reduced efficiency
- overheating the chimney
- overheating the rear of the firebox
- poor performance

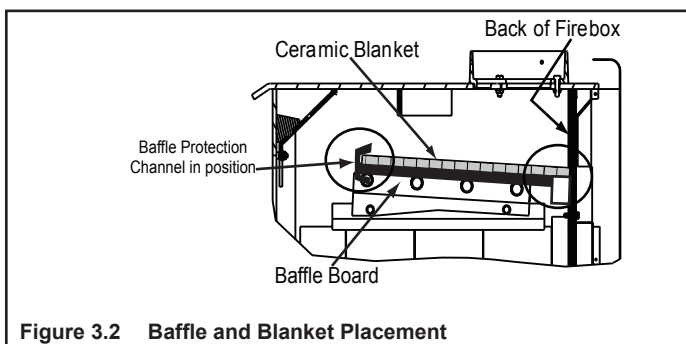

The baffle board must be in contact with the manifold at the back of the firebox. The ceramic blanket should lay on top of the baffle board and manifold.

The baffle protection channel should be in position and cover the front of the blanket and baffle board.

## 4. Over-Firing Your Fireplace

### DO NOT OVERFIRE THIS FIREPLACE UNIT

Attempts to achieve heat output rates that exceed design specifications can result in permanent damage to the fireplace.

To prevent over-firing your fireplace. **DO NOT:**

- use flammable liquids
- overload with wood
- burn trash or large amounts of scrap lumber
- permit too much air to the fire (leaving the door open)

Symptoms of over-firing may include one or more of the following:

- chimney connector or fireplace glowing
- roaring, rumbling noises
- loud cracking or banging sounds
- metal warping
- chimney fire

What to do if your fireplace is over-firing:

- Immediately close the door and air controls to reduce air supply to the fire.
- If you suspect a chimney fire, call the fire department and evacuate your house.
- Contact your local chimney professional and have your fireplace and chimney inspected for any damage.
- Do not use your fireplace until the chimney professional informs you it is safe to do so.
- Hearth & Home Technologies WILL NOT warranty fireplaces that exhibit evidence of over-firing. Evidence of over-firing includes, but is not limited to:
  - warped air tube
  - deteriorated refractory brick
  - deteriorated baffle and other interior components

## 5. Chimney Fire

In the event of a chimney fire:

- Have the chimney and adjacent structure inspected by qualified professionals. Hearth & Home Technologies recommends that NFI or CSIA certified professionals, or technicians under the direction of certified professionals, conduct a minimum of an **NFPA 211 Level 2** inspection of the chimney.
- Replace components of the chimney and fireplace as specified by the professionals.
- Ensure all joints are properly engaged and the chimney is properly secured.

**WARNING! Risk of Fire!** A chimney fire can permanently damage your chimney system. Failure to replace damaged components and make proper repairs can cause a structure fire.

## WARNING



### HOT SURFACES!

Glass and other surfaces are hot during operation AND cool down.

### Hot glass will cause burns.

- **DO NOT** touch glass until it is cooled
- NEVER allow children to touch glass
- Keep children away
- CAREFULLY SUPERVISE children in same room as fireplace.
- Alert children and adults to hazards of high temperatures.

### High temperatures may ignite clothing or other flammable materials.

- Keep clothing, furniture, draperies and other flammable materials away.

## B. General Operating Parts

**WARNING! DO NOT** operate fireplace before reading and understanding operating instructions. Failure to operate fireplace according to operating instructions could cause fire or injury.

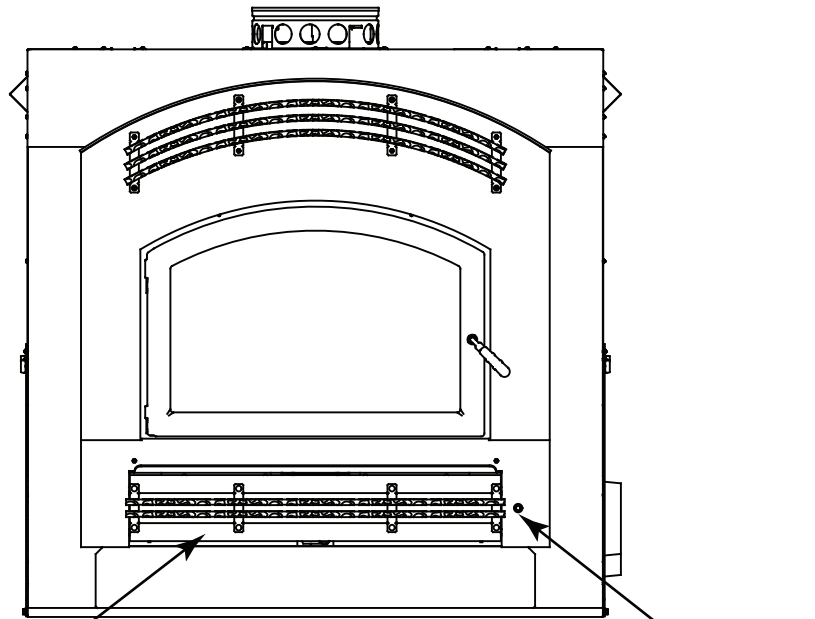

Bottom access cover, outside air control, and fan speed control are located in behind the access panel.

SBT Button

Figure 3.3 General Operating Parts

## 1. Smart Burn Technology (SBT)

The Smart Burn Technology system allows the thermostat to be set at the desired temperature, start the fire, load the appliance with wood and it will burn efficiently and clean with little interaction by the homeowner.

Battery Backup allows the appliance to operate without 110V but will not operate optional BK-350 fan.

The appliance can be also operated manually if necessary.

### SMART Burn Technology Activation

**Pushing the button will activate the appliance and open the air control to high.**

#### **Green Light**

The green light illuminates when the button is pressed. This is indicating that the appliance is ready for a new fire or a reload. If neither of these events happens, the light will stay on for 2 hours and the air control will stay open. After 2 hours of no heat rise in the appliance then the light will go out and the air control closes to the zero position.

If a fire is started or the appliance is reloaded, the light will stay on through the warm up cycle. If the thermostat is calling for heat then the light stays green for as long as the appliance is burning on high.

#### **No Light**

The appliance will progress into a shutdown phase and slowly cool down and the light will turn off. Everything is working OK, but the SBT button will need to be pushed when reloading fuel.

#### **Red Light**

When the thermostat calls for heat while the appliance is in charcoal phase, the air control will open all the way and the red light illuminates. This is indicating that the appliance is trying to heat the room but there is only charcoal left and needs reloaded.



## 2. Thermostat Location and Wiring to Fireplace

The kit comes with a programmable wall thermostat (C1) and 25' of thermostat wire (C2). If you need to run more than 25' make sure you use a continuous strand of 18 to 22 gauge thermostat wire. For optimum performance your thermostat should be:

- Mounted on an inside wall, approximately 5' above the floor
- Do not locate where there is poor air circulation such as in a corner, alcove, behind doors, bookcase or other objects
- Located away from drafts, direct sunlight, above a lamp, television, radiator, a wall next to a window, or direct heat from the appliance
- Avoid damp environments as this can lead to corrosion that may shorten thermostat life
- If painting or construction work around, cover the thermostat completely or wait until work is complete before installation.
- The thermostat wire will be installed on the opposite side of where the electric comes in at. See Figure 3.6.

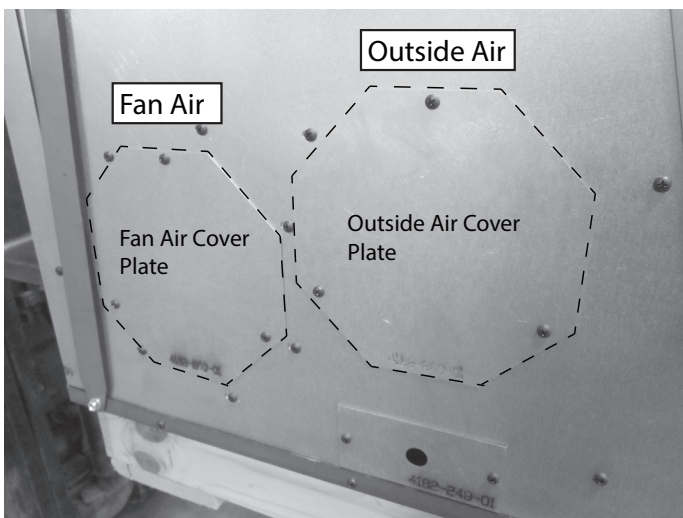

Figure 3.6

- Insert the end of the wire with the spade ends on it through the hole in the bottom cover plate on the outside of the fireplace.
- Open the lower access panel on the front of the fireplace. Locate the end of the thermostat wire and run it in through from the back of the large hole and up to and attach it to the terminal block. See Figure 3.7.

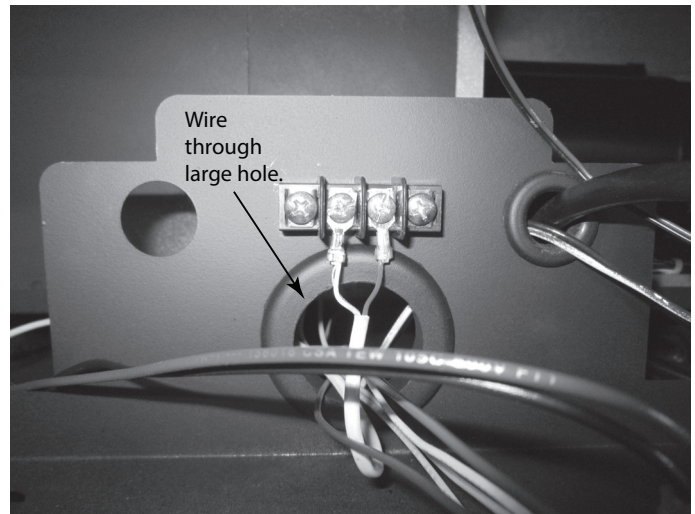

Figure 3.7

- Using the strain relief, place the thermostat wire in it making sure that there is plenty of wire length into the terminal block. Close the strain relief and push it into the hole. See Figure 3.8.

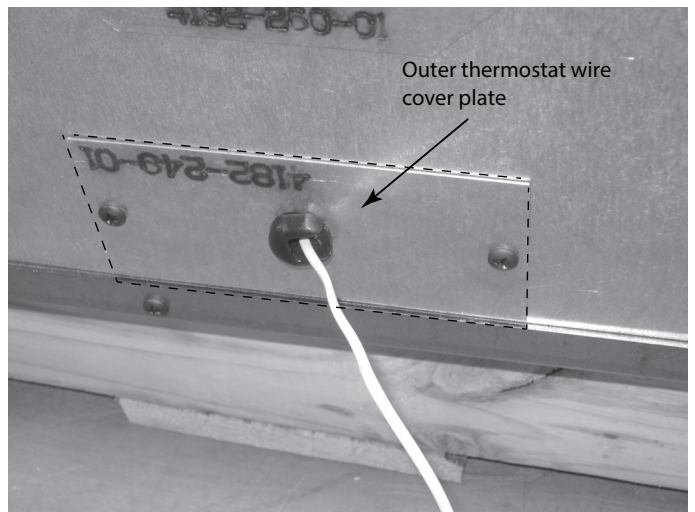

Figure 3.8

### 3. Programmable Wall Thermostat Installation

1. Separate the body of the thermostat from the mounting plate by gently pulling the two pieces apart. See Figure 3.9.

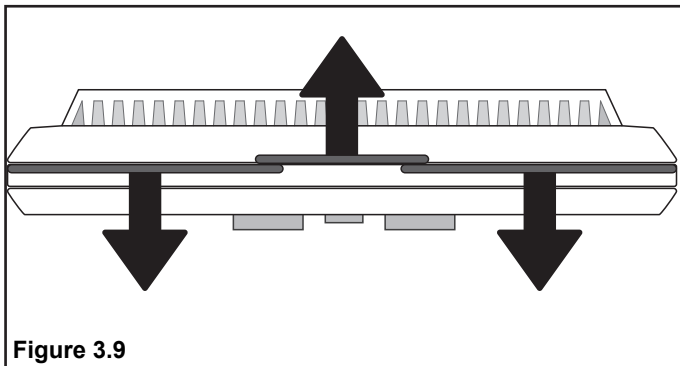

Figure 3.9

2. Use a drill with either a 3/16 drill bit for drywall or a 7/32 drill bit for plaster drill holes.
3. Using a hammer tap in wall anchors.
4. Route the wires through the opening in the base plate, and hold the base against the wall while aligning up to the holes. Attach base plate using a Phillips head screwdriver and two screws (C2).
5. Connect your thermostat wire to the W and R terminals. See Figure 3.10.

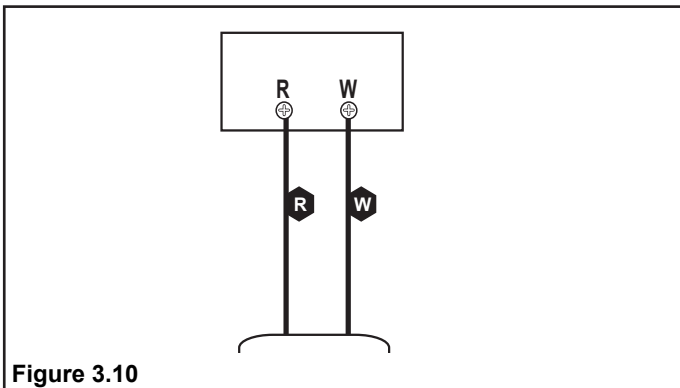

Figure 3.10

**NOTE:** Ensure bare wire ends are held ALL the way into the terminal block while the screws are being tightened.

6. There are two **AA ALKALINE ONLY** batteries already installed into the thermostat; to activate, remove black plastic tab that is located inside the battery compartment.

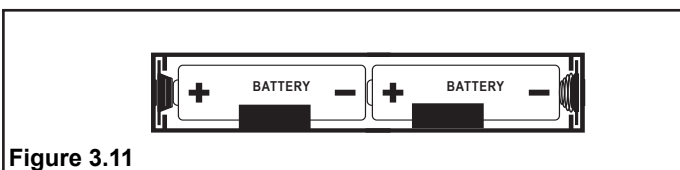

Figure 3.11

7. Snap the thermostat to the base plate.

### Thermostat Controls

#### TEMPERATURE (HEAT / OFF) SWITCH:

Set this switch to HEAT to control your appliance. The OFF position will disable the appliance.

#### SET (MULTI- FUNCTION) SLIDE SWITCH:

This provides easy access to common settings, and should always remain in RUN unless items are being adjusted.

**NOTE:** When thermostat is set to “Manual” non-programmable mode, all positions of the SET slide switch will act like RUN.

#### UP / DOWN BUTTONS:

The UP and DOWN buttons are used to control the set temperature, or adjust any other on-screen items. An items flashing, is the item currently being adjusted.

#### HOLD BUTTON:

This button activates and deactivates the manual Temperature HOLD feature, which maintains a fixed set temperature indefinitely without following a program routine.

#### COPY BUTTON:

This is used to copy temperature program items from one day to the next. Also used to access the menu setup.

#### NEXT BUTTON:

This is used when setting items such as software options, and temperature programs when they are flashing on the screen. Pressing the NEXT button will cycle through which item is flashing.

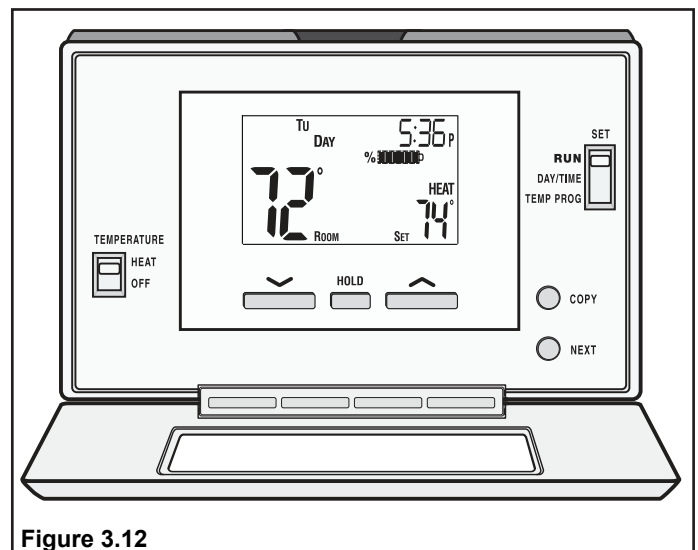

Figure 3.12

## Thermostat Setup Options

Setup options for how the thermostat will function are performed using a menu on the display screen.

### TO ACCESS THE SETUP MENU:

Move the System Mode Switch into the OFF position, and then hold down the COPY button for approximately 5 seconds until the screen changes. The menu will always start with item #01, and is advanced to each following item by a single press of the NEXT button. The options for each item are changed using the UP or DOWN buttons.

#### ITEM #01 (CLK = CLOCK FORMAT):

- 12Hr, default: This displays the clock times using standard AM and PM values.
- 24Hr: This displays the clock times using the military-time format (example 22:00 hours, without using AM or PM).

#### ITEM #02 (TMP = TEMPERATURE SCALE):

- F, default: Shows all temperature values in Fahrenheit.
- C: Shows all temperature values Celsius.

#### ITEM #03 (PROGRAMMING STYLE):

- 7 Day, default: This style uses a separate program routine for each of the 7 days in the week.
- 5/2 Day: This style uses a weekday program routine for Monday, Tuesday, Wednesday, Thursday, Friday, and a separate weekend program routine for Saturday and Sunday.
- Manual Non-Programmable: In this setting, there are no program routines for the thermostat to follow and the temperature control will be set only by the UP and DOWN buttons on the front panel.

#### ITEM #04 (PERD = EVENT OR PERIOD QUANTITY):

- 4P, default: Thermostat uses four Events per day (called MORN, DAY, EVE, and NITE).
- 2P: The thermostat uses two Events per day (called DAY and NITE).

**NOTE:** Event or Period Quantity feature is not accessible during Manual Non-Programmable mode.

#### ITEM #07 (DLAY = DELAY TIME):

- 5, default: Thermostat waits 5 minutes before turning the system back on after it was last run. This internal delay prevents the appliance from turning on too quickly after shutting down. The 5 minute setting is fine for most applications.
- 2: Same operation as above but reduced to 2 minutes between state changes. **NOTE:** This delay does not happen when the thermostat is manually turned up and down.

#### ITEM #08 (TEMPERATURE DIFFERENTIAL):

- The thermostat works by turning your heating system on and off whenever the room temperature varies from the desired set-point temperature.

- Use the UP/DOWN buttons to change the number value between 1 and 9. Generally your system should cycle on about 3 to 6 times per hour. A smaller differential number makes the system cycle more frequently, so the room temperature is more precise and constant. A larger differential number will make the system remain on for a longer duration each time and decreases the number of cycles per hour.
- Default is set to 4.

## Operating Instructions

### SET DAY AND TIME:

Place the SET switch into the DAY/TIME position. With the day flashing press UP or DOWN to set the day or the week. Press NEXT and the clock time will start flashing. Use UP or DOWN to set the time; verify the AM/PM indicator is correct. Return the SET switch to RUN position when finished.

### HEATING:

Basic operation of the thermostat can be obtained with the SET switch in the RUN position. The temperature can be adjusted using the UP and DOWN buttons. When the thermostat is first powered on, it will follow a default temperature routine that is preset from the factory.

Event	Time	Temperature
MORN	6:00 AM	70°F (21°C)
DAY	8:00 AM	62°F (17°C)
EVE	6:00 PM	70°F (21°C)
NITE	10:00 PM	62°F (17°C)

### LCD DISPLAY BACKLIGHT:

The display screen is lighted to assist viewing at night-time, or in locations with low light levels. Press any button on the front panel to activate the approximate 10 second backlight.

### TEMPERATURE OVERRIDE:

While thermostat is in RUN mode, the set temperature can be temporarily changed by pressing UP or DOWN. The temporarily changed set temperature will return to the programmed value stored in memory when start time of the next upcoming scheduled event is reached (MORN, DAY, EVE, OR NITE). While the temporary changed set temperature is in effect, the word OVERRIDE will be shown on the display screen. To cancel, move TEMPERATURE switch to OFF and back to HEAT again.

### TEMPERATURE HOLD:

Temperature hold is used for maintaining a fixed set temperature; once a HOLD is initiated, the thermostat will maintain the set temperature indefinitely. To enter a HOLD state, press the HOLD button one time and the word HOLD will appear on the display. To cancel, press the HOLD button once again.

## STATIC NOTICE

Thermostat is protected against normal static electric discharges, however to minimize the risk of damaging the thermostat in extremely dry weather, please touch a grounded metal object before touching the thermostat.

## Temperature Programs

The thermostat by default has 4 separate program events they are: MORN, DAY, EVE, and NITE. Each event ends at the start time of the following event.

**NOTE:** If the thermostat is set for 2 events a day instead of 4, the thermostat will only use the DAY and NITE events.

## SET TEMPERATURE PROGRAMS:

1. Move TEMPERATURE switch to HEAT.
2. Move SET switch to TEMP PROG position.
3. Starting with Monday, use the UP or DOWN buttons to adjust the start time and set temperature for the MORN event, and then press NEXT button to advance.
4. Adjust the start time and set temperature of the DAY event then press NEXT button.
5. Continue in this same manner to adjust the start time and set temperatures for the EVE and NITE events for Monday.

**NOTE:** When the last event is finished for each day or group of days, the thermostat will advance forward into the next day or group of days.

6. Use steps 3 through 5 to set up the events for the rest of the week or group of days.
7. Return the SET switch back to RUN.

## COPY PROGRAM FEATURE:

Using similar instructions as **SET TEMPERATURE PROGRAMS** the COPY button will allow a whole day of set program events to be copied to another day.

1. Move TEMPERATURE switch to HEAT as well as move SET switch to TEMP PROG position.
2. Starting with Monday, use the UP or DOWN buttons to adjust the start time and set temperature for the MORN, DAY, EVE, and NITE events. Press the COPY button and then press the NEXT button to advance to Tuesday.
3. With Tuesday displayed press COPY button. As all programs events from Monday will be copied to Tuesday (this will advance automatically to the next day; Wednesday, as the word COPY will appear on the screen for one second).
4. Continue in this pressing COPY button to set desired days with original setting.

**NOTE:** The word COPY will not appear on the display for Monday, but will display each day afterwards for approximately one second and the day of the week will automatically advance forward to the next day.

## Other Features

**NOTE:** All other features need to be completed in a timely manner as the thermostat will time out after 10 seconds.

## TEMPERATURE CALIBRATION:

The internal temperature sensor in this thermostat is accurately calibrated at the factory, and in most cases alterations to this setting should not be needed. The temperature calibration feature allows you to manually offset the measured temperature by as much as plus or minus 5°F (3°C) from its original value. If several thermostats are used in the same house, this feature can be used to synchronize this thermostat to the others.

### Change the temperature calibration:

1. Move TEMPERATURE switch to OFF.
2. Move SET switch to RUN.
3. Press and hold both UP and DOWN buttons together for at least 5 seconds; the words SET and CAL will appear on the display along with a single flashing temperature digit.
4. Use the UP or DOWN buttons to change the number of degrees desired for adjustment; 0° is the default value and also means no correction will be applied.
5. Press the NEXT button to accept the setting.

## KEYPAD LOCKOUT:

There is the option to lock the front panel buttons to prevent unauthorized tampering of your thermostat settings.

### To Lock the Keypad:

1. Move TEMPERATURE switch to HEAT.
2. Move SET switch to RUN.
3. Perform a single press of each button in the following sequence:
  - NEXT, NEXT, NEXT, HOLDA padlock will appear on the display screen.

### To Unlock the Keypad:

1. Move TEMPERATURE switch to HEAT.
2. Move SET switch to RUN.
3. Perform a single press of each button in the following sequence:
  - NEXT, NEXT, NEXT, HOLDA padlock will no longer be present on the display screen.

### HARDWARE RESET:

The hardware reset button; labeled HW RST, is a small round push button that is located in the middle of the circuit board, just below the battery holder (**Figure 3.13**). Pressing this button will:

- Cause the LCD display screen to become fully populated
- Thermostat to perform an internal system check of its components

If the thermostat appears to be acting in an erratic manner, pressing the HW RST button may remedy this behavior. The temperature programs are not erased when a hardware reset is performed, however the clock will have to be changed to match the current day and time.

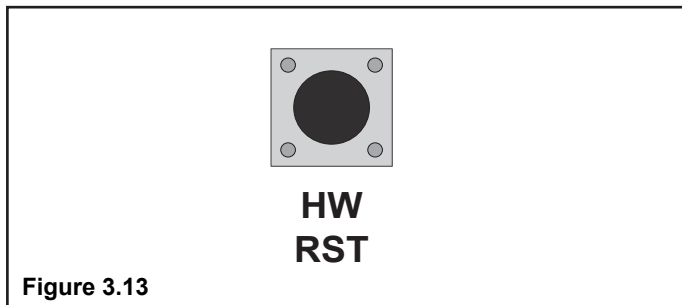

### SOFTWARE RESET:

Software reset is used to erase ALL temperature events, and to return all user-adjustable software settings back to their original factory default settings.

To Perform a Software Rest:

1. Verify the thermostat's keypad is not locked.
2. Move TEMPERATURE switch to OFF.
3. Press and hold the UP, DOWN, and NEXT buttons all at the same time for at least 5 seconds. When the LCD display screen will become fully populated let go of all buttons at that point the screen will return to normal.

The clock will have to be changed to match the current day and time.

### Battery Replacement

This thermostat is powered by two "AA" Alkaline batteries. The batteries should be replaced AT LEAST once per year to ensure reliable operation or sooner if the LO BATT appears on the display screen. The batteries are located on the back of the thermostat's circuit board. The front portion of the thermostat can be removed from the back half by using the tabs on the top edge of the thermostat housing (**Figure 3.9 on page 12**).

When installing new batteries, it is recommended using only brand new "AA" size alkaline batteries. Please verify the polarity markings shown in the battery compartment before adding batteries to the compartment. When finished, line up the front of the thermostat to the base, and firmly press together to securely latch the front and back halves together properly.

### BATTERY GRAPHIC:

Anytime time the batteries are physically present in the thermostat, there will be a visual indicator showing the life of the battery. This will appear on the display screen (**Figures 3.14 & 3.15**)

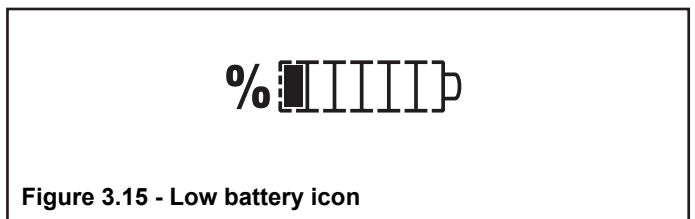
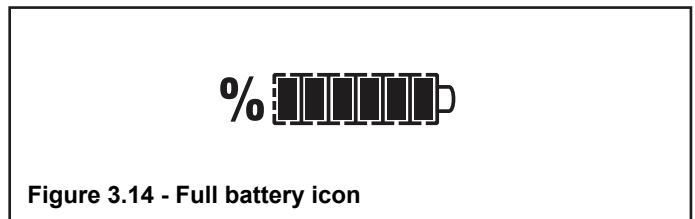

#### 4. Outside Air

**NOTICE:** Use of outside air is required.

**CAUTION!** Outside air control handle may be warm. Allow unit to cool down before closing.

A source of air (oxygen) is required in order for combustion to take place.

1. Before lighting the fire open the bottom access panel by lifting it up and pulling it down.
2. Locate the handle on either the left or right side. Lift the handle up and pull out to open the door (pushing the handle in will close the door).
3. Before closing the bottom access panel, make any adjustments to the convection fan (see step 6).

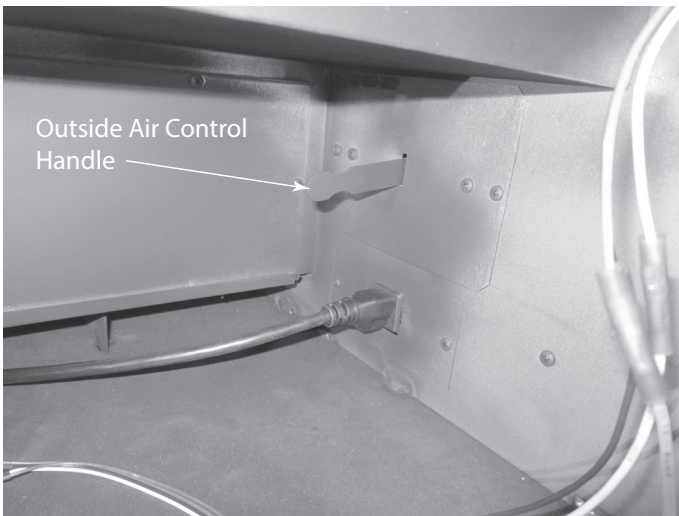

Figure 3.16 Outside Air Control Handle

#### 5. Glass Door

This fireplace has been tested and is intended for use with the door as supplied with this fireplace.

**WARNING! Risk of Fire and Smoke!** Fireplace should be operated only with doors fully open or door fully closed. If the door is left partly open, gas and flame may be drawn out of the fireplace opening.

**WARNING! Fire Risk!**

- Do not use glass door to hold burning material in fireplace.

Glass may break or burning material may roll out.

**WARNING! RISK OF Fire!** Do NOT install and or use any component not approved by Hearth & Home Technologies.

#### 6. Convection Fan Operation

(Located behind the lower access door)

The high fan speed can be decreased by turning the knob counterclockwise. The fan speed will vary automatically based on the temperature of the appliance. The fan can be turned off by manually turning the knob counterclockwise to the off position. See Figure 3.17.

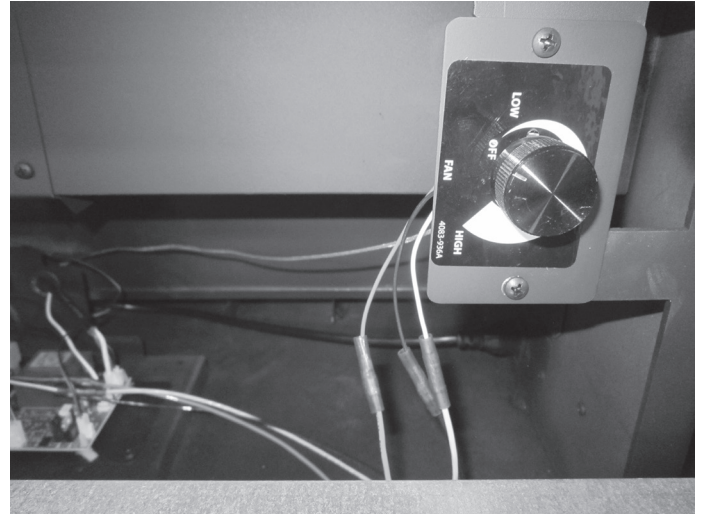

Figure 3.17 Fan Speed Control

#### 7. Battery Holder

The battery holder holds eight (8) D cell batteries and will allow the appliance to operate without 110V. (The fan will not operate on batteries only.)

1. Open the control access door.
2. Remove the control board cover. See Figure 3.18

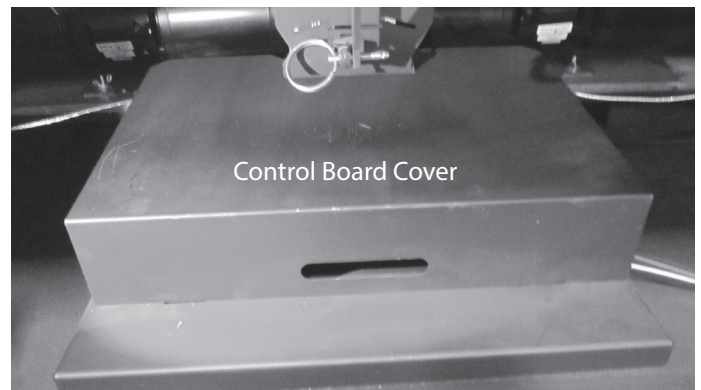

Figure 3.18 Control Board Cover

3. Install the batteries. See Figure 3.19

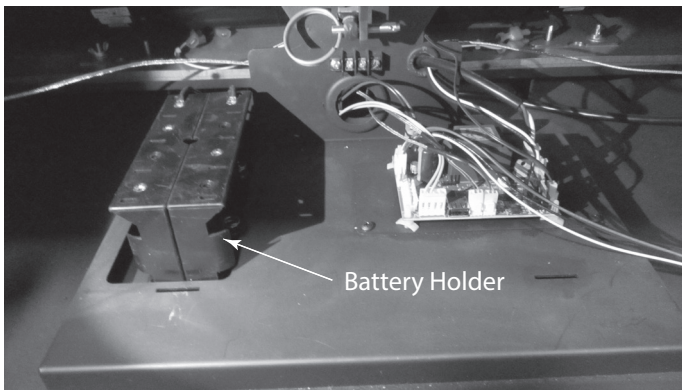

Figure 3.19 Install Batteries

4. Reverse the previous steps.

The batteries will allow the appliance to operate 30 days or more without power.

## C. Fuel

**WARNING! For use with solid wood fuel only.**

*Other fuels may overfire and generate poisonous gases (i.e. carbon monoxide).*

This fireplace is designed to burn natural wood only. Higher efficiencies and lower emissions generally result when burning air dried seasoned hardwoods, as compared to softwoods or to green or freshly cut hardwoods. **DO NOT BURN:**

- Garbage
- Lawn clippings or yard waste
- Materials containing rubber, including tires
- Materials containing plastic
- Waste petroleum products, paints or paint thinners, or asphalt products
- Materials containing asbestos
- Construction or demolition debris
- Railroad ties or pressure-treated wood
- Manure or animal remains
- Salt water driftwood or other previously salt water saturated materials
- Unseasoned wood
- Paper products, cardboard, plywood, or particleboard. The prohibition against burning these materials does not prohibit the use of fire starters made from paper, cardboard, saw dust, wax and similar substances for the purpose of starting a fire in an affected wood heater.

Burning these materials may result in release of toxic fumes or render the heater ineffective and cause smoke.

## 1. Hardwood vs. Softwood

Your fireplace's performance depends on the quality of the firewood you use. One species of wood varies very little to the other in terms of energy content. All seasoned wood contains about 8,000 BTU's per pound. Hardwoods have a greater density than softwoods; a piece of hardwood will contain about 60% more BTU's than an equal size piece of softwood. A cord of seasoned oak (hardwood) would contain about 60% more potential energy than a cord of seasoned pine (softwood).

Most softwoods are coniferous. These are trees with needle-like leaves that stay green all year and carry their seeds exposed in a cone. Examples of coniferous trees are Douglas fir, pine, spruce and cedar. Softwoods, being more porous, require less time to dry, burn faster and are easier to ignite than hardwoods. Hardwoods are deciduous trees, broadleaf trees that lose their leaves in the fall. Their seeds are usually found within a protective pod or enclosure. Some examples of deciduous trees are oak, maple, apple, and birch. However, it should be noted that there are some deciduous trees that are definitely not considered hardwoods such as poplar, aspen and alder. Hardwoods require more time to season, burn slower and are usually harder to ignite than softwoods. Obviously, you will use the type of wood that is most readily available in your area. However, if at all possible the best arrangement is to have a mix of softwood and hardwood. This way you can use the softwood for starting the fire, giving off quick heat to bring the fireplace up to operating temperature. Add the hardwood for slow, even heat and longer burn time.

### **WARNING! Risk of Fire!**

- **DO NOT** burn wet or green wood.
- Wet, unseasoned wood can cause accumulation of creosote.

Soft woods	Hard woods
• Douglas Fir	• Oak
• Pine	• Maple
• Spruce	• Apple
• Cedar	• Birch
• Poplar	
• Aspen	
• Alder	

## 2. Moisture Content

The majority of the problems fireplace owners experience are caused by trying to burn wet, unseasoned wood. Freshly cut wood can be as much water as it is wood, having a moisture content of around 50%. Imagine a wooden bucket that weighs about 8 pounds. Fill it with a gallon of water, put it in the firebox and try to burn it. This sounds ridiculous but that is exactly what you are doing if you burn unseasoned wood. Dead wood lying on the forest floor should be considered wet, and requires full seasoning time. Standing dead wood can be considered to be about two-thirds seasoned, if cut at the dry time of the year.

Burning wet, unseasoned wood will produce less heat output because it requires energy in the form of heat to evaporate the water trapped inside. This is wasted energy that should be used for heating your home. This moisture evaporates in the form of steam which has a cooling effect in your firebox and chimney system. When combined with tar and other organic vapors from burning wood it will form creosote which condenses in the relatively cool firebox and chimney.

Even dry wood contains at least 15% moisture by weight, and should be burned hot enough to keep the chimney hot for as long as it takes to dry the wood out - about one hour. To tell if wood is dry enough to burn, check the ends of the logs. If there are cracks radiating in all directions from the center, it is dry. If your wood sizzles in the fire, even though the surface is dry, it may not be fully cured.

## 3. Seasoning

Seasoned firewood is nothing more than wood that is cut to size, split and air dried to a moisture content of around 20%. The time it takes to season wood varies from around nine months for soft woods to as long as eighteen months for hardwoods. The key to seasoning wood is to be sure it has been split, exposing the wet interior and increasing the surface area of each piece. A tree that was cut down a year ago and not split is likely to have almost as high a moisture content now as it did when it was cut.

To season wood:

- Cut logs to size
- Split to 6 in. (152 mm) or less
- Air dry to a moisture content of around 20%
  - Soft wood - about nine months
  - Hard wood - about eighteen months

**NOTICE:** Seasoning time may vary depending on drying conditions.



## 4. Storing Wood

Splitting wood before it is stored reduces drying time. The following guideline will ensure properly seasoned wood:

- Stack the wood to allow air to circulate freely around and through the woodpile.
- Elevate the woodpile off the ground to allow air circulation underneath.
- The smaller the pieces, the faster the drying process. Any piece over 6 in. (152 mm) in diameter should be split.
- Wood should be stacked so that both ends of each piece are exposed to air, since more drying occurs through the cut ends than the sides. This is true even with wood that has been split.
- Store wood under cover, such as in a shed, or covered with a tarp, plastic, tar paper, sheets of scrap plywood, etc., as uncovered wood can absorb water from rain or snow, delaying the seasoning process. Avoid covering the sides and ends completely. Doing so may trap moisture from the ground and impede air circulation.

## 5. Burning Process

Fire requires fuel, air and heat. If heat is robbed from the fireplace during the drying stage, the new load of wood has reduced the chances for a good clean burn. Always burn dry, seasoned firewood.

### • Kindling or 1st stage:

In this stage, the wood is heated to a temperature high enough to evaporate the moisture which is present in all wood. The wood will reach the boiling point of water (212°F) and will not get any hotter until the water is evaporated. This process takes heat from coals and tends to cool the fireplace.

### • 2nd stage:

The secondary stage is when the wood gives off flammable gases which burn above the fuel with bright flames. It is very important that the flames be maintained and not allowed to go out. This will ensure the cleanest possible fire. You should close down the air to control the point where you can still maintain some flame. If the flames tend to go out, more air is necessary.

### • Final stage:

The final stage of burning is the charcoal stage. This occurs when the flammable gases have been mostly burned and only charcoal remains. This is a naturally clean portion of the burn. The coals burn with hot blue flames.

It is very important to reload your fireplace while enough lively hot coals remain in order to rekindle the next load of wood.

## 6. Dirty Glass

A portion of the combustion air entering the firebox is deflected down over the inside of the door glass. This air flow “washes” the glass, helping to keep smoke from adhering to its surface. When operated at a low burn rate, less air will be flowing over the glass and the smoky, relatively cool condition of a low fire will cause the glass to become coated. Operating the fireplace with the burn rate air control and start-up air control all the way open for 15-20 minutes should remove the built up coating.

## 7. Creosote Formation

When wood is burned slowly, it produces tar and other organic vapors which combine with expelled moisture to form creosote. The creosote vapors condense in the relatively cool chimney flue of a newly-started or a slow-burning fire. As a result, creosote residue accumulates on the flue lining.

When ignited, creosote creates an extremely hot fire which may damage the chimney or even destroy the house.

The chimney shall be inspected at least annually before lighting, or once every two months during heating season.

When creosote has accumulated it shall be removed to reduce the risk of a chimney fire.

## 8. Opacity

Opacity indicates how cleanly your fireplace is burning. Opacity is measured in percent; 100% opacity is when an object is totally obscured by the smoke column from a chimney, and 0% opacity means that no smoke column can be seen. Periodically check the opacity and burn your fireplace as nearly smoke-free as possible (goal of 0% opacity).

## D. First Fire

Before lighting your first fire in the fireplace, make certain that:

- the baffle and ceramic blanket are correctly positioned, resting against the rear support
- firebrick are in place
- all labels have been removed
- all plated surfaces have been cleaned

**NOTICE:** Oils can cause permanent markings on plating if not removed before the first fire.

**NOTICE:** The first three or four fires should be of moderate size to allow the oils and binders to be burned from the fireplace and the refractory and paint to cure. You may notice an industrial odor the first few fires. This is considered normal.

## E. Lighting Instructions/Establish Coal Bed

- Open outside air by opening the lower access panel and locate the outside air handle (it could be on the left or right). Lift the handle up and pull out to open. See Figure 3.20.

Note: This may be closed only when the fireplace is not in use to prevent cold air infiltration.

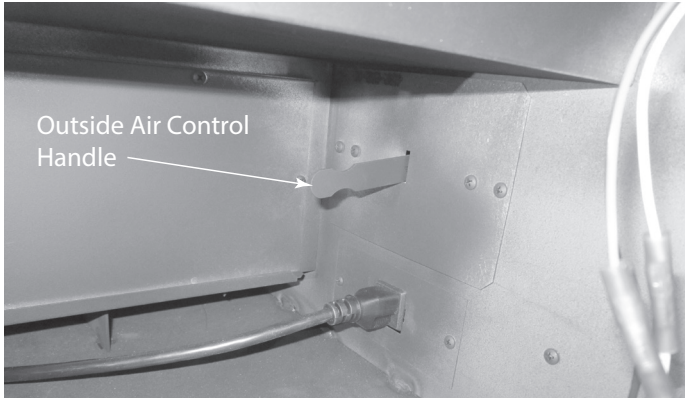

Figure 3.20 Outside Air Handle Shown on Right Side

- Set the thermostat to the desired temperature. Push the SBT button (the air control will open and the light should illuminate green).
- Place several wads (4-5 pieces) of crumpled newspaper on the firebox floor. Add 7-8 lbs. of kindling (pieces of dry cord wood less than 1 inch in diameter) stacked on top of the paper crisscrossed. See Figure 3.21.
- Make sure that no matches or other combustibles are in the immediate area of the fireplace. Be sure the room is adequately ventilated and the flue unobstructed.
- For best results, use a hand held homeowner-type gas torch to light the paper and wood for approximately one minute.
- Leave the door slightly open 1-2 inches (see Figure 3.25)



Figure 3.21 Placing Kindling

- for 2-3 minutes then close the door, latching it lightly. Then push the SBT button. See Figure 3.26.
- After the flame gets established (approximately 5-6 minutes) shut and latch the door. Then push the SBT button. See Figure 3.27.
- When 1/2 to 2/3 of the kindling burns down, open the door, push the SBT button and level the firebox.
- Add 11 to 12 pounds of start-up wood (1-3 inch diameter pieces of cord wood) by stacking them in a crisscross pattern. This will allow for proper air flow.
- Leave door slightly open 1-2 inches (see Figure 3.25) for 1-3 minutes or until a good flame is present. Then close the door, latching it lightly. Then push the SBT button. See Figure 3.26.
- After the flame gets established (approximately 3-5 minutes) shut and latch the door. Then push the SBT button.
- When the kindling has burned down 1/2 to 2/3 and a good flame is still present, push the SBT button and open the door. Level the coal bed insuring that the combustion air holes are not blocked.

### High Burn

- Load 5-6 pieces of cord wood 24 inches long to achieve maximum firebox volume, stack 2 to 3 pieces high in the back first, then 2 to 3 pieces in the front, making sure to work the bottom pieces into the coal bed to insure solid stack once all the wood is loaded. Leave at least a 1 inch gap between the two stacks to insure good air flow around the wood. See Figures 3.22, 3.23 & 3.24 for examples.
- Leave the door slightly open 1-2 inches (see Figure 3.25) for 2 to 3 minutes to get a good flame going then close the door, latching it lightly and push the SBT button. See Figure 3.26.



Figure 3.22 Loading Wood

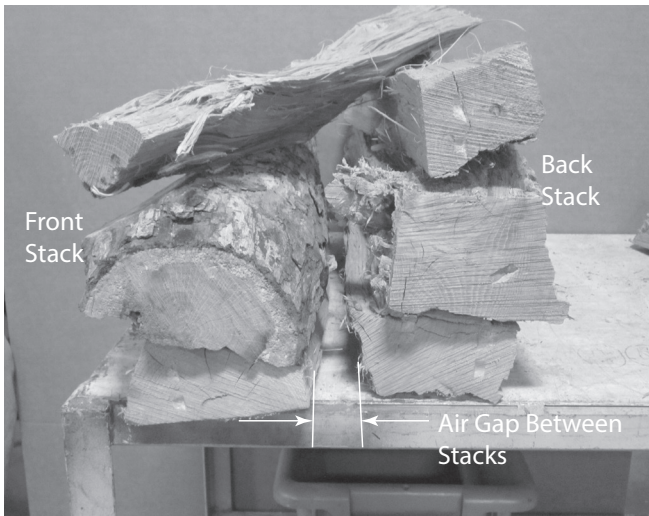

Figure 3.23 Stacking Wood



Figure 3.25 Door Open 1-2 Inches

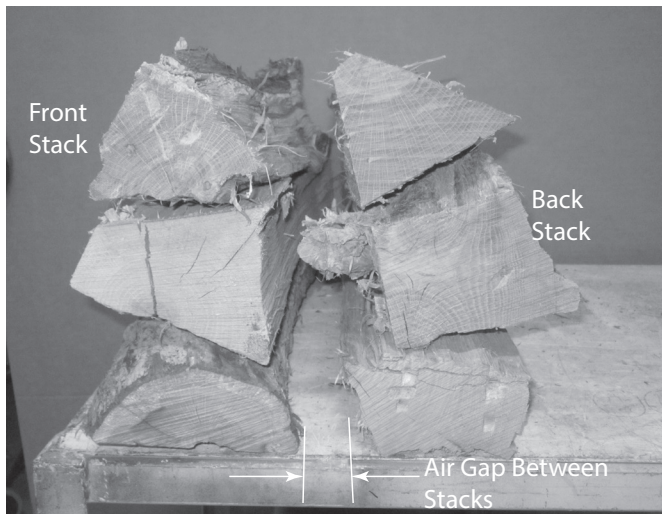

Figure 3.24 Stacking Wood



Figure 3.26 Door Latched Lightly

- After about 5 minutes, close and latch the door completely then push the SBT button again. See Figure 3.27

#### Maximum Heat

Setting the thermostat at a temperature above what the room will achieve, for example, 90° on the thermostat will cause the appliance to burn continuously on high. Press the activation button to activate the system and load fuel.

#### Medium Burn

- When away during daytime hours and unattended set the thermostat to a temperature below what the room temperature will drop to, for example, 45° and then program the thermostat to turn back on to a higher desired temperature (example 75°) after 13 hours. Time will vary depending on house size. Load fireplace by referring to the High Burn section.



Figure 3.27 Door Fully Closed

## Low Burn

- During evenings and overnight, set the thermostat to a temperature below what the room temperature will drop to, for example 45° and then program the thermostat to turn back on to a higher desired temperature (example 75°) after 16-1/2 hours. Time will vary depending on house size. Load fireplace by referring to the High Burn section.

## Reloading the Appliance

- If the light is red or the appliance needs more fuel, push the button, open the door slowly, stir up the coals, load the wood and shut the door.
- When the activation button is pushed, regardless of the temperature set on the thermostat, the appliance will burn on high and go through the high burn cycle until the appliance has warmed up and reached the maximum operating temperature. If the thermostat is not calling for heat, the appliance will progress to low burn setting and continue burning at that rate until the thermostat calls for heat (the room temperature is less than the thermostat is set for).

## F. Heat Output Control

The Pioneer III is designed to operate with a programmable wall thermostat. Set the desired room temperature on the thermostat and the appliance heat output will adjust as necessary to maintain the room temperature.

### **WARNING! Risk of Fire!**

*This wood appliance has manufacturer-set minimum low burn rate that must not be altered. It is against federal regulations to alter this setting or otherwise operate this wood appliance in a manner inconsistent with operating instructions in this manual.*

## G. Manual Override of Air Control

The appliance can be operated manually if necessary when electricity or batteries are not available. It is necessary to remove the front actuator pin and manually control the Air Control located inside the bottom access panel.

### **CAUTION**

The Air Control may become HOT to touch. Use gloves or tool to adjust.

1. Open the Control Access Door
2. Remove the front Actuator Pin by grasping the ring and pulling sideways
3. The Air Control will move freely forward and backward
4. Pushing the Air Control towards the back of the appliance is high
5. Pulling the Air Control towards the front will reduce the burn rate.

The Actuator Pin should be installed when the electricity or batteries have been restored.

1. Align the hole in the Air Control with the hole in the Actuator
2. Insert the Actuator Pin

***WARNING! Risk of Fire!*** Keep combustible materials, gasoline and other flammable vapors and liquids clear of the fireplace.

### **DO NOT:**

- store flammable materials close to the fireplace
- use gasoline, lantern fuel, kerosene, charcoal lighter fluid or similar liquids to start or "freshen up" a fire in this fireplace. The results can be fatal.

*Keep all flammable liquids well away from the fireplace while it is in use. Combustible materials may ignite.*

## H. Frequently Asked Questions

ISSUES	SOLUTIONS
Odor from appliance	When first operated, this appliance may release an odor for the first several hours. This is caused by the curing of the paint and the burning off of any oils remaining from manufacturing.
Metallic noise	Noise is caused by metal expanding and contracting as it heats up and cools down, similar to the sound produced by a furnace or heating duct. This noise does not affect the operation or longevity of the appliance.
Whirring sound	The fan produces a whirring sound which increases in volume as the speed is increased.

**CONTACT YOUR DEALER** for additional information regarding operation and troubleshooting.  
Visit [www.quadrafire.com](http://www.quadrafire.com) to find a dealer.

### **WARNING**

DO NOT PLACE COMBUSTIBLE OBJECTS IN FRONT OF THE APPLIANCE. High temperatures may ignite clothing, furniture or draperies.

### **WARNING**



**Fire Risk.**

- DO NOT BURN GARBAGE OR FLAMMABLE FLUIDS SUCH AS GASOLINE, NAPHTHA OR ENGINE OIL.
  - Do NOT burn treated wood or wood with salt (driftwood).
  - May generate carbon monoxide if burn material other than wood.
- May result in illness or possible death.

### **WARNING**



**Fire Risk.**

Keep combustible materials, gasoline and other flammable vapors and liquids clear of appliance.

- Do NOT store flammable materials in the appliance's vicinity.
- DO NOT USE GASOLINE, LANTERN FUEL, KEROSENE, CHARCOAL LIGHTER FLUID OR SIMILAR LIQUIDS TO START OR "FRESHEN UP" A FIRE IN THIS HEATER.
- Keep all such liquids well away from the heater while it is in use.
- Combustible materials may ignite.

## I. Quick Start Guide

**TURN YOUR THERMOSTAT ON  
\*\*PROGRAM YOUR THERMOSTAT**



**1**

**PUSH SMART BURN  
TECHNOLOGY (SBT)  
ACTIVATION BUTTON**

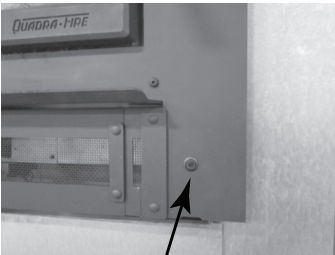

**LOWER RIGHT CORNER  
OF FACE**

**2**

**LOAD PAPER & KINDLING ON  
TOP AND LIGHT**



**3**

**\*LEAVE DOOR AJAR UNTIL  
FIRE IS ESTABLISHED**



**4**

**PUSH SBT BUTTON, ADD  
MORE WOOD, CLOSE AND  
LATCH DOOR**

**5**

\*\*Refer to Owner's Manual or use and care video on how to program

\*Starting a fire may not require an open door for draft.

### LED Operation

Light	What To Do
Green	Everything OK; air control is fully open.
None	Everything OK; push button when reloading fuel.
Red	Calling for heat, push button and load fuel.
2 fast red blinks then no color for 1 second	Left thermocouple error, call your dealer.
3 fast red blinks then no color for 1 second	Right thermocouple error, call your dealer.
1 red blink every 1/2 second continually	Overfire indication; do not load fuel. Call your dealer.

### WARNING! RISK OF FIRE

Close and securely latch the door after the fire has started, and after refueling, to prevent:

- Spillage of smoke, flame and carbon monoxide
- Spillage of sparks, coals and logs
- Over-firing

DO NOT leave the appliance unattended with the door open.

# 4 Maintenance and Service

This fireplace needs periodic inspection and repair for proper operation. It is against federal regulations to operate this fireplace in a manner inconsistent with operating instructions in this manual.

## **WARNING! Hot Surfaces!**

*Glass and other surfaces are hot during operation AND cool down. DO NOT clean fireplace until it is cooled.*

Task	Frequency	To be completed by
1. Chimney Inspection	As needed	Homeowner or Chimney Sweep
2. Chimney Cleaning	As needed	Chimney Sweep
3. Plated Surfaces Cleaning	As needed	Homeowner
4. Glass Door	Seasonally	
5. Glass Cleaning	As needed	
6. Door Gasket	Seasonally	
7. Ash Removal	As needed	
8. Baffle/Blanket/Channel Protector	Seasonally	
9. Firebrick	Seasonally	

## **A. Maintenance Tasks-Homeowners**

Installation and repair should be done by a qualified service technician only. The fireplace should be inspected before use and at least annually by a professional service person.

The following tasks may be performed annually by the homeowner. If you are uncomfortable performing any of the listed tasks, please call your dealer for a service appointment.

### **1. Chimney Inspection**

**Frequency:** As necessary; at least annually before lighting fireplace, or once every two months during heating season.

**By:** Homeowner/Chimney Sweep

- Confirm that termination cap remains clear and unobstructed.
- Inspect for blockages such as bird nests, leaves, etc.
- Inspect for corrosion or separation.
- Inspect for creosote and remove as needed, at least every two months during the heating season.
- Inspect the system at the fireplace connection and at the chimney top.

In the event of a chimney fire, Hearth & Home Technologies recommends replacement of the chimney and inspection of the adjacent structure to the provisions of NFPA Level III inspection criteria.

**WARNING! Risk of Asphyxiation and Fire! Annual inspection by qualified technician recommended.**

*Check:*

- *condition of door, surrounds and fronts*
- *condition of glass and glass assembly*
- *obstructions of combustion and ventilation air*
- *obstructions of termination cap*

*Clean:*

- *glass*
- *air passageways, grilles*

## 2. Creosote (Chimney) Cleaning

**Frequency:** As needed; at least annually before lighting, or once every two months during heating season. When creosote has accumulated it shall be removed to reduce the risk of a chimney fire.

**By:** Chimney Sweep

**Tools Needed:** Brush, Phillips screwdriver

- When wood is burned slowly, it produces tar and other organic vapors, which combine with expelled moisture to form creosote. The creosote vapors condense in the relatively cool chimney flue of a slow-burning fire. As a result, creosote residue accumulates on the flue lining. When ignited, this creosote makes an extremely hot fire.
- Remove all ash from the firebox and extinguish all hot embers before disposal. Allow the fireplace to cool completely.
- Remove baffle and ceramic blanket from fireplace before cleaning chimney (refer to Section 5.C.3 Baffle Removal and Installation).
- Close the door tightly.
- Remove the top of the termination cap as shown in Figure 4.1 to clean the cap and chimney.
- The creosote or soot should be removed from the chimney with a brush specifically designed for the size of chimney in use.
- Reinstall termination cap.
- Clean out fallen debris from the firebox.
- Replace baffle and ceramic blanket.

**WARNING! Risk of Fire! Ignited creosote is extremely HOT. Prevent creosote buildup.**

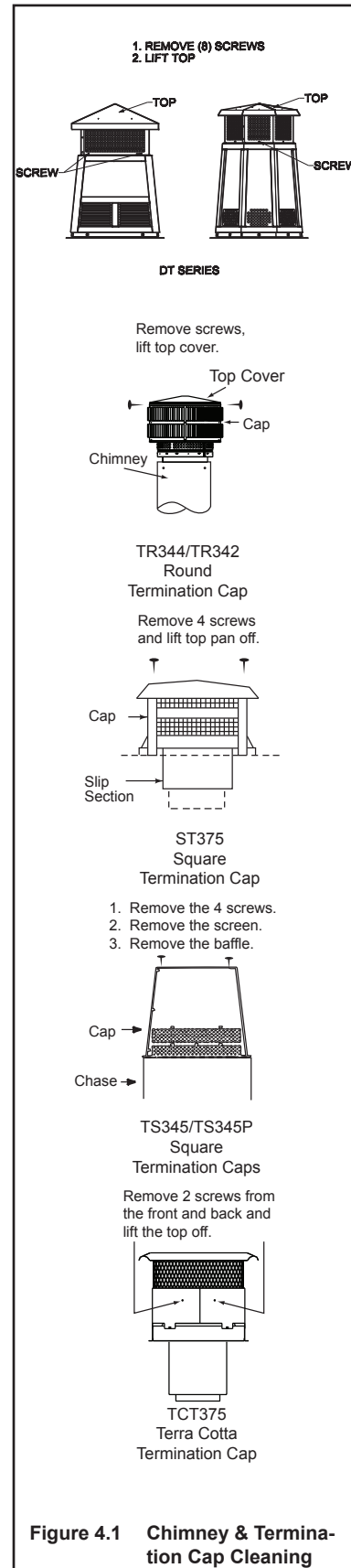



### 3. Care and Cleaning of Plated Surfaces

**Frequency:** Initially and as needed

**By:** Homeowner

**Tools Needed:** Vinegar or glass cleaner, soft towel

**CAUTION!** Do not use a polish with abrasives. It will scratch plated surfaces.

- Use a glass cleaner or vinegar and towel to remove the oils.
- Oils can cause permanent markings on plating if not removed.
- After plating is cured, oils will not affect the finish.

### 4. Glass Door

**Frequency:** As necessary

**By:** Homeowner

- Inspect glass panel for cracks. Replace if this condition is present.
- Inspect glass gasket. Confirm glass does not move around in glass frame.

### 5. Glass Cleaning

**Frequency:** As necessary

**By:** Homeowner

**Tools Needed:** Vinegar or glass cleaner, soft towel

- Clean glass with a non-abrasive glass cleaner. Use a damp cloth dipped in wood ashes or a commercially available oven cleaner. Remove any oven cleaner residue with a glass cleaner or soap and water.

### 6. Door Gasket

**Frequency:** Seasonally

**By:** Homeowner

- Open door, place half a dollar bill inside and close the door.
- Attempt to pull the bill out.
- If the bill gives good resistance or is not removable, the gasket is adjusted correctly. If the bill is easily removed, the gasket needs adjustment or replacement to create an even seal all around door.

It may be necessary to adjust or tighten the door latch.

### 7. Ash Removal

**Frequency:** As necessary

**By:** Homeowner

**Tools Needed:** Covered metal container, metal shovel, fireplace broom

**WARNING! Risk of Fire! DO NOT** remove ashes until the fire is out and the fireplace is cold.

- Ashes should be placed in metal container with tight fitting lid.
- The closed container of ashes should be placed on a noncombustible floor or on the ground, well away from all combustible materials, pending final disposal.
- If the ashes are disposed of by burial in soil or otherwise locally dispersed, they should be retained in the closed container until all cinders have thoroughly cooled.

### 8. Baffle and Blanket

**Frequency:** As necessary

**By:** Homeowner

**Tools Needed:**

- Ensure correct baffle and baffle protection channel placement; replace baffle components if damaged or missing.
- The ceramic blanket and baffle board **MUST** be in contact with the back of the firebox and even with each other in the front. The baffle protection channel **MUST** be in position. Refer to Section 3.A.3.

### 9. Firebrick

**Frequency:**

**By:**

**Tools Needed:**

- Inspect condition of brick. Replace if crumbly or otherwise deteriorated, or if cracks exceed 1/4 in. (6 mm).

## B. Replacement Maintenance

### 1. Glass Replacement

- Ensure that the fire is out and the fireplace is cool to the touch.
- Protect a table or counter top with padding or towels.
- Open the door and while supporting it, remove the (2) top hinge screws and retainer, lift door up and off.
- Lay door face down on table or counter making sure handle and handle attachment knob hang over the edge of the table top so door lays flat on the soft surface.
- Remove screws from the top and bottom glass frame (12 screws) using a #2 Phillips Head screwdriver. Set frame aside and retain screws.  
**HINT:** Soak screws in penetrating oil for easy removal.
- Remove the glass and discard.
- Position the new glass with gasket into the door.
- Replace the glass frames.
- Start screws to secure glass frame to door, keeping them loose for adjusting the glass. Then continue to tighten each screw alternately, a few turns at a time, until the glass panel is tightened snugly. **DO NOT OVERTIGHTEN OR CROSS THREAD SCREWS.**
- Replace the door on the fireplace.
- After the first burn, recheck the tightness of the screws.

**NOTICE:** Remove all labels from glass before lighting the first fire in your fireplace.

### CAUTION!

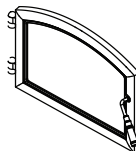

Handle glass assembly with care.

#### When cleaning glass:

- Avoid striking, scratching or slamming glass.
- Do NOT clean glass when hot.
- Do NOT use abrasive cleaners.
- Use a hard water deposit glass cleaner on white film.
- **Refer to maintenance instructions.**



### WARNING



#### Injury Risk.

- Use only glass specified in manual.
- **DO NOT REPLACE** with any other material.

### 2. Tighten or Adjust Door Latch

Remove the lock nut holding latch cam and one or two spacing washers on the door as shown in Figure 4.2. Reinstall the cam and tighten locknut.

OR

Replace the gasket material. Wear or damage to the gasket material can cause air leakage into the firebox resulting in overfiring and loss of efficiency.

A replacement gasket is available from your dealer.

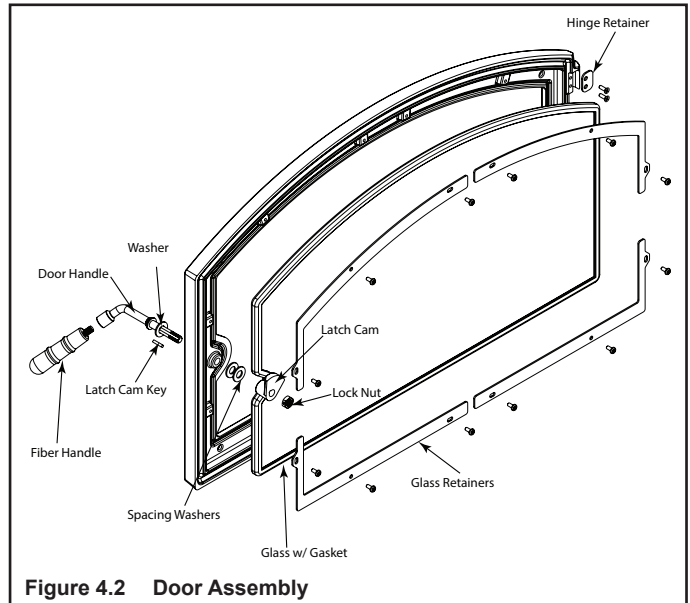

Figure 4.2 Door Assembly

### 3. Manifold Tubes Removal and Replacement

- Remove all ash from the firebox disposing of it in a metal container.
- The manifold tubes are located in the upper portion of the inside of the firebox.
- Each tube is attached with one 3/16" stainless steel hex head screw attached to the firebox on the left hand side. The right hand side of the tube just slides into a hole.
- Please note that each tube is different in regards to the air holes or mounting holes.
- Remove the hex head screw and clip. Slide the tube to the right, angle down and pull out. It is recommended to replace one tube at a time to insure correct placement.

#### 4. Door Handle Assembly

- Slide door handle through door.
- Install washer(s) as shown in Figure 4.3.
- Install key groove.
- Align groove in latch cam with key; slide latch cam over shaft.
- Install locknut but do not overtighten, the handle needs to move smoothly.
- Install fiber handle using a clockwise motion until the fiber handle is snug against the door handle shaft.

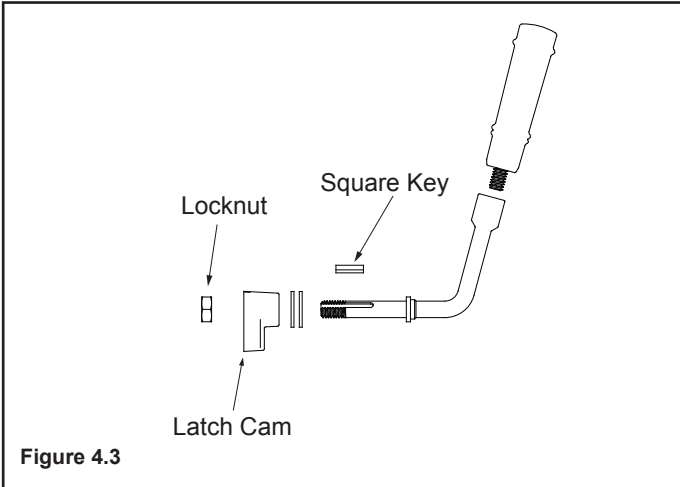

Figure 4.3

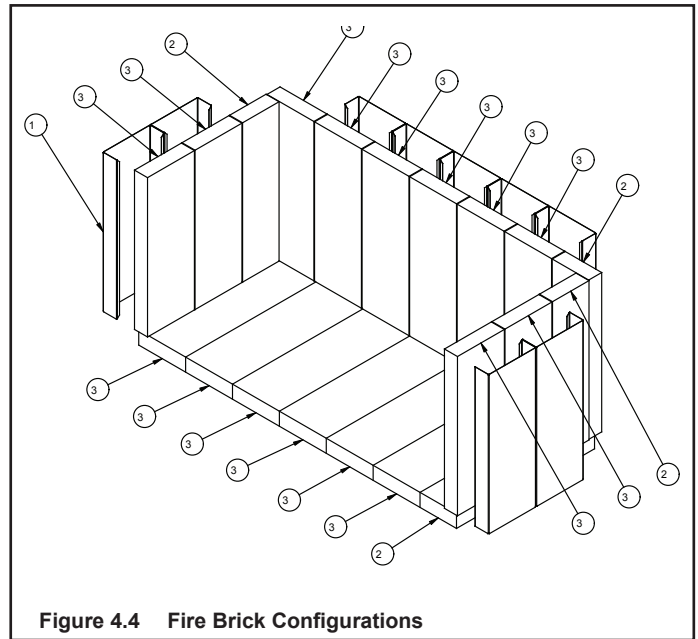

Figure 4.4 Fire Brick Configurations

#	Brick Size	Qty. in Set
1	Brick Wrap	9
2	Firebrick 13.25 x 3.50 x 1.25	4
3	Firebrick 13.25 x 4.50 x 1.25	16

#### 5. Firebrick Replacement

The firebox of your fireplace is lined with high quality firebrick and refractory board under the bottom firebrick only, which has exceptional insulating properties. There is no need to use a grate; simply build a fire on the firebox floor. Do not operate the fireplace without bricks.

**IMPORTANT:** The bricks are very similar in size. Be certain you have the proper brick in the correct location. Measure the brick size for accuracy.

After the coals are completely cooled, remove all old firebrick and ash from unit and vacuum out firebox.

- Remove new brick set from box and lay out to diagram shown in Figure 4.4.
- If the bottom refractory board needs replacing, do so at this time.
- Lay bottom bricks in unit.
- Install rear bricks on the top of the bottom bricks. Slide top of bricks under clip on back of firebox wall and push bottom of brick back.
- Install side bricks. Slide top of brick under clips on side of firebox and push the bottom of the brick until it is flush with the side of the unit.

## 6. Thermocouple Replacement

- To replace a thermocouple, ensure the appliance is completely cool.
- Shut off power to the appliance or unplug the control board from the junction box.
- Remove the dust cover by lifting up and pulling out to expose the control board.
- Remove the thermocouple wire that needs replacing from the control board by pulling up on it and feeding it back through the grommet. See Figure 4.5.

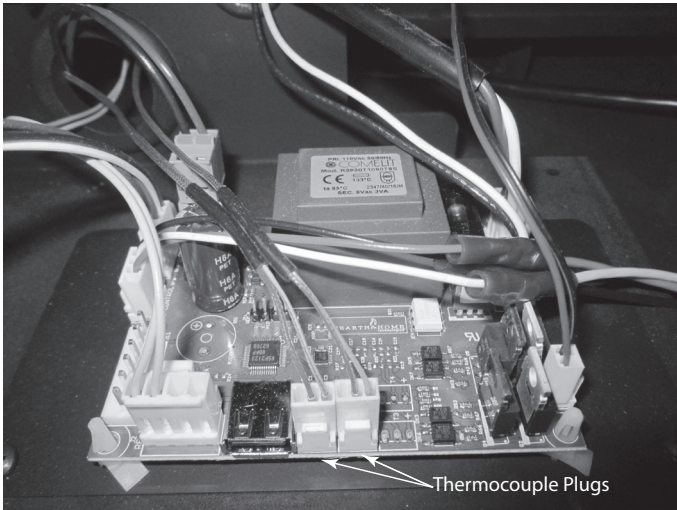

Figure 4.5 Control Board

- Next, open the appliance door, look for the thermocouple in the top left or top right side of the firebox. Once located, remove the stainless steel thermocouple guard by removing the (2) 1/4" bolts using a 3/8" nut driver. See Figure 4.6.

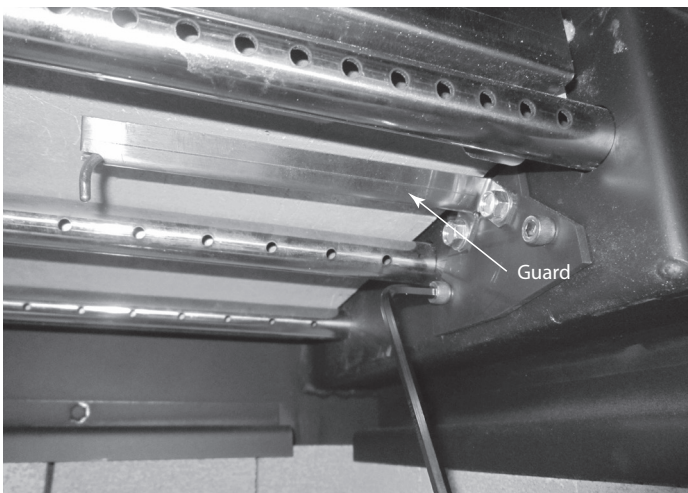

Figure 4.6 Thermocouple Guard

- Using a 3/16" Allen wrench, remove the cover plate and slide it off the thermocouple. See Figure 4.7.

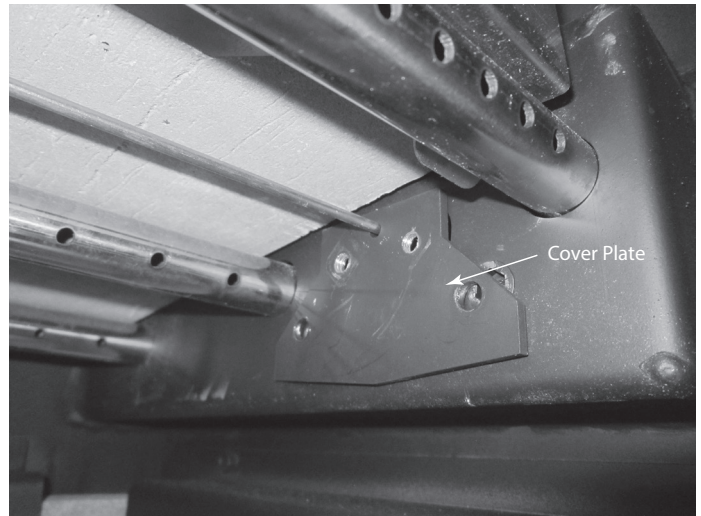

Figure 4.7 Remove Cover Plate

- Using a long 3/8" nut driver, remove the (2) bolts in through the hole holding the thermocouple on. See Figure 4.8.

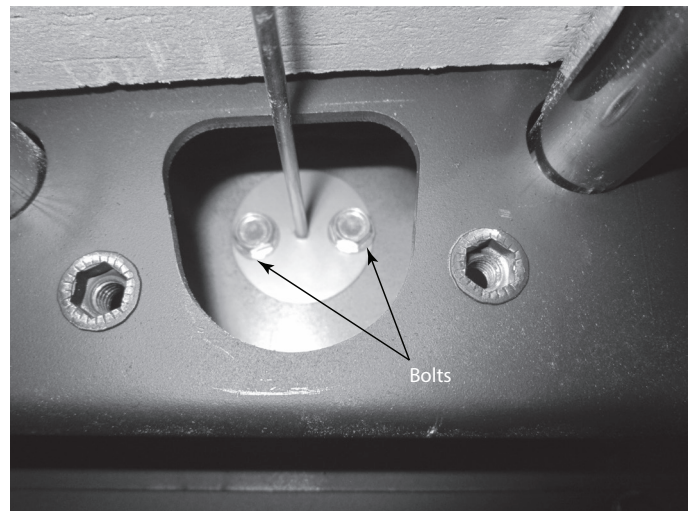

Figure 4.8 Remove Bolts

- Pull the thermocouple wire up and out of the hole while feeding the wire up from the bottom.
- Install the new thermocouple by feeding the end with the plug on it down through the hole and out through the bottom opening.
- Secure the thermocouple to the appliance and reinstall the cover plate and thermocouple guard. Connect the wires to the control board and the dust cover.

## 7. Baffle Removal and Installation

### **WARNING! Hot Surfaces!**

Glass and other surfaces are hot during operation AND cool down. **DO NOT** clean fireplace until it is cooled.

- Remove all ash from firebox and place into a metal container.
- Remove the baffle protection channel by lifting it up and turning it down and pulling it out of the firebox. See Figure 4.9.

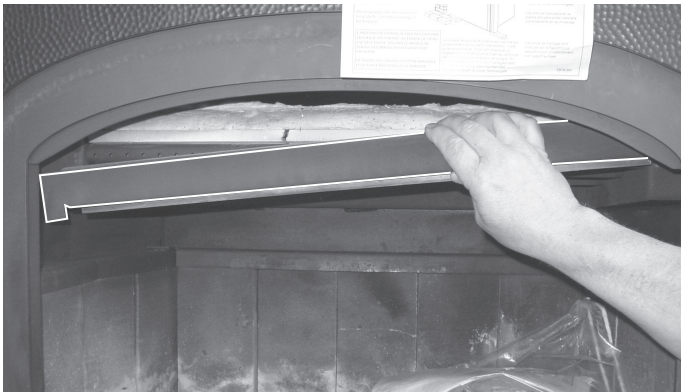

Figure 4.9 Removing Baffle Protection Channel



Figure 4.10 Baffle Board Locations

- The baffle board is in two pieces. Pull one piece at a time forward, tilting it down and out. See Figure 4.9.
- Remove the other piece the same way.
- If replacing the ceramic blanket, pull it forward/down and out.
- Reinstall the ceramic blanket up and over the manifold tubes, making sure it is laying flat and pushed back.
- Reinstall the baffle boards and the baffle protection channel. See Figures 4.11 and 4.12.

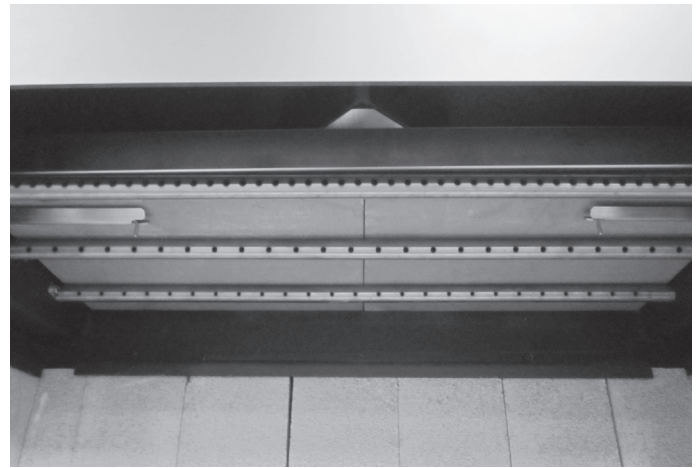

Figure 4.11 Reinstall Baffle Boards

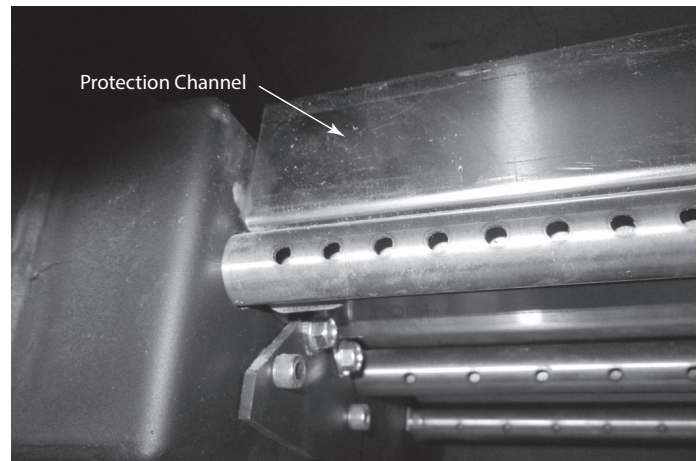

Figure 4.12 Reinstall Baffle Protection Channel

## 8. Fan Replacement

**CAUTION! Risk of Shock! Disconnect power by turning off circuit breaker before servicing or unplugging control board from junction box in behind the access panel..**

The Fireplace comes equipped with two fans, installed at the factory with electric access on both sides of the fireplace.

### • Fan Replacement Instructions

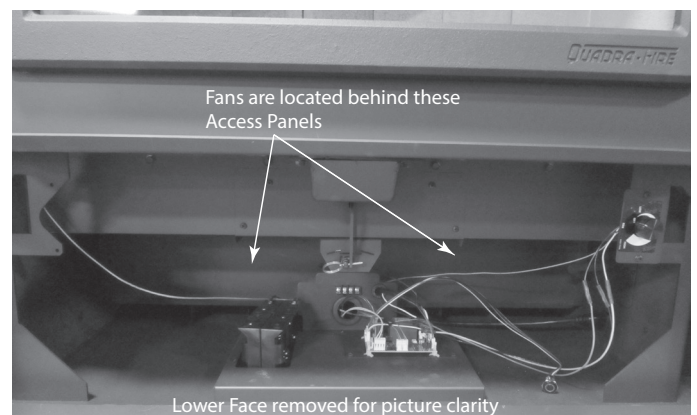

Figure 4.13 Fan Locations

- Open the bottom access panel and remove it by pulling out on one of the spring hinges.
- Lift the control cover up and out to expose the control board. See Figure 4.14.

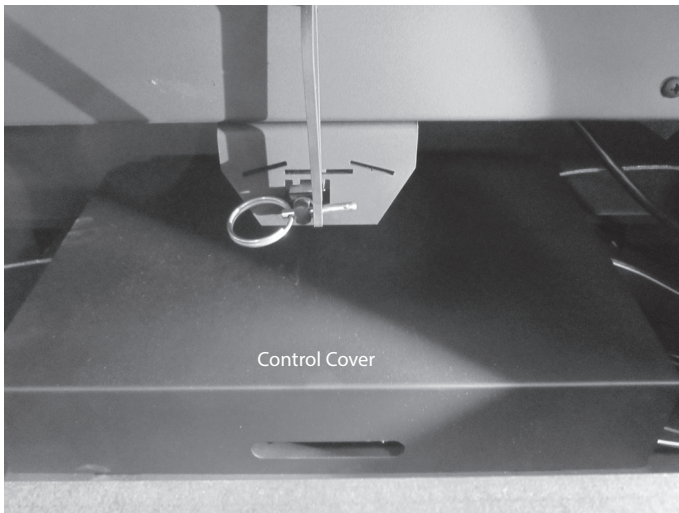

Figure 4.14 Remove Control Cover

- Unplug the thermocouple wires from the control board. See Figure 4.15.

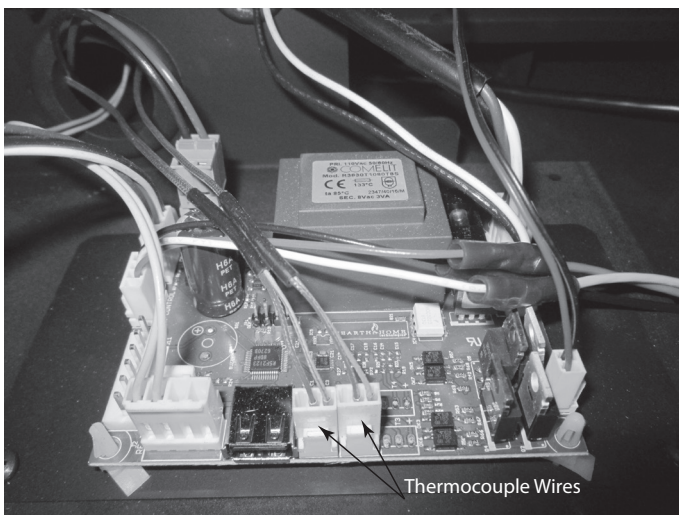

Figure 4.15 Unplug Thermocouple Wires

- Remove the (4) screws from each fan access panel and pull them forward and out. See Figure 4.16.

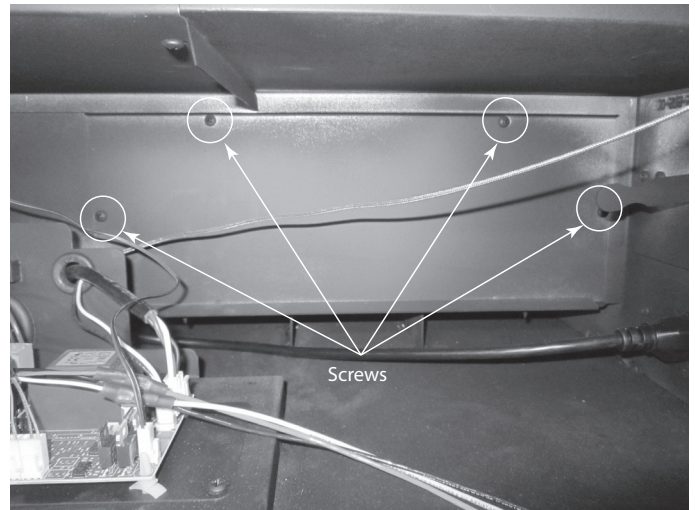

Figure 4.16 Remove Screws From Access Panel

- Disconnect the wires from the fans. See Figure 4.17.

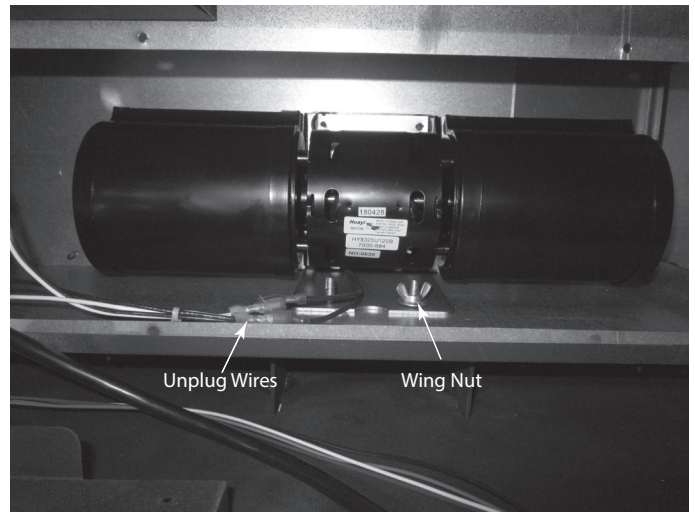

Figure 4.17 Disconnect Wires from Fans

- Remove the wing nuts that lock the fans down.
- Life the fans up to clear the bolts and fish them around and out the front.
- Reinstall in the reverse order.

# 5 Troubleshooting

## A. FAQs

Hearth & Home Technologies assumes no responsibility for the improper performance of the fireplace system caused by inadequate draft due to environmental conditions, down drafts, tight sealing construction of the structure, or mechanical exhausting devices which will create a negative air pressure within the structure where the fireplace is located.

If smoke spillage occurs from a fireplace opening when the door is open, there is either a leakage in the flue, a blockage in the flue, or some condition is affecting draft. Understanding and differentiating the conditions which can cause each of these kinds of spillage problems is essential to their solution.

- **Flue Leakage**  
Check for improperly connected flue joints or a damaged flue joint in the chimney system. Such leakage would reduce draft (air would be drawn in through the leaks rather than through the fireplace). The result might be difficult start-up and smoky fires that might spill if other adverse draft conditions accompany this problem.
- **Flue Blockage**  
The damper should be open.  
Check for objects that may have fallen down the chimney.

Flue draft is measured as negative pressure in the chimney. The amount of negative pressure determines how strong the draft is. The draft is important because it draws the combustion air into the fireplace and pulls the smoke out of the chimney.

There are three basic criteria essential in establishing and maintaining flue draft:

- availability of combustion air
- heat generated from the fire
- diameter and height of the flue system

These three factors work together as a system to create the flue draft. Increasing or decreasing any one of them will affect the other two and thus change the amount of draft in the entire system.

If the fire is hard to start and smoke spills out of the fireplace, or you find it difficult to establish and maintain a moderately high burn rate, then the flue draft is too low and corrective measures must be taken.

Be sure you have air available for combustion and that your firewood is dry and well seasoned. Build your fires properly and according to the instructions given in op-

erating instructions, "Starting a Fire". Be sure your flue system is installed correctly and that it is the proper diameter and height. Check for the following:

- All chimney sections are properly installed.
- The chimney is clean and free of creosote or soot buildup.
- Make sure overhanging trees and branches are cut back within ten feet of the top of the chimney and the chimney is free of debris from animals.
- Ensure the chimney cap is clean and free of any buildup of soot or creosote if cap is equipped with a spark arrestor screen.
- Be sure the ceramic blanket (above the baffle) and the baffle are in their proper positions
- The wood being used is dry and well seasoned.

If you still suspect you have a low draft problem it may be necessary to increase the volume of air in your flue system. Since the diameter of your flue system is matched with the size of the flue collar and should not be changed, then the height of the system must be increased. Add chimney sections one at a time until the draft improves.

In some cases, regardless of what you do, it can still be difficult to establish the proper flue draft. This is especially evident when using an exterior factory-built chimney or exterior masonry chimney. Try holding a burning rolled up newspaper as close to the flue outlet as possible for a few minutes, then light the paper under the kindling. The heat generated from the burning rolled up newspaper should help get the draft established.

Still other factors can affect how well your flue system performs. Neighboring structures, high winds, tall trees, even hillsides can affect air currents around the chimney. Well designed chimney caps are available that can help. Your fireplace dealer is the local expert in your area. He can usually make suggestions or discover problems that can be easily corrected allowing your fireplace to operate correctly as it has been designed, providing safe and economical heat for your home.

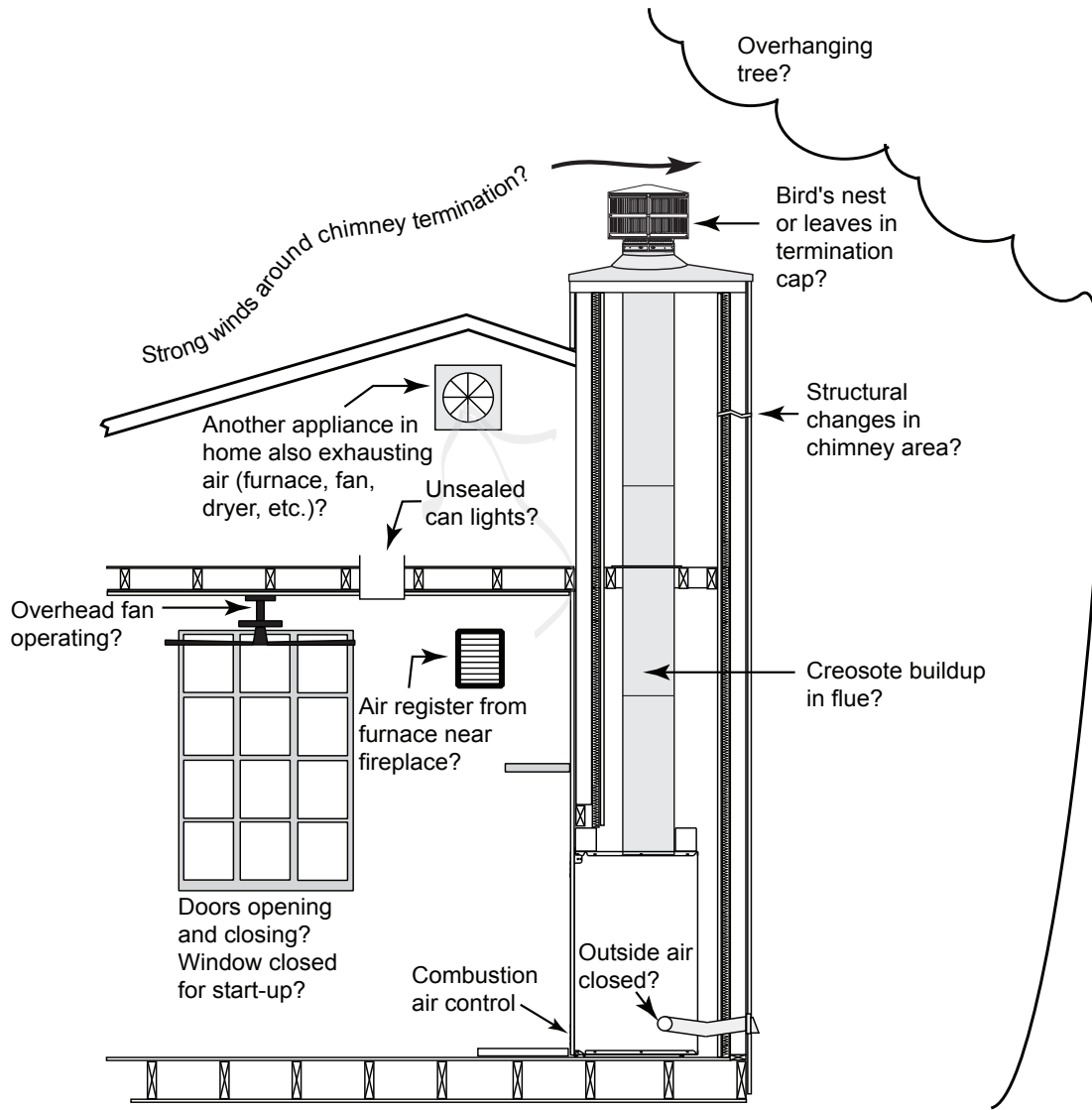

Figure 5.1 Factory-built Fireplaces: Troubleshooting



## B. Troubleshooting Table

With proper installation, operation, and maintenance your wood burning appliance will provide years of trouble-free service. If you do experience a problem, this troubleshooting guide will assist you or a qualified service person in the diagnosis of a problem and the corrective action to be taken.

Start Fire Problems	Possible Cause	Solution
Can not get fire started Excessive smoke or spillage Burns too slowly Not enough heat output	Not enough kindling/paper or no kindling/paper	Use dry kindling, more paper. Arrange kindling & wood for air movement.
	Not enough air for fire to ignite	Check for restricted termination cap
		Check for blockage of outside air kit (if installed).
		Check for flue blockage.
		Pre-warm flue before starting fire (refer to Building a Fire Section).
		Check for adequate vent height.
		Open window below the appliance towards the wind.
	Wood condition is too wet, too large	Use dry, seasoned wood (refer to Seasoned Wood Section).
	Bed of coals not established before adding wood	Start with paper & kindling to establish bed of coals (refer to Building a Fire Section).
	Flue blockage such as birds' nests or leaves in termination cap	Have chimney and cap inspected and cleaned by a certified chimney sweep.
	Down draft or negative pressure Competition with exhaust devices	Do not use exhaust fans during start-up.
		Open window below the appliance towards the wind.
	Activation button not pressed when starting fire	Press activation button and ensure that the indicator light turns solid green.
	Actuator on air control did not move to full open position	In all cases the air control will move to the full open position after pressing the activation button. A visual check of this may be in order or follow the field diagnostics guide.
Blinking red light indicated on activation button	This is indicating a fault of a component in the appliance. Refer to the diagnostics guide to analyze the blinking and to diagnose further. Do not operate appliance.	
No AC power to appliance	Check breaker box and ensure both ends of the power cord are plugged in underneath.	
Low Batteries or NO batteries placed in battery backup appliance	Low voltage of the battery pack or lack of batteries in the backup battery pack will not allow operation of system if regular AC power is not available. Replace batteries.	
Air control disconnected from actuator due to previous disconnecting	If the air control was disconnected due to no regular AC power/ no batteries or low battery voltage condition then it will be necessary to reattach the air control to the actuator.	

## Troubleshooting Guide con't

Fire burns too fast or room temperature is overshooting the set point of the thermostat	Extremely dry or soft wood	Mix in hardwood.
		Mix in less seasoned wood after fire is established (refer to Wood Fuel Section).
	Overdrafting	Check for correct vent height; too much vertical height creates overdrafting.
		Check location of vent termination (refer to Chimney Termination Requirement Section).
	Thermostat is not operational or is programmed incorrectly.	Refer to specific instructions for thermostat used for proper programming method. Refer to field diagnostics to ensure that signal from thermostat is being interpreted by circuit board correctly.
	Too much fuel was loaded into appliance when reloaded.	Proper amounts of fuel must be loaded based on specific home conditions and exterior weather conditions.
	Air control is not closing to reduce burn rate.	This could be related to any of the conditions found above. Refer to the field diagnostics to perform some testing.
	Thermocouples in appliance are no longer in proper position.	The thermocouples that sense the condition of the fire in the appliance must be in the proper location. A hit from loading fuel or other event may have caused them to bend excessively. In a cool appliance they can be bent back into proper position.
Thermocouple failure.	This will be indicated by a blinking light on the activation button. Refer to diagnostics.	
Fan not operating properly	Fan not turning on when appliance is hot.	Check that the rotational position of the power level knob is on a selected power level rather than off.
		Check that the fan wire is plugged into the control board underneath.
		Check that the fan is plugged into the back of the appliance.
Fan is running at maximum setting all the time.	This could indicate a failure of the thermocouples in the appliance. This condition will also be indicated by a blinking light on the activation button. Refer to diagnostics.	
Glass doesn't stay clean	Burning on low, wet wood	Establish a good hot fire. Use well-seasoned wood.

## Diagnostics

Indication	Item	Fault Implication while in use to homeowner
Green Light	Activation button has been pushed.	Appliance is ready for a new fire or reload.
No Light	Thermostat is not calling for heat	Appliance is in shutdown mode.
Red Light	Appliance call for heat	Appliance is in charcoal phase and thermostat calling for heat. Time to reload.
Two blinks flashes of red light then long off (1 sec)	Left Thermocouple burned out (open circuit)	Appliance will exhibit either late or premature shutdowns. Could lead to snuffing of the fire if shutdown too quickly or too much heat when commanded to shutdown.
Three fast blinks of red light then long off (1 sec)	Right Thermocouple burned out (open circuit)	Appliance will exhibit either late or premature shutdowns. Could lead to snuffing of the fire if shutdown too quickly or too much heat when commanded to shutdown.
.5 second on and .5 off of red light	Overfire Indication	The appliance air control is 'stuck' open if we are seeing temps over the safety limit for 30 minutes. Stuck due to a jammed air control or a faulty linear actuator. Not much the controller can do other than alert the homeowner with the status light because it may have happened while homeowner was away.

# 6 Reference Materials

## A. Service Parts

**QUADRA-FIRE** Service Parts

Woodburning Fireplace

**PIONEER-III-BK**

Beginning Manufacturing Date: Dec 2018  
Ending Manufacturing Date: Active

PIONEER-III-ABK - Arch Door

PIONEER-III-RBK - Rectangle Door

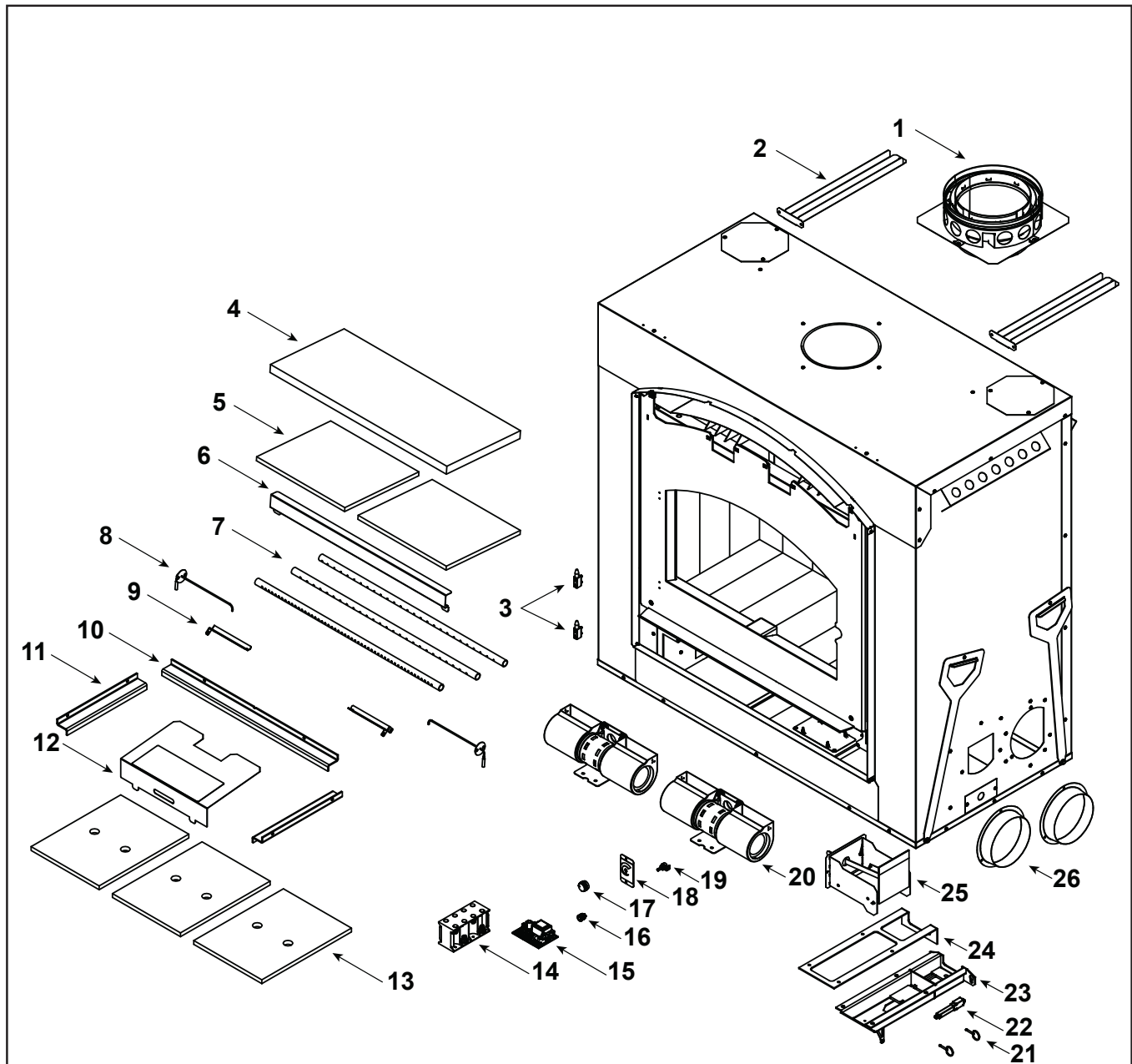

Part number list on following page.

Beginning Manufacturing Date: Dec 2018  
Ending Manufacturing Date: Active

IMPORTANT: THIS IS DATED INFORMATION. Parts must be ordered from a dealer or distributor. **Hearth and Home Technologies does not sell directly to consumers.** Provide model number and serial number when requesting service parts from your dealer or distributor.



**Stocked  
at Depot**

ITEM	DESCRIPTION	COMMENTS	PART NUMBER	
1	Starter Plate Assembly		SL1	
	8 in Starter Section		SRV22069	
2	Standoff, Front	Qty 2 req	SRV4182-233	
3	Hinge, Male	Qty 2 req	SRV4182-302	
4	Baffle Blanket		SRV4182-205	
5	Baffle	Qty 2 req	SRV4182-113	
6	Baffle Protector		SRV4182-195	
7	Manifold Tube Set	Set of 3	TUBES-4182	
8	Thermocouple	Qty 2 req	SRV4083-147	
	Wire Harness, Thermostat		SRV4182-304	
9	Shield, Sensor	Qty 2 req	SRV4083-212	
10	Brick Retainer, Back		SRV4182-123	
11	Brick Retainer, Side	Qty 2 req	SRV4182-121	
12	Cover Assembly, Control Board		SRV4182-034	
13	Refractory Bottom	Qty 3 req	SRV4182-135	
14	Battery Back Up		SRV4083-177	
15	Control Board Assembly		SRV4182-050	
	Wire Harness, AC		SRV4182-176	
	Wire Harness, JBOX		SRV4182-311	
16	Push Button		SRV4182-134	
17	Knob Knurled Black		SRV4083-743	
18	Control Plate Assembly		SRV4083-035	
19	Fan Control		SRV4083-179	
20	Fan Assembly	Qty 2 req	SRV433-5890	
	Wire Harness, Fan AC		SRV4182-178	
21	Detent Pin, 5/32	Qty 2 req	SRV4083-376	
22	Linear Actuator		SRV4083-130	
23	Air Control Channel Assembly		SRV4182-012	
24	Gasket, Air Control Channel Assembly		SRV4182-189	
25	Outside Air Assembly		SRV4182-039	
26	Unit Collar		SRV4087-314	
	Non-Comb Board Assembly	PIONEER-III-ABK	SRV4182-064	
		PIONEER-III-RBK	SRV4183-064	
	Touch Up Paint	<b>Black</b>	812-0910	

Additional service part numbers on following page.

Beginning Manufacturing Date: Dec 2018  
Ending Manufacturing Date: Active

IMPORTANT: THIS IS DATED INFORMATION. Parts must be ordered from a dealer or distributor. **Hearth and Home Technologies does not sell directly to consumers.** Provide model number and serial number when requesting service parts from your dealer or distributor.



**Stocked  
at Depot**

ITEM	DESCRIPTION	COMMENTS	PART NUMBER	
<div style="display: flex; justify-content: space-around;"> <div style="text-align: center;"> <h3>#27 Door Handle Assembly</h3> </div> <div style="text-align: center;"> <h3>#28 Arch Door Assembly</h3> </div> <div style="text-align: center;"> <h3>#29 Retangle Door Assembly</h3> </div> </div>				
27	Door Handle Assembly		SRV4181-002	
27.1	Handle, Fiber		SRV433-1380	
27.2	Handle, Door		SRV4181-301	
27.3	Washer, 3/8 SAE BK	Pkg of 3	832-0990	
27.4	Door Latch Cam Mill		SRV430-1141	
27.5	Latch Cam Key		SRV430-1151	
27.6	Nut, 3/8 - 16 Prevailing Torque	Pkg of 24	226-0100/24	
28	Arch Door Assembly		SRV4182-030	
28.1	Glass Assembly		SRV4182-031	
	Rope, 1/2 Wire Jacket	10 Ft	7000-811/10	
28.2	Glass Retainer	Qty 2 req	SRV4182-241	
28.3	Glass Retainer	Qty 2 req	SRV4182-270	
	Screw, 8-32 x 3/8 PPH BK	Pkg of 40	225-0500/40	
29	Retangle Door Assembly		SRV4183-030	
29.1	Glass Assembly		SRV4183-031	
	Rope, 1/2 Wire Jacket	10 Ft	7000-811/10	
29.2	Glass Retainer	Qty 4 req	SRV4183-240	
	Screw, 8-32 x 3/8 PPH BK	Pkg of 40	225-0500/40	

Additional service part numbers on following page.

IMPORTANT: THIS IS DATED INFORMATION. Parts must be ordered from a dealer or distributor. **Hearth and Home Technologies does not sell directly to consumers.** Provide model number and serial number when requesting service parts from your dealer or distributor.



**Stocked  
at Depot**

ITEM	DESCRIPTION	COMMENTS	PART NUMBER
------	-------------	----------	-------------

**#30 Brick Assembly**

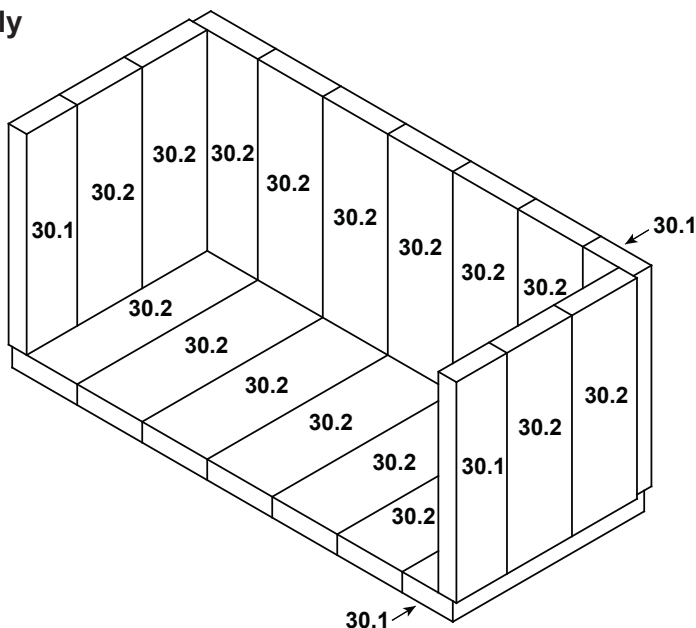

30	Brick Assembly		SRV4182-016
30.1	Brick, 13 1/4 x 3 1/2 x 1 1/4	Qty 4 req	SRV4182-203
30.2	Brick, 13 1/4 x 4 1/2 x 1 1/4	Qty 16 req	SRV4182-301

**Fastener Packs**

	Nut, 3/8 - 16 Prevailing Torque	Pkg of 24	226-0100/24	Y
	Screw, 8-32 x 3/8 PPH BK	Pkg of 40	225-0500/40	Y
	Screw, 8 x 1/2 PPH BK	Pkg of 40	12460/40	Y
	Screw, HWH MS 1/4-20 x 3/4	Pkg of 25	220-0080/25	Y
	Washer, 3/8 SAE BK	Pkg of 3	832-0990	Y

**This page intentionally left blank.**



**B. Contact Information**



Quadra-Fire, a brand of Hearth & Home Technologies  
1915 West Saunders Street  
Mount Pleasant, Iowa 52641

**Please contact your Quadra-Fire dealer with any questions or concerns.**

For the number of your nearest Quadra-Fire dealer, please visit [www.quadrafire.com](http://www.quadrafire.com).

**– NOTES –**

---

---

---

---

---



---

---

---

---

---

<b>CAUTION</b>			
<b>DO NOT DISCARD THIS MANUAL</b>			
	<ul style="list-style-type: none"><li>• Important operating and maintenance instructions included.</li></ul>	<ul style="list-style-type: none"><li>• Read, understand and follow these instructions for safe installation and operation.</li><li>• Leave this manual with party responsible for use and operation.</li></ul>	

This product may be covered by one or more of the following patents: (United States) 5613487, 5647340, 5890485, 5941237, 6006743, 6019099, 6053165, 6145502, 6374822, 6484712, 6601579, 6769426, 6863064, 7077122, 7098269, 7258116, 7470729, 8147240 or other U.S. and foreign patents pending.

2000-945C

## **Appendix B - Alt-125 Letter**



UNITED STATES ENVIRONMENTAL PROTECTION AGENCY  
RESEARCH TRIANGLE PARK, NC 27711

FEB 28 2018

Mr. Justin White  
Hearthstone QHPP, Inc.  
#17 Stafford Ave.  
Morrisville, VT 05661

OFFICE OF  
AIR QUALITY PLANNING  
AND STANDARDS

Dear Mr. White,

I am writing in response to your letter dated January 12, 2018, regarding wood heaters manufactured by Hearthstone QHPP, Inc. (Hearthstone). This response, dated February 28, 2018, supercedes our previous response (dated February 26, 2018) to correct an inaccuracy regarding required changes to ASTM E3053-17.

You are requesting to use an alternative test method, using cord wood, as referenced in section 60.532(c) of 40 CFR part 60, Subpart AAA, Standards of Performance for New Residential Wood Heaters (Subpart AAA) to meet the 2020 cord wood alternative compliance option. The 2020 cord wood alternative compliance option states that each affected wood heater manufactured or sold at retail for use in the United States on or after May 15, 2020, must not discharge into the atmosphere any gases that contain particulate matter in excess of 2.5 g/hr. Compliance must be determined by a cord wood test method approved by the Administrator along with the procedures in 40 CFR 60.534. You have requested approval to use the procedures and specifications found in ASTM Method E3053-17, a cord wood test method titled, "Standard Test Method for Determining Particulate Matter Emissions from Wood Heaters using Cordwood Test Fuel," in conjunction with ASTM E2515-11 and Canadian Standards Administration (CSA) Method CSA-B415.1-10, which are specified in 40 CFR 60.534.

We understand that Hearthstone is also requesting that the alternative method proposed above be approved to apply broadly to all wood heaters manufactured by Hearthstone meeting the requirements of Subpart AAA, from the approval date of this request until such time that Subpart AAA is revised or replaced to require a different cord wood certification method, providing all requirements of section 60.533 of Subpart AAA are met.

With the caveats set forth below, we approve your alternative test method request for certifying wood heaters using ASTM E3053-17 in conjunction with section 60.534 of Subpart AAA to meet the 2020 cord wood compliance option until such time that Subpart AAA is revised or replaced to require a different cord wood certification method. We also approve application of this alternative method to all wood heaters manufactured by Hearthstone meeting the requirements of Subpart AAA.

As required in Subpart AAA, section 60.354(d), you or your approved test laboratory must also measure the first hour of particulate matter emissions for each test run using a separate filter in one of the two parallel sampling trains. These results must be reported separately and also included in the total particulate matter emissions per run. Also, as required by Subpart AAA, section 60.534(e), you must have your approved laboratory measure the efficiency, heat output, and carbon monoxide emissions of the tested wood heater using CSA-B415.1-10. For measurement of particulate matter emission concentrations, ASTM 2515-11 must be used.

The following change to ASTM E3053-17 must be followed:

1. Coal bed conditions prior to loading test fuel. The coal bed shall be a level plane without valleys or ridges for all test runs in the high, low, and medium burn rate categories.

The following changes to ASTM E2515-11 must be followed:

1. The filter temperature must be maintained between 80 and 90 degrees F during testing.
2. Filters must be weighed in pairs to reduce weighing error propagation; see ASTM 2515-11, Section 10.2.1 Analytical Procedure.
3. Sample filters must be Pall TX-40 or equivalent Teflon-coated glass fiber, and of 47 mm, 90 mm, 100 mm, or 110 mm in diameter.
4. Only one point is allowed outside the +/- 10 percent proportionality range per test run.

A copy of this letter must be included in each certification test report where this alternative test method is utilized.

It is reasonable that this alternative test method approval be broadly applicable to all wood heaters subject to the requirements of 40 CFR part 60, Subpart AAA. For this reason, we will post this letter as ALT-125 on our website at <http://www3.epa.gov/ttn/emc/approalt.html> for use by other interested parties. As noted earlier in this letter, this alternative method approval is valid until such time that Subpart AAA is revised or replaced to require a different cord wood certification method, and at such time, this alternative will be reconsidered and possibly withdrawn.

If you have additional questions regarding this approval, please contact Michael Toney of my staff at 919-541-5247 or [toney.mike@epa.gov](mailto:toney.mike@epa.gov).

Sincerely,

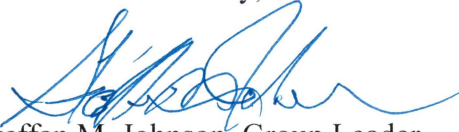

Steffan M. Johnson, Group Leader  
Measurement Technology Group

cc: Amanda Aldridge, EPA/OAQPS/OID  
Adam Baumgart-Getz, EPA/OAQPS/OID  
Rafael Sanchez, EPA/OECA  
Michael Toney, EPA/OAQPS/AQAD